



LA CHAUX-DE-FONDS

SWITZERLAND

10th – 17th AUGUST 1997

PROCEEDINGS OF THE 12th INTERNATIONAL CONGRESS OF SPELEOLOGY



VOLUME 2

6th CONFERENCE ON LIMESTONE HYDROLOGY
AND FISSURED MEDIA

6^e COLLOQUE D'HYDROGÉOLOGIE EN PAYS
CALCAIRE ET EN MILIEU FISSURÉ

The Centre of Hydrogeology, University of Neuchâtel, Switzerland
The Laboratory of Structural and Applied Geology, University of Franche-Comté, Besançon, France
The Swiss Speleological Society

Proceedings of the 12th International Congress of Speleology

Volume 2

Actes du

**6^e Colloque d'Hydrologie
en Pays Calcaire et en Milieu Fissuré**

Proceedings of the
**6th Conference on Limestone
Hydrology and Fissured Media**

La Chaux de Fonds, Switzerland, 10 -17.08.1997

Pierre-Yves Jeannin, *editor*

**Symposium 1: 6th Conference on Limestone
Hydrology and Fissured Media**

Scientific board: Pierre Chauve
Denis Blant
Cyril Delporte
Jacky Mania
Jacques Mudry
Imre Müller
François Zwahlen

Editorial board: Sabine Robert
Gisèle Salomon
Cédric John
Jacques Péguenet

Scientific Committee:

Dr. M. Bakalowicz, Montpellier, France.	Prof. I. Müller, Neuchâtel, Switzerland.
Dr. M. Bouzelboudjen, Neuchâtel, Switzerland.	Prof. J. Mudry, Besançon, France.
Prof. W. Balderer, Zürich, Switzerland.	Prof. A.N. Palmer, Oneonta, USA.
Prof. B. Blavoux, Avignon, France.	Prof. A. Pulido-Bosch, Granada, Spain.
Prof. O. Bonacci, Split, Croatia.	Prof. J. Prestor, Ljubjana, Slovenia.
Prof. L. Bouchaou, Agadir, Morocco.	Dr. J.M. Puig, Avignon, France.
Prof. A. Burger, Neuchâtel, Switzerland.	Prof. M. Razack, Poitiers, France.
Prof. P. Chauve, Besançon, France.	Dr. B. Reichert, Karlsruhe, Germany.
Prof. W. Dreybrodt, Bremen, Germany.	Dr. Y. Rossier, Meyzieu, France.
Prof. C. Drogue, Montpellier, France.	Prof. C. Rousset, Marseille, France.
Prof. J.P. Faillat, Brest-Plouzané, France.	Dr. M. Sauter, Tübingen, Germany.
Prof. D. Ford, Hamilton, Canada.	Prof. P. Smart, Bristol, UK.
Prof. H. Hötzl, Karlsruhe, Germany.	Prof. G. Teutsch, Tübingen, Germany.
Prof. L. Kiraly, Neuchâtel, Switzerland.	Dr. F. Vuataz, Neuchâtel, Switzerland.
Prof. R. Langguth, Aachen, Germany.	Prof. W.B. White, Pennsylvania, USA.
Prof. C. Leibundgut, Freiburg, Germany.	Dr. S. Worthington, Hamilton, Canada.
Dr. A. Mangin, Moulis, France.	Prof. G.M. Zuppi, Torino, Italy.
Prof. J. Mania, Besançon, France.	Prof. F. Zwahlen, Neuchâtel, Switzerland.
Prof. B. Mijatovic, Novi Sad, Yugoslavia.	



International Union of Speleology
Union Internationale de Spéléologie
Internationale Union für Speläologie



Swiss Speleological Society (SSS)
Société Suisse de Spéléologie (SSS)
Schweizerische Gesellschaft für Höhlenforschung (SGH)



United Nations Educational, Scientific and Cultural Organisation
Organisation des Nations Unies pour l'éducation, la science et la culture
United Nations Educational, Scientific and Cultural Organisation



International Association of Hydrogeologists (IAH)
Association Internationale des Hydrogéologues (AIH)



International Association of Hydrological Sciences (IAHS)
Association Internationale des Sciences Hydrologiques (AISH)



Swiss Academy of Sciences (SAS)
Académie Suisse des Sciences Naturelles (ASSN)
Schweizerische Akademie für Naturwissenschaften (SANW)



International Geographic Union
Union Géographique Internationale



International Association of Geomorphologists (I.A.G.)
Association Internationale des Géomorphologues (A.I.G.)

ISBN 2-88374-007-0 (Vol. 2)

ISBN 2-88374-012-7 (Vol. 1-6)

ISSN 0759-7517 (Sciences & Techniques de l'environnement)

Aknowledgements for sponsoring to:

University of Franche-Comté at Besançon
Inter-Unec, Besançon

Publisher: University of Franche-Comté, Sciences & Techniques de l'Environnement

Cover: Titanengang, Hölloch, Switzerland (Photo Ballmann/Widmer)

Sales: Bibliothèque de la Société Suisse de Spéléologie, c/o Bibliothèque de la Ville, Rue du Progrès 33, CH-2300 La Chaux-de-Fonds,
Fax: 021 947 53 78, email: ssslib@vtx.ch

Printed in Switzerland

Papers published from the camera ready copies, prepared by the authors after reviewing by the members of the scientific committee. Despite this, the scientific board wishes to make clear that it shall take no responsibility for any mistakes and omissions, or for the opinions stated by the authors.

SCIENCES & TECHNIQUES DE L'ENVIRONNEMENT, Université de Franche-Comté, mémoire hors-série n°12-1997

Table of Contents

Symposium 1 of the 12th International Congress of Speleology: 6th Conference on Limestone Hydrology and Fissured Media

Session 1: The effects of natural catastrophes and large scale construction on karst aquifers ***Impact d'événements exceptionnels ou de grands travaux sur le comportement des aquifères karstiques***

Bayle Christian	Incidences d'une galerie réalisée à travers un massif avec karst.....	1
Emblanch Christophe, J. Mudry, R. Lastennet & J.M. Puig	Évolution du régime des écoulements karstiques liés à une impulsion pluvieuse exceptionnelle. Exemple de la source de Notre Dame des Anges (Vaucluse, France).....	5
Horat Peter A. Faeh, F. Naef, S. Scherrer & Ch. Zurbrügg	Wie grosse Hochwasser kann die Schüss bringen? Über die Entstehung extremer Hochwasser im verkarsteten Einzugsgebiet der Schüss.....	9
Jeanbourquin Pascal	Eaux souterraines et évaluation des risques liés à l'exploitation des carrières en pays karstiques.....	13
Lastennet Roland, J. Mudry & Ch. Emblanch	La structure du karst: apport par l'étude des écoulements lors de phénomènes pluvieux exceptionnels.....	17
Shenjifang Wanjunwei Y. & X.C.C. Liyanyun	The karstic collapse earthquake induced by water storage of Geheyan reservoir in the Quingjiang River, Hubei, China.....	21

Session 2: Development of measurement techniques in caves and its meaning for the study of karst. ***Évolution des techniques de mesure en grotte et apport pour l'étude du fonctionnement du karst.***

Bakalowicz Michel	Hydrogéologue versus spéléologue, ou de qui relève l'étude et l'exploration des eaux souterraines karstiques?.....	23
Bonacci Ognjen	Role of speleology in karst hydrology and hydrogeology.....	27
Häuselmann Philipp & M. Otz	Wasserfärbung im Gebiet Gemmenalp - Sieben Hengste: Ziele und Resultate.....	31
Hobléa Fabien	Spéléologie, exploitation et protection des eaux souterraines dans les karsts des environs de Chambéry (Savoie - Isère, France).....	35
Le Pennec Robert	Délimitation du bassin versant karstique de la Bienne (Haut-Jura, France) par la géologie et les essais de traçage	39
Martín-Rosales W., M. López-Chicano, A. Pulido-Bosch, & A. Vallejos	Contrôle automatique de plusieurs paramètres dans la Grotte des Merveilles (Aracena, SW de l'Espagne)	43
Schnegg Pierre-André & N. Doerfliger	An inexpensive flow-through field fluorometer	47
Smart Chris C. & L. Zabo	Experimental design, technique and protocol in fluorimetric tracing of ground water	51
Meus Philippe, M. Bakalowicz, W. Käss, B. Barczewsk & G. Schmid	Perspectives offertes par la mesure en continu des traceurs fluorescents dans le karst	55

Session 3: Rock solution kinetics and speleogenesis.
Cinétique de dissolution et spéléogénèse

Borsato Andrea	Dripwater monitoring at Grotta di Ernesto (NE-Italy): a contribution to the understanding of karst hydrology and the kinetics of carbonate dissolution	57
Brouquisse François	Données hydrogéochimiques sur quelques karsts du sud-est asiatique	61
Clemens Torsten, D. Hückinghaus, M. Sauter, R. Liedl & G. Teutsch	Simulation of the evolution of maze caves	65
Destombes Jean-Luc, M. Cordonnier, J.Y. Gadat, & J.J. Delannoy	Periodic and aperiodic forcing of water flow through sodastraw stalactites (Choranche, Vercors, France)	69
Dreybrodt Wolfgang & J. Siemers	Early evolution of karst aquifers in limestone: Models on two-dimensional percolation clusters	75
Eisenlohr Laurent, B. Madry & W. Dreybrodt	Changes in the dissolution kinetics of limestone by intrinsic inhibitors adsorbing to the surface	81
Faillat Jean-Pierre	Abondance et origine des composés carbonés inorganiques des sources karstiques du Languedoc-Roussillon	85
Grasso Domenico A. & P.Y. Jeannin	Approche statistique de l'impact des variations climatiques sur la réponse chimique des sources karstiques	91
Pajón-Morejón Jesús M., A. V. de la Cruz, J. J. Valdés, A. E. García, C. M. Cruz	Geochemical and geomathematical control of the karstic waters composition of the pan de Guajaibón and surroundings, Sierra Del Rosario, Pinar Del Río, Cuba	95
Perrin Jérôme	Géologie et géochimie des eaux dans le réseau du Grand Cor (Valais-Suisse)	99
Sanchez-Moral S., J.C. Cañaveras, E. Sanz-Rubio, M. Hoyos & V. Soler	Hydrogeochemical characterization of Tito Bustillo cave (northern Spain) ...	103
Sauter Martin, R. Liedl, T. Clemens & D.Hückinghaus	Karst aquifer genesis - Modelling approaches and controlling parameters ...	107
Somlette Luc, J.P. Faillat & G. Le Bec	Influence d'intercalations carbonatées en milieu sédimentaire à dominance siliceuse sur le chimisme des eaux (Finistère, France)	111
Vanara Nathalie	Dissolution et spéléogénèse en contexte tectonique actif: Le massif des Arbailles (Pyrénées-Atlantiques, Fr.)	115
Menne Benjamin	Microbiological processes at the cave development and karstification	119
van Beynen P.E., V.A. Toth, D.C. Ford, & H.P. Schwarcz	Seasonal Fluxes of Humic Substances in Cave Drip Waters, Marengo Cave, Southern Indiana	120
Xuewen Zhu	Systematic evolution of subterranean river caves	121
Yuan Daoxian	Characteristics of hydrochemical responses to environmental change in a carbonate rock aquifer	123

Session 4: Hydraulics and mass transport in karst aquifers
Hydraulique et transport de masse
dans les aquifères karstiques

Atteia Olivier	Nature and transport of natural colloids in a karstic aquifer	125
Bundschuh Jochen	Temporal variations of spring water temperatures in relation to the extents of the heat transport modes occurring in the karstified lower Gypsum-Keuper aquifer (Karnian, southern Germany)	129
Doerfliger Nathalie	Results of a study about tracing tests transfer functions variability in karst environment	133
Guglielmi Yves, C. Mangan, J. Mudry & A. Reynaud	Evolution piézométrique et qualitative d'un aquifère carbonaté soumis à un fort pompage de longue durée: exemple du graben de Pinchinade (Mouans-Sartoux, 06)	137
Hauns Michael, F. Hermann & O. Atteia	Application of a computational fluid dynamics model to cave river hydrodynamics	141
Hückinghaus Dirk, R. Liedl & M. Sauter	Characterization of karst aquifers by heat transfer	145
Jeannin Pierre-Yves & J.C. Maréchal	Dispersion and tailing of tracer plumes in a karstic system (Milandre, JU, Switzerland)	149
Liedl Rudolf, S. Renner & M. Sauter	Obtaining information on fracture geometry from heat flow data	153
Maucha Laszlo	Special spring discharge changes in the Aggtelek karst region in Hungary ..	157
Mohrlok Ulf, J. Kienle & G. Teutsch	Parameter identification in double-continuum models applied to karst aquifers	163
Mohrlok Ulf & M. Sauter	Modelling groundwater flow in a karst terrane using discrete and double-continuum approaches - importance of spatial and temporal distribution of recharge	167
Motyka Jacek & A. Zuber	Water levels as response functions for different porous-fissured-karstic systems	171
Pascu Maria, R.D. Gaspar	Application of flow models to the prediction of karst behaviour and pollutant migration in a groundwater system	175
Plagnes Valérie	Le transport de matière dans les aquifères karstiques	179
Smart Chris C.	Modelling of suckwell recharge in carbonate terrain	183
Werner Andreas, H. Hötzl & W. Käb	The interpretation of a High Water Tracer Test in the Danube-Aach-System (western Swabian Alb, Germany)	187
White William B. & E. L. White	Storm pulses, thresholds, and fluid mechanics in the transport of clastic sediments in limestone aquifers	191
Worthington Stephen R.H. & D. C. Ford	Borehole tests for megascale channeling in carbonate aquifers	195
Zechner Eric, D. Genereux, J.D.A. Guardiaro, & J.E. Saiers	Estimation of aquifer parameters in highly permeable limestone (Biscayne Aquifer, Florida).....	199

Session 5: Vulnerability and protection of karst aquifers
Vulnérabilité et protection des aquifères karstiques

Burri Ezio, R. Massoli-Novelli & M. Petitta	Vulnerability of karstic aquifers in Abruzzi (Italy). Two different case-studies: Gran Sasso mountain and Fucino plain	201
Cimino Antonio, R. Abbate, M Macaluso & S. Orecchio	Karst hydrogeology and vulnerability in a coastal sector of Nebrodi Mts. region (Northern Sicily)	205
Doerfliger Nathalie & F. Zwhalen	EPIK, méthode de cartographie de la vulnérabilité des aquifères karstiques pour la délimitation des zones de protection	209
Eiswirth Matthias & H. Hötzl	Contaminant transport from leaky landfills in karst areas	213
Gaspar Radu & I. Paunica	South Dobrogea karst vulnerability by assessment of some geophysical and geochemical parameters	217
Meier Edi, P.Huggenberger, W. Stiefelhagen, I. Müller, & R. Christe	Geophysical methods as a tool for speleological and geotechnical investigation in karst Maira, Plateau de Bure (JU), Switzerland	221
Melloul Abraham J. & S. Wollman	Contamination of carbonate aquifer and evidence of karst effects in Israel ...	225
Montandon Paul-Etienne, S. Gogniat, P. Rognon & J.J. Miserez	Nitrification des eaux rejetées par la STEP de La Chaux-de-Fonds -Suisse lors de leur passage dans le système karstique de la Ronde	229
Motyka Jacek & A. Postawa	Variability of Cl ⁻ ion in water inflows to karst-fissured limestone "Zakrzówek" quarry (Cracow, Poland)	235
Müller Elisabeth, K.P. Seiler & A. Hartmann	Microbiologic activities in open karst aquifers with matrix porosity and consequences for ground water protection in the Franconian Alb, Germany	239
Müller Imre & P. Turberg	"L'image" de la fracturation et de la karstification dans le Jura suisse par prospection magnétique	243

Session 6: Karst hydrogeology
Hydrogéologie du Karst

Abdesselam Malek, H. Lami, J. Mania, J. Mudry, C. Aigoun & P. Chauve	Drainage karstique de la chaîne calcaire du Djurdjura (Grande Kabylie, Algérie). Alimentation et interaction entre composantes évaporitique et carbonatée	247
Andreo B., J. Mudry, F. Carrasco & I. Vadillo	Utilisation des traceurs météoriques (Cl ⁻ , ¹⁸ O) à l'étude des aquifères carbonatés des sierras Blanca et Mijas (Cordillère Bétique, Sud de l'Espagne)	251
Benderev Aleksey & S. Shanov	Karst waters from the region of Bosnek (West Bulgaria): Characteristics and conditions of formation	255
Bodin Jacques & M. Razack	Application du concept de surface élémentaire représentative (S.E.R.) à l'étude comparée entre karstification et tectonique dans le département de La Vienne (France)	259
Collignon Bernard	Etude géophysique et piézométrique d'un karst côtier à Zanzibar	263
Dublyansky Yuri V.	Transition between hydrothermal and cold-water karst	267
Guyot Jean-Loup, L. Melo Filho & A. Auler	Régime hydrologique et flux de matières dissoutes du karst de São Domingos, Goiás, Brésil	271
Herold Th., W. Balderer & P. Jordan	The influence of pre-existing and orogenetic faults to the structures on modern groundwater circulation of two karstic aquifers in the southernmost anticline (Weissenstein) of the folded Jura (Switzerland)	275
Knez Martin	Speleogenesis of phreatic channels in bedding-planes in the frame of karst aquifer (Skocjanske jam Caves, Slovenia)	279
Larocque Marie, A. Mangin, M. Razack & O. Banton	Caractérisation du karst de La Rochefoucauld (Charente, France) à l'aide des analyses corrélatoire et spectrale	283
Lauriol Bernard, I.D. Clark & J. Cinq-Mars	Hydrologie karstique en région de pergélisol: l'exemple du Yukon septentrional, Canada	287
Maréchal Jean-Christophe, M. Looser & A. Dematteis	Caractéristiques hydrogéologiques de deux aquifères calcaires des Préalpes romandes	291
Mijatovic Borivoje F.	Aspect hydraulique de l'écoulement karstique et ses conséquences sur le fonctionnement du système aquifère	295
Mouret Claude & F. Brouquisse	Les écoulements karstiques du polje de Ban Vieng, Laos central	299
Reichert Barbara, H. Hötzl, W. Stichler & P. Trimborn	Hydrodynamic Behavior of a Karst Aquifer (Trnovski gozd Plateau, Slovenia)	303
Rousset Claude	Structure tectonique et typologie karstique: cas des karsts de Vaucluse et de Port-Miou (région Provence - Alpes - côte d'Azur, SE de la France)	307
Sbai Abdelkader	Approche de la structure et du fonctionnement d'un bassin hydrologique en pays calcaire: exemple du bassin du Suran, Jura méridional	311
Smart Chris C.	Hydrogeology of glacial and subglacial karst aquifers: Small River, British Columbia, Canada	315
GorbunovaK.A., N.G. Maximovich & S.M. Blinov	Underground water level regime of the Kungur cave region	319
Lauritzen Stein-Erik	Groundwater recharge in thermoglacial karst springs, South Spitsbergen ...	320
Maucha Laszlo	Studies on the mechanism of tidal phenomena observed in the Aggtelek karst region.....	321

Incidences d'une galerie réalisée à travers un massif avec karst

par Christian BAYLE

Horizons 75 rue M. Berthelot Antélios C F.13858 Aix-en-Provence Cedex 3

Abstract

A tunnel, 3,5 km long, in the Alps of South of France, cross folded and breaked limestone and marl. The karstic water-level, not the same than others aquifers, had repercussions on working sites : stop mining while draining karst, drying up public spring, layout and setting up borehole for drinking water, in a limited area where underground water has high mineralisation.

Résumé

Une galerie de 3,5 km de long, dans les Alpes du Sud, traverse des calcaires et marnes plissés et fracturés. La nappe karstique des calcaires, bien distincte des autres aquifères, a eu des répercussions sur les travaux : arrêt du percement de la galerie pendant le drainage du massif, tarissement d'une source communale, implantation et création de forages pour captage d'eau potable dans un domaine restreint où la minéralisation de l'eau s'est trouvée élevée.

1. Situation géographique

L'ouvrage concerné se trouve dans les Alpes du Sud de la France. La galerie, à l'altitude 630 m NGF, traverse, sur 3,5 km de longueur, le massif de Javanon qui culmine à 870 m NGF.

2. Géologie

Les terrains font partie des chaînes subalpines du domaine autochtone. Deux entités morphologiques distinctes appartiennent aux formations sédimentaires du Secondaire.

2.1. Calcaires du Bajocien et calcschistes du Bathonien

Ils caractérisent le relief du massif de Javanon. Les calcaires ont un débit en plaquettes, séparées par un fin litage marneux. Ils ont été exploités pour la construction, dans une carrière sur le bord occidental du massif.

2.2. Les Terres Noires

Ce sont des marnes schisteuses du Jurassique moyen à supérieur (Bathonien Sup, Oxfordien). Elles se développent largement dans la région, (anticlinorium de Laragne) sur plus de 1000 m d'épaisseur et donnent un relief mou.

2.3. Quaternaire

Différentes formations du **Quaternaire** sont présentes localement :

- placages morainiques de cailloutis et argiles
- dépôt d'argiles varvées fluvio-lacustres,
- éboulis, à la base des versants calcaires de Javanon
- dépôts de tufs.

2.4. Géologie structurale

Au point de vue **structural**, le massif de Javanon forme un dôme anticlinal déversé et chevauchant à l'Est. Le contact, matérialisé par une faille et quelques affleurements de gypse, constitue un accident tectonique régional, de direction N 145°E.

Les déformations subies par les terrains calcaires ont provoqué une fracturation intense. Deux directions de failles, les unes assez proches de celle de l'accident régional, les autres perpendiculaires, délimitent des compartiments. Ceux-ci sont basculés les uns par rapport aux autres autour d'un axe de direction N 145° E.

3. Hydrogéologie

3.1. Calcaires et calcschistes

Ces terrains durs se sont fracturés lors des mouvements tectoniques et par le jeu des failles. Les fissures ont pu être agrandies par dissolution, facilitant l'infiltration et la circulation des eaux météoriques. L'ensemble est perméable en grand et forme un karst. C'est la seule ressource aquifère conséquente du secteur.

Avant 1990, son niveau s'établissait autour de la cote piézométrique 687,50 ; sa principale émergence alimentait la source S.2, captage communal.

3.2. Terres Noires

Les Terres Noires, pratiquement imperméables, ne sont aquifères que dans les zones fissurées ou la partie superficielle altérée. Les failles, d'extension limitée, forment des compartiments relativement indépendants au point de vue aquifère. Ainsi deux piézomètres distants de 200 m ont des niveaux décalés entre eux de 12 à 22 m et des amplitudes de variations comprises entre 5 et 14 m.

Les niveaux actuels sont perchés 25 à 50 m au-dessus de la nappe principale du karst. Cette indépendance a été confirmée lors de pompages en forages.

3.3. Formations quaternaires

De faibles ressources en eau souterraine existent dans les formations plus ou moins perméables, d'extension limitée et peu profondes.

- Les **cailloutis** des placages morainiques forment des réservoirs locaux peu puissants, alimentant de petites sources.
- Les **éboulis**, à la base du versant calcaire, masquent l'émergence de la source communale sortant du karst. L'eau s'écoule à travers les éboulis jusqu'au captage situé en aval.

3.4. Conductivité des eaux

Les mesures de conductivité ont permis de caractériser les différents aquifères, comme indiqué ci-dessous, en microsiemens :

Karst	T. Noires	Proximité du gypse	Compartiment superficiel
470	600 à 900	1000 à 2000	120 à 300

La simple utilisation d'un conductimètre de terrain a donné des résultats appréciables et rapides au cours des travaux.

4. Réalisation des travaux

La coupe prévisionnelle donnait d'aval en amont 1 800 m de Terres Noires, puis du gypse avec la faille majeure, à traverser au plus court, les calcaires et calcschistes karstiques sur 900 m puis à nouveau les Terres Noires en position normale sur environ 800 m.

Une autre galerie, de 2670 m de longueur, réalisée un an avant, au tunnelier dans les Terres Noires, sans difficulté particulière, laissait bien augurer des travaux de Javanon. C'était sans compter sur la tectonique du massif, les terrains fracturés et la faible couverture des premiers 500 m. Le renforcement quasi continu par cintres, revêtu de béton, a modifié le projet initial. Il a fallu augmenter le diamètre du tunnelier pour maintenir les caractéristiques hydrauliques finales de la galerie :

- du pm 0 (aval) au pm 1050 : foration Ø 4,40, finie Ø 3,80 m
- du pm 1050 à 3500 (tête amont) foration Ø 4,90, finie Ø 4,10 m

4.1. Venues d'eau

Plusieurs venues d'eau se sont produites au cours de l'avancement du tunnelier. Les débits sont restés peu élevés dans les Terres Noires : 1 à 5 l/s. La conductivité des eaux de 600 à 800 μS , a dépassé 1000 à proximité de la zone faillée avec gypse.

Lors du percement des calcaires et calcschistes, une forte venue d'eau de 150 l/s au pm 2120, a bloqué le chantier pendant quatre mois. La conductivité 460 μS a confirmé l'identité des eaux avec celles de la source du captage communal.

Les travaux au tunnelier n'ont pu reprendre qu'après réduction de la charge, de l'ordre de 55 m, par drainage et vidange du karst jusqu'au niveau de la galerie.

Dans le dernier tronçon de la galerie à réaliser, à nouveau dans les Terres Noires, un niveau piézométrique indiquait aussi une charge importante.

Le chef de chantier a pu être rassuré : la structure compartimentée et la mauvaise perméabilité des marnes schisteuses n'ont provoqué que de faibles venues d'eau.

4.2. Rétablissement de l'alimentation en eau potable

Le tarissement de la source communale a conduit à utiliser un puits qui existait en nappe alluviale. L'alimentation du réseau intercommunal par refolement, et non plus gravitaire, a posé quelques difficultés.

Afin de maintenir une diversification des ressources en eau potable et rétablir une distribution gravitaire, il a été décidé de réaliser un nouveau captage par forage. Les recherches se sont orientées sur la seule ressource satisfaisante en dehors de la nappe alluviale : l'aquifère karstique du massif de Javanon.

4.3. Les contraintes du nouveau captage

L'implantation du forage de captage était conditionnée par la nécessité d'atteindre le niveau aquifère, rabattu par la galerie, et situé dans les calcaires fissurés.

Le pendage accentué des couches de calcschistes sus-jacents nécessitait un compromis entre la profondeur et la couche productive à atteindre d'une part, l'implantation dans un relief accidenté d'autre part.

D'autres contraintes s'ajoutaient :

- s'éloigner de la faille avec gypse et d'un forage existant dans les Terres Noires (protection et influence éventuelle),
- s'approcher des anciennes émergences tarées pour retrouver des terrains bien fissurés et pour se raccorder à l'adduction existante.

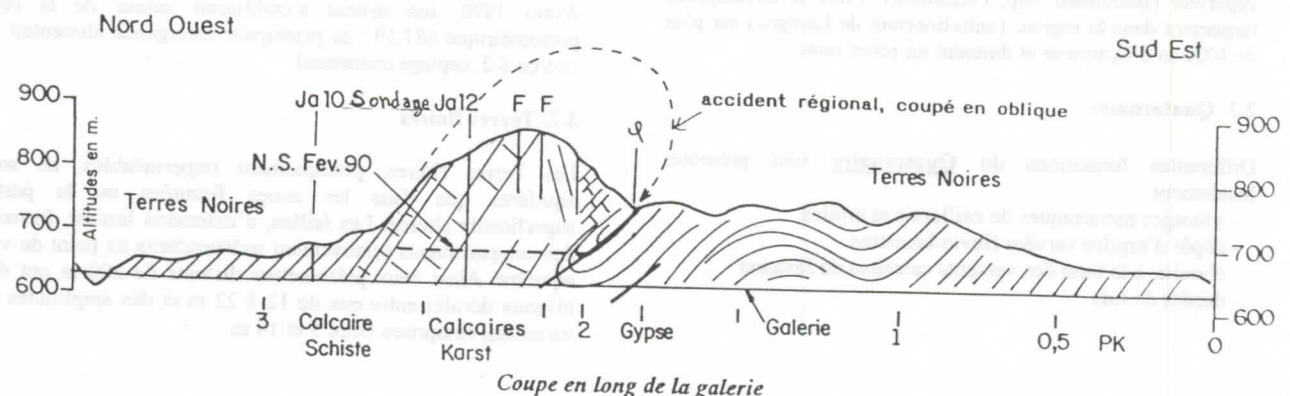

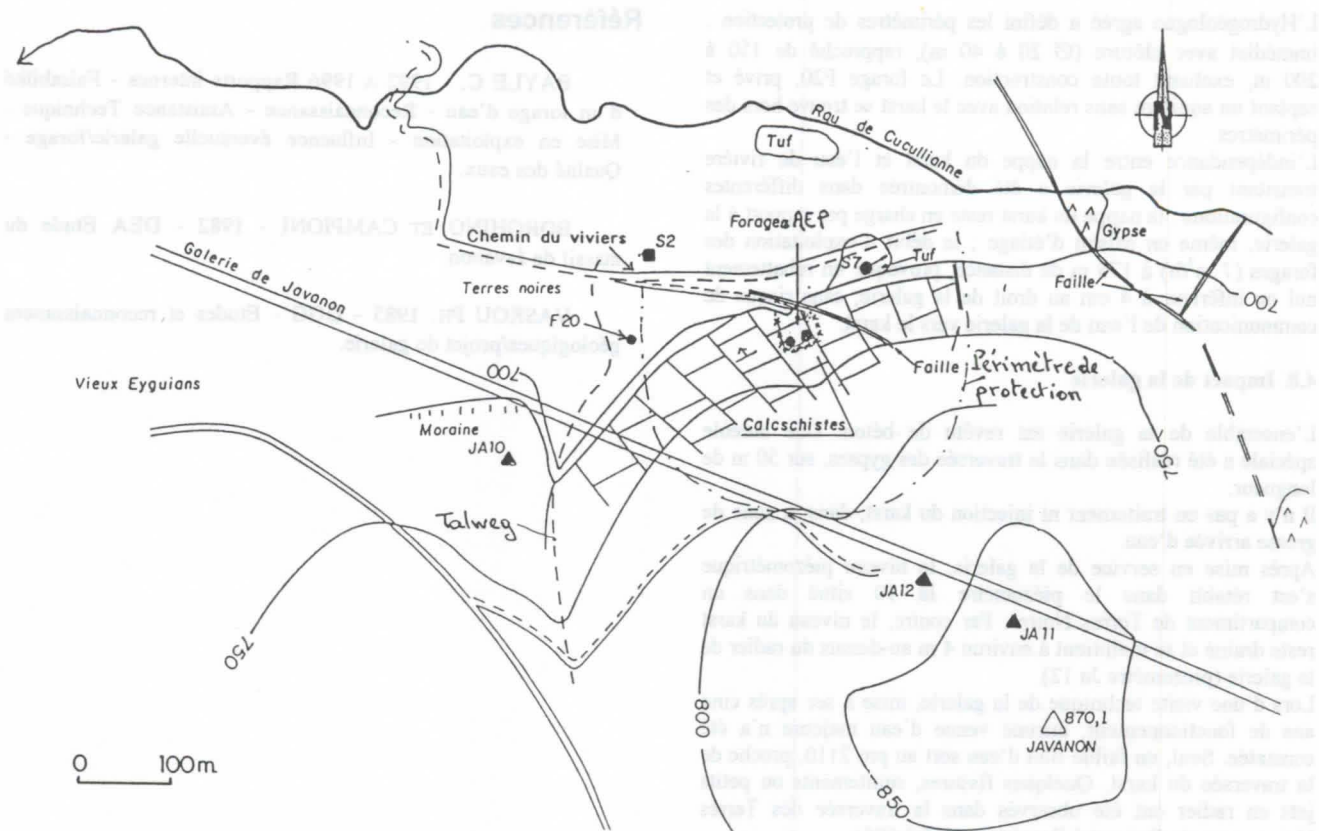

Plan de situation des points d'eau

Deux forages, tubés Ø 168/4 mm, ont été réalisés et équipés, de préférence à un seul ouvrage de gros diamètre, pour disposer de deux pompes (sécurité).

4.4. Réalisation et résultats des forages

Une plate-forme a été taillée à la cote 702 m NGF, dans les calcschistes à la base du versant Nord de Javanon, à forte pente. Les forages y ont été implantés à 24 m de distance l'un de l'autre. Les premières venues d'eau sont apparues entre 80 et 85 m de profondeur. Les débits importants, de 20 à 25 m³/h se sont produits à plus de 100 m lorsque les terrains sont passés progressivement à des calcaires en plaquettes. Les débits obtenus sont trois fois plus élevés que le débit de l'ancienne source. La foration a été arrêtée à 150 m dans F1 et 140 m dans F2 à cause d'un terrain broyé difficile. Toutefois, les caractéristiques de F2 sont meilleures. Pour un rabattement de 1 m, le débit est de 20 m³/h contre 5 dans F1. Les tubages sont crépinés sur 40 m au-dessus du fond. Le niveau d'eau s'est stabilisé autour de 68 m de profondeur soit la cote 634 m NGF, tandis que le radier de la galerie se trouve à 630 m NGF.

4.5. Qualité de l'eau

On a vu la similitude de la conductivité des eaux drainées par la galerie au pm 2120 et de l'ancien captage communal S2 (460 µσ). Par contre dans les forages, bien que positionnés à mi distance entre les deux points ci-dessus, les eaux se sont révélées plus chargées.

Parmi les composants les plus significatifs, on a : conductivité 700 µσ, dureté 45°, SO₄ : 180 mg/l, Fe : 0,95 mg/l, oxygène dissous : 1,45. Cette eau fortement minéralisée, séléniteuse proche de la limite de potabilité, et avec une teneur en fer supérieure à la norme, nécessite un traitement de déferrisation pour la distribution publique. Cependant au point de vue bactériologique, l'eau est exempte de germe.

4.6. Hypothèse explicative

La minéralisation élevée de l'eau des forages peut s'expliquer par une faible teneur en oxygène dissous. La zone captée dans le karst se trouve confinée sous un recouvrement de marnes et de schistes. Le karst est plus « ouvert » dans la partie traversée par la galerie ; il n'y eut aucun dépôt de fer ni trace de rouille à l'exutoire, pendant toute la période de plus de six mois de vidange et de drainage du karst. De même l'ancienne source communale S2 donnait une eau potable sans fer. En effet, la circulation de l'eau à travers des éboulis, depuis le griffon jusqu'au captage, permettait aération et précipitation de la surcharge minérale, comme en attestent localement plusieurs dépôts de tuf.

4.7. Protection

Les forages sont cimentés sur les dix mètres supérieurs et crépinés entre 100 et 150 m de profondeur. L'eau des forages, destinée à l'alimentation humaine, sera traitée pour abaisser la teneur en fer.

L'Hydrogéologue agréé a défini les périmètres de protection : immédiat avec clôture (\varnothing 20 à 40 m), rapproché de 150 à 200 m, excluant toute construction. Le forage F20, privé et captant un aquifère sans relation avec le karst se trouve hors des périmètres.

L'indépendance entre la nappe du karst et l'eau de rivière transitant par la galerie a été démontrée dans différentes configurations : la nappe du karst reste en charge par rapport à la galerie, même en saison d'étiage ; le débit d'exploitation des forages ($7 \text{ m}^3/\text{h}$) à 175 m de distance, provoque un rabattement nul ou inférieur à 4 cm au droit de la galerie, sans risque de communication de l'eau de la galerie vers le karst.

4.8. Impact de la galerie

L'ensemble de la galerie est revêtu de béton. Une auréole spéciale a été réalisée dans la traversée des gypses, sur 50 m de longueur.

Il n'y a pas eu traitement ni injection du karst, dans la zone de grosse arrivée d'eau.

Après mise en service de la galerie, le niveau piézométrique s'est rétabli dans le piézomètre Ja 10 situé dans un compartiment de Terres Noires. Par contre, le niveau du karst reste drainé et se maintient à environ 4 m au-dessus du radier de la galerie (piézomètre Ja 12).

Lors d'une visite technique de la galerie, mise à sec après cinq ans de fonctionnement, aucune venue d'eau majeure n'a été constatée. Seul, un faible filet d'eau sort au pm 2110, proche de la traversée du karst. Quelques fissures, suintements ou petits jets en radier ont été observés dans la traversée des Terres Noires, essentiellement à l'aval (pm. 665 à 685).

Les débits drainés par la galerie, sur 3,5 km, totalisent 10 l/s. Cette valeur est du même ordre de grandeur que les débits évacués lors du percement - sans compter les eaux venant du karst - Celles-ci, à la fin de la période de drainage, donnaient à elles seules 12 à 15 l/s.

Le bilan de l'exutoire de la galerie se trouve inférieur de moitié à la valeur réelle attendue. Le niveau du karst reste rabattu sans qu'un débit manifeste apparaisse ni à l'intérieur ni autour de la galerie. D'ailleurs, l'auréole de cimentation autour du gypse bloque tout écoulement éventuel. Cependant aucune remontée de la nappe du karst n'a été observée depuis la mise en service de la galerie.

Le percement d'une galerie à travers un massif comportant des calcaires fracturés a eu plusieurs impacts :

- impacts directs :

- 1. sur la nappe karstique qui a été rabattue et drainée,
 - . arrêt et retard des travaux de percement,
 - . tarissement d'une source communale nécessitant la création d'un captage par forage ;

- impacts indirects :

- 1. sur les petits aquifères locaux, notamment dans les placages morainiques, les éboulis ou les couches d'altération superficielles. Les ressources en eaux souterraines, en partie drainées par les fissures du massif sous-jacent, ont diminué.

Références

BAYLE C. - 1992 A 1996 Rapports internes - Faisabilité d'un forage d'eau - Reconnaissance - Assistance Technique - Mise en exploitation - Influence éventuelle galerie/forage - Qualité des eaux.

BORGHINO ET CAMPIONI - 1982 - DEA Etude du massif de Javanon

VASKOU PH. 1985 - DGG - Etudes et reconnaissances géologiques/projet de galerie.

Evolution du régime des écoulements karstiques liés à une impulsion pluvieuse exceptionnelle. Exemple de la source de Notre Dame des Anges (Vaucluse, France)

par Christophe Emblanch*, Jacques Mudry**, Roland Lastennet*** & Jean-Michel Puig*

*Laboratoire d'hydrogéologie, Faculté des sciences, 33 rue louis Pasteur, 84000 Avignon.

**Laboratoire de Géologie Structurale et Appliquée, Faculté des Sciences, 1 place Leclerc, 25000 Besançon.

*** CDGA Bordeaux I, Bâtiment Géologie, Avenue des Facultés, 33405 Talence.

Abstract

Karst systems are generally considered as a stable systems. However they can be widely modified during exceptional rainfall. These modifications can concern the shape of the outlet which deeply transform the hydrodynamical behavior.

We studied the consequence of an exceptional rainfall (>300 mm in 4 h). We observed immediate morphologic variation. The study of the recession coefficient shows an hydrodynamic evolution increasing stormflow, karstification possibilities and decreasing the reserve.

Résumé

Généralement les systèmes karstiques apparaissent comme relativement stables à l'échelle de temps humaine. Les modifications qui tendent à atteindre l'équilibre sont lentes. Cependant à la faveur d'événements pluvieux exceptionnels, il peut se produire des évolutions brutales. Ces transformations rapides peuvent atteindre la forme de l'exutoire, mais aussi transformer profondément l'hydrodynamique du système.

Dans le cadre de ce travail, nous avons étudié les conséquences d'un épisode pluvieux exceptionnel en intensité (plus de 400 mm en 4 h), nous avons constaté des variations morphologiques importantes immédiates, mais aussi des évolutions rapides (quelques années) induites par ce phénomène. Par l'intermédiaire de l'étude des courbes de récessions, nous avons montré une évolution hydrodynamique du système qui a conduit à une augmentation des débits de crues, de nouvelles possibilités de karstification et une diminution des réserves.

1. Introduction

Les précipitations à caractère exceptionnel marquent la mémoire collective par leurs manifestations immédiates telles que les inondations. Dans les aquifères karstiques, ces événements provoquent également des modifications qui, même si elles ne sont pas toujours aussi spectaculaires, vont affecter le système en profondeur. Ainsi dans la partie septentrionale de la Provence, l'orage du 22/09/1992 (plus de 300 mm en 4 heures) reste dans toutes les mémoires comme la catastrophe de Vaison-la-Romaine. Pour les hydrogéologues, cet orage aura aussi permis de mettre en évidence des évolutions brutales d'aquifères karstiques, évolution physique spectaculaire mais aussi hydrodynamique.

Après avoir commenté les différentes modifications de l'exutoire et leur relations possibles avec l'événement exceptionnel, nous ferons une étude hydrodynamique du système au travers des coefficients de tarissement.

2. Présentation du site d'étude

Le système de Notre-Dame des Anges, que nous avons suivi dans le cadre de cette étude, est localisé dans le S-E de la France, à la limite NE du Mont Ventoux (figure 1). Son fonctionnement semble se faire essentiellement par effet piston avec un rôle important de la zone non saturée (LASTENNET, 1994).

Outre la réaction de l'exutoire principal et des différents griffons qui se sont activés lors de l'orage du 22/09/1992, Lastennet a constaté une évolution dans le comportement hydrodynamique de ce système entre les crues qui précèdent et celles qui suivent cet orage (LASTENNET & MUDRY, 1995).

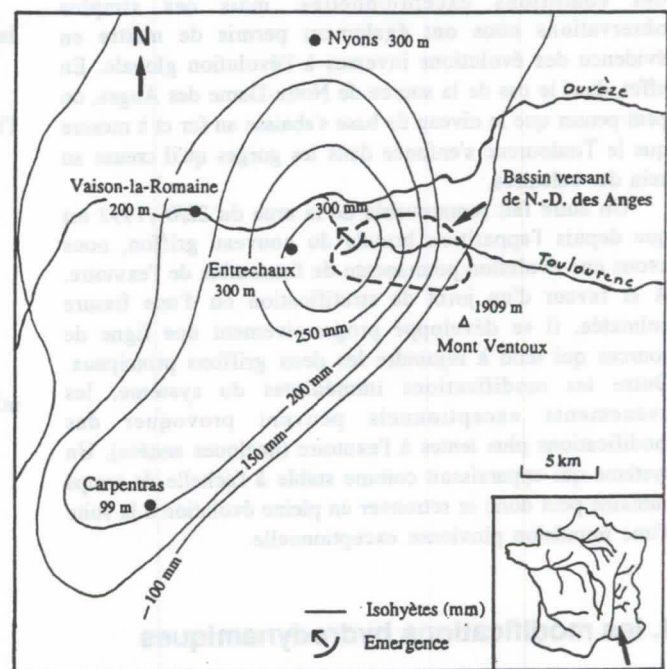

Fig. 1 : Isohyètes de l'orage du 22/09/1992 (d'après CIRAME modifié) localisation du bassin versant de Notre-Dame des Anges (LASTENNET et MUDRY, 1995).

Il est à noter qu'à l'occasion de la crue qui a suivi l'orage du 22/09/1992, de profondes modifications sont apparues à l'exutoire. Au griffon principal, par lequel s'écoulait plus de 80% de l'eau, est venu s'ajouter un second griffon qui a immédiatement drainé une partie conséquente des écoulements. Il faut également tenir compte du fait que lors de cette crue, un exutoire considéré alors comme inactif (grotte situé 5 m au dessus de l'exutoire et qui permet un accès à la zone noyée), a fonctionné pendant deux jours avec un débit de pointe estimé à 15 m³/s et des eaux à forte turbidité (qui sont la preuve d'un décolmatage important).

3. Les modifications physiques

Les évolutions les plus directement observables sont les modifications physiques à l'exutoire. Le nouveau griffon qui est apparu à quelques mètres du précédent draine quatre ans après plus de la moitié du débit. La forme de ce nouvel exutoire (cylindrique et de plusieurs centimètres) montre qu'il s'agit de la réactivation d'un ancien conduit qui avait certainement été colmaté par le Toulourenc (rivière dont le lit borde les exutoires de la source de NDA). Ce nouveau griffon pérenne est situé plus bas que l'ancien. Sachant qu'avant le 22/09/1992 il était colmaté (aucun écoulement n'existait alors à cet endroit), on peut en déduire qu'à un moment donné le niveau de base était remonté (lors du colmatage de ce griffon). L'évolution des aquifères karstiques peut donc se faire de façon brutale en rapport avec des conditions exceptionnelles, mais ces simples observations nous ont également permis de mettre en évidence des évolutions inverses à l'évolution globale. En effet, dans le cas de la source de Notre-Dame des Anges, on peut penser que le niveau de base s'abaisse au fur et à mesure que le Toulourenc s'enfonce dans les gorges qu'il creuse au sein des calcaires.

Un autre fait remarquable de la crue du 22/09/1992 est que depuis l'apparition brutale du nouveau griffon, nous avons une évolution permanente de l'ensemble de l'exutoire. À la faveur d'un joint de stratification ou d'une fissure colmatée, il se développe progressivement une ligne de sources qui tend à rejoindre les deux griffons principaux. Outre les modifications immédiates du système, les événements exceptionnels peuvent provoquer des modifications plus lentes à l'exutoire (quelques années). Un système qui apparaissait comme stable à l'échelle de temps humaine peut donc se retrouver en pleine évolution à la suite d'une impulsion pluvieuse exceptionnelle.

4. les modifications hydrodynamiques

Toutes ces modifications visibles à l'exutoire, et notamment l'abaissement du niveau de base peuvent avoir modifié l'hydrodynamique du système. L'étude de R. LASTENNET (1994) faisait apparaître des évolutions sensibles du coefficient de tarissement dans les crues suivant immédiatement celle du 22/09/1992. S'agissait-il d'un phénomène momentané, d'une évolution du système ou d'un artefact lié au fait qu'il ne maîtrisait plus l'ensemble des débits? Les données d'un suivi réalisé en 1995-1996 vont nous permettre de répondre à ces questions.

L'étude des coefficients de tarissement passe par une bonne connaissance des débits. Avant 1992, la quasi totalité de ceux ci s'écoulaient au travers d'un déversoir triangulaire, il était donc facile d'établir une courbe de tarage. Pour l'étude de 1995-1996, le système est plus complexe puisqu'il comporte deux exutoires. Pour le griffon qui s'écoule à travers le déversoir il n'y a pas eu de problème, pour le second par contre aucun équipement n'était disponible. Afin d'établir une courbe de tarage complète, nous avons profité d'une forte crue pour procéder à de nombreux jaugeages simultanés sur les deux griffons. On a ainsi pu établir une relation entre les deux griffons (figure 2). Connaissant les débits à l'exutoire équipé du seuil, nous avons ensuite déduit celui du total deux exutoires. Par sécurité, nous avons régulièrement procédé à des jaugeages de vérification qui, bien que le système apparaisse comme en pleine évolution, n'ont montré aucune modification sensible de la relation établie entre les deux griffons.

Définition des coefficients et des volumes de tarissement

Le coefficient de tarissement α :

les courbes de tarissement peuvent être décrites par une fonction exponentielle de la forme (MAILLET, 1905) :

$$Q(t) = Q_0 e^{-\alpha t}$$

avec $Q(t)$ débit à l'exutoire au temps t ,

Q_0 débit de tarissement à un instant t_0

α le coefficient de tarissement (pente de la droite issue de la relation $\ln Q - \text{temps}$).

Le volume de tarissement est défini à partir de l'intégration de la formule de Maillet, on obtient :

$$V = c \int_{t_0}^{\infty} Q_0 e^{-\alpha t} dt = \frac{Q_0}{\alpha} c$$

avec c facteur de correction de l'unité de temps, si Q en m³/s et t en jours, alors $c = 86400$.

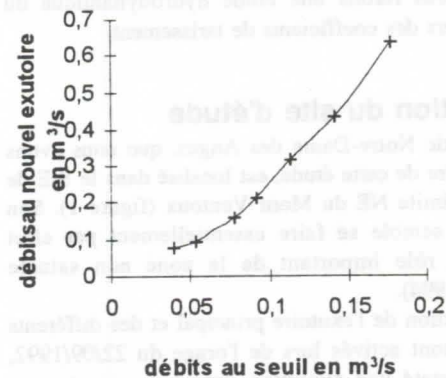

Fig. 2 : Relation entre les deux exutoires de Notre-Dame des Anges

Le terme de volume de tarissement (CASTANY & MARGAT, 1977) est défini comme le volume d'eau déplacé dans l'aquifère (réserve noyée, drains, eau de la zone non saturée), susceptible d'être renouvelé, et s'écoulant à l'exutoire en suivant une fonction exponentielle de type Maillet (ROQUES, 1972, MANGIN, 1975, BAKALOWICZ & MANGIN, 1980, SOULIOS, 1991, BONACCI & ZIVALJEVIC, 1993). Le volume calculé dépend du débit initial Q_0 choisi à un instant t_0 . Il est préférable de prendre ce temps t_0 au début du tarissement et non au moment du pic de crue, les écoulements de la réserve pendant les crues ne suivant pas une relation exponentielle de type tarissement (BLAVOUX & MUDRY, 1983, DREISS, 1989, HARUM & al., 1992).

Détermination des coefficient de tarissement et des volumes dynamiques :

Pour la période 1991-1992, nous utiliserons les résultats de R. LASTENNET (1994). La figure 3 montre clairement l'évolution qu'il a pu observer sur les coefficients de tarissement entre les crues précédant et suivant la crue du 22/09/1992.

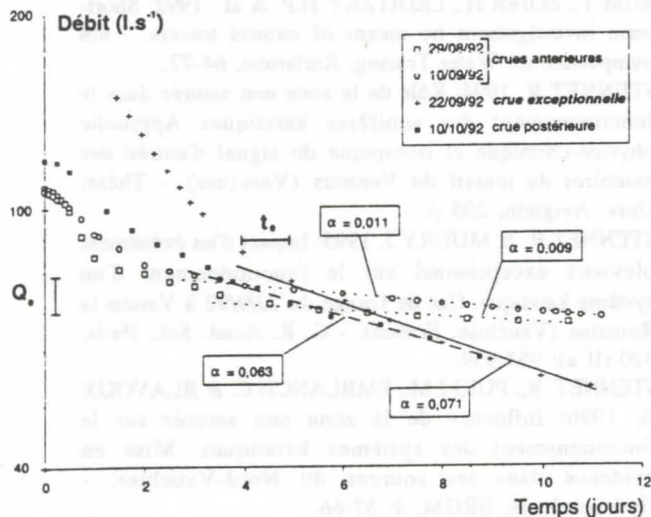

Fig. 3 : Courbes de récession ($Q=f(t)$) faisant suite à quatre crues de l'automne 1992 à Notre-Dame des Anges, échelle semi logarithmique (d'après LASTENNET & al., 1995).

Comme nous l'avons dit précédemment, après le 22/09/1992, il ne maîtrisait pas tous les débits, mais la relation quasi-linéaire entre les deux griffons que nous avons obtenue en 1995 laisse supposer que même avec des débits partiellement maîtrisés, la pente de tarissement calculée est la bonne, par contre, on ne tiendra pas compte du Q_0 et du volume de tarissement calculés dans ces conditions.

Avec la chronique enregistrée en 1995-1996, nous allons vérifier si ces modifications hydrodynamiques apparues après la crue du 22/09/1992 étaient temporaires ou durables. Pour cela nous avons choisi trois tarissements sur la chronique que nous possédons (figure 4). Notre choix s'est porté sur les tarissements les moins perturbés par des précipitations lors de la décrue.

Nous allons comparer des crues d'automne (1992) à des crues d'automne et de printemps (1995-1996). La crue du 28/11/1995 est la première crue d'automne et les paramètres

obtenus sont identiques à ceux du printemps 1996. Nous pouvons donc comparer les deux chroniques sans tenir compte de leur différence de position par rapport au cycle hydrologique.

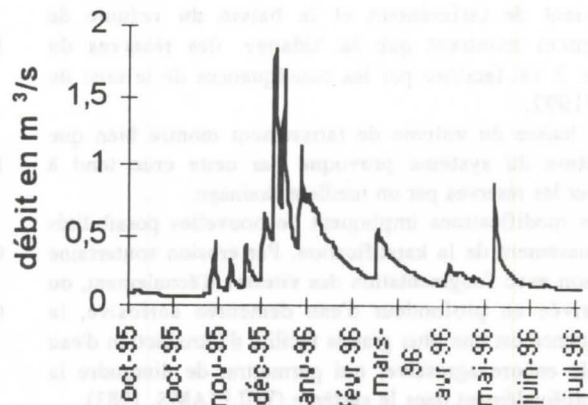

Fig. 4 : Courbes des débits de l'ensemble des exutoires de Notre-Dame des Anges pour la période d'octobre 1995 à août 1996.

5. Discussion

L'ensemble des résultats est récapitulé dans le tableau 1.

On constate immédiatement que le débit de tarissement Q_0 a considérablement augmenté entre les deux périodes de mesure. Cette variation peut être attribuée à la baisse du niveau de base liée à l'apparition du nouveau griffon, ou au fait que la période 1995-1996 se trouve dans une succession d'années humides alors qu'en 1991-1992 on avait des années sèches.

crues	débit max (l/s)	débit Q_0 à t_0 en l/s	α	Volume de tarissement (m^3)
22/8/92	107.7	69.4	0.0099	$0.606 \cdot 10^6$
10/9/92	106.2	73.2	0.0108	$0.586 \cdot 10^6$
22/9/92			0.0713	
10/10/92			0.063	
28/11/95	403	121	0.04	$0.261 \cdot 10^6$
24/1/96	900	165	0.03	$0.475 \cdot 10^6$
3/6/96	1100	151	0.03	$0.434 \cdot 10^6$

Tab.1 : Paramètres tirés des courbes de tarissement des crues à Notre-Dame des Anges avant et après la crue de Vaison la Romaine.

Après une période de crue, le système pourra soutenir le débit d'étiage à l'aide de ses réserves. Le coefficient de tarissement doit donc diminuer. C'est exactement l'inverse qui se produit entre les valeurs précédant l'orage du 22/09/1992 et celle de 1995-1996. On peut donc bien attribuer les variations hydrodynamiques à l'exutoire aux variations physiques observées sur celui-ci. Il ne peut pas s'agir d'un phénomène lié aux conditions hydrologiques. De plus, on observe un doublement du débit de tarissement Q_0 qui, lui aussi, ne peut être attribué qu'à une modification hydrodynamique permanente du système.

Dans la même période, le volume de tarissement a plutôt tendance à diminuer. La baisse brutale du niveau de base provoquée par l'apparition du nouveau griffon a modifié les conditions d'écoulement à l'exutoire. L'augmentation du coefficient de tarissement et la baisse du volume de tarissement montrent que la vidange des réserves du système a été facilitée par les conséquences de la crue du 22/09/1992.

La baisse du volume de tarissement montre bien que l'évolution du système provoqué par cette crue tend à diminuer les réserves par un meilleur drainage.

Ces modifications impliquent de nouvelles possibilités d'accroissement de la karstification. Par érosion souterraine en liaison avec l'augmentation des vitesses d'écoulement, ou par arrivée en profondeur d'eau demeurée corrosive, la conséquence est une plus grande facilité d'introduction d'eau nouvelle encore agressive, qui permettra, de dissoudre la roche profondément dans le système (WILLIAMS, 1983).

Conclusion

Au travers de cette étude de la modification physique et hydrodynamique d'un système karstique faisant suite à un épisode pluvieux exceptionnel, nous avons pu mettre en évidence la relative fragilité des caractéristiques de ce type d'aquifère. Il ne s'agit pas d'une sensibilité à telle ou telle pollution, mais de celle à l'équilibre hydrodynamique. Un système qui paraissait stable à l'échelle de temps humaine s'est vu totalement transformé du jour au lendemain. L'apparition d'un nouveau griffon qui abaisse le niveau de base et un fort décolmatage ont radicalement modifié l'exutoire. Ensuite cette évolution physique à l'exutoire a provoqué une amélioration du drainage de l'aquifère et a ainsi multiplié les débits de crues par 5 ou 10, il s'ensuit une diminution sensible des réserves. On imagine aisément les problèmes qui se poseraient si une telle évolution se produisait sur un aquifère capté et surexploité en étiage.

Enfin nous avons pu mettre en évidence que non seulement l'évolution des systèmes karstiques peut être brutale, mais qu'elle peut également être inversée. Le nouveau griffon qui est apparu est en fait un ancien conduit qui avait été obstrué par les dépôts alluviaux du Toulourenc. On peut d'ailleurs imaginer que des conditions climatiques particulières (phase érosive sur le bassin versant marneux du Toulourenc par exemple) amènent à un nouveau comblement de ce griffon.

Références

- BAKALOWICZ M. & MANGIN A. 1980: L'aquifère karstique. Sa définition, ses caractéristiques et son identification. - Mém. hors. série. Soc. Géol. France.11, 71-79.
- BLAVOUX B. & MUDRY J. 1983: Séparation des composantes de l'écoulement d'un exutoire karstique à l'aide des méthodes physico-chimiques. - Hydrogéol. Géol. Ing., BRGM, Orléans, 4 : 269-278.
- BONACCI O. & ZIVALJEVIC R. 1993: Hydrological explanation of the flow in karst: example of the Crnojevica spring: J. Hydrol., 146: 405-419.
- CASTANY G & MARGAT J. 1977: Dictionnaire français d'hydrologie. - BRGM, 249p.
- CIRAME (Centre d'information Regional Agro-Météorologique et Economique de Vaucluse). 1992: Bulletin climatique et agroclimatique de Vaucluse, 73, sept. 92, 27p.
- DREISS S. J. 1989: Regional scale transport in a karst aquifer. 1. Component separation of springflow hydrographs. - Water Resources Research, 25(1): 7-125.
- HARUM T., ZOJER H., LEDITZKY H.P. & al. 1992: Short-term investigations by means of naturel tracers. - 6th symposium on Water Tracing, Karlsruhe, 64-77.
- LASTENNET R. 1994: Rôle de la zone non saturée dans le fonctionnement des aquifères karstiques Approche physico-chimique et isotopique du signal d'entrée des exutoires du massif du Ventoux (Vaucluse). - Thèse, Univ. Avignon, 205 p.
- LASTENNET R. & MUDRY J. 1995: Impact d'un événement pluvieux exceptionnel sur le fonctionnement d'un système karstique. Cas de l'orage du 22/9/92 à Vaison la Romaine (Vaucluse, France). - C. R. Acad. Sci., Paris, 320 (II a): 953-959.
- LASTENNET R., PUIG J.M., EMBLANCH C. & BLAVOUX B. 1996: Influence de la zone non saturée sur le fonctionnement des systèmes karstiques. Mise en évidence dans les sources du Nord-Vaucluse. - Hydrogéologie, BRGM, 4: 57-66.
- MAILLET E. 1905: Essais d'hydraulique souterraine et fluviale. - Herman, Paris, 218 p.
- MANGIN A. 1975: Contribution à l'étude hydrodynamique des aquifères karstiques. Thèse Sc. Univ. Dijon, 258 p. - Ann. Spéléol., 29: 283-332, 495-601; 30: 21-124.
- ROQUES H. 1972: Sur une nouvelle méthode graphique d'étude des eaux naturelles. - Ann. Spéléol., 27: 79-92.
- SOULIOS G. 1991: Contribution à l'étude des courbes de récession des sources karstiques : exemples du pays Hellénique. - J. Hydrol. 124: 29-42.
- WILLIAMS P. W. 1983: The role of the subcutaneous zone in karst hydrology. In BACK W. et LAMOREAUX P. E., eds. - V. T. Stringfield Symposium. Processes in Karst Hydrology. - J. Hydrol., 61: 45-67.

Wie grosse Hochwasser kann die Schüss bringen? Über die Entstehung extremer Hochwasser im verkarsteten Einzugsgebiet der Schüss

P.Horat, A. Faeh, F.Naef, S.Scherrer, Ch. Zurbrügg

Versuchsanstalt für Wasserbau, Hydrologie und Glaziologie (VAW), ETH Zentrum, CH-8092 Zürich

Abstract

Large parts of the Schüss catchment are dominated by karst. In the wake of the 1990 and 1991 floods, during which the capacity of the Schüss channel in Biel was almost exceeded, the size of extreme floods for this catchment had to be estimated. By means of different methods (investigation of historical floods, analysis of hydrographs, integration of geological and pedological information, experiments with artificial rain, rainfall-runoff-modelling) the catchment reaction was determined. The karstic parts of the catchment react slowly to rainfall and are able to retain large amounts of water. Only prolonged rainfall events in combination with snow melt and frozen soil conditions are therefore able to generate large floods. An unfavourable combination of these factors could lead to floods significantly larger than any of those observed during the last 130 years.

Zusammenfassung

Grosse Teile des Einzugsgebietes der Schüss sind verkarstet. Nach zwei Hochwassern 1990 und 1991, bei denen die Kapazität des Schüsskanals in Biel nahezu erschöpft war, stellte sich die Frage nach der Grösse von Extremhochwassern. Aus verschiedenen Teiluntersuchungen (historische Hochwasser, Ganglinienanalyse, Umsetzung geologischer und pedologischer Grundlagen, Beregnungsversuche, Niederschlag-Abflussmodellierung) ergab sich ein Bild von den massgebenden Abflussprozessen bei Hochwasser. Die von Karst dominierten Teile des Einzugsgebietes reagieren langsam auf Niederschläge und vermögen grosse Wassermengen zu speichern. Daher werden grosse Hochwasser nur von langandauernden, ergiebigen Niederschlagsereignissen in Verbindung mit Schneeschmelze und Bodenfrost erzeugt. Bei einer ungünstigen Kombination dieser Faktoren sind wesentlich höhere Abflüsse möglich, als in den letzten 130 Jahren beobachtet wurden.

1. Einleitung

Durch die Stadt Biel am Fusse des Juras fliesst die kanalisierte Schüss. Grosse Teile des Einzugsgebietes sind verkarstet. 1990 und 1991 traten kurz hintereinander zwei Hochwasser auf, die zu Überschwemmungen im Einzugsgebiet führten. Bei beiden Hochwassern wurde die Kapazität des Schüsskanals in Biel voll ausgelastet und zum Teil erschöpft. Ein nur geringfügig höherer Abfluss hätte in Biel zu Überschwemmungen mit grossen Schadensfolgen geführt. Um entscheiden zu können, ob ein Ausbau des Kanals sinnvoll ist, musste abgeklärt werden, ob die beobachteten Hochwasser seltene Ereignisse waren, die zufällig kurz hintereinander auftraten, oder ob in Zukunft mit Hochwassern in der beobachteten Grössenordnung oder mit noch grösseren Hochwassern gerechnet werden muss.



Abb.1: Einzugsgebiet der Schüss bis zum Pegel Sonceboz oberhalb von Biel. Ebenfalls eingezeichnet sind Flächen, auf denen Beregnungsversuche durchgeführt wurden, und die räumliche Verteilung von Flächen mit unterschiedlicher Abflusscharakteristik, sogenannte Abflusstypen.

Die Abflüsse der Schüss werden seit 1961 am Pegel Sonceboz oberhalb von Biel gemessen. Dieser Pegel erfasst zwei Drittel des 213 km² grossen Einzugsgebietes der Schüss (Abb.1). Die Messreihe ist jedoch zu kurz, um mit statistischen Untersuchungen allein auf die Grösse seltener Extremhochwasser und das Risiko für die Stadt Biel zu schliessen. Die Hydrologie der Schüss musste deshalb in einem grösseren Rahmen betrachtet werden.

Die massgebenden Abflussprozesse im Einzugsgebiet der Schüss bei grossen Hochwassern wurden untersucht. Im folgenden wird gezeigt, wie aus verschiedenen Teilaspekten (Historische Hochwasser, Ganglinienanalyse, Geologie und Pedologie, Berechnungsversuche) Erkenntnisse über Abflussentstehung, Speicher- und Retentionseigenschaften der Böden, Ausdehnung der beitragenden und nichtbeitragenden Flächen, und weitere hochwasserauslösende Faktoren gewonnen wurden. Mit dem hydrologischen Modell, das anschliessend vorgestellt wird, konnten diese Vorstellungen überprüft, präzisiert und ergänzt werden. Das Modell erlaubte es auch, die massgebenden Abflussprozesse zu extrapolieren und Extremhochwasser abzuschätzen.

2. Massgebende Prozesse bei der Entstehung extremer Hochwasser

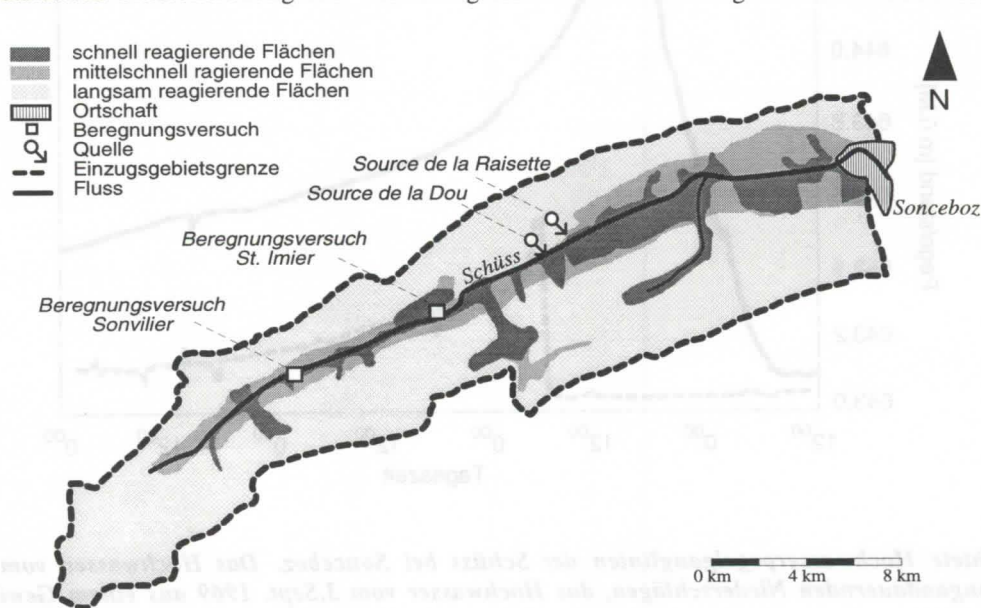
Auswertung historischer Hochwasser

Erste Hinweise auf die Reaktionsweise des Einzugsgebietes lieferte eine Untersuchung der historischen Hochwasser. Aus Archiven und Zeitungen wurden Informationen über Hochwasser zusammengetragen. Das früheste in den Zeitungen erwähnte Hochwasser fand 1863 statt. Durch Berücksichtigung der historischen Hochwasser konnte der überblickbare Zeitraum somit auf 130 Jahre ausgedehnt werden. In dieser Zeitspanne traten insgesamt sechs Hochwasser auf, deren Spitzenabfluss in der gleichen Grössenordnung wie bei den Hochwassern von 1990 oder 1991 lagen. Alle grossen Hochwasser fanden im Winterhalbjahr statt, meist verbunden mit Schneeschmelze.

Das Abflussverhalten bei beobachteten Hochwasserereignissen

Die grossen bekannten Hochwasser der Schüss wurden durch mehrere Tage dauernde Niederschläge verursacht (Abb.2). Bei Gewitterregen reagiert nur ein kleiner Teil des Einzugsgebietes und verursacht einen rasanten Anstieg gefolgt von einem schnellen Rückgang des Abflusses. Grosse Teile des Einzugsgebietes reagieren auf kurze Niederschläge nicht. Der Spitzenabfluss ist daher bei einem solchen Ereignis unbedeutend. Der Knick im abfallenden Ast der Abflussganglinie ist typisch für ein Einzugsgebiet mit unterschiedlich reagierenden Speichern (Abb.2).



Abb.2: Beobachtete Hochwasserpegelganglinien der Schüss bei Sonceboz. Das Hochwasser vom 22.Dez. 1991 entstand aus langandauernden Niederschlägen, das Hochwasser vom 3.Sept. 1969 aus einem Gewitterregen.

Geologie und Pedologie

Die Hügel und Talflanken des Einzugsgebietes bestehen aus sehr durchlässigen Kalkformationen. Eher undurchlässige tertiäre Ablagerungen bilden den Talboden. Aufgrund geologischer, hydrogeologischer und bodenkundlicher Kriterien wurde das Einzugsgebiet in hydrologisch ähnlich reagierende Flächen, sogenannte Abflusstypen, eingeteilt (Tab.1). Die räumliche Verteilung dieser Flächen ist in Abb.1 dargestellt.

Abflusstyp	Untergrund	Standort
schnell	tonige Grundmoräne über tertiären Sedimenten	gerinnenahere Bereiche oder Mulden und Täler, die als bevorzugte Wasserleitlinien dienen
mittelschnell	tonige Grundmoräne über tertiären Sedimenten mit teilweiser Gehängeschuttüberdeckung	gerinneferne Flächen oder Talauen mit guten Retentionseigenschaften
langsam	stark verkarstete Malmkalke	gerinneferne Flächen mit unterirdischer Entwässerung, Hochplateaus

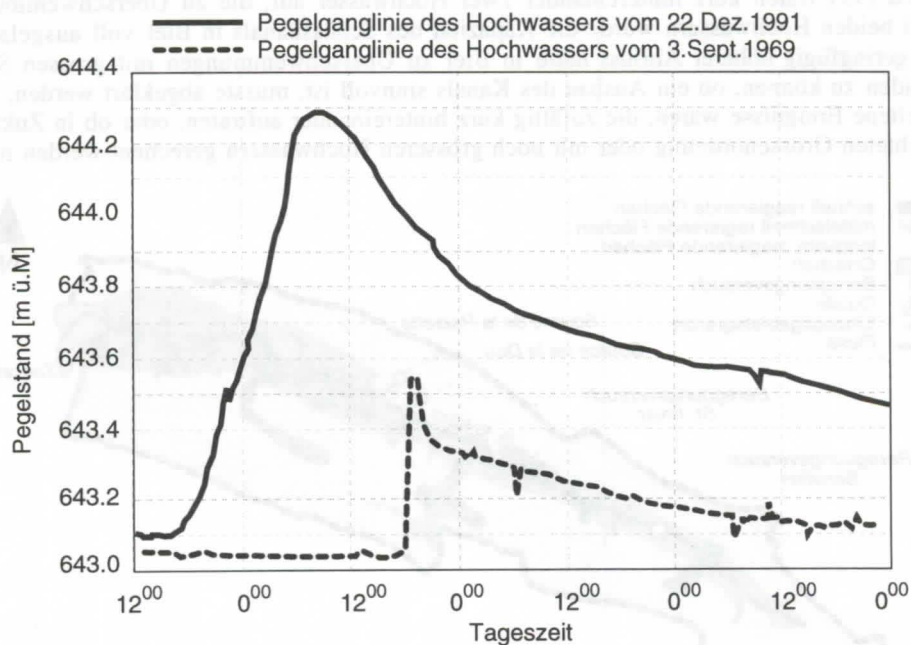
Tab.1: Hydrologisch ähnlich reagierende Flächen im Einzugsgebiet der Schüss

Beregnungsversuche

Um das Abflussverhalten der Böden besser beurteilen zu können, wurden auf je einer Fläche des schnell und des mittelschnell reagierenden Abflusstyps Beregnungsversuche durchgeführt. Die Versuchsfläche in Sonvilier repräsentiert den schnell reagierenden Abflusstyp, diejenige in St. Imier den mittelschnell reagierenden. Beregnungsversuche auf einer verkarsteten Fläche in Blauen (Kanton BL, Koordinaten: 606'300/254'625) dienten als Grundlage für die Beurteilung der Abflussreaktion der langsam reagierenden Flächen (Abb.1).

Beregnung wurden Flächen von 60 m² über mehrere Stunden mit Niederschlagsintensitäten zwischen 65 und 100 mm/h. Gemessen wurde der Oberflächenabfluss und der Abfluss im Boden. Abb.3 zeigt den unterschiedlichen Verlauf der Abflussreaktion auf den drei Abflusstypen. Die beiden Beregnungsversuche im Einzugsgebiet der Schüss bestätigten die Zuteilung der beregneten Flächen zum schnellen bzw. mittelschnellen Abflusstyp. Die Fläche in Sonvilier reagierte deutlich schneller und intensiver als diejenige in St. Imier. Bei beiden Flächen ist Oberflächenabfluss der dominierende Abflussvorgang. Auf der verkarsteten Fläche in Blauen wurde auch nach mehrstündiger Beregnung mit einer Gesamtniederschlagssumme von 250 mm praktisch kein Oberflächenabfluss gemessen. Solche Böden vermögen grosse Wassermengen zu speichern.

Die Beregnungsversuche wurden im Rahmen eines Nationalfondsprojektes durchgeführt; die Methodik sowie weitere Beregnungsversuche sind in SCHERRER (1996) und FAEH (1997) beschrieben.



Abb.3: Änderung des momentanen Abflusskoeffizienten (Verhältnis von Oberflächenabfluss zu Niederschlagsintensität zu einem bestimmten Zeitpunkt) im Verlauf von Beregnungsversuchen in St. Imier, Sonvilier (beide im Einzugsgebiet der Schüss, vgl. Abb.1) und in Blauen (Kanton BL, Koordinaten: 606'300/254'625). Der Beregnungsversuch in Blauen diente als Grundlage für die Beurteilung der Abflussreaktion der verkarsteten Flächen.

3. Hydrologisches Modell

Aufgabe und Aufbau des Modells

Um die erarbeiteten Vorstellungen von der Hochwasserentstehung im Einzugsgebiet zu überprüfen, wurde ein Schneeschmelz-Niederschlag-Abfluss-Modell entwickelt. Dieses berechnet die Abflüsse der Schüss beim Pegel Sonceboz auf der Basis von Niederschlag auf verschiedenen Höhenstufen, unter Berücksichtigung von Schneeschmelze und Evapotranspiration. Speicherung und verzögerte Abgabe des abflusswirksamen Niederschlags durch schnell reagierende, verzögert reagierende und stark verzögert reagierende Flächen wurden durch drei lineare Speicher simuliert. Jedem Speicher wurde ein maximales Speichervolumen zugeordnet. Gefüllte Speicher haben keine Retentionswirkung mehr und geben den abflusswirksamen Niederschlag ohne Verzögerung an den Vorfluter ab.

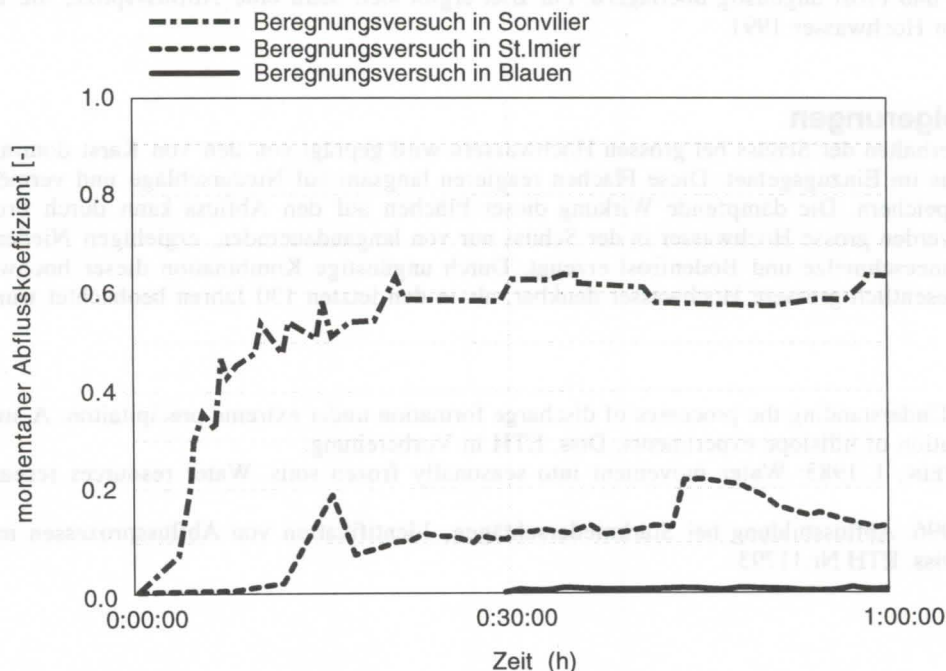
Berechnungen

Mit dem Modell wurden acht Hochwasser nachgerechnet. Zusätzlich zu den Abflussmessungen der Schüss bei Sonceboz standen ab 1978 Abflussmessungen der zwei Quellen Source de la Raisette und Source de la Dou zur Verfügung (Abb.1). Sie widerspiegeln den Ausfluss aus dem langsamen Speicher und wurden bei der Modelleichung mitberücksichtigt.

Nicht befriedigend konnte die Simulation der beiden grössten Hochwasser 1990 und 1991. Die berechneten Abflüsse der Hochwasser waren wesentlich tiefer als die beobachteten. Eine Analyse der Daten zeigte, dass diesen Ereignissen eine Kälteperiode voranging mit Bodentemperaturen unter 0°C. Da sich Infiltration und Wasserleitfähigkeit eines Bodens bei Frost vermindern, vor allem wenn der Boden einen hohen Feuchtegehalt aufweist (KANE & STEIN, 1983), kann angenommen werden, dass Frost in Teilen des Einzugsgebietes eine Erhöhung des Abflusses bewirkte.

Die weiteren Ergebnisse der Berechnungen lassen sich wie folgt zusammenfassen: Die schnell und die mittelschnell reagierenden Speicher werden schon von Niederschlägen kleiner Jährlichkeit gefüllt und verlieren ihre Wirkung. Die Abflussbildung wird vom langsam reagierenden Speicher mit seinem grossen Speichervermögen gesteuert. Da sich die schnellen Speicher rasch entleeren und der langsame Speicher nie vollständig gefüllt ist, beeinflusst ein Vorregen die Grösse eines Hochwassers nur unwesentlich.

Niederschlag, Schneeschmelze und Frost als hochwasserauslösende Faktoren

Grundsätzlich lassen sich drei Typen von Hochwassern unterscheiden: Hochwasser, die durch extreme Niederschläge allein ausgelöst werden (Bsp.: Hochwasser 1987), Hochwasser, die durch extreme Niederschläge in Verbindung mit Schneeschmelze ausgelöst werden, und solche, die durch Niederschläge in Verbindung mit Schneeschmelze und Frost ausgelöst werden (Bsp.: Hochwasser 1990 und 1991). Schneeschmelze allein kann kein grosses Hochwasser auslösen, aber erheblich dazu beitragen.

Extrapolation

Mit dem hydrologischen Modell lässt sich ein Ereignis simulieren, bei dem sich die Faktoren Niederschlag, Schneeschmelze und Frost ungünstig überlagern. Für Biel ergibt sich dann eine Abflussspitze, die um rund 70% höher liegt als beim Hochwasser 1991.

4. Schlussfolgerungen

Das Abflussverhalten der Schüss bei grossen Hochwassern wird geprägt von den von Karst dominierten Talflanken und Hochplateaus im Einzugsgebiet. Diese Flächen reagieren langsam auf Niederschläge und vermögen grosse Wassermengen zu speichern. Die dämpfende Wirkung dieser Flächen auf den Abfluss kann durch Frost beeinträchtigt werden. Daher werden grosse Hochwasser in der Schüss nur von langandauernden, ergiebigen Niederschlägen in Verbindung mit Schneeschmelze und Bodenfrost erzeugt. Durch ungünstige Kombination dieser hochwasserauslösenden Faktoren sind wesentlich grössere Hochwasser denkbar, als in den letzten 130 Jahren beobachtet wurden.

Referenzen

- FAEH, A. 1997. Understanding the processes of discharge formation under extreme precipitation. A study based on the numerical simulation of hillslope experiments. Diss. ETH in Vorbereitung.
- KANE, L.K. & STEIN, J. 1983: Water movement into seasonally frozen soils. Water resources research, vol.19, no.6, pp.1547-1557.
- SCHERRER, S. 1996. Abflussbildung bei Starkniederschlägen, Identifikation von Abflussprozessen mittels künstlicher Niederschläge. Diss. ETH Nr.11793.

Eaux souterraines et évaluation des risques liés à l'exploitation des carrières en pays karstiques

par Pascal Jeanbourquin

Ch. de la Reine-Berthe 10, CH-1009 Pully

Abstract

One can postulate that the environmental impact of open quarries is important, particularly in regards to groundwater. Therefore, the Swiss Water Law has recently forbidden quarrying in groundwater protection zones of springs and water-catchments (zones S, Art. 44, Leaux 1991). In the karst massifs, evaluate the groundwater vulnerability is a puzzling problem because of the strong heterogeneity and anisotropy of the massifs that contain the aquifers. The consequence is that the groundwater protection areas show a very large extent and they interfere a lot with the human activities. Therefore, the risk assessment of diverse anthropic activities needs a special attention in such karst areas.

The present work is a short-term expertise (three months) of the technical dangers and the geological and hydrogeological vulnerabilities of four limestone quarries in the Jura bernois (Switzerland). Its ambition is to point out the specific hazards of the quarrying work, and possibly to compare them with other human activities such as the agriculture or the traffic of vehicles. Hence, this work is divided in five parts: 1- the risk assessment, 2- the description of dangers, 3- the geological approach of the groundwater vulnerability, 4- the assessment of dangers, hazards and risks of four quarries and 5- a comparison, focused on the hydrocarbures, with the traffic and the agriculture.

The risk assessment has been divided in six levels (1-6) or three main levels: A- working hazard (1= danger 2= probability of occurrence), B- geological vulnerability (3= seepage sensitivity and 4= karst vulnerability), and C- the economic risk (5 and 6, the socio-economic potential consequences). This approach allows to compare different hazardous activities at several levels.

This study brings to light two main hazards of the quarrying work: 1- the use of large amounts of hydrocarbures (mostly diesel), 2- the filling and the rehabilitation of the site.

The presence of HC is a potential risk for the water resources in the karst. However, the respect of elementary safety rules and the regard of usual precautions in manipulating HC, allow to reduce the geohazard to a very low level. Comparing with the geohazard of vehicles traffic and agriculture, the quarrying geohazard is lower and it has the advantage to be well localized in space and time, and therefore to permit easy supervision and action.

The experience shows that the filling and the rehabilitation of the site presents a high potential of risk for the future because the checking of the incoming materials is still weak and loose. Simultaneously, the authorized infilling materials are not well defined. Consequently, it is urgent to establish quality rules for this infilling activity and to set up a control procedure that would permit to bring closer the theory and practical reality.

In a general way, quarrying in the karst does gain a reputation for sound quality in respecting a few simple technical and environmental rules.

1. Introduction et buts

Les exploitations rocheuses telles que les carrières en pays calcaire, font peser un risque particulièrement important sur l'environnement et sur les eaux souterraines. Cette affirmation, qui transparait notamment au travers des lois sur l'environnement et de leur application (ex. en Suisse: LEAUX 1991), repose souvent sur un acquis de données fragmentaires, non-exhaustives et une démarche peu objective. Dans une étude systématique de quatre carrières du Jura bernois (Suisse), on a essayé de nuancer cette affirmation par une approche systématique du risque et une comparaison avec d'autres activités anthropiques telles que le trafic routier ou les exploitations agricoles. Le présent

article est la synthèse de cette étude qui a été réalisée pour le WEA du canton de Berne; elle a été présentée à l'EPFL dans le cadre d'un cycle post-grade (Jeanbourquin 1996).

2. Evaluation des risques

En raison de l'ambiguïté de la conception actuelle en matière de risques naturels (ou anthropiques) et de la terminologie qui l'accompagne ("danger, aléa, risque", "hazard and risk", Gefahr), il a été développé une approche du risque adaptée aux eaux souterraines du milieu karstique qui est basée sur trois niveaux, chacun d'eux étant subdivisé en deux sous-niveaux (fig. 1).

Niveau 1

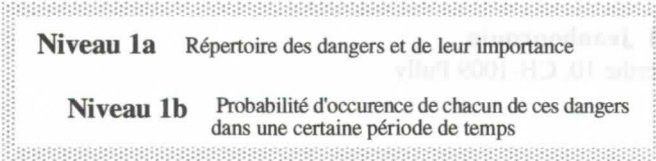

$D_i, i=1...n,$
pour n dangers

$P_i, i=1...n,$
pour n dangers

$$R_p = \sum_{i=1}^n R_{pi} \text{ avec } R_{pi} = D_i * P_i$$

Niveau 2

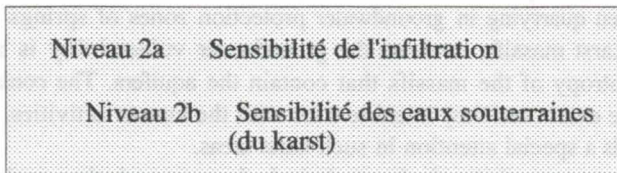

F_{si}

Facteurs de sensibilité

F_{sk}

Risque pur de pollution des massifs rocheux

$$R_{pm} = R_p * F_{si}$$

Risque pur de pollution des eaux souterraines

$$R_{pe} = R_{pm} * F_{sk}$$

Niveau 3

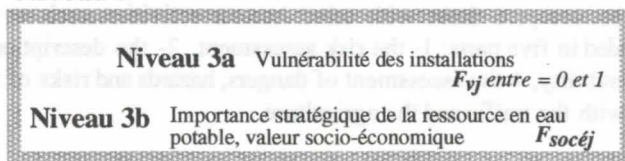

$$R_{pe} * \sum_{j=1}^m F_{vj} * F_{socéj} = F_{socécon}$$

avec $j = 1-m,$
pour m sources ou captages

Risque total, socio-économique

Figure 1: la pyramide du risque. Evaluation des risques liés à l'exploitation des carrières en pays calcaire.

Niveau 1: -risque pur de l'activité humaine. Analyse des causes de danger, de l'importance de chaque danger et de la probabilité d'occurrence des événements dangereux.

a- L'évaluation d'une carrière, à la fois technique et environnementale, permet de reconnaître les causes possibles d'accidents ou d'activités régulières qui présentent des dangers potentiels pour l'environnement. Il faut ensuite spécifier l'importance de chacun des dangers répertoriés par un facteur de proportionnalité. On obtient ainsi une valeur D pour chaque danger pris individuellement, d'où $D_i, i = 1...n$ pour n dangers.

Exemple: $D_1 = 1$ = écoulement sur le terrain de quelques litres d'hydrocarbure (HC) (fuite de diesel <20 l. lors de manipulations) ou encore $D_2 = 5$ = fuite sur le terrain de quelques milliers de litres de HC suite à un accident important (A_i , par exemple éclatement d'une citerne).

b- Après avoir défini les causes, il faut évaluer la probabilité d'occurrence de chacun d'événements dangereux décrits ci-dessus. Suivant les cas on peut se baser soit sur la fréquence historique des accidents, soit sur le rythme de travail ou encore sur la qualité de l'exploitation. Par exemple, pour le danger D_1 (ci-dessus), la probabilité d'occurrence est fonction de la qualité d'exploitation (manipulation des HC dans une aire protégée adéquate)

alors que pour le danger D_2 , il faut tenir compte de la fréquence historique et de la qualité d'exploitation. On note P = probabilité d'occurrence de l'événement dangereux D_i avec $P_i, i = 1...n$, pour n dangers. Exemple: pas de citerne $P = 0$, sinon $0 < P \leq 1$ suivant les cas.

Niveau 2: facteurs de risque liés à la configuration géologique et hydrogéologique de la région

a- F_{si} = facteur de sensibilité à l'infiltration du terrain et capacité de rétention des premières couches de sol. Ce facteur est important dans le cas des carrières puisque le sol "protecteur" est absent. Cependant, par l'activité des machines, il peut se former dans certaines exploitations un tapis plus ou moins étanche (conductivités hydrauliques évaluées à 10^{-6} à $10^{-7} \text{ m}^3/\text{m}^2/\text{s}$). Ce facteur doit aussi être calibré selon l'état du massif rocheux dans lequel est taillée la carrière. Pour les carrières étudiées on a retenu empiriquement, en fonction de l'ouverture des canalisations karstiques et des propriétés des tapis de fond, un éventail de valeurs de 0,5 à 3 avec un incrément de 0,5.

b- F_{sk} = facteur de sensibilité des écoulements souterrains. Ce facteur doit rendre compte de la complexité du milieu karstique vis à vis des écoulements souterrains et des différents types d'interactions entre les eaux souterraines et les polluants. Il est à calibrer selon les

caractéristiques des exutoires et/ou des forages existants et selon les propriétés physico-chimiques du polluant (viscosité, densité, solubilité, caractère hydrophobe...) qui sont aussi très déterminantes à ce niveau. Les valeurs proposées vont de 0,5 à 3 avec un incrément de 0,5. Par exemple, on a choisi $F_{sk} = 0.5$ à 1 pour du diesel dans un massif sain dont les sources principales reflètent un transit dans le karst noyé et $F_{sk} = 2$ à 3 dans le cas d'un polluant soluble dans l'eau et dont le massif montre des relations directes et rapides avec les exutoires.

Niveau 3: facteurs influençant les risques socio-économiques ($F_{soc-écon}$).

a- F_{vj} = vulnérabilité des installations (1 si il y a des captages, 0 si la source n'est pas captée avec des valeurs intermédiaires envisageables suivant les cas). $J = 1$ à m pour m sources captées ou captages et F_v étant la somme de tous les F_{vj} .

b- $F_{socéj}$ = importance stratégique de la ressource en eau potable, valeur socio-économique à long terme ($0 \leq F_{socéj} \leq 1$).

Ce facteur socio économique est surtout dépendant du domaine politique et de la démarche socio-économique qui l'accompagne.

La combinaison de ces différents facteurs autorise une grande souplesse d'utilisation. Elle permet de définir différents types de risques à différents niveaux et pour des dangers spécifiques. Ainsi il est possible de comparer des risques spécifiques d'une activité anthropique à différents niveaux. Dans la figure 1, quatre types de risque, les plus utiles on été retenus, par exemple:

- risque pur de l'activité (utile pour comparer des activités anthropiques),
- risque pur de la pollution des massifs rocheux (utile pour des évaluations à long terme de l'état de pollution d'un massif),
- risque pur de la pollution des eaux souterraines,
- risque total socio-économique.

	Exploitation	Massif rocheux	Eaux souterraines	Socio-écono.
Carrière 1		$F_{si} = 1$	$F_{sk} = 2$	
Ai. citerne	1	1	2	
Ai. camion c.	2	2	4	
Am. machine	3	3	6	
Am. transport	2	2	4	Source de la Birse: $F_{soc-écon} = 2$
Incident manipul.	2	2	4	Source de la Cuchatte: $F_{soc-écon} = 0,3$
R. matériaux	0 ou 1			
Somme	10 ou 11	10 ou 11	20-22	Birse = 40, Cuchatte = 6, tot. = 46
Carrière 2	20	($F_{si} = 2$) 40	($F_{sk} = 3$) 120	Birse = 240, Cuch. = 36, tot. = 276
Carrière 3	26	($F_{si} = 1$) 26	($F_{sk} = 2$) 52	($F_{soc-écon} = 2,3$) total = 166
Carrière 4	22	($F_{si} = 2$) 44	($F_{sk} = 3$) 132	($F_{soc-écon} = 0,3$) total = 46
Agriculture		$F_{si} = 2$	$F_{sk} = 2$	
Ai. citerne	5	10	20	
Ai. camion c.	6	12	24	
Am. machine	5	10	20	
Am. transport	0	0	0	
Inc. manipul.	6	12	24	
L. matériaux	0 ou 1			
Somme	22	44		Birse = 176, Cuch. = 26, tot. = 202
Trafic		$F_{si} = 2$	$F_{sk} = 2$	
Ai. camion c.	6	12	24	
Am. transport	6	12	24	
Somme	12	24	48	Birse = 96, Cuch. = 14, tot. = 110

Fig. 2 : Synthèse des valeurs de risque pour 4 carrières du Jura bernois, l'agriculture et le trafic (Ai= accident important, Am= accident moyen).

3- Résultats obtenus pour quatre carrières du Jura bernois.

Les quatre carrières étudiées sont toutes situées en zone de protection de sources et captages du canton de Berne (Zones SII or SIII). Pour la comparaison, on a choisi la route cantonale de Pierre Pertuis (trafic) et la région agricole de la Montagne du Droit située au Sud de l'axe Tramelan-Tavannes. Pour chacune de ces situations, l'étude a porté sur:

a- techniques et formes de l'exploitation; ceci a permis de reconnaître les dangers dûs à l'exploitation et d'établir une liste de dangers et de leur probabilité d'occurrence au niveau 1, ainsi que d'évaluer provisoirement le facteur F_{si} de la sensibilité à l'infiltration;

b- la configuration des assises géologiques locales et les comportements hydrogéologiques locaux et régionaux. Ceci a conduit à l'évaluation des facteurs du niveau 2, i.e. le facteur F_{sk} (sensibilité des eaux souterraines) et à la correction du facteur de sensibilité à l'infiltration;

c- la reconnaissance des captages et sources de la région. Etant donné que l'approvisionnement en eau potable du Jura bernois est en pleine évolution, les facteurs du niveau 3 n'ont été discutés que succinctement ($F_{soc\acute{e}con} = F_{vj} * F_{soc\acute{e}j}$).

Parmi tous les dangers que font courir les carrières sur l'environnement, deux principaux ont été retenus:

- A- les accidents de carburants fossiles (essentiellement le diesel),
- B- l'accumulation de matériaux de remblais lors de la remise en état.

En comparaison avec ces deux événements, le risque engendré par les autres activités des carrières paraît mineur, notamment en regard des effets sur les eaux souterraines. A partir de ces deux dangers principaux (A et B ci-dessus), des comparaisons ont été établies après avoir quantifié les facteurs de risques intervenant à tous les niveaux en les calibrant d'une manière assez fruste. Un meilleur calibrage est toujours possible mais nécessite plus de temps. L'ensemble des résultats est résumé dans le tableau de la figure 2.

4. Discussion

Le tableau (fig. 2) permet de comparer les éléments désirés directement. Il s'en dégage le fait suivant: les carrières montrent des risques purs à l'exploitation du même ordre de grandeur, voire même parfois très inférieur au risque pur de l'activité agricole ou du trafic routier. Par contre, le trafic routier entraîne un risque pur considérablement plus élevé que toutes les autres activités étudiées dans ce travail si seul le trafic intégral des véhicules est pris en compte

(poids lourds et véhicules légers, pollution par diesel et en plus avec de l'essence). Par ailleurs, ce tableau montre que si l'exploitant d'une carrière respecte scrupuleusement un formel de normes de qualité durant l'exploitation, le risque pur d'exploitation devient très faible, bien inférieur à toute autre activité anthropique courante (carrière 1).

Concernant les carrières, le risque pur "d'exploitation" résulte d'une activité suggérée par la loi: le remplissage et la réhabilitation du site. En effet, le contrôle de qualité du remplissage est très difficile à gérer; les carrières sont encore trop souvent synonyme de décharge. Les remplissages déjà effectués doivent être considérés comme un risque majeur pour le maintien de la qualité des eaux de source en pays calcaire. Les carrières en voie de remplissage présentent également un risque, inférieur, mais cependant très aléatoire car il est difficile et coûteux de contrôler l'apport des matériaux. Aussi, il est capital d'améliorer et de respecter les formels de contrôle des remplissages actuels en réunissant plusieurs organes de contrôle indépendants: exploitants et transporteurs, administrations (cantonales et fédérales), bureaux privés (technique ou surveillance).

5. Conclusion

Si les exploitations de matériaux rocheux respectent des normes drastiques de qualité, l'acharnement "environnementaliste" qui accable actuellement les exploitants de carrières n'est absolument pas justifié, notamment en comparaison avec des activités humaines courantes, acceptées par tous, comme les déplacements de véhicules automobiles ou l'exploitation agricole du sol.

6. Remerciements

Je remercie l'office de l'économie hydraulique et énergétique du canton de Berne (OEHE/WEA) et l'école polytechnique fédérale à Lausanne (EPFL) qui ont partiellement financé cette étude. Que toutes les personnes qui ont contribué à l'élaboration de ce travail soient également remerciées.

7. Bibliographie

- JEANBOURQUIN, P. 1996. Eaux souterraines et évaluation des risques liés à l'exploitation de carrières en pays karstique. Mémoire 3^{ième} cycle EPFL.
- LEAUX, 1991. Loi fédérale sur la protection des eaux. Suisse, réf. 814.20
- PARRIAUX, A. 1991. Le problème des carrières dans la protection globale de l'environnement avec des exemples de la Suisse. *Bollettino della Associazione Mineraria Subalpina* XXVIII, 731-743.

La structure du karst: apport par l'étude des écoulements lors de phénomènes pluvieux exceptionnels

R. Lastennet (1), J. Mudry (2), C. Emblanch (3).

(1) CDGA Bordeaux I, Bat. de Géologie, Av. des Facultés 33405 Talence

(2) Laboratoire de Géologie Structurale et Appliquée, Fac. des Sciences, 1 place Leclerc, 25000 Besançon

(3) Laboratoire d'Hydrogéologie, Fac. des Sciences, 33 rue Louis Pasteur 84000 Avignon

Abstract

Studies which were undertaken on the Notre-Dame des Anges karst system (Vaucluse, southeastern France) show that in highly hierarchised karst aquifers, with a well-developed epikarstic and infiltration zones, an important part of the outlet discharge is originating in the unsaturated zone. This continuous contribution (« hanging reserve »), because of an early and efficient drainage, allows the recharge of permeable areas of the saturated zone upstream the system. Hydraulic head is transferred to the karst conduits from these areas to the outlet. This involves that annex-to-drainage areas of the downstream system are poorly drained, with as a consequence, an increased clogging and extensive hydraulic discontinuities. These subsystems are slowly emptying, only during low-water periods. Their recharge is ensured either from conduits during high water pressure increases or from local infiltration when karstic organization of the subsystem allows it. Primordial informations can be obtained about this functioning during exceptional rain events, which allow to activate these annex-to-drainage systems and sometimes to modify in the depth the functioning of karst.

Résumé

Les études effectuées sur le système karstique de Notre-Dame des Anges (Vaucluse), montrent que dans les aquifères karstiques fortement hiérarchisés ayant des zones épikarstique et d'infiltration développées, une part importante des écoulements à l'exutoire provient de la « zone non saturée ». Cette contribution permanente (réserve suspendue) grâce à un drainage précoce et efficace permet de recharger des secteurs perméables de la zone noyée en amont du système. Le potentiel hydraulique est transmis à partir de ces secteurs dans les conduits karstiques jusqu'à l'exutoire. Ceci entraîne que les zones annexes dans la partie basse du système sont mal drainées avec pour conséquence un colmatage accru et des discontinuités hydrauliques importantes. Ces sous-systèmes ne se vidangent que lentement et seulement en période d'étiage. Leur recharge provient soit des drains lors de fortes mises en charge soit elle est locale si l'organisation karstique du sous-système le permet. Des informations cruciales sur ce fonctionnement peuvent être obtenues lors d'événements à caractère exceptionnel qui permettent d'activer ces systèmes annexes et parfois de modifier en profondeur le fonctionnement du karst.

1. Introduction

Les études effectuées dans le Vaucluse en France montrent que dans les systèmes karstiques fortement hétérogènes le fonctionnement devient complexe en raison des contributions variables des différents réservoirs aux écoulements. Ces participations, mises en évidence par les traceurs chimiques et isotopiques naturels (MUDRY *et al.*, 1994), dépendent des conditions hydrologiques qui existent à une échelle de temps réduite mais aussi de l'organisation géométrique de l'aquifère, héritage de l'évolution antérieure du système. Dans les aquifères à forte dénivellation les écoulements retardés provenant de la zone épikarstique et de la zone d'infiltration ont un rôle quantitatif et qualitatif important en hautes eaux comme en basses eaux (WILLIAMS, 1983; LASTENNET 1994). La zone noyée, quant à elle, est compartimentée en systèmes annexes (MANGIN, 1975) plus ou moins perméables. C'est avant tout la qualité du drainage mettant en relation les différents secteurs de cette zone qui définira la contribution de ces sous-systèmes aux écoulements.

La caractérisation d'une telle organisation dans la zone noyée reste difficile à démontrer en particulier dans les systèmes fortement hiérarchisés pour lesquels l'exutoire est souvent unique. Ceci entraîne qu'il existe peu d'information directe (outre les forages) sur les secteurs périphériques ou éloignés du drain terminal. L'accès à cette information est cependant possible dans certains cas lors de crues à caractère exceptionnel. Nous avons pu en effet observer dans un karst du Vaucluse, à la suite d'un orage à l'origine des inondations de Vaison-la-Romaine en septembre 1992 (300 mm en 4 heures), la mise en activité de plusieurs sorties d'eau, autre que la source principale pérenne, en aval du système. Le suivi de ces nouveaux griffons au cours de cette période a fourni des informations intéressantes sur le fonctionnement et l'organisation du karst de Notre-Dame des Anges.

2. Le système karstique de Notre-Dame des Anges

Le bassin d'alimentation de cette émergence estimé à 20 km², est difficile à délimiter en raison d'une géologie complexe (calcaires Barrémo-Bédoulien). Il se situe dans le Vaucluse, au nord du mont Ventoux, en périphérie du bassin versant de la Fontaine de Vaucluse (1100 km²). La dénivelée est d'environ de 1600 mètres entre les crêtes du Mont Ventoux (1909 m) et l'exutoire (290 m). Ce dernier se situe en aval des gorges du Toulourenc, à une cote proche du lit de la rivière, ce qui a entraîné des difficultés importantes pour le suivi des débits. Il faut signaler la présence d'une grotte, surmontant le griffon principal pérenne, extrémité du drain terminal reconnu par les spéléologues jusqu'à une profondeur de 100 mètres (Jolivet et Isler en 1990 et 1992).

Le suivi hydrochimique et isotopique réalisé en 1991 et 1992 (figure 1) a montré l'importance des apports provenant de la zone d'infiltration (« réserve suspendue »). Il a mis en évidence les fortes discontinuités de la zone noyée (LASTENNET & MUDRY, 1997). Nous avons ainsi constaté que l'eau à l'exutoire était systématiquement en déséquilibre thermique avec l'encaissant. La température moyenne (12,1°C) calculée sur deux ans est de 1 degré plus froide que la température moyenne de l'air (13°C), ceci malgré une circulation profonde des eaux dans la zone noyée. Du point de vue hydrochimique l'étiage prononcé de l'été 1991 (6 mois) a permis d'identifier un type d'eau qui pourrait correspondre à la vidange de sous-systèmes rarement sollicités. Ces eaux à long temps de séjour se caractérisent par des teneurs élevées en silice et en magnésium et faibles en traceurs provenant de la surface (nitrate et chlorure). La température encore fluctuante à la fin de l'étiage se rapproche des conditions d'équilibre (12,8°C). Au cours du cycle 1992 la pluviométrie reste moyenne mais les pluies sont mieux réparties qu'en 1991. Pendant toute l'année 1992 l'écoulement est influencé par des eaux d'origine superficielle marquées en nitrates et chlorures et riches en carbonates.

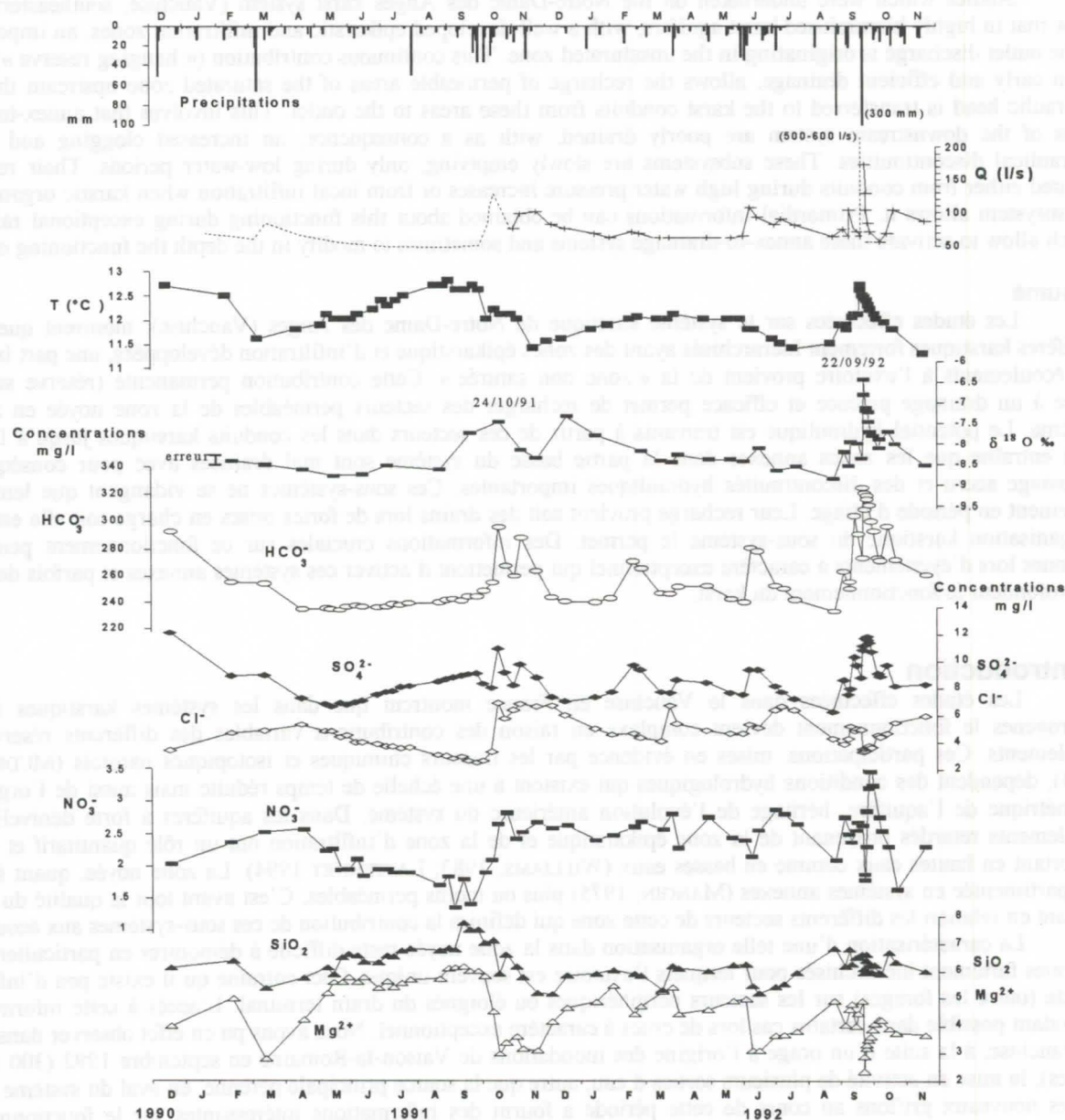

Figure 1 : Evolution de la chimie à N.-D. des Anges au cours des cycles 1991 et 1992.

Ces observations tendent à montrer que le conduit terminal draine majoritairement des eaux situées plus en amont du système. Elles proviennent de secteurs transmissifs, rechargés en permanence par les eaux de la zone non saturée plus froide et marquée plus négativement en oxygène 18. Dans la partie basse du système, les zones périphériques au drain terminal ne participent aux écoulements qu'en période d'étiage prononcé en raison de leur mauvaise connexion hydraulique au drain. En effet, en période influencée le potentiel hydraulique est imprimé avant tout par les eaux de recharge de l'amont du système. Dans le cas de systèmes à zone d'infiltration importante, nous pensons que cette recharge par écoulement retardé est permanente. Il est probable que les variations observées dans les coefficients de tarissement de certains aquifères karstiques viennent de cette alimentation retardée (LASTENNET *et al.*, 1995).

3. Observations lors de la crue du 22/09/1992

Cette crue fait suite à un événement pluvieux d'une rare intensité (300 mm en 4 heures) à l'origine des inondations de triste mémoire de Vaison-la-Romaine. L'impact sur le système a été considérable puisque la forte mise en charge de l'aquifère est à l'origine d'un changement brutal des conditions d'écoulement. Celui-ci est consécutif à un décolmatage important qui a entraîné une modification de la configuration de l'exutoire avec l'apparition d'un nouveau griffon très productif. Outre la modification du régime karstique de cet aquifère (LASTENNET & MUDRY, 1995), nous avons pu observer l'activation d'autres sorties d'eau dans la partie aval du système. Un suivi hydrochimique et isotopique a été réalisé au cours de cette période (figure 2) sur deux griffons, l'un situé en amont (200 mètres) de la rivière Toulourenc, l'autre situé à hauteur de l'exutoire principal du système de Notre-Dame des Anges mais sur l'autre rive de la rivière. Il faut signaler que le début des chémiogrammes de la figure 2 sont légèrement décalés, le 21/09/92 pour l'exutoire principal, le 22/09/92 pour le griffon rive droite et le 23/09/92 pour le griffon amont.

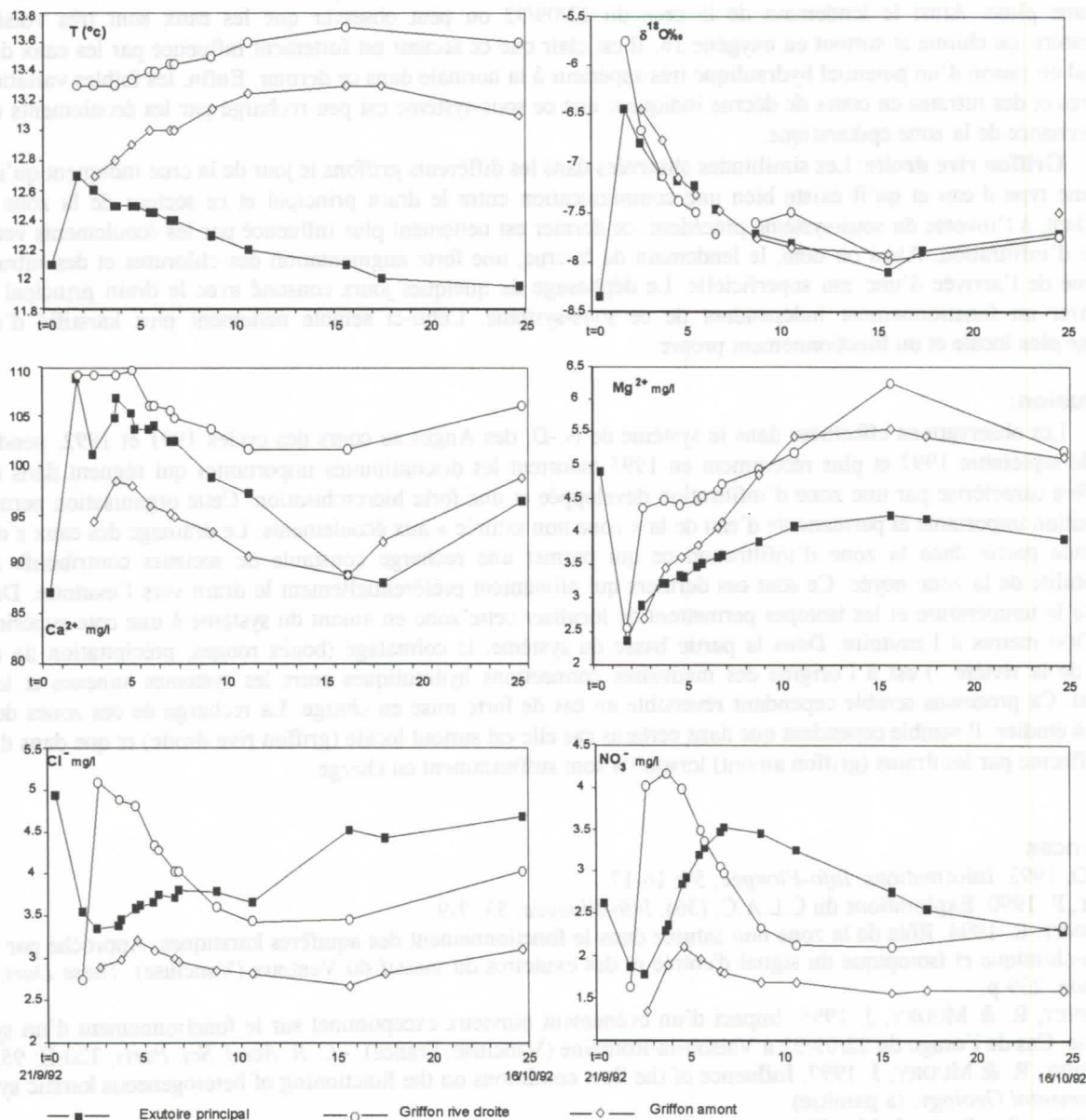

Figure 2 : Evolution géochimique aux exutoires du système de N.-D. des Anges au cours de la crue du 22/09/1992

Exutoire principal : On observe le jour de la crue une augmentation brutale des carbonates et du calcium. Le calcul des indices de saturation a cependant montré des eaux fortement sous-saturées. Ces observations indiquent que les eaux écoulées ne proviennent pas directement de l'orage mais étaient en transit dans le système, en déséquilibre avec la matrice calcaire. Ceci entraîne qu'un potentiel de dissolution important peut être transmis dans la zone noyée lors d'une forte mise en charge. Ces eaux, nécessairement récentes, provenaient de l'infiltration des pluies de deux orages précédant l'événement du 22/09/92. Ces deux épisodes pluvieux (90 mm et 42 mm) n'ont en effet provoqué qu'une très faible

augmentation de débits à l'exutoire, ce qui tend à prouver que ces eaux étaient encore en transit dans le système. L'évolution de l'oxygène 18 corrobore cette hypothèse. Nous avons observé en effet un enrichissement spectaculaire de cet élément au cours de la crue, or les deux orages précédents avaient des teneurs très peu négatives en isotopes lourds (-4,35 ‰). L'évolution des chlorures et surtout des nitrates indique que des eaux d'origine superficielle parviennent à l'exutoire seulement 5 ou 6 jours après l'orage.

Griffon amont: Celui-ci se présente sous la forme d'un boyau circulaire situé deux mètres au-dessus du lit de la rivière. Il draine épisodiquement un secteur de la zone noyée, en aval du système de Notre-Dame des Anges. Un pompage d'essais effectué en 1980 par la DDA a permis de relier hydrauliquement ce griffon au drain terminal du système. Les observations faites au cours d'un suivi réalisé récemment (EMBLANCH, thèse en cours) montrent qu'il s'agit d'un sous-système à l'équilibre thermique (eau proche de 13°C), très stable du point de vue isotopique et très peu influencé par l'infiltration rapide, d'où des teneurs en chlorures et nitrates faibles et constantes. Ces caractéristiques se rapprochent fortement des eaux analysées à la fin du grand étiage de 1991 (figure 1). Ceci laisse penser que ces sous-systèmes ne sont sollicités par le drain terminal qu'en basses eaux. Cette relation s'inverse lorsque le drain est fortement mis en charge après une pluie. Ainsi le lendemain de la crue du 22/09/92 on peut observer que les eaux sont très voisines en température, en chimie et surtout en oxygène 18. Il est clair que ce secteur est fortement influencé par les eaux du drain terminal en raison d'un potentiel hydraulique très supérieur à la normale dans ce dernier. Enfin, les faibles variations des chlorures et des nitrates en cours de décrue indiquent que ce sous-système est peu rechargé par les écoulements différés en provenance de la zone épikarstique.

Griffon rive droite: Les similitudes observées dans les différents griffons le jour de la crue indiquent qu'il s'agit du même type d'eau et qu'il existe bien une communication entre le drain principal et ce secteur de la zone noyée. Cependant, à l'inverse du sous-système précédent, ce dernier est nettement plus influencé par les écoulements venant de la zone d'infiltration. Ainsi on note, le lendemain de la crue, une forte augmentation des chlorures et des nitrates qui témoigne de l'arrivée d'une eau superficielle. Le déphasage de quelques jours constaté avec le drain principal tend à démontrer un fonctionnement indépendant de ce sous-système. Celui-ci semble nettement plus karstifié d'où une recharge plus locale et un fonctionnement propre.

Conclusion:

Les observations effectuées dans le système de N.-D. des Anges au cours des cycles 1991 et 1992, pendant les crues de septembre 1992 et plus récemment en 1995 montrent les discontinuités importantes qui règnent dans ce type d'aquifère caractérisé par une zone d'infiltration développée et une forte hiérarchisation. Cette organisation permet une contribution importante et permanente d'eau de la « zone non saturée » aux écoulements. Le drainage des eaux s'effectue en grande partie dans la zone d'infiltration ce qui permet une recharge constante de secteurs contributifs à forte perméabilité de la zone noyée. Ce sont ces derniers qui alimentent préférentiellement le drain vers l'exutoire. Dans cet exemple la température et les isotopes permettent de localiser cette zone en amont du système à une cote supérieure de 200 à 300 mètres à l'exutoire. Dans la partie basse du système, le colmatage (boues rouges, précipitation de calcite, dépôts de la rivière...) est à l'origine des mauvaises connections hydrauliques entre les systèmes annexes et le drain terminal. Ce processus semble cependant réversible en cas de forte mise en charge. La recharge de ces zones demeure encore à étudier. Il semble cependant que dans certains cas elle est surtout locale (griffon rive droite) et que dans d'autres elle s'effectue par les drains (griffon amont) lorsqu'ils sont suffisamment en charge.

Références

- ISLER, O. 1992. Informations. *Info-Plongée*, 57: 16-17.
- JOLIVET, P. 1990. Explorations du C.L.A.C. (36). *Info-Plongée*, 53: 7-9.
- LASTENNET, R. 1994. Rôle de la zone non saturée dans le fonctionnement des aquifères karstiques. Approche par l'étude physico-chimique et isotopique du signal d'entrée et des exutoires du massif du Ventoux (Vaucluse). *Thèse Doct. Univ. d'Avignon*, 239 p.
- LASTENNET, R. & MUDRY, J. 1995. Impact d'un événement pluvieux exceptionnel sur le fonctionnement d'un système karstique. Cas de l'orage du 22/09/92 à Vaison-la-Romaine (Vaucluse, France). - *C. R. Acad. Sci. Paris*, 320-II: 953-959.
- LASTENNET, R. & MUDRY, J. 1997. Influence of the flow conditions on the functioning of heterogeneous karstic systems. *Environmental Geology*. (à paraître)
- LASTENNET, R.; PUIG, J.-M.; EMBLANCH, C. & BLAVOUX, B. 1995. Influence de la zone non saturée sur le fonctionnement des systèmes karstiques. Mise en évidence dans les sources du Nord-Vaucluse. *Hydrogéologie*, 4: 57-66.
- MANGIN, A. 1975. Contribution à l'étude hydrodynamique des aquifères karstiques. *Thèse Doct. d'Etat, Univ. Dijon, Ann. Spéol.*, 30: 21-124.
- MUDRY, J.; LASTENNET, R.; PUIG, J.-M.; BLAVOUX, B. 1994. Use of natural tracing to understand how an aquifer works. Intake area, recharge fluxes, transit. An example from the Ventoux-Vaucluse karst systems (southeastern France). COST 65, Crampon, N. et Bakalowicz M., eds *Basic and Applied Hydrogeological Research in French Areas*, p. 27-35, EC Brussels.
- WILLIAMS, P. W. 1983. The role of the subcutaneous zone in karst hydrology. in: W. Back and P.E. LaMoreaux (Guest-Editors), *V.T. Stringfield Symposium - Processes in Karst Hydrology, J. Hydrol.*, 61 : 45-67.

The karstic collapse earthquake induced by water storage of Geheyan reservoir in the Qingjiang River, Hubei, China

Shenjifang Wanjunwei Yuqingchun

China University of Geosciences, Wuhan

Liyanyun Xiongzhaoyu Chenrunfa Caijinyan

The company of limited liability of hydroelectric developments of Qingjiang river, Hubei

Abstract

The Geheyan Reservoir is located in karstified carbonate rock areas of South-Western Hubei, China. During the initial stage of water storage, distinct seismic events occurred along with large-scale rises of water level of reservoir in four places on both banks. In less than three months after sealing up the bottom of holes monitoring network of the reservoir, 282 earthquakes were recorded with a maximum magnitude of 3.8.

Combining the spatial distribution pattern of the seismic activities with the geologic environment in the epicenter areas, we consider that Geheyan Reservoir induced earthquakes are caused by the action of underground karst collapses. It is different from that due to surface karst collapses described in the literature. This paper approached the forming mechanism, condition and controlling factors of underground karst collapse, and considered the development tendency of earthquake as a result of karst collapse during reservoir operation.

1. Introduction

The Geheyan reservoir located in carbonate areas of the south-western Hubei is the first phase of the major project for stepped exploitation of the Qingjiang River - a tributary of the Yangtze River. During the initial stage of water storage in 1993, distinct seismic events occurred along with large-scale rises of water level of the reservoir in four places on both banks. In less than three months after sealing up the bottom of holes monitoring network of the reservoir, 282 earthquakes were recorded, of which 118 have located epicenters, the largest magnitude being about 3.8 (M_L). Only by comparing the earthquake above magnitude 1.5 with the regional data over 33 years (the monitoring network has been working since 1959), frequencies per year are 30 times over the perennial average observation value, but the energy released is only 1/10-1/50 the average value from the Xiannushan fault. Combining the spatial distribution pattern of the seismic activities with the geologic environment in the epicenter areas, it is considered that the seisms during the initial stage of water storage of the Geheyan Reservoir should belong to reservoir induced seismicity, which is mainly represented by karstic collapse earthquake.

2. Characters of seismic activities and its geologic environment

According to the macroscopic survey and the instrumental records of the seismic monitoring network, there are four relatively gathering epicenter areas. The strongest shock was felt in the Xiacun village, where occurred the strongest earthquake of magnitude 3.8 in the Geheyan Reservoir area and a following-up aftershock succession (nearly 60 times) during May 30 to 31. Deformations were not seen at the surface, except that some local houses were destroyed. But this seismic regime was not found in the exposed karst area originally monitored from the Xiannushan fault to the dam site.

The Xiacun seismic areas is located in the western sector of the Xiwan anticline in the southern bank of the Qingjiang River. The exposed strata are easily dissolved carbonate rocks in the core of the anticline. Water-conducting faults and basically enclosed boundary of water catchment are favorable to the development of karst. Although the overall development degree of karst is only limited compared with that of the region, because the topography and the tectonic pattern does not completely match the main direction of the underground runoff. But where the Qingjiang River crosscuts the Ordovician strata at the Bashanxia Gorge, groundwater is centralized and discharged in the two sides of the intensely developed fracture belt of the Xiannushan fault. In the Xiacun collecting area, the karst in the lower Ordovician limestone, buried under the middle and upper Ordovician marl, is intensely developed, as well as caves and underground rivers up to 1-3 km long have been found. Other sections close to the river banks do not show similar conditions; therefore the

Xiacun seismic activity is typical for karst collapse earthquake induced by water storage of reservoir and also is the most obvious consequence reservoir-induced seismicity in the Geheyan Reservoir area.

3. Forming mechanism and controlling factors of underground karst collapse

The karst collapse earthquake induced by water storage of the Geheyan Reservoir is due to the following processes. Dry caves originally buried in the vadose zone are rapidly filled with water simultaneously with the rise of water level of the reservoir. The confining beds of cave roofs are submitted to positive hydrofracturing and high pressure impact of compressed air, which result in rock blasting and collapse. The impact-blasting collapse of buried underground karst, which occurs in special enclosed environment with relatively impermeable overlying formations is different from that of surface karst. The forces resulting in collapse are mainly growing gas and water pressure. The former depends on cave scale and increasing velocity of water level, while the latter principally depends on the range of water level fluctuations. The collapse process goes from developing to gradually attenuating, with a remarkable and lasting vibrating effect. While the original large-scale dry caves in the vadose zone are filled with water promptly along with the increase of water level of the reservoir, the air in the caves is compressed and gathers internal energy, then makes a positive impact on the upper cave walls. When the force increases to exceed the permissible compression of the rock masses, the roof rocks are brittly destroyed and collapse, with high sound and vibration consequences. While the ascending water pressure reaches a certain value, pressure burst is made on the wall rocks and then closed microfissures are made open, and pressure on the rock masses is reduced. Impact of the twofold air pressure is superimposed and results in the roofs destruction and collapse. The internal energy of the air is released and reduced with the roofs collapsing and the caves enlarged. Water pressure is also lowered with higher roofs but intermittent impacts and destructions to the roofs continue, but their strength is gradually weakened. When the forces reach an equilibrium with the rock mass intensity, the impact-blasting collapses stop.

The development process of the karst collapses mentioned above shows that it is possible that water storage of reservoir in carbonate rocks area induces karstic impact-blasting collapse, together with earthquakes, as long as there is a certain number of caves in the original vadose zone below the water level of the reservoir. These processes chiefly happened in the stage of large rise of water level during the initial stage of water storage in the reservoir. The controlling factors are :

- (1) Scale, buried depth and enclosed degree of the karst cave.
- (2) Lithological character and tectonic features of the roof rocks.
- (3) Ascending velocity and range of the water level in the reservoir.

Hydrogéologue versus spéléologue, ou de qui relève l'étude et l'exploration des eaux souterraines karstiques ?

par Michel Bakalowicz

chargé des programmes de recherche CNRS-BRGM en hydrogéologie karstique,
CNRS UMR 5569, Géofluides Bassins Eau, Case 057, F-34095 MONTPELLIER CEDEX 5 (France)

Abstract. Tracing tests and sometimes investigations such as exploration of karst conduits for instance, are done by cavers in France in the aim of defining protection areas for karst water supply or exploitation conditions of karst groundwater. The cavers who promote such investigations over all consider that the only direct approach, that of the cave explorer, gives the real knowledge about karst and allows to understand, to exploit and to protect karst groundwater.

After defining the originality of karst and its function as an aquifer, one explains the part of the potential actors of its knowledge, of its exploration and of its management, and especially the part of cavers and of hydrogeologists. That paper tries to define the boundaries of the domain in which the actors take a part. It also indicates to decision makers and to managers that their responsibility is directly engaged when defining the conditions of each other contributions. Investigations and management of groundwater in karst areas absolutely need an obvious definition of the part plaid by cavers and by hydrogeologists. Cavers should not play a direct part in hydrogeological investigations, as it occurs sometimes, but they should contribute to them, in co-operation with hydrogeologists. Proposals are made about cave and karst feature data base and about tracing test experiments.

Résumé. Des expériences de coloration et parfois même des études (reconnaitances de conduits karstiques par exemple) sont entreprises par des spéléologues dans le but de définir des périmètres de protection de captages ou d'exploiter des eaux souterraines du karst. Les promoteurs de cette démarche considèrent avant tout que seule l'approche directe, celle de l'explorateur, permet de connaître, de comprendre, d'exploiter et de protéger les eaux souterraines karstiques.

A partir d'un rappel de l'originalité du karst et de sa fonction d'aquifère, le rôle des différents acteurs potentiels de sa connaissance, de son exploration et de sa gestion est précisé, en particulier celui du spéléologue et celui de l'hydrogéologue. Le but est de tenter de définir les limites d'intervention des uns et des autres et de préciser aux décideurs et aux gestionnaires que leur responsabilité est engagée par leur définition des conditions d'intervention des uns et des autres. Il y va de la crédibilité de chacun des acteurs de l'étude et de la gestion des eaux souterraines karstiques. Plutôt que d'intervenir directement dans des études hydrogéologiques, comme cela se produit parfois, les spéléologues devraient être associés à des hydrogéologues, chaque fois que nécessaire et dans le cadre de leurs compétences.

Il est désormais devenu banal de définir le karst comme un milieu particulier, dont la complexité ne peut pas supporter une simplification qui conduirait à une généralisation des caractères observés ou supposés, dans un modèle universel. En fait, l'originalité du karst tient d'abord à son ambiguïté intrinsèque : s'agit-il d'un paysage, offrant les spectacles naturels parmi les plus extraordinaires de la planète? ou bien d'un monde souterrain, paysage lui aussi, mais renfermant mythes et légendes de l'humanité? ou d'un aquifère, un réservoir, comme il en existe dans d'autres roches, mais avec des particularités, dues au fait que l'eau qui le parcourt modifie considérablement, et rapidement à l'échelle des temps géologiques, les caractères et les propriétés originels des roches aquifères carbonatées? Il est évidemment les trois en même temps, **mais le karst est un paysage souterrain et superficiel parce qu'il est d'abord un aquifère**, parcouru par des eaux souterraines.

Pour ces raisons, l'ambiguïté du karst tient tout autant à cette imbrication des définitions qui peuvent en être données qu'aux auteurs mêmes de ces définitions, qui sont aussi les acteurs de sa connaissance (MARTEL, 1921; GEZE, 1965, 1974; MANGIN, 1974, 1975). Dans la réalité, chacun tend à étendre son champ d'actions au-delà de son domaine, au-delà de ses compétences, en considérant que son approche l'autorise à intervenir dans tous les domaines concernant le karst.

1. La conception spéléocentrique du karst

Pour E.A. MARTEL (1921), le karst souterrain, dont il fut le premier explorateur et observateur attentif, le premier spéléologue, n'était qu'un tube reliant une perte à une source, à l'image de la grotte de Bramabiau, dont il fit un symbole. Sa vision du karst évolua ensuite vers celle de l'égout le jour où il découvrit le "tout-au-karst" et la pollution des sources karstiques (MARTEL, 1925). Du karst, il donna l'image d'un milieu très vulnérable, peu apte à être exploité ou à être aménagé; ses rapports aux Ministères de l'Agriculture et de la Santé publique, ainsi que ses conférences, en témoignent abondamment. Les conséquences de sa vision largement vulgarisée du karst sont encore d'actualité, malgré près d'un siècle d'explorations, d'études et de travaux de toute sorte sur le karst.

En effet, les régions karstiques sont encore souvent considérées par les décideurs et les aménageurs, aussi bien que par les spéléologues et certains défenseurs de l'environnement, comme des régions particulièrement fragiles, où tout aménagement doit provoquer des altérations irrémédiables de l'environnement en général et des ressources en eau en particulier. De ce fait, le développement des régions karstiques a souvent été négligé, alors qu'elles offrent un intérêt économique certain, mais impliquant une politique d'aménagement du territoire adaptée à leurs caractéristiques. Par exemple, dans de nombreuses régions d'Europe, les ressources en eau des aquifères karstiques ont été négligées au profit des autres eaux souterraines et des eaux de surface. Alors que toutes sont exploitées au maximum, sinon même surexploitées, et/ou contaminées plus ou moins gravement,

les eaux des karsts constituent désormais la principale ressource potentielle permettant d'envisager un développement économique.

Aussi, malgré les réticences et les difficultés conceptuelles et méthodologiques d'études des aquifères karstiques, les eaux du karst deviennent un enjeu de la stratégie de développement économique. Ceci est particulièrement vrai pour les régions méditerranéennes, dont l'expansion est importante et les besoins en eau difficiles à satisfaire du fait du contexte climatique particulier. C'est dans ce contexte que sont engagées des études des ressources en eau des karsts et de leur vulnérabilité, ainsi que leur exploitation. Cette évolution, imposée par la nécessité, fait se tourner les décideurs, commanditaires de ces travaux vers tous ceux qui sont concernés par le karst, qu'ils soient spécialisés ou non dans les questions d'écoulements souterrains.

2. Conséquences

C'est ainsi que des expériences de coloration et parfois même des études sont entreprises par des (groupes de) spéléologues dans le but d'aider à définir des périmètres de protection de captages ou en vue d'exploiter des eaux souterraines. Ces travaux s'inscrivent clairement dans la conception martélienne du karst. Ils doivent en outre être rapprochées de prises de position publiques de représentants de groupes spéléologiques affirmant que seule l'approche directe, celle de l'explorateur, permet de connaître le milieu souterrain karstique et, par conséquent, de comprendre, d'exploiter et de protéger les eaux souterraines qu'il contient.

Bien qu'excessif et caricatural, et le fait d'un petit nombre de spéléologues, ce discours est malheureusement pris en considération par certains décideurs mal informés, ou plus préoccupés d'études peu coûteuses et/ou de complaisance. Ces derniers font parfois même appel à certains spéléologues comme conseillers en matière d'eau et d'environnement, alors que leurs compétences en ces domaines sont inexistantes.

Ces spéléologues, explorateurs et connaisseurs des seules cavités souterraines naturelles, outrepassent évidemment leur rôle, comme le faisait déjà E.A.MARTEL. Mais à la différence de cette époque, le karst et les circulations d'eau qui le créent et le parcourent sont beaucoup mieux connus, en partie grâce à ces explorations ; en outre, il existe désormais des spécialistes hydrogéologues maîtrisant les concepts et les méthodes qui permettent d'étudier les eaux souterraines du karst et de proposer des scénarios de leur exploitation et de leur protection, c'est-à-dire de leur gestion durable.

3. Critiques de la conception spéléocentrique du karst

Ces critiques portent sur les concepts eux-mêmes : quelle est l'importance et la représentativité des vides parcourables par l'homme, par comparaison à l'ensemble des vides effectivement parcourus par l'eau souterrains ? Elles portent aussi sur les méthodes d'étude du milieu : l'approche directe est-elle nécessaire et suffisante pour comprendre le fonctionnement hydrologique de l'ensemble ?

En ce qui concerne l'importance des vides spéléologiques, il est connu depuis longtemps qu'ils ne représentent en général en volume que quelques pour-mille, exceptionnellement un pour-cent, du volume total des vides occupés par l'eau. En outre, la plupart du temps, les cavités parcourues par les spéléologues sont abandonnées par les circulations hydrologiques actives correspondant au fonctionnement actuel de l'aquifère : la plus grande partie des grottes connues sont des restes de réseaux de drainage karstique, abandonnés à la suite de modifications

environnementales. Elles informent sur l'histoire du karst, aident parfois à comprendre certains aspects particuliers de son fonctionnement (trop pleins, captures), mais ne permettent pas de décrire le fonctionnement de l'aquifère, ni de définir les ressources en eau, ni de prédire l'existence ou la position de réserves noyées et leur vulnérabilité aux pollutions : les vides spéléologiques ne sont pas représentatifs de l'ensemble du milieu karstique.

En revanche, c'est la connaissance spéléologique du milieu qui a conduit à concevoir le milieu karstique différemment des milieux poreux et fissuré et, ainsi, de contraindre les hydrogéologues à construire des modèles conceptuels prenant en compte ces observations indispensables. En effet, malgré leur modeste contribution au volume total des vides, les vides spéléologiques constituent des éléments remarquables dans lesquels les lois d'écoulement diffèrent très fortement de celles régnant dans les vides de petites dimensions. Les vides spéléologiques introduisent des discontinuités majeures dans la structure et dans le fonctionnement de l'aquifère karstique.

Cette absence de représentativité des vides spéléologiques a pour conséquence que les observations faites directement à leur niveau ne peuvent pas être généralisées à l'ensemble de l'aquifère. Seule l'approche indirecte, par une " auscultation " depuis la surface, est susceptible d'analyser l'aquifère. Mais là réside la véritable difficulté offerte par le karst. Les milieux poreux et fissurés, eux aussi, ne peuvent être analysés que par une approche indirecte, depuis la surface ; mais leur constitution est telle qu'ils peuvent être conceptualisés, ou schématisés, à partir d'un volume de terrain idéal de dimension réduite (un cube de quelques dizaines à quelques centaines de mètres de côté), dans lequel les caractéristiques physiques, et par conséquent hydrauliques, peuvent être considérées comme étant homogènes. C'est le concept de volume élémentaire représentatif (V.E.R.). Des mesures locales, sur les formations géologiques (porosité, fracturation) et dans les forages (caractéristiques hydrauliques), peuvent être généralisées au V.E.R., qui est l'élément de base permettant de constituer le milieu équivalent au milieu réel.

Or, précisément, l'exploration spéléologique fournit des éléments qui permettent d'affirmer que, dans le cas des massifs karstiques, cette conception n'est pas acceptable. C'est de ce constat qu'est parti MANGIN (1975) pour définir le système karstique, unité fonctionnelle de drainage correspondant au bassin d'alimentation d'une source karstique. Le système karstique ne peut pas être réduit à l'assemblage d'un certain nombre d'éléments relativement semblables de façon à le représenter dans sa totalité. C'est pourquoi il ne peut être abordé que grâce à une approche indirecte non pas de la structure de ses vides, par trop non prédictible, mais de son fonctionnement d'ensemble. Il est bien établi que le fonctionnement de l'ensemble est l'expression de l'organisation des écoulements, eux-mêmes responsables de celle des vides (MANGIN, 1975). Aussi, l'organisation des écoulements et des vides du système karstique qu'ils empruntent est reconstituée à partir de l'analyse du fonctionnement de l'ensemble, ainsi que de certaines de ses parties quand cela est possible. Cette démarche est strictement identique à celle du médecin qui, par l'auscultation du patient, définit ses caractéristiques internes et ses éventuels troubles fonctionnels.

La difficulté majeure de cette approche réside dans la nécessité de mise en œuvre d'un nombre important de méthodes, correspondant aux variables susceptibles d'informer sur le fonctionnement du système et de reconstituer ainsi son organisation. Cette approche, qui analyse le fonctionnement pour reconstituer de façon indirecte la structure, est profondément différente de celle qui fut pratiquée par les premiers spéléologues, à l'initiative de Martel. Cette dernière décrit la partie pénétrable

par l'homme et cherche à généraliser ces observations locales à l'ensemble ; elle suppose alors que les conditions d'écoulement observées ponctuellement, assimilées à celles de rivières ou de lacs, sont prédominantes et représentatives de l'ensemble. Pour aisée qu'elle soit à expliquer, cette approche n'en donne pas pour autant une représentation exacte; loin s'en faut.

Il est clair que seule l'approche fonctionnelle peut permettre de construire progressivement un modèle conceptuel cohérent du système karstique étudié. Seule cette approche doit conduire, lorsqu'elle est bien menée, à une connaissance suffisante du système qui fournisse tous les éléments nécessaires à son exploitation et à la définition des règles de sa gestion durable. Une approche inadaptée, comme l'est la conception spéléocentrique, s'appuyant sur une méthodologie impuissante à résoudre les problèmes complexes posés par l'exploitation des ressources du karst, déconsidérera évidemment, par ses échecs, les auteurs de l'étude et des recommandations proposées. Mais, et ceci est bien plus grave, ces échecs inciteront les décideurs, comme ce fut déjà la cas, à négliger les eaux souterraines karstiques et à leur préférer des aménagements de surface, peu respectueux de l'environnement ou mettant en jeu des solutions techniques lourdes et coûteuses pour la collectivité.

4. Les eaux souterraines karstiques : l'affaire des hydrogéologues, avec la contribution de spéléologues

C'est pour éviter ces conséquences, préjudiciables finalement à notre environnement, qu'il faut à la fois tenter de définir les limites d'intervention des uns et des autres (BAKALOWICZ, 1994) et préciser aux décideurs et aux gestionnaires que leur responsabilité est engagée par leur définition des conditions d'intervention des uns et/ou des autres (cahier des charges des études et conséquences sur l'exploitation et la gestion des ressources). Il y va de la crédibilité de chacun des acteurs, décideurs, hydrogéologues et spéléologues, de l'exploration, de l'exploitation et de la gestion des eaux souterraines karstiques.

Un séminaire national " Pour une gestion active des ressources en eau d'origine karstique " (Montpellier, 1996) a permis d'aborder la question de la connaissance et de l'étude du karst en tant qu'aquifère avec tous les acteurs de son exploration, de son exploitation et de sa gestion en France : services publics, agences de l'eau et collectivités territoriales. La place des spéléologues dans ces actions est admise et reconnue par chacun d'eux. Mais elle apparaît parfaitement définie dans le cadre des activités sportives et d'exploration, qui relèvent de leurs compétences. Ces compétences concernent les domaines suivants.

La connaissance des phénomènes karstiques fait partie des informations de base nécessaires à la définition de l'architecture du système karstique et contribuant à la connaissance de sa structure de drainage et de son histoire géologique et environnementale. Cette connaissance s'appuie, entre autres, sur les inventaires de cavités et sur leurs caractéristiques morphométriques, c'est-à-dire sur des documents établis exclusivement par les spéléologues. Dans une démarche prémonitoire et de pionnier, H. Paloc créa dans les années soixante, sous l'égide du Bureau de Recherches Géologiques et Minières (BRGM) une banque nationale de données relatives au milieu souterrain karstique (cavités et sources). Cette banque de données, malheureusement délaissée actuellement, devrait être réactivée, remise à jour et informatisée, car elle présente un intérêt national certain pour toutes les opérations d'aménagement des territoires karstiques. Mais contrairement à la démarche initiale, reposant sur des contributions individuelles et volontaires, cette tâche devrait être menée dans un cadre

contractuel, sur des objectifs sélectionnés en fonction de leur intérêt environnemental et/ou économique. Des " cadastres " spéléologiques sont en cours de constitution dans certains pays européens, où la masse de données existantes reste cependant très inférieure à celle disponible en France.

Par ailleurs, la haute technicité souvent nécessaire pour parcourir les cavités naturelles en pleine sécurité impose de recourir à l'assistance de spéléologues confirmés pour assurer l'encadrement de spécialistes, hydrogéologues notamment, devant réaliser des mesures ou des expériences sous terre. Dans le cadre des études hydrogéologiques, il est le plus souvent fait appel à des spéléologues pour réaliser ces travaux.

En revanche, mon expérience me conduit à refuser tout crédit aux expériences de traçage, ou " colorations ", réalisées par des spéléologues. Pourtant, l'activité de traçage artificiel tient une place importante en spéléologie, depuis ses origines. Mais, les nombreux résultats fournis aussi bien par les spéléologues que par la recherche dans ce domaine montrent à l'évidence combien les expériences de traçage artificiel sont difficiles à réaliser techniquement pour fournir des données dignes de confiance. En outre, les exigences environnementales imposent de plus en plus fréquemment que les teneurs en traceur des eaux soient faibles, ce qui nécessite le recours à des méthodes analytiques lourdes et coûteuses et à la prise de précautions très strictes afin d'éviter tout risque de contamination. Ces exigences sont totalement incompatibles avec les moyens techniques dont disposent les spéléologues. C'est ainsi que les résultats de nombreuses expériences réalisées au cours de ces trente dernières années ont été récemment remis en cause, notamment en Autriche (COST 65, 1995) et en France (voir par exemple RICARD & BAKALOWICZ, 1994), pays pionniers en matière de spéléologie et de traçages artificiels.

Enfin, la nécessité de réaliser des traçages dans le cadre stricte d'explorations peut être contesté, dans la mesure où le fonctionnement hydrologique actuel est souvent différent de l'agencement de cavités correspondant à des états anciens de l'environnement du réseau spéléologique. C'est ainsi que l'inventaire des traçages commandé par l'Agence de l'Eau Rhône - Méditerranée - Corse, et mis à jour récemment, sous le prétexte d'être exhaustif, rassemble toutes les expériences de la littérature spéléologique, y compris celles, en nombre non négligeable, dont les résultats sont manifestement erronés; cet inventaire n'a pas été l'objet d'analyses critiques, puisqu'il a été réalisé par les spéléologues eux-mêmes, qui ne disposent pas des moyens, ni des connaissances, notamment hydrogéologiques, pour assurer cette critique.

De plus, l'accroissement des études sur le karst, en relation avec la définition des périmètres de protection de captages et avec quelques grands chantiers (autoroutes, voies ferrées et canaux) conduit à une multiplication des tests de traçage et, par conséquent, à l'apparition de risques d'interférences entre des expériences conduites simultanément et sans concertation. Il est évident que dans ces conditions, les expériences de traçage ne devraient pas pouvoir être entreprises sans qu'une concertation s'établisse entre les différents intervenants du milieu karstique. Il faudrait envisager une déclaration des projets de traçage, aussi bien par les groupes spéléologiques que par les bureaux d'études et les services publics, d'une part pour éviter toute interférence provoquant un échec, d'autre part pour optimiser des opérations lourdes et souvent coûteuses.

5. Conclusions

Au début de la structuration des groupements de spéléologues, les géologues, hydrogéologues et géomorphologues spécialistes du

karst étaient peu nombreux, mais proportionnellement nombreux et actifs dans ces groupements. Leur contribution aux travaux spéléologiques a été considérable. L'évolution des connaissances et des méthodes d'étude, de mesures et d'analyses a progressivement donner une importance moindre aux données spéléologiques dans l'acquisition des connaissances fondamentales sur le karst.

Parallèlement, l'accroissement de la demande sociale en matière d'études et d'expertises sur l'environnement karstique a incité certains spéléologues à étendre leur champs d'activités au-delà de leurs compétences. Un dialogue devrait s'instaurer entre les différents acteurs, et tout spécialement entre des spéléologues, ou leurs représentants, et les hydrogéologues, de service public comme de bureaux d'études, pour éviter la prise de décisions unilatérales, contraignantes (par exemple, demandes d'autorisation d'exploration ou de réalisation de traçages) et pour que soit pris en considération et valorisé le fruit des explorations spéléologiques. En contrepartie, les spéléologues devraient veiller à ce qu'aucun d'entre eux ne prétende intervenir directement dans une étude du milieu karstique, qui concerne les eaux souterraines, leur gestion et leur protection. Par le dialogue, hydrogéologues et spéléologues doivent parvenir à une reconnaissance mutuelle de leurs compétences, qu'ils devraient, le cas échéant, être capables d'associer.

Références.

Bakalowicz, M. 1994. La place des spéléologues dans la connaissance du karst. Introduction au débat. Spelunca Mémoires. 21 : 40-42.

Bakalowicz, M. & J. Ricard. 1994. Karstic aquifers of the Grands Causses (France). Water reserves that must be protected, p. 137-148. Crampon, N. & M. Bakalowicz, COST 65 Action "Hydrogeological aspects of groundwater protection in karstic areas". Basic and applied hydrogeological research in french karstic areas. Montpellier-Millau Workshop, may, 5-8, 1994. European Commission, Directorate-General, Science, Research and Development, Bruxelles.

Bakalowicz, M. & J. Ricard. 1994. Gérer et protéger les ressources en eau du Larzac septentrional. Revue Agence de l'Eau Adour-Garonne. 61 : 19-24.

COST Action 65. 1995. Karst groundwater protection. Final Report, EUR 16547 EN, 446 p.

Gèze, B. 1965. La spéléologie scientifique. Le Seuil, Paris, 190 p.

Gèze, B. 1974. Le "trou" et son environnement. Spelunca Mémoires. 8 : 43-47.

Mangin, A. 1974. Notion de système karstique. Spelunca Mémoires. 8 : 65-68.

Mangin, A. 1975. Contribution à l'étude hydrodynamique des aquifères karstiques. Doctorat ès Sciences naturelles, Université de Dijon, 260 p.

Martel, E.A. 1921. Nouveau traité des eaux souterraines. Doin éd., Paris, 840 p.

Martel, E.A. 1925. La contamination géologique des eaux souterraines. Annales d'Hygiène publique, industrielle et sociale. 1 : 1-48.

5. Conclusions

...

... l'ensemble de la communauté scientifique et professionnelle du karst, il est nécessaire de définir des objectifs communs et de les partager. L'objectif principal est de mieux connaître le karst, son fonctionnement et son rôle dans le cycle de l'eau. Cette connaissance est essentielle pour la gestion durable des ressources en eau souterraine. Il est également important de sensibiliser le grand public et les décideurs sur l'importance du karst et de ses ressources. Enfin, il est nécessaire de promouvoir la recherche scientifique et l'innovation dans ce domaine.

4. Les eaux souterraines karstiques : l'affaire des hydrogéologues, avec la contribution des spéléologues

... La contribution des spéléologues à l'hydrogéologie karstique est essentielle. Les spéléologues ont une connaissance approfondie de la structure et de la dynamique des karstes, ce qui leur permet de apporter des données précieuses aux hydrogéologues. Cette collaboration est particulièrement importante dans les zones karstiques où les données géologiques sont souvent incomplètes. Les spéléologues peuvent également contribuer à la gestion durable des ressources en eau souterraine en mettant en œuvre des programmes de surveillance et de protection. Enfin, leur expertise est précieuse pour la planification et la mise en œuvre de projets de développement durable dans les zones karstiques.

Role of Speleology in Karst Hydrology and Hydrogeology

Ognjen Bonacci,

Faculty of Civil Engineering, University of Split, Matice hrvatske st. 15, 21000 Split, Croatia

Abstract

Technology of speleological investigations enables special measurements of features of underground conduits, caves, pits, jamas, shafts and the other solutional sculpturings such as scallops and cave rocky relief. Speleologic investigations can reveal the positions, dimensions and interactions of underground and surface karst features and water flow in the karst and on its surface. Speleologists are capable of investigating the hydraulic conditions under which laminar or turbulent flows occur in conduits and small and narrow karst fractures. From such investigations crucial parameters for hydraulic, hydrologic and hydrogeologic modelling such as dissolution-bedform and hydraulically-transported sediment, can be obtained. For these reasons, the role of speleology in karst hydrology and hydrogeology should (and undoubtedly will) in future be given much more importance. This paper briefly explains the main theoretical aspects and gives some practical examples and experiences from Dinaric and others karst regions.

Résumé

Ce rôle sera, prochainement, bien plus important que jusqu'à présent. En utilisant les techniques spéléologiques, il est possible d'effectuer les mesures spéciales des formes souterraines karstiques telles que: tubes karstiques, gouffres, grottes et rugosités du fond et des parois des conduits de circulation d'eau. Pour l'établissement des modèles hydrologiques et hydrogéologiques, il est de plus haute importance de connaître la rugosité des parois karstiques et les caractéristiques d'alluvion transporté par l'eau à travers des conduits karstiques. À l'aide de ces informations, il est possible d'identifier le type et les caractéristiques de l'écoulement souterrain karstique. Par les techniques spéléologiques on découvre les positions, les dimensions et l'interaction des formes karstiques de surface et souterraines, donc les principes d'écoulement d'eau en surface et dans le souterrain du karst. La présente étude donne les explications théoriques de base et cite de nombreux cas pratiques du karst des Dinarides.

1. Introduction

The role of speleology in karst hydrology and hydrogeology as well as in karst engineering today is very well-known and unavoidable. The division of the main applicable speleologic explorations in the karst regions can be made in following way: 1 Explorations near traffic structures and quarries; 2 Foundation of civil engineering constructions; 3 Explorations along dams and reservoirs; 4 Grouting in underground hollows; 5 Discoveries during the tunnel excavations; 6 Water intakes from the karst underground; 7 Explorations dealing with karst aquifer protection against pollution. In this paper accent will be put on the special and relatively new role of speleology. The modern speleology may and should play key role in explaining hydraulic, hydrologic, and hydrogeologic processes in karst underground essential for flow modelling.

The limestone aquifers are two-component systems in which the major part of storage is in the form of true ground water in narrow fissures, where laminar flow prevails. On the other hand the majority of water is transmitted through the karst underground by turbulent flows in solutinally enlarged conduits. Slow or so-called diffuse flow occurs through karst fissures of small dimensions generally in the laminar regime. Turbulent fast flow, or conduit flow, occurs in large fissures through irregular karst conduits, with dimensions varying from 1 cm to few meters. Speleological investigations enable the penetration of investigations into karst underground. The space in which the speleologist investigator can enter should have the dimensions appropriate to human body. Because of that, speleology is generally useful in exploration of fast turbulent flow. The diffuse flow characteristics can be controlled very well by piezometers.

Today, primarily thanks to speleology, karst is not "black box" neither for laymen nor for experts. Intensive use of speleology in combination with other scientific branches

can yield precise answers to the position, composition and dimensions of underground karst forms, which serve as main input in complex hydrologic-hydrogeologic models. Shapes of speleologic objects depend on: 1 Lithologic and stratigraphic characteristic of the rocks in which they originated; 2 Intensity and type of tectonic activity; 3 Underground water activity and regional meteorological conditions; 4 Karstification rate and speleogenesis. The relationships between karst hydrology and hydrogeology and speleologic objects is known for a long time. The general knowledge should be investigated in detail because of the specific hydraulic function of each individual speleologic object. Introductory remarks will be finished by quotation of types of speleologic objects: 1 Caves; 2 Pits (jamas or shafts) and 3 Conduits (channels, passages). According to the shape and distribution of connections in speleologic objects next morphologic types can be defined: 1 Simple speleologic object; 2 Branching speleologic object; 3 Speleologic object with different levels; 4 Knee formed speleologic object; 5 Cave or pit systems. Each of these objects can have specific hydraulic, hydrogeologic and hydrologic function.

2. Inflow-Outflow Relationship

Water circulation in karst terrain is characterized by existence of inflow-outflow relation shown in figure 1 (BONACCI, 1987). The speleology can help to resolve some of these complex situations.

Figure 2 represents hydraulic scheme of the simplest inflow-outflow relationship gives as type I on figure 1A.

Under the assumption that water flow through karst conduits is as in the pipes, Bernoulli's equation can be applied:

$$H_I - H_O = \xi_I \frac{v^2}{2g} + \lambda \frac{L}{d} \frac{v^2}{2g} + \xi_O \frac{v^2}{2g} \quad (1)$$

where: ξ_I and ξ_O are dimensionless coefficients defining a losses of velocity head at the entrance-inflow (I) and exit-outflow (O) to and from karst conduit; $v=Q/A$ is mean water velocity through karst conduit in $m\ s^{-1}$; Q is discharge through karst conduit in $m^3\ s^{-1}$; A is cross section of the karst conduit in m^2 ; L is the conduit length in m ; d is the conduit diameter in m ; g is the acceleration of gravity in ms^{-2} ; λ is dimensionless friction factor. Under the assumption that flow regime in karst conduits is complete roughly turbulent (confirmed by many investigators (BÖGLI, 1980; GALE, 1983; WHITE & DEIKE, 1989)) the friction factor λ is defined by Prandtl-Karman's equation :

$$\lambda = \left[1.14 - 2 \cdot \log \left(\frac{\varepsilon}{d} \right) \right]^2 \quad (2)$$

where ε is absolute roughness of the boundary in m . Speleologic investigation can supply us with exact or at least reliable data of L , d or A , ε and v and can give us a glimpse of the karst underground. It is well know that karst conduits have an irregular cross section, differing more or less from a circular section (WHITE & DEIKE, 1989; BONACCI, 1995; SLABE, 1995).

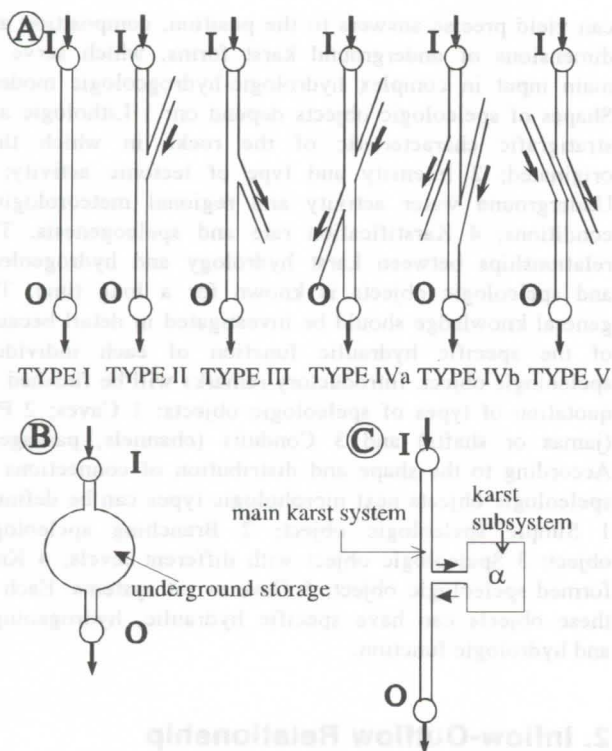

Figure 1: Possible types of relation between inflow (I) and outflow (O) in karst system, A Types of flow network (BROWN & FORD, 1973); B Presence of underground storage; C Connection between main system and its subsystem

It is also necessary to take into account irregularities of cross section in large karst conduits resulting from rock slides and existence of siphons. In addition, occasionally

large caves and significant narrow sections occur along the conduit. Hydraulic consequences of these underground features can be very important for water flow and thus for its mathematical modelling.

Let us return to the equation 1. The most significant influence on the flow governed by it has the term $\lambda (L/D)$ where the conduit length is dominant factor. The determination of exact underground karst length conduit is extremely complicated task which could, for practical engineering purposes, be satisfactory fulfilled using speleologically investigated part of conduit, RICHARDSON's theory (number) (1961), ŠUŠTERŠIČ's (1985) and BONACCI's (1995) suggestions.

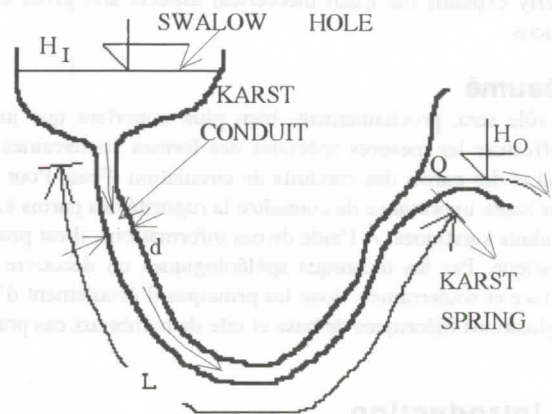

Figure 2: Schematic presentation of inflow (I) -outflow (O) karst hydraulic system

The essential role for hydraulic conditions of flow in karst conduit is also played by scallops (defined as shallow cusped pockets dissolved into cave or conduit walls (WHITE & DEIKE, 1989)) and flutes. Scallops and flutes (CURL, 1974; BÖGLI, 1980; SERBAN, 1987; WHITE & DEIKE 1989; SLABE, 1995) determine absolute roughness of the boundary ε . In figure 3 is presented the foto of scallops taken by Slabe in a underground karst conduit in Dinaric karst of Slovenia. The foto is taken in a karst conduit fulfilled by water, during one of the speleological investigations. WHITE & DEIKE (1989) on page 233 give the relation of the scallop lenght to mean channel flow velocity for conduits of several diameters.

Sensitivity analysis of equations 1 and 2 on their parameters shows that main role is played by diameter d and discharge Q . Both of them can be successfully determined only through the speleological measurements.

3. Other Specific Assistance of Speleology

Many specific and, for engineering practice, key hydrologic and hydraulic problems could be solved by the following procedure: 1 Determination of the flow type (open surface flow or flow under pressure; 2 Determination of hydraulic functioning and role of syphons; 3 Determination of exact ground water level; 4 Determination of hydraulic and hydrologic role of caves; 5 Determination of changes of dimensions and roughnes of karst conduits, and many other.

For example, if in karst conduit exists a short narrow passage it could cause rapid drop of energy line significantly greater than drop of energy line caused by absolute roughness of the boundary in a long conduit sector.

Using measurements in Mendip Hills (U.K.) ATKINSON (1977) defined 1.22 m energy loss of head in karst conduit with length $L = 620$ m and diameter $D = 1.433$ m. Figure 4 gives schematic presentation of idealized circular karst conduit with length of $L = 620$ m and diameter of $D = 1.433$ m. Supposing that flow velocity is $v_1 = 0.047$ m/s as in ATKINSON (1977) case in table 1, BOJANIĆ (1994) calculated values of energy loss: at entrance ΔH_I , at exit ΔH_O and in reduction ΔH_R , for different values of L_s , D_s and v_2 (see figure 4).

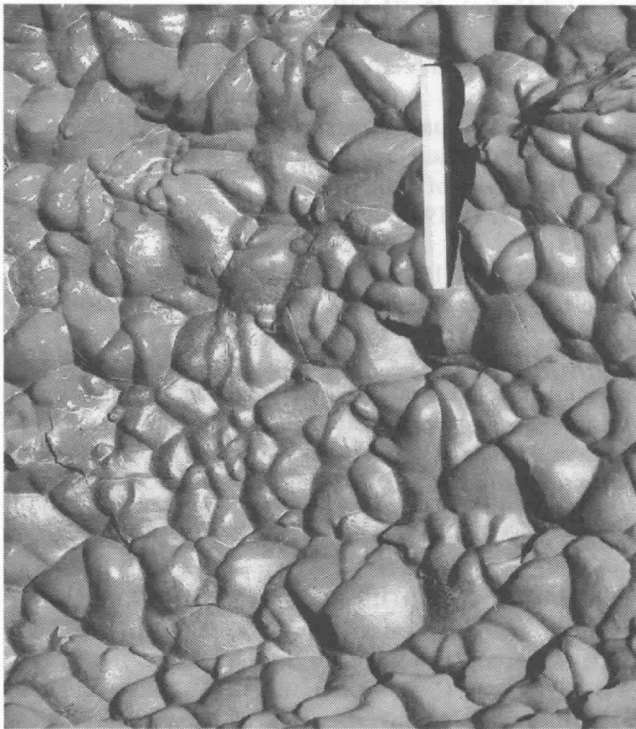

Figure 3: Scallops on intraclastic limestone (Slovenia), scale 15 cm (taken by Slabe)

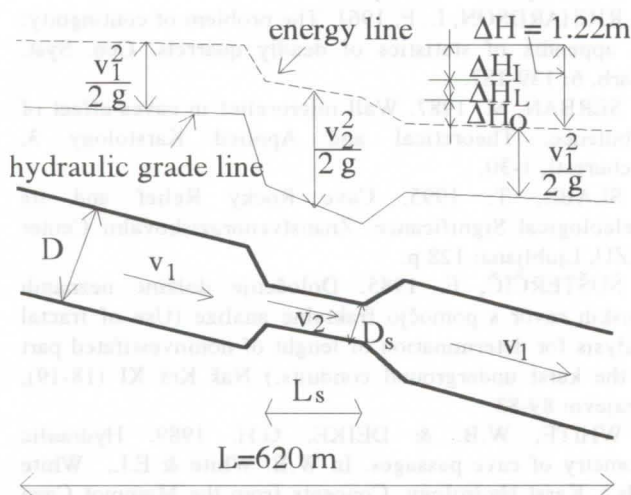

Figure 4: Schematic presentation of idealised circular karst conduit (pipe) with narrow passage

From those results it is possible to see that great part of complete 1.22 m loss of head could be caused by

morphologic characteristics of reduction. These characteristics should be defined by speleologic investigations especially in karst conduit with diameter in excess of 1 m.

Figure 5 shows a cross-section of one real ponor (jama) in Croatian karst. Due to narrow passage designated by A water level in this ponor after the heavy rain and during the wet period is over it. Real maximum ground water level is about 100 m lower. These statements were confirmed by speleological investigations.

L_s [m]	D_s [m]	v_2 [m/s]	LOST HEAD [m]		
			ΔH_I	ΔH_O	ΔH_R
1.0	0.160	3.770	0.072	0.706	0.453
2.0	0.172	3.260	0.054	0.527	0.631
10.0	0.217	2.050	0.021	0.204	0.987

Table 1 Losses of head in karst conduit reduction showed in figure 4

Speleology could play key role in investigation of submarine springs (vruljes) and coastal brackish karst springs. (BONACCI *et al.*, 1995; BONACCI & ROJE-BONACCI, 1997).

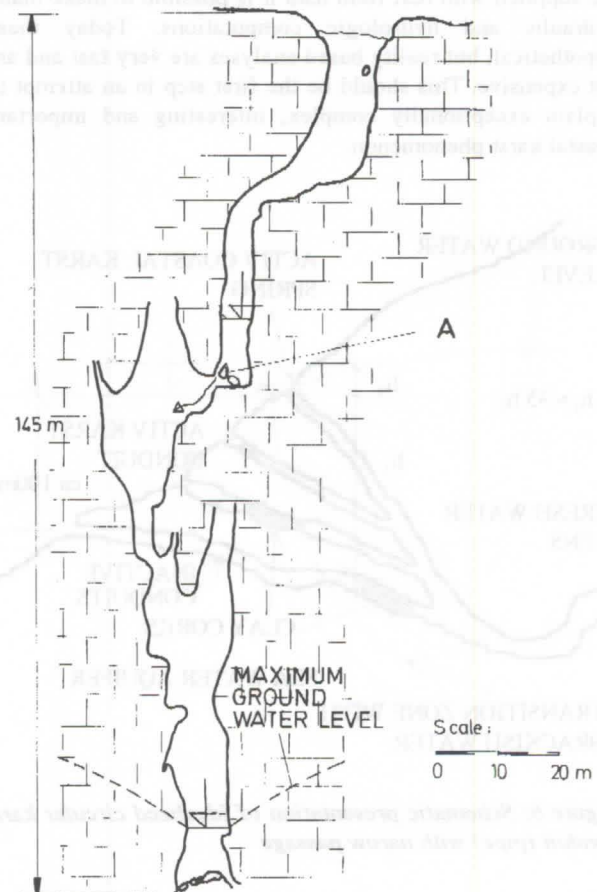

Figure 5: Cross-section through the ponor in Dinaric karst of Croatia

Before approximately 25000 years ago, the level of the Adriatic Sea was about 100 m lower than at present. Then, it represented the erosion basis for the karst area so that the

karst springs appeared at that level. As the sea level was raised the springs come under the sea level, and thus new conduits were simultaneously formed in the karst, together with the new, higher positions of the coastal springs. The change in the position of the springs along the coast depends upon the local geologic structure of the coastal belt. Each actual coastal karst spring has a few conduits. Some of them are active and some are inactive as it is shown schematically in figure 6. The function and dimensions of all conduits is possible to check exclusively by speleologic measurements which should be closely connected with hydrometry. Modern speleology should and could serve for complex multi- and inter-disciplinary investigations of karst. The mechanism of sea water intrusion is relatively well known but the problem of the karst springs desalination is not solved practically. Speleological submarine measurements have showed that morphologically the vruljes correspond to the inundated fossil dolines from the pre-alluvial age formed in the continental phase of the Dinaric coastal karst. The vruljes frequently are only one element of a larger coastal spring system. Due to the fact that the mechanism of the sea water intrusion is directly connected with the position of the karst conduits through which the sea water penetrates into spring exit, it is of great importance to detect exact positions and dimensions of these conduits. The role of speleology in these investigations is indispensable. When the researchers are supplied with real field data it is possible to make many hydraulic and hydrologic computations. Today these hypothetical, but reality based analyses are very fast and are not expensive. This should be the first step in an attempt to explain exceptionally complex, interesting and important coastal karst phenomenon.

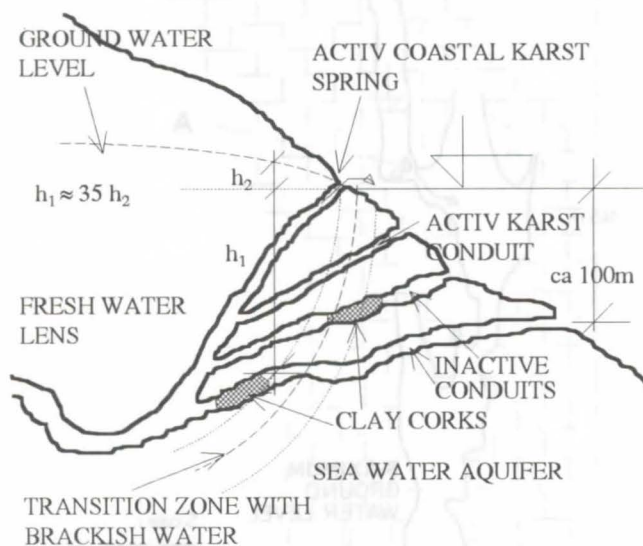

Figure 6: Schematic presentation of idealized circular karst conduit (pipe) with narrow passage

4. Conclusions

The role of speleology in engineering practice and theory should be given much more attention than until now. Speleology represents an exceptionally important source of a wide range of information necessary for all types of investigations related to the regime of karst ground water

circulation. Speleologic investigations represent a real "window" into the underground karst medium and make possible detailed insight which is absolutely necessary for theoretical and applied investigations. The speleologic measurements should be planned, organised and conducted carefully as an unavoidable part of complex multi- and inter-disciplinary karstologic investigations.

References

- ATKINSON, T., C. 1977. Diffuse flow and conduit flow in limestone terrain in Mendis Hills, Somerset (Great Britain). *J. Hydrol.* 35: 93-110.
- BÖGLI, A. 1980. *Karst Hydrology and Physical Speleology*. Springer Verlag, Berlin: 284 p.
- BOJANIĆ, D. 1994. Identifikacija hidrološko-hidrauličkih elemenata otjecanja u kršu (Identification of hydrologic-hydraulic elements of flow in the karst). M. sc. Thesis. University of Split: 100p.
- BONACCI, O. 1987. *Karst Hydrology*. Springer Verlag, Berlin: 184 p.
- BONACCI, O. 1995. Ground water behaviour in karst: example of the Ombla Spring (Croatia), *J. of Hydrol.* 165: 113-134.
- BONACCI, O. 1995. Primjena koncepta determinističkog kaosa prilikom analize vodnih resursa (Application of deterministic chaos concept for water resources analysis). *Zbornik radova 1. Hrvatske konferencije o vodama, Dubrovnik, knjiga 1: 253-265.*
- BONACCI, O., FRITZ, F. & DENIĆ, V. 1995. Hydrogeology of Slanac spring, Croatia. *Hydrogeology Journal* 3 (3): 31-40.
- BONACCI, O. & ROJE-BONACCI, T. 1997. Sea water intrusion in coastal karst springs: example of the Blaž Spring (Croatia), *Hydrology Sci. J.* (in press)
- BROWN, M. C. & FORD, D. C. 1973. Quantitative tracer methods for investigation of karst hydrological system. *Trans. Cave Res. Group GB* 13 (1): 37-51.
- CURL, R. L. 1974. Deducing flow velocity in cave conduits from scalops. *Natl. Speleol. Soc. Bull.* 36/2: 1-5.
- GALE, S. J. 1983. The hydraulics of conduit flow in carbonate aquifers. *J. of Hydrol.* 70: 309-327.
- RICHARDSON, L. F. 1961. The problem of contiguity: An appendix of statistics of deadly quarrels. *Gen. Syst. Yearb.* 6: 139-187.
- SERBAN, M. 1987. Wall microrelief in caves-effect of turbulence. *Theoretical and Applied Karstology* 3, Bucharesti, 1-30.
- SLABE, T. 1995. *Cave Rocky Relief and its Speleological Significance*. Znanstvenoraziskovalni Center SAZU, Ljubljana: 128 p.
- ŠUŠTERČIĆ, F. 1985. Določanje dolžine neznanih jamskih rovor s pomočjo fraktalne analize (Use of fractal analysis for determination of length of noninvestigated part of the karst underground conduits.) *Naš Krš XI* (18-19), Sarajevo: 89-83
- WHITE, W.B. & DEIKE, G.H. 1989. Hydraulic geometry of cave passages. In W.B. White & E.L. White (eds.). *Karst Hydrology, Concepts from the Mammoth Cave Area*. Van Nostrand Reinhold, New York: 223-258.
- WHITE, W.B. 1988. *Geomorphology and Hydrology of Karst Terrains*. Oxford University Press, New York: 464 p.

Wasserrfärbung im Gebiet Gemmenalp-Sieben Hengste: Ziele und Resultate

Ph. Häuselmann und M. Otz

Ph. Häuselmann, Haldenstr. 32, CH-3014 Bern (Schweiz)
M. Otz, Neubrückestr. 17, CH-2555 Brügg (Schweiz)

Zusammenfassung

Mit einer im Jahre 1996 durchgeführten Wasserrfärbung wurde versucht, das Einzugsgebiet der Beatushöhle von dem des benachbarten Systems der Sieben Hengste (nachfolgend Réseau genannt) zu trennen. Gleichzeitig wurde die Färbung von 1984 partiell wiederholt, da einige Zweifel an den damals gemachten Aussagen bestanden. Im nachfolgenden Artikel werden die Resultate aufgezeigt.

Abstract

With a coloration in 1996 we tried to separate the two catchments of the Beatus cave and the neighbouring Cave System of the Sieben Hengste (called Réseau below). At the same time the coloration of 1984 has partially been repeated because of apparently doubtful results. In the following article the actual results are shown.

Geographischer und geologischer Überblick

Die Kette des Niederhorns - Sieben Hengste - Hohgant liegt nördlich von Interlaken und gehört zur helvetischen Voralpenkette. Sie weist eine recht regelmässig nach SE einfallende, flache Flanke und einen senkrechten Felsabbruch im NW auf.

Die für die Höhlenentwässerung massgebliche Schichtfolge setzt sich (von unten nach oben) aus folgenden Gesteinen zusammen:

- Zuunterst liegt der bis zu 200 m mächtige Kieselkalk. Er ist schlecht verkarstungsfähig; es finden sich nur wenige Höhlenteile darin. Dies ist zu einem Grossteil auch durch den überliegenden Drusbergmergel begründet.
- Dieser Drusbergmergel bildet in den meisten Fällen die undurchlässige Unterlage, auf der die Höhlengewässer abfliessen. Er ist bis zu 40 m mächtig und weist in seinen obersten Partien kalkige Einschaltungen auf.
- Es folgt der 160 - 200 m mächtige Schrackenkalk, der das Leitgestein für die Höhlenbildung darstellt.
- Nach einer grossen Schichtlücke, die die oben beschriebenen unterkretazischen Gesteine vom Tertiär trennt, folgen die Nummulitenkalk und der Hohgantsandstein, die stellenweise über 200 m mächtig werden und faziell sehr kompliziert ausgebildet sind. In den kalkigen Bändern des Sandsteins bilden sich oftmals Höhlen, die aber nicht notgedrungen einen Zugang zum oft viel tiefer liegenden Schrackenkalk darstellen müssen.

Die nach SE einfallende Platte ist von einigen Abschiebungen und Blattverschiebungen zerhackt. Die wichtigste Abschiebung ist die Hohgant-Sundlauenen-Verwerfung, die im S 500 m Versatz erreicht und die Einzugsgebiete des Siebenhengste-Höhlensystems und der Beatushöhle trennt.

Die obersten Teile der Schrackenkalkplatte sind stark verkarstet; dementsprechend ist die Höhlendichte gross.

Eine weitergehende Übersicht geben u.a. HÄUSEL-MANN & JEANNIN (1997), HOF *et al* (1985) oder auch BITTERLI (1989).

Frühere Färbungen

Schon früh wurden im Gebiet Färbungen unternommen, um den unterirdischen Fliesswegen auf die Spur zu kommen. Einen guten Überblick über die vorgenommenen Färbungen gibt WILDBERGER *et al* (1982).

Die letzte Färbung wurde 1984 durchgeführt (KLÖTZLI, 1985). Es stellte sich - wie vermutet - heraus, dass Fitzlischacht und

Häliloch in die Beatushöhle entwässern. Es blieben allerdings einige Fragen bestehen, so zum Beispiel trat Fitzlischacht-Farbe in drei - scheinbar - unabhängigen Bächen auf.

Aus diesen Färbungen resultierte die vorgenommene Trennung in zwei Einzugsgebiete, in dasjenige der Beatushöhle (mit Waldheimhöhle, Fitzlischacht, Häliloch als Färbepunkte, Austritt: Beatushöhle) sowie dasjenige des Réseaus (mit Bärenschart und Faustloch als die zwei südlichsten Färbepunkte, Austritt: Bätterich und Gelberbrunnen), so wie auf der Figur 1 dargestellt.

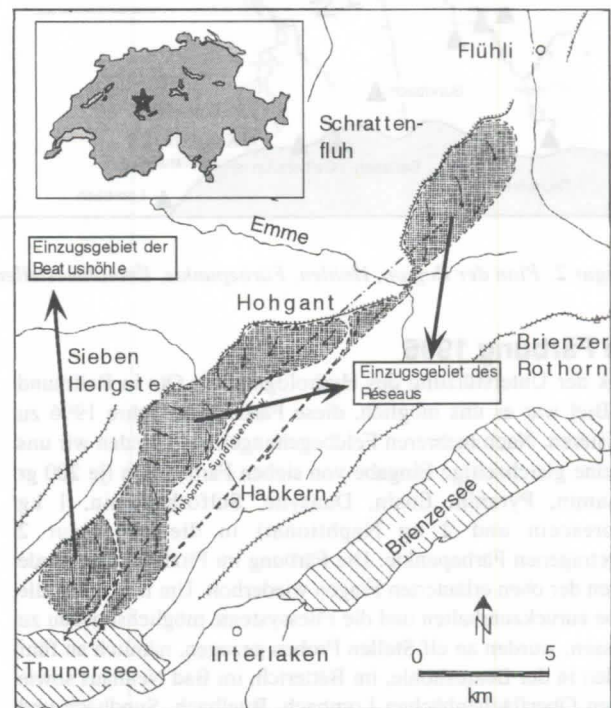

Figur 1: alte hydrologische Karte der Region (nach Bitterli 1989)

Ein grosses Gebiet allerdings wurde nie untersucht, weil sich darin keine grossen Höhlen fanden, da der Schrackenkalk an dieser Stelle von Sandstein bedeckt ist. Doch gerade dieses Gebiet zwischen Häliloch, Bärenschart und A2 (Figur 2) ist interessant, da sich irgendwo darunter die Grenze der zwei Einzugsgebiete befindet. Eine Feldbegehung zeigte mehrere Schlucklöcher und Dolinen. Eine Färbung wäre also machbar!

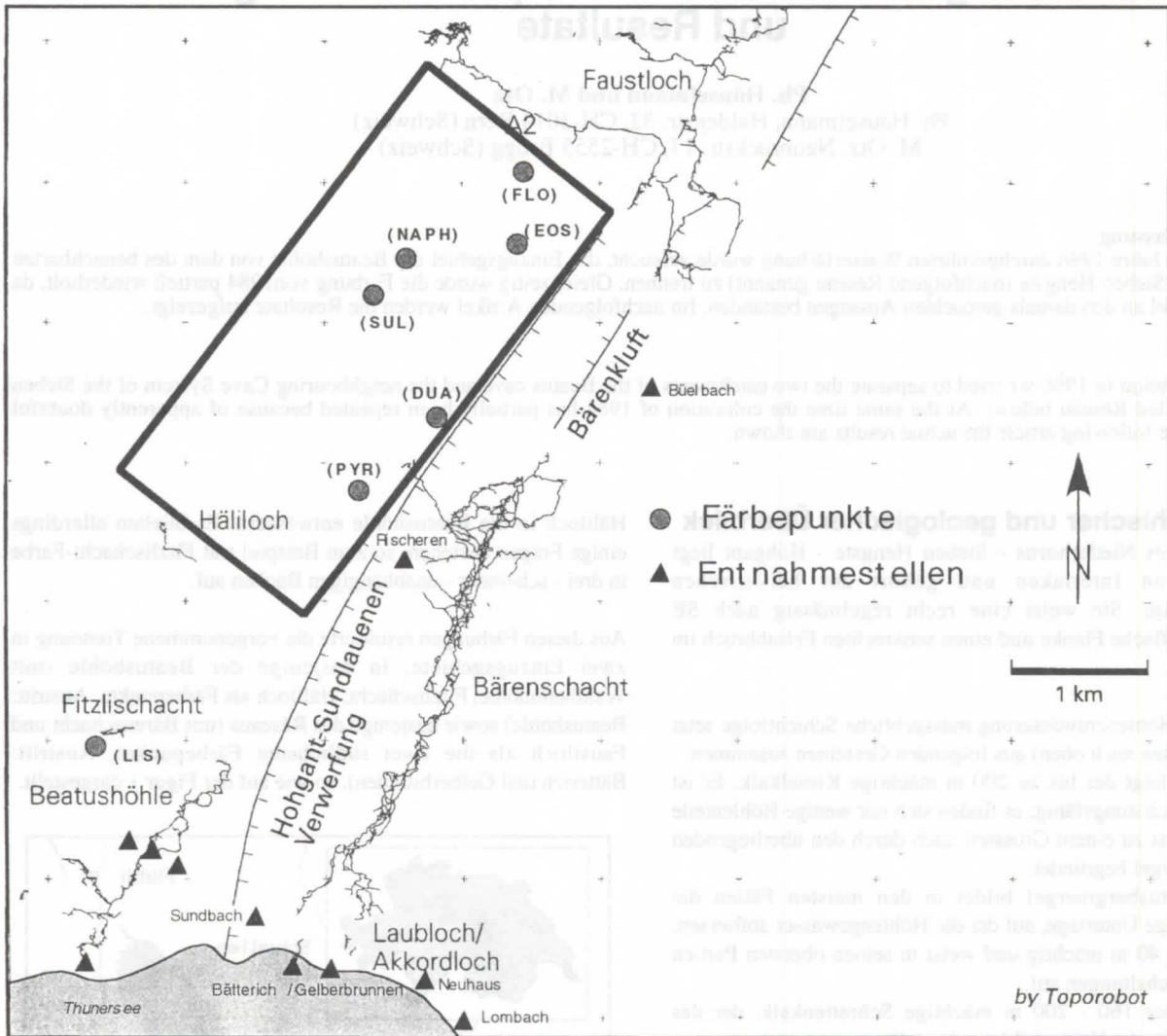

Figur 2: Plan der Region, Höhlen, Färbepunkte, Entnahmestellen

Die Färbung 1996

Dank der Unterstützung des Hydrologiebüros Otz in Bellmund bei Biel war es uns möglich, diese Färbung im Jahre 1996 zu realisieren. Nach mehreren Feldbegehungen entschieden wir uns für eine gleichzeitige Eingabe von sieben Farbstoffen (je 200 gr Lissamin, Pyranin, Eosin, Duasyne, Sulforhodamin, 1 kg Fluorescein und 2 kg Naphtionat) in die auf Figur 2 eingetragenen Färbepunkte. Die Färbung im Fitzlischacht wurde wegen der oben erläuterten Fragen wiederholt. Um möglichst alle Farbe zurückzuerhalten und die Fließsysteme möglichst genau zu erfassen, wurden an elf Stellen Proben gezogen, nämlich an fünf Stellen in der Beatushöhle, im Bätterich, im Bad Neuhaus sowie in den Oberflächenbächen Lombach, Büelbach, Sundbach und Rischerengraben.

Zur Organisation und technischen Durchführung der Färbung sei auf HÄUSELMANN (1997) verwiesen, da eine Aufzählung hier zu weit führen würde.

Bei der ersten Begehung und am Färbetag wurden bei den Quellen jeweils die Wassertemperatur und die elektrische Leitfähigkeit gemessen. Die letztgenannte Messung gibt den Gehalt an dissoziierten Ionen eines Fließgewässers wieder, sie ist temperaturabhängig. Die elektrische Leitfähigkeit kann wertvolle Informationen bezüglich der Wasserherkunft liefern.

Auswertung des Färbversuches

Perkin Elmer Filter-Fluorometer LS-2B: Das LS-2B hat auswechselbare Kantenfilter im Anregungsbereich und einen motorisch beweglichen Interferenzfilter (300-800nm) im Emissionsbereich. Eine mit linearer Frequenz gepulste Xenonentladungslampe dient als Lichtquelle. Der Fotomultiplier ist dabei die optische Verstärkerröhre. Anschliessend folgt elektronische Verstärkung mit digitaler Anzeige und Ausdruck auf Thermodrucker. Farbstoffe werden mit einer Empfindlichkeit von 10^{-6}g/m^3 Wasser nachgewiesen. In der Regel werden die Proben mit diesem Gerät seriell mit "festen Einstellungen" ausgemessen, z.B. für den Tracer Fluorescein wird eine Anregung von 480nm (Präzisions-Kantenfilter) und eine Emission von 515nm (Interferenzfilter) eingestellt etc.

Mit diesem Gerät wurden alle Proben untersucht. Proben mit hohen Peak-Werten wurden mit dem Doppel-Scanning-Verfahren mit dem Gerät "Shimadzu RF5001-PC" überprüft: Jeder Stoff hat eine charakteristische Anregung und Emission. Man fährt von tiefen Wellenlängen zu hohen, wobei der Wellenlängenunterschied zwischen Anregung und Emission konstant gehalten wird. Damit erscheinen die Emissions-Maxima der Tracer an bestimmten Stellen. Die Darstellung erfolgt im Konzentrations/Zeit-Diagramm.

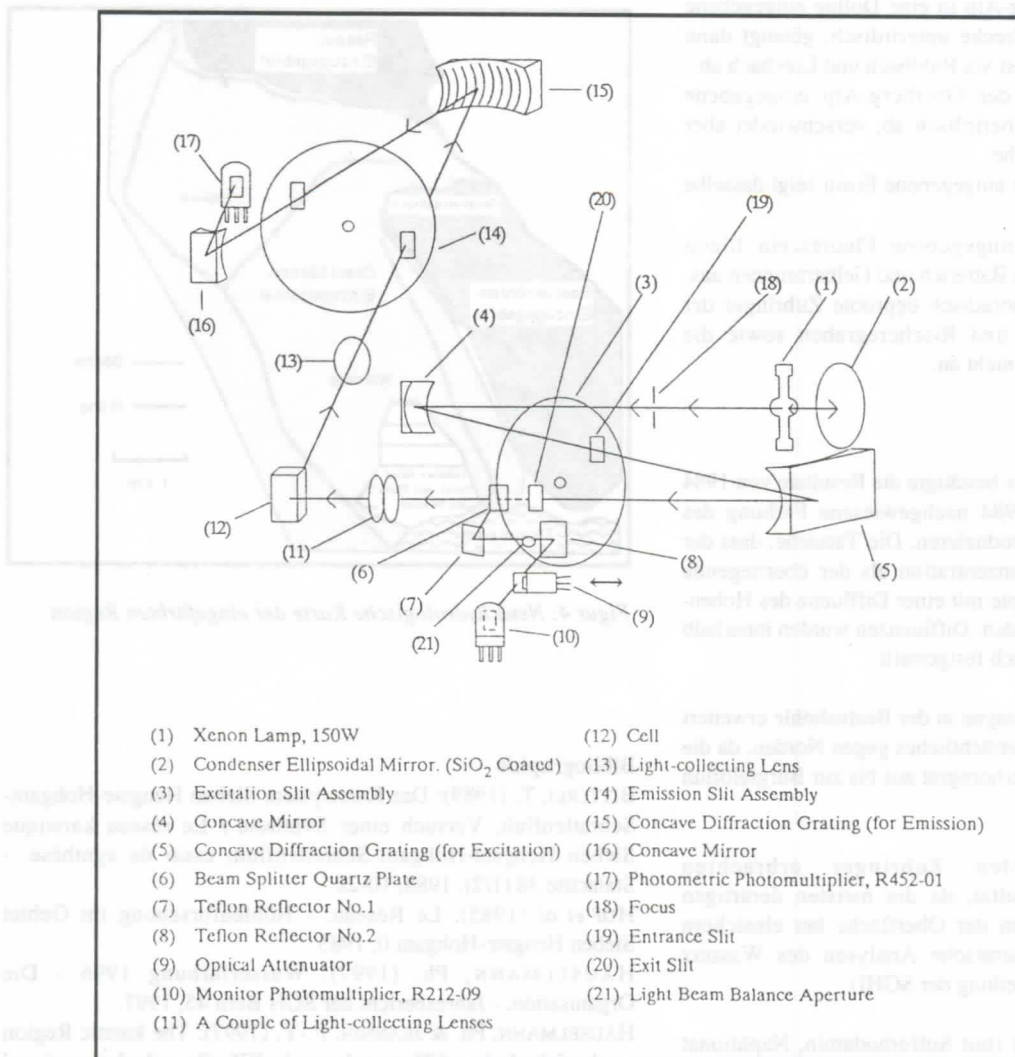

Figur 3: Shimadzu RF5001-PC. Die Funktionsweise und der Aufbau entspricht annähernd dem des LS-2B.

Quantitative Mengenbestimmungen: Zu den einzelnen Markierstoffen wurde mit dem LS-2B eine Eichkurve erstellt. Die ausgemessenen Werte um den Wert des "Grundrauschens" = Nullwert reduziert und in die entsprechenden Quantitäten umgerechnet.

Mit HPLC (High Pressure Liquid Chromatography) wurden letzte Unklarheiten beseitigt: Gegenüber dem Messverfahren mit Fluorometern (Kantenfilter- und Gittergeräten) und dem Doppelscanning (Shimadzu RF5001-PC) ist dies eine unterschiedliche Messmethode.

Es ist durchaus möglich, dass Huminsäuren und andere Fremdstoffe organischer Natur, evtl. sogar andere Tracer in hohen Konzentrationen, einen Farbstoff so maskieren, dass eine Fluoreszenzbestimmung, auch bei chemischer und physikalischer Vorbehandlung, verunmöglicht wird. Hier hilft nun HPLC. Einer Trägerflüssigkeit (mobile Phase) wird eine kleine Menge Probenwasser beigemischt und anschliessend mit hohem Druck durch eine Silicagelsäule (stationäre Phase) gepresst. Die eluierten Substanzen werden von der mobilen Phase in den Detektor transportiert und vom Schreiber als Gausskurven registriert.

Qualitativ: Die Retentionszeit ist bei gleichen chromatografischen Bedingungen stets gleich gross. Retentionszeit ist die Zeit, welche vom Einspritzen der Probe bis zum Erscheinen des

Signalmaximums auf dem Schreiber verstreicht. Die chromatografischen Bedingungen sind: Trennsäule, Zusammensetzung der mobilen Phase, Fließgeschwindigkeit der mobilen Phase, Probengröße und Temperatur. Zur Identifikation eines Peaks können wir daher die in Frage kommende Substanz rein einspritzen und die Retentionszeiten vergleichen.

Quantitativ: Die Fläche des Peaks ist der eingespritzten Stoffmenge proportional. Wenn wir verschiedene Lösungen genau bekannter Konzentrationen einspritzen, die zugehörigen Peakflächen bestimmen und eine Eichkurve zeichnen, können wir aus der Peakfläche einer unbekannt Probe deren Konzentration bestimmen.

Die Resultate

Wie erwartet wurde die Farbe des Fitzlischachtes (Lissamin) in der Beatushöhle wiedergefunden. Es zeigte sich, dass die übereinander liegenden Gänge Hoher Nordgang und Nordgang beide Farbe aufwiesen, der Hohe Nordgang aber etwa in fünffacher Konzentration.

Die oberhalb des Bärenschacht eingegebenen Farben Pyranin und Duasyne wurden ebenfalls in der Beatushöhle wiedergefunden.

Das in der Nähe der Oberberg-Alp in eine Doline eingegebene Sulforhodamin fließt eine Strecke unterirdisch, gelangt dann wieder ans Tageslicht und fließt via Bühlbach und Lombach ab. Das ebenfalls in der Nähe der Oberberg-Alp eingegebene Naphtionat fließt ebenfalls oberirdisch ab, verschwindet aber zuweilen unter der Erdoberfläche.

Das unterhalb der Alp Bäreney eingegebene Eosin zeigt dasselbe Verhalten.

Das bei der Alp Bäreney eingegebene Fluorescein fließt komplett ab und tritt wieder im Bätterich und Gelberbrunnen aus. Der Ostgang sowie einige sporadisch beprobte Zubringer der Beatushöhle, der Sundbach und Rischeregraben sowie die Karstquelle Neuhaus sprachen nicht an.

Interpretation

Die Färbung des Fitzlischachtes bestätigte die Resultate von 1984 nur teilweise. Speziell die 1984 nachgewiesene Färbung des Ostganges liess sich nicht reproduzieren. Die Tatsache, dass der Nordgang eine niedrigere Konzentration als der überliegende Hohe Nordgang aufweist, könnte mit einer Diffluenz des Hohen-Nordgang-Wassers erklärt werden. Diffluenzen wurden innerhalb der Beatushöhle bereits mehrfach festgestellt.

Der Fund von Pyranin und Duasyne in der Beatushöhle erweitert deren Einzugsgebiet um ein Beträchtliches gegen Norden, da die eingefärbten Bäche vom Niederhorngrat aus bis zur Burgfeldfluh oberflächlich abfließen.

Die sporadisch beprobten Zubringer erbrachten erwartungsgemäss kein Resultat, da die meisten derartigen Zubringer ziemlich direkt von der Oberfläche her einsickern dürften, was auch durch chemische Analysen des Wassers bestätigt wird (mündliche Mitteilung der SGHI)

Der darauffolgende Abschnitt (mit Sulforhodamin, Naphtionat und Eosin) entwässert vollkommen oberirdisch und stellt somit die eigentliche Grenze der Einzugsgebiete dar.

Die Tatsache, dass diese Bächlein zuweilen oberirdisch und dann wieder unterirdisch verlaufen, hat ihre Erklärung in der unterschiedlichen Verkarstungsfähigkeit der Hohgant sandstein-Lagen, die faziell sehr stark wechseln können.

Die Grenze gegen die Beatushöhle zu ist durch die Topographie gegeben (oberflächliches Einzugsgebiet entweder gegen die Burgfeldfluh oder gegen Oberberg). Die Grenze gegen das Réseau ist etwas unscharf, da in dieser Region der Lithothamnienkalk als Karstkörper fungiert und sich an der Basis desselben mehrere unterschiedliche Schwinden befinden können, die entweder gegen das Réseau oder gegen den Bühlbach zu entwässern können. Ab der Linie Bäreney - Gemmenalphorn-Nordflanke ist das Einzugsgebiet eindeutig das Réseau.

Die Quelle Neuhaus, an der Grenze zwischen der alluvialen Bödeli-Aufschüttung und dem Schratenkalk gelegen, wird aufgrund ihres Chemismus und Schüttungsverhaltens als Karstquelle gedeutet (mündliche Mitteilung der SGHI). Ein Zustrom von Grundwasser ist nicht auszuschliessen. Sicher ist nun jedenfalls, dass die Neuhaus-Quelle nicht mit dem Bätterich verbunden ist; es könnte sich hier um eine lokale Karstquelle handeln, die nur Wasser aus dem unmittelbar benachbarten Kalk bringt.

Als Synthese präsentiert sich die Karte der Einzugsgebiete so, wie auf Figur 4 dargestellt.

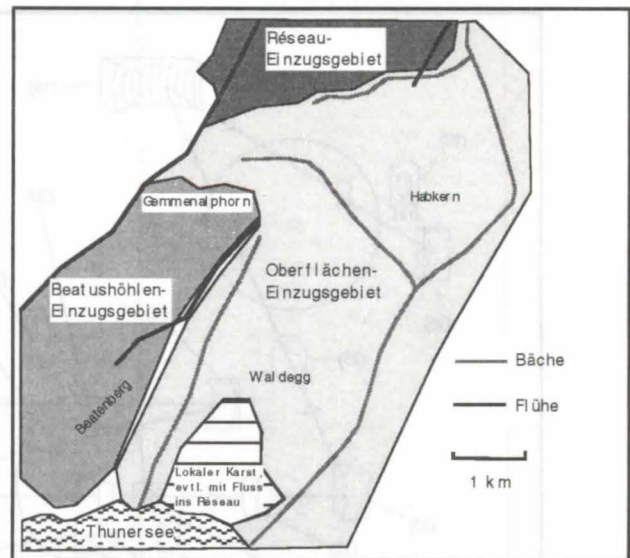

Figur 4: Neue hydrologische Karte der eingefärbten Region

Bibliographie

- BITTERLI, T. (1989): Das Karstsystem Sieben Hengste-Hohgant-Schrattenfluh, Versuch einer Synthese / Le réseau karstique Sieben Hengste-Hohgant-Schrattenfluh, essai de synthèse. - Stalactite 38 (1/2), 1988, 10-22
- HOF *et al* (1985): Le Réseau. - Höhlenforschung im Gebiet Sieben Hengste-Hohgant 0, 1985
- HÄUSELMANN, Ph. (1997): Wasserfärbung 1996 - Die Organisation. - Jahresbericht der SGH Bern 45, 1997.
- HÄUSELMANN, Ph. & JEANNIN, P.-Y. (1997): The karstic Region north of the Lake of Thun. - Actes du XIIe Congrès International de Spéléologie, La Chaux-de-Fonds
- KLÖTZLI, U. (1985): Wasserfärbung.- Jahresbericht der SGH Bern 33, 1985, 47-50
- WILDBERGER *et al* (1982): Markierversuche und weitere hydrologische Untersuchungen im Karst des Brienzgrates und des Brünigpasses. - Akten des 7. Nationalen Kongresses für Höhlenforschung, Schwyz.

Spéléologie, exploitation et protection des eaux souterraines dans les karsts des environs de Chambéry (Savoie-Isère, France)

Fabien Hobléa

CAGEP-URA 903 du CNRS, Institut de Géographie,
29 Avenue Robert Schuman, 13621, Aix-en-Provence Cédex, France.

Abstract

Several examples, located in Savoie (France), of speleologic actions concerning water management are given : water tracing, exploration and caves surveying etc... Applied aspects are just one of the multiple aims of such actions, which are also led to progress in the fundamental knowledge of the drainage, to guide speleological exploration and to teach covers the practice of scientific speleology. Covers proceed in association with karst scientists and local administration offices. That is the condition to obtain good results and to make these actions well agreed.

Résumé

Au travers d'exemples savoyards d'actions spéléologiques concernant la connaissance et la gestion des aquifères karstiques (participation à des traçages, exploration de cavités et fourniture ou réalisation de relevés topographiques en vue de captages ou d'établissement de périmètres de protection), sont examinées les conditions de réalisation garantissant à la fois des résultats exploitables et une bonne acceptation de ces opérations tant par les scientifiques que les aménageurs institutionnels, ce qui passe par la concertation et le partenariat entre les divers acteurs, mais aussi l'information et la formation des spéléologues.

1. Introduction : hydrogéologie et spéléologie

Aborder les rapports entre l'étude scientifique fondamentale et appliquée des aquifères karstiques et la spéléologie n'est pas un sujet nouveau. Suite à l'évolution des préoccupations en matière de gestion des ressources en eau, ce thème s'est trouvé revigoré au début des années 90, comme en témoigne le contenu des actes de congrès spéléologiques nationaux. A l'occasion du Congrès de Montpellier, organisé en 1991 autour d'un symposium sur "les eaux souterraines en milieu calcaire", pas moins de onze communications sur le thème furent ainsi présentées. Devant la multiplication des opérations sur les eaux karstiques impliquant des spéléologues, devant l'importance des enjeux, qui dépassent le plus souvent le cercle de la spéléologie, il a été jugé nécessaire de recenser et définir le rôle et la place des spéléologues dans la connaissance et la gestion des aquifères karstiques (AVIAS, 1991 ; BAKALOWICZ, 1994).

A partir d'exemples savoyards, répertoriés sur la figure 1, sont ici présentées quelques actions fondées sur une concertation entre spéléologues et spécialistes ou aménageurs, dans l'optique de concilier les intérêts de chacun.

Les spéléologues de la région chambérienne, à l'image de ceux d'autres départements karstiques (SAUVEL, 1991), ont été ces dernières années amenés à contribuer à plusieurs opérations de captage ou de protection des aquifères karstiques en Savoie et en Isère, soit dans le cadre de leurs activités propres, soit sur commande. Bon nombre d'entre elles s'inscrivent de plus localement dans le programme de recherche conventionnel entre Agence de l'Eau et structures spéléologiques fédérales, mis en place à la fin des années 80 (LAURENT, 1991).

2. Traçages réalisés par des spéléologues

L'opérations "Granier 94"

En juin 1994, le géosystème karstique du Mt Granier en Chartreuse, a fait l'objet d'un multitraçage répondant à trois objectifs complémentaires :

- * Faire progresser, dans le cadre d'une recherche universitaire doctorale, l'état des connaissances, encore fragmentaires, sur l'organisation et le degré de hiérarchisation des écoulements souterrains dans ce massif.

- * Former les spéléologues à la technique du multitraçage en couplant un stage scientifique fédéral (régional) à l'opération (HOBLEA, 1994).

- * Améliorer la connaissance de la vulnérabilité des circulations karstiques, d'une part dans le cadre de la collaboration instituée à l'échelon régional entre structures spéléologiques et Agence de l'Eau, d'autre part à la demande de l'hydrogéologue départemental agréé, dans le cadre du volet hydrogéologique de l'étude d'impacts du projet de ligne TGV Lyon-Turin (tunnel sous le Granier risquant d'affecter des sources soupçonnées d'être en relation avec le karst).

Dans le cadre du stage scientifique, les spéléologues ont participé à une partie de la préparation du traçage (analyse du contexte géologique, reconnaissance des sources, mise en place du dispositif de surveillance et préparation des traceurs). Ils ont effectué les injections dans l'endokarst en fin de fonte des neiges. Suivi de la restitution et analyses des prélèvements d'eau, demandant une disponibilité et des moyens spécifiques, ont en revanche été effectués par des universitaires, qui ont ensuite fait part des résultats aux stagiaires.

Des résultats qui intéressent aussi bien les explorateurs que les aménageurs : ce multitraçage a en effet permis de montrer l'unicité de l'émergence du massif en basses eaux, contrairement au schéma admis auparavant d'un compartimentage du massif en unités hydrogéologiquement indépendantes de part et d'autre de grands décrochements transverses. Les mesures de protection règlementaires du captage de Chapareillan pourront tenir compte de cette donnée nouvelle. De plus, les hydrogéologues de l'université de Savoie, chargés de l'étude d'impacts sur le tracé TGV, ont pu utiliser ce traçage, par le biais de réinfiltrations plus à l'aval de l'émergence dans les calcaires jurassiques sous-jacents, drainés vers des sources sensibles où le traceur est bien réapparu.

L'opération "Margérian 95"

Le second exemple récent est le traçage de mai 1995, réalisé par le Comité Départemental de Spéléologie de la Savoie dans la Tanne des Biolles (HOBLEA *et al.*, 1996). Cette cavité s'ouvre dans la montagne du Margérian au coeur du massif subalpin des Bauges. Elle se développe en suivant vers le nord-est le pendage des calcaires urgoniens, qui plongent vers un val contenant une importante zone noyée.

Le franchissement d'une trémie qui bloquait les explorations à - 50 m depuis 1985 a permis d'explorer à partir de 1993 le principal affluent souterrain du collecteur noyé de ce massif, suivi jusqu'à une nouvelle trémie à - 530 m. Le potentiel dépasse les 1000 m de dénivellée.

La "coloration" est destinée au départ à s'assurer de liaisons internes dans la cavité et de la rapidité du transfert jusqu'à la source vaclusienne du Pissieu, connue comme seule émergence du système. Mais là encore, des mobiles non spéléologiques viennent renforcer l'utilité de ce traçage : il se trouve en effet qu'une source captée sur l'autre versant de la montagne connaît des problèmes de pollution, qui coïncident avec des épandages de fertilisant (fumier) sur les pistes de ski du Margérian en cours de revégétalisation. Malgré un contexte géologique peu compatible avec l'idée d'une liaison, la DDASS de la Savoie s'est associée à la surveillance et au dépouillement du traçage afin de tester l'hypothèse d'un lien hydrogéologique entre l'impluvium du Margérian et ces sources captées. De plus, des travaux d'extraction de granulats dans le lit majeur du chéran, le principal cours d'eau des Bauges, qui passe à l'extrémité sud du Margérian, ont récemment libéré des écoulements (source dite du Villaret) dont les analyses indiquent une origine karstique. S'agit-il d'une ancienne exurgence colmatée par le remblaiement alluvial ? Tant les spéléologues que les scientifiques du karst comptent sur ce traçage pour apporter des éléments de réponse...

L'injection a lieu au plus fort de la fonte nivale à - 70 m, tandis qu'une équipe de pointe descendue au petit matin en basses eaux se laisse volontairement piéger dans le karst profond pour suivre le cheminement du colorant et observer le comportement du réseau en crue "limitée" (cycle journalier permettant une remontée en fin de nuit lors du regel extérieur).

Ce traçage révèle le caractère très direct et rapide de cet axe de drainage vers l'émergence, branché très à l'aval de la zone noyée, avec une vitesse maximale de circulation vers le Pissieu de l'ordre de 800 m / h (contre une vitesse de l'ordre de 300 m / h enregistrée précédemment en crue d'orage estival dans une cavité branchée plus à l'amont sur la zone noyée).

De plus, la source du Villaret a délivré une faible quantité de traceur à travers son placage alluvial, ce qui renforce l'hypothèse d'une ancienne exurgence (reste à s'assurer que la fluorescéine détectée ne provient pas d'infiltrations de la rivière de surface à l'aval du Pissieu via la terrasse alluviale...). Si cette hypothèse s'avère la bonne, un décolmatage artificiel par les carrières de granulats entraînerait un assèchement de la pittoresque émergence-cascade du Pissieu, but de promenade balisée et site naturel d'intérêt patrimonial majeur en Bauges...

Enfin, la surveillance des sources polluées sur l'autre versant de la montagne s'est révélée négative. Tout hydrogéologue sait qu'un tel résultat ne permet aucunement de trancher de manière péremptoire et définitive. Néanmoins, compte-tenu de la configuration structurale, il serait sage de rechercher les causes de pollution de ces sources ailleurs que sur l'impluvium du système du Pissieu...

3. Exploration, topographie et aide à la localisation de drains karstiques à capter ou protéger

Le forage AEP de La Féclaz en 1987

La station de ski de La Féclaz domine la ville de Chambéry sur le rebord occidental du massif des Bauges. Au milieu des années 80, un programme d'extension de la capacité d'hébergement de la station prévoyait un renforcement significatif de l'approvisionnement en eau par un forage direct dans un drain collecteur appartenant au réseau spéléologique reconnu sur plus de 20 km de développement sous la surface du plateau de La Féclaz (réseau Garde-Cavale).

Le projet a pris corps en 1987. Il a nécessité l'utilisation conjointe des données et techniques spéléologiques et des méthodes de pointe de repérage magnétostatique de cavités développées à l'époque par le LETI, laboratoire du Centre d'Etudes Nucléaires de Grenoble.

Sans entrer dans les détails de cette importante opération, largement exposés par ailleurs (FANTOLI, 1990 ; HOBLEA, 1990), soulignons le rôle tenu par les spéléologues, qui ont mis à disposition du maître d'œuvre les topographies détaillées du réseau souterrain dans lequel devait aboutir le forage. Il est clair que sans les découvertes spéléologiques et les documents en rendant compte, résultant de plusieurs décennies de patient labeur et d'un nombre d'heures incalculable passées sous terre ou devant la table à dessin (c'était avant Toporobot), ce forage de précision (cible de 5 m de large à travers 200 mètres d'épaisseur d'Urgonien) n'aurait guère été envisageable. De plus, des spéléologues locaux ont ensuite été employés par la société Hydrokarst pour assurer les travaux souterrains nécessaires au positionnement électromagnétique de la cible, puis à la construction d'une retenue d'eau souterraine, à plusieurs heures de progression de l'entrée du réseau la plus proche.

Exploration et étude d'une cavité hydrothermale accidentellement ouverte sur le chantier des nouveaux thermes à Aix-les-Bains.

Plus récemment, une autre opération lourde d'aménagement en terrain karstique a nécessité l'intervention des spéléologues savoyards, dans le contexte insolite (du moins en France) des circulations hydrothermales d'Aix-les-Bains.

Les travaux de terrassement préalables à la construction d'un nouvel établissement de cure ultramoderne ont démarré dès 1996, sur les terrains du parc de la villa Chevalley, accrochés au versant d'un anticlinal faillé d'urgonien enchassé dans la molasse (cette antiforme représente le contre-coup du chevauchement du front subalpin sur l'avant-pays savoyard). Le carreau de chantier est situé 200 m à l'amont des sources thermales intégrées à l'établissement actuel en centre-ville, une trentaine de mètres en contre-haut.

Comme l'étude d'impacts en prévoyait l'éventualité, les travaux de terrassement ont trépané une cavité aveugle, s'ouvrant par une verticale d'une dizaine de mètres, inexplorable sans équipement spéléo. Par souci de sécurité tant pour la poursuite du chantier que pour la qualité des eaux thermales, les responsables de l'aménagement ont donc fait appel au Comité Départemental de Spéléologie pour explorer et topographier la cavité, baptisée gouffre Chevalley.

Si ce dernier s'est avéré de taille modeste et inoffensif pour la stabilité du substrat, il a en revanche

permis d'atteindre la surface piézométrique de l'aquifère thermal. Vers la cote -27 m, la suite de cette cavité au développement essentiellement vertical est en effet ennoyée (cheminée d'équilibre). La température élevée de l'eau (42°C en moyenne) n'a permis qu'une prudente reconnaissance par le spéléonate Jean Bottazzi en décembre 96. Une courte plongée de 4 mn en volume étanche, lui a permis de progresser d'une quinzaine de mètres, avec une visibilité nulle, dans une diaclase plongeante, avant de buter sur un rétrécissement qui aurait nécessité un décapelé, bien risqué dans ces conditions...

Parallèlement à cette tentative de plongée, la surveillance du niveau du plan d'eau dans le gouffre lors d'un pompage à l'occasion du nettoyage annuel de la source thermique captée à l'aval, a permis de vérifier le lien direct entre l'eau visible dans la cavité et celle sortant à la source.

De plus, des prélèvements d'eau réalisés par les spéléos au fond du gouffre ont fait l'objet d'analyses bactériologiques de première importance pour l'étude des contaminations périodiques des eaux thermales constatées à la source. Avant la découverte du gouffre Chevalley, il n'était pas possible de trancher sur l'origine des germes indésirables. Ce regard sur l'amont de la circulation thermique a montré que des foyers de contamination peuvent exister avant la source dans ce type de cheminée d'équilibre.

Enfin, la reconnaissance de la configuration de la zone noyée par plongée et de son fonctionnement par surveillance du pompage permet d'envisager, sous réserve de traiter le problème de pollution épisodique, un captage direct de l'eau chaude à l'aplomb même du futur établissement thermal...

4. Des actions concertées à vocations multiples

Un partenariat entre spéléologues, scientifiques et aménageurs.

* Du côté des spéléologues, ces actions ne se sont pas réalisées à l'initiative de pratiquants isolés ou même de clubs mais au niveau départemental (Comité Départemental de Spéléologie de la Savoie), voire au niveau du Comité Spéléologique Régional Rhône-alpes et de l'Ecole Française de Spéléologie pour l'organisation du stage scientifique "Granier 94", qui a rassemblé autour des spéléologues savoyards une quinzaine de stagiaires de départements voisins.

* Toutes les actions citées ont fait l'objet d'un encadrement ou d'un soutien scientifique par un ou plusieurs chercheurs en spéléo-karstologie et / ou hydrogéologie karstique, mobilisant des membres du CAGEP-URA 903 du CNRS d'Aix-en-Provence (F. Hobléa et Ph. Audra), du Laboratoire de Géologie Structurale et Appliquée de l'Université de Savoie (G. Nicoud et M. Dzikowsky), du Laboratoire d'Hydrogéologie de l'Université d'Orléans (M. Lepiller) et de l'Equipe d'Hydrobiologie et d'Ecologie Souterraine de l'Université Lyon I (M.-J. Turquin et R. Laurent).

Chaque opération a fait l'objet de rapports et de notes, ainsi que d'articles et communications associant scientifiques et spéléologues, permettant à la communauté scientifique de juger de la validité des méthodes comme des résultats (HOBLEA *et al.*, 1996).

* Toutes les opérations mentionnées ont aussi associé en partenariat des aménageurs institutionnels : Agence de l'Eau (LAURENT, 1989), DDASS, DDAF, Société d'Aménagement de la Savoie, intervenus soit pour

le prêt du matériel technique (préleveurs automatiques...) ou le financement des traceurs, soit pour collecter et utiliser les résultats, transmis dans certains cas aux usagers concernés : collectivités locales (communes, districts, SIVOM etc...) ou organismes publics (Thermes Nationaux d'Aix-les-Bains). Ces usagers ont toujours été les premiers avertis des actions projetées, et ils ont été consultés sur leur opportunité.

Des actions polyvalentes.

Autre caractéristique commune aux exemples présentés, la polyvalence des objectifs et des centres d'intérêt :

* Orientation et progrès des investigations spéléologiques : si bon nombre de découvertes concernent des galeries "fossiles", déconnectées du drainage actuel, les investigations dans les drains actifs et noyés restent un axe de développement essentiel de l'exploration spéléologique.

* Amélioration des connaissances sur la structure et le fonctionnement du karst : les recherches hydro-spéléologiques peuvent apporter des données aux scientifiques du karst, qui étudient l'ensemble du système karstique, dont les réseaux souterrains sont une des composantes non négligeable. Les données seront exploitables à condition que les recherches soient réalisées dans les règles de l'art, ce qui suppose aujourd'hui pour les traçages de proscrire l'usage des seuls fluocapteurs à charbon actif pour surveiller la restitution, et donc de mettre en oeuvre des techniques non directement accessibles aux spéléologues. Une telle collaboration entre spéléologues et scientifiques peut ainsi déboucher sur des progrès décisifs en matière de karstologie, du moins sur le plan des connaissances des caractéristiques locales de tel ou tel système karstique :

- L'exemple du gouffre Chevalley est à ce propos édifiant, en livrant aux scientifiques une des rares cavités hydrothermales actives françaises, à laquelle seuls les spéléologues peuvent accéder. Notons au passage que, au vu des rapports soulignant l'intérêt scientifique de cette cavité, les Thermes Nationaux d'Aix-les-Bains ont décidé d'en préserver l'intégrité et d'en faciliter l'accès comme l'étude.

- L'exemple du multitraçage du Granier illustre également cet aspect : l'étude hydrogéologique des sources du massif avait conclu à la multiplicité de systèmes karstiques indépendants, là où un multitraçage dans l'endokarst a permis de montrer la hiérarchisation du drainage vers une émergence commune.

Finalement, l'idée est qu'avec un minimum d'encadrement et de méthode, les spéléologues peuvent contribuer efficacement à l'étude des circulations et du milieu karstiques. Cette efficacité dépend aussi grandement de l'effort de formation et d'information que les scientifiques sont prêts à fournir auprès des spéléologues intéressés.

* Formation des spéléologues aux approches scientifiques du karst : par le biais de stages scientifiques orientés vers l'hydrogéologie karstique en général et les traçages en particulier, à l'image du stage greffé sur l'opération "Granier 94", il ne s'agit pas de vouloir faire des spéléos des chercheurs de pointe au fait des derniers développements d'une science que seul un cursus académique complet permet de maîtriser, mais plutôt de véritables "équipiers scientifiques", sur le modèle des équipiers secours. Ces derniers, sans être des secouristes professionnels, n'en maîtrisent en effet pas moins les bases nécessaires à l'insertion dans une opération de secours souterrain, grâce à une formation adaptée et continue.

Pour une formation en spéléologie scientifique, nous pensons qu'il est préférable, à l'image de la plupart des stages de terrain universitaires, de travailler sur des opérations de recherche effectives, afin d'éviter de perturber inutilement le milieu par des exercices sans application (on imagine mal se mettre dans chaque région en quête de "karsts-école" à "sacrifier" pour la seule pédagogie).

Comme les stages de formation au secours souterrain, la formation d'équipiers scientifiques serait organisée par les structures spéléologiques fédérales, et encadrée dans ce cas par des scientifiques du karst patentés, fédérés ou non.

* Utilisation des données pour l'aménagement, l'exploitation et la protection de l'aquifère : tous les exemples cités ont débouché sur une insertion des résultats dans des études en cours : détermination de périmètres de protection (Granier), localisation de point de forage (La Féclaz), protection active de l'aquifère (thermes d'Aix).

À l'intérêt spéléologique se joignent ainsi à chaque fois un intérêt scientifique, pédagogique et utilitaire en termes de gestion des ressources en eau.

Des actions cependant limitées

L'exemple savoyard tend à montrer que des actions bien cadrées et bien encadrées, effectuées dans le karst profond pénétrable, peuvent satisfaire plusieurs objectifs, et mobiliser divers partenaires en permettant un groupement d'intérêts. Il ne faudrait toutefois pas en déduire que ce type d'actions peut s'appliquer dans toutes les situations et constitue la principale approche des ressources endokarstiques.

Ne serait-ce que sur le plan méthodologique, des limites apparaissent concernant l'idée même d'utilisation de l'endokarst comme point d'injection des traceurs. De même qu'il est illusoire de fonder la modélisation du fonctionnement des hydrosystèmes karstiques sur la seule étude des écoulements observés dans les réseaux spéléologiques (MANGIN & BAKALOWICZ, 1989), il est pour le moins délicat de vouloir extrapoler d'un traçage réalisé directement dans des drains collecteurs du karst profond les modalités de propagation d'un polluant qui a en réalité toutes les chances d'affecter l'aquifère karstique depuis la surface. Les simulations de propagation des polluants doivent donc être effectuées dans la mesure du possible depuis les points de diffusion potentiels en surface, sous peine de pertes d'informations capitales. Cette règle élémentaire pour l'hydrogéologue mérite d'être rappelée aux spéléologues.

Conclusion

Les actions savoyardes ont été menées dans le souci de produire un résultat rigoureux, en s'entourant des collaborations nécessaires, tant sur le plan scientifique qu'administratif. Ces opérations s'inscrivent ainsi en complément, et non en concurrence, des travaux hydrogéologiques menés depuis la surface.

Cette démarche doit permettre aux représentants décentralisés de la Fédération Française de Spéléologie de se positionner comme acteurs et interlocuteurs sérieux dans la gestion des ressources et du milieu karstique, et d'être associés, comme cela se fait en Savoie, aux procédures d'aménagement local, notamment lorsqu'il est question de réglementer l'accès à l'endokarst, dans le cadre par exemple de mesures de protection des aquifères.

Les données manquent à ce propos quant à l'impact réel de la fréquentation spéléologique sur la qualité des eaux souterraines, sujet d'étude qui reste à défricher par les hydrogéologues...

Références

- AVIAS, J. 1991. De l'importance de la spéléologie dans l'aménagement et la valorisation des ressources en eau des terrains karstiques. Les eaux souterraines en milieu calcaire. Actes XIXème Congrès National de Spéléologie. *Spelunca Mémoires* 19 : 135-144.
- BAKALOWICZ, M. 1994. La place des spéléologues dans la connaissance du karst. Journées Norbert Casteret, XXème Congrès FFS, 1992. *Spelunca Mémoires* 21 : 40-42.
- FANTOLI, J.L. 1990. Campagne de recherche magnétostatique par le LETI sur la localisation depuis la surface d'un repère en cavité karstique. XIXème Congrès régional Rhône-Alpes de Spéléologie, 6 p.
- HOBLEA, F. 1990. Les aménagements touristiques sur karsts d'altitude : problèmes et impacts. Mém. D.E.A. Géographie, Univ. Lumière-Lyon 2, 234 p.
- HOBLEA, F. 1994. Le stage scientifique régional "Granier 94". Actes Quatrième Rencontre d'Octobre. SCParis : 69-81.
- HOBLEA, F. DODELIN, Ch. LASSERRE, D. BOTTAZZI, J. MANIEZ, P. 1996. La tanne des Biolles : un axe de drainage majeur sous le massif du Margériaz (Bauges, Savoie, France). *Karstologia* 27 : 41-56.
- LAURENT, R. 1989. La Fédération Française de Spéléologie, interlocuteur privilégié des agences de l'eau. *Spelunca* 35 : 85-86.
- LAURENT, R. 1991. Travaux et réponses que peuvent apporter les spéléologues aux collectivités locales. Les eaux souterraines en milieu calcaire. Actes XIXème Congrès National de Spéléologie. *Spelunca Mémoires* 19 : 153-160.
- MANGIN, A. & BAKALOWICZ, M. 1989. Orientations de la recherche scientifique sur le milieu karstique. Influences et aspects perceptibles en matière de protection. *Spelunca* 35 : 71-79.
- SAUVEL, C. 1991. Quelques exemples de collaboration entre hydrogéologues et spéléologues dans le département de l'Hérault. Les eaux souterraines en milieu calcaire. Actes XIXème Congrès National de Spéléologie. *Spelunca Mémoires* 19 : 149-152.

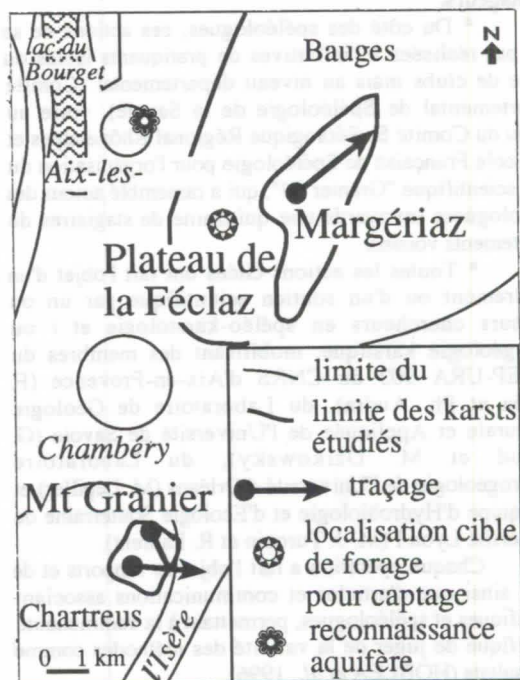

Figure 1. Quelques opérations spéléologiques récentes concernant la protection et la mise en valeur des aquifères karstiques en Savoie (1987-1997).

Délimitation du bassin versant karstique de la Bienne (Haut-Jura, France) par la géologie et les essais de traçage

par Robert Le Pennec

Association Spéléologique de Saint-Claude, 11, rue du Belvédère, F - 39200 SAINT-CLAUDE

Abstract :

The Bienne is a left bank tributary of the river Ain, whose upper topographical watershed is including a significant number of closed basins and watercourses or lakes leakages. Since the last 30 years, a 72 tracing tests have been performed and enabled us to appreciate the actual size of the karst area which is feeding the upper valley of the torrent. While replacing these tracing tests in the structural framework of the folded Upper Jura, it is possible to divide this area into 14 hydrogeological units. The largest of them, the Grandvaux synclinorium, is more than 30 km long and is including the longest underground flow in the Franche-Comté, originating in the Chaumusse sinkhole and the Enragé spring.

Résumé :

La Bienne est un affluent de la rive gauche de l'Ain, dont le haut bassin versant topographique comporte de nombreux bassins fermés et des pertes de cours d'eau ou d'émissaires de lacs. Depuis plus de 30 ans, 72 essais de traçage ont permis d'apprécier l'étendue réelle de la zone karstique alimentant la haute vallée du torrent. Replacés dans le contexte structural du Haut-Jura plissé, ces traçages permettent une subdivision en 14 unités hydrogéologiques. La plus grande d'entre-elles, le synclinorium du Grandvaux, fait plus de 30 km de long et inclut la plus longue circulation souterraine de Franche-Comté, entre la perte de la Chaumusse et la source de l'Enragé.

1. Bassin versant topographique

Vers le Nord (fig. 1), le bassin de la Bienne est séparé de celui de l'Orbe par le village des Rousses et le mont Risoux. Vers l'Ouest, le secteur des Crozets est drainé de manière aérienne vers la Bienne, mais le bassin du Grandvaux est fermé autour du lac de l'Abbaye. Le ruisseau d'Heria se jette dans la Bienne à Jeurre, mais le lac d'Antre est situé dans un bassin fermé. La limite ouest, avec le bassin de l'Ain, est donc difficile à percevoir. Vers l'Est, les reliefs des Molunes et Bellecombe séparent la Bienne de la Valsérine. Au Sud, la limite topographique passe entre Oyonnax et Viry. Enclavée dans ce secteur, la dépression du lac de Lamoura n'a pas d'exutoire aérien. Ce grand secteur ainsi défini présente donc un nombre important de zones problématiques.

2. Structure

Le Haut-Jura (fig. 1 et 2) est une succession de plis complexes d'orientation générale NE-SW. Les anticlinaux de Jurassique supérieur ou moyen chevauchent généralement vers l'Ouest des synclinaux à cœur crétacé et tertiaire, souvent empâtés de dépôts glaciaires. L'ensemble des plis est tronçonné par deux grands accidents transverses : celui de Morez et celui de Saint-Claude, et les plis sont affectés transversalement par deux abaissements axiaux : celui de Morez qui fait chuter les axes de 200 m et celui du Flumen (de 400 m). La haute vallée de la Bienne traverse en cluse les reliefs du Haut-Jura : cluses de Morez, de Vaux-les-Saint-Claude, de Jeurre et de Dortan-Lavancia, mais elle suit un axe synclinal entre Morez et Saint-Claude. Les séries calcaires atteignent 1200 m d'épaisseur, et la Bienne les entaille sur 800 m, dans des gorges sauvages.

3. Traçages et détermination des limites

Ensemble du bassin :

Les sources karstiques sont situées au sommet des différents niveaux marneux, les plus importantes étant à la base du Séquanien. Plusieurs sources vaclusiennes ont un conduit terminal de plus de 50 m de profondeur : Bief Noir, 85 m; Doye Gabet, 77 m; Bief Goudard, 60 m; Brive, 56 m. D'autres émergences peuvent être masquées sous les dépôts glaciaires, surtout vers Lavancia où le réseau des Bracelettes est très peu connu.

Les traçages effectués dans le Haut-Jura (fig. 1) montrent une tendance générale au drainage dans l'axe des plis : le secteur des Lacs de Bellefontaine et des Mortes résurge à la source de la Doye Gabet sur l'abaissement axial de Morez, la

région comprise entre le secteur de Lamoura et la Pesse sur les émergences de celui du Flumen (MUDRY & ROSENTHAL, 1977). A partir des différents essais de treçage, des cours d'eau principaux et de la structure (sommets d'anticlinaux dans le sens longitudinal, zones d'élévation axiale des plis dans le sens transversal), on peut subdiviser le Haut-Jura en quatorze unités à drainage karstique (fig. 1) :

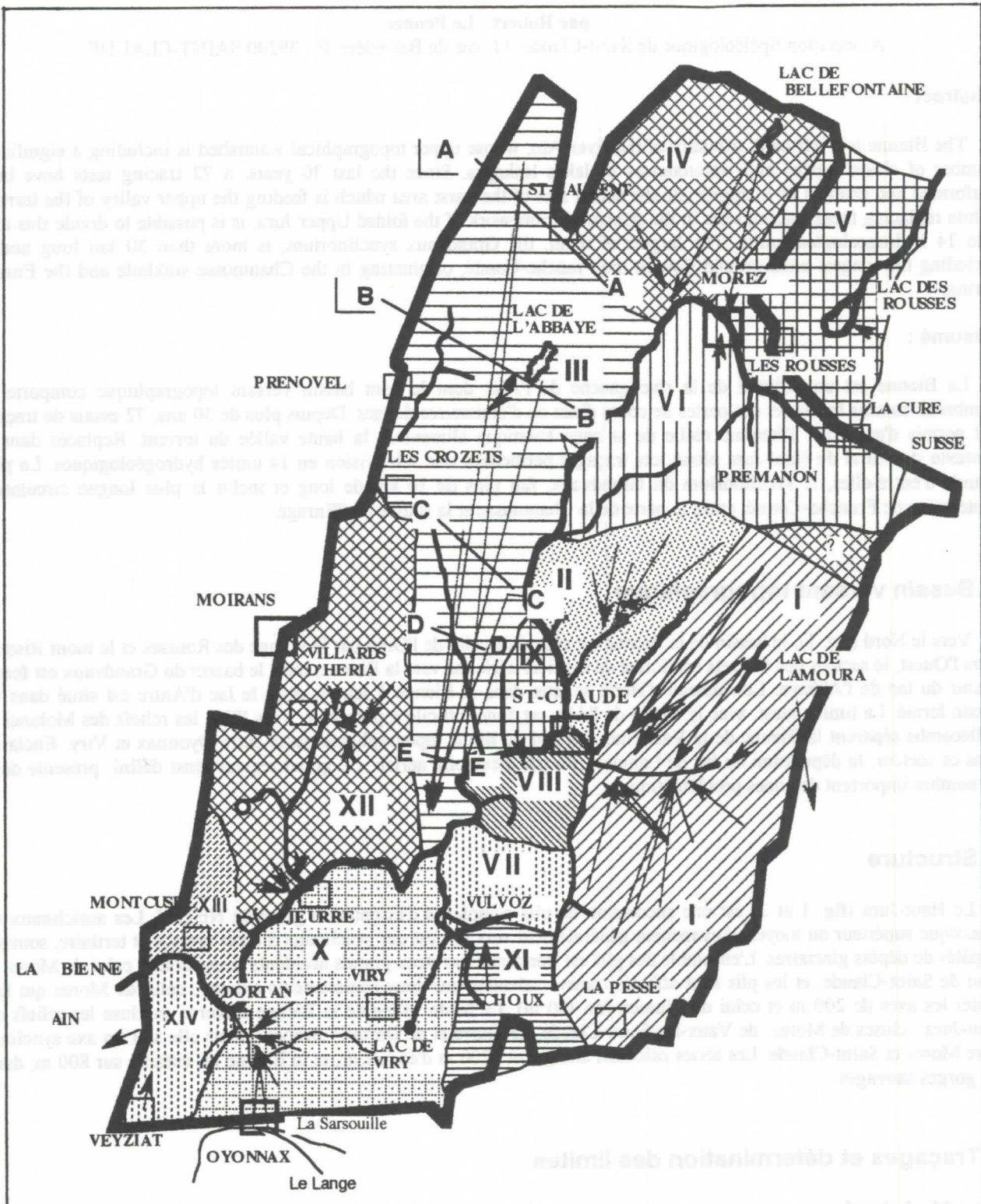

A-A : Tracé des coupes de la figure 2

Fig. 1 : Les 14 zones hydrogéologiques du Haut-Jura et le bassin versant de la Bienne.

I : Lamoura - la Pesse	II : Longchaumoisi - Cinquétral
III : Grandvaux	IV : Bellefontaine - Morez - Forêt Mt-Noir
V : Risoux - lac des Rousses	VI : Jouvencelles - Longchaumoisi - la Mouille
VII : Vulvoz	VIII : crêt du Surmontant - Ranchette - Mt Chabot
IX : forêt d'Avignon	X : Viry - Oyonnax
XI : Choux	XII : Jeurre - lac d'Antre
XIII : Montcusel - Chancia	XIV : Veyziat - Uffel

Synclinorium du Grandvaux :

Les quatre zones majeures de drainage karstique du Haut-Jura sont le système de la Doye Gabet à Morez, le secteur de Lamoura-la Pesse, le système d'Oyonnax -Viry et le Grandvaux. Le synclinorium du Grandvaux est une zone relativement plane de 900 à 1000 m d'altitude. Les sources situées dans la vallée de la Bienne s'étagent entre 510 et 350 m. Un premier long traçage effectué depuis la perte du lac de l'Abbaye (FRACHON, 1965; MUGNIER & CHATELAIN, 1969) est réapparu à la source de l'Enragé. La source de l'Enragé qui est située dans la cour de l'usine Breuil à Chassal, a comme trop-plein la grotte de l'Enragé.

En 1994, 30 kg de fluorescéine ont été injectés au gouffre de la Tane à la Chaumusse (LE PENNEC, 1987 a et b), dans le but de délimiter l'unité en direction de l'accident de Morez. 25 jours plus tard, le traceur atteignait la résurgence de Brive (27 km), et le lendemain la source de l'Enragé (distance : 29,5 km, vitesse apparente : 47,2 m/h). L'eau a été tracée pendant 3 jours, mais non visible à l'oeil nu.

Cette relation souterraine, la plus longue de Franche-Comté, a montré une faible vitesse de circulation, comparativement aux autres traçages du Haut-Jura qui ont circulé à 100 m/h en moyenne.

Le Grandvaux est un synclinorium large au niveau de Saint-Laurent, où sont situées les pertes de (fig. 2, coupe AA). Il se rétrécit au niveau de Leschères (fig. 2, coupe DD) où il doit être chevauché par l'anticlinal du bois de Cuttura. La zone de sortie se situe donc dans le coeur d'un anticlinal pour l'Enragé (fig. 2, coupe EE), sur le flanc ESaint pour Brive, sur la rive gauche de la Bienne, à la faveur des écaillés du Trunet. Cette unité hydrogéologique va donc de l'accident de Morez au Nord à celui de Vuache-Molinges au Sud, sans qu'on puisse savoir si ces failles jouent un rôle de limite.

4. Conclusion

L'utilisation combinée du traçage artificiel et de l'étude structurale du Haut-Jura permet la délimitation de 14 unités hydrogéologiques dans le bassin versant de la Bienne. Le drainage karstique se fait principalement dans la direction d'allongement des plis, polarisé par les grandes structures transversales : accident et zone d'abaissement axial de Morez, accident de Saint-Claude et zone d'abaissement axial du Flumen, accident de Vuache-Molinges.

Le synclinorium du Grandvaux apparaît ainsi comme une grande structure triangulaire de plus de 30 km de longueur, de 100 km² de surface, à drainage exclusif vers la vallée de la Bienne

Références

- ALABOUVETTE B. 1965 : Etude géologique de la région de Saint-Laurent (Jura). Thèse 3^e cycle Géologie, Besançon, 117 p., 14 pl HT.
- AUBERT D. 1965 : Calotte glaciaire et morphologie jurassienne. Ecl. Geol. Helv., vol. 58, 1, 555-578, 9 fig.
- BADIN L. & MAYA C. 1971 : Etude des circulations souterraines par fluorimétrie. SRAE Franche-Comté, 35 p., 10 fig., inédit.
- B.R.G.M. Cartes géologiques 1/ 50 000^e : Moirans-en-Montagne, Morez, Saint-Claude.
- CHAUVE P., DUBREUCQ F., FRACHON J.C., GAUTHIER A., METTETAL J.P. & PEGUENET J. 1987 : Atlas des circulations souterraines reconnues par traçage en Franche-Comté. 35 p., 9 fig., 17 pl. Ann. Scientif. Univ. Besançon, Géologie, Mém. H.S. n° 2.
- FRACHON J.C. 1965 : Le réseau de l'Enragé (Jura français) : une percée hydrogéologique de 21 km. Le Boueux, bull. trimest. de la Section de Genève de la Soc. Suisse de Spéléol., III, 4, 5-10.
- I.G.N. Cartes topographiques : 1/ 100 000^e Annecy-Lausanne ; 1/ 25 000^e : Morez et Saint-Claude.
- LE PENNEC R. 1987 : Inventaire des colorations. Assoc. Spéléol. de Saint-Claude, Bull. Spécial n° 3, 74 p.
- LE PENNEC R. 1987 : Inventaire des colorations du Parc Naturel Régional du Haut-Jura. Actes 8^e Congrès Nat. Soc. Suisse de Spéléol., 125-134.
- MUDRY J. & ROSENTHAL P. 1977 : La Haute-Chaîne du Jura entre Morez, Saint-Claude et la Pesse. Thèse 3^e cycle Géologie Besançon, 205 p., 95 fig.
- MUGNIER C. & CHATELAIN D. 1969 : Les recherches hydrogéologiques sur la percée karstique lac de l'Abbaye - résurgences de l'Enragé (21 km) et la récente coloration du Spéléo-Club Salinois (Jura). Ann. Spéléol. CNRS, t. 24, 2, 299-316, 2 fig.

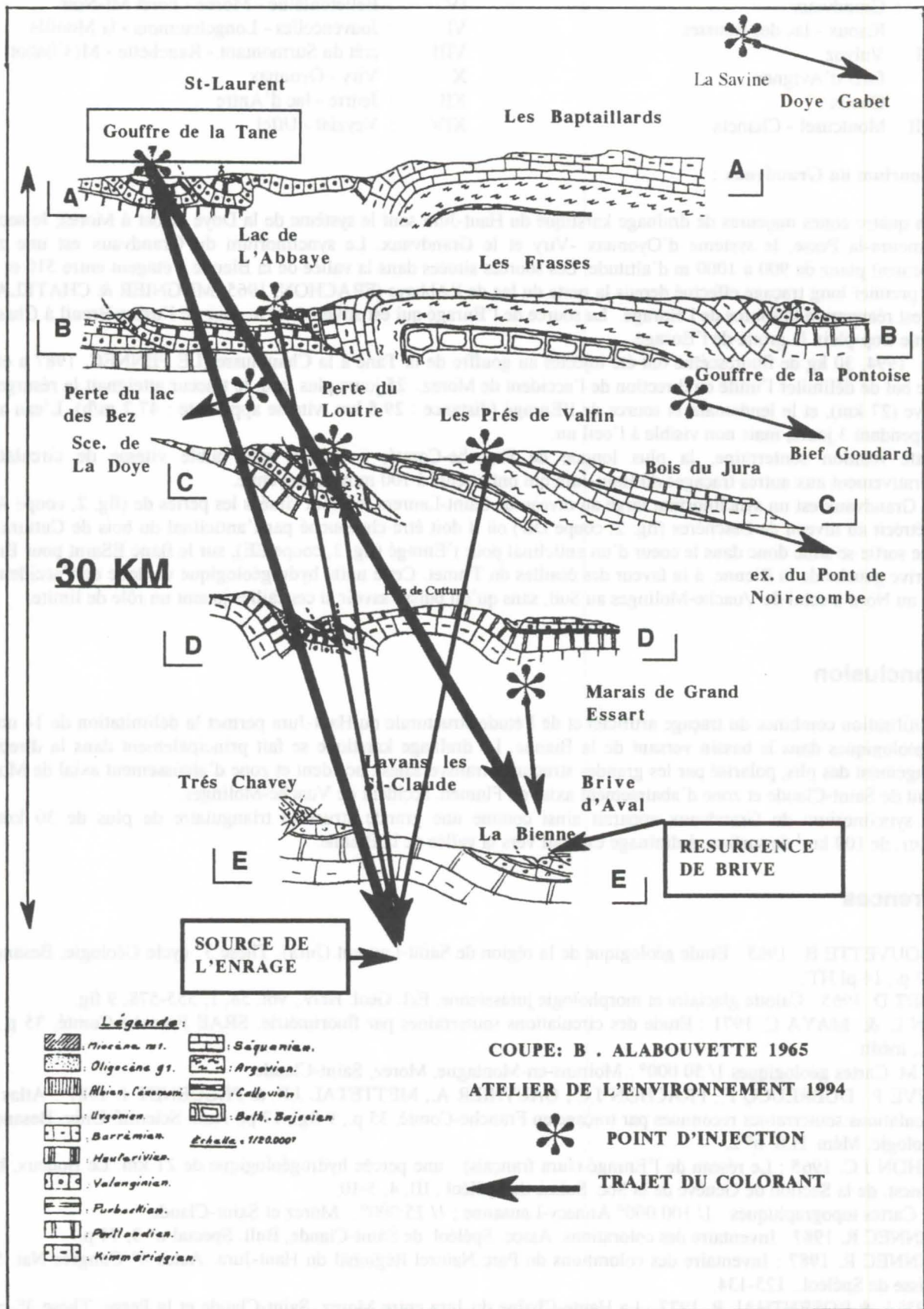

Fig. 2 : Coupes géologiques et traçages dans le synclinorium du Grandvaux (Unité III)

Contrôle automatique de plusieurs paramètres dans la Grotte des Merveilles (Aracena, SW de l'Espagne)

W. Martín-Rosales, M. López-Chicano, A. Pulido-Bosch et A. Vallejos

Groupe de Recherche "Ressources Hydriques et Géologie de l'Environnement". Université de Grenade. Espagne

Abstract

Within Cave of the Marvels, the air humidity, temperature and variations in the piezometric level of an interior lake were continually monitored; these parameters were all related to the number of visitors to the cave, a tourist attraction, and their influence on the environment. The continual measurements of CO₂ levels were halted after a few days because of problems with the sensors. A comparison of the results obtained from a chamber that is relatively distant from the tourist route with those from visited areas provides an estimate of the influence of visitors and of the illumination, which emits both heat and light, thus stimulating the development of algae and other micro organisms. The existing adverse conditions of humidity, CO₂ and temperature have led to the alteration of numerous speleothemes. An electron microscope study has shown the alterations produced in the crystals.

Résumé

La Grotte des Merveilles fait l'objet d'un suivi continu de l'humidité de l'air, de la température de l'air, de l'évolution du niveau piézométrique mesuré dans un lac intérieur, le tout en rapport avec le nombre de visiteurs à la grotte aménagée au tourisme et son influence sur l'environnement. Les mesures continues de CO₂ ont dû être arrêtées après quelques jours étant donné les problèmes de l'appareillage. L'humidité, la température et les précipitations sont aussi mesurées à l'extérieur de la cavité. La comparaison des résultats obtenus dans une salle éloignée du parcours touristique et ceux obtenus dans les lieux visités permet d'estimer l'influence des visiteurs, ainsi que du système d'éclairage qui apporte de la chaleur et de la lumière, favorisant le développement d'algues et d'autres microorganismes. Les conditions adverses atteintes dans l'humidité, le CO₂ et la température ont favorisé l'altération de plusieurs spéléothèmes, dont le contraste peut être fait avec les secteurs non visités qui restent inaltérés. Une étude par microscope électronique a permis de vérifier les altérations induites dans les cristaux.

Introduction

La Grotte des Merveilles est une des nombreuses cavités karstiques espagnoles aménagées pour le tourisme. Elle est située dans le village d'Aracena, au nord-est de la province de Huelva et à 70 km de la frontière hispano-portugaise (figure 1). Bien que sa découverte date du siècle dernier, elle ne fut ouverte au public qu'en 1911; plus de 160.000 personnes par an la

visitent actuellement. Creusée dans un petit affleurement de marbres du Cambrien inférieur sur lequel s'est établi le noyau urbain d'Aracena, elle a une longueur totale connue de 2130 m; elle est constituée essentiellement par trois niveaux superposés; les deux inférieurs sont aménagés pour le parcours touristique, d'une longueur d'environ 1.000 m; le troisième -plus élevé- est inaccessible au public, et montre une beauté spectaculaire de grande variété et richesse de concrétions. Le développement probable en profondeur n'est pas connu étant donné, entre autres raisons, que la cavité est inondée dans son niveau plus inférieur.



Figure 1.- Situation géographique d'Aracena, où se trouve la Grotte des Merveilles.

L'exploitation intensive du complexe souterrain à des fins touristiques a eu des répercussions négatives sur l'environnement naturel, similaires à celles décrites dans d'autres cavités du monde (FERNÁNDEZ *et al.*, 1986; ANDRIEUX, 1988; CIGNA, 1993; MANGIN & D'HULST, 1995). Les autorités municipales, conscientes des problèmes d'environnement, demandèrent en 1993 la réalisation d'une étude détaillée pour l'identification des principaux impacts, le degré d'altération actuelle et l'élaboration d'une série de mesures protectrices et correctrices face à ces affections. Les premiers résultats de cette étude ont révélé l'existence de secteurs où l'altération des concrétions devenait plus importante (MARTÍN ROSALES *et al.*, 1994), coïncidant avec des zones de dimensions réduites et ventilation déficiente; il a aussi détecté une grande abondance d'algues, liée à un réseau dense de projecteurs de lumière artificielle à grande énergie calorifique.

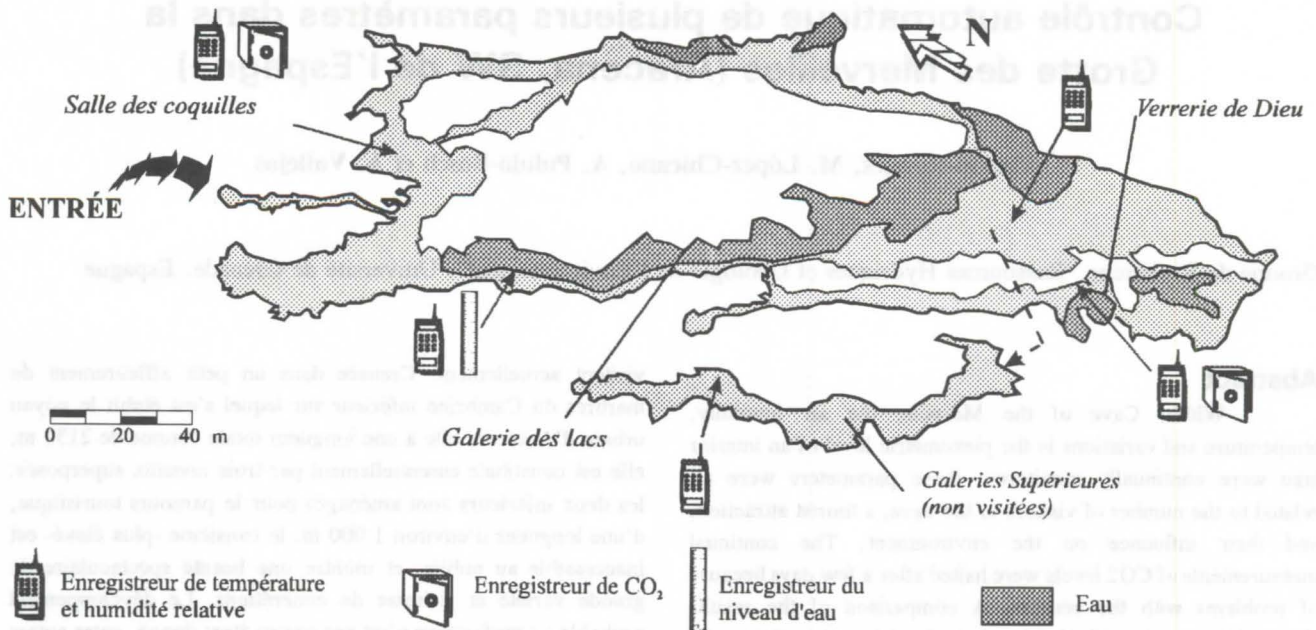

Figure 2.- Schéma de la cavité et du réseau d'observation de paramètres. Base topographique élaborée par le Grupo de Exploraciones Subterráneas (GES) de la Sociedad Excursionista de Malaga (SEM).

Le réseau d'observation

Le réseau de contrôle et suivi de paramètres du milieu comprenait à l'origine cinq senseurs pour mesurer la température et l'humidité de l'air à un intervalle de 15 minutes. Plus tard, furent enregistrés le contenu en CO₂ de l'air et l'évolution du niveau piézométrique dans les lacs, au moyen de deux *data logger* (figure 2).

Les valeurs élevées d'humidité relative qui se présentent habituellement dans la plus grande partie de la cavité -presque 100 %- rendirent inutiles les équipements d'enregistrement du CO₂ atmosphérique peu de mois après leur mise en fonctionnement.



Figura 3.- Enregistrements continus de température de l'air et entrée de visiteurs dans la Verrerie de Dieu et les Galeries Supérieures, correspondant au mois d'août 1994 et août 1995.

Parallèlement ont été enregistrés de façon automatique la température et l'humidité relative de l'air, ainsi que les précipitations, tout cela à l'extérieur de la cavité. De plus, on a réalisé de nombreux profils avec des instruments portatifs tout au long de la grotte, dans lesquels on a mesuré l'humidité relative, la température et la vitesse de l'air. Étant donné qu'il était nécessaire de comparer les paramètres mesurés avec ceux des secteurs non influencés par l'homme, on a installé des appareils au troisième niveau de karstification, bien éloigné du parcours touristique.

L'air est l'un des milieux où les affections ont lieu de façon plus immédiate après l'entrée des visiteurs, comme le montre la figure 3. On y présente les deux enregistrements continus de température, correspondant aux *Galeries Supérieures* -non visitées- et à la salle appelée *Verrerie de Dieu*. Cette dernière salle présente de nombreuses concrétions pariétales, au toit et au sol, formées par des cristaux d'aragonite, excentriques, gours et formes globulaires; dans cette salle, la température peut augmenter de près d'un degré après l'entrée d'un groupe de visiteurs. L'affection la plus remarquable se produit au mois d'août, le nombre de visiteurs étant plus important, ainsi que le contraste thermique intérieur-extérieur.

Cet effet thermique est, dans une certaine mesure, cumulatif pour de courtes périodes, en fonction de la distance à l'entrée de la Grotte; on a également constaté l'effet thermorégulateur des lacs, dont les eaux atténuent la fluctuation thermique à leurs alentours (PULIDO-BOSCH *et al.*, 1997). L'augmentation de la température s'accompagne d'une diminution de l'humidité du milieu qui peut être réduite de 3 %. Le système actuel d'éclairage a un effet identique à celui des visiteurs, puisqu'il provoque l'augmentation de la température -en raison de la grande énergie libérée- et la diminution de l'humidité relative.

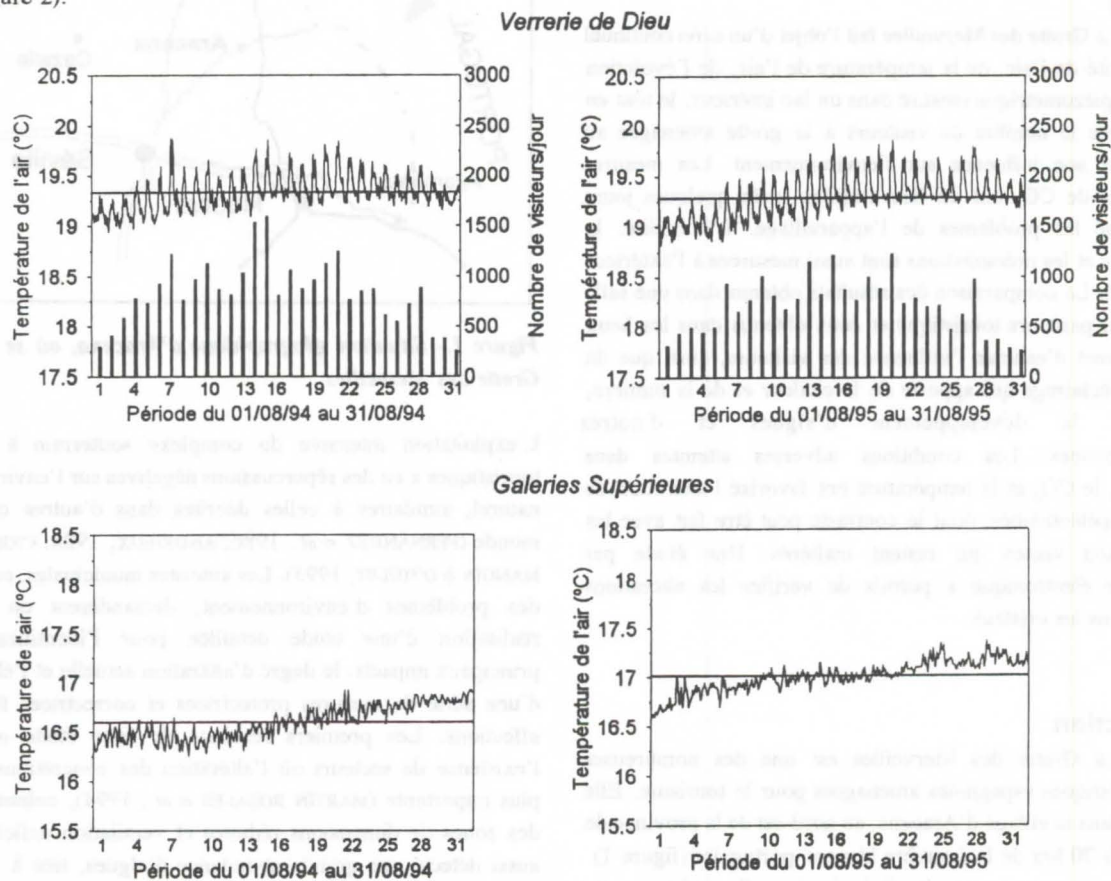
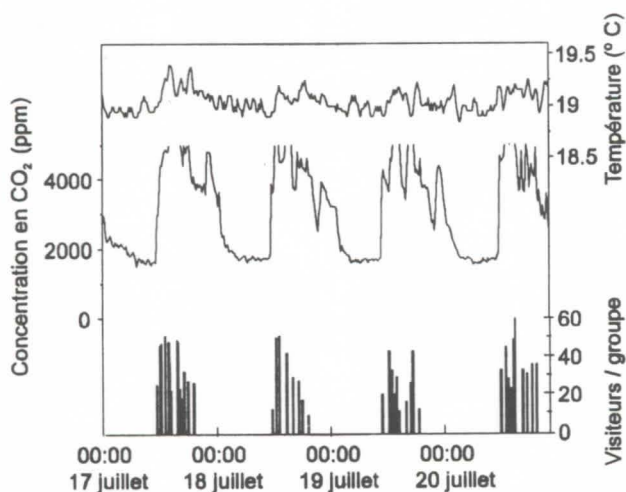

Figure 4.- Concentration en CO₂ de l'air, température de l'air et nombre de visiteurs par groupe dans la Verrerie de Dieu.

La concentration en CO₂ est habituellement, de façon naturelle, plus élevée dans les cavités qu'à l'extérieur (EK & GEWELT, 1985), étant donné la ventilation plus faible et l'apport de CO₂ à partir du sol et de la zone radiculaire; on a pu constater cette affirmation dans cette cavité, où la concentration proche à l'entrée est de 600 ppm (zone la plus ventilée), et atteint 1500 ppm dans les secteurs plus éloignés. Le passage des visiteurs fait monter les concentrations à 5000 ppm (figure 4). On constate en

partie une origine biologique non humaine, due probablement à la respiration végétale, pour quelques pointes de CO₂ enregistrées durant la nuit, après la fermeture de la cavité au public. Une augmentation aussi considérable de la pression partielle de CO₂ dans la cavité a un impact sur le milieu, étant donné qu'il s'agit d'une atmosphère beaucoup plus agressive, en ce qui concerne la roche encaissante et donc les spéléothèmes.

L'attraction principale de la *Galerie des Lacs* est l'existence de grandes masses d'eau qui ont été ornementées de nombreuses lampes submergées. Le niveau atteint par l'eau coïncide avec le niveau phréatique de l'aquifère lié à l'affleurement carbonaté où se développe la Grotte; cet aquifère est alimenté essentiellement par l'eau de pluie, la précipitation moyenne étant d'environ 900 mm/an (MARTÍN-ROSALES *et al.*, 1994). L'extrême sécheresse de la période 1993/1995 et l'existence d'un forage proche qui pompe 7 l.s⁻¹ ont contribué à faire baisser sensiblement le niveau de l'eau, même au-dessous de la position des lampes.

Les concrétions manifestent des altérations visibles étroitement liées aux impacts déjà indiqués. En effet, le changement des paramètres du milieu -augmentation de CO₂ et température, diminution de l'humidité, grande quantité d'énergie lumineuse- et le transport vers l'intérieur de la cavité de spores et de microorganismes dans les chaussures et les vêtements des visiteurs ont provoqué la prolifération d'algues, lichens et champignons, spécialement abondants aux alentours des points d'éclairage. Ces microorganismes altèrent les spéléothèmes de façon aussi bien mécanique que chimique, comme le suggère VILES (1987). L'étude comparée de 25 échantillons par Microscope Électronique de Balayage ("Scanner") a permis de détecter l'existence de corrosions multiples dans les cristaux qui, si les mesures adéquates ne sont pas prises, pourraient détériorer de manière irréversible de grandes étendues de la cavité (PULIDO-BOSCH *et al.*, 1997).

Considérations finales

Les effets dérivés des visites touristiques à la cavité et de l'infrastructure mise au point dans ce but, sont visibles dans l'air -augmentation de la température de l'air et du contenu en CO₂, et diminution de l'humidité du milieu-, dans l'eau -baisse du niveau piézométrique-, et dans la roche. Dans celle-ci, les impacts se manifestent par le développement d'algues, champignons et lichens qui trouvent un milieu favorable dû à l'énergie calorifique fournie par les systèmes d'éclairage.

Suite à l'étude réalisée on a proposé différentes mesures correctrices en vue de réduire la dégradation de la cavité (MARTÍN-ROSALES *et al.*, 1996); parmi ces mesures on peut souligner la diminution du nombre de visiteurs par groupe et de la fréquence d'entrée de ceux-ci, le remplacement progressif du système classique d'éclairage par un autre constitué par les "lumières froides", plus coûteux mais de meilleur rendement et de moindre impact; la paralysation des pompes dans le forage proche de la cavité; traitement des niveaux plus colonisés par la microflore avec une solution désinfectante non agressive à la roche; et le maintien d'un réseau d'observation de paramètres de l'environnement, et de suivi de la récupération du milieu.

Remerciements

Nous remercions la Mairie d'Aracena, pour les facilités données pour la réalisation des études, ainsi que les géologues Isabel Gómez, Rosario Herrera y Antonio Arriaza; à la CICYT, projet AMB95-0493.

Bibliographie

- ANDRIEUX, C. 1988. Influence de l'homme sur l'environnement climatique souterrain. *Actes des Journées Félix Trombe*, Moulis, Vol. I: 96-122.
- CIGNA, A. 1993. Environmental management of tourist caves: the examples of Grotta di Castellana and Grotta Grande del Vento, Italy. *Env. Geol.*, 21: 173-180.
- EK, C. & GEWELT, M. 1985. Carbon dioxide in cave atmospheres. New results in Belgium and comparison with some others countries. *Earth surface processes and landforms*, 10: 173-187.
- FERNÁNDEZ, P.L., GUTIÉRREZ, I., QUINDÓS, L.S., SOTO, J. & VILLAR, E. 1986. Natural ventilation of the Paintings Room in the Altamira Cave. *Nature*, 321: 586-588.

MANGIN, A. & D'HULST, D. 1995. Fréquentation des grottes touristiques et conservation. Méthode d'approche pour en étudier les effets et proposer une réglementation. *Simposio Internazionale Grotte Turistiche e Monitoraggio Ambientale*, Italia: 117-145.

MARTÍN ROSALES, W., RODRÍGUEZ NAVARRO, C.M., LÓPEZ CHICANO, M., PULIDO BOSCH, A. & VALLEJOS, A. 1994. Análisis de la influencia antrópica sobre la Gruta de las Maravillas de Aracena (España). In (J.R. Fagundo, A. Pulido Bosch, J.E. Rodríguez Eds). *El Karst y los acuíferos kársticos. Ejemplos y métodos de estudio*. Cuba: 279-290.

MARTÍN ROSALES, W., PULIDO BOSCH, A., LÓPEZ CHICANO, M., RODRÍGUEZ NAVARRO, C.M. & VALLEJOS, A. 1996. Principales impactos antrópicos en la Gruta de las Maravillas (Aracena, Huelva). *Geogaceta*, 20 (5): 1162-1164.

PULIDO BOSCH, A., MARTÍN ROSALES, W., LÓPEZ CHICANO, M., RODRÍGUEZ NAVARRO, C.M. & VALLEJOS, A. 1997. Human impacts in a tourist karstic cave (Aracena, Spain). *Env. Geol.* (sous presse).

VILES, H. 1987. A quantitative scanning electron microscope study of evidence for lichen weathering of limestone. Mendip Hills, Somerset. *Earth surface processes and landforms*, 12: 467-473.



Figura 4.- Concentración en CO₂ de las respiraciones de los miembros de visitas por grupos en la Gruta de las Maravillas.

An inexpensive flow-through field fluorometer

by Pierre-André Schnegg¹ and Nathalie Doerfliger²

¹ Groupe de géomagnétisme de l'Université, Rue de l'Observatoire 58, CH-2000 Neuchâtel, Suisse

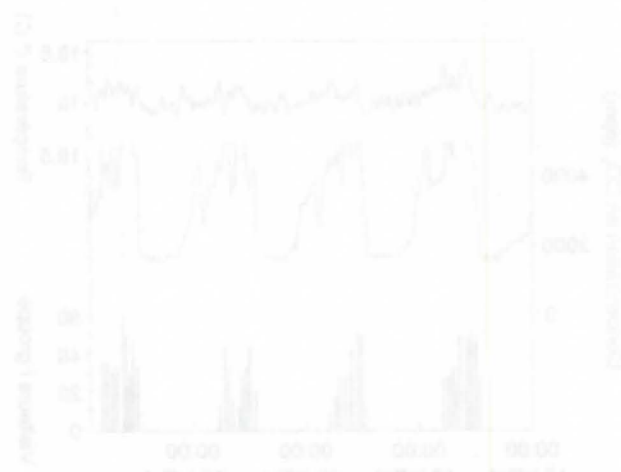
² Centre d'hydrogéologie de l'Université, Rue Emile-Argand 11, CH-2007 Neuchâtel, Suisse

Abstract

In order to simplify sampling dye tracers in water streams without having to invest money in expensive systems, we developed a highly sensitive flow-through field fluorometer. This apparatus was tested successfully in the field with fluorescein and sulforhodamine. A submersible probe is connected to a digital data logger and the data is written to a PCMCIA memory card allowing 2 weeks of unattended recording at 1 sample every 4 minutes. A sensitivity as low as 0.05 ppb has been achieved. Simultaneous concentration measurements of 2 tracers is possible, at the expense of reduced sensitivity, however.

Résumé

Dans le but de faciliter et d'automatiser la mesure *in situ* de la concentration de divers traceurs fluorescents, nous avons développé un fluorimètre de terrain dont la sensibilité avoisine celle d'un appareil de laboratoire. Ce fluorimètre a été testé avec succès lors de traçages à l'uranine et à la sulforhodamine. La sonde submersible est reliée à un boîtier d'acquisition et les données sont écrites sur une carte PCMCIA permettant deux semaines d'enregistrement à raison d'une mesure toutes les 4 minutes. Le niveau de sensibilité est de 0.05 ppb. La séparation de 2 traceurs simultanés est possible, moyennant une diminution de la sensibilité.

1. Introduction

The design of a new flow-through field fluorometer, able to be put in a stream or a spring to measure small dye concentrations was initiated at the request of researchers at our university. Similar equipment is already commercially available but at a cost prohibitive to academic grants. We designed an automatic, inexpensive device, with the idea of replacing a mechanical sampling system. The advantage of our system is that it replaces the sampler in most situations, provided there is no need to keep the water samples for further analyses. Although it was initially designed for uranine (fluorescein) dye tracer, we also tested it with sulforhodamine, and with a mixture of both.

2. Description of the fluorometer

The apparatus is made up of two parts, a data acquisition box and a waterproof, metallic cylinder which contains the optical system. A 15 metre cable, with waterproof connectors links the 2 parts. Set-up of the fluorometer is possible in most of the conditions found at the water's edge (Photo 1).

The fluorometer

The optical system used for the fluorescence excitation and detection is a standard one: The light emitted by a lamp is filtered to select only the wavelengths corresponding to the excitation band of the dye. The light is then focused on a transparent tube through the middle of which the water flows freely (Fig. 1). The natural waterstream is sufficient to insure an almost instantaneous movement of the fluid across the optical system, with whatever orientation the fluorometer has relative to the stream. The tube is bent at both ends to prevent daylight from entering.

The fluorescence from the dye is collected at a lens on the photodetector. Excitation light residuals, which always occur in spite of different excitation and

emission axes, are removed by another filter. The photodetector current is amplified within the sensor box. The output signal is fed to the datalogger through the cable. Tests done with calibrated concentrations have a linearity and reproducibility that are close to 1%.

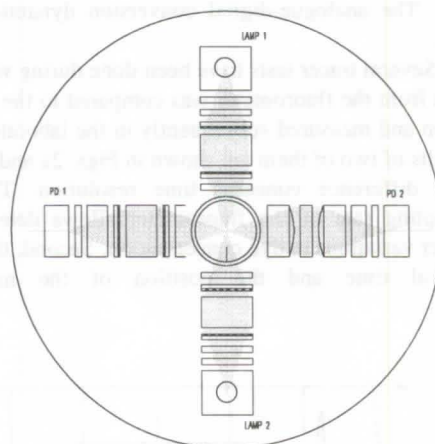

Fig. 1 : Fluorometer optical system with 2 perpendicular excitation and detection axes. Water flows perpendicularly in the central tube.

Practical experience indicates that it is often necessary to measure the water turbidity, since it can considerably alter the measurement in the following ways:

- 1) by reducing the excitation light and fluorescence through absorption by suspended particles.
- 2) scattering of excitation light toward the detector.

To measure the turbidity, we mounted a second detection axis in which the emission filter was replaced by an excitation filter. In clean water, even in the

presence of dye, the signal of this axis is very small. It corresponds to natural scattering of water. The presence of suspended particles scatters light in all directions, giving rise to a signal proportional to the turbidity.

In water tracing experiments, it is often interesting to use two dyes simultaneously. In order to separate their fluorescence signals, we installed a second excitation axis, identical to the first, but with a different filter. The new filter is designed to favor the excitation of the second dye at the expense of the first. Thus, 4 independent values can be sampled by combining the two light sources and the two photodetectors.

Data acquisition

The datalogger box contains the acquisition electronics and a battery. Every 4 minutes, a 2-second measurement cycle is initiated. The lamps are successively switched on and off. Six values are collected: the 4 discussed above, and the values at zero excitation (this measure gives the photodetector baseline). All the information is written to a PCMCIA memory card. This data medium can be easily and safely read in a portable computer. Battery and memory card capacities allow for 2 weeks of unattended data recording.

3. Performance

The detection threshold of the fluorometer (used in the real situation of a quiet stream) is 5×10^{-11} g/ml for uranine. Sensitivity is 200 mV for a concentration of 10^{-7} g/ml. In clean water, the residual noise level is 0.1 mV. The analogue-digital conversion dynamics is 16 bits.

Several tracer tests have been done during which the data from the fluorometer was compared to the samples taken and measured subsequently in the laboratory. The results of two of them are shown in Figs. 2a and 2b. The first difference concerns time resolution. The high sampling rate of the fluorometer allows detection of faster variations in dye concentration. Second, the tracer arrival time and the position of the maximum

concentration reach an accuracy of as short as 4 minutes.

A summary of the properties of the sampler and the fluorometer is given in the Table 1.

Advantages of the field fluorometer compared to samples measured subsequently in the laboratory

The autonomy of operation, the readings every 4 minutes and not having to visit the site are the principal advantages of the field fluorometer. In the case of the mechanical sampler, however, the bottles filled with the water samples must typically be handled at the site at the end of each series. This operation is always error prone and there is a risk of contamination even if the greatest care is taken. Then, the samples must be analysed by bringing them about to a laboratory, which costs more and has inevitable delay. Moreover, the storage of the samples prior to analysis can lead to variations in the dye concentration. Also, in the case of tracer tests using several dyes, chemical cross-reaction can occur. It is also been documented that sulforhodamine G is adsorbed by clay in an hour (MDAGHRI ALAOU, 1992).

Two advantages of the fluorometer relate to mechanical aspects: unlike the water sampler, the fluorometer has no moving parts, and therefore no wear. Also, because it is always completely submerged, freezing cannot prevent water from flowing through the system window.

Measuring fluorescence is done on the flowing water. The flow may have particles particularly during a fast rise in water level. Water turbidity then becomes an influencing component of the dye concentration measurement. This is never the case with laboratory analyses, where care can be taken to allow the water to settle before analysis. Up to some threshold, the turbidity effect can be removed from the signal, since one of the photodetectors is permanently measuring it. The sensitivity threshold is directly related to water clarity. Therefore, laboratory measurement will detect a smaller dye concentration compared to *in situ* field fluorometer measurements.

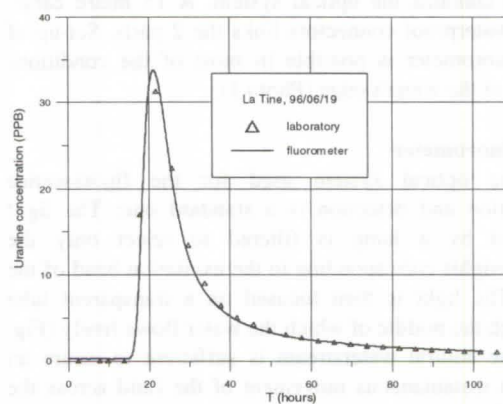
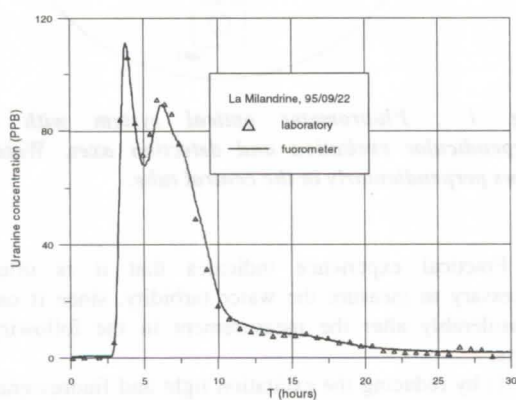

Fig. 2 a & b: Comparison of the results from the fluorometer (line) and the sampler (triangles) at 2 sites.

	Sampler	Fluorometer
Time resolution	bottle filling time	2 seconds
Field duration	number of bottles x sampling period	2 weeks
Work expense	large: many visits necessary	low: set-up and removal
Subsequent handling	sample analysis in the laboratory	none
Result availability	up to several days	immediate
Error by contamination	possible	impossible
Errors by tracer degradation	possible	impossible
Moving parts (wear)	yes	none
Freezing sensitivity	yes	no

Turbidity sensitivity	none if samples filtered	yes
Saturation threshold	none	1.25×10^{-6} g/ml
Usable tracers	all, incl. biological	dyes
Number of simultaneous tracers	>2	2
Detection threshold (uranine)	2×10^{-11} g/ml	5×10^{-11} g/ml

Table 1 : Comparison of a water sampler and field fluorometer performance. Disadvantages are shaded.

Disadvantages

The maximum detection level of the fluorometer is determined by the amplifier gain. In a tracer test, this gain is kept fixed. However, it can be decreased before the test, if it is desirable to measure larger concentrations.

Using a water sampler allows analysis for all tracers, including the biological ones (JEANNIN *et al.*, 1995). Furthermore, the separation of simultaneously injected tracers (dyes and others) is a straightforward task using samplers. The fluorometer works well with one dye tracer at a time but also can separate uranine and sulforhodamine values.

Simultaneous use of 2 tracers

To be able to separate 2 tracers, the fluorometer must be calibrated. The coefficients c_{11} , c_{12} correspond to a signal under excitation by source 1 of the uranine and sulforhodamine at a concentration of 10^{-7} g/ml, whereas c_{21} , c_{22} corresponds to source 2. The expressions

$$[u] = \frac{c_{22}x_1 - c_{12}x_2}{c_{11}c_{22} - c_{12}c_{21}} \quad [s] = \frac{c_{11}x_2 - c_{21}x_1}{c_{11}c_{22} - c_{12}c_{21}}$$

give the concentration of uranine (u) and sulforhodamine (s). The values x_1 , x_2 are the voltages measured on the photodetectors.

Note that careful choice of excitation and detection filters is important to ensure a good separation of the tracers. Combinations that result in too small values of the denominator must be avoided. However, the same filter set can be used for various combinations of dye tracers, as long as the denominator rule is observed. Laboratory tests show that it is possible to separate 2 tracers with good accuracy, provided their individual response is known (Fig. 3).

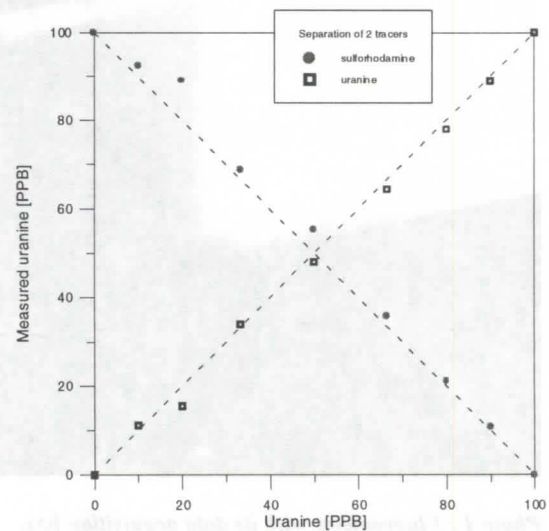

Fig. 3: Separation of 2 tracers. Determination of their concentration in the mixture. The real uranine concentration is on the horizontal axis (inverted scale for sulforhodamine) and measured concentration on the vertical axis.

Conclusion

The flow-through field fluorometer represents an economical alternative to commercial fluorometers and to mechanical sampling systems. Compared to the latter, it has the advantage of dramatically reduced surveillance and maintenance (one set-up and one removal). Its short time resolution should allow an new approach to hydrogeological issues that were neglected with the use of samplers.

The data availability is immediate. If needed, the content of the memory card can be read into a laptop computer at any moment, and the tracer test still carried on. Laboratory delays and expenses are not needed. Simultaneous use of several tracers is current practice. To develop further this instrumentation, an effort should

still be made to optimise the excitation/detection filter sets. In addition, the advent of laser diodes in the green part of the spectrum will allow new sources for the selective excitation of uranine.

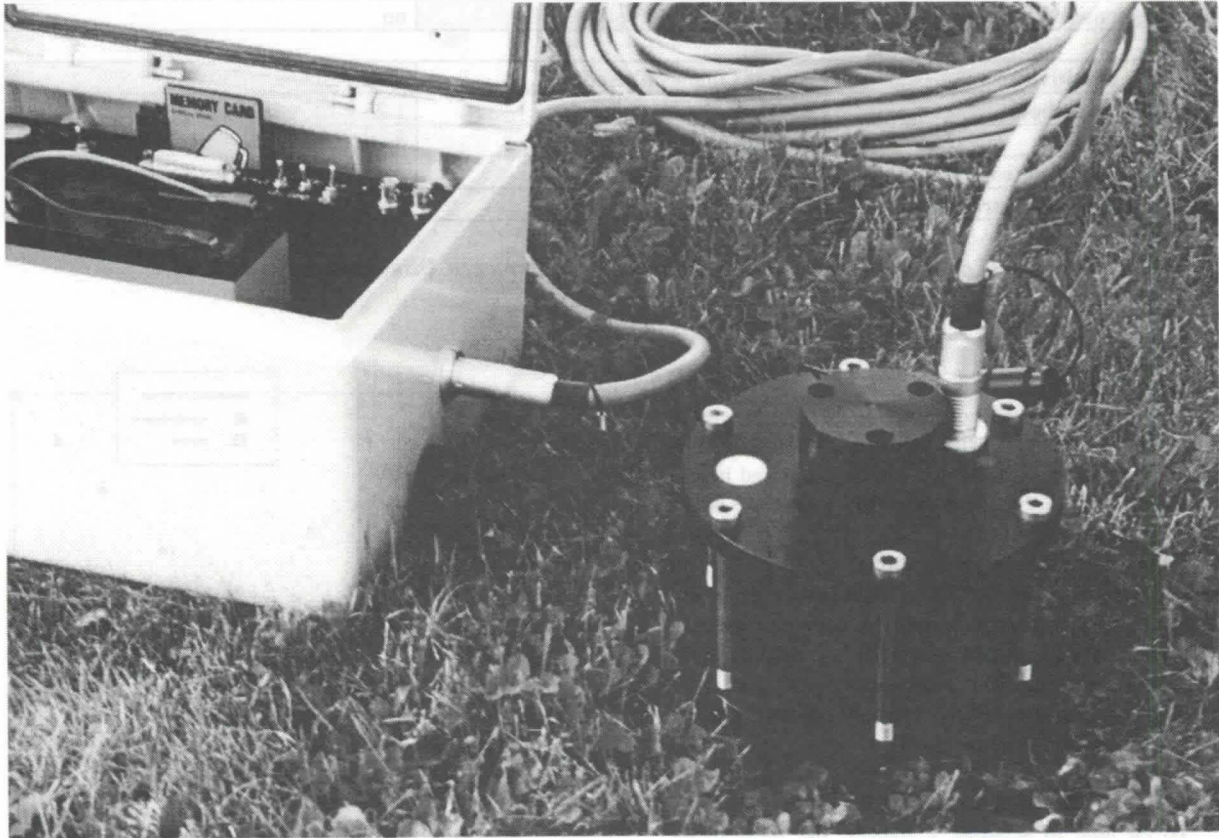

Photo 1 : Fluorometer with its data acquisition box.

References

JEANNIN, P.-Y., A. WILDBERGER & P. ROSSI. 1995. Multitracing-Versuche 1992 und 1993 im Karstgebiet der Silberer (Muotatal und Kloental, Zentralschweiz). *Beitraege zur Hydrogeologie*, Graz, 46: 43-88.

MDAGHRI ALAOU, A. 1992. Traceurs artificiels en hydrogéologie: Limites d'application et critiques des méthodes d'analyses. In: *Hydrogéologie des milieux discontinus sous climats arides*, Marrakech, Maroc.

Experimental design, technique and protocol in fluorometric tracing of ground water

by Chris C. Smart & L. Zabo

Department of Geography, University of Western Ontario, London, Ontario, N6A 5C2, Canada. SMART@SSCL.UWO.CA

Abstract

Detector-spectrofluorometer and water-filter fluorometry provide two complementary tools in tracer testing. Current practice largely relies on the former technique, despite some limitations in quality assurance. A set of technical enhancements have been undertaken on the Turner Designs Model 10 Series filter fluorometer to redress this imbalance by improving efficiency. In addition, improvements in protocol are suggested. A preliminary framework for optimal design of tracer tests is presented. Nevertheless, there remain barriers to wider deployment of filter fluorometers, notably in complex traces and borehole tests.

1. Introduction

The majority of ground water traces in Anglo-America are used for determining ground water trajectories in karst aquifers (QUINLAN 1986) and employ fluorescent dyes collected on activated charcoal detectors, extracted using an alkaline-alkali elutant, and analysed on a spectrofluorometer. The technique is extremely cost-effective in tackling basic questions of "hydrogeography", where many sampling sites are under assessment. Moreover, spectrofluorometry permits relatively precise separation of tracers so that multi-tracing can be undertaken, i.e. several tracers can be used simultaneously.

The charcoal-spectrofluorometer approach has become widely established and accepted in hydrogeological disputes. However, there are some disadvantages to the charcoal-spectrofluorometer technique which deserve consideration. Detectors can be contaminated in handling and processing. Only minute quantities of dye concentrate are needed to contaminate parts per trillion (ppb) samples. Replicate tracing is ambiguous, because residual dye may well cause an apparent positive analysis. Furthermore, the integrated nature of the fluorescence measurement provides limited proof against contamination; a given signal may just as easily arise from contamination as reception of the true tracer. A related shortcoming is the lack of quantitative information on time, concentration and mass. The processes of tracer adsorption, exchange and desorption are poorly understood and controlled, rendering the technique qualitative despite the sophisticated analytical tools employed. Activated charcoal concentrates many fluorescent compounds, often increasing background and undermining the "amplification" attributed to such detectors. Furthermore, the high pH of elutants can cause significant shifts in fluorescence spectra (KASS 1992), compromising the sensitive spectral separation of multiple tracers.

Adoption of appropriate analytical protocol allows defence against many of these weaknesses. However, it is seldom considered cost effective to run the multi-level system of controls and calibrations required in field sampling for low concentration fluorescent tracers. A well resolved tracer breakthrough curve is extremely unlikely to arise from accidental contamination, or background from previous traces, and therefore provides a far stronger demonstration of a trace than a single positive detector. Tracer breakthrough curves also permit hydraulic analysis to be undertaken (e.g., SAUTER 1992). Serial quantitative analysis allows estimation of tracer recovery, a powerful test of the completeness of a trace. Furthermore, time-mass data provide the key to developing contaminant transport and dynamic discharge models.

Spectrofluorometry of multiple water samples has not been adequately explored, presumably the costs are considered too high. Filter fluorometry is an excellent complement to detector spectrofluorometry, providing serial quantitative concentration data.

In combination with discharge data, tracer recoveries can be estimated. Accidental contamination is usually self-evident in filter fluorometric data, and is virtually impossible with continuous flow filter fluorometry. The primary disadvantage of filter fluorometers is the considerable capital and logistic cost involved in deployment of water samplers or fluorometers, in sample handling and processing and in data base management. Filter fluorometers have very good sensitivity, but separation of multiple tracers and background is much more difficult. Hydraulic analysis and tracer recovery require monitoring of discharge, another time-demanding field technique.

As intensive users of filter fluorometers we have been attempting to improve fluorometric techniques, experimental design and protocol to maximise efficiency and information yield. The remainder of this paper identifies some technical problems and solutions associated with the Model 10, some general improvements in protocol in filter fluorometry and a first attempt at formalising the design of simple tracer experiments.

2. Filter fluorometric technique

The majority of our work has involved the use of the Turner Designs Model 10 Series fluorometer, either in continuous flow mode or for laboratory analysis of grab samples collected automatically or manually. The Model 10 is a robust, rather dated instrument which remains the most common filter fluorometer used in fluorometric tracing in Anglo-America. The field version of the Model 10 is weather proof. Power requirements are flexible, but high. The instrument has excellent dynamic range obtained by automatic switching through $\times 1$ – $\times 3.16$ – $\times 10$ – $\times 31.6$ and manual $\times 1$ – $\times 100$ ranges. (The $\times 3.16$ multiplier is the square root of ten, and allows flexible calibration and conversion of fluorescence to concentration.) The instrument is read on a two range analogue panel meter. Operational calibration requires a blank and single standard, although more thorough tests should be run periodically. Excellent telemetry connections allow attachment of a programmable data logger, not only to collect data, but to substantially upgrade the performance of the instrument. We have used the Campbell Scientific CR10 and 21X, although any good programmable data logger could be used.

Table 1 provides a summary of technical problems we have encountered with filter fluorometry of grab samples and in continuous flow mode, using the Turner Model 10. In addition to the external logger, sample handling and data processing protocol has been improved, and a preliminary attempt made at developing tools to aid in test design. Further details can be obtained from SMART & ZABO (1997), or the senior author.

	Problem	Mode	Solution
1.	Limits on sampling frequency and data transfer	CF/Grab	Record to external logger.
2.	Output noisy and inefficient for reading and calibration	CF/Grab	A/D conversion and averaging using logger.
3.	Conversion to ppb complex	CF/Grab	External processing using logger
4.	Slow range change (esp. on rising limb)	CF	External control using logger
5.	Automatic range limited	CF	Automate using logger and servo motor
6.	Filter changes slow	Grab	Allen panel screws, multiple fluorometers
7.	Power consumption too high for remote areas	CF/Grab	Micro-hydro, (solar)

Table 1. Summary of problems with the Turner Designs Model 10 Series fluorometer and proposed solutions. CF implies applications with continuous flow fluorometry, "Grab" indicates analysis of discrete water samples.

1. Data frequency and transfer

The Model 10 is conventionally read from an analogue panel meter, or (in continuous flow mode) drives an analogue chart recorder. These data displays are invaluable for quick visual interpretation, but do not lend themselves to compilation of accessible, high frequency data. Telemetry connections permit easy external logging to obtain a crude digital voltage record of concentration and range time series. Machine readable data are a great improvement over chart or manual recording. Automated recording of grab sample analysis is less advantageous, at the very least a manual record is kept to clarify inconsistencies in the logger record.

2. Noise rejection and calibration

Instrument noise makes reliable reading or analogue recording of the panel meter difficult, especially at low concentrations or if the sensitivity adjustment is set too high. Much of the instrument instability is random or "white" noise which can be rejected by compiling averages. The external logger is easily programmed to convert the analogue signal to digital form and to output the average of a swath of readings, and this has been demonstrated to improve the precision of our results. Logger-averaging has also been applied successfully to grab sample analysis, using a manually-triggered burst of readings and digital display. External averaging also significantly improves instrument accuracy, by allowing more precise calibration.

3. Conversion to concentration.

Converting panel reading or external voltage readings to concentration requires some work, and can be a source of error, especially when processing uncorrelated grab samples, or when averaging across range changes in continuous flow mode. Furthermore the conversion algorithm depends on the current calibration settings. A robust logger algorithm has been developed to convert external readings of the analogue signal and range output to parts per billion. The appropriate multiplier is selected empirically during calibration. Processing to ppb eliminates errors arising when compiling averages across range changes; ppb is continuous across the break, whereas voltage is not.

Cross range calibration may drift on older or abused instrument. Such error can be compensated for within the conver-

sion algorithm, rather than by expensive internal refurbishment. Raw data are recorded should there be doubts about the reliability of the processing algorithm.

4. Slow range change

Automatic range changing is a major advantage in continuous flow mode. However, range-changes take several seconds, especially during rising tracer concentrations when the instrument steps slowly through two redundant ranges. Instrument readings are spurious during range changes and this can become critical with dilution gauging or very rapid tracer breakthrough. The solution is to use the logger to force stepping through redundant ranges rapidly, and to suspend data collection during the adjustment phase.

5. Limited Automatic Range

Despite excellent dynamic range, the manual $\times 1$ - $\times 100$ limits automated operation. The full dynamic range is needed where peak tracer concentrations cannot be anticipated or controlled by tracer mass adjustments. The logger has been programmed to identify conditions in which manual switching is required. This can be used to trigger an alarm if an operator is available. For full automation, an external reversible motor is attached to the $\times 1$ to $\times 100$ switch. A timed burst of appropriately polarised D.C. power drives the motor for the required number of revolutions. This is the most arduous adjustment to the instrument, but requires only modest machine and electronic expertise.

6. Filter changes

Switching filters can take ten minutes or more. An inexpensive adaption (courtesy, P.L. Smart, University of Bristol) is to replace the slot screws on the front panel with "Allen" screws (hex-sockets) which allows use of a speed driver. (Light lubrication is essential as the screws are tapped into aluminium.)

7. Power consumption.

The Model 10 consumes some 24W of power which requires mains supply, or independent power generation. Continuous flow pumps are more power-demanding. Gasoline generators add considerably to the logistic load and are best avoided. Adequate

	Detector-Spectrofluorometry		Water Samplers-Filter Fluorometers		Continuous Flow Filter Fluorometry (n ≤ 3)	Discharge Stage sites/ calibrations
	Detectors	Spectro-fluorometers	Water Samples	Filter Fluorometers		
Hydrogeography	N.n.v	1	N.v.f	1..n	N.n	N / 1..10
Time of Travel	N.n.v.f	1	N.v.f	1..n	N.n	N / 1..10
Time-Conc ⁿ .	n.a		N.v.f	1..n	N.n	N / 1..10
Hydraulics	n.a		N.v.f	1..n	N.n	N / 1..10
Recovery	n.a		N.v.f	1..n	N.n	N / 1..10

Table 4. A matrix to allow design of appropriate resource allocation for tracer tests. Columns list instrument options; rows research questions. n.a. indicates that a technique is not applicable. N is the number of sample sites; n is the number of tracers; v the number of replicates, f the sampling frequency. 1..n indicates that a single filter fluorometer can be used and reset n times, or (more efficiently, n fluorometers can be used in parallel. The number of discharge calibrations depends on the variability of stage at the N sites.

photovoltaics are prohibitively expensive and ill-suited to temporary deployment. Micro hydro has proven effective, given adequate head (~1 m with large discharge). A lower power fluorometer

3. Handling and processing protocol

1. Water sample containers

Grab water samples and elutant samples are normally decanted into a rinsed cuvette for analysis, and, where sample is in short supply, returned to the sample bottle for subsequent analysis or archiving. This is time consuming and, with alkaline elutant, hazardous. Handling of exposed samples invites contamination, which is especially serious when a single charcoal detector provides a solitary data point. Serious fluorometric contamination is positive and occurs when the operator handles both dye concentrates and samples or sampling equipment.

A solution (adopted from C. Alexander, University of Minnesota) is to use sample bottles that can be inserted directly into the fluorometer. Direct insertion of samples has significant advantages in processing efficiency and reduction of contamination. There is some loss of precision in using inexpensive glass bottles, but optically flawed bottles can be rejected, and the large increase in efficiency allows more samples to be collected in compensation. If reusing sample bottles to reduce waste, care should be taken that dye does not become lodged in cardboard cap liners; we use a cap liner of cling-film to prevent this.

2. Temperature compensation

Fluorescence for the rhodamine dyes has significant inverse temperature coefficients of ~2-3% per °C (KÄSS, 1992) which may be significant in quantitative applications, especially when working in the field. In continuous flow fluorometry, a temperature sensor can be added to the fluorometer outfall, and a temperature compensation subroutine added to the data processing. This requires the temperature of calibration and the correction factor (KÄSS, 1992) to be recorded in the logger. Alternatively, temperature can be recorded and compensation undertaken during post-processing.

Paradoxically, temperature compensation is more difficult with grab samples, where some attempt can be made to homogenise sample temperature. Problems arise because the sample compartment is warm, and fluorescence declines as a sample warms up. Temperature cannot be read during analysis because samples

become thermally stratified, and the temperature sensor must not interfere with the light path. Our approach is first to immerse samples and standards in a circulating water bath at ambient temperature. We have adapted our sample compartment to allow forced ventilation of outside air. Insertable sample bottles are an essential part of this strategy. This approach not only bypasses the temperature compensation problem, but it also encourages frequent reference to calibration standards.

3. Cross Fluorescence

Many tracer tests involve the use of multiple tracers or demonstrate significant natural background. Unfortunately, the characteristic fluorescence spectra of tracers can overlap. Fluorescent background typically peaks in the blue regions of the emission spectrum, but can still be significant at green and red wavelengths. Fluorescence reading can therefore be ambiguous, especially with filter fluorometers. It is possible to correct for "cross-fluorescence," providing arbitrary standards are available for the relevant fluorescent compounds. However, there is little evidence for such practices. Corrections for cross-fluorescence are provided in SMART & ZABO (1997) and KÄSS (1992).

Cross fluorescence corrections are simple to incorporate into machine data processing and should be made routinely for both filter and spectro-fluorometry, whenever multiple tracers are in use, even if only one tracer is present. This is considered good protocol, providing a secondary level of robustness in analytical procedures. Cross-fluorescence correction also provides an excellent method of coping with variable concentrations of background, providing it is possible to characterise background with a suitable "standard."

4. Design of tracer tests

1. Experimental Design

Efficient tracer test design is often attributed to expert intuition, but some elements are amenable to scientific design. For example, WORTHINGTON et al. (1995) provide an efficient algorithm for predicting tracer mass, based upon distance, spring discharge and peak concentration. The following is a first attempt to develop a simple "expert system" to aid the design of tracer tests.

Compound tracing can be defined as tracing involving more than a single sampling site. (N>1). Multi-tracing implies the use of multiple tracers (n >1), usually implying multiple injection sites. Replicate tracing implies repetition of particular traces (v >1). The other operational parameter is sampling frequency (f), crudely

presented as samples per trace. The resources required for tracer testing constitute the equipment listed in Table 4, plus consumables such as dye, and manpower. The nature of a test depends upon the question being asked, the complexity of the system, available information and budget. Table 4 has been developed to formalise appropriate resource allocation for distinctive questions, and as a guide to management of key issues in design of appropriate instrument deployment. For example, hydrogeographic questions are best tackled using detector-spectrofluorometry. In contrast, the number of continuous flow fluorometers to be deployed in a quantitative test is $n \times N$, so that the highest level of efficiency is obtained for replicate, high resolution in simple systems (n and N are minimised).

2. Practical optimisation of tracer tests

Table 4 is not intended to over-simplify tracer testing. Fundamental groundwork in reconnaissance hydrogeology is essential, and remains highly dependent on the experience, skill and insight of the operator. Equally, it is inefficient to tackle quantitative problems without an established hydrogeography.

There are also many practical ways to optimise tracing. For example, G. Davies (Cambrian Ground water Inc., Oak Ridge Tn.) advocates a series of single tracer injections progressing headward from a continuously monitored spring site. This allows efficient compilation of knowledge with a minimum of sample processing. Similarly, it may be possible to analyse water from adjacent sampling sites sequentially using electronically controlled valves (e.g., FOUNTAIN 1994). In distributary karst systems springs may be classified into "family groups" exhibiting similar tracer breakthrough. It may only be necessary to sample a single member of a spring family. Stage monitoring and discharge rating are expensive, but can be rationalised. Monitoring should concentrate on high mass (=discharge \times concentration) springs, and overflow members in distributary spring systems. "Underflows" exhibit little variation and do not require continuous monitoring of stage. The gains in sample processing speed described above make the water sampler-filter fluorometer strategy most efficient for quantitative compound multi-tracing. Continuous flow fluorometry may also be constrained by problems like turbid water or inadequate power. In complex traces, however, the real-time data from a "master" continuous flow fluorometer can be invaluable in management of sampling tactics.

In addition to the "minimalist" strategies presented in Table 4, data verification must also be considered. Continuous flow fluorometry does not preserve samples for archiving or verification, and instrument failure can result in irremediable data loss. Apart from designing a robust monitoring strategy, charcoal detectors and manual water samples can be collected and archived at little additional cost (providing samples are protected from bio- and photo-degradation; KÄSS 1992). Verification of detector-spectrofluorometric tracing is more difficult and requires multi-level blanks for background, charcoal, elutant etc.

3. Borehole deployment

While design of tracer tests for conventional karst tracing is relatively easy, many practical problems involve "mid-aquifer" applications and boreholes. The arbitrary position of boreholes and forced gradients means that borehole tracer tests may not reveal solutionally enhanced permeability. Nevertheless, the adapted Model 10 is well suited to forced gradient experiments, and has been routinely used to continuously monitor water pumped from a borehole. However, natural gradient tracer experiments are much more difficult, and should be conducted with small samples collected with replacement (e.g. NOVAKOWSKI, 1992). The pressing need is for the development of inexpensive versions of *in situ* fluorescence sensors similar to those described by BARCZEWSKI &

MARSCHALL (1992) and BENISCHKE & LEITNER (1992).

5. Conclusions

The enhancements suggested in this report permit the venerable Turner Model 10 to be operated as a leading edge filter fluorometer, comparable to the new Turner 10 AU, and may make filter fluorometry more viable as an applied tool. Recommendations on protocol and test design should be considered by any practitioner interested in undertaking robust and defensible water tracing. Despite the complementarity of filter and spectrofluorometer techniques, there remain critical technical and operational limitations in tracer testing. Low power, inexpensive fluorescence sensors should be able to reach sub ppb sensitivity and are seen as complementary to the modern arsenal of water tracing tools.

Acknowledgments

Field and laboratory work reported here has been generously funded by the Natural Sciences and Engineering Research Council of Canada, and the University of Western Ontario. Aspects of this work have involved collaboration with C. Alexander (University of Minnesota), S. Worthington and D.C. Ford (McMaster University) and G. Davies (Cambrian Ground water Inc.). Many students have participated in field experiments in fluorometric tracing.

References

- BARCZEWSKI, R., & MARSCHALL P., 1992. Development and application of a lightfibre fluorometer for tracer tests. In, HÖTZL, H., & WERNER, A. *Tracer Hydrology* Balkema, Rotterdam, 33–40.
- BENISCHKE, R. & LEITNER, A., 1992. Fibreoptic fluorescence sensors—an advanced concept for tracer hydrology. In, HÖTZL, H., & WERNER, A. *Tracer Hydrology* Balkema, Rotterdam, 33–40.
- FOUNTAIN, A.G., 1994. Automated system for measuring and recording fluorometric data from multiple sources. *U.S. geol. Surv. Water Supply Paper* 2340.
- KÄSS, W. 1992. *Geohydrologische Markierungstechnik*, Gebrüder Bornträger, Stuttgart, 519 pp.
- NOVAKOWSKI, K., 1992. The analysis of tracer experiments conducted in divergent radial flow fields. *Water Resources Research* 28, 3215–3225
- QUINLAN, J.F., 1986. Discussion of "Ground water tracers" by Davis et al. (1985) with emphasis on dye tracing especially in karst terranes. *Ground water* 24, 253–259; 396–397.
- SAUTER, M., 1992. Quantification and forecasting of regional ground water flow and transport in a karst aquifer (Gallusquelle, Malm, S.W. Germany). *Tübinger Geowissenschaftliche Arbeiten* (TGA) C13, 251 pp.
- SMART, C.C. & ZABO, L., 1997. Some developments in fluorometric tracing of ground water. *VI Multidisciplinary Conference on Sinkholes and the Engineering and Environmental Impacts of Karst*. In press.
- WORTHINGTON, R.R.H., D.C. FORD & C.C. SMART, 1995. Guidelines for the quantity of dye needed for quantitative tracing to springs in carbonate rocks. In G. GUNAY, L. TECZAN, A. ATILA, *International Symposium and Seminar on Karst Waters and Environmental Impacts*, Beldibi, Turkey.

Perspectives offertes par la mesure en continu des traceurs fluorescents dans le karst

par P. Meus¹, M. Bakalowicz², W. Käss³, B. Barczewski et G. Schmid⁴

¹ Laboratoire Souterrain du CNRS, F-09200 Moulis

² CNRS, URA 1767 "Géofluides, Bassins, Eau", Groupe de Géochimie, F-34095 Montpellier et BRGM, Direction de la Recherche, F-34000 Montpellier

³ Mühlematten 5, D-79224 Umkirch

⁴ VEGAS, Institut für Wasserbau, Universität Stuttgart, D-70550 Stuttgart

Abstract

A continuous tracer test lasting several months was performed between an annex-to-drain system (La Peyrere cave) and the main outlet (Las Hountas) of the Baget karst system. Uranine at the spring was recorded with a 10 mn intervall thanks to a flow-through cell automatic fluorimeter. The breakthrough curve of the tracer reflects the dynamics of the system.

1. Introduction

Un des problèmes majeurs dans la prédiction du transport des polluants dans le karst est sans aucun doute la manière dont varient les réponses impulsionnelles. En raison de la structure particulière du drainage, non seulement ces réponses varient suivant l'état hydrodynamique du système mais de plus les variations peuvent être discontinues. Pour ces raisons, la plupart des aquifères karstiques ont un comportement typiquement non linéaire. Divers auteurs ont tenté de tenir compte d'une variation de la réponse impulsionnelle avec le débit de traçage (NIEMI, 1977; ZUBER, 1986; DZIKOWSKI, 1995). Si les premières solutions proposées s'avéraient trop restrictives (entre autres la condition de volume constant), en revanche les dernières généralisations de l'intégrale de convolution permettent à l'heure actuelle une approche plus réaliste. L'expérience décrite ci-dessous consistait en un traçage en continu, pendant une période la plus longue possible, sur un système karstique, de façon à tester, avec une fonction d'entrée parfaitement connue, les réponses à un éventail le plus large possible d'états du système, et ainsi pouvoir traiter ces dernières d'un point de vue statistique. Elle a été rendue possible grâce à l'utilisation d'un fluorimètre de terrain spécialement conçu pour le dosage de l'uranine en continu à la source.

2. Le système du Baget et le traçage en continu

Le débit moyen du système du Baget est de 0,5 m³/s. Ses réserves (volume dynamique moyen de l'ordre de 1,5.10⁶ m³) proviennent d'une part de la recharge continue par les écoulements allochtones qui se perdent au contact des calcaires et, d'autre part, du stockage de l'eau dans les zones latérales au drain, dans des vides karstiques parfois importants appelés les "systèmes annexes". L'un de ces systèmes annexes, le gouffre de la Peyrère, avait fait l'objet d'un pompage à gros débit (BAKALOWICZ, CROCHET, D'HULST, MANGIN, MARSAUD, RICARD et ROUCH, 1994) mettant en évidence l'absence de réserve importante en dehors du conduit karstique lui-même. C'est précisément ce gouffre qui a été choisi comme lieu d'injection du traceur dans le but de préciser les mécanismes de la recharge et de la vidange de ces systèmes annexes. L'injection d'uranine a eu lieu, depuis une cuve de 3000 l placée dans le gouffre, grâce à une pompe doseuse équipée d'un clapet de maintien de pression à 3 bars pour s'affranchir des fluctuations du plan d'eau d'environ 25 m au-dessus du point d'injection. Le débit constant était de 55 ml/mn et la concentration de la solution mère de 3 g/l, plusieurs essais et modélisations ayant permis de trouver un compromis entre une concentration gênante à la source et une concentration mesurable (> 0,1 ppb) malgré la dilution par les crues. Le fluorimètre comporte une cellule à flux continu équipée d'une diode comme source d'excitation et reliée au boîtier électronique de mesure via un système de fibre optique (BARCZEWSKI, KÄSS, SCHMID und WERNER, 1996).

3. Interprétation du traçage et conclusion

Une courbe de restitution de l'uranine à l'exutoire de Las Hountas a ainsi été obtenue au pas de 10 mn pour la période de décembre 1996 à avril 1997. Cette courbe, comparée aux fluctuations naturelles du système (pluie, débit, conductivité, température) également mesurées en continu, permet une interprétation particulièrement fine de la réponse. Elle confirme en outre l'existence de non linéarités qui peuvent s'expliquer par la déconnexion de parties du réseau lorsque le niveau d'eau devient inférieur à celui de certains conduits préférentiels. L'expérience montre que, malgré ces non linéarités, le modèle de convolution à débit variable de DZIKOWSKI (1995) est en bon accord avec le fonctionnement observé du système karstique.

En conclusion, la mesure en continu des traceurs fluorescents injectés artificiellement dans les systèmes karstiques constituent un excellent moyen de caractériser la dynamique de ces systèmes. Cette approche phénoménologique renseigne sur le degré de prédictibilité, une notion dont la connaissance apparaît de plus en plus comme indispensable pour une gestion correcte des ressources en eau.

NB: Cette recherche a été financée dans le cadre du programme Capital Humain et Mobilité de la Communauté Européenne. Nous tenons à remercier Mme J. Daffis et Mr G. Fontanini, techniciens au Laboratoire Souterrain, pour leur aide précieuse sur le terrain.

Dripwater monitoring at Grotta di Ernesto (NE-Italy): a contribution to the understanding of karst hydrology and the kinetics of carbonate dissolution

Andrea Borsato

Museo Tridentino di Scienze Naturali, via Calepina 14, I-38100 Trento, Italy

Abstract

Dripwater monitoring at Grotta di Ernesto (NE- Italy) reveals the different hydrological functioning of slow- and fast-dripping stalactites. The conductivity record of fast dripping stalactites is punctuated by several abrupt negative peaks following strong rainfall episodes with a response time of a few hours. During these "infiltration event" the discharge increases immediately, and the dripwater becomes strongly undersaturated. The recovery of the previous condition needs from 10 days up to two months which indicates the progressive increase of the residence time of the water in the aquifer. In low-dripping soda straws no infiltration events are recorded, and the water is near the saturation state throughout the year. Nevertheless, the conductivity trend is similar to that of fast-dripping stalactites, which indicates a direct connection of the slow- and fast-dripping stalactite plumbing systems.

Riassunto

Il monitoraggio della acque di percolazione nella Grotta di Ernesto (Trentino-Italia) ha evidenziato il diverso comportamento idrogeologico di stalattiti con differenti velocità di gocciolamento. La registrazione annuale della conducibilità di stalattiti a percolazione veloce è caratterizzata da improvvisi picchi negativi connessi all'infiltrazione di acqua poco mineralizzata a seguito di forti piogge. Il ripristino dei valori di conducibilità precedenti l'evento infiltrativo richiede da 10 a più di 30 giorni, e riflette il progressivo aumento del tempo di residenza dell'acqua nell'acquifero. Stalattiti a cannuccia a percolazione lenta non registrano alcun evento di infiltrazione, e l'acqua è vicina alla saturazione durante tutto l'anno. Tuttavia, l'andamento della conducibilità è simile a quello di stalattiti a gocciolamento veloce, e testimonia una diretta connessione tra i due sistemi di alimentazione.

1. Introduction and aims

The recent introduction of automatic data-loggers to record cave air and water physico-chemical properties (MANGIN, 1985; VIGNA, 1993; CIGNA, 1995; MASSEN *et al.*, 1995; CELI & SAURO, 1996) has greatly improved the quality and number of researches on karst hydrology. In the last few years, this techniques has been applied also to the monitoring of low-dripping morphologies such as fissures, cone stalactites and soda straws (BORSATO, 1996, GENTY *et al.*, 1997) in order to detect the delay time of dripwater after rainfall events, and the seasonality of dissolution-precipitation phenomena.

Caves which develop a few tenth of meters below the surface have the property of recording annual to seasonal climatic information through the physico-chemical characteristics of their dripwaters and speleothem carbonates (BAKER *et al.*, 1993; BORSATO, 1995; GENTY & QUINIF, 1996; FAIRCHILD *et al.*, 1996). Furthermore, for temperate karstic areas, shallow caves dripwater is subjected to seasonal fluctuations of the saturation state from undersaturation to supersaturation due to the limited thickness of the rock above the cave that reduce the residence time of the water in the aquifer (UGGERI, 1992; BORSATO, 1995).

Consequently, such caves are particularly suitable for hydrological studies in order to detect the kinetic of carbonate dissolution in the epikarst zone. The present study informs on the results from one year monitoring of two drippings at Grotta di Ernesto.

2. Cave site and environmental setting

Grotta di Ernesto opens at an elevation of 1167 m a.s.l. (Long. 11° 39' 28" Lat. 45° 58' 37") in Valsugana valley (Trentino, NE-Italy) (DALMERI, 1985) and developed in partially dolomitised oolitic limestones of the Calcarei Grigi Formation

(Lias), which exhibit a good porosity due to the volume reduction during dolomitisation process.

The cave consists of a single downdipping gallery, 2 to 5 m wide, up to 4 m high and 72 m long, which developed along a NW trending subvertical fault, 10 to 25 m below the surface. The original syngenetic morphology of the cave is now blurred by collapse phenomena, and the whole floor is covered by angular blocks, partially coated by flowstones (BORSATO, 1995).

The cave contains a lot of active and fossil speleothems, the age of which ranges from 150,000 years to the Present (BORSATO, 1995; FRISIA *et al.*, 1997) and preserves important Mesolithic findings (DALMERI, 1985). At present, water enters the cave through several drippings, with low (from 0.1 to 2 ml/minute) to medium discharges (up to 50 ml/minute) feeding small, muddy or concretionary pools. Pools show seasonal water level fluctuations: in summer some are dry, in autumn and spring all pools fill up and several overflow.

The cave lies below the timberline, within the deciduous forest vegetation belt consisting of *Fagus*, *Carpinus*, *Larix decidua* and *Abies alba*. The climate is temperate humid, with a mean annual precipitation between 1000 and 1500 mm. From December to March most of the precipitation is snowy, and the snow cover remains until March. Between March and the first half of April, snowmelting occurs.

The cave entrance was discovered and enlarged in 1983, and subsequently closed by an iron door which inhibits air flow in the cave. All this characteristics, make the cave particularly interesting for paleoclimatic and hydrogeological studies.

3. Methods and background

Two single stalactite drips were monitored from 19/06/95 to 19/06/96 by means of two data-logger, which measure water

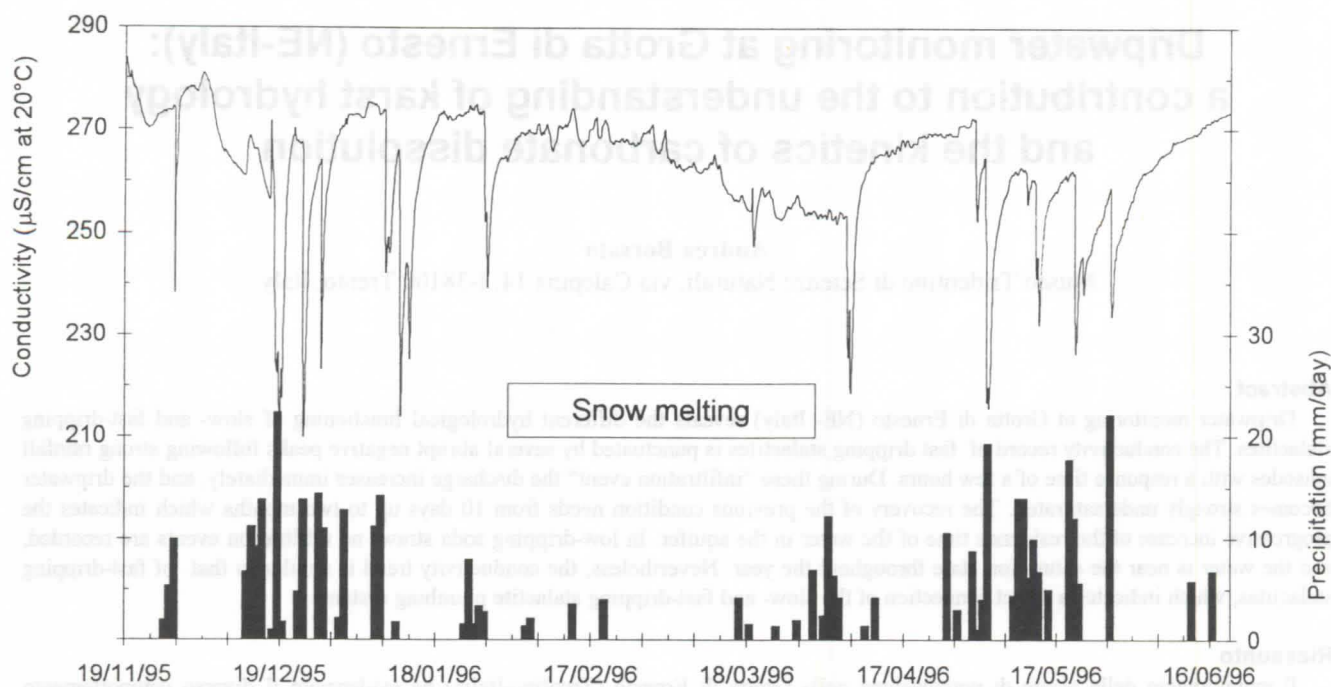

Figure 1: Conductivity record for G2 stalactite compared with precipitation (meteorological station Bieno, 806 m a.s.l.). At each rainfall event higher than ~10 mm/day correspond an abrupt negative shift in dripwater conductivity.

temperature and conductivity. The data-loggers are the "Thermos-data" by DAS-ENEA, which are stored in impermeable boxes, powered by internal batteries, and connected with a double-channel probe. The characteristics of the probes are the followings: Temperature: range -10 to +40°C, resolution 0.01°C, accuracy +/- 0.2°C. Conductivity: range 10 to 1000 µS/cm; resolution 1 or 0.1 µS/cm; accuracy +/- 2 µS/cm.

The two monitored drips, located on the roof of the main chamber of the cave which developed about 15 m below the surface, are a slow dripping soda straw (G1) and a fast dripping cylindrical stalactite (G2). The drip of the soda straw G1, which fed an active cone stalagmite (stalagmite ER76, see FRISIA *et al.*, 1997) was collected with a funnel positioned at the tip of the straw. This soda straw is actually growing, like others straws in the cave which exhibit clear annual growth banding (TOOTH *et al.*, 1996). The drip rate during the whole monitoring period, varied from 0.07 to 1.37 ml/minute (mean 0.43 ml/m). The drip of the cylindrical stalactite G2, which is directly feed by a subvertical fissure, was collected with a funnel positioned at the splash-site, about 2.5 m from the stalactite tip. The drip rate throughout the monitoring period varied irregularly from 3.33 to 34.6 ml/minute (mean 12.7 ml/m). At present, the impact point of G2 drops identifies the apex of a large flowstone generated from it.

For both drippings, the interval between two measurements was 1 hour (reduced to 3 hour in successive elaborations). At the end of the monitoring period, the bottom of the samplers were sediment-free and no precipitation occurred within them.

During the monitoring period, several water samplings allowed to measure the exact drip-rate and drop volume, and analyse the physico-chemical properties of the waters. This also allowed for the calibration of the conductivity probes, which were affected by instrumental drift due to adhesion of air bubbles on the electrodes.

4. Results

Fig. 1 shows the seven-month record of G2 stalactite. The most striking feature in its conductivity record are several abrupt

drops of about -20 to -50 µS/cm, followed by gradual increase in conductivity. By comparing this record with the precipitation data for the same period from the meteorological station of Bieno (806 m a.s.l., 12 km WNW from the cave) it results that each negative peak in conductivity corresponds to a precipitation event exceeding 10 mm/day that occurred on the same day, or on the day before. The recovery of the previous conductivity values takes place in two separate phases: an initial rapid increase, which lasts about one week, and a successive slow increase, which can last 2 months or more and tends towards the asymptotic value of about 280 µS/cm. In most of the cases, the rise in conductivity does not reach this asymptote, but it is interrupted by the successive abrupt decrease.

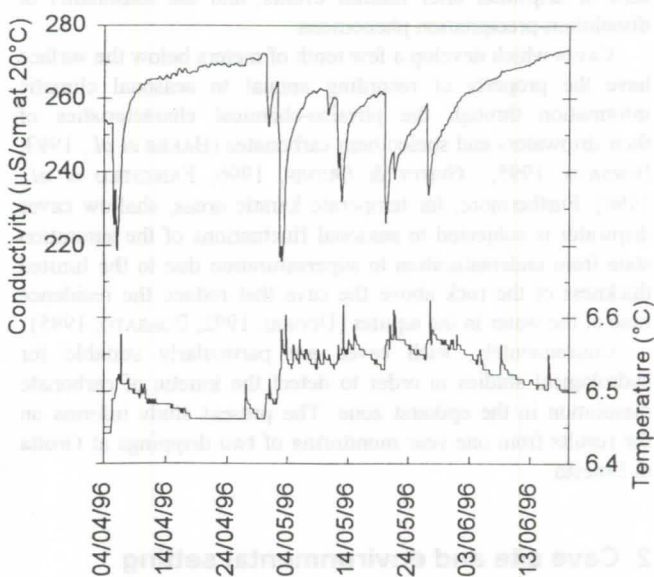

Figure 2: Conductivity and temperature records for G2 stalactite. To each conductivity drop corresponds a sudden increase in temperature. The secondary positive temperature peaks in May and June are due to tourist visits.

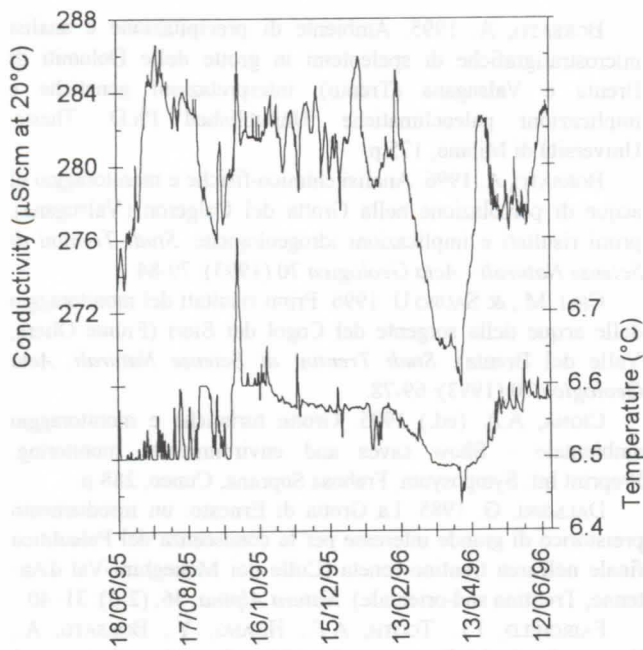

Figure 3.: One year conductivity and temperature records for G1 soda straw.

Each drop in the conductivity of G2, is accompanied by a slight, sudden increases in water temperature of about 0.05°C (Fig. 2). Also in this case the recovery of the previous conditions occurs through two phases: a first rapid decrease (about -0.04°C) and a successive slow damping. These series of sudden peaks clearly correspond to infiltration of low-mineralised water, which immediately follows major rainfall events.

In the one-year conductivity and temperature records of G1 soda straws (Fig. 3) the most remarkable feature is the limited seasonal conductivity fluctuations with summer values (280 to $286\ \mu\text{S}/\text{cm}$) which are only slightly higher than those of winter and early spring (268 to $280\ \mu\text{S}/\text{cm}$).

By comparing the two data-logger records (Fig. 4) it is possible to observe an overall seasonal similarity for both temperature and conductivity, with a gentle decrease in $T^{\circ}\text{e}\ \chi$ from January to March and a more rapid increase during April. For both G1 and G2 the lowest conductivity values (except for the infiltration event in G2) are recorded during late winter and early spring, and culminate at the end of March. This period corresponds to the progressive melting of the snow cover, which is completed by early April.

5. Discussion

The conductivity of dripwater is a direct function of the total mineralisation, i.e. of the Ion Activity Product (IAP) which, in pure limestone aquifers, represents fairly well the total CaCO_3 in solution (BAKALOWICZ, 1974).

In Grotta di Ernesto G1 and G2 drippings, the IAP is mostly identified by Ca^{2+} (2.5 to $2.95\ \text{meq}/\text{l}$) and HCO_3^- (2.8 to $3.1\ \text{meq}/\text{l}$), the sum of which commonly exceeds 90% of the total ion concentration (BORSATO, 1995). This means that strong fluctuations in conductivity can only be explained by differences in the total dissolved CaCO_3 . Furthermore, G2 dripping is commonly undersaturated, with a Saturation Index for calcite from -0.4 to $+0.2$ (before the drop splashes), which indicates that, during several periods, the water can potentially dissolve more carbonate. This is also recorded by the conductivity record of G1 dripping which is generally over $10\ \mu\text{S}/\text{cm}$ higher than that of the fast dripping G2 site (Fig. 4).

The overall trend of G2 conductivity directly reflects the rainfall pattern, which strongly influence the calcite saturation state: during infiltration events the drip-rate increases immediately, and dripwater becomes strongly undersaturated. Water slowly shifts towards the saturation state during dry periods, when conductivity increases towards the asymptote and the drip-rate slows down. The first rapid conductivity increase probably corresponds to the soil and rock drainage after the complete soil imbibition, whereas the slow positive trend towards the asymptote identifies the progressive increase of water residence time in the aquifer. Conductivity of G2 responds

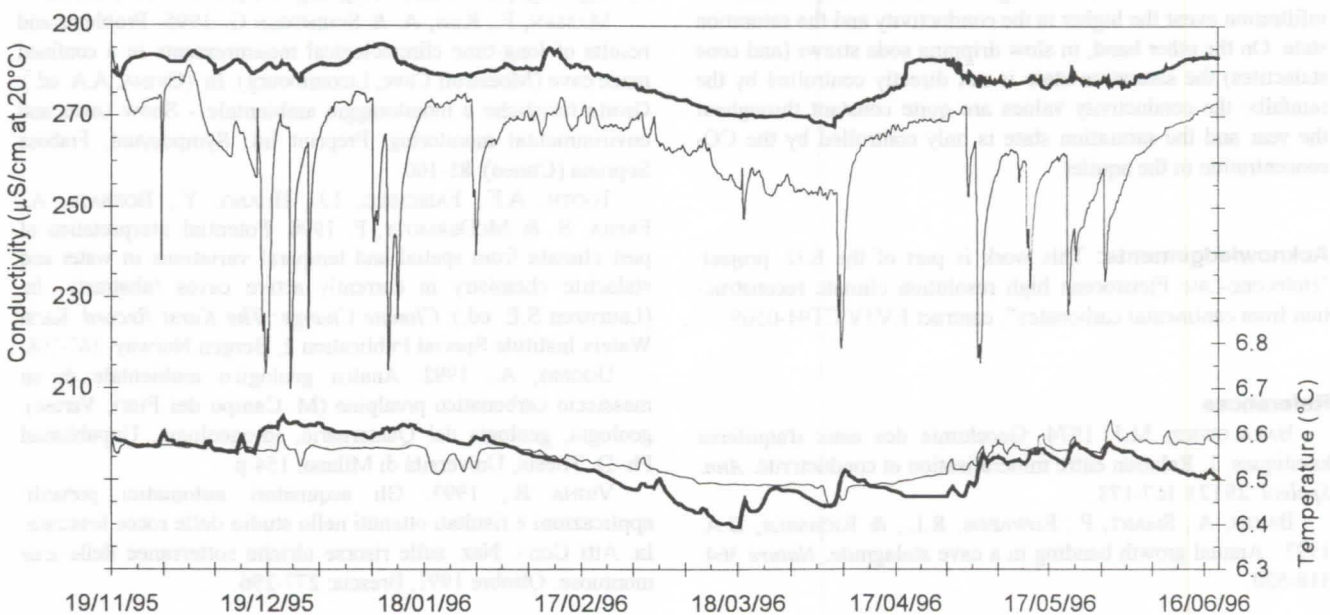

Figure 4.: Combined conductivity and temperature (daily running mean) records for G1 (bold lines) and G2 (thin lines) stalactites. Note that conductivity of G1 dripping is generally over $10\ \mu\text{S}/\text{cm}$ higher than that of the fast dripping G2.

immediately (probably less than 12 hours) to the infiltration events, i.e. to precipitation higher than 10 mm/day, as shown by the abrupt decreases of -20 to -50 $\mu\text{S}/\text{cm}$. This sharp conductivity drop indicates the absence of "piston effects" (VIGNA, 1993) i.e. sudden conductivity increases before the negative drop. Piston effects are common in aquifers where waters have a relatively long residence time and "old water" with higher conductivity is pushed into the stalactite-feeding network by the pressure induced by the infiltration event. The immediate response of the system and the lack of piston effects indicate that the mean residence time of G2 drip is really short, probably less than 2 weeks, and is directly correlated with the conductivity. During the infiltration events, the water residence time is probably lower than a day, and progressively increases as conductivity rises towards the asymptote.

For G1 there is no direct relationship between drip-rate and conductivity/calcite saturation state: no infiltration event is recorded by conductivity drops and the only remarkable phenomena are the low-conductivity values reached during winter and spring snow melting. The overall conductivity trend of G1 is similar to those of G2 record, therefore, we can infer that the feeding system is the same for both stalactites, but also that the plumbing system of G1 is too narrow to allow for the sudden arrival of the infiltration event waters at the soda straw. Because of this correlation, it is possible to infer that the mean residence time of G1 water is only a little bit longer than that of G2, probably between one and two months. However, this time-span, which is related to the good porosity of the rock above the cave, is enough to buffer the conductivity fluctuation. In this case, the most important mechanisms controlling the water saturation state are seasonal episodes like snow melting in spring and higher CO_2 production during summer and autumn.

6. Conclusion

Dripwater monitoring gives precious insight upon karst hydrogeology and the feeding mechanisms of stalactites. In Grotta di Ernesto the conductivity and saturation state of fast dripping stalactites is directly controlled by the infiltration events and, as a whole, the longer is the time elapse from the infiltration event the higher is the conductivity and the saturation state. On the other hand, in slow dripping soda straws (and cone stalactites) the saturation state is not directly controlled by the rainfalls: the conductivity values are quite constant throughout the year and the saturation state is only controlled by the CO_2 concentration in the aquifer.

Acknowledgements: This work is part of the E.U. project: "Holocene-Late Pleistocene high resolution climate reconstruction from continental carbonates", contract EV5V CT94-0509.

References

BAKALOWICZ, M.J. 1974. Geochimie des eaux d'aquiferes karstiques. 1. Relation entre mineralisation et conductivité. *Ann. Speleol.* 29 (2): 167-173.
 BAKER, A., SMART, P., EDWARDS, R.L., & RICHARDS, D.A. 1993. Annual growth banding in a cave stalagmite. *Nature* 364: 518-520.

BORSATO, A. 1995. Ambiente di precipitazione e analisi microstratigrafiche di speleotemi in grotte delle Dolomiti di Brenta e Valsugana (Trento): interpretazioni genetiche e implicazioni paleoclimatiche. Unpublished Ph.D. Thesis, Università di Milano, 175 p.

BORSATO, A. 1996. Analisi chimico-fisiche e monitoraggio di acque di percolazione nella Grotta del Calgeron (Valsugana): primi risultati e implicazioni idrogeologiche. *Studi Trentini di Scienze Naturali - Acta Geologica* 70 (1993): 79-84.

CELI, M., & SAURO U. 1996. Primi risultati del monitoraggio delle acque della sorgente del Cogol dei Siori (Fiume Oliere, Valle del Brenta). *Studi Trentini di Scienze Naturali, Acta Geologica* 70 (1993): 69-78.

CIGNA, A.A. (ed.) 1995. Grotte turistiche e monitoraggio ambientale - Show caves and environmental monitoring. Preprint Int. Symposium, Frabosa Soprana, Cuneo, 288 p.

DALMERI, G. 1985. La Grotta di Ernesto: un insediamento preistorico di grande interesse per la conoscenza del Paleolitico finale nell'area trentino-veneta (Colle dei Meneghini-Val d'Antenne, Trentino sud-orientale). *Natura Alpina*, 36, (2-3): 31-40.

FAIRCHILD, I.J., TOOTH, A.F., HUANG, Y., BORSATO, A., FRISIA, S. & McDERMOTT, F. 1996. Spatial and temporal variations in water and stalactite chemistry in currently active caves: a precursor to interpretations of past climate. In: (Bottrell, S. ed.): Proceedings of the fourth International Symposium on the Geochemistry of the Earth's Surface, Ilkley, Yorkshire, July 1996, University of Leeds: 229-233.

FRISIA, S., BORSATO, A., SPIRO, B., HEATON, T., HUANG, Y., McDERMOTT, F. & DALMERI, G. 1997. Holocene palaeoclimatic fluctuations recorded by stalagmites: Grotta di Ernesto (N-Italy). (in this congress).

GENTY, D. & QUINIF, Y. 1996. Annually laminated sequences in the internal structure of some Belgian stalagmites - importance for paleoclimatology. *Journ. Sed. Res.* A66, 1: 275-288.

GENTY, D., DEFLANDRE, G., QUINIF, Y. & VERHEYDEN, S. 1997. Les lamines de croissance des spéléothèmes: origine et intérêt paléoclimatique. *Ann. Soc. Géol. Belg.* (in press)

MANGIN, A., 1985. Progrès récentes dans l'étude hydrogéologique des karst. *Stylogia*, 1 (3): 239-257, Leiden.

MASSEN, F., KIES, A. & SCHINTGEN G. 1995. Problems and results of long-time climatological measurements in a confined maze cave (Moestroff Cave, Luxembourg). In: (CIGNA, A.A. ed.): Grotte turistiche e monitoraggio ambientale - Show caves and environmental monitoring. Preprint Int. Symposium, Frabosa Soprana (Cuneo): 85-100.

TOOTH, A.F., FAIRCHILD, I.J., HUANG, Y., BORSATO, A., FRISIA, S. & McDERMOTT, F. 1996. Potential interpretation of past climate from spatial and temporal variations in water and stalactite chemistry in currently active caves (abstract). In: (Lauritzen S.E. ed.): *Climate Change: The Karst Record*. Karst Waters Institute Special Publication 2, Bergen Norway: 167-168.

UGGERI, A., 1992. Analisi geologico ambientale di un massiccio carbonatico prealpino (M. Campo dei Fiori, Varese): geologia, geologia del Quaternario, idrogeologia. Unpublished Ph. D. Thesis, Università di Milano, 154 p.

VIGNA B., 1993. Gli acquisitori automatici portatili: applicazioni e risultati ottenuti nello studio delle rocce fessurate. In: Atti Conv. Naz. sulle risorse idriche sotterranee delle aree montuose. Ottobre 1991, Brescia: 277-296.

Données hydrogéochimiques sur quelques karsts du sud-est asiatique

par François Brouquisse,

Association Pyrénéenne de Spéléologie, 14 Cité Foch - 65000 - Tarbes, France

Abstract

Between 1985 and 1996, some 120 samples were collected from karst environments, during APS caving expeditions in Thailand, Indonesia and Laos. Analytical results are given: ions contents and computed variables for CO₂-CaCO₃ system. Extensive sampling is representative. Factor analysis bears evidence for different water types according to karst hydrology and soil and vegetation factors. Hydrochemical characteristics of these water samples don't show difference with those of karst waters in temperate climates.

Résumé

Au cours d'explorations spéléologiques de l'APS de 1985 à 1996, plus de 120 prélèvements d'eau ont été analysés sur divers sites karstiques de Thaïlande, Indonésie et Laos. Les principaux résultats sont présentés: ions majeurs et mineurs, paramètres calculés du système calco-carbonique. L'analyse factorielle des données conduit à identifier plusieurs familles d'eaux, notamment en fonction de la dynamique du système hydrologique et des caractéristiques de couverture végétale et pédologique. Les caractères hydrochimiques de ces eaux ne les distinguent pas de celles des karsts de régions tempérées.

1. Cadre général

Peu de travaux sur la chimie des eaux et la dynamique du CO₂ ont été menés sur les karsts de Thaïlande et d'Indonésie. On citera entre autres, ceux de PITMAN (1978) sur Phangnga et de BALAZS (1968) en Indonésie. Cette note résume les principaux résultats obtenus entre 1985 et 1996 sur plus de 80 sites différents. Ceux-ci assurent une bonne représentativité: écoulements de surface, pertes, émergences, percolations et gouttages en cavités, circulations au niveau du karst noyé (Tab.1). Cinq régions ont été plus particulièrement étudiées: Chiang Dao au nord de Chiang Maï, la Nam Lang près de Mae Hong Son, Kanchanaburi et Phangnga, en Thaïlande; le karst de Maros à Sulawesi en Indonésie.

Les secteurs de Chiang Dao, de la Nam Lang et de Kanchanaburi sont plutôt montagneux. Le karst y est développé dans des calcaires permo-carbonifères parfois dolomités; la couverture pédologique silicatée d'origine détritique est relativement importante et tend à empâter le relief. Le karst à tourelles de Phangnga s'élève au dessus d'une plaine alluviale en bordure de mer. A Maros le karst, structuré par les nombreux corridors développés à la faveur de dykes de roches éruptives, présente une variabilité morphologique importante; ses calcaires d'âge éocène-miocène ont été en grande partie dégagés de leur couverture volcano-détritique.

2. Mesures de terrain et analyses en laboratoire

Les prélèvements sont effectués en flacon de polyéthylène de 125cc. Quatre paramètres sont mesurés sur place: la température (thermomètre à mercure au 1/5°C, ou numérique Quick-Novodirect à 0.1°C); le pH (pHmètre de terrain Aqua Data ou Bioblock à électrode époxy - tampons pH 6.87 et 4.01 - précision: +/- 0.01 pH); le TAC et le TH (coffrets d'analyse et procédure MERCK avec prise d'essai doublée (10cc au lieu de 5cc) et moyenne de 3 essais par analyse: AquaMerck Dureté carbonatée réf: 8048 - titrage acidimétrique, pipette à 0.2°d; AquaMerck Dureté totale réf: 8039 - titrage complexométrique, pipette à 0.2°d). Les mesures de pCO₂ de l'atmosphère (cavité et sol) sont effectuées à la pompe DRAEGER (tubes réactifs: anhydride carbonique pour teneurs de 0.1 à 6%, ou de 0.5 à 10%).

La conductivité est mesurée à 20°C (µS/cm). Sont analysés au laboratoire: les cations Mg, Na, K par spectrophotométrie d'absorption; Ca est obtenu par différence entre TH et Mg (ou chromatographie ionique); les sulfates par turbidimétrie ou chromatographie ionique, les nitrates et la silice par colorimétrie et les chlorures par colorimétrie ou potentiométrie. Sont calculés: HCO₃ à partir du TAC; la minéralisation totale (somme des concentrations des solutés); l'erreur de balance ionique B en % (différence entre la somme des cations et celle des anions - en meq/l - divisée par leur somme); la pCO₂ en % (pression partielle équilibrante de CO₂); le dpH différence entre le pH mesuré et le pH à l'équilibre (pour une eau à chimisme calco-carbonaté). Le calcul des équilibres chimiques est réalisé avec le programme SOLUTEQ au Laboratoire de Moulis (pCO₂, dpH, B, minéralisation). L'imprécision de certaines mesures ou les différences entre méthodes d'analyse qui n'ont pas été toujours les mêmes de 1985 à 1996 peuvent masquer ou décaler les variations naturelles faibles et donc rendre plus délicate l'interprétation de certains résultats.

3. Comportement des variables

La balance ionique est < 10% pour 90% des échantillons, mais < 5% dans 50% seulement des cas; elle est en général

positive: le déficit d'anions peut être pour partie imputé à une sous-estimation des sulfates (séries C à L).

Les températures sont représentatives du climat: voisines de 21 à 22°C dans le nord de la Thaïlande, de 25 à 26°C à Phangnga et dans le karst de Maros.

A l'exception des eaux non carbonatées pour lesquelles le pH descend jusqu'à 3.2, les valeurs sont comprises entre 6.14 et 8.17. Ces variations ne peuvent être interprétées indépendamment des deux autres paramètres pCO₂ et dpH. Les plus faibles valeurs correspondent à de fortes pCO₂.

La minéralisation varie de 23 à 2125 mg/l avec une majorité des échantillons entre 100 et 400 mg/l. TH et TAC suivent les mêmes variations. Compte tenu des valeurs de pH, les bicarbonates s'identifient au TAC: de 8 à 486 mg/l. Calcium et magnésium, associés au travers du TH, représentent la contribution principale des cations à la minéralisation totale: 1.6 à 190 mg/l pour Ca, et 0.05 à 66.5 mg/l pour Mg dont l'importance est liée à une dolomitisation partielle comme le confirment les rapports Ca/Mg. Sauf pour l'échantillon J1, tout-à-fait particulier, sodium et potassium sont en faible quantité (resp. 0.15 à 8.5 mg/l et 0.12 à 6.7 mg/l); avec la silice (1.5 à 30.5 mg/l) ils représentent la composante exogène du chimisme des eaux. Les teneurs en chlorure, faibles, varient de 0.8 à 6 mg/l. Les sulfates sont compris entre 0.1 et 20.15 mg/l. Les nitrates sont marginaux, en général < 1 mg/l.

dpH et pCO₂: pour les échantillons dont l'analyse est complète et significative, les dpH varient entre -2.38 et 0.95, les pCO₂ entre 0.1 et 24.3%.

4. Interprétation

En dehors de l'examen direct des données, diverses méthodes ont été utilisées pour dégager les corrélations entre variables et caractériser les échantillons. De façon générale on retrouve les fortes corrélations entre HCO₃ et Ca d'une part, pH et pCO₂ d'autre part, directement liées à l'équilibre calco-carbonique, et celles reliant Na, K et SiO₂ qui représentent l'influence des sols ou des terrains non carbonatés. Ainsi le tableau 2 donne les valeurs des coefficients de corrélation obtenus par analyse sur 30 sites de Thaïlande. L'ACP correspondante permet d'expliquer 82.5% de la variance totale sur les trois premiers axes principaux. Le premier (36.4%) oppose HCO₃ et Ca à Na, K, SiO₂ et différencie la composante chimique acquise et évoluant en surface (périphérie non carbonatée ou couverture détritique superficielle) de celle acquise à l'intérieur de l'aquifère. Le second (29.6%) oppose le pH et la pCO₂ et représente donc le facteur CO₂: il conduit à différencier les eaux riches en CO₂ provenant de la zone noyée (H2, A17, C2) ou de percolations lentes (A4, A38), des eaux plus pauvres d'écoulements de surface allochtones (C14, B64, B52, B53) ou de percolations rapides (C11). Le troisième (16.5%) est lié à Cl et Mg: l'évolution du chimisme et l'origine de ces deux ions étant a priori différente, il semble que cet axe puisse rendre compte de l'éloignement du domaine maritime: on retrouve en effet une diminution des teneurs en chlorure de Phangnga à Chiang Dao.

	pH	HCO3	Cl	SO4	Ca	Mg	Na	K	SiO2	pCO2	dpH
pH	1.000										
HCO3	-0.616	1.000									
Cl	0.483	-0.285	1.000								
SO4	0.319	-0.245	0.419	1.000							
Ca	-0.507	0.922	-0.376	-0.405	1.000						
Mg	-0.375	0.557	0.237	0.275	0.230	1.000					
Na	-0.065	-0.359	0.368	0.400	-0.608	0.301	1.000				
K	-0.121	-0.306	0.025	0.309	-0.429	-0.041	0.666	1.000			
SiO2	-0.204	-0.210	-0.094	0.575	0.410	0.148	0.666	0.747	1.000		
pCO2	-0.732	0.719	-0.167	0.006	0.495	0.750	0.063	-0.013	0.141	1.000	
dpH	0.585	0.222	0.200	-0.018	0.352	-0.029	-0.588	-0.546	-0.608	-0.205	1.000

Tableau 2 - Coefficients de corrélation entre variables (sur 30 sites de Thaïlande)

Globalement, en dehors d'eaux très peu minéralisées de terrains non karstiques (B1, B61, B62, B63, < 80 mg/l), on peut distinguer trois groupes aux limites floues:

- Le premier (106 - 195 mg/l) correspond à des écoulements d'origine allochtone qui se chargent peu à leur traversée du karst: pertes (A7, B64, C14) et résurgences (B53, B52, I2, H1, D1) en général sous-saturées, ou à des eaux de percolation rapide (C11).
- Le 2ème groupe (217 - 400 mg/l) est représenté par des eaux de percolation plus lente moyennement minéralisées (B17, B54, D2, H3), et la plupart des écoulements de la zone de transfert horizontal (A2, A34, B6, B7, B14, B51, C9, C10, I1, I3, J3); on y rencontre également quelques fortes pCO₂ généralement associées à des dpH négatifs (A40, B67, F2, F3).
- Le dernier groupe est constitué des eaux les plus minéralisées (405 à 681 mg/l): percolation lente, ruissellement de paroi ou gouttage de stalactites (A4, A38), eaux de circulations et émergences au niveau du karst noyé (C2, A17, B59, B60, B66, F1, H2, J2), présentant de fortes pCO₂, associées souvent à la présence d'un épais couvert pédologique. Ce sont des eaux à temps de séjour long.

5. Discussion

Sur Phangnga nous recoupons les résultats de PITMAN (1978) qui identifie 3 types d'eau dont des lessivats de sol très sous-saturés à forte teneur en CO₂ et faiblement minéralisés: nos écoulements de surface dérivent de cette catégorie par perte du CO₂ excédentaire, diminution du dpH et enrichissement en carbonates. En Indonésie BALAZS (1968) analyse près d'une quarantaine de sources; nos mesures sur le karst de Maros et Sumatra sont voisines des siennes.

Des mesures conjointes de pCO₂ de l'atmosphère ont été faites au droit de sites prélevés; elles conduisent au constat général suivant: a/ les plus fortes teneurs se rencontrent là où de fortes pCO₂ existent dans l'eau, et en présence d'un couvert pédologique épais; b/ à quelques exceptions près, la pCO₂ de l'eau est égale ou supérieure à celle de l'atmosphère qui la surmonte; c/ lorsque il existe un gradient mesurable, les pCO₂ atmosphériques sont plus fortes près de l'eau.

On retrouve la différenciation régionale avancée par DEHARVENG (1986, 1987) entre les karsts à couvert pédologique limité ou squelettique (Phangnga, Maros), et ceux à couvert détritique épais (Nam Lang et Kanchanaburi) avec des valeurs de pCO₂ plus fortes dans ces derniers ("cavités à CO₂"). Aucune corrélation avec la pluviométrie n'a été notée. La comparaison avec d'autres données publiées, notamment par RENAULT (1979), montre qu'il n'y a pas de différence dans la gamme des teneurs mesurées pour une pluviométrie plus faible. Les travaux de CROWTHER (1983), menés sur des sols karstiques de Malaisie, mentionnent également l'influence déterminante (mais non unique) de la couverture pédologique dans la disponibilité du CO₂ au niveau du sol.

6. Conclusion

L'eau, moteur de la karstification est aussi vecteur d'information, et par ce qu'elle transporte en solution elle garde la trace de son origine et de son histoire. Cet aspect est particulièrement important pour l'approche des karsts de régions difficiles d'accès. C'est ainsi que le suivi individualisé d'une crue ou un échantillonnage extensif de sites représentatifs permet d'apporter la base de données quantitatives qui fait trop souvent défaut à certains travaux et permettrait de nuancer certaines interprétations. Nos résultats restent à développer mais il est possible d'en dégager les points suivants:

- La mise en évidence de plusieurs types d'eau marquées par leur origine et leur histoire.
- L'absence de différenciation par les caractères hydrochimiques et en particulier le CO₂, de ces karsts avec ceux des régions tempérées.
- L'importance de la nature de la couverture pédologique dans la limitation de la diffusion vers l'atmosphère du CO₂, rendant celui-ci plus disponible pour son transfert vers la base de l'aquifère par l'infiltration rapide.

En ce qui concerne les implications karstogénétiques, qu'il n'a pas été possible de développer ici, il semble enfin que rien ne permette d'affirmer que l'évolution des karsts tropicaux de ces régions - dont certains sont d'ailleurs des paléokarsts - soit plus rapide qu'ailleurs.

Références

- BAKALOWICZ, M. 1979. Contribution de la géochimie des eaux à la connaissance de l'aquifère karstique et de la karstification, Thèse Doct. Sciences, Université P. et M. Curie. 269 p.
- BALAZS, D. 1968. Karst regions in Indonesia. Karst-ès Barlangkutatás: 3-61.
- BROUQUISSE, F.; BAKALOWICZ, M. 1986. 16 - Hydrogéochimie. In Expédition Thaï-Maros 85. APS Toulouse: 136-143.
- BROUQUISSE, F.; DALGER, D. 1987. 8 - Hydrogéochimie. In Expédition Thaï-Maros 86. APS Toulouse: 85-110.
- BROUQUISSE, F.; DALGER, D.; BAKALOWICZ, M. 1988. Résultats hydrogéochimiques des expéditions Thaï-Maros 86 et Thaï 87. In Expéditions de l'APS en Asie du sud-est, travaux scientifiques-1. APS Toulouse: 5-16.
- BROUQUISSE, F.; DALGER, D.; DEHARVENG, L. 1992. 6 - Sulawesi: résultats scientifiques. In Expédition Indonésie 90. APS Toulouse: 83-94.
- BROUQUISSE, F. 1995. 7 - Quelques données hydrogéochimiques et climatologiques. In Expédition Sumatra 93. APS Toulouse: 45-52.
- CROWTHER, J. 1983. Carbon dioxide concentrations in some tropical karst soils, West Malaysia. *Catena*, 10:27-39.
- DEHARVENG, L.; BEDOS, A. 1986. 17 - Gaz carbonique. In Expédition Thaï-Maros 85. APS Toulouse: 144-152.
- DEHARVENG, L. 1987. 6 - Nouvelles données sur le gaz carbonique des sols et des cavités de Thaïlande et de Sulawesi. In Expédition Thaï-Maros 86. APS Toulouse: 97-110.
- PITMAN, J.I. 1978. Carbonate chemistry of groundwater from tropical tower karst in South Thailand. In *Water Resources Research*, vol. 14 N°5 (1978).
- RENAULT, P. 1979. Mesures périodiques de la pCO₂ dans les grottes françaises au cours de ces dix dernières années. In Actes du symposium international sur l'érosion karstique, Aix-Marseille-Nîmes 10-14 sept. 1979: 17-33.

Remerciements

La collecte et l'analyse des données a été réalisée avec l'aide du Laboratoire Souterrain du CNRS de Moulis, du Laboratoire d'Hydrobiologie de l'Université P.Sabatier de Toulouse et de nombreux collègues et amis, en particulier M.BAKALOWICZ, D. D'HULST, C. MUR, D. DALGER, L. DEHARVENG, A. BEDOS, R.BROUQUISSE, D.RIGAL, Le. DEHARVENG, P.LECLERC, Me DEOTTO de la société MERCK.

Simulation of the evolution of maze caves

Torsten Clemens, Dirk Hückinghaus, Martin Sauter, Rudolf Liedl, Georg Teutsch
University of Tübingen, Applied Geology, Sigwartstr. 10, D-72076 Tübingen, Germany

Abstract

The development of cave systems in carbonate rocks depends on a variety of boundary and initial conditions. Among the cave systems, two main types of geometries can be distinguished: the dendritic and maze pattern. A numerical model has been developed capable of modeling the genesis of karst systems in complex geological environments. It is applied to simulate the development of the above mentioned two different types of cave geometries.

The results confirm that a prerequisite for the development of maze caves is evenly distributed recharge (White 1969). However more important for the development of maze caves is that flow through the system is restricted by an overlying less conductive horizon, e.g. a sandstone caprock. Thus the feed back mechanism of higher flow rates leading to higher dissolution rates and therefore the preferential development of a small number of tubes does not dominate the evolution of the karst aquifer. This hydraulic restriction furthers the development of other conduits also to achieve a significant diameter.

Zusammenfassung

Die Entwicklung von Höhlensystemen hängt von vielen Anfangs- und Randbedingungen ab. Zwei grundlegende Geometrien von Höhlen können unterschieden werden: dendritische Höhlen und Netzköhlen. Es wird ein numerisches Modell vorgestellt, das es ermöglicht, die Genese von Karstaquiferen mit komplexen geologischen Strukturen zu simulieren. Es wurde eingesetzt, um die steuernden Faktoren, die die Genese von Netzköhlen bestimmen, zu untersuchen.

Die Ergebnisse bestätigen, daß eine Voraussetzung für die Entwicklung von Netzköhlen eine gleichmäßig verteilte Grundwasserneubildung ist (White 1969). Wichtiger für die Entwicklung von Netzköhlen ist die Beschränkung des Durchflusses durch einen geringer durchlässigen Horizont, wie z.B. einen den Kalkstein überlagernden Sandstein. Während in Systemen ohne überlagernde Sandsteinschicht der Fließwiderstand der Röhren durch die Erweiterung abnimmt, bestimmt in Systemen mit überlagernder Sandsteinschicht der k_f -Wert des Sandsteines die Fließgeschwindigkeit in den Röhren. Die positive Rückkopplung der Zunahme des Durchflusses auf die Fließgeschwindigkeit in den Röhren und die damit erhöhten Lösungsraten ist dadurch unterbrochen und Röhren mit kleineren Durchmessern werden schneller erweitert als Röhren mit größeren Durchmessern: somit entstehen Netzköhlen.

Introduction

The mapping of more than 20 000 km of caves (COURBON & CHABERT, 1986) in the last decades shows that two dominant geometries of caves can be distinguished: a dendritic and a maze pattern (PALMER 1975, PALMER 1991). The dendritic pattern is characterised by conduits that converge in downflow direction whereas the maze pattern consists of a labyrinth of intersecting passages.

The genesis of a dendritic cave requires a strong selective enlargement of some of the numerous initial fractures of a karst aquifer. On the other hand labyrinth caves should be the result of simultaneous enlargement of fractures. A conceptual model for the development of maze caves was introduced by WHITE (1969). He found that limestones which are sandwiched in insoluble rock exhibit the typical network pattern. WHITE (1969) concluded that the lack of concentrated recharge from overlying beds causes the development of the maze caves in the limestones.

PALMER (1975) distinguished different processes for the development of maze caves. According to PALMER (1975) maze caves develop due to diffuse infiltration from an overlying insoluble caprock, beneath isolated hills of limestone or by floodwater recharge. The most of the investigated maze caves (75%) are capped by thin permeable sandstone (PALMER 1991). Another theory of maze cave development states that mixing of thermal and meteoric water beneath a sandstone lead to the development of tube networks (BAKALOWICZ et al., 1987; FORD & WILLIAMS, 1989).

Besides from the conceptual models about cave genesis the enlargement of fractures was analysed mathematically. Coupling the flow and dissolution kinetics WEYL (1958) concluded that the penetration distance of water to reach

saturation is short in comparison to the length of the flow path in natural catchments. This problem of enlargement of fractures far from the water inlet was solved by WHITE (1977). WHITE (1977) concluded that, due to the reduction in the dissolution rates close to equilibrium, the fractures will also be enlarged in the downgradient portion.

DREYBRODT (1988, 1990) and PALMER (1991) developed one-dimensional numerical models which included the reduced dissolution rate close to the equilibrium. These models were used to determine the sensitivity of various parameters for the enlargement of a single fracture. A two dimensional tube network model for the simulation of laminar flow conditions was introduced by GROVES & HOWARD (1994). The results of the simulations show that a strong selective enlargement of initial preferential flow paths occurs. The model results of HOWARD & GROVES (1995) lead to a formation of maze caves if large initial tube diameters or high hydraulic gradients are specified.

A numerical model coupling the flow in the fissured system of a karst aquifer with the flow in the conduit system was developed by CLEMENS et al. (1996). The model CAVE (Carbonate Aquifer Void Evolution) simulates the evolution of carbonate aquifers under a variety of boundary conditions and laminar as well as turbulent flow conditions. In the study presented here the development of maze caves is simulated using a two layer model. The upper layer represents an insoluble caprock and the lower layer the limestone formation.

Theory

Flow in carbonate aquifers occurs in a less conductive, high storage fissured system as well as in the highly conductive, low

storage conduit system. In order to calculate the flow in carbonate aquifers the flow is separately calculated in the small fissures and in the conduit system. The flow in the fissured system is simulated using a continuum model and the flow in the fractures with larger apertures by a tube network model. Both systems are coupled by a linear exchange term. The tubes are enlarged by dissolution of limestone. Thus the hydraulic heads in the system must be calculated after every time step in order to obtain the new flow velocities in the tubes.

The flow in the fissured system is described mathematically by the groundwater flow equation (HUYAKORN et al. 1983)

$$\frac{\partial}{\partial x} \left(T \frac{\partial h_c}{\partial x} \right) + \frac{\partial}{\partial y} \left(T \frac{\partial h_c}{\partial y} \right) = S \frac{\partial h_c}{\partial t} - \gamma - r \quad (1)$$

where h_c is the hydraulic head in the continuum, T and S are the transmissivity and storage coefficient respectively, γ is the volumetric rate of fluid transfer from the fissured system to the pipe network per unit area, and r is the groundwater recharge per unit area. For the calculation of the flow in the tube network Kirchhoff's rule is applied, stating that the sum of inflow and outflow at any node i of the network is zero (2):

$$0 = \sum_{j=1}^{n_i^{turb}} Q_{ij} + \sum_{j=1}^{n_i^{lam}} Q_{ij} + R_i + \Gamma_i \quad (2)$$

with R_i the direct recharge at node i into the pipe network and n_i^{lam} and n_i^{turb} the numbers of the tubes with laminar and turbulent flow connected to node i . Q_{ij} is the flow through the tubes connecting nodes i and j and can be either laminar or turbulent. For laminar flow the Hagen-Poiseuille formula is used, while turbulent flow is calculated using the Colebrook-White equation. The exchange flow rate Γ_i between the fissured system and the tube network is calculated by

$$\Gamma = \alpha_{ex,i} (h_{c,i} - h_{t,i}) \quad (3)$$

where $\alpha_{ex,i}$ is the exchange term, $h_{t,i}$ is the hydraulic head in the tube network at the node i and $h_{c,i}$ is the hydraulic head in the continuum at the node i .

Calcite dissolution far from equilibrium has been investigated by a number of authors (e.g. BERNER & MORSE 1974, PLUMMER & WIGLEY 1976). BUHMANN & DREYBRODT (1985) showed that the dissolution far from equilibrium can be approximated by a first-order rate law. However, close to the equilibrium the dissolution rate is reduced significantly and can be described by a fourth-order rate law (PLUMMER & WIGLEY 1976, SVENSSON & DREYBRODT 1992). The dissolution rate R is given by

$$R = k_n (c_{eq} - c)^n \quad (4)$$

where n is the reaction order, c_{eq} is the equilibrium concentration of calcium and k_n is the rate constant for the first-order or fourth-order reaction rate. For laminar flow, the value for $k_{1(lam)}$ is corrected in order to account for the diffusion of the species into the solution (DREYBRODT 1990). The flow of the water directly into the conduits is given by the vertical leakage and the head difference between the two layers. The vertical hydraulic conductance is multiplied by the dimensionless factor γ_{dir} (here $5 \cdot 10^{-4}$) in order to determine the part of the water flowing directly into the conduit system. This factor accounts

for the lesser cross section for the water flowing directly into the conduit system than from the upper into the lower layer.

Model Structure

In order to model the evolution of a maze cave a rectangular model domain, discretised into two layers, was used (Figure 1). The modeled domain measures 1050 m by 1350 m. The hydraulic conductivity of the upper layer is 10^{-5} m/s. The vertical leakance V_{Cont} is $5 \cdot 10^{-7} s^{-1}$ and a constant recharge of 400 mm/a is applied. Three sides of the upper layer are no-flow boundaries and at one side a constant head boundary is specified, representing a river. This configuration means that the water input as well as the water output are affected by the sandstone caprock.

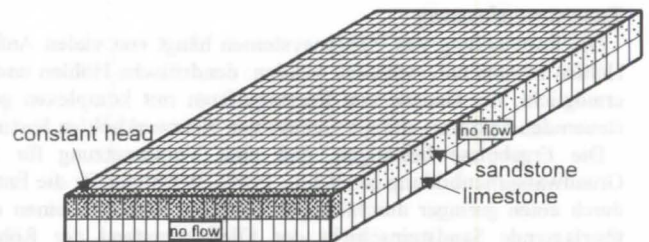

Figure 1: Two layer model with the limestone in the lower and sandstone caprock in the upper layer. The constant head boundary is specified in the upper layer, i.e. the water which flows through the limestone must cross the sandstone before it reaches the river.

A regular network is assumed in the lower layer (Figure 2). The initial diameter of the tubes connecting row 9, 10 and 11 (thicker lines in Figure 2) is 1 mm and 0.4 mm for all other tubes. The larger initial diameters were used in order to investigate whether an initial preferential flow path leads to the development of dendritic caves. The transmissivity of the lower layer is $10^{-4} m^2/s$, the thickness of the lower layer is 30 m and the coefficient of the linear exchange is equal to $10^{-5} m^2/s$. For the lower layer four no-flow boundaries are specified.

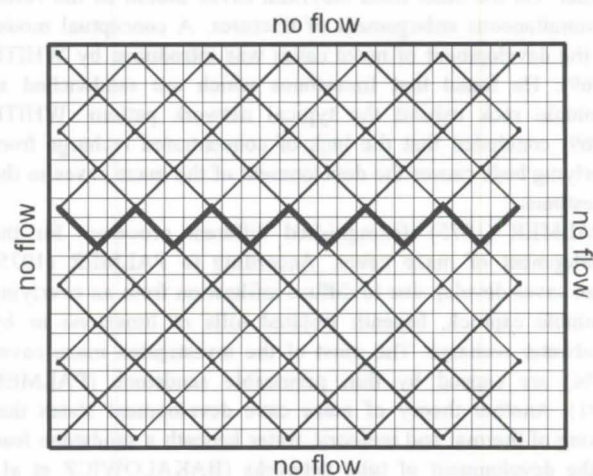

Figure 2: Geometry of the conduit system in the lower layer of the model domain. The initial diameters of the tubes connecting row 9, 10 and 11 are 1 mm and of the remaining tubes 0.4 mm.

It is assumed that the water within the fissured system is slightly undersaturated ($c=0.9 c_{eq}$). The water entering the conduit system from the upper layer is assumed to have a concentration of 0 mol/L of calcium. Higher concentrations of the water entering the conduit system from the upper layer or from the fissured system lead to longer periods of time necessary for the development of the conduit system but the geometry of the conduit system develops in the same way as for lower concentrations. The equilibrium concentration of calcium is $c_{eq} = 2 * 10^{-3}$ mol/L, the kinetic rate constants far from the equilibrium ($n=1$) are $k_{1(lam)} = 2.5 * 10^{-5}$ m/s, $k_{1(tur)} = 5 * 10^{-5}$ m/s. Close to the equilibrium the kinetic rate constant is ($n=4$) $k_4 = 1.2 * 10^{13}$ cm¹⁰ mol⁻³ s⁻¹, as suggested by DREYBRODT (1990). The change in the kinetics from the first-order to the fourth-order rate law is assumed to occur at $c/c_{eq} = 0.9$. The recharge data and the hydraulic parameters for the lower layer are derived from a karst aquifer system in SW Germany (SAUTER 1992).

Results and Discussion

The results of the simulations are depicted in Figures 3 and 4. Initially the tubes with the larger initial diameters are enlarged more rapidly than the other tubes (Figure 3). After 5500 years the enlargement rate of the tubes with the small initial diameters is higher than the enlargement rate of the tubes with the larger initial diameters. This set up leads to the development of a maze cave system as shown in Figure 4. The reason for this type of development is the low hydraulic conductivity of the overlying layer. This causes that the positive feed back mechanism of the enlargement of the tubes leading to higher flow velocities and accordingly higher dissolution rates not to take place.

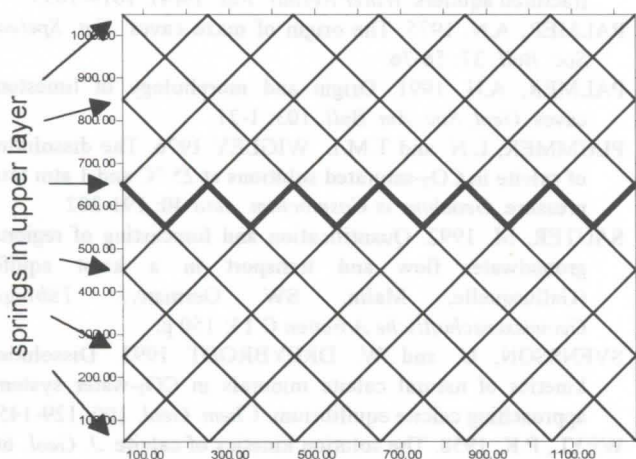

Figure 3: Geometry of the conduit system (lower layer) after 2500 years. The thicker lines indicate tubes with a diameter > 0.002 m.

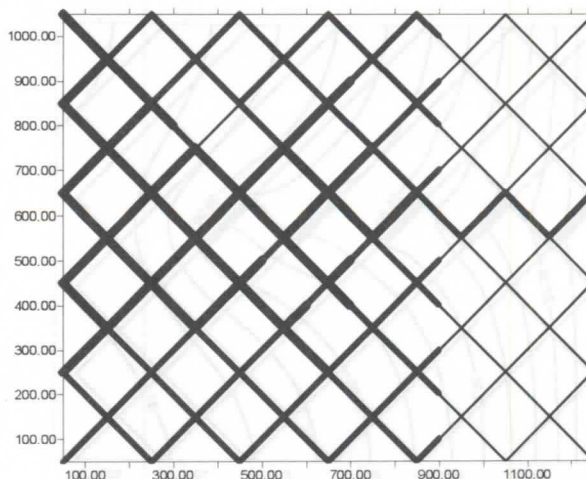

Figure 4: Geometry of the conduit system (lower layer) after 5875 years. The thickest lines indicate tubes with a diameter > 0.02 m.

In order to investigate the importance of the feed back mechanism addressed above, a simulation is performed using a one-layer model, i.e. without the caprock. In this model configuration all the recharge infiltrates into the limestone, i.e. there is no surface runoff. The geometry of the conduit system is shown in Figure 2 except that a constant head boundary is applied on the left hand boundary. Recharge is distributed uniformly, whereby 1 % of the total recharge is injected directly into the conduit system. For the above described model run with the caprock runoff is allowed and direct recharge increases from 0.004 % at the beginning of the simulation to 0.5 % at the end of the simulation depending on the drainage capacity of the conduits. The aquifer in the simulation without the caprock is assumed to be unconfined and the coefficient of the linear exchange term is equal to 0.0001 m²/s.

The results of the model run are displayed in Figures 5 and 6. The tubes with the higher initial parameters are enlarged more rapidly than the tubes with smaller initial diameters. Due to the highest hydraulic gradient in the tube adjacent to the constant head boundary this tube is the first one to experience turbulent flow conditions.

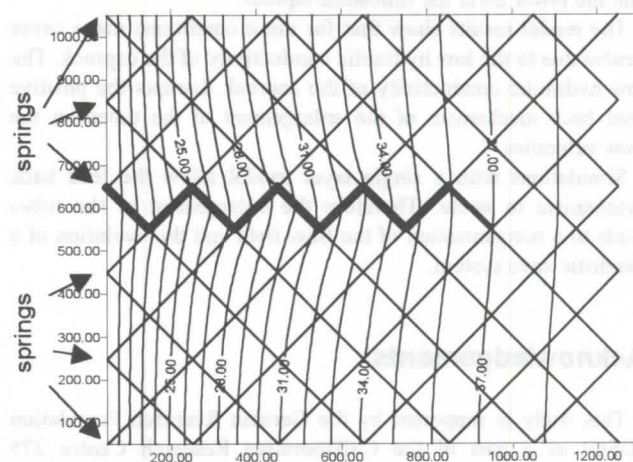

Figure 5: Geometry of the conduit system and heads in the fissured system after 2000 years. The thicker lines show tubes with a diameter > 0.02 m.

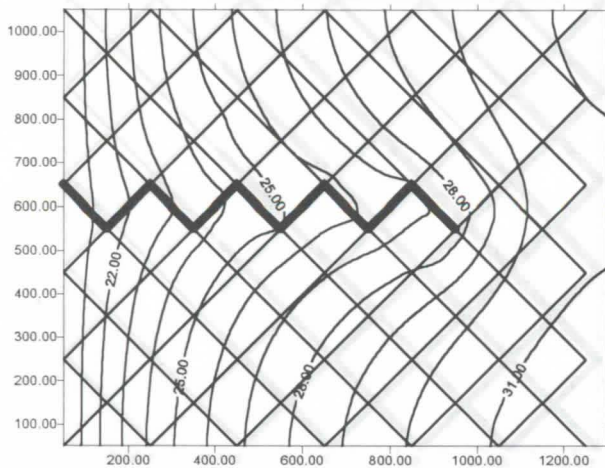

Figure 6: Geometry of the conduit system and heads in the fissured system after 2500 years. The thickest lines show tubes with a diameter > 0.2 m.

The low flow resistance of the enlarged tube causes the highest hydraulic gradient to be observed in the adjacent tube in upgradient direction. In that way the conduit system evolves in an upgradient direction. The continuous enlargement of the tubes change the flow field and lead to the development of a distinguished drainage area for the conduit.

The results of the model indicate that the uniform distribution of recharge beneath insoluble caprock is a prerequisite for the development of maze caves as suggested by WHITE (1969) and PALMER (1975). However we believe that even a more important factor could be the disrupting effect of the low conductive caprock on the flow-dissolution feed back mechanism. Further simulations will be conducted to analyse this in more detail.

Conclusions

The genesis of maze caves was investigated using a numerical model. The numerical model integrates the dissolution kinetics of calcite as well as the flow in the fissured and conduit system of a karst aquifer. A model domain consisting of two layers was chosen whereby the upper layer represents an insoluble caprock and the lower layer the limestone aquifer.

The model results show that for these conditions maze caves evolve due to the low hydraulic conductivity of the caprock. The low hydraulic conductivity of the caprock disrupts the positive feed back mechanism of the enlargement of the tubes on the flow velocities.

Simulations with a single layer model allow the feed back mechanism to occur. Therefore the enlargement of the tubes leads to a reorganisation of the flow field and the evolution of a dendritic cave system.

Acknowledgements

This study is supported by the German Research Foundation (DFG) as a part of the Collaborative Research Centre 275 (Sonderforschungsbereich 275) and by the European Union (Contract CEC EV5V-CT94-0471). The authors would like to thank Prof. Dreybrodt (University of Bremen) for helpful comments on the manuscript.

References

- BAKALOWICZ, M., FORD, D.C., MILLER, T.E., PALMER, A.N. and M.V. PALMER 1987. Thermal genesis of solution caves in the Black Hills, South Dakota. *Geol. Soc. Am. Bull.* 99: 729-738.
- BERNER, R.A. and J.W. MORSE 1974. Dissolution kinetics of calcium carbonate in sea water. IV theory of calcite dissolution. *Am. J. Science* 274: 108-134.
- BUHMANN, D. and W. DREYBRODT 1985. The kinetics of calcite dissolution and precipitation in geologically relevant situations of karst areas. 2. Closed systems. *Chem. Geol.* 53: 109-124.
- CLEMENS, T., HÜCKINGHAUS, D., SAUTER, M., LIEDL, R. and G. TEUTSCH 1996. A combined continuum and discrete network reactive transport model for the simulation of karst development. *IAHS Publ. no. 237*: 309-318.
- COURBON, P. and C. CHABERT 1986. Atlas des grandes cavités mondiales. *Union Internationale de Spéléologie, Fédération Française de Spéléologie*: 225 p.
- DREYBRODT, W. 1988. Processes in karst systems. *Springer, Berlin Heidelberg New York*: 288 p.
- DREYBRODT, W. 1990. The role of dissolution kinetics in the development of karst aquifers in limestone: A model simulation of karst evolution. *J. Geology* 98: 639-655.
- FORD, D.C. and P.W. WILLIAMS 1989. Karst geomorphology and hydrology. *Unwin Hyman, London*: 601.
- GROVES, G.G. and A.D. HOWARD 1994. Early development of karst systems: 1. Preferential flow path enlargement under laminar flow. *Water Resour. Res.* 30 (10): 2837-2846.
- HOWARD, A.D. and C.G. GROVES 1995. Early development of karst systems: 2. Turbulent flow. *Water Res. Research* 31 (1): 19-26.
- HUYAKORN, P.S., LESTER, B.H. and C.R. FAUST 1983. Finite element techniques for modeling groundwater flow in fractured aquifers. *Water Resour. Res.* 19(4): 1019-1035.
- PALMER, A.N. 1975. The origin of maze caves. *Nat. Speleol. Soc. Bull.* 37: 56-76.
- PALMER, A.N. 1991. Origin and morphology of limestone caves. *Geol. Soc. Am. Bull.* 103: 1-21.
- PLUMMER, L.N. and T.M.L. WIGLEY 1976. The dissolution of calcite in CO₂-saturated solutions at 25 °C and 1 atm total pressure. *Geochim. et Cosmochim. Acta* 40: 191-202.
- SAUTER, M. 1992. Quantification and forecasting of regional groundwater flow and transport in a karst aquifer (Gallusquelle, Malm, SW Germany). *Tübinger Geowissenschaftliche Arbeiten C* 13: 150 p.
- SVENSSON, U. and W. DREYBRODT 1992. Dissolution kinetics of natural calcite minerals in CO₂-water systems approaching calcite equilibrium. *Chem. Geol.* 100: 129-145.
- WEYL, P.K. 1958. The solution kinetics of calcite. *J. Geol.* 66: 163-176.
- WHITE, W.B. 1969. Conceptual models for carbonate aquifers. *Groundwater* 7: 15-21.
- WHITE, W.B. 1977. Role of solution kinetics in the development of karst aquifers. *Internat. Assoc. Hydrogeol. Memoir* 12: 503-517.

Periodic and aperiodic forcing of water flow through sodastraw stalactites (Choranche, Vercors, France)

Jean-Luc Destombes¹, Michel Cordonnier¹, Jean-Yves Gadat¹ and Jean-Jacques Delannoy²

1) Laboratoire de Spectroscopie Hertzienne, URA CNRS 249, Centre d'Etudes et de Recherches Lasers et Applications, Université des Sciences et Technologies de Lille, 59655-Villeneuve d'Ascq cedex, France. 2) Institut de Géographie Alpine, URA CNRS 903, Université Joseph Fourier, 17, rue Maurice Gignoux, 38031-Grenoble, France

Abstract

During the last few years, speleothems have appeared to be of increasing interest for high resolution paleo-environmental applications. Among the many parameters which govern the speleothem growth rate, the drip water discharge is of the uppermost importance.

Since May 1996, high temporal resolution flow rate measurements are carried out by the « drop counting » method on five stalactites located in the Choranche caves (Vercors, France). Even if the recording period is still too short for characterising long term evolution, recordings already show interesting periodic variations of the flow rate of 2 sodastraw stalactites. Preliminary Fourier analysis clearly show the existence of at least two major forcings with diurnal and semi-diurnal periods, confirming recordings obtained more than 20 years ago in a small cave of the same area. Possible relations with earth and atmospheric tides are discussed. A preliminary analysis of a spectacular « stalactite swelling » is also presented.

Résumé

Au cours des dernières années, les spéléothèmes sont apparus comme des outils susceptibles de fournir des informations paléoenvironnementales à très haute résolution temporelle. Parmi les nombreux facteurs qui gouvernent leur taux de croissance, le débit de l'alimentation en eau est clairement de première importance.

Depuis mai 1996, des mesures de débit sont menées par comptage de gouttes sur 5 stalactites des Grottes de Choranche (Vercors, France). Même si la période d'étude est encore trop courte pour une étude des tendances à long terme, les enregistrements mettent d'ores et déjà en évidence des variations périodiques intéressantes. L'analyse de Fourier fait clairement apparaître une modulation périodique diurne et semi diurne du débit de 2 fistuleuses, confirmant des observations faites il y a plus de 20 ans dans une cavité de la même région. Les relations possibles avec les marées terrestres et atmosphériques sont discutées. Une analyse préliminaire d'une spectaculaire « crue de stalactites » est également présentée.

1. Introduction

There is currently a growing interest in the study of the speleothems considered as a memory of the paleo-environmental conditions over the continents. Speleothem abundance is indeed closely related to climatic and environmental factors such as temperature, water availability, atmospheric and soil CO₂ concentration, presence of an active vegetation cover and insolation (GASCOYNE, 1992; HARMON *et al.*, 1978; HENNIG *et al.*, 1983; MAIRE & QUINIF, 1988; GORDON *et al.*, 1989; LAURITZEN *et al.*, 1990; BASKARAN & KRISHNAMURTHY, 1993; SZABO *et al.*, 1994; GOEDE, 1994; BAKER *et al.*, 1995; GENTY & QUINIF, 1996; LAURITZEN, 1996a, and references therein). Moreover, KASHIWAYA *et al.* (1991) showed unambiguously that global climatic changes have been recorded in the speleothem growth in the United Kingdom.

As part of the search for a transfer function between the environmental conditions and the physico-chemical, climate related signals potentially recorded in speleothems (growth rate, morphology and petrography, isotopic ratios, tephras, dust, pollen content, concentration of trace elements and organic compounds, ...), a good knowledge of the depositional mechanisms of the modern underground calcite formations is clearly needed. Among the various parameters which govern the growth of a speleothem and depend directly on the climate, the amount of seepage water available is of first importance. To get insight in the growth of modern speleothems, the water flow rate of 5 stalactites is presently studied with a high temporal resolution in the Coufin cave (Choranche, Vercors, France) by the technique of « drop counting ». This cave is indeed a very favourable site for the observations of alpine karstic

phenomena and several studies of the present and past calcite deposits are currently under way by various spectroscopic methods (see two other communications by PERRETTE *et al.* at this Colloquium). Comparison between microscopic (fissure network) and macroscopic (rivers) hydrology will be possible since a measurement station (pH, water resistivity, river discharge, temperature) is now implemented in the cave and will be soon completed with a meteorological station installed on the surrounding plateau.

After a short description of the Coufin cave, we will present the method and the experimental set up. The analysis of the preliminary results will be focused on a spectacular « stalactite swelling », and on diurnal and semidiurnal variations. These latter ones appear during the summer period on 2 sodastraw stalactites confirming the observations made more than 20 years ago in a small cave of the same geographical area.

2. Presentation of the Coufin cave

The touristic Coufin cave opens in the NW part of the Vercors at an altitude of 581 m, down below the « Cirque de Choranche » cliffs, a vast amphitheatre formed of urgonian limestones, 200 to 300 m thick, surrounding the impermeable hauterivian marls. The visited part of the Coufin cave is only a small part of one of the two major cave systems which drain the « Massif des Coulmes » anticlinal, the Gournier system and the Coufin-Chevaline system with total developments of more than 29 km and depths of 411 m. This massif of moderate altitude (around 800 m), covered with oak- and beech groves is characterised by a conekarst related to a hot and wet pliocene period (DELANNOY *et al.*, 1988; DELANNOY, 1991). It has been deeply cross cut by the Bourne river (present altitude 300 m)

during the quaternary era. The underground networks develop at the contact between the urgonian limestones and the hauterivian marls. Recent studies (DELANNOY, 1997) have shown the existence of two types of networks, a suspended one

that the lower galleries are contemporary with the quaternary climatic episodes while the vast higher galleries are related to a paleo-drain of pliocene age (DELANNOY *et al.*, 1988 ; DELANNOY, 1991). The amazing diversity of speleothems of the Coufin cave (especially a great number of delicate sodastraw stalactites up to 3 m long) were formed during quaternary interstades.

Owing to the huge number of available stalactites, choosing five of them for the present study appears to be like a « poker stroke ». Nevertheless two sodastraws, with moderate flow rate at the time of the decision, were chosen according to the previous 1969-1971 summer records which were carried out on this type of stalactite and showed up clear semi-diurnal oscillations (figure 1). The three others are more conventional stalactites which are associated with stalagmites and/or flowstones. They are all located between 20 and 90 m from the cliff, *i.e.* within the decompression zone.

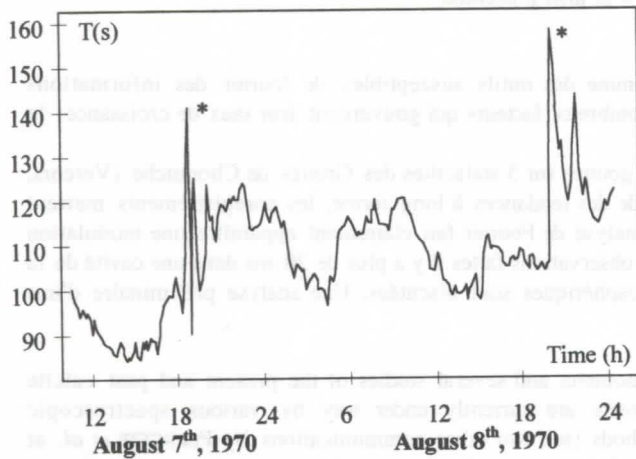

Figure 1 : Example of the semi-diurnal oscillations observed on the flow rate of a sodastraw (Grotte du Sourcier, Sainte Eulalie-en-Royans, Drôme) during summer 1970. *T* (in s) is the mean time between two drops. *T* is then inversely proportional to the flow rate. Stars indicate the strong perturbations induced by nearby thunderstorms, which were dry at the cave location.

3. Principle of the method and experimental set-up

The easiest way to measure the temporal variations of the stalactite flow rate with a high temporal resolution is to measure the time interval between two successive drops. This is the technique which one of us used for obtaining the 1969-1971 recordings (figure 1). It has been later used in the Coufin cave (DELANNOY, 1986) and is currently working elsewhere (LAURITZEN, 1996b ; GENTY *et al.*, 1996). The fundamental requirement of this method is that the volume of the drops is independent of the flow rate.

The problem of determining the volume of a pendant drop has been the subject of many investigations. Empirical and semi theoretical formula giving the volume of primary drops detaching from tubes in a quasi static experiment are available (TATE, 1864 ; RAYLEIGH, 1899 ; HARKINS & BROWN, 1919 ; FORDHAM, 1948 ; GARANDET *et al.*, 1994). However, the study

of syngenetic origin with big dimensions, and a smaller paragenetic one still active. Morphological studies and dating of the sediment fillings show

of the dynamics of drop formation (*i.e.* when the flow rate is not vanishingly small) is much more recent and is still actively investigated both experimentally (PEREGRINE *et al.*, 1990 ; SHI *et al.*, 1994) and theoretically (SCHULKES, 1994 ; EGGERS, 1995 ; ZHANG & BASARAN, 1995 ; and references therein). From these works, the formation of a drop can be described as follows : during the growth process, the volume of the drop hanging from the stalactite increases according to the flow rate of the feeding water and the geometry of the drop slowly evolves to pear-shaped. Once a critical volume is exceeded, the evolution becomes much more rapid, and just before the bifurcation, a spherical drop connected to the water remaining in the stalactite by a conical thread is formed. The rapid increase of the length of the thread leads to a break which releases a free drop called the primary drop. However, one or more satellite drops can be produced by dynamical effects as the remaining water filament retracts after the rupture. The details of these events critically depend on the water flow and at very high flow rate chaotic behaviour can even be observed (SHAW, 1984 ; WU *et al.*, 1989 ; DREYER & HICKEY, 1991). The dependence of the drop volumes with the flow rate has been experimentally studied by ZHANG & BASARAN (1995). According to their results, the volume of a primary drop of pure water is nearly independent (within 5%) of the flow rate as soon as this one is lower than about 1 drop/s. In these conditions, the volume of the satellite drops is less than 2.10⁻³ of the primary drop volume. It can be then considered that the measurements are quantitative with an accuracy of ~ 5%. It means that the measurement of the time interval between two drops could be converted into flow rate measurement. However, as the volume of a drop depends on the unknown diameter of the stalactite tip (TATE's law), it could be measured only by volume calibration. This has not yet been done and we present directly the mean period *T* versus time, *T* being of course inversely proportional to the flow rate.

Drops are detected by their impact on detectors positioned under the stalactites of interest at a distance from about half a meter to several meters. Each sensor consists of a piezoelectric gauge measuring the shock-induced deformation of a thin circular plastic membrane mounted on top of a flat hollow watertight container. These detectors are suitable for remote measurements because they do not require any power supply and they are insensitive to the specific environment of a cave. Output signals of the order of 100 mV are directly transmitted over ~100 m through ordinary cables to a distant acquisition system located in the cave itself, in a wood box close to a mains plug. After amplification, the damped sine wave delivered by a detector after a drop falls on its surface is converted into a TTL pulse as soon as its amplitude becomes higher than an adjustable threshold defining the sensitivity of the detection. This sensitivity is adjusted according to the strength of the drop impact which depends on the height of the fall. Changes in the logic state are detected using the centronics port of a personal computer (PC). The PC printer port is indeed an inexpensive platform providing eight TTL outputs, five inputs and four bi-directional leads for implementing projects dealing with peripherals. The signals delivered by the detectors are applied to the inputs which correspond to the status leads from the printer (BSY, /ACK, PE, SELECT, /ERROR) and can be fetched by reading the five most significant bits of the status port. Note that TTL outputs can be used to extend the number of

detectors by multiplexing the inputs. A program has been developed to register each event and to evaluate the mean period T between two drops, averaged over a period of time Δt predefined by the user. The acquisition system has been carefully designed to avoid the loss of data in case of mains failure. Data are referenced in time, stored on a hard drive and regularly gathered into a distant database. For this work, a PC 386SX16 was handling five detectors at an individual maximal counting speed set to ~ 5 drops/s.

4. Data analysis

Owing to the principle of the method, the averaging time Δt has to be chosen according to the lowest flow rate expected for the stalactites. First chosen as 3 min, it has been for example necessary to increase it to 6 min to take into account the drying during autumn. In any case, after some months of recording, such short averaging durations produce a huge number of data points which are handled with a home made database and a commercial grapher. Owing to the lack of place we do not give here the whole recordings which will be presented on our poster and we focus on two particular phenomena clearly observed in our recordings: the transient response of the stalactites following a swelling, and a periodic modulation of the flow rate.

Transient response following swelling

On 7th and 8th of July 1996, very heavy rains were observed on the Vercors and caused important floods and damages especially on the Bourne river but also in caves like the Gouffre Berger, the Trou qui Souffle (LISMONDE, 1996), or the Coufin cave itself. Unfortunately the river discharge measurement station was not yet operating at this time. On July 7th, the Autrans and Rencurel meteorological stations, distant from the Coufin cave basin by not more than 18 km and situated at about the same altitude, recorded 168 and 115.4 mm respectively. July 8th still showed important precipitations with 58 and 72.5 mm respectively. These two highly rainy days followed three days of moderate rain (a total of 37 and 24.3 mm respectively, for the July 4th, 5th and 6th) which themselves followed a relatively dry period (12.4 and 13.7 mm respectively during the 12 previous days) (figure 2). A completely dry period started after these two rainy days and lasted for more than two weeks. Such a situation where heavy rains are concentrated on a short period of time and are followed by a dry period is clearly ideally suited to study the response of the fissure network to a pseudo-transient excitation.

All the 4 sensors running during this period clearly detected the arrival of a swelling. The behaviour of the two sodastraws (stalactites 3 and 5) was especially impressive with a very fast increase of the water flow (figure 2). Unfortunately, sensor 3 was out of order immediately after the beginning of the swelling because it has been shifted by an important river overflow. In the case of stalactite 5, the swelling feature appeared as a strong dip in a regularly increasing curve. Fitting of this curve showed that the long term flow rate evolution was very well represented by an exponential law, with a time constant of 26.4 days which then represents the characteristic time for draining the fissure network which feeds this stalactite. This is the result expected for the draining of a reservoir in a laminar regime. The onset of the stalactite swelling was very sharp and the transition from « normal » flow to maximum flow rate, which follows approximately an exponential law, appeared to be especially short, about 8 hours. The maximum delay between this onset and the beginning of the rainy days

was about 40 hours, the uncertainty coming mainly from the low temporal resolution of the rain data (1 day). The return to the « normal » flow rate was also well timely definite and lasted less than 5 hours. The total duration of the high water flow rate was about 30 hours, shorter than the rain duration and also very short compared to the characteristic draining time.

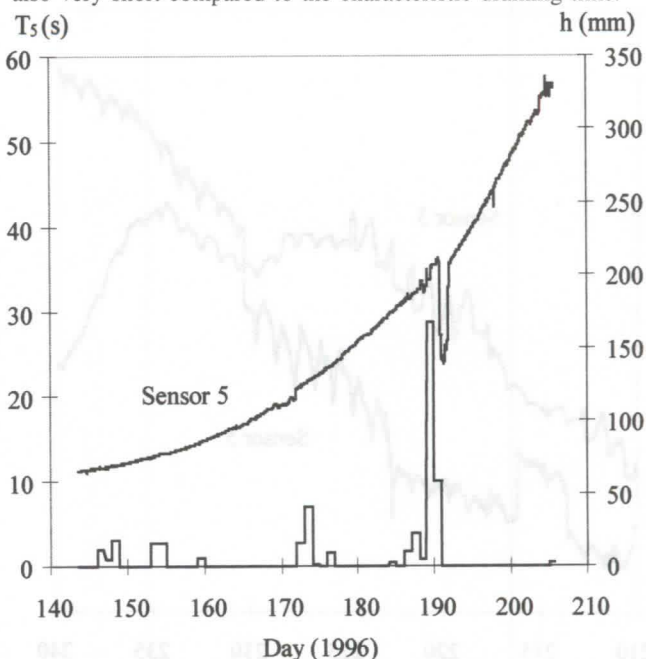

Figure 2: Recording of the flow rate of sodastraw 5, from May 28th to July 24th 1996 showing the swelling feature of July 8th. T_s (in s) is the mean time between two drops, averaged over 3 minutes. T_s is then inversely proportional to the flow rate. Rain data (h in mm) are from the Autrans meteorological station.

The recordings of the two other stalactites also unambiguously indicated the time of the swelling: the flow of the stalactite 4, already very fast ($T_4 \cong 0.5$ s) became nearly continuous within less than 10 hours and stayed at this high discharge for about 3 days. Stalactite 1 recording definitely showed a discontinuity at the same time but with an amplitude which did not exceed that of the other discontinuities which seem to be a characteristic of this stalactite. Note that such discontinuities are actually observed more or less often in all the recordings (see for example sensor 5 on figure 3); they are characterised by very steep rising and falling edges which occur in less than the averaging time, *i.e.* less than 3 minutes.

Semidiurnal and diurnal variations

Similarly to what is observed in some types of aquifers (RITZI *et al.*, 1991), the response of the water flow through karstic microfissures under periodic forcing can contain informations on the fissure network properties. As shown on figure 1, such a modulation of the flow rate of a sodastraw were obvious in the summer recordings of 1969-1971 (DESTOMBES, 1971). The period was close to 12 hours and the variations could represent as high as 40% of the mean flow rate. At that time however, the duration of the recording period (< 1 month) was too short to allow any grounded interpretation.

Figure 3 shows that such periodic variations are also observed on the two sodastraw of the Coufin cave. However, their amplitudes are much weaker, in the range of 3-6 %. After baseline subtraction, a Fourier analysis was performed on the two sets of data and gave evidence for two major forcings with

periods of $23.8(\pm 0.60)$ hours and $12.02(\pm 0.20)$ hours, with an amplitude ratio of 2.3. This result contrasts with the 1969-71

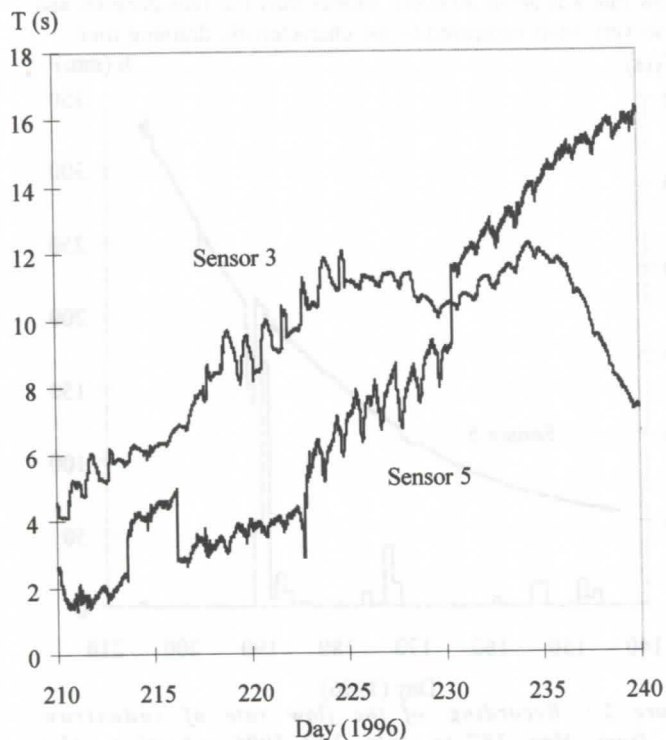

Figure 3 : Periodic variations of the flow rate of the two sodastraws, from July 28th to August 27th 1996. To allow the two recordings to be put on the same figure, an ordinate translation has been applied as following : $T_3 = T + 26$ s and $T_5 = T + 46$ s.

observations since in this latter case the main forcing was definitely semidiurnal. The low accuracy of the period determination is mainly due to the relatively bad signal/noise ratio of the periodic signals and to the limited duration of the period where the oscillations can be observed. According to the data of stalactites 3 and 5, these oscillations were indeed recorded only during about one month, mainly in August (figure 3), the same month where semidiurnal oscillations were observed in 1970. During the same time, stalactite 4 showed up clear discontinuity features with a period of about 24 hours.

Atmospheric and earth tide forcings differ in their frequency spectrum (TOMASCHEK, 1957 ; SIEBERT, 1961 ; MELCHIOR, 1978). Earth tides occur at the principal lunar and solar frequencies : O_1 (25.82 h, relative coefficient $R = 0.377$), K_1 (23.93 h, $R = 0.531$), M_2 (12.42 h, $R = 0.908$), S_2 (12.00 h, $R = 0.423$) whereas the atmospheric pressure tides occur at the solar frequencies K_1 and S_2 since they are mainly thermally driven. Comparison with our results suggests that the forcing observed in the Coufin cave is primarily of atmospheric origin which is consistent with the fact that the periodic oscillations seem to be observed only during the hot summer months. These observations are to be compared to the periodic pressure fluctuations inducing « cave breathing » which have been known for a long time. They were theoretically interpreted by WIGLEY (1967) who showed that the observation of unexpected large wind velocities induced by periodic pressure variations could be used in conjunction with the theory to gain information on the inaccessible volume of a cave, and/or to

estimate the combined « matrix and fracture » permeability of limestones. Nevertheless, earth tide forcing deserves more investigations since it is clearly displayed in the response of well-aquifer systems through the observations of the water level in wells (BREDEHOEFT, 1967 ; RITZI *et al.*, 1991 ; and references therein). Moreover there is at least one observation of a significant semidiurnal movement along a bedrock joint in a cave, with an amplitude of about $0.4 \mu\text{m}$ (DAVIS & MOORE, 1965).

5. Conclusions and perspectives

The preliminary results presented in this study demonstrate that the flow regimes of stalactites chosen at random in a same cave present some common behaviours like periodic oscillations and fast response to a swelling. That makes them powerful tools to study the hydraulic properties of the karstic microfissure network and ultimately to quantify the water flow and the transport of dissolved substances like trace elements, humic/fulvic acids and pollutants. In particular, these results establish that the response of the fissure network to a sudden and important water excess can be very fast, with an impulse response less than 10 hours. Of course this time is not the transfer time of water and more measurements are needed to understand how such short delays could be related to a flushing effect similar to what is observed on a macroscopic scale in underground rivers.

Although the comparison between the old results of the Grotte du Sourcier and the Coufin cave ones also suggests the existence of general behaviours, at least in the geographical area studied here, it shows important differences in the order of magnitude of the phenomena, which have to be understood and correlated with geological and geomorphological parameters. There is indeed important differences between these two caves : the Coufin cave develops at the basis of a massive limestone whereas the Grotte du Sourcier is a sub-cutaneous cave developing in a consolidated slope scree.

Although the high temporal resolution attainable with our data acquisition system has not yet been fully exploited, it is clear that it will be useful in the detailed study of swellings as well as periodic forcings. It will allow us to correlate dripping rates with environmental parameters such as temperature, atmospheric pressure, rains, insolation, river discharge, physico-chemical properties of water ...

High temporal resolution is also needed for the study of the flow rate discontinuities which seem to be a characteristic of the percolation regimes of all the stalactites studied in this work. Promising preliminary results are currently obtained in the analysis of these features by the deterministic chaos techniques.

If atmospheric forcing is confirmed, it should be also of interest to extend the WIGLEY's theory to transient pressure variations in order to try to interpret the strong 1970 perturbations induced by dry thunderstorms. Such perturbations have not yet been observed in the Coufin cave recordings but it must be recalled that the periodic oscillations recorded so far in this cave are much smaller than those observed in the « Grotte du Sourcier » cave.

Acknowledgements : The Centre d'Etudes et de Recherches Lasers et Applications (CERLA) is supported by the Ministère chargé de la Recherche, the Région Nord/Pas de Calais and the Fonds Européens de Développement Economique des Régions. We wish to gratefully acknowledge Gilbert Mantovani for

allowing us to install our equipment in the Coufin cave, and many thanks are also due to all the guides of this cave for their constant availability. We also thank Michel Gameau who built the electronic devices and Gilles Marcou who carried out, as a summer student, many laboratory experiments on the drop volume.

References

- BAKER, A., SMART, P. L. & R. L. EDWARDS. 1995. Paleoclimate implications of mass spectrometric dating of a british flowstone. *Geology* 23 : 309-312.
- BASKARAN, M. & R.V. KRISHNAMURTHY. 1993. Speleothems as proxy for the carbon isotope composition of atmospheric CO₂. *Geophys. Res. Lett.* 20 : 2905-2908.
- BREDEHOEFT, J. D. 1967. Response of well-aquifer systems to Earth tides. *J. Geophys. Res.* 72 : 3075-3087.
- DAVIS, S. N. & G. W. MOORE. 1965. Semidiurnal movement along a bedrock joint in Wool Hollow cave, California *Bull. Nat. Speleological Soc.* 27 : 133-142.
- DELANNOY, J. J. 1986. Contribution à l'étude des circulations aquifères dans le géosystème Coulmes-Choranche. Présentation du site expérimental de la Grotte de Coufin. *Rev. Géogr. Alpine*, T. LXXIV, 83-92.
- DELANNOY, J. J., GUERDON, J. L. & Y. QUINIF. 1988. Les remplissages spéléologiques : un apport à la connaissance de la karstogénèse du massif des Coulmes (Vercors, Alpes). *Ann. Soc. Géol. Belg.* 111 : 21-38.
- DELANNOY, J. J. 1991. : Vercors, Histoire du relief. Carte géomorphologique commentée. Editions du Parc naturel régional du Vercors .
- DELANNOY, J. J. 1997. Thèse de Doctorat d'Etat, Grenoble.
- DESTOMBES, J. L. 1971. Unpublished results.
- DREYER, K. & F. R. HICKEY. 1991. The route to chaos in a dripping water faucet. *Am. J. Phys.* 59 : 619-627.
- EGGERS, J. 1995. Theory of drop formation. *Phys. Fluids* 7 : 941-953.
- FORDHAM, S. 1948. On the calculation of surface tension from measurements of pendant drops. *Proc. R. Soc. London A* 190 : 1-16.
- GARANDET, J.P., VINET, B. & P. GROS. 1994. Considerations on the pendant drop method : A new look at Tate's law and Harkins' correction factor. *J. Colloid Interface. Sci.* 165 : 351-354.
- GASCOYNE, M. 1992. Paleoclimate determination from cave calcite deposits. *Quatern. Sci. Rev.* 11 : 609-632.
- GENTY, D. & Y. QUINIF. 1996. Annually laminated sequences in the internal structure of some belgian stalagmites - Importance for paleoclimatology. *J. Sediment. Res.* 66 : 275-288.
- GENTY, D., DEFLANDRE, G., QUINIF, Y. & S. VERHEYDEN. 1996. Les lamines de croissance des spéléothèmes : origine et intérêt paléoclimatique. *Ann. Soc. Géol. Belg.* in press.
- GOEDE, A. 1994. Continuous early last glacial palaeo-environmental record from a tasmanian speleothem based on stable isotope and minor element variations. *Quatern. Sci. Rev.* 13 : 283-291.
- GORDON, D., SMART, P. L., FORD, D. C., ANDREWS, J. N., ATKINSON, T. C., ROWE, P. J. & N. S. J. CHRISTOPHER. 1989. Dating of late pleistocene interglacial and interstadial periods in the United Kingdom from speleothem growth frequency. *Quatern. Res.* 31 : 14-26.
- HARMON, R. S., THOMPSON, P., SCHWARCZ, H. P. & D. C. FORD. 1978. Late pleistocene paleoclimates of North America from stable isotope studies of speleothems. *Quatern. Res.* 9 : 54-70.
- HENNIG, G. J., GRÜN, R. & K. BRUNNACKER. 1983. Speleothems, travertines and paleoclimates. *Quatern. Res.* 20 : 1-29.
- HARKINS, W. D. & F. E. BROWN. 1919. The determination of surface tension and the weight of falling drops : the surface tension of water and benzene by the capillary height method. *J. Amer. Chem. Soc.* 41 : 499-524.
- KASHIWAYA, K., ATKINSON, T. C. & P. L. SMART. 1991. Periodic variations in late pleistocene speleothem abundance in Britain. *Quatern. Res.* 35 : 190-196.
- LAURITZEN, S. E., LØVELY, R., MOE, D. & E. ØSTBYE. 1990. Paleoclimate deduced from a multidisciplinary study of a half-million-year-old-stalagmite from Rana, Northern Norway. *Quatern. Res.* 34 : 306-316.
- LAURITZEN, S. E. 1996a : Climate Change : the Karst Record. Extended abstracts of the Bergen Conference, August 1-4th, 1996, University of Bergen, Norway.
- LAURITZEN, S. E. 1996b. Private communication.
- LISMONDE, B. 1996. Private communication.
- MAIRE, R. & Y. QUINIF. 1988. Chronostratigraphie et évolution sédimentaire en milieu alpin dans la galerie Aranzadi (Gouffre de la Pierre Saint Martin, Pyrénées, France). *Ann. Soc. Géol. Belg.* 111 : 61-77.
- MELCHIOR, P. J. 1978. The tides of the planet Earth. Pergamon, Elmsford, N.Y. 1978.
- PEREGRINE, D. H., SHOKER, G. & A. SYMON. 1990. The bifurcation of liquid bridges. *J. Fluid Mech.* 212 : 25-39.
- RITZI, R. W. JR., SOROOSHIAN, S. & P. A. HSIEH. 1991. The estimation of fluid flow properties from the response of water levels in wells to the combined atmospheric and Earth tide forces. *Water Resour. Res.* 27 : 883-893.
- RAYLEIGH, LORD. 1899. Investigations in capillarity. *Phil. Mag.* 48 : 321-337.
- ROJSTACZER, S. 1988. Determination of fluid flow properties from the response of water levels in wells to atmospheric loading. *Water Resour. Res.* 24 : 1927-1938.
- SCHULKES R. M. S. M. 1994. The evolution and bifurcation of a pendant drop. *J. Fluid Mech.* 278 : 83-100.
- SHAW, R. S. 1984. The dripping faucet as a model chaotic system ; Aerial, Santa Cruz, CA, USA.
- SHI, X. D., BRENNER, M. P. & S. R. NAGEL. 1994. A cascade of structure in a drop falling from a faucet. *Science* 265 : 219-222.
- SIEBERT, M. 1961. Atmospheric tides. *Advances in Geophysics*. H. E. Landsberg & J. Van Mieghem Ed. 7 : 105-187. Acad. Press, 1961.
- SZABO, B. J., KOLESAR, P. T., RIGGS, A. C., WINOGRAD, I. J. & K. R. LUDWIG. 1994. Paleoclimatic inferences from a 120000-yr calcite record of water-table in Browns room of Devil's Hole, Nevada. *Quatern. Res.* 41 : 59-69.
- TATE, T. 1864. On the magnitude of a drop of liquid formed under different circumstances. *Phil. Mag.* 27 : 176-180.
- TOMASCHEK, R. 1957. Tides of the solid Earth. *Encyclopedia of Physics, Geophysics II*. S. Flügge Ed. Vol. XLVIII : 773-845. Springer Verlag, 1957.
- WIGLEY, T. M. L. 1967. Non-steady flow through a porous medium and cave breathing. *J. Geophys. Res.* 72 : 3199-3205.
- WU, X., TECKLE, E. & Z. A. SCHELLY. 1989. Dripping faucet apparatus with temperature and high resolution timing and flow rate controls. *Rev. Sci. Instrum.* 60 : 3779-3782.
- ZHANG, X. & O. A. BASARAN. 1995. An experimental study of dynamics of drop formation. *Phys. Fluids* 7 : 1184-1203.

Early evolution of karst aquifers in limestone : Models on two-dimensional percolation clusters

by Wolfgang Dreybrodt & Jörg Siemers

Institute of Experimental Physics, University of Bremen, 28334 Bremen Germany

Abstract

Two-dimensional nets of initial fractures are constructed on a square-lattice by occupying the lines between nearest neighbour sites by a water leading fissure of width a_0 and length l with an occupation probability p . For $p > 0.5$ percolating nets occur which lead water. To simulate cave genesis we calculate the water flow rates driven by the hydraulic head h through all fissures. By employing nonlinear dissolution rates of the type $F = k_n(1 - c/c_{eq})^n$ the widening of the fractures is obtained. At the onset of karstification flow is evenly distributed on all fractures. As the system develops solutional widening creates preferred pathways, which attract more and more flow, until at breakthrough both widening and flow increase dramatically. We discuss the evolution of karst aquifers for natural conditions and also upon human impact at dam sites where steep hydraulic gradients may generate water leading conduits below the dam in times comparable to the lifetime of the structure.

1. Introduction

To understand processes of the early state of karst genesis, one-dimensional models have been developed which couple widening of primary fractures in limestone by dissolution, and flow rates of the water driven from the input to the output (DREYBRODT, 1990, 1996; PALMER, 1991; GROVES & HOWARD, 1994). These models show that the width of the fracture at its exit increases slowly by dissolution until it has been doubled. From then on a positive feedback loop is enhanced, and within an extremely short time, width and flow rates increase dramatically.

The time, when this happens is termed as breakthrough time and terminates early evolution. This time can be estimated to be $T_B \simeq a_0/F(1,0)$ [years], where a_0 [cm] is the initial width of the fracture and $F(1,0)$ is the limestone dissolution rate in $\text{cm} \cdot \text{year}^{-1}$ at the end of the developing channel at the onset of its evolution. From this an expression has been derived which quantifies breakthrough time as a function of the parameters, which determine karstification (DREYBRODT, 1996). These are the initial width a_0 , the breadth b_0 , the length l of the fracture, and the hydraulic head h between the input and the output, which is assumed as constant until breakthrough occurs. Furthermore the kinetics of dissolution plays a role of utmost importance. It is quantified by the equilibrium concentration c_{eq} with respect to calcite, which can be attained by the aggressive solution, and the constants determining the dissolution rates as a function of the calcium concentration c in the solution. For narrow initial fractures with widths between $5 \cdot 10^{-3}$ cm up to $1 \cdot 10^{-1}$ cm these rates are given by a linear relation $F_1(c) = k_1(1 - c/c_{eq})$ (DREYBRODT *et al.*, 1996). Close to equilibrium at $c \simeq 0.8 c_{eq}$ the rates, however, switch to a higher order law $F_n = k_n(1 - c/c_{eq})^n$, where $n=11$ for karstifying limestone (SVENSSON & DREYBRODT, 1992; EISENLOHR *et al.*, 1997). Without this switch to a higher order, karstification for natural systems, i.e. evolution of conduit aquifers, would not be possible at all.

The work described so far enables one to a first understanding on the early evolution of karst in its dimensions on space and time. More realistic models, however, are required. In this work we report on two-dimensional models, which incorporate the statistical distribution of primary fractures. We will give some examples for natural karst systems. We will also model karst evolution for man-made conditions, such as dam sites, where extremely steep hydraulic gradients favor the development of karst channels in short times.

2. Model structure

To model the random distribution of initial fractures in limestone penetrable by water, a percolation network is constructed by the following rules: Fig. 1 depicts an array of squares, shown by their corner points. Each side

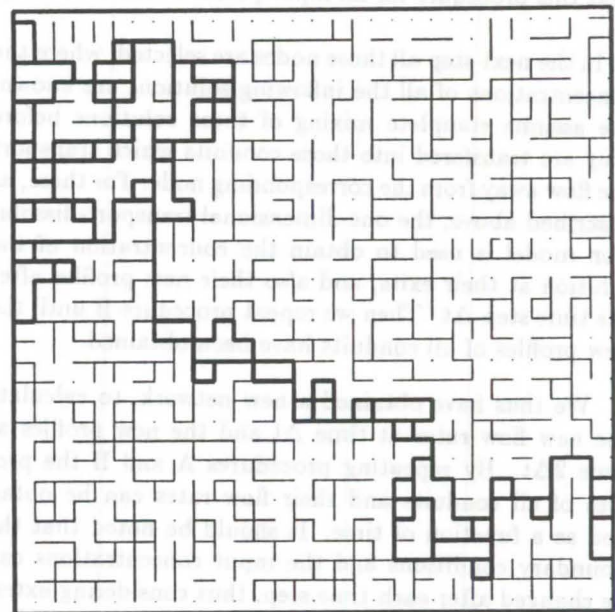

Figure 1: Fracture network with an occupation probability $p=0.5$. The fat lines represent fractures, which transport water flow.

of a square represents a location, which could possibly

host a fracture. These locations are randomly occupied with an occupation probability $p > 0.5$. The full lines in Fig. 1 represent such fractures and form a percolating network. Depending on the boundary conditions, some of those fractures transmit water from the input to the output (fat lines), others do not (thin lines). In Fig. 1 the lower and upper side of the network are assumed as impervious. The left hand side is subject to a hydraulic head h , whereas the right hand side is at low hydraulic head $h=0$. Only the percolating pathways (fat lines) carry water. Such percolating pathways can be constructed with various occupation probabilities p , to model the degree of fracturing in the rock. For values $p < 0.5$ no percolating pathways will occur. With increasing p the density of the network increases. Fig. 1 represents a net with $p=0.5$. Later on in this work we will use networks with $p=0.7$. Compare Fig. 2.

To calculate the flow rates in each fracture a yet unknown hydraulic head h_i is assigned to each node, where two or more fractures are connected. Assuming laminar flow, which is verified by calculating the REYNOLD's number, a set of linear flow equations is obtained, which depend on the geometric profile of each fracture. From these the heads h_i are found. Then we calculate the dissolutional widening for all tubes in the following way:

A. First we select an input at the boundary of the network. We specify the concentration c_{in} of the solution, which flows in to the input fracture. Then we apply the one-dimensional transport-dissolution model (DREYBRODT, 1996) to calculate the concentration profile along this channel, including the concentration of the solution leaving it. Furthermore we calculate the new profile of the channel after a time step Δt . We repeat this procedure for all input points at the boundary.

B. In the next step all those nodes are selected, where the concentrations of all the inflowing solutions are known. We assume complete mixing of these solutions before they are transferred into those conduits which transport the flow away from the corresponding node. For these, as described above, the one-dimensional transport-dissolution model is used to obtain the concentration of the solution at their exits, and also their new profiles after the time step Δt . Then we repeat procedure B until the new profiles of all conduits have been obtained.

We thus have obtained a new network, to calculate the new flow rates at time Δt and the new profiles at time $2\Delta t$. By repeating procedures A and B the profiles of all conduits and their flow rates can be obtained as a function of time. It should be noted that the boundary conditions and the input concentrations can be changed after each time step, thus considering external changes by climate or geological changes (up-lifting, down-cutting of base level).

3. Results

Natural conditions

Natural karst systems are characterized by low hydraulic gradients h/l , and large values of l . Fig. 2 depicts such a system. The length of the square is 3 km. We assume all sides of the square to be impervious, with the following exceptions. At the left hand side we have defined three input points marked by arrows at a hydraulic head of $h=150$ m. There is one output point at the upper corner of the right hand side, located at base level, $h=0$. The following parameters have been used in this model, $p=0.7$, $a_0=10^{-2}$ cm, $b_0=100$ cm, $c_{in}=0$, $c_{eq}=2$ mmole \cdot l $^{-1}$, $c_s=1.5$ mmole \cdot l $^{-1}$, $k_1=4 \cdot 10^{-11}$ mole \cdot cm $^{-2} \cdot$ s $^{-1}$, $k_{11}=4.2 \cdot 10^{-5}$ mole \cdot cm $^{-2} \cdot$ s $^{-1}$, and $n=11$. Fig. 2a shows the fracture widths which have evolved after 280285 years. The thin lines (—) depict fractures with widths < 0.1 cm. Correspondingly (—) depicts fractures between 0.1 and 1 cm, and (—) fractures with widths between 1 cm up to 10 cm. Finally the fattest lines (—) denote fractures larger than 10 cm.

From Fig. 2a one visualises that a karst channel has developed from the upper input towards the output, penetrating half their distance. The other two inputs located a higher effective distance to the output, less successfully, have created only short channels. Only 1300 years later, however, the upper channel has reached the output (Fig. 2b), causing a dramatic increase in the flow rate, as is depicted by Fig. 3. Since these high flow rates cannot be delivered from the storage of the system, the boundary conditions at the upper input are changed to a constant inflow of 500 cm $^3 \cdot$ s $^{-1}$. At such high flow the concentration at the output, close to saturation prior to breakthrough, drops to low values (see Fig. 3) and the upper channel widens with a rate of several cm in hundred years. Fig. 2c shows the system after further 10500 years. Due to the low hydraulic head established in the upper channel by restricted input, the second input point has directed its channel evolution upward and thus created a second breakthrough event as shown by Fig. 3. Therefore also at this input point the inflow becomes limited (500 cm $^3 \cdot$ s $^{-1}$), whereas the lowest input remains at constant head. Fig. 2d shows the situation only 800 years later at 292023 years. The lowest channel has succeeded to reach the upper network. From this moment on there is almost equal widening everywhere in the conduits, and the structure of the conduit system will remain unchanged if the boundary conditions remain unchanged. It should be noted that the evolution of the first channel in Fig. 2a takes 280000 years, whereas the further development needs only 12500 years. Fig. 3 shows the evolution of flow rates Q leaving the exit. Furthermore the width a of the exit conduit and also the concentration of the water at the exit are illustrated. From this one sees that the first breakthrough event takes the system into the state of adolescence going to maturity a short time later. Prior to the first breakthrough the width and the flow rates increase slowly. The concentration at the exit is high and therefore dissolution rates are low. After breakthrough the concentration c drops and dissolution rates become high.

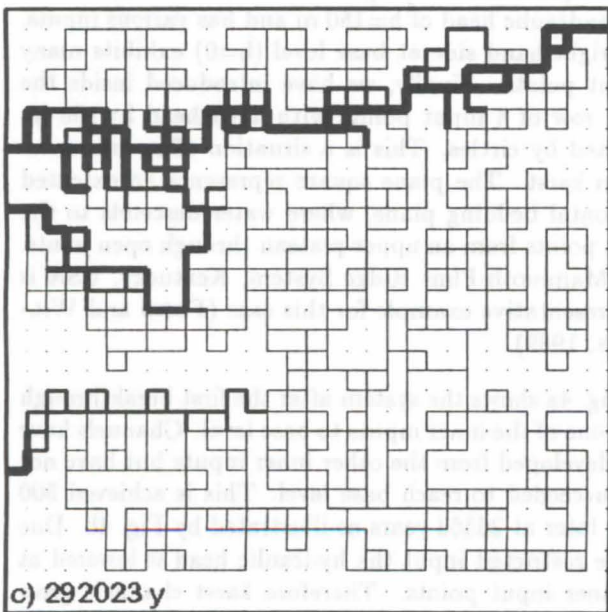
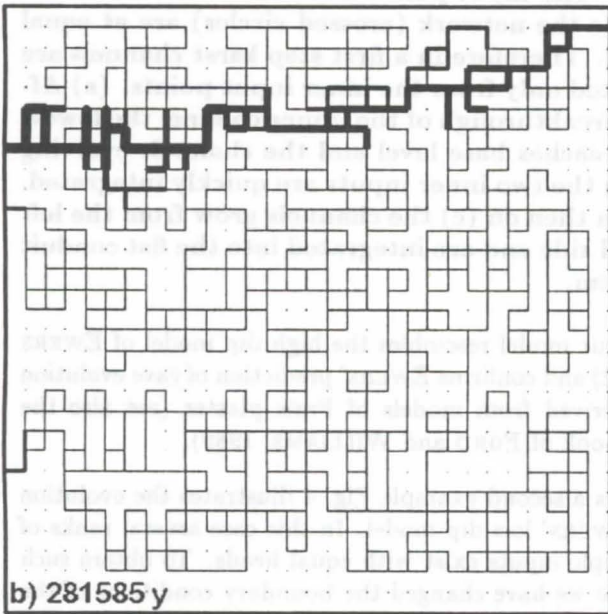
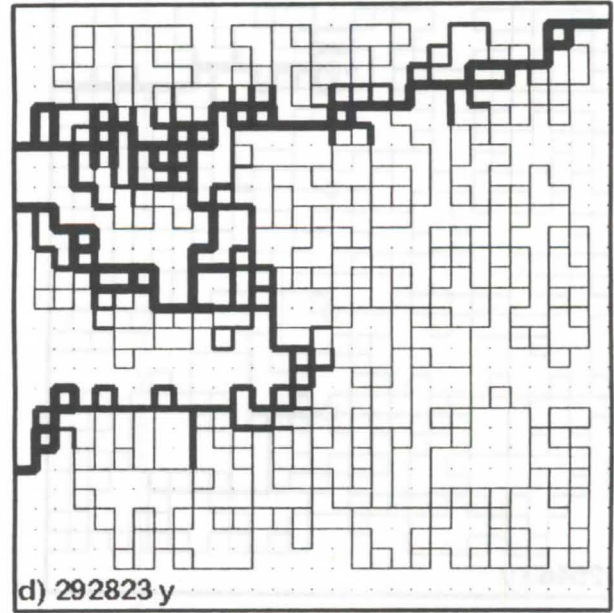
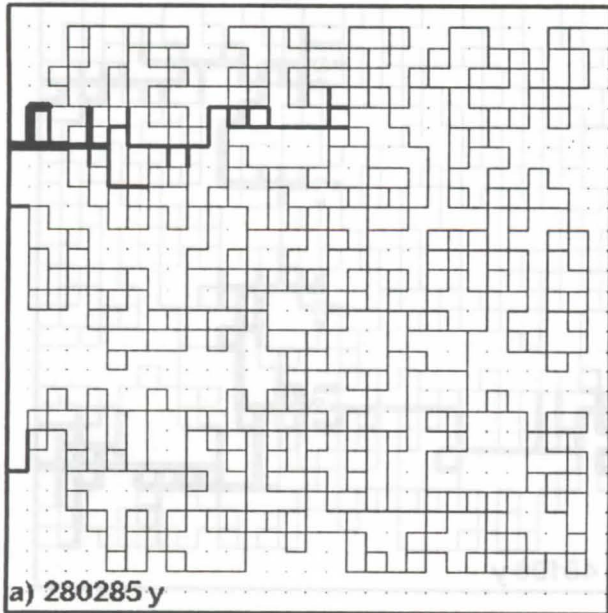

Figure 2: Evolution of a karst aquifer of $3 \times 3 \text{ km}^2$, with 3 inputs (left hand side) at $h=150 \text{ m}$ and one output at base level ($h=0$). (high dip model). (a) First karst channels develop until (b) at a first breakthrough event the upper channel has reached base level. (c) The next channel is directed towards the upper channel and a next breakthrough event occurs. (d) Finally the lowest channel is integrated into the network.

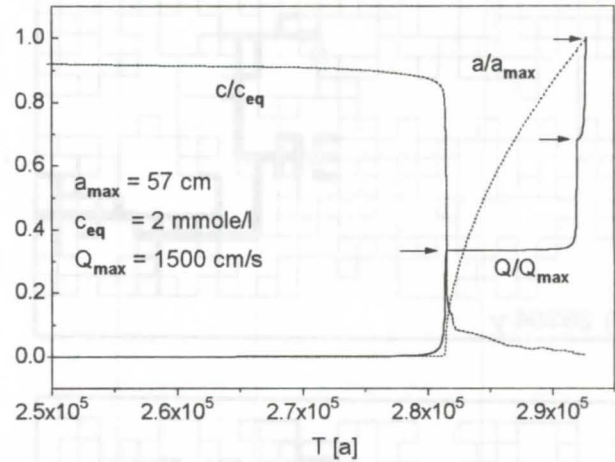

Figure 3: Time dependence of flow rate $Q(t)$, fracture width $a(t)$ at the exit, and concentration $c(t)$ of the water at the exit. All values are normalized to the maximal values at the end of the run. The arrows designate the breakthrough events in Figs. 2b,c, and d.

Therefore $a(t)$ increases quickly. The nonlinear behaviour of $a(t)$ results from the fact, that at large $a(t)$ the dissolution rates are controlled by diffusional transport.

One should note at this point that the breakthrough time for each event depends critically on the initial fracture widths by $T_B \propto a_0^{-2.3}$. (DREYBRODT, 1996, SIEMERS and DREYBRODT, 1997). Thus upon a change of a_0 from 0.01 cm to 0.02 cm breakthrough times would be reduced from about 290000 years to about 60000 years.

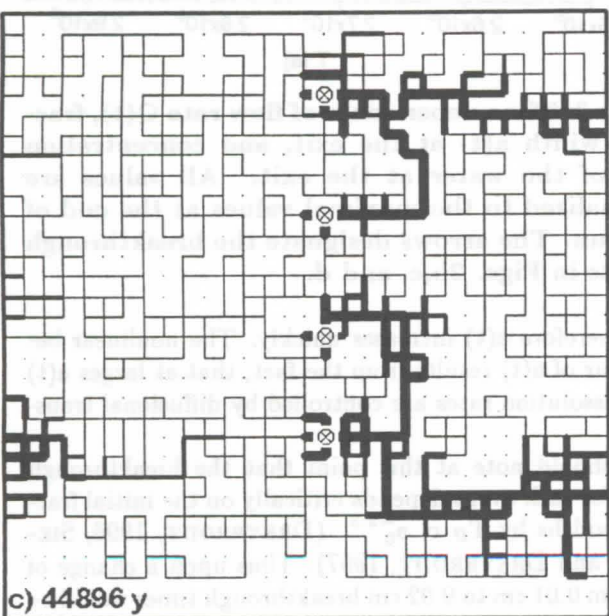
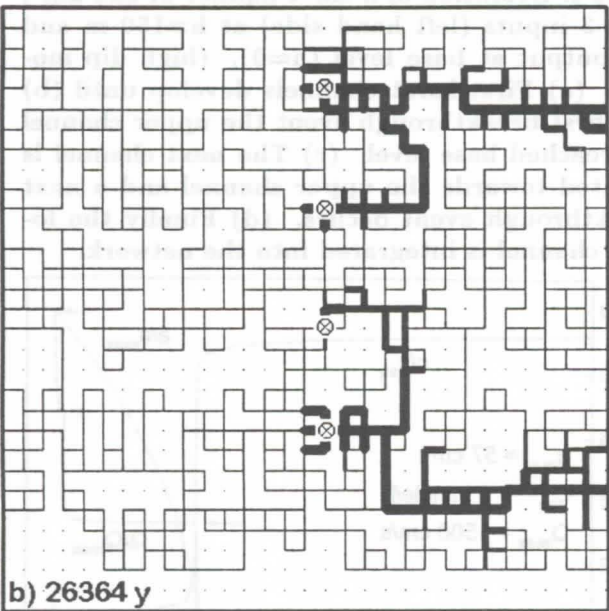
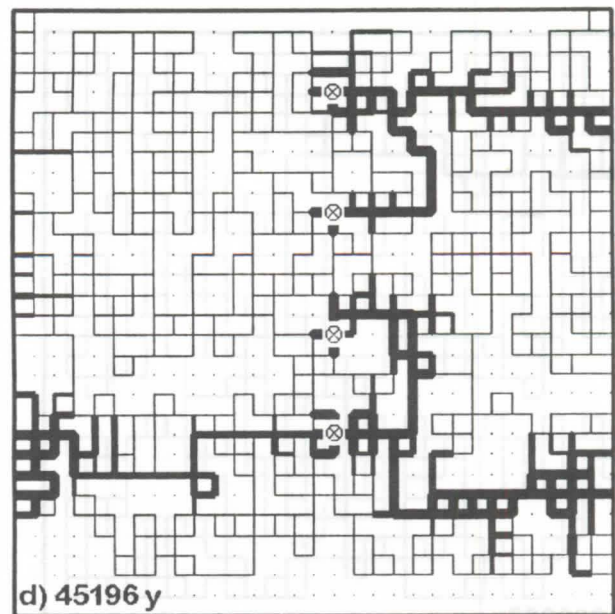
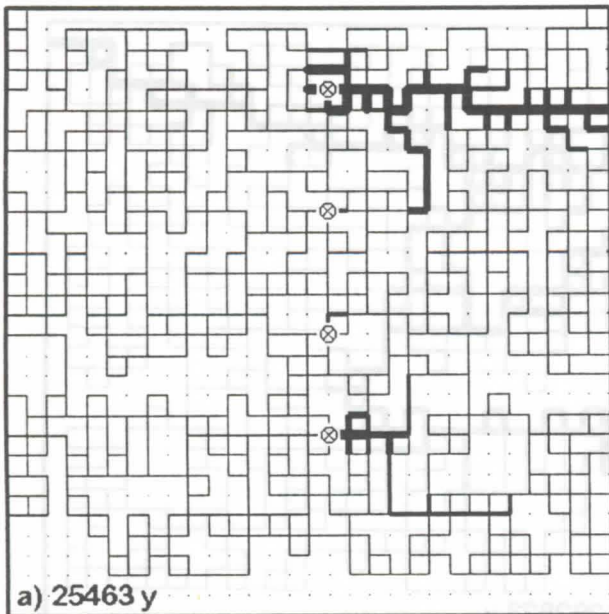

Figure 4: Evolution of a karst aquifer (low dip model). The input points at the left hand side and inside the network (crossed circles) are at equal head. Therefore in a first step karst channels are created only from the inner input points. (a) After breakthrough of the upper channel the lowest (b) reaches base level and the channels evolving from the two inner inputs are quickly integrated. From then on (c) the channels grow from the left hand side and are integrated into the fist conduit system.

Our model resembles the high dip model of EWERS (1982) and confirms EWERS' prediction of cave evolution as derived from models of Paris plaster (see also the textbook of FORD and WILLIAMS, 1989).

As a second example Fig. 4 illustrates the evolution of EWERS' low dip model. In this case several ranks of multiple inputs exist with equal heads. To obtain such a case we have changed the boundary conditions of the network depicted in Fig. 2. The upper and lower sides of the square are still impervious. The left hand side is at a hydraulic head of $h=150$ m and has various inputs. The right hand side at base level ($h=0$) exhibits many output points. Finally, we have introduced inside the net a row of 4 input points with fixed head $h=150$ m, depicted by circles. This is a situation often encountered in karst. The plane square represents an extended horizontal bedding plane, where water descends to the input points from an upper plateau through open joints. The Mammoth-Flint Ridge System, Kentucky, USA is a representative example for this case (FORD and WILLIAMS, 1989).

Fig. 4a shows the system after the first breakthrough from one of the inner inputs to base level. Channels have also developed from the other inner inputs but have not yet succeeded to reach base level. This is achieved 500 years later at 26363 years as illustrated by Fig. 4b. Due to the restricted input the hydraulic head is lowered at all inner input points. Therefore karst channels grow

downhead from the inputs at the left hand side. They reach, as seen in Fig. 4c those conduits already created, in a further 19000 years. If there are further arrays of input points, this scenario is repeated. Thus dissolution creates channels growing downhead. Integration of the cave system, however, proceeds uphead. The reduction of breakthrough times in comparison to the case presented by Fig. 2 results from the fact that breakthrough times are related to the hydraulic head and the effective length between the input and the output by $T_B \propto (l^2/h)^{1.1}$. (DREYBRODT, 1996, SIEMERS & DREYBRODT, 1997).

Fig. 5 as a further example, shows a vertical cave in its final state after 5700 years. The boundary conditions are: The left hand side and the lower side of the aquifer are impermeable. The upper side represents a plateau 3 km wide at an elevation of 300 m with various input points. The right hand side illustrates a vertical cliff with various output points at different heights, the lowest at base level, e.g. a valley. We have used $a_0=0.01$ cm, everything else is unchanged. Note that the vertical dimension now is only 0.3 km. The system evolves as follows: First the input nearest to the edge creates breakthrough at the upper most outlet after 3496 years. Its input is then restricted. Other inputs, still at high hydraulic head, develop channels integrating to the first channel system. Furthermore vertical shafts are created simultaneously.

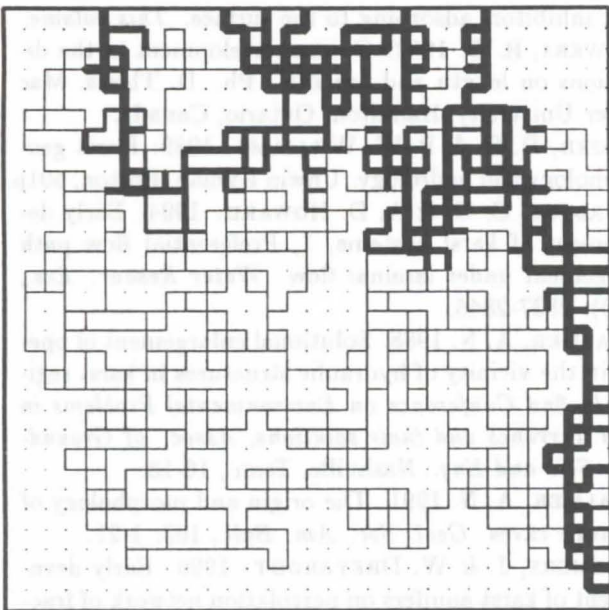

Figure 5: Final state of a vertical cave system.

In conclusion the examples presented, show that the structure of the conduits in a karst aquifer are determined by the initial setting of the fracture system and by the boundary conditions. After a long time of initiation until the first breakthrough event, complex patterns arise in comparably short times. Furthermore realistic evolution times of karst systems are obtained by use of realistic geometrical parameters a_0 , b_0 , l , and h and chemical dissolution kinetics, as obtained from the laboratory.

Man-made conditions

Close to hydraulic structures, such as dam sites, unnaturally steep hydraulic gradients are created, and a sufficiently large supply of water driven by these high gradients through fractures beneath the foundation and across the abutment rock is always provided. Therefore the question arises, whether within the lifetime of the dam, dissolutional widening might create channels sufficiently wide to cause serious loss of water.

We therefore have applied our model to a situation illustrated by Fig. 6.

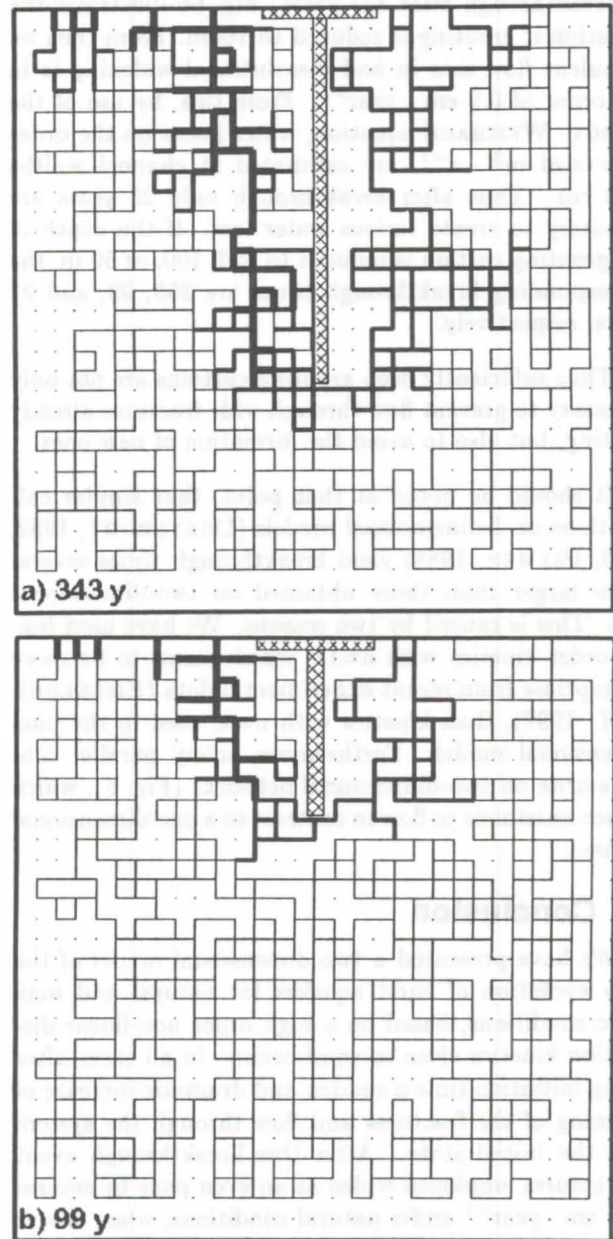

Figure 6: Evolution of conduits below a dam. (a) With a grouting curtain 200m deep, breakthrough occurs after 343 years. (b) Reducing the depth of grouting to 100m results in breakthrough after 99 years. In both cases the channel widths at the exit have increased by a factor of ten to 0.16 cm.

We have constructed a percolation net with $p=0.7$ and imposed the following boundary conditions. A grouting curtain below the dam creates an impervious layer 10 m wide and 200 m deep, and thus blocks flow. This is depicted by the shaded area in Fig. 6a. The basal width of the dam is 50 m and impervious (shaded area). To the left of the dam water is impounded at a height of 200 m and several input points are available. To the right hand side $h=0$. The remaining sides of the 300 m wide square are assumed as impervious for simplicity. The width of the initial fractures is $a_0=0.015$ cm.

Fig. 6a represents the channels, which have evolved at breakthrough after 343 years. Fig. 6b illustrates the situation if grouting is reduced to 100m. From then on turbulent flow sets in and dissolutional widening is in the order of $0.2 \text{ cm} \cdot \text{year}^{-1}$. From this, by use of the DARCY- WEISBACH equation, water losses on the order of several $\text{m}^3 \cdot \text{s}^{-1}$, are estimated at channel widths of 5 cm. Thus after breakthrough only 25 years are necessary to create serious water loss. If the depth of the grouting curtain is reduced to 150, 100, or 50 m, the corresponding breakthrough times are 255, 99, and 27 years, respectively.

Thus sufficiently deep grouting curtains are not only necessary to prevent flow through wide fractures already existing, but also to avoid the formation of new ones.

It should be noted at that point, that similar calculations on 1-dimensional models (DREYBRODT, 1992, 1996; PALMER, 1988) yield breakthrough times several times larger than those obtained on two-dimensional nets. This is caused by two reasons. We have used higher order kinetics with $n=11$, which seems to be more appropriate from recent experimental data (EISENLOHR *et al.*, 1997), than kinetics with $n=4$, used in the one-dimensional model. Furthermore, many parallel conduits arise on two-dimensional networks (Fig. 6), which reduce resistance to flow in contrast to a one-dimensional channel.

4. Conclusion

We have presented a two-dimensional model of the early evolution of karst aquifers for natural and man made conditions, based on a high order non-linear dissolution kinetics close to equilibrium. In all cases after a long initiation time a sudden and dramatic increase of widening of the fractures and flow through the system ends the initial state. After this breakthrough event all fractures employed widen at an even pace by several $10^{-2} \text{ cm} \cdot \text{year}^{-1}$ under natural conditions, when flow is laminar. If flow becomes turbulent the annual widening increases by enhancement of diffusional mass transport (DREYBRODT and BUHMANN, 1991) up to about 10^{-1} cm. The latter occurs when after breakthrough a sufficient amount of water is provided, as is the case at dam sites. For natural conditions, depending on the boundary conditions, complex conduit patterns arise, which give a realistic simulation of cave geomorphology and its dimensions on space and time. Application of the mo-

del to man-made conditions, such as dam sites in karst, provides strong suspicion, that new karst channels may develop below the dam, which cause serious water losses within its lifetime.

References

- DREYBRODT, W. 1990. The role of dissolution kinetics in the development of karstification in limestone: A model simulation of karst evolution. *J. Geol.*, 98: 639-655.
- DREYBRODT, W. 1992. Dynamics of karstification: A model applied to hydraulic structures in karst terranes. *Appl. Hydrogeo.*, 1: 20-32.
- DREYBRODT, W. 1996. Principles of early development of karst conduits under natural and man-made conditions revealed by mathematical analysis of numerical models. *Water Resour. Res.*, 32(9): 2923-2935.
- DREYBRODT, W. & D. BUHMANN. 1991. A mass transfer model for dissolution and precipitation of calcite from solutions in turbulent motion. *Chem. Geol.*, 90: 107-122.
- DREYBRODT, W.; LAUCKNER J.; LIU Z.; SVENSSON U. & B. BUHMANN 1996. The kinetics of reaction $\text{CO}_2 + \text{H}_2\text{O} \rightarrow \text{H}^+ + \text{HCO}_3^-$ as one of the rate limiting steps for the dissolution of calcite in the system $\text{H}_2\text{O}-\text{CO}_2-\text{CaCO}_3$. *Geochim. Cosmochim. Acta*, 60(18): 3375-3381.
- EISENLOHR, L.; MADRY B. & W. DREYBRODT 1997. Changes in the dissolution kinetics of limestone by intrinsic inhibitors adsorbing to the surface. *This volume*.
- EWERS, R. O. 1982. Cavern development in the dimensions on length and breadth. Ph. D. Thesis, Mac Master University, Hamilton, Ontario, Canada.
- FORD, D. C. & P. W. WILLIAMS. 1989: Karst geomorphology and hydrology. Unwin Hyman, Boston, 601p.
- GROVES, C. G. & A. D. HOWARD. 1994. Early development of karst systems, 1, Preferential flow path enlargement under laminar flow. *Water Resour. Res.*, 30(10): 2837-2846.
- PALMER, A. N. 1988. Solutional enlargement of opening in the vicinity of hydraulic structures in karst regions. *In 2nd Conference on Environmental Problems in Karst Terranes and their solutions, Assoc. of Groundwater Sci. and Eng.*, Nashville, Tenn., 16-18.
- PALMER, A. N. 1991. The origin and morphology of limestone caves. *Geol. Soc. Am. Bull.*, 103: 1-21.
- SIEMERS, J. & W. DREYBRODT. 1996. Early development of karst aquifers on percolation network of fractures in limestone. *Submitted to Water Resour. Res.*
- SVENSSON, U. & W. DREYBRODT. 1992. Dissolution kinetics of natural calcite minerals in CO_2 -water systems approaching calcite equilibrium. *Chem. Geol.*, 100: 129-145.

Acknowledgements:

We thank the Deutsche Forschungsgemeinschaft for financial support.

Changes in the dissolution kinetics of limestone by intrinsic inhibitors adsorbing to the surface

by Laurent Eisenlohr, Britta Madry & Wolfgang Dreybrodt
Institute of Experimental Physics, University of Bremen, 28334 Bremen Germany

Abstract

We have measured the dissolution rates of natural carbonate-CaCO₃ minerals by employing a free-drift experiment, where sized particles were suspended by turbulent stirring in a H₂O-CO₂ solution. The experimental system was closed with respect to CO₂ as is the case in the evolution of karst aquifers. At low calcium concentrations c we find a rate law $F_1 = k_1(1 - c/c_{eq})^{n_1}$, which switches to a higher order law $F_2 = k_2(1 - c/c_{eq})^{n_2}$ above a concentration c_s . The values of the constants k_1 , k_2 , of n_1 , n_2 and of c_s , depend systematically on the ratio V/A , where V is the volume of the solution and A the surface area of the dissolving mineral. This result can be explained by assuming that inhibitors are present in the bulk of the mineral, which upon dissolution accumulate on its surface. Thus inhibition increases with the thickness of the layer removed from the limestone, which is proportional to the V/A -ratio. These results are discussed with respect to previous experiments in the literature and with respect to the genesis of limestone aquifers.

1. Introduction

In order to model the time-space relationship of karst environments, exact knowledge on the dissolution kinetics of limestone is rigorously required (DREYBRODT, 1988, 1990, 1996; PALMER, 1991; GROVES & HOWARD, 1994). Extensive experimental work has been published on the dissolution kinetics of calcite in the system CaCO₃-H₂O-CO₂ under open system conditions with respect to CO₂. PLUMMER & WIGLEY (1976) showed that dissolution rates observed on Iceland spar could be described by an empirical relation:

$$F_1 = k_1(1 - c/c_{eq})^{n_1}, \text{ for } c \leq c_s, \text{ and} \quad (1)$$

$$F_2 = k_2(1 - c/c_{eq})^{n_2}, \text{ for } c > c_s \quad (2)$$

k_1 , k_2 are rate constants, c is the concentration of Ca²⁺ in the solution, and c_{eq} the equilibrium concentration with respect to calcite. c_s is the concentration, where the rate law switches from order n_1 to order n_2 , $n_2 > n_1$. They observed $n_1 \simeq 2$, $c_s/c_{eq} \simeq 0.9$ and $n_2 \simeq 4$, but in some runs also values up to 8. Using the experimental data of PLUMMER *et al.* (1978) from dissolution rates on Iceland spar at various p_{CO_2} and temperatures, PALMER (1991) found a similar rate equation. SVENSSON & DREYBRODT (1992) have carried out measurements of dissolution on natural limestones, marbles, and calcareous deep-sea sediments which have confirmed the rate laws above on these materials. They found values of n_1 in the range from 1.2 up to 2.5. Beyond a value of c_s/c_{eq} in the range from 0.6 up to 0.9 the dissolution rates switched to higher order with $2.5 \leq n_2 \leq 4.9$. In contrast, dissolution rates obtained experimentally on synthetic calcite (NBS) exhibited a linear dissolution behaviour with $n_1 \simeq 1$ which is closely related to the theoretical dissolution rates predicted by the PWP-model (PLUMMER *et al.*, 1978). This fundamental difference between dissolution of natural material and synthetic calcite has been explained by the presence of inhibitors which are originally in the bulk of the mineral. During dissolution those trace elements as e.g. Cu²⁺, Pb²⁺ or

PO₄³⁻ are absorbed to the calcite surface and block dissolution processes.

So far all experimental rates reported have been obtained under conditions of a system open with respect to CO₂. The aim of this study is to investigate dissolution kinetics of limestone under closed system conditions with respect to CO₂, since these conditions determine initial processes in karst evolution.

2. Material and method

Limestone from the Swiss Jura Mountains was used in all the experiments. This material was ground, size fractioned, treated with diluted HCl (0.02 molar), cleaned in bidistilled water, in acetone and finally dried at 30°C. The size fractions selected for the dissolution experiments were 100-125 μm, 125-180 μm, 180-250 μm, 250-355 μm, 355-500 μm, and 500-710 μm. The surface area was estimated from the weight of the sized material and the mean dimension of the particles, assuming each particle as a rhombohedron. Dissolution experiments have also been performed on limestone disks from the same material. These disks were 7 mm thick slabs with a diameter of 5.8 cm. The limestone face exposed to dissolution was smoothed and polished using progressively 1200, 2400 and 4000 silicon carbide paper, then treated in HCl (0.02 molar), cleaned in bidistilled water and dried. The disks were mounted into the bottom of the reaction vessel. Fig. 1 shows the experimental set-up. The experiments were carried out as batch runs, using the free-drift technique. The solution was contained in a Teflon vessel (1) with a volume $V = 262 \text{ cm}^3$, thermostated at $10 \pm 0.1^\circ\text{C}$. No further space for air was available. Particles were kept in suspension by turbulent stirring the solution with a propeller at 350 rpm (3) and (5). The experiment was started by filling the Teflon vessel with bidistilled water in equilibrium with a CO₂-atmosphere of $5 \cdot 10^{-2}$ atm partial pressure. Then a given amount of sized limestone was added and the Teflon vessel was sealed immediately to be airtight (2). The calcium concentration which developed by disso-

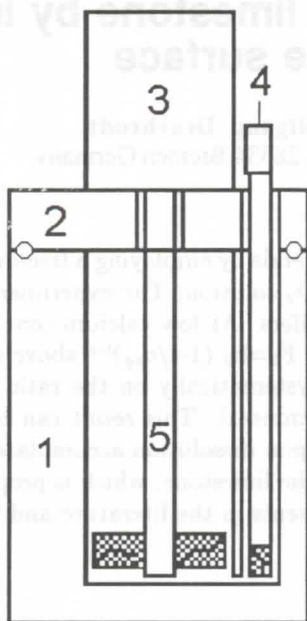

Figure 1: Schematic view of the experimental apparatus (see text).

lution was followed by measuring the conductivity (4) as a function of time for periods in the range of 3 up to 48 days, depending on the surface area of the added mineral. At the end of the run, the final calcium concentration was analysed by EDTA titration and ICP. Using the linear relation between the conductivity σ [μS] and the calcium concentration c [$\text{mmole} \cdot \text{l}^{-1}$], c is obtained as a function of time by the relation $c = 5.35 \cdot 10^{-3} \sigma - 0.053$ (DREYBRODT *et al.*, 1996). Calcite dissolution rates have been calculated using the relation:

$$R = V/A \cdot \frac{dc}{dt} \quad (3)$$

where V is the volume of water, A the surface area of limestone in contact with water. Units are mole, cm, s. Correspondingly concentrations are in mole $\cdot \text{cm}^{-3}$.

3. Results and discussion

We have measured dissolution rates for different V/A -ratios in the range from 0.15 up to 9 cm. The maximum V/A ratio was obtained by employing limestone disks. A typical experimental result of the observed limestone dissolution rates is shown in Fig. 2. By plotting logarithmically, dissolution rate versus $(1-c/c_{eq})$ a kinetic switch from a lower to a higher reaction order is well seen at c_s . This higher reaction order is independent of the stirring rate. Log dissolution rate was plotted against $\log(1-c/c_{eq})$ for more than 40 experiments. From these the empirical relations (1) and (2), n_1 , n_2 , k_1 , k_2 and c_s were found by regression analysis as shown in Fig. 2. The steep decrease of the rates at concentrations above c_s indicates that an inhibition mechanism is active. As a working hypothesis we assume that inhibitors, such as PO_4^{3-} are incorporated in the bulk of the limestone, and are absorbed to the actual surface, when they become

mobile during desintegration of the lattice by dissolution. In that case the concentration of these inhibitors at the surface should be dependent on the depth d of the layer removed by dissolution. This is related to the V/A -ratio by:

$$d = V/A \cdot c_{end} \cdot 0.037 \quad (4)$$

c_{end} is the concentration in mole $\cdot \text{l}^{-1}$, when the run was completed. From the considerations above one expects variations in the dissolution rate with increasing d . We have therefore measured the rates with varying V/A covering the region from $d \approx 0.2 \cdot 10^{-4}$ to $5 \cdot 10^{-4}$ cm for the particles and $d \approx 6 \cdot 10^{-4}$ cm for the disks. Fig. 3a,b, Fig. 4a,b and Fig. 5 depict the results of 42 dif-

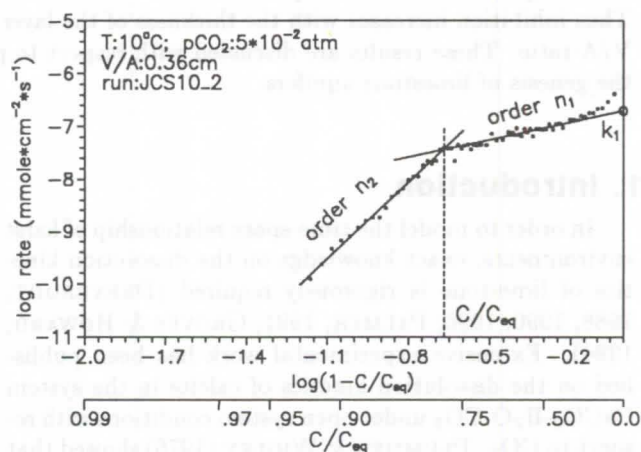

Figure 2: log of the dissolution rate versus $\log(1-c/c_{eq})$ for Jura limestone.

ferent runs, each point representing an average of about 2-8 identical experiments. As can be visualized from Fig. 3a,b, Fig. 4a,b and Fig. 5 all parameters show a similar variation with the thickness d removed from the mineral. After a steep increase within a few 10^{-4} cm (n_1 , n_2 , and k_2) or a steep decrease (k_1 and c_s) saturation is reached. This indicates that the surface concentration of the inhibitors also attains a saturation concentration, when all possible sites for absorption are occupied. It should be noted that the depth of $3 \cdot 10^{-4}$ cm corresponds to about 3000 atomic layers. With a concentration of 10^{-4} moles of inhibiting species per mole of limestone, and all of those absorbed at the surface, one expects a coverage of about 30%. We have also performed experiments on marble and flowstone deposited in a cave. First results indicate that the trends observed in the Jura limestone apply generally for all natural calcium carbonate minerals. There is a further consequence of the variation of the kinetic constants, especially c_s , n_2 and k_2 : Due to the effective inhibition of dissolution the approach to thermodynamic equilibrium with respect to calcite becomes infinitely slow and the solution attains an apparent quasi-equilibrium. Fig. 6 illustrates the apparent equilibrium concentration c_{app} as a function of d . After a steep decrease, beyond a value of about $1.5 \cdot 10^{-4}$ cm this concentration reaches a constant value $c_{app} \approx 1.78 \text{ mmole} \cdot \text{l}^{-1}$. The values of the apparent equilibrium concentration shown in Fig. 6

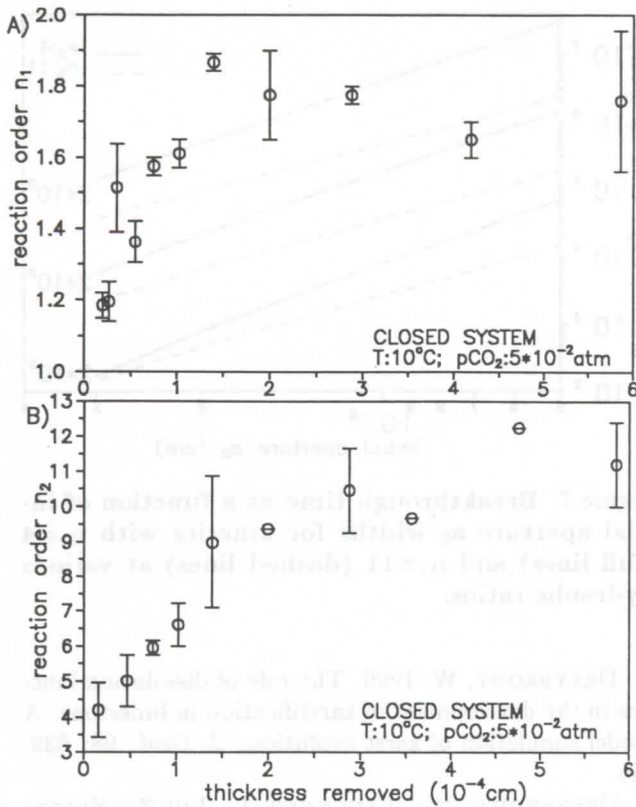

Figure 3: A) Reaction order n_1 as a function of removed limestone by dissolution. B) Reaction order n_2 as a function of removed limestone by dissolution.

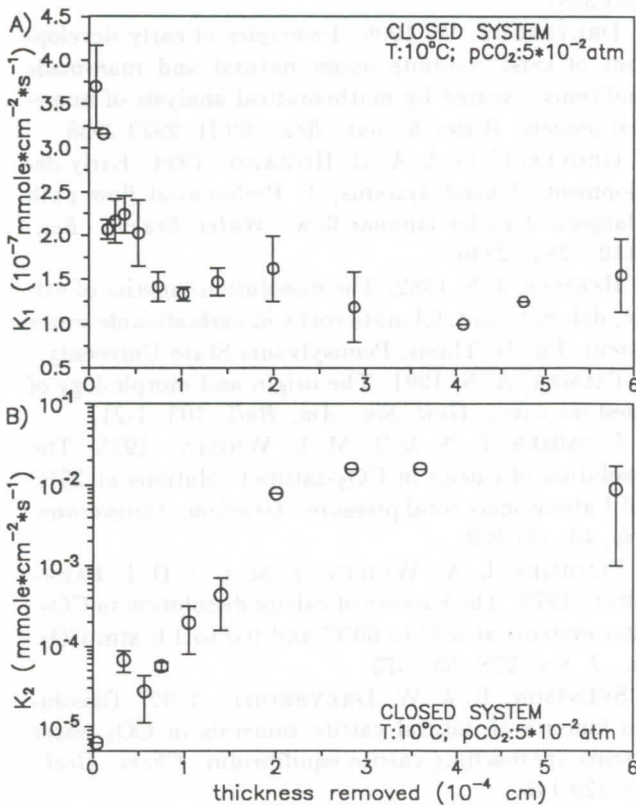

Figure 4: A) Kinetic constant k_1 as a function of removed limestone by dissolution. B) Kinetic constant k_2 as a function of removed limestone by dissolution.

correspond to dissolution rates below 10^{-14} mole \cdot cm² \cdot s⁻¹. Note the resemblance between the behaviours of the c_{app} (Fig. 6) and the kinetic parameters (Fig. 3a,b, Fig. 4a,b and Fig. 5). Recently we have performed sub-

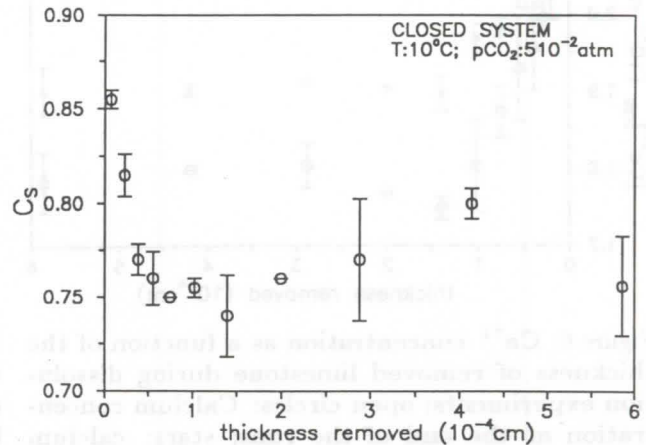

Figure 5: c_s as a function of the thickness of removed limestone by dissolution.

sequent dissolution experiments increasing the value of d with each repeated run on the same limestone under open system conditions with respect to CO₂ and under turbulent motion. The results, not shown here, are in good agreement with our interpretation. Previously, inhibition was observed also in open systems with $p_{CO_2} = 1$ atm by PLUMMER & WIGLEY (1976) and by HERMAN (1982). In a batch experiment PLUMMER & WIGLEY (1976) observed nonlinear kinetics with order $n_2=8$. Using a rotating disk technique ($V/A=60$ cm) HERMAN (1982) observed $n_2=10$. Summarizing we have found that the dissolution kinetics of natural calcium carbonate minerals depends on the depth of the layer already removed by dissolution. Therefore experimental data obtained from freshly broken material are not adequate to be used in discussing a real geological situation. Due to the accumulation of inhibitors, rates can be lower by orders of magnitude. Further work must be done to investigate the nature of the inhibitors and of the inhibition mechanism. To corroborate the existence of this inhibition effect one should note the fact, that it is missing completely in ultrapure synthetic calcite (NBS), which should be free of inhibitors. This has been observed by SVENSSON & DREYBRODT (1992), who showed that for this material the dissolution rates are well described by the rate equation of PLUMMER *et al.* (1978).

4. Implications to karst evolution

In the evolution of karst aquifers by calcite aggressive aqueous CO₂-solutions percolating through primary fractures of limestone rocks, one has to consider that layers of about several 10⁻⁴ cm will be removed from the freshly broken joint surfaces within a short time compared to the evolution of the karst conduit (DREYBRODT, 1996). Therefore the dissolution kinetics in the inhibited region with $n_2 \simeq 11$ seems to be more appropriate in modelling the early evolution of karst conduits. Up

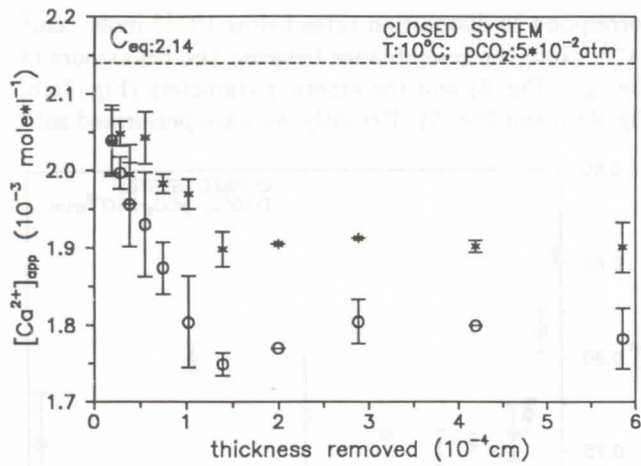

Figure 6: Ca^{2+} concentration as a function of the thickness of removed limestone during dissolution experiments; open circles: Calcium concentration at the end of the runs; stars: calcium concentration at dissolution rate: $10^{-11} \text{ mmole} \cdot \text{cm}^{-2} \cdot \text{s}^{-1}$.

to now dissolution rates with $n_2 = 4$ have been used in all these modelling efforts. We therefore have used our model (DREYBRODT, 1996) to calculate breakthrough times for a karst channel consisting of a plane parallel fracture with initial aperture widths a_0 from $5 \cdot 10^{-3} \text{ cm}$ up to $3 \cdot 10^{-2} \text{ cm}$ subject to an hydraulic ratio (l^2/h). l is the length of the fracture in [cm] and h the hydraulic h [cm] acting, to drive water through it. Thus $l=1 \text{ km}$ and $h=50 \text{ m}$ correspond to an hydraulic ratio of $2 \cdot 10^6 \text{ cm}$. Breakthrough times mark the end of early conduit evolution by a dramatic increase in the flow rates and are a measure for the intensity of karstification (DREYBRODT, 1988, 1990, 1996). In Fig. 7 the dashed curves give breakthrough times for the inhibited kinetics with $n_2=11$ taken from our experiments, for various values of a_0 and (l^2/h). The full lines illustrate the breakthrough times for the kinetics with $n_2=4$ taken from experiments obtained on freshly broken material (SVENSSON & DREYBRODT, 1992)

From this figure one can read that in cases, especially when karstification times are extremely large for kinetics with $n_2=4$ (e.g. $a_0 = 5 \cdot 10^{-3} \text{ cm}$, $l=10 \text{ km}$ and $h=50 \text{ m}$), these are reduced by one order of magnitude upon the action of the inhibition effect ($n_2=11$). Thus the evolution of karst aquifers over large distances of several km in joints with small aperture widths of about $50 \mu\text{m}$ becomes feasible in time scales of less than one million years. This shows that karstification is much less restricted than believed up to now, where aperture widths of at least 0.01 cm were supposed as a necessary condition for the evolution of large karst aquifers in geologically reasonable times.

References

DREYBRODT, W. 1988: Processes in karst systems-Physics, chemistry and geology. Springer Series in Physical Environment, Springer Berlin, New York, 288 p.

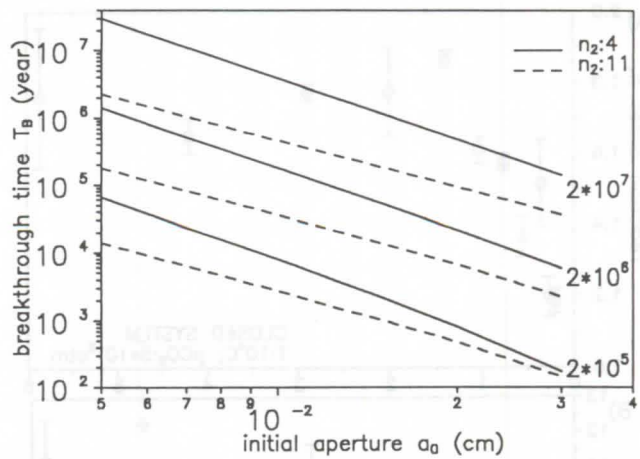

Figure 7: Breakthrough time as a function of initial aperture a_0 widths for kinetics with $n_2=4$ (full lines) and $n_2=11$ (dashed lines) at various hydraulic ratios.

DREYBRODT, W. 1990. The role of dissolution kinetics in the development of karstification in limestone: A model simulation of karst evolution. *J. Geol.*, 98: 639-655.

DREYBRODT, W.; LAUCKNER J.; LIU Z.; SVENSSON U. & B. BUHMANN 1996. The kinetics of reaction $\text{CO}_2 + \text{H}_2\text{O} \rightarrow \text{H}^+ + \text{HCO}_3^-$ as one of the rate limiting steps for the dissolution of calcite in the system $\text{H}_2\text{O}-\text{CO}_2-\text{CaCO}_3$. *Geochim. Cosmochim. Acta*, 60(18): 3375-3381.

DREYBRODT, W. 1996. Principles of early development of karst conduits under natural and man-made conditions revealed by mathematical analysis of numerical models. *Water Resour. Res.*, 32(9): 2923-2935.

GROVES, C. G. & A. D. HOWARD. 1994. Early development of karst systems, 1, Preferential flow path enlargement under laminar flow. *Water Resour. Res.*, 30(10): 2837-2846.

HERMAN, J. S. 1982. The dissolution kinetics of calcite, dolomite and dolomite rocks in carbondioxide water system. Ph. D. Thesis, Pennsylvania State University.

PALMER, A. N. 1991. The origin and morphology of limestone caves. *Geol. Soc. Am. Bull.*, 103: 1-21.

PLUMMER, L. N. & T. M. L. WIGLEY. 1976. The dissolution of calcite in CO_2 -saturated solutions at 25°C and 1 atmosphere total pressure. *Geochim. Cosmochim. Acta*, 40: 191-202.

PLUMMER, L. N.; WIGLEY, T. M. L. & D. L. PARKHURST. 1978. The kinetics of calcite dissolution in CO_2 -water systems at 5°C to 60°C and 0.0 to 1.0 atm CO_2 . *Am. J. Sci.*, 278: 537-573.

SVENSSON, U. & W. DREYBRODT. 1992. Dissolution kinetics of natural calcite minerals in CO_2 -water systems approaching calcite equilibrium. *Chem. Geol.*, 100: 129-145.

Acknowledgements We thank the Deutsche Forschungsgemeinschaft (W.D. and B.M.) and the Fonds national de la recherche scientifique suisse (L.E.) for financial support.

Abondance et origine des composés carbonés inorganiques des sources karstiques du Languedoc-Roussillon

par Jean Pierre Faillat

Laboratoire d'Hydrogéologie, ISAMOR, Technopôle Brest-Iroise, 29280 Plouzané, France

Abstract

The compilation and interpretation of hydrochemical data (major constituents) from 650 karstic springs of Languedoc-Roussillon, recently completed with physico-chemical, chemical and isotopic analysis of $\delta^{13}\text{C}$ -TDIC vs PDB of about thirty springs, allow to settle levels of "anomalies" for HCO_3^- , pCO_2 and pH above which deep CO_2 is necessary to explain the HCO_3^- concentrations. Diversity of the sources of this deep CO_2 is placed in a prominent position, the factors of control are indexed and their relative importance briefly evaluated.

Résumé

La compilation et l'interprétation de données hydrochimiques (ions majeurs) anciennes concernant 650 sources karstiques du Languedoc-Roussillon, complétés récemment par des suivis physico-chimiques et chimiques et par des analyses isotopiques du $\delta^{13}\text{C}$ -CITD vs PDB sur une trentaine de ces sources, a permis de fixer des seuils "d'anomalies" pour HCO_3^- , pCO_2 et le pH, au delà desquels l'intervention de CO_2 "profond" est nécessaire pour expliquer les concentrations en HCO_3^- observées. La diversité des origines de ce CO_2 profond est mise en évidence, les facteurs de contrôle sont répertoriés et leur importance relative évaluée.

1. Introduction

Les implications médicales ou économiques de fortes teneurs en bicarbonates associées au dioxyde de carbone dans les eaux souterraines, ont depuis longtemps suscité des études en grand nombre. Celles-ci portent indifféremment sur des milieux sédimentaires ou endogènes. Dans cette note, située en Languedoc-Roussillon, seul le milieu sédimentaire carbonaté est pris en compte directement, puisque ne sont utilisées que des sources karstiques, au nombre de 650 (PURADIMAJA, 1991) et de quelques forages. Le choix de cette échelle d'observation et de milieu est justifié par le souci d'une approche systématique, non orientée; de généralisation et d'homogénéité des données traitées. Le but de ce travail est de déterminer l'origine du bicarbonate et du dioxyde de carbone dans les eaux karstiques et de reconnaître les facteurs qui influent sur leurs concentrations et compositions isotopiques.

2. Contexte régional

Hormis sur sa périphérie montagneuse, le Languedoc-Roussillon est soumis à un climat méditerranéen. De géologie complexe, on retiendra que l'on y trouve d'épaisses séries carbonatées (jusqu'à 1000 m d'épaisseur d'un seul tenant) intensément fracturées lors des phases tectoniques du Cénozoïque. Elles permettent l'existence de puissants aquifères karstiques, cela d'autant plus qu'il y a eu plusieurs occasions favorables à leur développement depuis le Crétacé : climat tropical à certaines époques du Cénozoïque, régressions importantes abaissant le niveau marin du Messinien au Quaternaire, et enfin, tectonique distensive, notamment à l'Oligocène et au Miocène. Lors de la phase de compression alpine, au Miocène supérieure, se produit le début de l'exhaussement des zones montagneuses, mouvement qui se prolonge actuellement. Il y aura des zones saturées à réserves permanentes sous le niveau des émergences, grâce aux structures plissées, effondrées ou ennoyées par des sédiments argilo-sableux. Par contre, les structures exhausées tectoniquement et/ou isolées par l'érosion ne permettront que la réalisation de karsts perchés, à réserves régulatrices situées au-dessus des émergences, principalement en zone non saturée. Du fait de la diversité extrême des conditions hydrogéologiques et du grand nombre de sources utilisées, les caractéristiques de celles-ci sont également très variées, avec notamment des altitudes d'émergence de -31m à 2250m et des débits d'étiage de 0 à 800 l.s^{-1} .

3. Méthodologie

Les données physico-chimiques et chimiques utilisées proviennent de 57 études de natures diverses réalisées entre 1964 et 1992. Elles sont la base d'un inventaire de 650 sources karstiques (PURADIMAJA, 1991; FAILLAT & PURADIMAJA, 1995), complétées par 30 forages. Un lot de 32 sources a été suivi tout particulièrement pour élargir les informations fournies par cet inventaire.

Des valeurs de $\delta^{13}\text{C}$ du carbone inorganique total dissous ($\text{CITD} = \text{CO}_3^{--} + \text{HCO}_3^- + \text{CO}_2$) proviennent d'études aux environs de Montpellier (YERRIAH, 1986, GRILLOT & BLAVOUX, 1986). Les points d'eau concernés étaient très typés par leur situation géologique (proximité de grandes failles crustales) et leurs caractéristiques hydrochimiques et gazeuses. Aussi, pour compléter ces données, il a été fait en 1989 (PURADIMAJA, 1991) puis en 1991 (ESTIVAL, 1991), 14 prélèvements sur des sources ou des forages karstiques ordinaires. Sept sont situés sur le versant sud-est du Massif de la Gardiole, cinq autres, à débits faibles, avec des températures de 14 à 18°C, dans une région à anomalies en HCO_3^- du

Crétacé au Nord de la faille de Nîmes. Les deux autres prélèvements ont été pris dans deux sources côtières des Corbières (23, 37), fortement marquées par un apport lagunaire et par de légères anomalies thermiques positives. A cela viennent s'ajouter 6 valeurs concernant les Corbières, obtenues en 1987 (BAKALOWICZ, 1988). Les prélèvements ont été recueillis dans des flacons en polyéthylène de 250 cc. Deux centimètres cubes de NaOH à 2 N sans CO₂ ni sulfate de fer et un excès de BaCl₂ ont été rajoutés à l'eau immédiatement et le flacon bouché avec soin. Les dosages du ¹³C ont été réalisés au laboratoire d'Hydrologie et de Géochimie isotopique de l'Université de Paris-Sud.

4. Données disponibles sur les eaux karstiques

Dans le cadre de ce travail, seuls HCO₃⁻, pCO₂ et le pH sont employés. Leurs distributions statistiques sont données dans la figure 1. La teneur en CO₂ dissous est le principal facteur de contrôle des équilibres calco-carboniques. C'est aussi celui dont il est le plus difficile de donner des ordres de grandeur transposables à l'échelle d'un système hydrogéologique karstique, à cause de la grande hétérogénéité de sa distribution spatiale et temporelle. Une centaine de sources de la région possèdent des données qui permettent le calcul de la pCO₂. Cependant, après élimination des données douteuses ou des eaux excessivement minéralisées, seules 73 ont pu être employées. L'essentiel des valeurs varie de 0.001 à 0.5 atmosphère, pour cet échantillon statistique réduit. Deux modes apparaissent, vers 0.006 et vers 0.02. Les teneurs moyennes en HCO₃⁻ (650 données disponibles) peuvent varier de 0.5 à 20.0 meq.l⁻¹, avec un mode à 4-6 meq.l⁻¹ (350 données). En ce qui concerne le pH, 203 sources ont des valeurs moyennes s'étendant de 6,5 à 8,3, avec un mode à 7,4-7,6.

Au total, 29 valeurs de δ¹³C-CITD sont disponibles, qui correspondent directement ou indirectement à des eaux de nappes karstiques, prélevées dans des forages ou des sources, les aquifères principaux étant crétacés ou jurassiques. Les δ¹³C-CITD varient de -2,5 à -15,4 ‰ vs PDB (tableau 1).

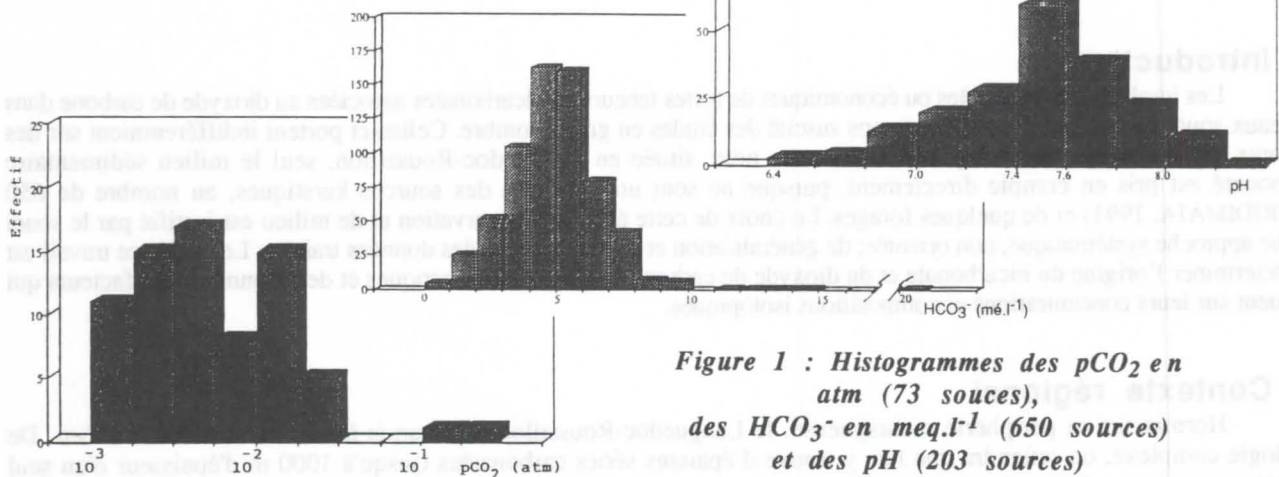

Figure 1 : Histogrammes des pCO₂ en atm (73 sources), des HCO₃⁻ en meq.l⁻¹ (650 sources) et des pH (203 sources)

N°	NOM	Régions	T°C	pHT	HCO3	pCO2 atm	13C	Formation	Origine
F1	F. Font d'Aurelle	Montpellier		6.80	6.80	0,022	-12.60	Pliocène	YERRIAH, 1986
F2	F. ENSA	"		6,70	7,80	0,033	-14.20	"	"
F3	F. USTL début	"		6,75	7,20	0,031	-9.90	Oligocène	"
F3	F. USTL fin	"			12,00		-2.50	"	"
F4	F. Av. d'Occitanie	"		7,30	5,80	0,018	-11,30	Jurassique	"
F5	F. Aiguelongue	"		6,65	9,60	0,104	-6,70	"	"
627	La Roubine	Gardiolo		6,30	12,90	0,059	-7,00	"	"
625	La Madeleine	"		6,40	12,10	0,144	-5,70	"	"
626	Font Forte	"		6,20	19,50	0,425	-4,10	"	"
55	La Mouillère	Corbières	24,1	7,11	3,36	0,014	-10,80	Crétacé	BAKALOWICZ, 1988
56	La Fou	"		26,1	6,35?	3,10	0,074?	-8,60	"
62	Las Doux	"		13,2	7,33	4,46	0,011	-12,50	"
83	Fouradade	"		21,0	6,93	3,56	0,019	-13,10	"
94	Font des Aygues	"		22,0	6,95	4,56	0,027	-13,40	Jurassique
147	Capt. Caramany	"		18,7	6,80?	4,40	0,037?	-7,80	Crétacé
23	Croix St-Vincent	"		20,6	7,40	5,80	0,011	-8,47	"
37	La Valentine	"		18,5	7,04	5,99	0,025	-9,40	"
815	Mas Planta	Nîmes	20,5	6,96	6,78	0,04	-11,38	Jurassique	"
817	Captage de Liouc	"		13,8	7,14	7,06	0,026	-14,26	Crétacé
873D	St-Clément	"		14,3	6,88	6,76	0,045	-14,49	"
887	Fontaran	"		14,0	6,95	8,33	0,047	-15,41	"
924	Fanlade	"		13,9	6,90	7,66	0,048	-15,28	"
G9	Grotte	Gardiolo	15,8	6,94	6,50	0,037	-10,00	Jurassique	ESTIVAL, 1991
C15	F. Fillot	"		16,5	6,70	8,60	0,092	-9,90	"
C23	F. Chambon	"		16,2	6,68	8,20	0,085	-11,63	"
G25	F. Sicard	"		14,6	6,61	11,05	0,131	-7,38	"
G28	F. V3	"		15,2	6,79	7,30	0,065	-11,52	"
G30	F. Remy	"		15,4	7,15	5,60	0,02	-13,73	"
G31	F. Karland	"		15,5	6,60	10,50	0,13	-7,55	"

Tableau 1 : Données chimiques et isotopiques concernant les sources karstiques dosées pour le δ¹³C-CITD

5. Interprétation et discussion

Dans l'air atmosphérique, la tension en CO_2 est de 0.0003 atm en moyenne. Ce sera celle de l'eau de pluie et d'une manière générale, de toute eau largement au contact de l'air atmosphérique, depuis un temps suffisant pour que l'équilibre soit atteint (cours d'eau). Une telle tension de CO_2 ne permet d'atteindre qu'une concentration de 2 meq.l⁻¹ en HCO_3^- , valeur presque toujours dépassée par les eaux en milieu carbonaté. Aussi, l'origine la plus fréquente et la plus largement admise du CO_2 des eaux est l'air des sols (TROMBE, 1952; SCHOELLER, 1962, 1969; ROQUES, 1963; RENAULT, 1968, 1971, 1972; RIGHTMIRE & HANSHAW, 1973; BAKALOWICZ, 1979; etc...). En fonction des teneurs en CO_2 rencontrées le plus souvent dans ceux-ci en certains points, ainsi que dans les eaux, et en tenant compte d'un effet d'échelle, nous avons retenu un seuil d'anomalie en pCO_2 égal à 0.03 atmosphère pour les émergences karstiques du Languedoc-Roussillon. Il est intéressant de constater qu'une telle valeur de pCO_2 correspond, pour une eau à 10-20°C, très nettement bicarbonatée calcique, à l'équilibre vis-à-vis de la calcite, à des teneurs en HCO_3^- de 6-7 meq.l⁻¹ et un pH de 6,9-7,1. Cela, joint à l'allure de la distribution statistique des valeurs de HCO_3^- et des pH (figure 1) nous amène à fixer à ces valeurs les seuils d'anomalie. On suppose que pour dépasser ces seuils (HCO_3^- , pCO_2 et H^+) un apport de CO_2 à forte pression partielle est toujours nécessaire. Cela ne signifie cependant pas que du CO_2 profond ne participe jamais à la formation de HCO_3^- au-dessous du seuil 6,9-7,1 meq.l⁻¹, mais il n'est pas alors absolument nécessaire pour expliquer la concentration atteinte. Dans ce travail, le CO_2 du sol sera la source dite "normale" en ce composé.

Pour préciser l'origine multipolaire du CO_2 qui a participé aux équilibres calco-carboniques, il sera fait appel au $\delta^{13}\text{CITD}$, dont les ordres de grandeurs ont été compilés pour différents milieux (CRAIG, 1953; RANKAMA, 1963; PILOT, 1974; BARNES, 1979; HOEFS, 1987) et reportés dans la figure 2.

Celle-ci montre qu'il y a globalement une relation entre le $\delta^{13}\text{CITD}$ d'une part, et d'autre part HCO_3^- . Les 29 points représentatifs adoptent cependant l'allure d'une croix, qui indique une origine multipolaire du carbone. La branche A correspond à des eaux dont le carbone est enrichi en ^{13}C et cela d'autant plus que HCO_3^- et pCO_2 sont forts et le pH faible. Il s'agit là de la classique courbe de mélange qui met en compétition le CO_2 du sol et le CO_2 profond magmatique ou métamorphique (FONTES et al., 1963; ALLARD, 1979; PILOT, 1974; FRICKE, 1978; etc...). Des valeurs aussi fortes pourraient aussi s'expliquer par la fermentation méthanique d'après BLAVOUX et LETOLLE (1995). Ce mécanisme était déjà proposé par WIGLEY et al. (1978), en plus de celui de précipitations et dissolutions concomitantes (WIGLEY, 1976), qui peuvent mener à des $\delta^{13}\text{C}$ de l'ordre de -5 à -3‰, mais sans accroissement de la quantité de carbone, ce qui n'est pas le cas ici.

La branche B correspond à des eaux (817, 887, 924) au delà du seuil d'anomalie en HCO_3^- , mais sans enrichissement en ^{13}C . Le pôle distal responsable de la position de cinq points est dû au CO_2 profond biogénique produit par la matière organique fossile.

La branche C, peu marquée, est matérialisée par les deux sources littorales (23 et 37). Le mélange de l'eau karstique avec de l'eau d'étang à fort $\delta^{13}\text{C}$ -CITD mais peu de HCO_3^- peut entraîner un déplacement de ces points hors de la courbe de mélange A, avec de plus modifications des concentrations des espèces carbonatées, de l'équilibre et du pH (WIGLEY et PLUMMER, 1976). Ici, le CO_2 excédentaire doit être profond et inorganique. La position des points 56 et 147 pourrait s'expliquer par la dissolution de gypse par de l'eau à l'équilibre avec la calcite, ce qui permettrait la dissolution de dolomite et la précipitation de calcite (WIGLEY, 1978). 80% d'apport en gypse suffirait à expliquer les $\delta^{13}\text{C}$ observés, mais toutes les eaux du même type ne semblent pas concernées...

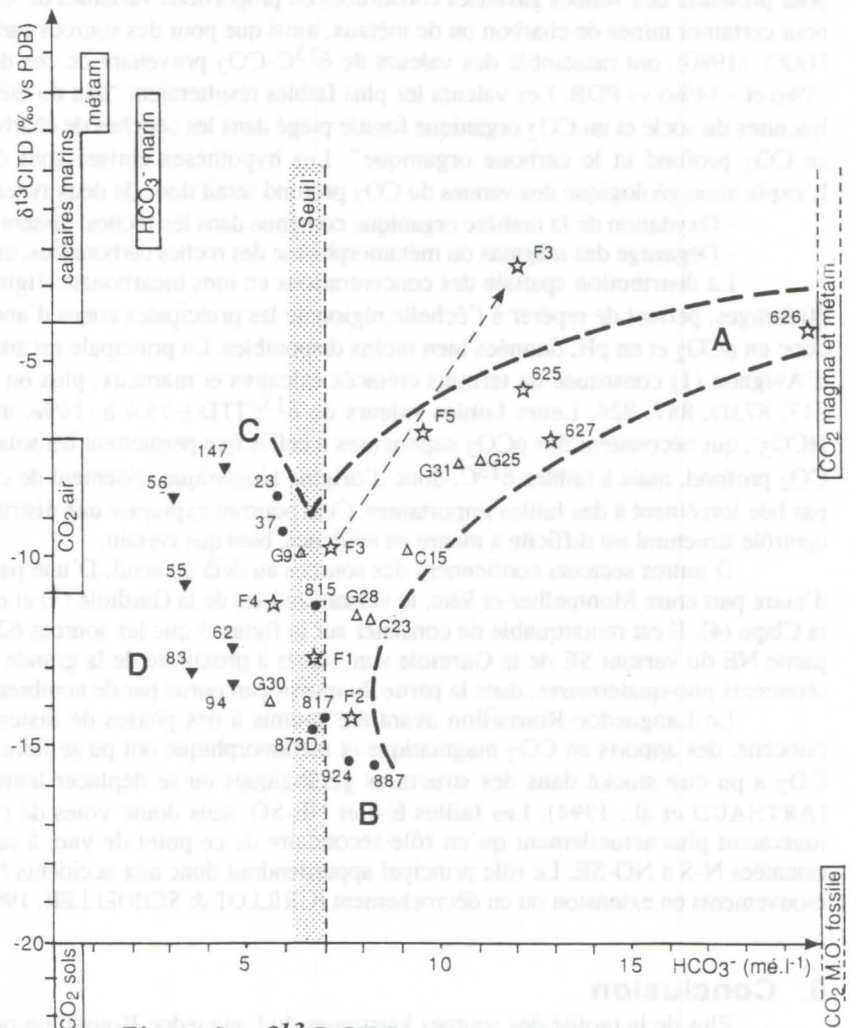

Figure 2 : $\delta^{13}\text{C}$ -CITD (‰ vs PDB) en fonction des HCO_3^- en meq.l⁻¹ avec indication des domaines de variation des $\delta^{13}\text{C}$ de divers composés carbonés

Enfin, la branche D, mal définie, est le domaine des eaux karstiques banales, les plus nombreuses, bien que peu représentées ici, car très rarement choisies. Le CO₂ qui intervient dans les équilibres calco-carboniques de ces dernières provient très majoritairement du CO₂ produit dans le sol et peu de l'air atmosphérique.

Malgré l'origine plurimodale du carbone et les mélanges possibles, la complexité des processus isotopiques (effets isotopiques, fractionnement), chimiques et biochimiques (cinétique, dissolution-précipitation, variations de température, dégazage du CO₂, conditions redox, confinement) mis en jeu, qui toutes peuvent dans certaines conditions mener à un enrichissement isotopique (WIGLEY, 1976 et 1978), les eaux les plus caractéristiques peuvent être identifiées en ce qui concerne l'origine de leur carbone, surtout si l'on tient compte d'un ensemble de paramètres, tels que pH, Eh, t°, pCO₂, ions majeurs... Il est remarquable qu'aucun point ne tombe entre les branches A et B, ce qui semble indiquer, pour l'échantillon disponible, que l'une ou l'autre source de CO₂ profond dominera exclusivement. Cela pourrait être dû à la plus grande profondeur des apports en CO₂ magmatiques et métamorphiques, qui, là où ils sont en contact avec la matière organique fossile des ensembles sédimentaires lors de leur trajet vers la surface, s'appauvriraient en ¹³C par échange avec celle-ci.

Des travaux régionaux récents, dont ceux de GRILLOT & YERRIAH-MASSON (1986), GRILLOT & SCHOELLER (1989), BLAVOUX & DAZY (1990) et d'ARTHAUD et al. (1994), apportent des renseignements sur la présence de CO₂ profond entre Rhône et Pyrénées. Près d'une vingtaine de forages pouvant atteindre 5000 mètres de profondeur sont connus pour présenter des venues gazeuses constituées en proportions variables de CO₂ et CH₄ et d'autres gaz. Il en est de même pour certaines mines de charbon ou de métaux, ainsi que pour des sources carbo-gazeuses du socle varisque. BLAVOUX et DAZY (1990), ont rassemblé des valeurs de δ¹³C-CO₂ provenant de ces divers milieux. Ces δ¹³C sont compris entre -3‰ et -14‰ vs PDB. Les valeurs les plus faibles résulteraient "soit du mélange entre CO₂ profond s'échappant par les fractures du socle et un CO₂ organique fossile piégé dans les couches de charbon, soit d'un simple échange isotopique entre ce CO₂ profond et le carbone organique". Les hypothèses émises sont donc en accord avec celles de ces auteurs. L'explication géologique des venues du CO₂ profond serait donc de deux types principaux :

- Oxydation de la matière organique contenue dans les roches, disséminée ou en gisements (charbon, pétrole).
- Dégazage des magmas ou métamorphisme des roches carbonatées, et remontée du gaz à la faveur d'accidents.

La distribution spatiale des concentrations en ions bicarbonate (figure 3), disponibles pour les 650 sources et les 30 forages, permet de repérer à l'échelle régionale les principales zones d'anomalies en HCO₃⁻ (70 sources et forages), et donc en pCO₂ et en pH, données bien moins disponibles. La principale est située dans la région des Garrigues de Nîmes et d'Avignon (1) constituée de terrains crétacés calcaires et marneux, plus ou moins plissés. On y trouve les sources 815, 817, 873D, 887, 924. Leurs faibles valeurs de δ¹³CITD (-15.4 à -14‰, une seule à -11‰), et les teneurs élevées en HCO₃⁻, qui nécessitent des pCO₂ supérieures à celles que permettent les sols à l'échelle régionale, exigent des apports en CO₂ profond, mais à faibles δ¹³C, donc d'origine biogénique (gisement de charbon, de pétrole...). Une telle origine n'est pas liée forcément à des failles importantes. Cela pourrait expliquer une distribution spatiale apparemment aléatoire dont le contrôle structural est difficile à mettre en évidence, bien que certain.

D'autres secteurs contiennent des sources au delà du seuil. D'une part dans la région entre Béziers et Lodève (2), d'autre part entre Montpellier et Sète, le versant sud-est de la Gardiole (3) et entre Narbonne et la mer, le Sud du Massif de la Clape (4). Il est remarquable de constater sur la figure 3 que les sources 625, 626, 627 et les forages peu profonds de la partie NE du versant SE de la Gardiole sont situés à proximité de la grande faille normale de Nîmes, cachée par d'épais sédiments plio-quadernaires, dans la partie du massif parcourue par de nombreuses failles N-S.

Le Languedoc-Roussillon ayant été soumis à des phases de distension avec amincissement crustal à l'Oligo-miocène, des apports en CO₂ magmatique et métamorphique ont pu se faire à cette occasion (GRILLOT et al., 1983). Ce CO₂ a pu être stocké dans des structures géologiques ou se déplacer lentement à travers l'épaisse série sédimentaire (ARTHAUD et al., 1994). Les failles E-O et NE-SO, sans doute voies de cheminement privilégiées à cette époque, ne joueraient plus actuellement qu'un rôle secondaire de ce point de vue, à cause des contraintes horizontales maximales orientées N-S à NO-SE. Le rôle principal appartiendrait donc aux accidents N-S à NO-SE, qui bénéficient de nos jours de mouvements en extension ou en décrochement (GRILLOT & SCHOELLER, 1989).

6. Conclusion

Plus de la moitié des sources karstiques du Languedoc-Roussillon présentant des anomalies hydrochimiques sont dans ce cas du fait des bicarbonates. Les pCO₂ calculées pour atteindre de telles concentrations sont incompatibles avec les pCO₂ en grand des sols. Les excédents de CO₂ nécessaires ne peuvent avoir, pour l'essentiel, qu'une origine profonde. Les teneurs en ¹³C du CITD montrent que cette origine profonde peut être variable, soit en relation avec du carbone biogénique (charbon, pétrole, etc...) à δ¹³C faibles, soit avec du carbone minéral, magmatique ou métamorphique, à δ¹³C forts. Dans le premier type d'apport profond "magmatique" et "métamorphique", le δ¹³C des sources karstiques peut être supérieur à -10‰, et dans le second type d'apport profond "biogénique" fossile, le δ¹³C des sources sera inférieur à -10‰, en première approximation. Des δ¹³C inférieurs à -10‰ ne signifient donc pas obligatoirement une origine biogénique superficielle, mais peuvent indiquer des apports en CO₂ biogéniques fossiles profonds, surtout si les teneurs en HCO₃⁻ sont au-dessus du seuil de 6,9-7,1 meq.l⁻¹. En fait, les mélanges en provenance de différentes sources de carbone et les processus en jeu peuvent être plus complexes pour certains points. Il ne sera donc pas toujours possible de proposer des origines déterminées pour le δ¹³C de certaines sources. Dans les Garrigues de Nîmes et de Montpellier, il semble que ces différents apports puissent jouer un rôle dans de nombreuses sources et dans les nappes karstiques qui les alimentent. On est en droit

de se demander si l'augmentation des valeurs de pCO_2 vers le bas dans nombre de cavités (RENAULT, 1972) ne s'expliquerait pas principalement par une telle origine. Ce phénomène serait alors généralisable à d'autres régions karstiques limitrophes du Massif Central, tels le Quercy et le Périgord, où des valeurs de pCO_2 supérieures à 0.03 peuvent être observées dans l'atmosphère du fond des grottes et avens. Le dosage du $\delta^{13}C-CO_2$ de l'air des cavités devrait permettre de tester cette hypothèse, si les difficiles conditions de prélèvement le permettent.

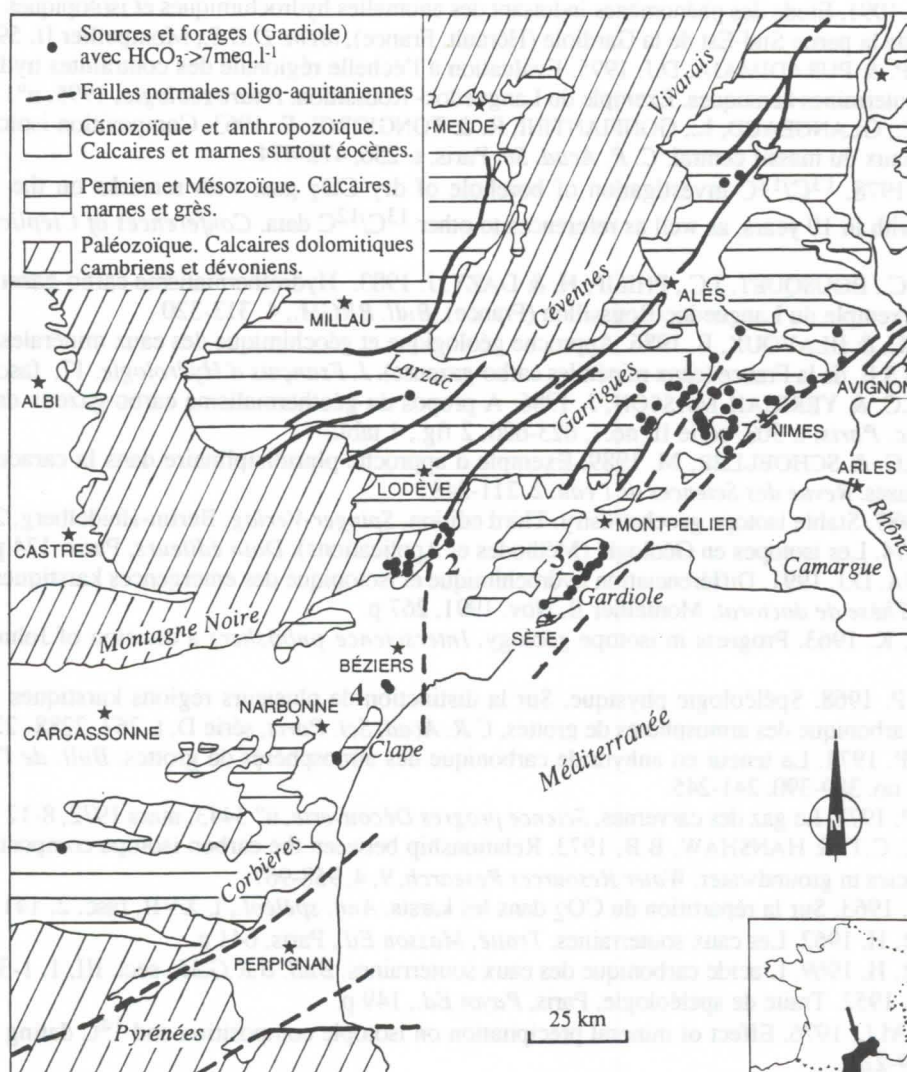

Figure 3 : Carte de localisation des sources karstiques du Languedoc-Roussillon et de forages (Gardiole) ayant des concentrations en HCO_3^- supérieures à 7 meq.l^{-1}

Remerciements :

Ceux-ci s'adressent au Professeur W. BALDERER pour ses remarques pertinentes qui ont permis d'améliorer l'interprétation des données.

Références

- ALLARD, P. 1974. $^{13}C/^{12}C$ and $^{34}S/^{32}S$ ratios in magmatic gases from ridge volcanism in Afar. *Nature*, 282, 56-58.
- ARTHAUD, F.; DAZY, J. & GRILLOT, J.C. 1994. Distribution of deep carbon dioxide in relation to the structure and tectonic evolution of south-east France. *Geodynamica Acta*, Paris, 7, 2, 86-102
- BAKALOWICZ, M. 1979. Contribution de la géochimie des eaux à la connaissance de l'aquifère karstique et de la karstification. *Thèse Doc.Sc.nat.*, Paris 6, 257 p.
- BAKALOWICZ, M. 1988. Géochimie des sources carbonatées des Corbières et formations de travertins, U.A. 903, C.N.R.S. et A.T.P. Piren, Aix-en-Provence, 209-225

- BARNES H.L. 1979. Géochimie de hydrothermal ore deposits. Second edition, A. Wiley- Interscience publication, John Willey & Sons, New York, 567 p.
- BLAVOUX, B. & DAZY, J. 1990. Caractérisation d'une province à CO₂ dans le bassin du Sud-Est de la France. *Hydrogéologie*, 4, 241-252
- BLAVOUX, B. & LETOLLE, R. 1995. Apports des techniques isotopiques à la connaissance des eaux souterraines. *Géochronique*, 54, 12-15
- CRAIG, H. 1953. The geochemistry of the stable isotopes. *Geochim. Cosmochim. Acta*, 3, 53-92
- ESTIVAL, V. 1991. Etude des phénomènes induisant des anomalies hydrochimiques et isotopiques dans les eaux de magasins carbonatés de la partie Sud-Est de la Gardiole (Hérault, France), *Mém. D.E.S.*, Montpellier II, 59 p.
- FAILLAT, J.P. & PURADIMAJA, D.J. 1995. Evaluation à l'échelle régionale des contraintes hydrochimiques sur la gestion des eaux souterraines karstiques. Exemple du Languedoc- Roussillon. *Hydrogéologie*, 1995, n°1, 97-112
- FONTES, J.C., GLANGEAUD, L., GONFIANTINI, R. & TONGIORGI, E. 1963. Composition isotopique et origine des eaux et gaz thermaux du massif central. *C. R. Acad. Sc. Paris*, t. 256, 472-474
- FRICKE, K. 1978. ¹³C/¹²C investigation of borehole of dry CO₂ gas, with remarks on the development of output and pressure with in 10 years, as well as references to other ¹³C/¹²C data. *Conferences of Cieplice SPA (Poland)*, Warsaw, 204-211.
- GRILLOT, J.C., BOUSQUET, J.C., PHILIP, H. & DAZY, J. 1983. Hydrothermalisme carbo-gazeux, radio activité et sismotectonique : exemple du Languedoc-Roussillon (France). *Bull. BRGM.*, 4, 313-320
- GRILLOT, J.C. & BLAVOUX, B. 1986. Approche géologique et géochimique des eaux minérales carbo-gazeuse : quelques exemples du S.E. de la France (eaux minérales carbo-gazeuse). *J. Français d'Hydrologie*, 17, fasc. 3, 263-272
- GRILLOT, J.C. & YERRIAH-MASSON, J. 1986. A propos du géothermalisme carbo-gazeux dans le S.E. de la France. *C.R. Acad. Sc. Paris*, t. 303, série II, no.7, 623-626, 2 fig., 1 tabl.
- GRILLOT, J.C. & SCHOELLER, M. 1989. Exemple d'approche pluridisciplinaire dans la caractérisation d'eaux thermales carbo-gazeuses. *Revue des Sciences de l'eau*, 2, 211-248
- HOEFS, J. 1987. Stable isotope geochemistry. Third edition, *Spinger-Verlag*, Berlin-Heidelberg, 241 p.
- PILOT, J. 1974. Les isotopes en Géologie (Méthodes et Applications). *Doin éditeurs*, Paris, 174 p.
- PURADIMAJA, D.J. 1991. Différenciation hydrochimique et isotopique des émergences karstiques du Languedoc-Roussillon (France). *Thèse de doctorat*, Montellier II, Nov. 1991, 267 p.
- RANKAMA, K. 1963. Progress in isotope geology. *Interscience publishers a division of John Wiley & Sons*, New York, 188-245
- RENAULT, P. 1968. Spéléologie physique. Sur la distinction de plusieurs régions karstiques en raisons de la teneur en anhydride carbonique des atmosphères de grottes. *C.R. Acad. Sci. Paris*, série D, t. 267, 2288- 2290.
- RENAULT, P. 1971. La teneur en anhydride carbonique des atmosphères de grottes. *Bull. de l'Association des Géographes français*, no. 389-390, 241-245.
- RENAULT, P. 1972. Le gaz des carvernes. *Science progres Découverte*, n° 3443, mars 1972, 8-12
- RIGHTMIRE, C.T. & HANSHAW, B.B. 1973. Relationship between the carbon isotope composition of soil CO₂ and the carbonate species in groundwater. *Water Resources Research*, 9, 4, 958-967
- ROQUES, H. 1963. Sur la répartition du CO₂ dans les karsts. *Ann. spéléol.*, t. XVII, fasc. 2, 141-184
- SCHOELLER, H. 1962. Les eaux souterraines. *Traité, Masson Ed.*, Paris, 641 p.
- SCHOELLER, H. 1969. L'acide carbonique des eaux souterraines. *Bull. B.R.G.M.*, sect. III, 1, 1-32.
- TROMBE, F. 1952. *Traité de spéléologie*, Paris, *Payot Ed.*, 149 p.
- WIGLEY, T.M.L. 1976. Effect of mineral precipitation on isotopic composition and ¹⁴C dating of groundwater. *Nature*, Vol. 263, 219-221.
- WIGLEY, T.M.L. & PLUMMER, L.N. 1976. Mixing of carbonate waters. *Geochim. Cosmochim. Acta*, 40, 989-995.
- WIGLEY, T.M.L., PLUMMER, L.N. & PEARSON, F.J. 1978. Mass transfer and carbon isotope evolution in natural water systems. *Geochim. Cosmochim. Acta*, 42, 1117-1139.
- YERRIAH, J. 1986. Le thermominéralisme carbo-gazeux du S.E. de la France (domaine sédimentaire) dans son contexte sismotectonique. *Thèse 3ème cycle*, Montpellier II, 108 p., 1 carte h.t.

Approche statistique de l'impact des variations climatiques sur la réponse chimique des sources karstiques

Par Domenico Alessandro Grasso & Pierre-Yves Jeannin

Centre d'hydrogéologie de l'Université, Rue Emile-Argand 11, CH-2007 Neuchâtel, Suisse

Résumé

Une méthode d'analyse statistique a été développée afin de tenter de détecter les facteurs les plus importants qui influencent la réponse chimique des sources karstiques. L'analyse en composantes principales a permis de déceler l'importante influence de l'état hydraulique du système (débit de la source) sur la réponse chimique. Une relation mathématique permet de simuler la variation du TAC en fonction du débit. Les écarts entre la chronique ainsi simulée et la chronique observée montrent l'existence de variations saisonnières qui semblent résulter des variations de la production de CO₂ dans les sols, c'est-à-dire dépendre du climat. Cette influence est cependant nettement subordonnée à celle du débit. La méthode présentée permet en principe de mettre en évidence l'influence d'autres paramètres sur la réponse chimique ou encore l'influence à long terme des variations climatiques.

Abstract

A statistical method has been developed to attempt to detect the factors playing a major role in the chemical response of karst springs. A principal component analysis (PCA) of the data illustrated the importance of the spring discharge (hydraulic conditions) on its chemistry. A mathematical relationship allows one to simulate the variation in alkalinity with respect to discharge. Residuals between the simulated and the observed time series shows that season depending processes (variations in CO₂ production in soils depending on climate) are also playing a role. Meanwhile, this role is clearly subordinate to the one of the discharge. The method presented here basically allows one to detect the influence of any other parameter on the water chemistry or also the long term influence of climate.

Introduction

La réponse chimique d'une source représente l'évolution dans le temps de l'ensemble des éléments chimiques dissous dans l'eau. Nous nous proposons d'évaluer l'effet des variations climatiques sur la réponse chimique des sources karstiques qui est fonction de plusieurs facteurs concomitants : hydrauliques, géologiques, climatiques, anthropiques, etc. Nous présentons ici une approche statistique qui a pour objectif de mettre en évidence les effets respectifs de chacun de ces processus. L'effet prédominant du débit (l'état hydraulique du système) sur la réponse chimique est étudié en premier, puis soustrait des réponses observées afin de mettre en évidence l'effet des autres paramètres et du climat plus particulièrement.

Données à disposition

Les données recueillies à la source de l'Areuse (NE, Suisse) ont principalement servi pour cette étude. Les données sont représentées par des mesures en continu, sur cinq années, du débit, de la température et de la conductivité électrique, ainsi que par des analyses mensuelles des éléments chimiques majeurs et des isotopes stables de l'eau. Les paramètres mesurés sont donc : débit, Temp., Cond, pH, TAC, Ca, Na, K, Mg, NO₃, Cl, SO₄. Les données chimiques mesurées par KIRALY & MULLER (1979) entre octobre 77 et septembre 79 ont également pu être utilisées. L'avantage de ces données est qu'elles présentent un échantillonnage très serré (900 analyses sur deux ans), fournissant des valeurs de débit, T, Cond, TAC, Ca, Na, K, Mg. L'Areuse prend naissance près du village de St-Sulpice, dans la partie orientale du Val-de-Travers, une importante vallée du Jura neuchâtelois (coordonnées 532'250/195'975/790 m). Le débit moyen annuel de la source est de 5.0 m³/s.

Analyse en composantes principales, effet de l'état hydraulique du système

Pour détecter l'influence respective de différents facteurs sur le comportement chimique des sources karstiques, il est nécessaire

de rechercher des corrélations entre ceux-ci et la réponse chimique de la source. Nous utiliserons l'analyse en composantes principales (ACP) appliquée aux séries d'analyses chimiques pour déceler les variations non aléatoires de la réponse chimique des systèmes karstiques.

Suivre l'évolution de la composition chimique d'une source revient à observer dans un espace à N dimensions (N égal au nombre de paramètres) la trajectoire dans le temps d'un point représentatif de sa composition. Dans notre analyse, nous avons retenu 12 paramètres : T, Cond, pH, TAC, Dto, Ca, Na, K, Mg, NO₃, Cl, SO₄.

L'ACP (DAVIS 1986) permet de remplacer l'espace défini par les 12 paramètres mesurés par un espace à douze dimensions dont les axes (facteurs) sont positionnés selon les directions d'allongement principales du nuage des points mesurés (vecteurs propres du nuage). Ces facteurs sont analytiquement indépendants (tous perpendiculaires les uns aux autres). Le premier facteur est positionné dans la principale direction d'allongement du nuage. Il représente ainsi le plus fort pourcentage de la variance totale du nuage. Chaque facteur consécutif représente un pourcentage de plus en plus faible de la variance totale du nuage.

Dans le cas de la source de l'Areuse, les cinq premiers facteurs représentent plus du 95% de la variance totale de la série. Ainsi, les plans factoriels formés du premier facteur couplé aux quatre autres ont été analysés.

L'axe factoriel I (ou F1) est bien corrélé avec tous les paramètres représentatifs de la minéralisation totale : les cations (surtout le Ca), la dureté totale, le TAC, la conductivité, et dans une moindre mesure les sulfates. On peut donc considérer le facteur I comme un axe "minéralisation". Le facteur II (ou F2) est représentatif surtout des Nitrates et du pH (dans une moindre mesure). Il peut donc être admis que ce facteur est lié à l'activité biologique dans les sols (dépendant du climat) et à l'activité anthropique.

Seul le plan factoriel défini par les axes I et II a permis de mettre en évidence des variations non aléatoires de la réponse chimique.

Pour analyser l'effet éventuel du débit sur la chimie des eaux, l'hydrogramme des sources karstiques a été schématiquement décomposé en quatre "états hydrauliques" différents : la montée, la décrue rapide, la période de transition, le tarissement.

A partir de cette distinction, la figure 1 montre qu'il existe une relation nette entre l'état hydraulique et la minéralisation, c'est-à-dire entre le temps de séjour de l'eau dans le système et sa minéralisation. En effet, le nuage des analyses correspondant à la décrue rapide est placé dans la partie gauche du plan factoriel (F1 - F2); les points ont donc des valeurs faibles selon F1, ce qui correspond à une faible minéralisation. Ces eaux ont des temps de séjour très faibles et n'ont pas pu atteindre un équilibre chimique avec les roches encaissantes. Au fur et à mesure que le débit diminue, le nuage des observations se déplace vers la droite dans le plan factoriel. Des eaux avec une minéralisation de plus en plus importante sont évacuées, ce qui correspond à des temps de séjour de plus en plus longs et peut être expliqué par la vidange des zones à perméabilité de plus en plus faible.

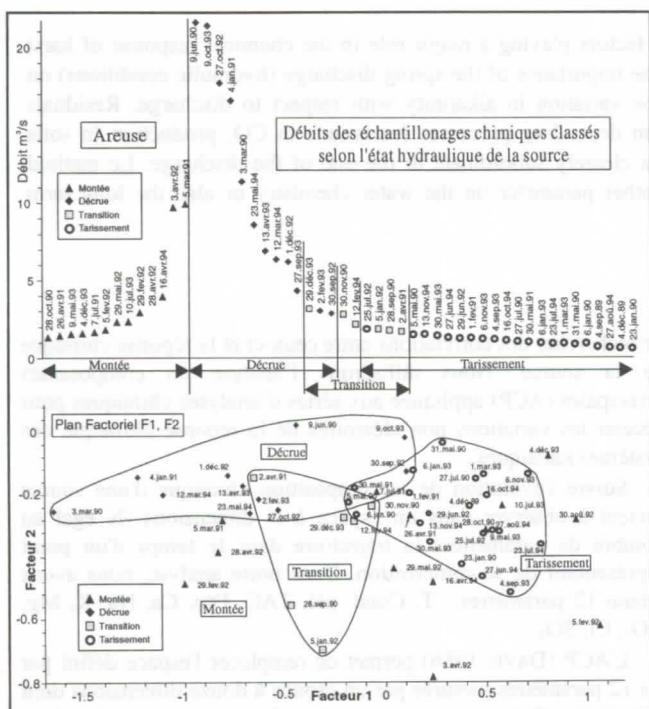

Figure 1 : La comparaison entre les deux graphiques montre la corrélation existante entre l'état hydraulique du système (fig. a) et la minéralisation à la source (fig. b).

Le report, sur le plan factoriel, des analyses chimiques prises pendant la montée des crues, montre une forte dispersion qui ne peut pas être mise en relation avec le débit seulement. Cette dispersion est liée à la poussée des eaux stockées antérieurement dans le système par les eaux des précipitations (effet piston). Cet effet dépend du comportement hydraulique propre du système, des facteurs externes comme l'intensité de la pluie et de l'état hydraulique du système avant la crue.

La présence de nuages bien distincts dans le plan factoriel entre décrue et tarissement montre l'existence d'une relation claire entre débit et minéralisation. L'effet de l'état hydraulique sur les paramètres chimiques est très important et rend difficile la mise en évidence d'autres influences (par exemple, les variations climatiques saisonnières, l'activité anthropique, etc.). En effet, les plans factoriels n'ont pas mis en évidence d'autres variations non aléatoires de la réponse chimique des sources, ce qui montre que l'effet de l'hydraulique sur les variations chimiques est largement prédominant. A ce stade, les variations de la composition chimique liées à d'autres agents ne peuvent donc pas être détectées.

Pour tenter de mettre en évidence les effets d'autres agents, il faut analyser les résidus de la relation entre réponse chimique et débit, et pour cela, il faut soustraire de la réponse chimique observée la partie "expliquée" par la relation entre chimie et débit.

Dans ce but, les hypothèses suivantes doivent être admises : la variation observée de la réponse chimique est fonction :

- du régime hydraulique de la source;
- d'autres agents (climat, activités humaines, etc.);
- des erreurs (aléatoires) de mesures.

Relation concentration - débit

L'existence d'une relation non aléatoire entre minéralisation et débit a été démontrée ci-dessus; il convient maintenant de définir l'allure de cette relation.

Admettons que la concentration des éléments chimiques à la source est influencée par trois processus: la dissolution, la dilution et le transport convectif. Par hypothèse simplificatrice, il est admis que ces processus sont instantanés et homogènes dans l'ensemble du système. L'efficacité de ces processus est fonction de la vitesse et du volume d'eau qui transite dans le système.

La concentration instantanée à la source est égale à :

$$C_{(t)} = \frac{m/s}{v/s} \quad (1)$$

m = masse transportée ; v = volume d'eau.

$$C_{(t)} = \frac{M_{(t)}}{Q_{(t)}} \quad (2)$$

$M_{(t)}$ = masse instantanée transportée (débit massique);
 $Q_{(t)}$ = débit à la source (débit volumique).

La masse $M_{(t)}$ est fonction du débit. A un débit $Q_{(t)}$ élevé correspond une vitesse élevée de l'eau dans le système et un volume important de roche en contact avec l'eau. Par conséquent, la quantité de roche dissoute est plus importante et donc le transport de masse vers l'exutoire également. La relation entre la masse transportée par unité de temps et le débit, trouvée empiriquement à partir des mesures expérimentales, est de la forme suivante :

$$M_{(t)} = A * Q_{(t)}^\beta \quad (3)$$

A = masse transportée pour un débit unitaire (concentration);

Selon la valeur prise par β on peut envisager trois cas différents :

- $\beta < 1$ - l'augmentation du débit est plus importante que celle de la masse transportée;
- $\beta = 1$ - l'augmentation du débit augmente linéairement avec celle de la masse transportée;
- $\beta > 1$ - l'augmentation du débit est moins importante que celle de la masse transportée;
- Des valeurs de β négatives (diminution de la masse transportée alors que le débit augmente) n'ont jamais été observées à partir de nos mesures.

En introduisant la relation (3) dans la (2) on obtient :

$$C_{(t)} = \frac{A * Q_{(t)}^\beta}{Q_{(t)}} = \frac{A}{Q_{(t)}^{(1-\beta)}}$$

et en remplaçant $\Rightarrow \alpha = (1 - \beta)$

$$C_{(t)} = \frac{A}{Q_{(t)}^\alpha} = A * e^{-\alpha * \ln(Q_{(t)})} \quad (4)$$

La concentration est une fonction exponentielle du logarithme du débit.

$$C_{(t)}^{II} = A_{(t)}^{II} * e^{-\alpha * Ln(Q_{(t)})} \quad (7)$$

Cette courbe a alors une amplitude très voisine de celle de la courbe mesurée (figure 4). Moyennant d'admettre les hypothèses inhérentes à cette méthode, ces simulations indiquent que les variations du TAC sont fonction principalement du débit mais aussi, dans une moindre mesure, des saisons, donc des variations climatiques.

Il subsiste de petites différences entre les deux courbes, principalement pendant les crues. Elle sont dues au paramètre α qui est considéré comme constant dans la simulation, mais qui en réalité varie légèrement d'une crue à l'autre, principalement en fonction de l'état hydraulique du système précédant la récession.

Pour tester la validité de la méthode, il convient de tester la ressemblance entre la série simulée et la série observée, en mettant en évidence les fréquences caractéristiques ou les périodicités des séries. L'analyse spectrale des séries temporelles permet de tester la similitude entre deux séries. Cette méthode permet de décomposer la variance totale d'une chronique en fonction de ses fréquences (BOX & JENKINS 1970, MANGIN 1984, GRASSO & JEANNIN 1994).

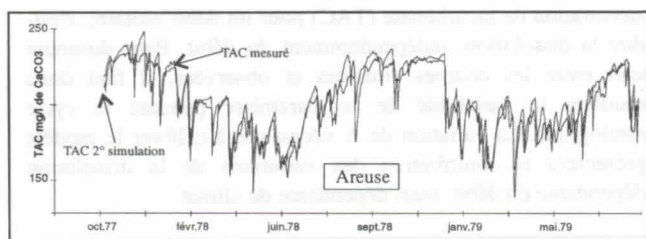

Figure 4 : Chroniques TAC mesuré, TAC simulé en fonction du débit et des variations saisonnières. Les résidus sont aléatoires.

Les spectres des séries mesurées et simulées (Fig. 5) présentent trois pics distincts qui correspondent aux mêmes fréquences caractéristiques pour les trois chroniques ($f1=0.0028$, $f2=0.00714$, $f3=0.0229$). Ces fréquences correspondent à des périodicités de 350 jours (cycle hydrologique annuel), 140 jours (cycle saisonnier) et 44 jours (intervalle moyen entre les crues les plus importantes). L'amplitude des pics de la deuxième simulation (série $C_{(Q,A,t)}^{II}$) est très proche de celle des données observées.

La présence des même pics de fréquence dans la série mesurée et dans les deux séries simulées représente un indice clair de la relation fonctionnelle prédominante entre la réponse chimique et l'état hydraulique du système. L'amélioration de l'ajustement entre la courbe observée et la courbe simulée lors de la deuxième simulation atteste de l'effet des variations climatiques saisonnières sur les variations du TAC dans les eaux de la source. Cet effet apparaît cependant nettement subordonné au premier.

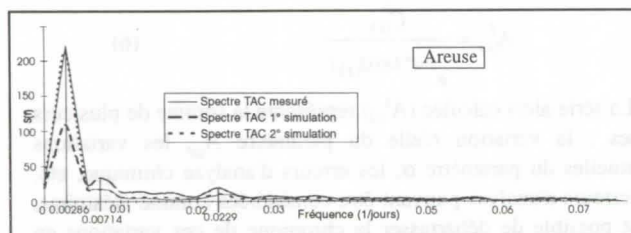

Figure 5 : La présence des mêmes périodicités dans le spectre du TAC observé et simulé confirme la relation fonctionnelle entre la réponse chimique et l'état hydraulique du système.

Conclusions générales

Le même type d'analyse a été appliqué à trois autres sources du Jura et des Préalpes suisses. Malgré des contextes hydrogéologiques et climatiques bien différents, les résultats généraux obtenus sont restés pratiquement les mêmes. Il ressort donc de cette étude que :

- Le débit joue un rôle très important sur la réponse chimique des sources karstiques. Ceci indique clairement que l'analyse du comportement chimique d'une source karstique sans prendre en considération son comportement hydraulique n'a pas de sens. Pour tester l'influence - généralement faible - d'autres facteurs que le débit sur la réponse chimique des systèmes karstiques, en particulier du climat, la méthode présentée ici consiste à modéliser l'influence du débit sur la réponse chimique, puis à soustraire cette influence de la réponse observée et à analyser la réponse résiduelle.
- La méthode présentée ici a été appliquée au TAC en vue de tester l'hypothèse d'une influence des variations de la pression de CO_2 dans les sols - dépendant du climat - sur la minéralisation des sources. Les résultats confirment cette influence, qui est cependant nettement subordonnée à celle de l'état hydraulique.
- La méthode présentée peut être utilisée pour tester d'autres hypothèses; il faut cependant relever que les résidus analysés après retranchement de l'effet du débit sont faibles, entachés de variations aléatoires et dépendent des simplifications admises dans le modèle utilisé. Les effets recherchés sont alors du même ordre de grandeur que les incertitudes inhérentes aux mesures et à la méthode d'analyse.
- La méthode proposée ici est en principe utilisable pour détecter les variations à long terme de la réponse chimique des sources karstiques liées aux variations climatiques. Cependant par rapport aux variations annuelles du climat, les variations climatiques à moyen terme (5 à 10 ans) sont très faibles et de ce fait probablement pas détectables. Sur les cinq à sept années de chroniques disponibles aux 4 sources étudiées, aucune tendance significative n'a pu être dégagée. Seules des chroniques nettement plus longues (30 ou 50 ans) pourraient fournir d'éventuels résultats interprétables.

Bibliographie

- BOX, G. P. & G. M. JENKINS 1970. Time series analysis, forecasting and control. Ed. Holden-Day, San Francisco, 553 pp.
- DAVIS, J. C. 1986. Statistics and data analysis in Geology (second edition). John Wiley & Sons, inc, New York 646, pp.
- GRASSO, D. A. & P.-Y. JEANNIN 1994. Etude critique des méthodes d'analyse de la réponse globale des systèmes karstiques: Application au site de Bure (JU, Suisse). *Bull d'Hydrogéologie 13-1994, Neuchâtel*: 87-113.
- KIRALY, L. & I. MÜLLER 1979. Hétérogénéité de la perméabilité et de l'alimentation dans le karst : effet sur la variation du chimisme des sources karstiques. *Bull. Centre d'Hydrogéologie Univ. Neuchâtel*, 3-1979: 237-282.
- MANGIN, A. 1981. Utilisation des analyses corrélatoire et spectrale dans l'approche des systèmes hydrologiques. *C.R. Acad. Sci. 293, Paris*: 401 - 404
- SCHOELLER, H.-J. 1980. Influence du climat, de la température sur la teneur en HCO_3 et H_2CO_3 des eaux souterraines. *J. of Hydrology 46*: 365-376.

Geochemical and geomathematical control of the karstic waters composition of the pan de Guajaibón and surroundings, Sierra Del Rosario, Pinar Del Río, Cuba

by Jesús M. Pajón-Morejón*, Argelio V. de la Cruz**,
Julio J. Valdés**, Alberto E. García* & Carlos M. Cruz*

* Instituto de Geofísica y Astronomía. Ministerio de Ciencia, Tecnología y Medio Ambiente

** Instituto de Cibernética, Matemática y Física. Ministerio de Ciencia, Tecnología y Medio Ambiente

Abstract

Cluster and Factorial analysis methods were applied to the chemical-physical data in the winter and summer geochemical periods 1-2/1984 and 9/1984, with the purpose to characterize the geochemical and chemical-physical behavior in the Pan de Guajaibón and surrounding waters, thus as the study of the relation between typology defined by geomathematical methods and geological and hidrogeological criterion.

The original matrix was conformed with the original variables; T, pH, SPC (25°C), CO₂ (mg/l) and ionic contents (as mg/l) of Ca²⁺, Mg²⁺, Na⁺+K⁺, HCO₃⁻, SO₄²⁻ and Cl⁻. Was studied the seasonal variation of some index and ionic contents in representatives points of each group of waters, during the period 1/1984 and 2/1986.

From the correlation analysis the signification and coherence between the original chemical-physical variables is analyzed. The characterization and punctual analysis, for the dynamic of dissolution-precipitation in the Pan de Guajaibón and Sierra Chiquita karstic massifs, considering the general tendency of the saturation index and CO₂ contents, suggest the occurrence of complex mechanisms of water-rock interaction, due to the frequent and intense mixing-waters effects in such massifs.

Resumen

Con el objetivo de caracterizar el comportamiento geoquímico y químico-físico de las aguas del Pan de Guajaibón y sus inmediaciones, así como estudiar la relación entre la tipología de las aguas definida por los métodos geomatemáticos y la definida según criterios geológicos e hidrogeológicos, se aplicaron métodos de clasificación numérica y análisis factorial a los datos químico-físicos correspondientes a la campañas geoquímicas 1-2/1984 y 9/1984, las cuales caracterizan los períodos de invierno y verano del referido año. La matriz original se conformó con las variables originales: T, pH, SPC (25°C), CO₂ (mg/l) y los contenidos iónicos (expresados como mg/l) de Ca²⁺, Mg²⁺, Na⁺+K⁺, HCO₃⁻, SO₄²⁻ y Cl⁻.

Se estudió la variación estacional de algunos índices y contenidos iónicos, en puntos representativos de cada grupo de aguas, durante al periodo comprendido entre el 1/1984 y el 2/1986. Se analizó la significación y coherencia de las asociaciones entre las variables químico-físicas originales, a partir del análisis de la correlación.

La caracterización y análisis puntual de la dinámica de disolución-precipitación en los macizos kársticos Pan de Guajaibón y Sierra Chiquita, teniendo en cuenta las tendencias generales de los índices de saturación y contenidos de CO₂, sugieren la ocurrencia de complejos mecanismos de interacción agua-roca, dado los frecuentes e intensos efectos de mezclas de aguas que ocurren en tales macizos.

1. Introduction

The present paper contains a brief compress of the geochemical and geomathematical results, obtained in the Pan de Guajaibón massif, in the Western Karst of Cuba. These results are included in the scope of International Program for Genesis and Evolution of Karst (PIGEK), which took place during 1984-1992, in order to study the dynamic of the Contemporary Karstic Processes in a representative Tropical Karst of Cuba, as well as the formulation of water-rock interaction models and the resultant morphological effects (PULINA et al., 1984).

2. Characteristics of the karstic area

The Pan de Guajaibón is a karstic massif (699 m a.s.l., A = 13 Km²) located in the most northwestward part of Sierra del Rosario mountain of the Guaniguanico Cordillera, in the province of Pinar del Río. There are two geological formations: The Pan de Guajaibón formation (albian-cenomanian) and Chiquita formation (campanian-maastrichtian).

The geological, geomorphological, hidrogeological and climatological characteristics of the studied area can be see in details in (PULINA et al., 1984) and (RODRIGUEZ et al., 1985).

3. Results and discussion

Geochemical and Geomathematical Characterization of the Karstic Waters:

The examined matrix was conformed with the original physico-chemical variables, analyzed "in situ", according the analytical techniques described by (MARKOWICZ & PULINA, 1979): T, pH, SPC (25°C), CO₂ (mg/l) and ionic contents (in mg/l) of Ca²⁺, Mg²⁺, Na⁺+K⁺, HCO₃⁻, SO₄²⁻ and Cl⁻. A Data Base was created with the information of six hydrochemical field-work campaigns in dry and wet periods. The Computer Programs used were AGMAR (FAGUNDO et al., 1986), CLUSTER and ANFACT (VALDES et al., 1981)(DE LA CRUZ & VALDES, 1985).

With the purpose to study the relation between the karstic waters typology defined by geomathematical methods and geological-hydrogeological criterion, as well as to make deep the internal structure of the phenomenons, Cluster and Factorial Analysis were applied to the physico-chemical data.

The figure 1 show the dendrogram of the numerical classification by the Ward method, using the dissimilarity measure (square Euclidean distance) for 35 individuals and 10 variables of the campaign 9/1984. From the combined analysis and interpretation between campaigns, we can deduce the presence of five groups of waters:

Group 1: Non-karstic surface waters (low mineralization and insaturate values of RSC, RSD and RSY).

Group 2: Waters of the aeration zone of Pan de Guajaibón massif (oversaturate values of RSC and RSD; insaturate values of RSY; low CO₂ contents).

Group 3: Waters of the aeration and discharge zone of Sierra Chiquita massif (oversaturate values of RSC and RSD; high values of CO₂ respect to the group 2).

Group 4: Waters of the discharge zone of Pan de Guajaibón massif (mixing-water effect).

Group 5: Spring-surface karstic waters in the zone Pan de Guajaibón-Sierra Chiquita (oversaturate values of RSC and RSD; high values of CO₂).

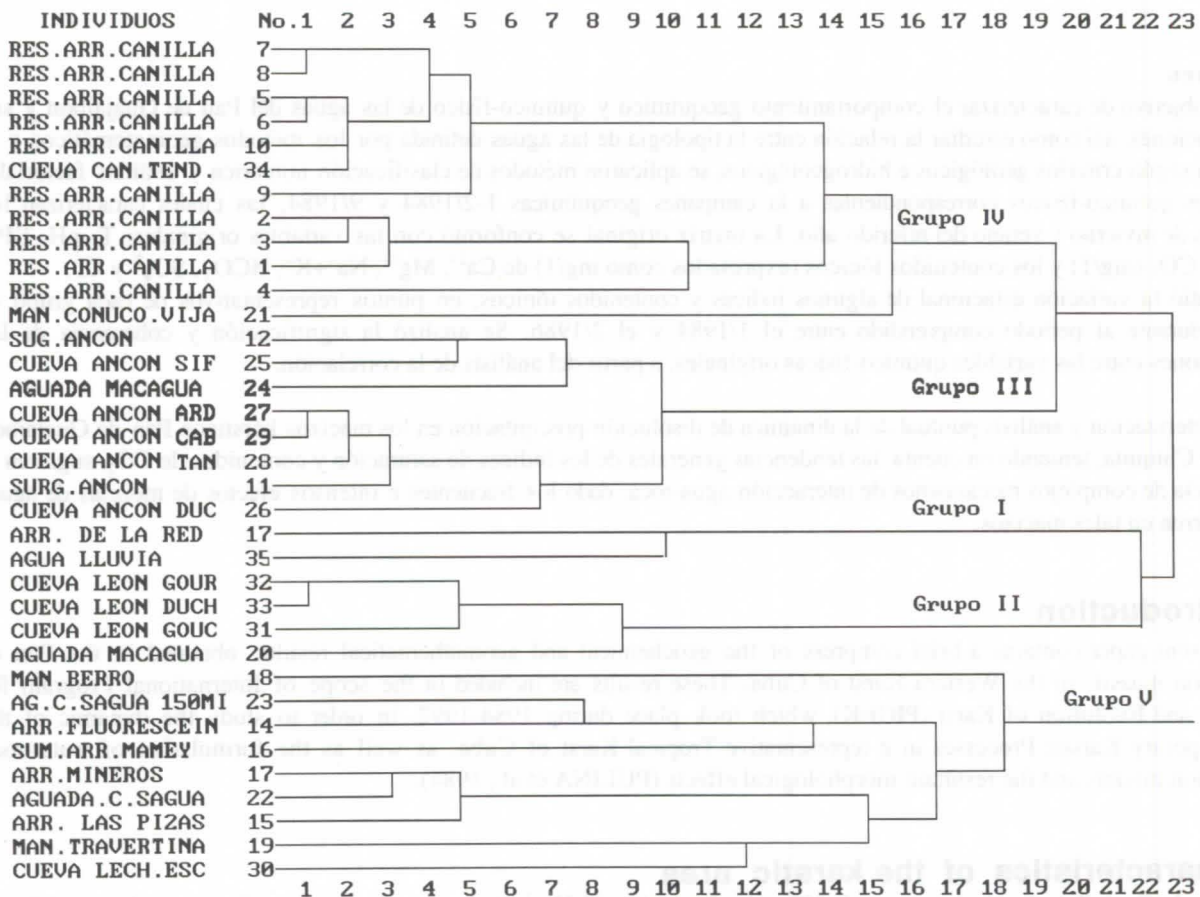

Figure 1.- Dendrogram with the hierarchical classification by the Ward method, for 35 individuals and 10 variables (campaign 9/1984).

To study the influence of the different geodynamic factors on the physico-chemical properties of the waters (BAKALOWICZ, 1979), was applied the Factorial Analysis Mode R, with varimax rotation, according the extraction of three factors to apportion around 76% of the total variance in the original variable.

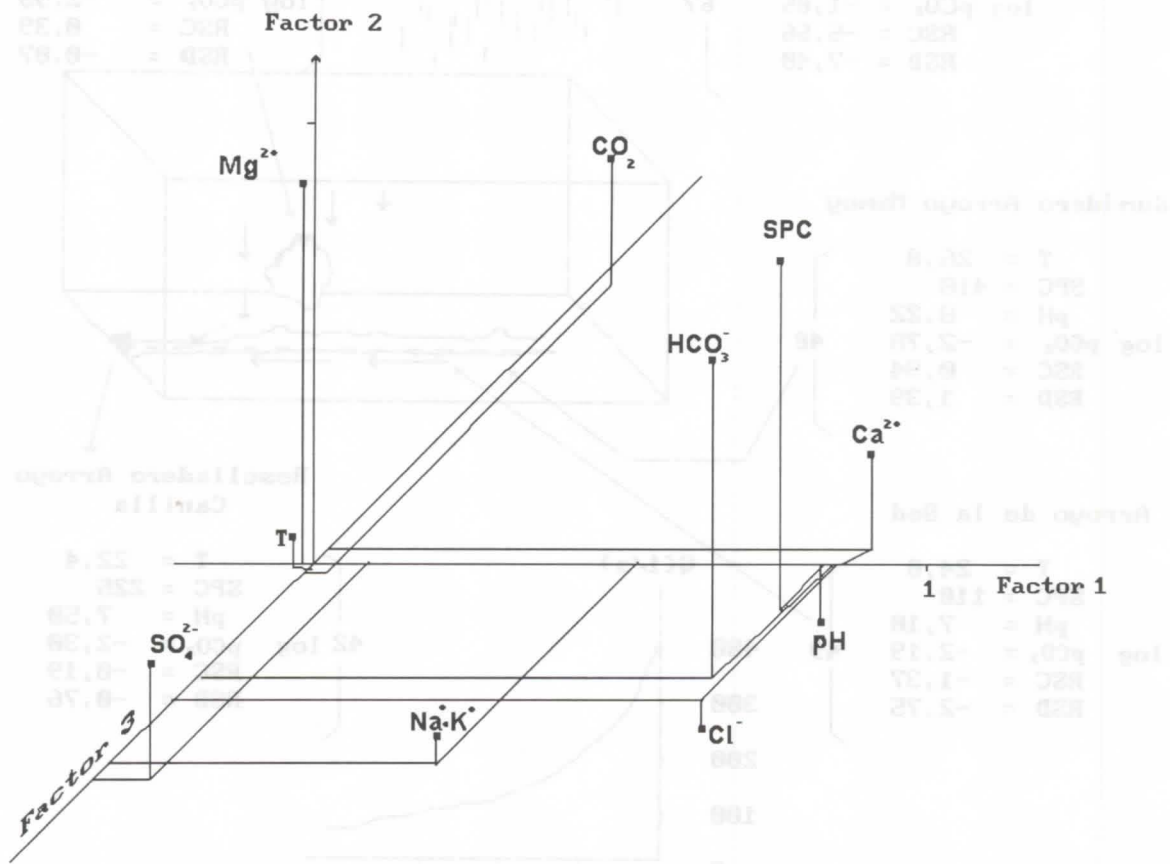

Figure 2.- Factorial Analysis. Distribution of the original variables, according the rotate factors (campaign 9/84).

In the figure 2 are plotted three rotated factors, suitable to the summer campaign 9/84. From the ensemble analysis, is possible arrive to the following conclusions: associate to the first factor appear the variables SPC, pH, Ca²⁺, HCO₃⁻ and Cl⁻ (it is related with the limestone rock, with strong control in the winter period). With an strong positive contribution to the second factor, the Mg²⁺, SPC, HCO₃⁻ and less the CO₂ (strong control of the limestone-dolomitizate rocks in the summer period on the variables Mg²⁺, HCO₃⁻, SPC and CO₂), which is according with the results of (JACOBSON & LANGMUIR, 1972). The SO₄²⁻ and Na⁺+K⁺ are associate to the third factor and the T to the fourth factor. An special study has been development, to obtain an adequate interpretation to the factors three and four (influence of biogenetical and degradative processes of organic matter in soils-humic/fulvic acids and CO₂ production).

The figure 3 show the dynamic of dissolution for the Pan de Guajaibón massif, in a punctual-time point of the water-rock interaction process, with a general increase of the saturation index and mixing-water effect. The correlation matrix between the original variables show a good coherence concerning the main variables of the CO₂-H₂O-CaCO₃ system. The chemical denudation calculated for both catchment area of Pan de Guajaibón-Sierra Chiquita massif, during the hydrological year 1984 are (PULINA et al., 1984): Ancon system (112 m³/km².year) and Canilla system (40 m³ /km².year) These results are in concordance with the results of the experimental simulation study with carbonate blocks of the studied area (PAJON & VALDES, 1991). A general discussion is located in this paper.

Acknowledgments

We would like to express our gratitude to the colleague Lic. Ismael Hernández for very helpful discussions and the composition of this paper.

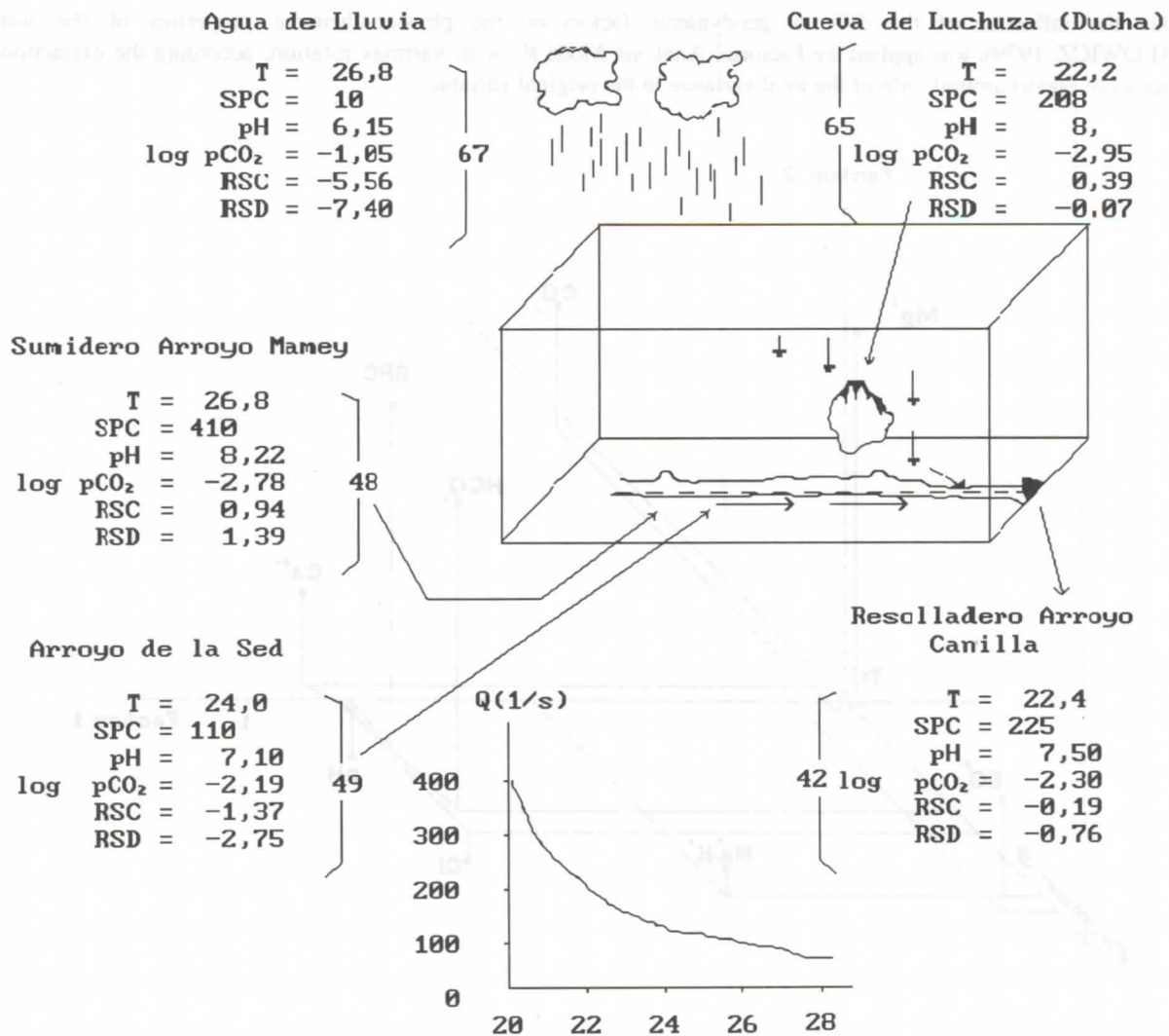

Figure 3.- Dynamic of Dissolution in the Pan de Guajaibón massif (campaign 9/84).

References

- DE LA CRUZ A. & VALDES J.J. 1985. Estudio de las aguas kársticas del Pan de Guajaibón y sus inmediaciones mediante métodos matemáticos de análisis exploratorio de datos. Rev. Vol. Hid. 68, Año XXII, 1985, pp. 25-34.
- FAGUNDO J.R., VALDES J.J., CARDOSO M.E., DE LA CRUZ A. 1986. Algoritmo para el cálculo de parámetros e índices químico-físicos y geoquímicos en aguas naturales altamente mineralizadas. Rev. Ciencias Químicas, 17, 1-2 pp.
- JACOBSON R.L. & LANGMUIR D. 1972. An accurate method of calculating saturation levels of groundwater with respect to calcite and dolomite. Trans. Cave Res. Group. G.B., Vol 14, No. 2, 104-108 pp.
- MARKOWICZ M. & PULINA M. 1979. Ilosciowa polmikroanaliza chemiczna wod wobszarach krasu weglanowego, Katowice, Poland, 67.
- PAJON J.M. & VALDES J.J. 1991. Simulacion química de la disolución de rocas carbonatadas del macizo kárstico de Pan de Guajaibón, Sierra del Rosario, Cuba. Rev. LAPIAZ, Monografía III, Valencia, Dic. 1991, 25-37 pp.
- PULINA M., FAGUNDO J.R., VALDES J.R., RODRIGUEZ J., KOZIK A., LESZKIEWICZ J., GLOWACKI P., PAJON J.M., DE LA CRUZ A., GARCIA A. 1984. The dynamic of the contemporary karstic processes in the tropical area of Cuba. Preliminary report of the field investigations performed by the Expedition Guajaibón'84 in the winter season 1984. Univ. Slaski, Sosnowiec, 40 pp.
- RODRIGUEZ J.E., CUTIE F., CRUZ C., FRANCO E., FAGUNDO J.R. 1989. Hidrología cársica del macizo Pan de Guajaibón. Sierra del Rosario. Año hidrológico Nov. 1984-Oct. 1985. De. Academia. La Habana, 1989, 61 pp.
- VALDES J.J., FAGUNDO J.R., PAJON J.M. 1981. Aplicación de métodos numéricos al estudio hidrogeoquímico de la cuenca del río Cuyaguatije. Rev. Ing. Hid. Vol. II, No. 3, 275-286 pp.

L'équation (4) peut être rendue linéaire par une simple opération algébrique :

$$\ln(C_{(t)}) = \ln(A) - \alpha * \ln(Q_{(t)})$$

Les paramètres A et α peuvent être déterminés au moyen d'un graphique $\ln(C_{(t)}) - \ln(Q_{(t)})$. $\ln(A)$ est la valeur du logarithme naturel de la concentration pour un débit unitaire, et α est la pente de la droite de régression.

On peut calculer α avec la formule suivante :

$$\alpha = \frac{\ln(C_1) - \ln(C_2)}{\ln(Q_2) - \ln(Q_1)}$$

Le coefficient α représente globalement l'action de eau dans le système en fonction du débit (processus de dissolution et de dilution simultanément).

Le coefficient α est ≤ 1 . Plus α est proche de 1, plus l'effet de dilution est important. Une augmentation importante du débit provoque une forte diminution de la concentration.

Plus α s'éloigne de 1, plus l'effet de dilution est faible. Une augmentation du débit a alors comme conséquence une faible diminution de la concentration.

Pour $\alpha=0$ la concentration est constante, donc indépendante du débit (mais la masse transportée par unité de temps varie en fonction du débit).

Pour $\alpha < 0$ une augmentation du débit entraîne une augmentation de la concentration.

En général, les observations expérimentales ont montré que les valeurs de A et α sont différentes selon que l'on considère la montée de la crue ou sa récession.

Simulation mathématique d'une chronique de TAC

Le TAC est un paramètre sensible aux variations climatiques puisqu'il dépend fortement de la production de CO_2 dans les sols. Celle-ci est fonction principalement des conditions climatiques, c'est-à-dire de la température et de l'humidité du sol à chaque instant. Elle est aussi fonction de la production de matière organique et de la disponibilité d'oxygène dissous ou combiné. Des variations climatiques (variation de la température et de la teneur en humidité) doivent donc entraîner des variations dans la production du CO_2 dans les sols, par conséquent d'acide carbonique dans les eaux souterraines qui influence la valeur du TAC (SCHOELLER 1980). La production de CO_2 dépend en particulier des saisons, mais aussi probablement des variations à plus long terme.

Pour essayer de mettre en évidence l'effet des variations climatiques sur la chimie des eaux, la chronique du TAC a été simulée en fonction du débit en utilisant le modèle décrit au paragraphe précédent.

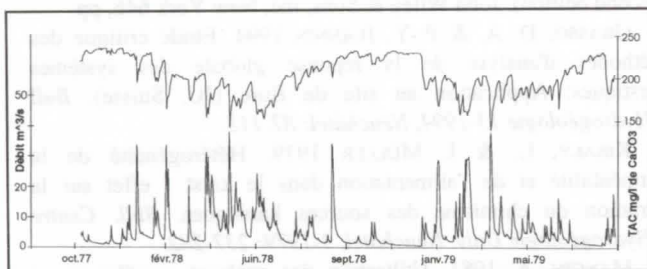

Figure 2 : Les variations du TAC sont opposées à celles du débit. Le TAC augmente lorsque le débit diminue et inversement.

Le TAC présente des variations opposées à celles du débit (Fig. 2); c'est-à-dire qu'il a tendance à augmenter lorsque le débit

diminue et inversement. Les crues sont marquées par des abaissements brusques de la valeur du TAC. Pour simuler la variation du TAC en utilisant la relation (4), des valeurs moyennes des paramètres A et α ont été calculées sur toute la série (chroniques des années 78-79). Les résultats de la simulation sont données à la figure 3 qui montre que l'essentiel des variations du TAC pendant les deux cycles hydrologiques peut être considéré comme une fonction du débit.

Analyse des résidus : effets du climat

Pour analyser les écarts entre la courbe simulée et la courbe observée, des moyennes mobiles du TAC calculées sur 30 jours ont été utilisées (figure 3). Elles montrent que l'amplitude des variations du TAC simulé est moins importante que celle du TAC mesuré.

La différence entre les deux courbes décrit la partie du TAC qui ne peut pas être expliquée par les variations du débit. Il apparaît que cette partie présente un cycle saisonnier.

Dans la simulation, A est considéré comme constant. En réalité, ce paramètre varie pendant le cycle hydrologique (variabilité saisonnière). Il représente, dans ce cas, la concentration de bicarbonate (TAC) pour un débit unitaire, c'est-à-dire la dissolution, indépendamment du débit. Pour diminuer l'écart entre les courbes simulées et observées, il faut donc considérer la variabilité de ce paramètre pendant le cycle hydrologique. La variation de A nécessaire à calibrer le modèle représentera la contribution des variations de la dissolution indépendante du débit, mais dépendante du climat.

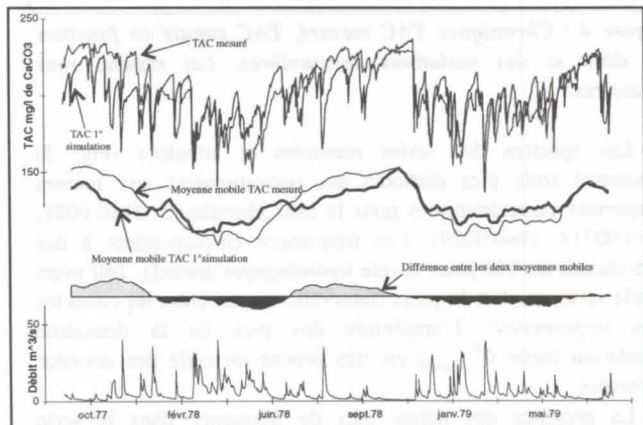

Figure 3 : Chroniques TAC observé, simulé $f(Q)$ et résiduel; Les résidus présentent des variations saisonnières.

Pour estimer les variations du paramètre A au cours de l'année, il convient d'introduire la concentration du TAC mesuré ($C_{(t)}$) dans l'équation 4 et de calculer l'erreur sur le A considéré constant dans la première simulation (le paramètre α est supposé constant).

$$A_{(t)}^I = \frac{C_{(t)}}{e^{-\alpha * \ln(Q_{(t)})}} \quad (6)$$

La série ainsi calculée ($A_{(t)}^I$) représente la somme de plusieurs causes : la variation réelle du paramètre $A_{(t)}$, les variations éventuelles du paramètre α , les erreurs d'analyse chimique, etc. Les erreurs d'analyse pouvant être considérées comme aléatoires, il est possible de débarrasser la chronique de ces variations en calculant la moyenne mobile de ($A_{(t)}^I$). On obtient alors la chronique $A_{(t)}^{II}$. En introduisant le paramètre $A_{(t)}^{II}$ (moyenne mobile de $A_{(t)}^I$) dans l'équation (4) on obtient la chronique du TAC en fonction de $A_{(t)}^{II}$ et de $Q_{(t)}$:

Géologie et géochimie des eaux dans le réseau du Grand Cor (Valais-Suisse)

par Jérôme Perrin,

Institut de Minéralogie, Université de Lausanne, Dorigny, CH-1015 Lausanne

Résumé

Le réseau du Grand Cor est une cavité de haute altitude (2700 m.) s'ouvrant sous la Dent de Morcles (Valais-Suisse) et développant quelque 4500 mètres de conduits dans le flanc inverse de la nappe de Morcles (domaine Helvétique). Sa profondeur de 600 mètres autorise quelques observations géologiques intéressantes; parallèlement une étude de la géochimie des eaux a été entreprise, elle a permis d'appréhender l'évolution du chimisme dans la zone vadose de ce karst haut alpin.

Abstract

The Grand Cor system is situated below the Dent de Morcles in the Valais Alps (Switzerland) at an altitude of 2700 meters; the 4500 meters of conduits developed in the inverted limb of the Morcles nappe (Helvetic domain).

The 600 meters depth of this system allows some interesting geological observations; also a study of the water geochemistry was made with the aim of better understanding the chemical evolution in the vadose zone of this high alpine karst.

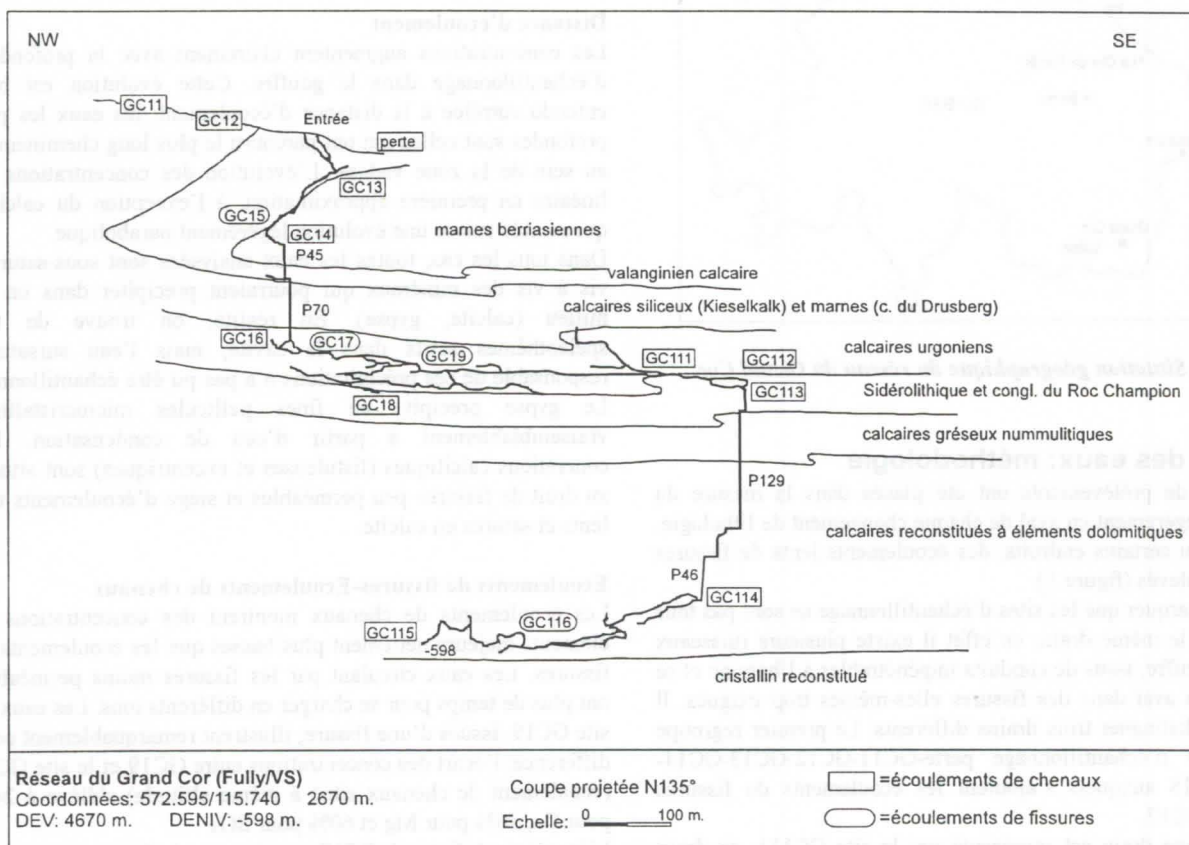

Figure 1: Coupe géologique du Réseau du Grand Cor présentant la situation des points d'échantillonnage.

1. Préambule

La majorité des études concernant l'hydrochimie du karst se cantonnent aux sources karstiques, elles fournissent des informations sur le comportement hydrodynamique et sur les particularités géochimiques des aquifères karstiques. Les études hydrochimiques portant sur la zone vadose du karst restent étonnamment peu nombreuses alors que l'on sait que le chimisme des eaux karstiques s'acquiert principalement dans cette zone "superficielle" (MAIRE, 1990). L'étude présentée dans cet article a pour objectif d'apporter une modeste contribution à cette problématique méconnue.

Le choix du terrain s'est porté sur le réseau du Grand Cor pour deux raisons: ce gouffre est situé en milieu haut alpin, l'absence de couverture pédologique permet de s'affranchir de l'influence du sol sur la chimie des eaux souterraines (ATTEIA, 1992); les atteintes anthropiques sur le milieu sont minimisées. D'autre part, ce réseau traverse des roches au chimisme fort différent (PERRIN, 1996) susceptibles d'influencer le chimisme des eaux (figure 1).

L'évolution temporelle du chimisme a été délibérément laissée de côté devant l'impossibilité d'effectuer des prélèvements serrés.

2. Situation géographique et géologique

Le réseau du Grand Cor est situé dans les Alpes valaisannes (Suisse occidentale), au-dessus de la petite ville de Martigny. L'unité tectonique dans laquelle il se développe est l'Helvétique, et plus précisément la nappe de Morcles. Cette nappe est peut-être la plus "célèbre" des Alpes, elle a fait l'objet de nombreuses publications (voir par exemple BADOUX, 1972; MASSON *et al.*, 1980; RAMSAY, 1981). Elle présente un flanc normal et un flanc inverse, la série sédimentaire qui la constitue va de l'Aalénien au Tertiaire. Le réseau du Grand Cor se développe uniquement dans le flanc inverse, sa profondeur (-598 mètres) permet de traverser l'intégralité de la série sédimentaire Crétacé-Tertiaire; le fond du gouffre arrive à proximité du plan de chevauchement de la nappe (figure 1). La série sédimentaire traversée montre une grande variabilité de roches: calcaires, calcaires siliceux, marnes, conglomérats à éléments calcaires, dolomitiques, marneux, cristallins.

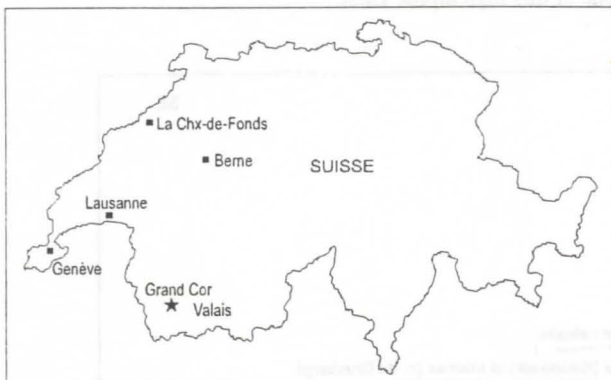

Figure 2: Situation géographique du réseau du Grand Cor.

Chimie des eaux: méthodologie

Les sites de prélèvements ont été placés dans la mesure du possible légèrement en aval de chaque changement de lithologie, de plus, en certains endroits, des écoulements lents de fissures ont été prélevés (figure 1).

Il faut remarquer que les sites d'échantillonnage ne sont pas tous situés sur le même drain; en effet il existe plusieurs ruisseaux dans le gouffre, issus de conduits impénétrables à l'homme et se perdant en aval dans des fissures elles-mêmes trop exigües. Il s'agit de distinguer trois drains différents: Le premier regroupe les points d'échantillonnage perte-GC11-GC12-GC13-GC14-GC16-GC18 auxquels s'ajoutent les écoulements de fissures GC15 et GC17.

Le deuxième drain est représenté par le site GC111, ce drain avait été considéré comme un écoulement lent de fissure et c'est pour cela qu'il a été prélevé, cependant les analyses chimiques ont montré qu'il s'agit en fait d'un écoulement très rapide.

Le troisième drain est constitué par les points d'échantillonnage GC112-GC113-GC114, alors que le site GC115 est soit le prolongement aval du premier drain soit un drain encore différent. Un seul écoulement de fissure a été observé dans la zone profonde, c'est le site GC116.

Les eaux du réseau résurgent à la source de la Sarvaz au niveau de la vallée du Rhône. Le chimisme de cette source est très particulier mais ne sera pas abordé ici (voir PERRIN & TACCHINI, 1997).

Les eaux prélevées ont été conditionnées dans des bouteilles neuves en polyéthylène de 250 ml rincées préalablement deux fois avec l'eau à analyser. Deux bouteilles ont été remplies pour

chaque échantillon, une bouteille étant acidifiée par 1ml d' HNO_3 65% suprapur afin de garder les cations en solutions. Toutes les eaux ont été filtrées à l'aide d'un filtre Nalgène 40 μ permettant l'élimination des matières en suspension, à l'exception des colloïdes. Les bouteilles ont été stockées moins de 24 heures après le prélèvement dans un endroit frais (4°C).

Les éléments majeurs ont été analysés par chromatographie ionique (Dionex 300) et les éléments traces ont été dosés par ICP-MS couplé AES (TJA-Poems).

4. Les éléments majeurs

Les eaux analysées sont de type bicarbonaté-calcaïque, cependant quelques échantillons montrent une tendance à être sulfatés, c'est le cas par exemple pour le point de prélèvement GC19.

Les trois éléments montrant le comportement le plus significatif sont discutés dans la suite, il s'agit du calcium, du magnésium et des sulfates.

Différents facteurs sont à la source des variations chimiques illustrées à la figure 3, nous allons les passer en revue:

Distance d'écoulement

Les concentrations augmentent clairement avec la profondeur d'échantillonnage dans le gouffre. Cette évolution est bien entendu corrélée à la distance d'écoulement: les eaux les plus profondes sont celles qui ont parcouru le plus long cheminement au sein de la zone vadose. L'évolution des concentrations est linéaire en première approximation, à l'exception du calcium qui semble suivre une évolution légèrement parabolique.

Dans tous les cas, toutes les eaux analysées sont sous-saturées vis à vis des minéraux qui pourraient précipiter dans un tel milieu (calcite, gypse). En réalité, on trouve de tels spéléothèmes actifs dans la cavité, mais l'eau sursaturée responsable de ces précipitations n'a pas pu être échantillonnée. Le gypse précipite en fines pellicules microcristallines vraisemblablement à partir d'eau de condensation. Les concrétions calcitiques (fistuleuses et excentriques) sont situées au droit de fissures peu perméables et siège d'écoulements très lents et saturés en calcite.

Écoulements de fissures-Écoulements de chenaux

Les écoulements de chenaux montrent des concentrations en éléments majeurs nettement plus basses que les écoulements de fissures. Les eaux circulant par les fissures moins perméables ont plus de temps pour se charger en différents ions. Les eaux du site GC19, issues d'une fissure, illustrent remarquablement cette différence: l'écart des concentrations entre GC19 et le site GC18 (écoulement de chenaux situé à même altitude) s'élève à 24% pour Ca, 56% pour Mg et 60% pour SO_4 .

L'écoulement fissural GC17 montre aussi des concentrations sensiblement plus élevées que les écoulements de chenaux mais en proportions moindres. L'écoulement de fissure GC116, situé dans la zone profonde du gouffre, n'a malheureusement pas pu être échantillonné, mais la conductivité mesurée était de 406 $\mu\text{S}/\text{cm}$ alors que l'écoulement de chenaux le plus proche montre une conductivité de 113 $\mu\text{S}/\text{cm}$.

L'écoulement GC15 sort d'une fissure centimétrique, mais son chimisme est en tout point semblable aux écoulements de chenaux: certaines fissures peuvent donc être le siège d'écoulements forts rapides...

Variations saisonnières liées aux changements hydrodynamiques

Ces variations sont illustrées par les deux séries d'échantillonnage: l'une effectuée en août lors de la fonte des

neiges, l'autre en novembre alors que le massif est déjà sous l'emprise du gel. Les prélèvements lors de la crue d'été sont proportionnellement moins concentrés, l'eau de fonte dilue fortement les solutions. Il est probable que les vitesses d'écoulement plus rapides en crue favorisent également la dilution (dissolution moins efficace).

En étiage, les concentrations en calcium dans les écoulements de chenaux se rapprochent très nettement des concentrations dans les écoulements de fissures.

Les sulfates montrent un écart plus important que le magnésium, cette différence doit tenir aux modalités de mise en solution de ces deux ions.

Anomalies liées au chimisme de la roche environnante

Les site d'échantillonnage GC19 (écoulement de fissure) montre des concentrations très élevées en Mg et SO₄ (respectivement 3.5 et 25 mg/l). De telles concentrations doivent provenir de la circulation de cette eau dans les grès sidérolithique à pyrite, la pyrite constituant un apport de SO₄ non négligeable.

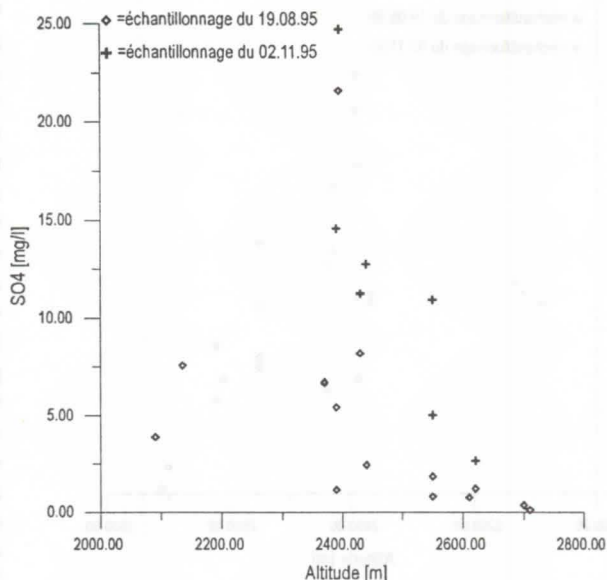
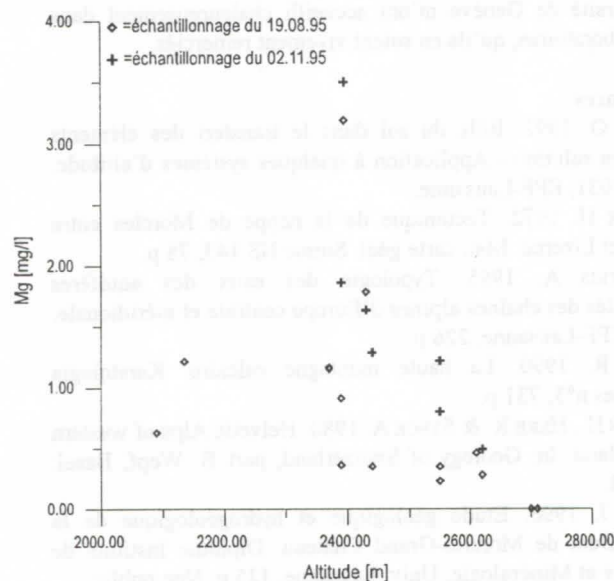
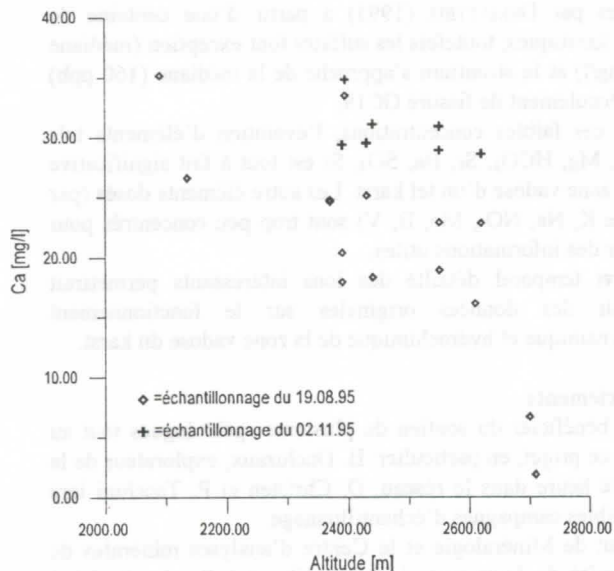

Figure 3: Evolution de la concentration en éléments majeurs (Ca, Mg, SO₄) en fonction de l'altitude et des conditions hydrodynamiques.



5. Les éléments traces

La figure 4 représente l'évolution concentration-altitude pour les trois éléments traces les plus significatifs, à savoir Si, Sr et Ba. Les facteurs influençant le chimisme des eaux développés dans le chapitre précédent restent valable pour les éléments traces. Quelques points méritent toutefois d'être soulignés pour chacun de ces éléments:

La silice

La silice augmente linéairement avec la profondeur dans le gouffre. Les eaux d'étiage sont légèrement plus concentrées que les eaux de crue. Les écoulements de fissures se marquent par une légère anomalie positive. La silice est présente dans toutes les roches traversées généralement sous forme de quartz authigène ou détritique, les teneurs varient sensiblement d'une formation à l'autre.

Le strontium

Les concentrations en strontium augmentent avec la profondeur selon une courbe vaguement parabolique. L'écoulement de fissure GC19 montre une anomalie positive très nette; les échantillons d'étiage sont faiblement plus concentrés. Le comportement de cet élément se rapproche significativement du magnésium.

Le baryum

Le baryum voit ses concentrations augmenter linéairement avec la profondeur, les échantillons d'étiage sont faiblement plus concentrés. Par contre, les écoulements de fissures ne sont que très légèrement enrichis.

Le baryum et le strontium sont présent en traces dans la calcite, il est d'autre part possible que le strontium provienne en partie de la strontianite (cependant aucune occurrence de ce minéral n'a pu être observée sur le terrain).

Ces deux éléments peuvent dans tous les cas être considérés comme de bons traceurs des aquifères carbonatés.

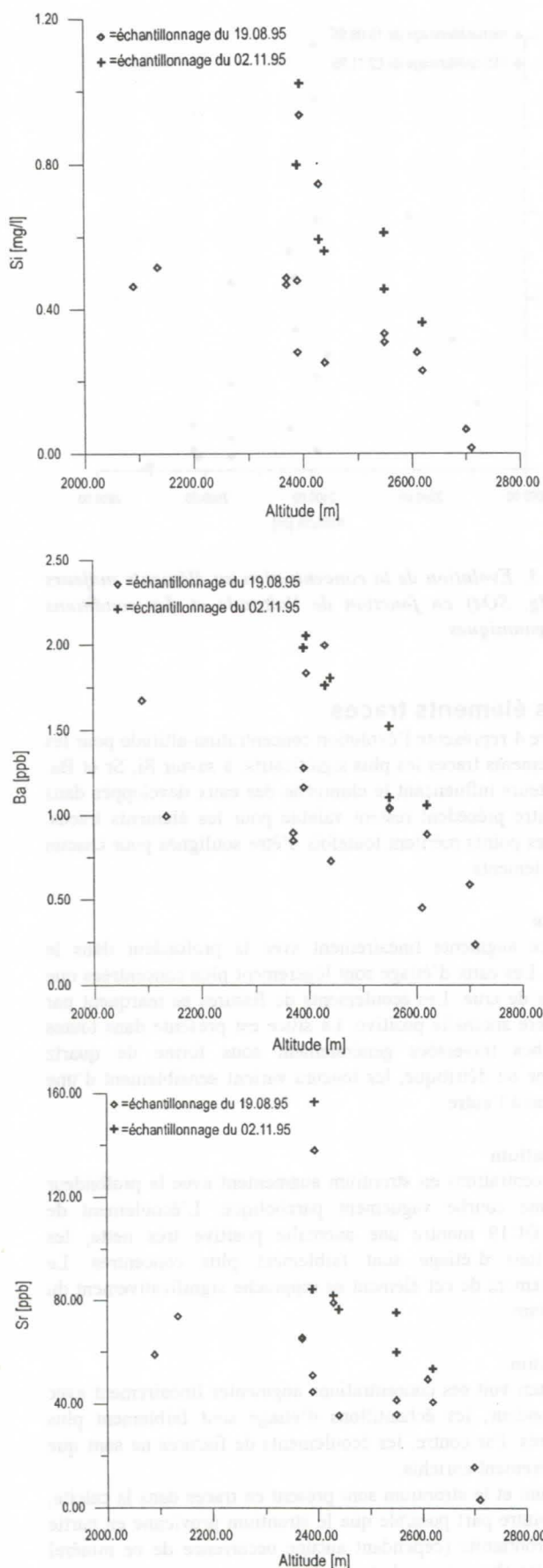

Figure 4: Evolution de la concentration en éléments traces (Si, Ba, Sr) en fonction de l'altitude et des conditions hydrodynamiques.

6. Conclusions-Perspectives

Les différents ions discutés plus haut voient leur concentration augmenter avec la distance de ruissellement dans la zone vadose, cependant aucun ion ne peut être considéré comme un traceur sûr de la formation géologique traversée. En effet, les ions présentant une évolution (Ca, Mg, Sr, Ba, Si, HCO₃ et SO₄) se retrouvent, sous forme minérale, dans l'ensemble des roches traversées. La seule exception est l'écoulement de fissure GC19: cette eau a été en contact avec les grès sidérolithiques à pyrite et montre de fortes concentrations en SO₄, Mg, Sr, (Si).

On pouvait s'attendre à un marquage des formations telles que le Berriasien marneux par Na-K-Al-Si, l'Hauterivien siliceux par Si, les niveaux dolomitiques par Mg, or il n'en est rien. Cette absence de marquage est liée au type d'écoulement de cet aquifère karstique: les écoulements sont trop rapides et empêchent toute dissolution de minéraux dont la cinétique de mise en solution est lente; seuls les écoulements vraiment lents (tel que GC19) échappent à cette règle et montrent des anomalies en certains ions.

La majorité des éléments dosés dans les eaux du réseau du Grand Cor sont bien en dessous des concentrations médianes calculées par DEMATTEIS (1995) à partir d'une centaine de sources karstiques; toutefois les sulfates font exception (médiane = 9,7 mg/l) et le strontium s'approche de la médiane (160 ppb) pour l'écoulement de fissure GC19.

Malgré ces faibles concentrations, l'évolution d'éléments tels que Ca, Mg, HCO₃, Sr, Ba, SO₄, Si est tout à fait significative dans la zone vadose d'un tel karst. Les autres éléments dosés (par exemple K, Na, NO₃, Mo, B, V) sont trop peu concentrés pour apporter des informations utiles.

Un suivi temporel détaillé des ions intéressants permettrait d'obtenir des données originales sur le fonctionnement hydrodynamique et hydrochimique de la zone vadose du karst.

Remerciements

J'ai pu bénéficier du soutien de plusieurs spéléologues tout au long de ce projet, en particulier: B. Ducluzaux, explorateur de la première heure dans le réseau, D. Christen et P. Tacchini lors des pénibles campagnes d'échantillonnage.

L'Institut de Minéralogie et le Centre d'analyses minérales de l'Université de Lausanne ainsi que l'Institut Forel rattaché à l'Université de Genève m'ont accueilli chaleureusement dans leurs laboratoires, qu'ils en soient vivement remerciés.

Références

- ATTEIA O. 1992. Rôle du sol dans le transfert des éléments traces en solution - Application à quelques systèmes d'altitude. Thèse 1031, EPF-Lausanne.
- BADOUX H. 1972. Tectonique de la nappe de Morcles entre Rhône et Lizerne. Mat. carte géol. Suisse NS 143, 78 p.
- DEMATTEIS A. 1995. Typologie des eaux des aquifères carbonatés des chaînes alpines d'Europe centrale et méridionale. Thèse EPF-Lausanne, 226 p.
- MAIRE R. 1990. La haute montagne calcaire. Karstologia mémoires n°3, 731 p.
- MASSON H., HERB R. & STECK A. 1980. Helvetic Alps of western Switzerland. In: Geology of Switzerland, part B. Wepf, Basel: 109-153.
- PERRIN J. 1996. Etude géologique et hydrogéologique de la région Dent de Morcles-Grand Château. Diplôme Instituts de Géologie et Minéralogie, Univ. Lausanne, 125 p. Non publié.
- PERRIN J. & TACCHINI P. 1997. Le système karstique grotte du Poteu-source de la Sarvaz (Valais-Suisse). Ces actes.
- RAMSAY J. G. 1981. Tectonics of the Helvetic nappes. In: Thrust and Nappe Tectonics. The Geological Society of London.

Hydrogeochemical characterization of Tito Bustillo cave (northern Spain)

S. Sanchez-Moral ¹, J. C. Cañaveras ¹, E. Sanz-Rubio ¹, M. Hoyos ¹ and V. Soler ²

¹ Dept. Geología. Museo Nacional Ciencias Naturales. José Gutiérrez Abascal, 2. E-28006 Madrid (Spain)

² Instituto de Productos Naturales y Agrobiología de Canarias. C.S.I.C. E-38206 La Laguna, Tenerife. Spain.

Abstract

The geochemical characteristics of karstic water in Tito Bustillo Cave are the result of two main types of recharge: authigenic recharge via percolating and infiltrating water through conduits and fractures, and allogenic-authigenic recharge via San Miguel river that sinks (Gorgocera ponor) into the karst system. The chemical composition of San Miguel river reflects that its drainage basin is located on siliceous (shales and sandstones) and calcareous lithologies; likewise, the influence of tides is also present. The chemistry of infiltrational waters, specially P_{CO_2} , show a direct relation with climatic conditions (rainfall regime) and soil development. Hydrogeochemical data, in conjunction with others data, such as microclimatic conditions, are necessary to assess the deterioration induced by man action in show caves.

Resumen

Las características geoquímicas de las aguas kársticas de la Cueva de Tito Bustillo reflejan dos tipos de recarga: recarga autigénica por la percolación-infiltración via conductos y fracturas, y recarga alogénica-autigénica por medio del rio San Miguel que se sume en el sistema kárstico en el paraje del sumidero de la Gorgocera. La composición química del rio San Miguel muestra que su cuenca de drenaje atraviesa litologías silíceas (pizarras y areniscas) y calcáreas; asimismo tambien denota la influencia del régimen de mareas. La composición química de las aguas infiltracionales, especialmente en los valores de P_{CO_2} , está directamente relacionada con el régimen de lluvias y con el desarrollo de cobertera vegetal. Los datos hidrogeoquímicos, junto con otros datos como las codiciones microclimáticas de la cueva, son necesarias para una apropiada valoración del deterioro antrópico en cuevas turísticas.

I. Introduction

Multidisciplinary studies, including hydrochemistry and climatic characterization, are necessary for the conservation of valuable geological, biological and cultural (archaeological) elements in caves and karst. This paper focuses on the study of the geochemical characterization on karstic waters in Tito Bustillo Cave (northern Spain) which hosts one of the most important paleolithic rock-paintings of western Europe. This is part of a multidisciplinary study focused on making the suitable conservation of rock paintings compatible with Tito Bustillo Cave tourism industry.

Tito Bustillo Cave is located in Ribadesella (Asturias, northern Spain), in the western riverside of Sella Ria (Cantabrian Sea). This cave belongs to the Ardines karst which is a relict polygenic karst system initially developed during the Lower Pliocene on a carboniferous calcareous relief (Ardines Massif). This massif is formed mainly by a thick sucession of gray to beige-coloured limestones that shows a homogeneous mineralogical composition (93-100% calcite; 0-7% clays and quartz). The San Miguel River sink

into the Ardines karst (Gorgocera ponor) and intermitently flow (aproximately 600m) through Tito Bustillo Cave's passages, towards its mouth in the Sella Ria (fig. 1). The Gorgocera ponor is located 30 m high above sea level.

II. Surface Water

Two main types of recharge can be distinguished in the Ardines karst system: disperse authigenic recharge via percolating and infiltrating water through dolines and karren fields from rainfall; and authigenic-allogenic recharge via San Miguel river drainage basin. The San Miguel drainage basin is composed of several smaller sub-basins (for instance, the Sardedo and San Juan sub-basins which are mainly composed of shales and sandstones) and show an elongated shape with a total surface of 9.7 km². The slopes are pronounced, favouring high runoff and low infiltration rates in the upper drainage basin. The drainage density is low, specially in the zones with calcareous lithology. The chemical composition of waters in Tito Bustillo Cave, the lower zone of the drainage basin, is very influenced by the fact that the San Miguel River pass through zones with different lithology, as is expressed below.

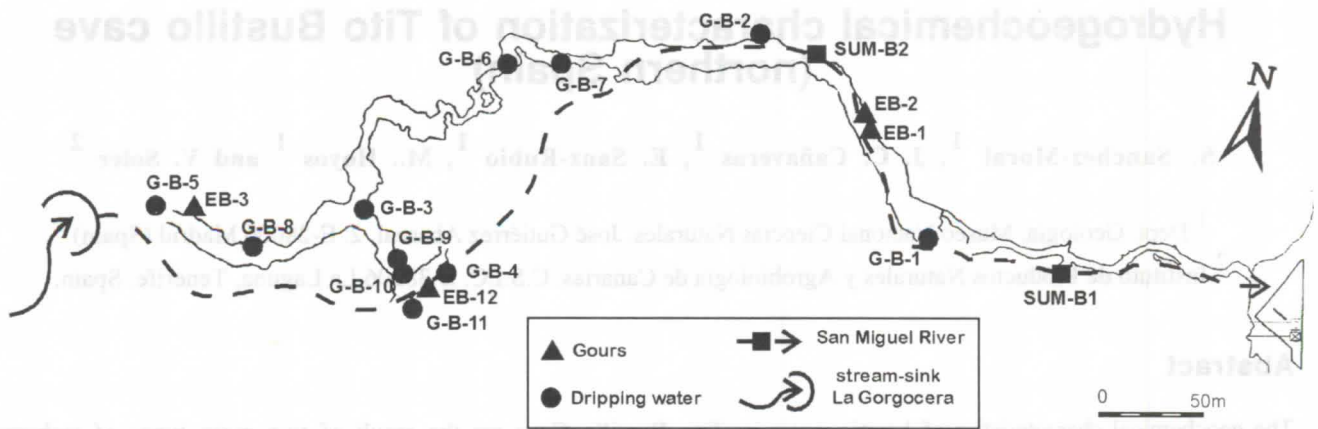

Figure 1. Location of sampling points in Tito Bustillo Cave

The composition of surface waters related to San Miguel river was achieved by chemical analyses (major elements) of a total of 18 samples corresponding to stream-waters and underground springs (Martínez, 1990 and this work). The chemical composition of these waters reflect the lithological characteristics of the zone where they flow.

A) - Samples from springs in calcareous zones are of $\text{HCO}_3\text{-Ca}$ type. These water are close to calcite saturation and are similar to those of Gorgocera ponor, but with higher Ca and HCO_3 contents.

B) - Samples from the upper drainage basin (San Miguel River, San Juan River and San Juan Creek; siliceous lithology) are also of the $\text{HCO}_3\text{-Ca}$ type, but with higher SO_4 and Cl contents and low values of total dissolved solids.

The chemical composition of waters from San Miguel river before their entrance in the interior of Tito Bustillo Cave reflects an effect of mixing between authigenic underground discharge and allogenic recharge from the upper drainage basin. In order to test this phenomenon a theoretical mixing was performed using average compositions of waters of type A and B. The result is shown in figure 2; the proportions used in the theoretical mixing are 60% and 40% respectively.

III. Groundwater

A total of 29 samples of water corresponding to gours, dripping-points and San Miguel river during three different sampling campaigns (July 1995; Sepetember-October 1995; May 1996) were collected (see fig. 1 for sampling locations and table I for dates of sampling). The last sampling campaign was carried out after a high rainfall period (70 l/m^2) and the infiltration rates were perceptibly higher than in the previous sampling compaigns. The temperature,

electrical conductivity, pH and $\text{CO}_2 = \text{HCO}_3^-$ contents were measured at the time the sample was taken. These samples were stored at a constant temperature ($12\text{-}14^\circ\text{C}$) and taken to the laboratory where Ca, Mg, Na, K, SO_4 , Cl, NO_3 were analyzed two days later. The saturation states and Pco_2 values of waters were calculated from the temperature and the chemical composition of the water sampling. The speciation calculation necessary for determining the mineral saturation indices (table I) was made using the PHRQPITZ computer code (Plummer and others, 1988).

- San Miguel river (in the interior of the cave).

The samples SUM-B1 reflect a strong marine influence due to its proximity to the Sella Ria, with high values of Cl, Na and total dissolved solids, higher than the rest of the samples collected in the interior of the cave. Concerning saturation states, these waters are very near to equilibrium respect to the main carbonatic mineral phases.

The two samples termed SUM-B2 are waters of $\text{HCO}_3\text{-Cl-Ca}$ type; in low tide periods (september 1995) a decrease in the Cl-content can be observed. Both samples was undersaturated with respect to calcite and aragonite, which are the most common carbonatic mineral phases in the host rock and in the speleothems of the cave.

- Gours.

These waters are of $\text{HCO}_3\text{-Ca}$ type, with low concentration in total dissolved species. The samples with the lowest Pco_2 values are located in zones where air renovation rates are higher (in the proximity of gorgocera ponor, where an entry of the cave is located) and subsequent outgassing effect is also higher.

- Dripping waters.

These waters are of $\text{HCO}_3\text{-Ca}$ type, with SO_4 and Mg contents ranging from 1 to 5%; Cl and Na contents

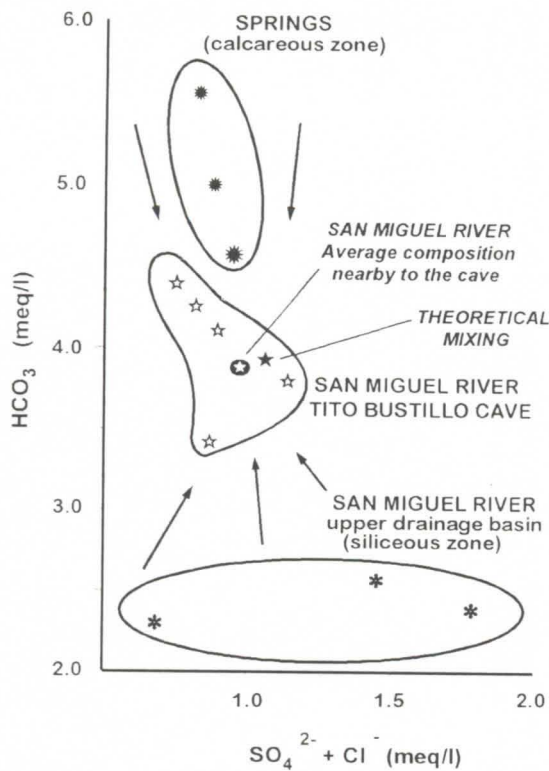

Figure 2. HCO_3^- vs $(SO_4^{2-} + Cl^-)$ plot diagram showing chemical composition of San Miguel River ranging from 1 to 12% and from 4 to 11% respectively

. These relatively high values in Cl and Na contents in the infiltration waters reflect the input of sea salts near the coast by means of aerosol effect (Drever, 1982). Samples corresponding to zones with active speleothem formation (calcite and aragonite in mineralogy; samples GB-3; GB-4 and GB-1) are oversaturated in main carbonatic mineral phases. Samples GB-2, GB-5 y GB-8 are undersaturated in these minerals showing low water-rock interaction rates reflecting low residence times and high infiltration rates of the waters. Samples GB-9, GB-10 and GB-11, show an anomalous chemical composition respect to the rest of the sampled waters with a concentration of SO_4 , ranging from 13 to 31%. This sulphate-rich character coincides with the existence of gypsum crystal growth affecting (and deteriorating) the pigments of paleolithic rock-paintings.

Concerning P_{CO_2} values, these samples show a great variability. The higher P_{CO_2} values correspond to samples collected in May 1996, that is, after a high rainfall period as previously mentioned. The CO_2 produced in the soil by biological activity in the uppermost zone of the Ardines Massif is dissolved by rainwater which filters into it, this being the vehicle for transporting the CO_2 to the interior of the karst; when the infiltration waters reaches the cave, partial outgassing of this is produced, CO_2 being released into the cave atmosphere. The lowest P_{CO_2} values correspond to summer season with a slight increase in autumn due to the begin of a high rainfall period.

IV. Conclusions

The chemical composition of the waters of San Miguel river before its sinking into Tito Bustillo cave reflect an effect of mixing between authigenic underground discharge and allogenic recharge from upper drainage basin. In the interior of the cave this chemical composition is affected by the composition of infiltrational waters and the effect of tides dynamic. This multiple influence in the karstic water must be considered in order to assess the deterioration processes induced by man actions (polution of karstic waters, mass-tourism, etc.). Infiltrational waters show a direct relation to rainfall regime and soil development in the surface of the Ardines karst system. In this way, the highest P_{CO_2} values correspond to spring seasons as a response of higher infiltration rates. Although most of these waters are of HCO_3-Ca type, we have detected $Ca-SO_4$ enriched dripping-waters affecting the conservation of rock paintings.

Table I. Saturation indices of main carbonate mineral phases and P_{CO_2} values of the analyzed waters (R: river; G: gour; D: dripping water)

Sample	Date	Type	Aragonite	Calcite	Dolomite	Gypsum	PCO_2
SUM-B 1	11/07/95	R	+0.09	+0.28	+0.74	-1.43	$10^{-2.69}$
SUM-B 1	29/09/95		-0.29	-0.09	-0.09	-1.53	$10^{-2.40}$
SUM-B 2	11/07/95	R	-0.32	-0.13	-0.92	-2.23	$10^{-2.17}$
SUM-B 2	29/09/95		-0.33	-0.13	-0.94	-2.12	$10^{-2.18}$
E-B 1	22/05/96	G	-0.14	+0.05	-1.08	-2.23	$10^{-2.39}$
E-B 2	29/09/95	G	-0.37	-0.18	-1.51	-2.38	$10^{-2.31}$
E-B 3	29/09/95	G	-0.04	+0.15	-0.85	-2.71	$10^{-2.86}$
E-B 12	22/05/96	G	-0.42	-0.23	-1.18	-2.73	$10^{-2.69}$
G-B 1	11/07/95	D	+0.20	+0.40	-0.48	-2.41	$10^{-2.91}$
G-B 1	30/09/95		+0.09	+0.28	-0.69	-2.41	$10^{-2.63}$
G-B 1	22/05/96		-0.20	0	-1.30	-2.35	$10^{-2.58}$
G-B 2	11/07/95	D	-0.46	-0.27	-1.53	-2.96	$10^{-2.91}$
G-B 2	22/05/96		-0.64	-0.44	-1.94	-2.86	$10^{-2.67}$
G-B 3	11/07/95	D	+0.79	+0.99	+1.06	-1.97	$10^{-3.19}$
G-B 3	29/09/95		+0.68	+0.88	+0.92	-1.95	$10^{-2.87}$
G-B 3	30/09/95		+0.52	+0.71	+0.59	-1.99	$10^{-2.73}$
G-B 3	1/10/95		+0.55	+0.74	+0.62	-1.97	$10^{-2.78}$
G-B 3	22/05/96		+0.11	+0.31	-0.26	-2.01	$10^{-2.38}$
G-B 4	11/07/95	D	+0.29	+0.49	-0.09	-2.20	$10^{-2.95}$
G-B 4	30/09/95		+0.19	+0.38	-0.34	-2.19	$10^{-2.88}$
G-B 4	22/05/96		+0.16	+0.36	-0.56	-2.11	$10^{-2.41}$
G-B 5	11/07/95	D	-0.35	-0.15	-1.27	-2.72	$10^{-3.18}$
G-B 6	30/09/95	D	-0.21	-0.02	-1.22	-3.97	$10^{-2.85}$
G-B 6	22/05/96		-0.47	-0.27	-1.79	-2.66	$10^{-2.59}$
G-B 7	30/09/95	D	-0.18	0	-1.03	-3.41	$10^{-3.03}$
G-B 8	1/10/95	D	-0.68	-0.49	-1.94	-2.89	$10^{-2.73}$
G-B 9	22/05/96	D	-0.48	-0.28	-1.37	-2.02	$10^{-2.84}$
G-B 10	22/05/96	D	-0.39	-0.20	-1.18	-1.93	$10^{-2.88}$
G-B 11	22/05/96	D	-0.40	-0.21	-1.02	-1.39	$10^{-2.93}$

References

Drever, J.L. 1982. The geochemistry of Natural Waters: 388 pp. Prentice-Hall, Englewood Cliffs, New Jersey

Hoyos, M. 1979. El karst en Asturias durante el Pleistoceno superior y Holoceno. Unpublished Ph Thesis. 413pp

Martínez, E. 1990. Prevención de inundaciones en la Cueva de Tito Bustillo. Informe para la Consejería de Cultura del Principado de Asturias. 118 pp.

Plummer, L.N.; Parkhurst, D.L.; Fleming, G.W. & Dunkle, S.A. 1988. PHRQPITZ, a computer program incorporating Pitzer's equations for calculation of geochemical reactions in brines. US Geol Surv Water Res Inv 88-4153: 310 pp.

Acknowledgements

This work has been supported by the Council for Education, Culture, Sports and Youth of the Principality of Asturias by means of a Scientific Cooperation Agreement with the C.S.I.C. The authors wish to express their gratitude to Prof. J. Fortea, (Univ. Oviedo) for his collaboration throughout the whole period of the investigation. Hydrogeochemical analyses and mineralogical determinations were conducted with the assistance of M.A. Vallejo, M.I. Ruiz and R. González (MNCN-CSIC).



Figure 1. HCO₃⁻ vs. SO₄²⁻ + Cl⁻ relationship showing sample composition of San Miguel River.

The relatively high value in Cl and SO₄ in the karstic waters reflect the input of sea salt from the coast by means of coastal effect (Lowe, 1981) samples corresponding to caves with active pedogenic formation (L-10, L-11 and L-12) is mineralogy, samples GB-1, GB-2, GB-3, GB-4, GB-5, GB-6, GB-7, GB-8, GB-9, GB-10, GB-11 and GB-12 are characterized as more calcareous mineral waters. Samples GB-2, GB-3, GB-4, GB-5, GB-6, GB-7, GB-8, GB-9, GB-10 and GB-11 show an enrichment in SO₄ ranging from 1.7 to 1.9. The sulphate-rich character coincides with the presence of gypsum, several growth efflorescing and demonstrating the presence of calcite and aragonite.

Concerning P_H values, these samples show a great variety. The P_H values correspond to samples collected in July 1992 that is after a light rainfall period in previous months. The CO₂ content in the soil is important activity in the upper part of the karstic zone is derived by rainwater which filters into the cave the water for transporting the CO₂ to the karstic zone, when the infiltration water reaches the karstic zone, this is produced CO₂ being released into the atmosphere. The P_H values correspond to samples taken with a slight decrease in rainfall, but the input of a light rainfall period.

Sample	Date	Type	Ca ²⁺ (meq/l)	Mg ²⁺ (meq/l)	SO ₄ ²⁻ + Cl ⁻ (meq/l)	HCO ₃ ⁻ (meq/l)
GB-1	11/07/92	R	-0.08	-0.08	-0.14	-1.43
GB-2	20/09/92		0.07	-0.08	-0.09	-1.83
GB-3	11/07/92	R	0.02	0.12	-0.05	-1.37
GB-4	25/07/92	R	0.07	0.11	-0.06	-1.37
GB-5	17/09/92	R	0.14	0.04	-1.08	-1.53
GB-6	20/09/92	D	-0.07	-0.18	-0.24	-1.88
GB-7	20/09/92	D	0.06	-0.15	-0.09	-1.71
GB-8	25/07/92	D	-0.03	-0.18	-0.21	-1.73
GB-9	11/07/92	D	0.06	-0.04	-0.88	-1.81
GB-10	20/09/92		0.08	-0.08	-0.08	-1.41
GB-11	25/07/92		0.03	-0.18	-0.25	-1.36
GB-12	11/07/92	D	0.06	-0.07	-0.27	-1.96
L-10	21/07/92	D	0.04	0.04	-1.84	-1.88
L-11	17/09/92	D	0.08	-0.08	-1.08	-1.97
L-12	20/09/92		-0.08	-0.08	-0.88	-1.84
L-13	20/09/92		-0.02	-0.11	-0.23	-1.99
L-14	11/07/92		0.05	-0.04	-0.83	-1.97
L-15	20/09/92		-0.11	-0.07	-0.38	-1.91
L-16	11/07/92	D	0.03	-0.04	-0.28	-1.91
L-17	20/09/92		-0.12	-0.08	-0.24	-1.91
L-18	21/07/92	D	-0.02	-0.12	-0.38	-1.71
L-19	20/09/92		0.01	0.02	-0.21	-1.93
L-20	20/09/92		0.07	-0.07	-1.18	-1.88
L-21	20/09/92		0.01	0	-0.18	-1.47
L-22	11/07/92	D	-0.08	-0.08	-1.04	-1.88
L-23	20/09/92	D	-0.08	-0.08	-1.04	-1.88
L-24	20/09/92	D	-0.08	-0.08	-1.04	-1.88
L-25	20/09/92	D	-0.08	-0.08	-1.04	-1.88
L-26	20/09/92	D	-0.08	-0.08	-1.04	-1.88
L-27	20/09/92	D	-0.08	-0.08	-1.04	-1.88
L-28	20/09/92	D	-0.08	-0.08	-1.04	-1.88
L-29	20/09/92	D	-0.08	-0.08	-1.04	-1.88
L-30	20/09/92	D	-0.08	-0.08	-1.04	-1.88

Karst aquifer genesis - Modelling approaches and controlling parameters -

Martin Sauter, Rudolf Liedl, Torsten Clemens, Dirk Hückinghaus

Applied Geology, University of Tübingen, Sigwartstrasse 10, 72076 Tübingen, Germany

Abstract

The quantification of regional groundwater flow and the transport of dissolved substances in a karst system generally poses problems in parameter identification as well as in the modelling of the above processes. On the other hand, available qualitative and quantitative geological information on the history of the development of karst aquifers, which can provide information on the distribution of karstified horizons within the modelled domain, are generally not considered. A model has been developed, capable of simulating the interactions between the different processes, i.e. flow, transport coupled with carbonate dissolution, taking into account the varying boundary conditions, e.g. changes in geological and geomorphological (base level) and climatic conditions (recharge depth, temperature). A sensitivity analysis of the duration of karstification to changes in climatic parameters and physico-chemical constants of carbonate dissolution shows that the equilibrium concentration of calcium and the initial diameter of the conduits are very dominant factors.

Zusammenfassung

Die Quantifizierung von Grundwasserströmung und Stofftransport in Karstsystemen ist gekennzeichnet durch Probleme in der Erkundung und durch einen Mangel an angepassten Modellwerkzeugen. Dagegen wird vielfach verfügbare geologische, geomorphologische, paläohydrologische Information über die Entstehung dieser Systeme nicht verwendet, obwohl sie Aufschluß über Parameterverteilung und Aquifergeometrie zur Verfügung stellen könnte. In diesem Artikel wird ein numerisches Modell vorgestellt das die Entstehung und zeitliche Entwicklung von Karstsystemen unter Berücksichtigung der komplexen Strömungs- und Karbonatlösungsprozesse für zeitlich variable Randbedingungen (Vorfluterniveau, Grundwasserneubildung, Temperatur) simuliert. Mittels Sensitivitätsanalyse konnte gezeigt werden, daß die Gleichgewichtskonzentration von Kalzium und der initiale Durchmesser der Karströhren zu den für die Verkarstungsdauer wichtigsten Größen gehören.

1. Introduction

The understanding of the genesis of karst aquifer systems has been the objective of research for some time. For a long period this field of research had been approached from a more descriptive point of view. With the understanding and quantification of the carbonate dissolution kinetics (PLUMMER AND WIGLEY, 1976; RAUCH AND WHITE, 1977; PLUMMER et al, 1978) it was possible to investigate the main factors involved in karst development (PALMER, 1981; 1991; DREYBRODT, 1990; 1996). The application of these principles however was up to now only applied to simple boundary conditions (JAMES AND KIRKPATRICK, 1980; GROVES & HOWARD, 1994; HOWARD & GROVES, 1995, DREYBRODT, 1996) e.g. near hydraulic structures.

The understanding of the karstification processes at a regional, i.e. catchment scale could be of most valuable importance for the quantification of the geometry of karst aquifers as well as their parameter distribution in space. This information would be most useful for the prognosis of flow and transport in karst systems. Generally, geological, geomorphological and paleohydrological information is available and could be used for the specification of boundary conditions in space and time.

In this paper, a new modelling approach is presented, integrating the chemical dissolution kinetics of carbonate rocks as well as the special hydraulic characteristics of karst systems, thereby allowing the simulation of the development of karst systems at a catchment scale. With this model, the sensitivity of the development of karst aquifers to a change in various parameters is demonstrated.

2. Modelling Approach and Processes

Figure 1 summarises the most important processes for karst aquifer genesis. Groundwater flow is represented by a dualistic flow system, i.e. a highly conductive, low storage (0.0001) conduit system and a much less permeable but high storage (0.02) fissured system. The conduit system is characterised by high flow velocities (up to several 100 m/h). Depending on the flow velocities, laminar or turbulent flow conditions can occur. Flow between the two systems is controlled by the difference in potential.

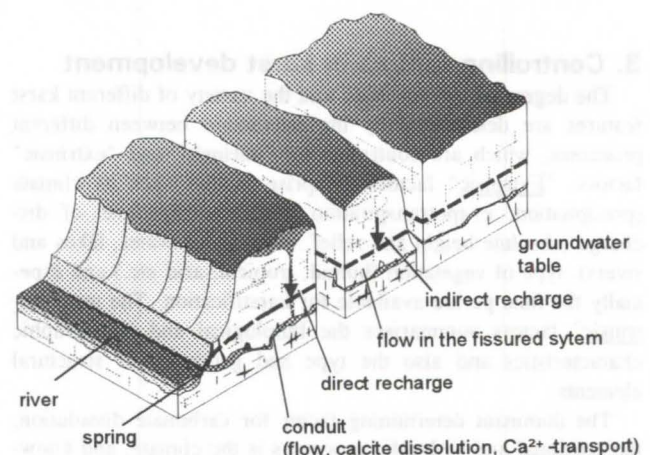

Figure 1: Flow system and processes

There are two different modes of infiltration of groundwater recharge: a) direct recharge, which reaches the phreatic zone within a few days via highly conductive vertical shafts and dolines, b) indirect recharge, arriving at the water table considerably delayed. It is important to distinguish between these two types of recharge components, because of their different quantities and degree of undersaturation with respect to calcite.

Dissolution of carbonate occurs along the conduits and consequently their diameters are enlarged with time. This increase in diameter leads to an increase in hydraulic conductivity of the conduit network and to an enhanced calcite dissolution, i.e. a positive feedback mechanism between flow and dissolution processes.

Further, it has to be taken into account that some of the parameters, important for the karstification process and consequently on the karstification period, such as rate constants, equilibrium constants, viscosity, also depend on temperature.

The above described processes were implemented in a numerical model (CAVE, Carbonate Aquifer Void Evolution). Flow in the fissured system is modelled using a continuum approach (BERKOWITZ, 1988) whereas flow in the conduit network is described by flow in a tube network, which follows Kirchhoff's rule, saying that the sum of inflows and outflows equal to zero at every node (HORLACHER & LÜDECKE, 1992). The exchange of water between the continuum and the tube network systems is controlled by their potential difference and an exchange coefficient, determined by the hydraulic conductivity of the fissured system and geometric factors.

Transport of Ca^{2+} -Ions is modelled using a one-dimensional advection equation, expanded by a source term, allowing for the increase in ionic concentrations along the flow path due to carbonate dissolution. Further source terms describe the input of calcium-ions from recharge.

The quantification of the carbonate dissolution is based on experimental results from BUHMANN & DREYBRODT (1985). According to the authors, different reaction rates could be determined, depending on the concentration in solution. Rapid dissolution prevails for concentrations far from (first order rate law) and slow dissolution close to (fourth order rate law) calcite equilibrium concentration.

Details of the model, its verification and sample runs are presented in CLEMENS et al. (1996), CLEMENS et al. (1997) and HÜCKINGHAUS et al. (1997).

3. Controlling factors in karst development

The degree of karstification and the variety of different karst features are determined by the interaction between different processes, which are controlled by "intrinsic" and "extrinsic" factors. "Extrinsic" factors comprise factors such as climate (precipitation, evapotranspiration, temperature), level of discharge (absolute height and relief, level of sea water, lakes and rivers), type of vegetation (humid, tropical, arid etc.) and especially the time period available for karstification. The term "intrinsic" factors summarises the lithological and petrographic characteristics and also the type and geometry of structural elements.

The dominant determining factor for carbonate dissolution, the erosional and hydraulic processes is the climate, and knowledge of its temporal variation is an important prerequisite for reliable predictions of the intensity of karstification and the spatial distribution of the karstified zones. Figure 2 (changed after FORD & WILLIAMS, 1989) shows the importance of the

influence of the climate on karstification and illustrates the different feed-back mechanisms inherent in such a complex system.

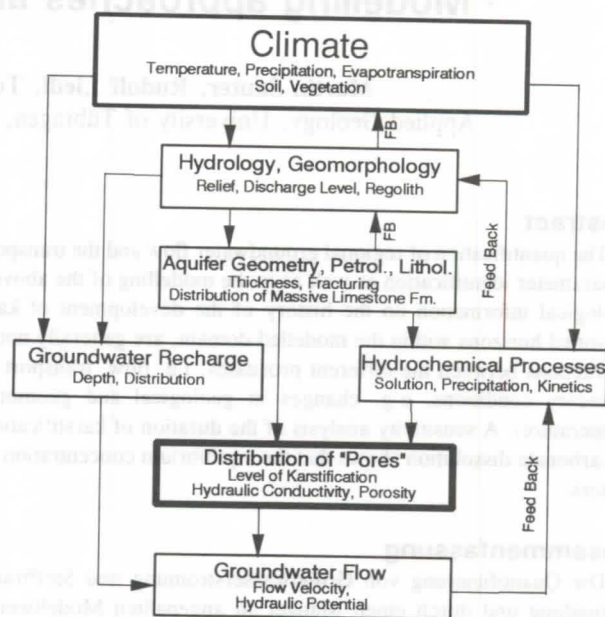

Figure 2: Influence of the climate on karst development and important feedback mechanisms (after FORD & WILLIAMS, 1989)

4. Sensitivity analysis for the duration of karstification

By varying the magnitude of the relevant process parameters, one at the time, the sensitivity of the duration of the karst development was examined. The model used was described by CLEMENS et al (1996). The flow model is rectangular and measures 1350 * 1250 m². There are no flow boundaries on 3 sides and a fixed head boundary on the fourth side, representing e.g. a river. The conduit system is discretised as a central series of tubes, connected to the fixed head boundary, with initial diameters of 0.4 mm. Groundwater recharge was 400 mm/a with 1% as direct recharge. The input concentration of the direct recharge was 0 mol/L. This data set forms the "standard" of Table 1 and is taken from laboratory experiments (e.g. BUHMANN AND DREYBRODT, 1985) and field investigations in S Germany. The parameters are varied within a range that is believed to occur in nature (Table 1). The karstification periods specified in the following represent the times when turbulent flow conditions prevail throughout the tube network. Here only the main results are summarised (Fig. 3).

In this analysis, the Ca^{2+} -equilibrium concentration and the initial tube diameter have been identified as the controlling factors for karstification. A reduction in the equilibrium concentration by 50% leads to an increase in the duration of karstification by 18646 years. Similarly a reduction in the initial diameter by 50% leads to a prolongation of karstification by more than 10000 years.

Table 1: Data set for sensitivity analysis

Parameter	Minimum	Standard	Maximum
Ca ²⁺ -Equilibrium Concentration (mmol/L)	1.0	2.0	3.0
initial tube diameter (mm)	0.2	0.4	1.0
Dissolution rate constant close to equilibrium (cm ¹⁰ mol ⁻³ s ⁻¹)	2.5*10 ¹²	1.2*10 ¹³	5.0*10 ¹³
Dissolution rate constant far from equilibrium (cm/s)	2.5*10 ⁻⁶	2.0*10 ⁻⁵	1.5*10 ⁻⁴
Groundwater recharge (mm)	160	400	1829
kinematic viscosity (m ² /s)	1.8*10 ⁻⁶	1.3*10 ⁻⁶	1.0*10 ⁻⁶
percentage of direct recharge (%)	0.5	1	2

The sensitivity of karstification with respect to the kinetic rate constants and groundwater recharge is considerably less. Within the range of parameters analysed, the spatial distribution of groundwater recharge between conduit and fissured system and the viscosity of the water play a negligible role for the duration of karstification.

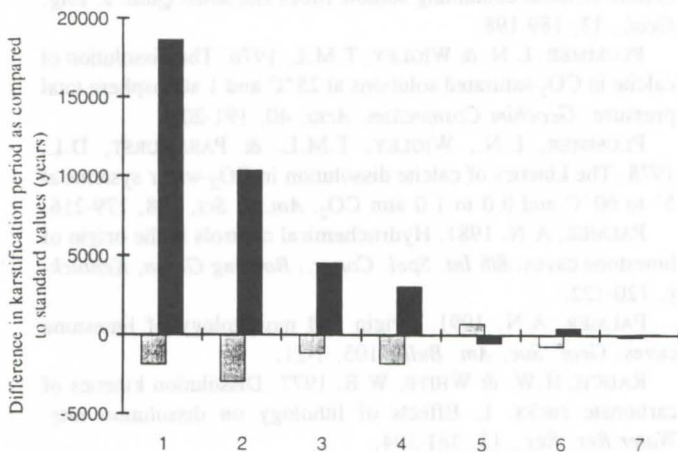

Figure 3: Results of sensitivity analysis for parameters: (1) Ca²⁺-equilibrium concentration, (2) initial tube diameter, (3) rate constant for concentrations close to equilibrium, (4) groundwater recharge, (5) rate constant for concentrations far from equilibrium, (6) kinematic viscosity, (7) distribution of groundwater recharge (grey: maximum, black: minimum value of respective parameter, cf. Table 1)

However, during the course of aquifer development, the percentages assumed for direct recharge might well change by an order of magnitude to 10% and more, leading to much reduced duration.

Further, the input concentrations of direct and indirect recharge (c_{dir} , c_{FK}) and the concentration threshold for the change between first order dissolution and fourth order dissolution, k_{sw} were varied as well. The results are summarised in Table 2. An increase in the input concentrations obviously leads to an extension of the karstification period whereas a reduction in the above threshold value k_{sw} (standard condition $k_{sw} = 0.9$) speeds up the increase in the tube diameter, because undersaturated water can penetrate further into the tubes due to the reduced dissolution rate under conditions of fourth order (slow) kinetics.

Table 2: Effect of a change in c_{dir} , c_{FK} and k_{sw} on karstification

Parameter	Value	Change in karstification period
Input concentration direct recharge, c_{dir}	1.4 mmol/L	+ 654 years
Input concentration indirect recharge, c_{FK}	1.88 mmol/L	+ 323 years
concentration threshold k_{sw} (fraction of equilibrium concentration)	0.6	- 2804 years

The parameters c_{dir} , c_{FK} , and k_{sw} , however, need further investigation in the field in order to determine their effect on the duration of the karstification.

5. The role of the climate

In the above sensitivity analysis, only a single parameter was varied at the time. However, climatic changes evoke a multitude of factors to vary, which are important for karstification, such as temperature, evapotranspiration and precipitation. A change in these meteorological parameters brings about changes in the type of vegetation and therefore also in the carbon dioxide production in the soil. Changes in the carbon dioxide concentration and precipitation in turn change the rate of erosional processes, which also affect discharge levels.

In Figure 4, the effect of a change in temperature on the duration of karstification is illustrated as an example how complex the system can be affected by a change in a single master variable. In sum: With all other variables constant, an increase in temperature by ten degrees reduces karstification time from approximately 50000 years to ca. 10000 years. With an increase in temperature the first order dissolution rate constant is increased thereby prolonging the duration of karstification, the viscosity of the water is decreased, leading to shorter durations and the equilibrium concentration of calcium is decreased, with a consequential increase in the duration of karstification. The dominant parameter, however, is the increased production rate of carbon dioxide, which overall decreases the time required for the development of a mature karst system (Table 3).

Table 3: Effect of an increase in temperature on variables, controlling duration of karstification

Parameter	Change in Parameter	Change in duration of karstification
Viscosity of water	-	-
Dissolution rate constant far from equilibrium	+	+
Partial pressure of carbon dioxide in the soil	+	-
Equilibrium concentration	-	+

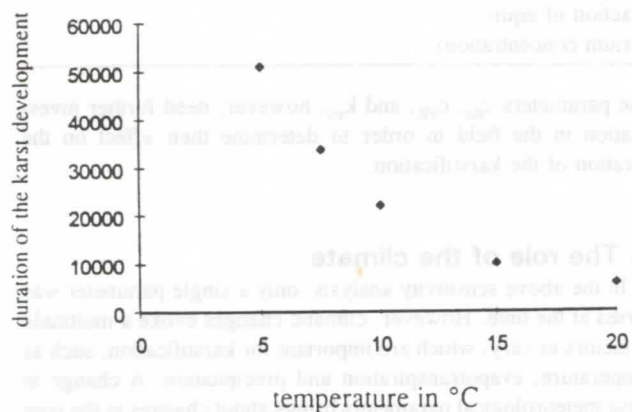

Figure 4: Change in karstification period as a result to a change in temperature

Acknowledgements

This study was supported financially by the Deutsche Forschungsgemeinschaft (DFG) within the context of the Collaborative Research Centre 275 (SFB 275) and by the European Union Contract EV5V-CT94-0471.

References

BERKOWITZ, B., BEAR, J. & BRAESTER, C. 1988. Continuum models for contaminant transport in fractured porous formations. *Water Res. Res.*, 24, 1225-1236.

BUHMANN, D. & DREYBRODT, W. 1985. The kinetics of calcite dissolution and precipitation in geologically relevant situations of karst areas. 2. Closed systems. *Chem. Geol.*, 53, 109-124.

CLEMENS, T., HÜCKINGHAUS, D., SAUTER, M., LIEDL, R. & TEUTSCH, G. 1996. A combined continuum and discrete network reactive transport model for the simulation of karst development. *IAHS Publ.*, 237, 309-318.

CLEMENS, T., HÜCKINGHAUS, D., SAUTER, M., LIEDL, R. & TEUTSCH, G. 1997. Simulation of the development of karst aquifers by using a pipe flow model coupled to a continuum model: 2. Model verification and sensitivity analysis. *Water Res. Res.*, submitted

DREYBRODT, W. 1990. The role of dissolution kinetics in the development of karst aquifers in limestone: a model simulation of karst evolution. *J. Geol.*, 98, 639-655.

DREYBRODT, W. 1991. Principles of early development of karst conduits under natural and man-made conditions revealed by mathematical analysis of numerical models. *Water Res. Res.*, 32, 2923-2935.

FORD, D.C. & WILLIAMS, P.W. 1989. *Karst Geomorphology and Hydrology*. Unwin, London, 601p.

GROVES, C.G. & HOWARD, A.D. 1994. Early development of karst systems, 1. Preferential flow path enlargement under laminar flow. *Water Res. Res.*, 30, 2837-2846.

HORLACHER, H.-B. & LÜDECKE, H.-J. 1992. *Strömungsberechnung für Rohrsysteme*. Expert Verlag 218p.

HOWARD, A.D. & GROVES, C.G. 1995. Early development of karst systems, 2. Turbulent flow. *Water Res. Res.*, 31, 19-26.

HÜCKINGHAUS, D., CLEMENS, T., LIEDL, R., SAUTER, M. & TEUTSCH, G. 1997. Simulation of the development of karst aquifers by using a pipe flow model coupled to a continuum model: 1. Theory. *Water Res. Res.*, submitted

JAMES, A.N. & KIRKPATRICK, I.M. 1980. Design of foundations of dams containing soluble rocks and soils. *Quat. J. Eng. Geol.*, 13, 189-198.

PLUMMER, L.N. & WIGLEY, T.M.L. 1976. The dissolution of calcite in CO₂-saturated solutions at 25°C and 1 atmosphere total pressure. *Geochim Cosmochim. Acta*, 40, 191-202.

PLUMMER, L.N., WIGLEY, T.M.L. & PARKHURST, D.L. 1978. The kinetics of calcite dissolution in CO₂-water systems at 5° to 60°C and 0.0 to 1.0 atm CO₂. *Am. J. Sci.*, 278, 179-216.

PALMER, A.N. 1981. Hydrochemical controls in the origin of limestone caves: *8th Int. Spel. Congr., Bowling Green, Kentucky*, 120-122.

PALMER, A.N. 1991. Origin and morphology of limestone caves. *Geol. Soc. Am. Bull.*, 103, 1-21.

RAUCH, H.W. & WHITE, W.B. 1977. Dissolution kinetics of carbonate rocks. 1. Effects of lithology on dissolution rate. *Water Res. Res.*, 13, 381-394.

Influence d'intercalations carbonatées en milieu sédimentaire à dominance siliceuse sur le chimisme des eaux (Finistère, France).

par Luc Somlette, Jean-Pierre Faillat et Gaël Le Bec

Laboratoire d'Hydrogéologie, ISAMOR, Technopôle Brest Iroise, 29280 PLOUZANE, FRANCE

Abstract

In Brittany, water generally has acid and aggressive characteristics. Nevertheless, water can be locally neutral to basic and have a $\text{HCO}_3\text{-Ca}$ hydrofacies as a consequence of carbonate intercalations in siliceous and aluminosilicate sedimentary rocks. The difficulty is to observe those intercalations because of the thickness of the ground, of the vegetation, and of the weak extension of carbonate outcrops.

This study deals with a river basin near Plougastel-Daoulas (Finistère, France) constituted with Devonian sediments of schistes, sandstones, quartzites and carbonates. We focused our investigation on the hydrochemical characterization of major ions in order to identify and locate those carbonates. The methodology consisted in measuring electrical conductivity and pH of all the brooks and sources, and in taking samples to analyse ions (Ca^{2+} , Mg^{2+} , Na^+ , K^+ , Cl^- , SO_4^{2-} , HCO_3^- , NO_3^-).

Three families of water can be deduced from the statistical analysis of chemical results. Firstly, a Na-Cl hydrofacies due to the influence of the proximity of the sea, secondly an $\text{HCO}_3\text{-Ca}$ hydrofacies due to the presence of carbonate layers, and finally, an intermediate hydrofacies. The localisation of those three families generally agrees with the geological map. Yet, this method precises and completes it. For example, some samples have bicarbonate-calcium facies whereas there is no outcrop of carbonates.

We conclude that it is possible to easily identify and locate the presence of carbonate intercalations with this method using hydrochemical characterization of water in spite of the absence of outcrop or of access difficulties.

Résumé

Difficilement observables à l'affleurement du fait du couvert pédologique et végétal continu et de leur faible extension, les intercalations de bancs carbonatés et de schistes du Dévonien de l'extrémité Ouest du Massif Armoricaïn influencent fortement le chimisme des eaux souterraines, qui présentent alors un hydrofaciès bicarbonaté. Cet hydrofaciès les différencie nettement des eaux exclusivement au contact de roches siliceuses ou aluminosilicatées (grès, schistes). En conséquence, il est ainsi possible de repérer aisément la présence de niveaux carbonatés qu'en bien même leur présence était insoupçonnée, et d'avoir des eaux peu agressives dans une région où cette caractéristique est inhabituelle.

1- Introduction et but

En Bretagne, les eaux superficielles et souterraines présentent généralement un caractère agressif et acide suite à leur contact avec des roches siliceuses ou aluminosilicatées. Mais localement, ces eaux ont un pH neutre à alcalin et ont un hydrofaciès carbonaté calcique. Cette particularité signe la présence d'intercalations de roches carbonatées aisément dissoutes par une eau agressive. L'existence d'un couvert pédologique et végétal continu, la faible extension de ces roches rendent difficiles leur repérage.

L'étude menée sur le bassin versant de Pennaster a permis de tester l'utilisation des ions en solution comme outil facilitant l'identification et la localisation d'intercalations carbonatées en environnement schisto-gréseux au niveau d'un petit bassin versant.

2- Situation géographique, géologique, et hydrogéologie

Le bassin versant de Pennaster est situé au Sud Ouest de Plougastel-Daoulas. Sa superficie est de 40 Km^2 (Fig.1). L'activité est essentiellement maraîchère (fraises, tomates,...), il n'y a pas d'industries et l'habitat est dispersé. Le climat est océanique avec une pluviométrie et une température moyennes annuelles de 1100 à 1300 mm de 11 à 12°C.

Il est occupé par des formations sédimentaires s'étageant du Silurien Supérieur au Dévonien moyen (CHAURIS ET PLUSQUELLEC, 1980), constituées de schistes, grès et quartzites, avec de rares intercalations calcaires que l'on rencontre surtout dans les schistes et calcaires de l'Armorique (Gedinnien supérieur - Siegénien moyen (Fig.1). La fracturation est marquée par l'existence de deux familles de fractures NW-SE et NE-SW.

Les premières observations concernant les phénomènes karstiques dont ces roches sont le siège ont été faites par PLUSQUELLEC (1982). Plus récemment, WAKEFIELD (1993) et AUBRY-DELAFOSSÉ (1995) ont réalisés les relevés topographiques de deux cavités ayant des développements d'une centaine de mètres (Pennanéac'h-Rozégat) et d'une soixantaine de mètres (Pointe de l'Armorique). L'orientation de ces galeries est principalement influencée par des

fractures N40-50 et N80-90. Les concrétions y sont assez rares (quelques planchers stalagmitiques, stalagmites, draperies, ...). Il en est de même du modelé karstique de surface, réduit à quelques dolines dans les environs de Runavel. Cependant, les chenaux sont bien représentés en front de mer et dans les carrières. On ne connaît pas de sources karstiques dans cette région.

Le grès Armoricaïn, le grès de Landevennec, et les quartzites gediniennes constituent des aquifères de fissures.

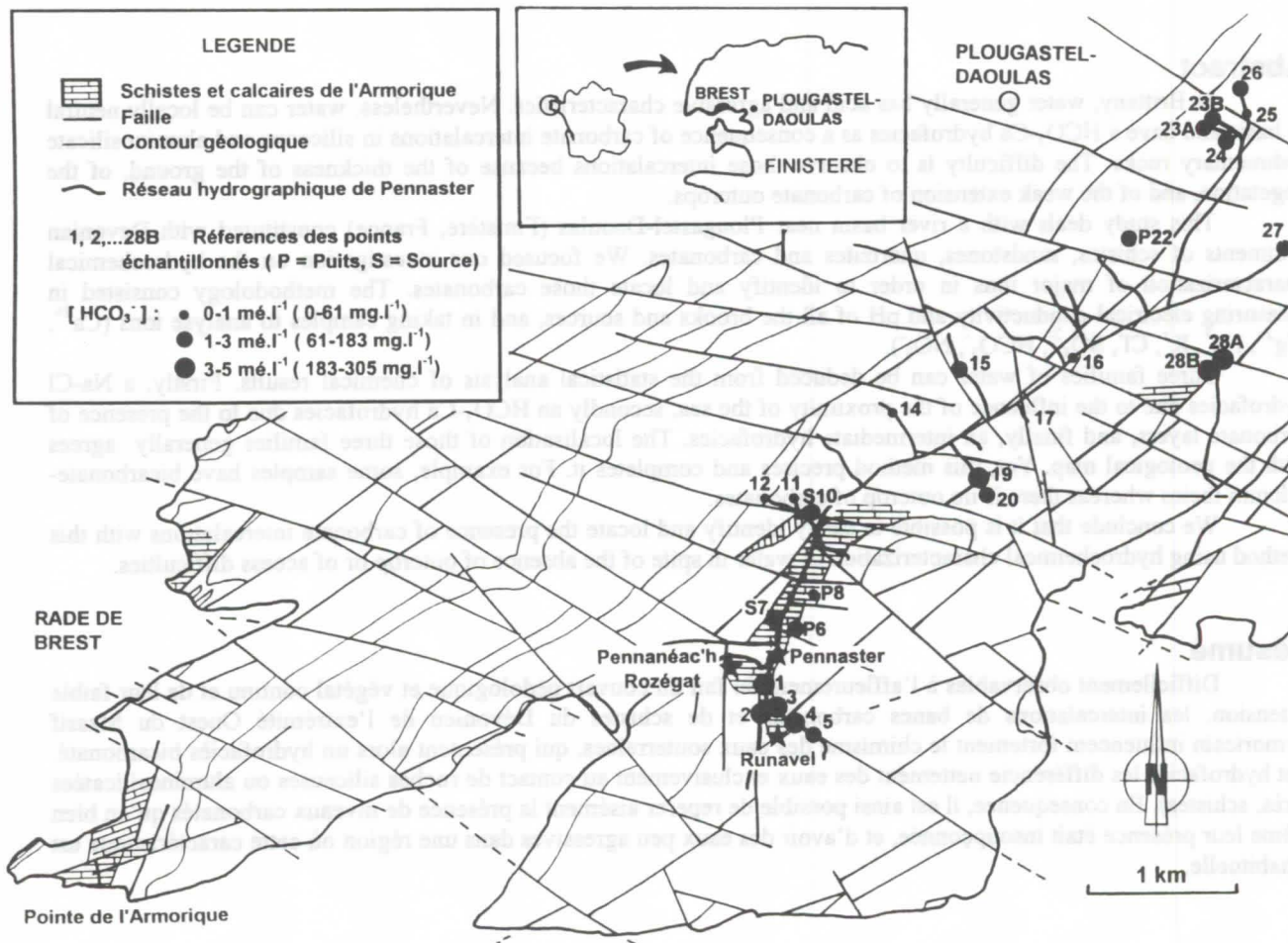

Fig.1 : Localisation géographique et géologie du bassin versant de Pennaster. Position et concentration en HCO₃⁻ des points échantillonnés

3- Méthodologie

Les prélèvements ont été réalisés après plusieurs jours sans pluie. Les eaux de surface et les sources ont été recueillies dans des flacons propres préalablement rincés avec l'eau à analyser puis hermétiquement fermés, en évitant la présence de bulles d'air. Des mesures d'électroconductivité, de pH, et de température ont été pratiquées sur le terrain. La conservation des échantillons s'est faite à l'obscurité et à une température de 4°C. Dès l'ouverture, ont été mesurés l'électroconductivité, le pH, HCO₃⁻ par neutralisation acide, Ca²⁺ et Mg²⁺ par complexométrie, puis NO₃⁻ par spectrophotométrie en U.V., SO₄²⁻ par turbidimétrie, Cl⁻ par la méthode de Mohr et Na⁺ et K⁺ par spectrométrie d'absorption atomique. Le contrôle de la qualité de la conservation des échantillons a été effectué par comparaison des électroconductivités in situ et au laboratoire et la qualité des analyses par le calcul de la balance ionique et sa comparaison avec l'électroconductivité.

Au total, les paramètres physico-chimiques de 39 points (sources, puits, et cours d'eau) ont été mesurés et 26 d'entre eux ont fait l'objet d'un échantillonnage pour dosage des ions au laboratoire (Tableau 1). On constate une évolution sensible de l'électroconductivité de 3 échantillons et la balance ionique est comprise entre -3% et +2% pour 22 prélèvements sur 26 (LE BEC, 1995).

N° inv	1	2	3	4	5	P6	S7	P8	S10	11	12	14	15	16	17	19	20	P22	23A	23B	24	25	26	27	28A	28B	
T (°C)						11,2	8,1	12,5	12,5	11,8	12	12,2	12,0		10,3	12,5	10,6	12,5	11,1	11,6	12,2	10,7	10,8	11,1	12,5	12,3	
EC Terr						706	341	434	431	289	338	230	395	354	456	510	349	345	256	306	352	291	378	419	561	613	
EC Labo	547	477	586	537	581	720	340	430	430	289	340	231	395	326	537	518	355	347	261	308	354	292	327	418	549	615	
pH Terr						6,68	7,00	6,42	6,76	6,93	6,84	7,15	6,96	7,16					6,77	7,13	7,24	6,86	7,14		7,08	7,04	7,05
pH labo	7,58	7,99	7,66	7,50	6,36	6,43	7,40	6,11	6,32	6,76	6,58	6,89	7,88	6,73	6,97	6,8	8,12	6,16	7,37	7,64	6,49	7,26	7,32	7,34	6,98	7,67	
Ca ²⁺	3,36	3,00	3,40	3,36	3,12	1,76	1,76	0,96	1,88	1,08	0,96	0,40	2,32	0,52	3,92	3,12	1,92	1,28	1,44	1,32	1,96	1,40	1,56	2,76	3,80	4,32	
Mg ²⁺	1,20	1,12	1,44	1,76	1,00	1,00	1,00	0,92	1,08	0,81	1,04	0,60	0,92	0,96	1,28	0,72	0,88	0,88	0,48	0,72	0,80	0,68	0,80	0,88	1,00	1,48	
Na ⁺	1,37	0,96	1,33	1,17	1,93	2,65	0,94	1,63	1,40	1,00	1,20	1,17	0,92	0,82	0,70	1,52	0,99	1,27	0,83	0,94	0,87	0,81	0,88	0,92	1,17	1,21	
K ⁺	0,086	0,049	0,091	0,049	0,123	2,020	0,059	0,578	0,169	0,087	0,223	0,020	0,092	0,098	0,066	0,135	0,018	0,249	0,048	0,060	0,077	0,035	0,069	0,065	0,051	0,049	
Σ+	6,02	5,13	6,26	6,34	6,17	7,43	3,76	4,09	4,53	2,98	3,42	2,19	4,25	2,40	5,97	5,50	3,81	3,68	2,80	3,04	3,71	2,93	3,31	4,63	6,02	7,06	
e%	-2,8	-2,4	-0,4	1,1	-2,0	0,0	1,1	-0,5	1,0	1,5	-1,3	0,9	-2,4	0,0	-4,3	-1,8	6,4	1,1	-5,1	-5,7	0,1	0,8	-2,4	-1,0	-1,7	0,1	
Σ-	6,36	5,38	6,31	6,20	6,43	7,43	3,68	4,13	4,44	2,89	3,51	2,15	4,46	2,40	6,50	5,70	3,35	3,60	3,10	3,41	3,70	2,88	3,47	4,72	6,23	7,05	
Cl ⁻	1,27	1,25	1,35	1,15	1,65	1,75	1,00	1,51	1,27	1,10	1,22	1,30	1,00	1,00	0,75	1,35	0,60	1,07	1,00	1,09	1,05	0,92	0,97	0,92	1,10	1,27	
SO ₄ ²⁻	0,84	0,71	0,78	0,80	1,52	1,84	0,68	1,19	0,61	0,69	0,91	0,39	0,76	0,27	0,46	0,59	0,38	0,89	0,67	0,83	0,40	0,67	0,65	0,60	0,98	0,94	
HCO ₃ ⁻	3,93	3,21	3,85	4,05	2,65	2,05	1,69	0,57	1,85	0,77	0,93	0,13	2,37	0,30	5,21	3,49	2,13	1,33	1,17	1,13	1,77	0,89	1,49	2,89	3,61	4,25	
NO ₃ ⁻	0,32	0,21	0,33	0,20	0,61	1,79	0,31	0,86	0,71	0,33	0,45	0,33	0,33	0,83	0,08	0,27	0,24	0,31	0,26	0,36	0,48	0,40	0,36	0,31	0,54	0,59	

Tableau 1 : Résultats des analyses chimiques

Electroconductivité EC en $\mu\text{S.cm}^{-1}$ à 20°C. Concentrations en milliéquivalents par litre (mé.l⁻¹). ε% : Balance ionique

4- Résultats et discussion

La réalisation d'une Analyse en Composantes Principales centrée réduite sur 24 échantillons (Fig.2) montre l'existence de 3 pôles ioniques dans l'espace des variables avec:

- un pôle Cl-Na-SO₄, conséquence de la proximité de l'océan (et secondairement, de la pollution ou de la lithologie pour les sulfates) avec un degré de corrélation de 0.83 entre Na⁺ et Cl⁻,
- un pôle K-NO₃ lié à la pollution,
- un pôle HCO₃-Ca-Mg attribuable aux carbonates dissouts par les eaux agressives. Le degré de corrélation entre HCO₃⁻ et Ca²⁺ est de 0.98

L'espace des individus permet de retrouver 3 groupes de points dont l'existence est liée à l'un des pôles définies précédemment, le plus important correspondant au pôle roches carbonatées. Un quatrième groupe apparaît, constitué d'eaux peu chargées, principalement en contact avec des roches siliceuses, également bien représenté.

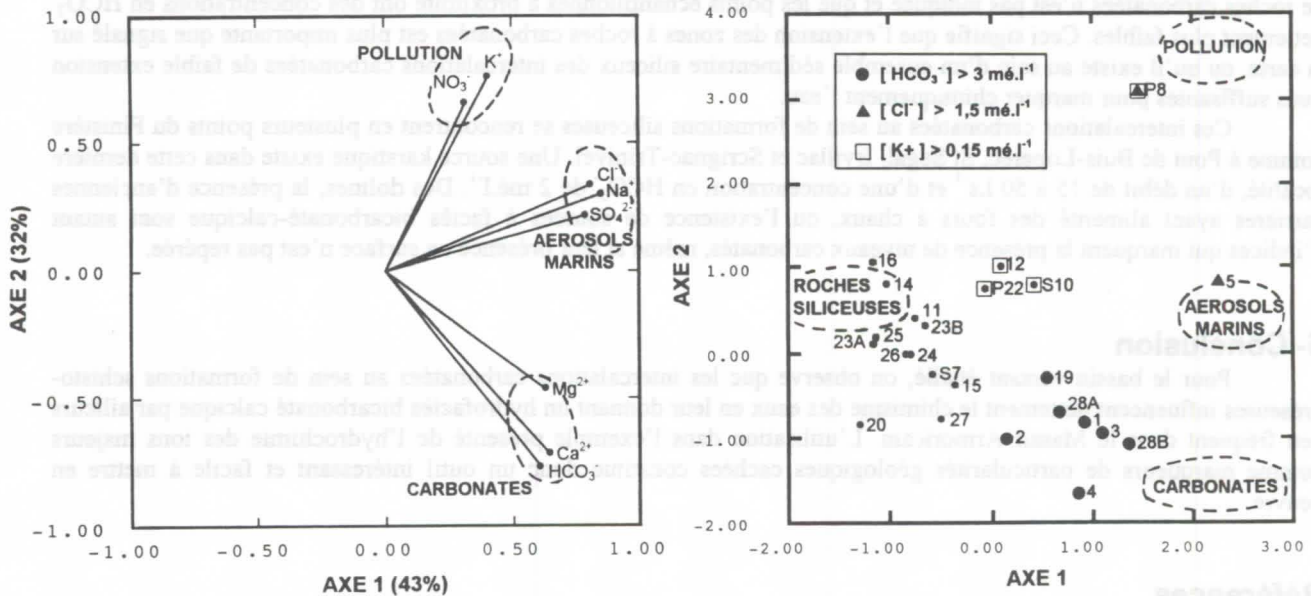

Fig.2 : Analyse en Composantes Principales des prélèvements

Ainsi, à l'échelle du bassin versant, l'influence des roches carbonatées sur la composition chimique des eaux est nettement mise en évidence. Les ions HCO₃⁻ et Ca²⁺ se distinguant clairement des autres éléments, nous avons étudié la part de HCO₃⁻ dans la concentration totale en anions (Fig.3). On distingue 3 familles d'eaux :

- les eaux où la part de HCO₃⁻ est supérieure à la moitié, définissant ainsi un hydrofaciès bicarbonaté calcique.
- les eaux où la part de HCO₃⁻ est inférieure au tiers, correspondant à un hydrofaciès chloruré-sodique.
- les eaux intermédiaires.

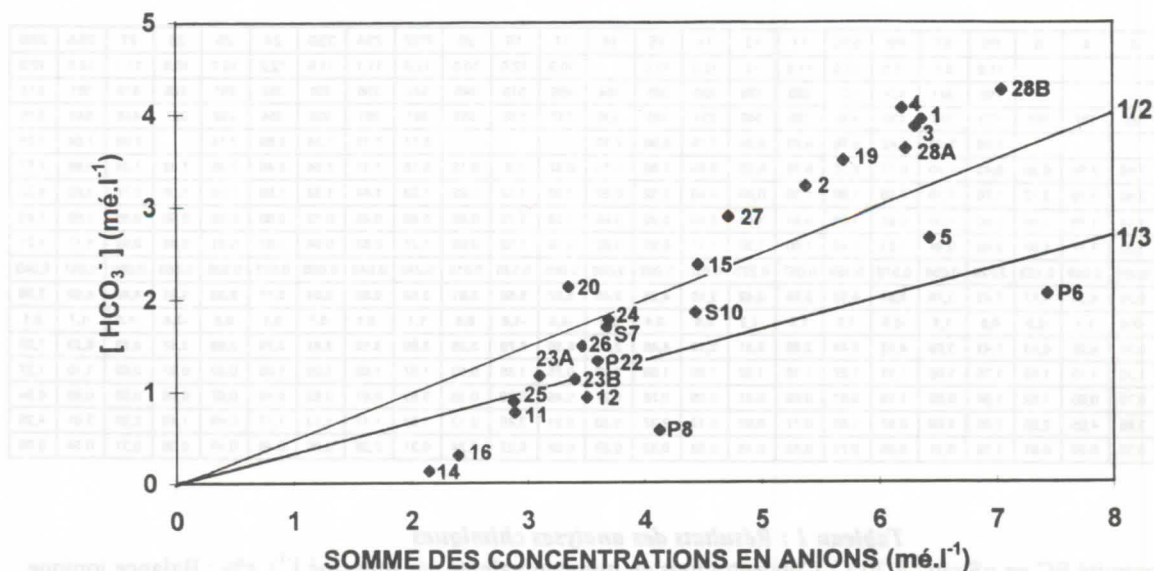

Fig.3 : Relation entre la somme des anions et la concentration en HCO_3^-

L'ACP et la part de HCO_3^- dans la somme des anions montrent que les eaux en contact avec les roches carbonatées ont un faciès hydrochimique se détachant nettement de l'ensemble des eaux du bassin versant, qui ont globalement une composition chimique homogène.

On a reporté sur la carte (Fig.1) la position et la concentration en HCO_3^- de chaque prélèvement, en les comparant à la position des affleurements carbonatés déjà connus (CHAURIS ET PLUSQUELLEC, 1980).

On note que globalement, les plus fortes concentrations en HCO_3^- coïncident avec des zones contenant des roches carbonatées ce qui vérifie la relation évoquée. Cependant, il existe 2 cas où cette généralité n'est pas vérifiée.

- La source S7 et les puits P6 et P8, situés sur une zone à carbonates, ont des concentrations en HCO_3^- plus faibles que prévues (1.69, 2.05 et 0.57 mé.l^{-1} respectivement). Cela peut correspondre à 2 situations : surévaluation de l'extension des roches carbonatées, ou pour le puits, recoupement d'une nappe située dans des altérites ou des alluvions.
- Les points 5, 15, 19, 20, 27, 28A et 28B, ont des concentrations en HCO_3^- de 2.13 à 4.25 mé.l^{-1} alors que la présence de roches carbonatées n'est pas indiquée et que les points échantillonnés à proximité ont des concentrations en HCO_3^- nettement plus faibles. Ceci signifie que l'extension des zones à roches carbonatées est plus importante que signalé sur la carte, ou qu'il existe au sein d'un ensemble sédimentaire siliceux des intercalations carbonatées de faible extension mais suffisantes pour marquer chimiquement l'eau.

Ces intercalations carbonatées au sein de formations siliceuses se rencontrent en plusieurs points du Finistère comme à Pont de Buis-Loperec, St Segal, Irvillac et Scrignac-Trinivel. Une source karstique existe dans cette dernière localité, d'un débit de 15 à 50 l.s^{-1} et d'une concentration en HCO_3^- de 2 mé.l^{-1} . Des dolines, la présence d'anciennes carrières ayant alimenté des fours à chaux, ou l'existence de sources à faciès bicarbonaté-calcique sont autant d'indices qui marquent la présence de niveaux carbonatés, même si leur présence en surface n'est pas repérée.

5- Conclusion

Pour le bassin versant étudié, on observe que les intercalations carbonatées au sein de formations schisto-gréseuses influencent nettement le chimisme des eaux en leur donnant un hydrofaciès bicarbonaté calcique par ailleurs peu fréquent dans le Massif Armoricain. L'utilisation dans l'exemple présenté de l'hydrochimie des ions majeurs comme marqueurs de particularités géologiques cachées constitue donc un outil intéressant et facile à mettre en oeuvre.

Références

- AUBRY-DELAFOSSÉ A.S. 1995 : Etude du contrôle fissural de la karstification et implications hydrodynamiques. Presqu'île de Plougastel. Juin 1995. *Mémoire de Maîtrise*, Dpt des Sciences de la Terre, U.B.O., 30 p., 29 annexes.
- CHAURIS L. et PLUSQUELLEC Y. 1980. Carte géologique de Brest au 1/50 000, 274 IV-17.
- LE BEC G. 1995. Identification hydrochimique de la présence de niveaux carbonatés dans les séries à dominante siliceuses du Paléozoïque de la presqu'île de Plougastel. Juin 1995. *Mémoire de Maîtrise*, Dpt des Sciences de la Terre, U.B.O., 24 p., 3 annexes.
- PLUSQUELLEC Y. 1982. Morphologie karstique dans le Paléozoïque du Finistère. *Penn Ar Bed*, Fév.1982, Vol.13, N°106 : 91-96.
- WAKEFIELD B. 1993. Levés topographiques des grottes de Pennanéach-Rozegat et de la Pointe de l'Armorique. Inédit.

Dissolution et spéléogénèse en contexte tectonique actif : Le massif des Arbailles (Pyrénées-Atlantiques, F)

par Nathalie Vanara

Laboratoire de Géographie Physique Appliquée, Institut de Géographie, Université Bordeaux III, F-33405 Talence Cedex

Abstract

The "Arbailles" massif (700-1200 m) is a folded area of Jurassic and Lower Cretaceous limestones belonging to the North-Pyrenean Zone and characterized by an oceanic mountain climate (2000 mm/yr). We observe four types of aquifers : 1/ the Lower Cretaceous aquifers (bicarbonated-calcite springs) ; 2/ the Jurassic aquifers (bicarbonated-calcic lightly sulfated and magnesian springs) ; 3/ the complex aquifers (bicarbonated-calcic and sulfated springs) ; 4/ the deep aquifers (chlorinated-sodic spring). The mineralization of springs indicates an evolution opposite to that of the discharge, classic in the mountain karsts. Waters are aggressive during summer (low waters, biogenic CO₂) and near the equilibrium or lightly oversaturated during winters (high waters). Nearly 90 % of dissolution occurs between 0 and 100 m deep. The plio-quaternary uplift is responsible for the creation of genetic cave levels and underground stream piracy. The superficial dissolution is the cause of the disappearance of more than 200 m of limestone since the beginning of Pliocene.

Résumé

Le massif des Arbailles (500-1200 m) est situé dans la zone nord-pyrénéenne. Il forme une unité plissée de 165 km², constituée de calcaires jurassiques et crétacés, soumis à un climat océanique montagnard (2000 mm/an). On y distingue quatre aquifères karstiques séparés par des écrans plus ou moins imperméables : 1/ les aquifères du Crétacé inférieur (sources bicarbonatées calciques), 2/ les aquifères du Jurassique (sources bicarbonatées calciques légèrement sulfatées et magnésiennes), 3/ les aquifères complexes (sources bicarbonatées calciques et sulfatées), 4/ les aquifères profonds (source chlorurée sodique). La minéralisation des sources montre une évolution inverse à celle du débit, classique pour un karst montagnard. Les eaux sont agressives durant l'été en période d'étiage (CO₂ biogénique) et à l'équilibre ou légèrement sous saturées pendant le reste de l'année (hautes eaux). Près de 90 % de la dissolution s'exerce entre 0 et 100 m de profondeur. La surrection plio-quaternaire a entraîné un étagement génétique des niveaux de galeries et des captures souterraines d'un bassin karstique à un autre, la tranche de calcaire dissoute en surface étant d'au moins 200 m.

1. Situation et problématique

une unité plissée de 165 km² appartenant à la zone nord-pyrénéenne (figure 1). Il s'agit d'un karst de moyenne montagne (500-1200 m) soumis à un climat océanique montagnard (1500-2000 mm/an). La forte surrection au cours du Plio-quaternaire, estimée à plus de 1000 m, a entraîné un enfouissement des réseaux, un étagement génétique des niveaux de galeries et des captures souterraines d'un bassin karstique à un autre. On observe également une correspondance entre les anciennes galeries noyées étagées et les grands niveaux perchés des vallées sèches (VANARA, MAIRE & LACROIX, 1997). Les recherches spéléologiques ont permis de découvrir plus de 600 cavités et une vingtaine de rivières souterraines (DELAITRE, 1995).

Drainé par 138 sources, ce massif possède des aquifères diversifiés dans le Jurassique et le Crétacé inférieur (figure 2). La majorité des sources présente un débit moyen inférieur à 1 l/s avec tarissement en été ; elles sourdent soit dans les calcaires marneux albiens, soit à la limite des calcaires urgoniens (Aptien supérieur) et des marnes de Sainte-Suzanne (Néocomien-Aptien inférieur). Généralement, les petites sources se perdent rapidement pour alimenter les systèmes karstiques drainés par 15 grandes émergences (> 5 l/s). Ces dernières jaillissent au bas du massif et marquent le niveau de base des grandes vallées (200 m). Les limites des bassins d'alimentation des principales sources ont été précisées par la réalisation de 10 colorations (figure 1) (BAUER, 1995 ; VANARA, 1996).

Les paramètres physiques et les principaux éléments chimiques ont été mesurés pour les huit principales émergences au cours de l'année 1995/96. Ces résultats sont complétés par des mesures de dureté totale et de Ca²⁺ dans différents écoulements souterrains afin de permettre une première appréciation de la dissolution endokarstique actuelle.

2. Fonctionnement hydrochimique actuel des sources

Aquifères karstiques et faciès chimiques

La série lithostratigraphique et les faciès chimiques des sources permettent de distinguer quatre familles d'aquifères karstiques séparés par des écrans plus ou moins imperméables (figures 2 et 3) :

1/ Les aquifères du Crétacé inférieur (calcaires marneux albiens et/ou calcaires massifs urgoniens) sont limités au mur par les marnes de Ste-Suzanne (Néocomien-Aptien inférieur). Les eaux présentent un faciès bicarbonaté calcique classique : HCO₃⁻ (155 à 161 mg/l) et Ca²⁺ (50 à 54 mg/l) représentant 90 % du total de la minéralisation (Grande et Petite Bidouze) ;

2/ Les aquifères du Jurassique (calcaires du Dogger et calcaires et marnes du Lias) sont limités au mur soit par les marnes d'Hosta (Oxfordien) soit par les marnes du Lias moyen et supérieur. Les eaux présentent un faciès bicarbonaté calcique légèrement sulfaté et magnésien (Zahaguy, Urondoa Haute, Uthurbietta) : HCO₃⁻ (155 à 159 mg/l) et Ca²⁺ (51 à 53 mg/l) sont prédominants (83 et 88 %), mais SO₄²⁻ (6 à 19 mg/l) et Mg²⁺ (2 à 4 mg/l) sont également présents ;

3/ Les aquifères complexes de la bordure sud sont caractérisés par la liaison hydrologique entre les différents aquifères due à la réduction d'épaisseur des couches (Trias à Crétacé). Les eaux présentent un faciès bicarbonaté calcique et sulfaté (Arhanzéta, Cent Sources et Garaybie). HCO₃⁻ (152 à 181 mg/l), Ca²⁺ (60 à 73 mg/l) et SO₄²⁻ (50 à 101 mg/l) sont en proportion importante (86 à 88 %).

4/ Les aquifères profonds sont caractérisés par la forte concentration des ions HCO₃⁻ (183 mg/l), Ca²⁺ (494 mg/l), Na⁺ (4368 mg/l), SO₄²⁻ (1065 mg/l) et Cl⁻ (6922 mg/l) (moyenne de deux analyses de la source thermale de Camou à faciès chloruré sodique).

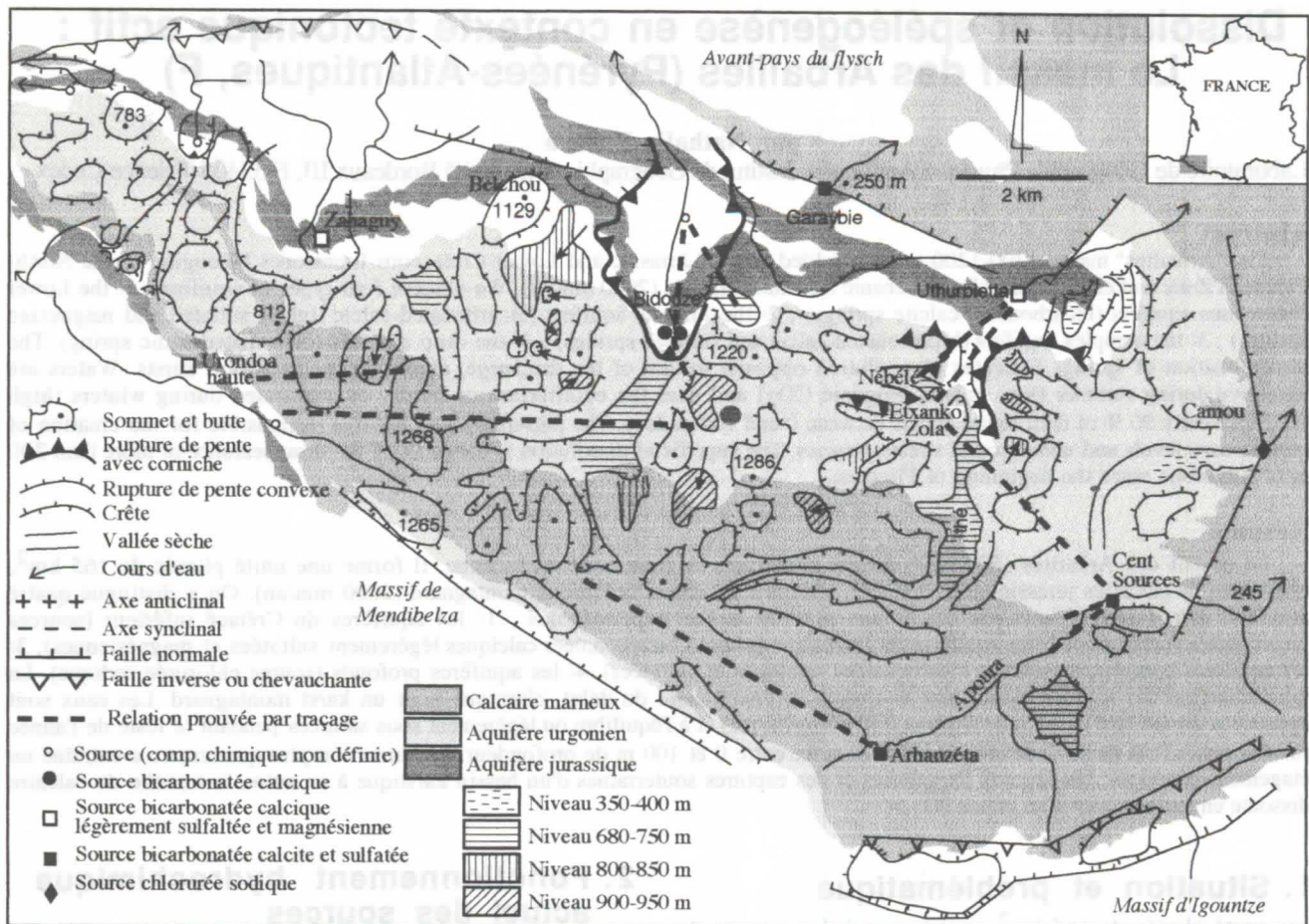

Figure 1 : Croquis hydrogéologique du massif des Arbailles.

Paramètres physiques et régimes chimiques

La moyenne des températures des huit émergences étudiées est de 11°C. Le pH moyen est de 7,6. Les variations saisonnières sont nettes. Le pH est inférieur à 7 en juillet-août et supérieur à 7 le reste de l'année. Le CO₂ dissous (moyenne de 22 mg/l) augmente l'été en fonction de l'activité biologique.

La conductivité des huit sources varie de 274 à 466 µS/cm. La dureté totale, étroitement liée au débit, fluctue de 136 (Petite Bidouze) à 225 mg/l (Arhantzéta). Le TH augmente en période de basses eaux (juillet, août, novembre) et diminue en période de hautes eaux (mai, septembre, hiver). Comme pour le TH, l'évolution du Ca²⁺ est tributaire des débits : valeurs maximales atteintes en étiage, valeurs minimales en crue (phénomène de dilution par des eaux peu chargées venues rapidement de la surface). La moyenne annuelle du Ca²⁺ est de 57 mg/l (50 à 73 mg/l) sur les Arbailles. Les rapports entre le maximum et le minimum vont de 1,3 (Petite Bidouze) à 2,2 (Arhantzéta). La moyenne annuelle du Mg²⁺ des sources va de 0,4 (Uthurbietta) à 10 mg/l (Garaybie), pour une moyenne de 5 mg/l sur l'ensemble du massif.

La moyenne du HCO₃⁻ est de 143 mg/l pour l'ensemble des sources étudiées. Les valeurs des moyennes pour chaque source vont de 152 (Arhantzéta) à 181 mg/l (Garaybie). Les valeurs extrêmes montrent un minimum de 131 et un maximum de 201 mg/l pour des rapports de 1,2 à 1,4. Les fortes teneurs en ions sulfates se manifestent lors des étiages notamment pour trois sources aux aquifères complexes (Arhantzéta, Cent Sources et Garaybie, moyenne annuelle de 71 mg/l). L'aquifère jurassique drainé en partie par Urondoia Haute, Uthurbietta et Zahaguy possède une moyenne de 10 mg/l. SO₄²⁻ est absent de l'aquifère Crétacé (figure 4). La moyenne annuelle des ions

Na⁺, K⁺, Cl⁻, NO₃⁻ et PO₄⁻ est respectivement de 2, 0,5, 6, 3 et 0,03.

On est en présence d'une dissolution relativement classique dans un karst de moyenne montagne forestière du domaine tempéré humide avec des eaux agressives l'été et à l'équilibre ou légèrement sursaturées le reste de l'année en fonction de l'activité des sols et de la végétation (CO₂ biogénique).

3. La dissolution spécifique, épikarstique et souterraine actuelle

Le suivi des principales émergences des Arbailles montre que la moyenne de la minéralisation (alcalinité) est d'environ 160 mg/l de HCO₃⁻ et 165 mg/l de CaCO₃ (TH). A l'altitude moyenne de 900 m (T moy. = 8,9°C), les précipitations annuelles sont de 2029 mm et l'évapotranspiration réelle de 540 mm, soit une tranche écoulée de 1489 mm/an. On estime donc la dissolution spécifique (superficielle et profonde) à environ 92 m³/km²/an, soit 0,09 mm/an.

La dureté totale depuis la zone d'absorption jusqu'aux émergences passe par deux phases d'évolution principales (figure 5) :

1) une augmentation rapide dans la zone épikarstique en raison de la dissolution d'origine pédologique et du régime d'écoulement par percolation et suintement. La dureté passe ainsi en moyenne de 0 en surface à 140 mg/l à -10 m.

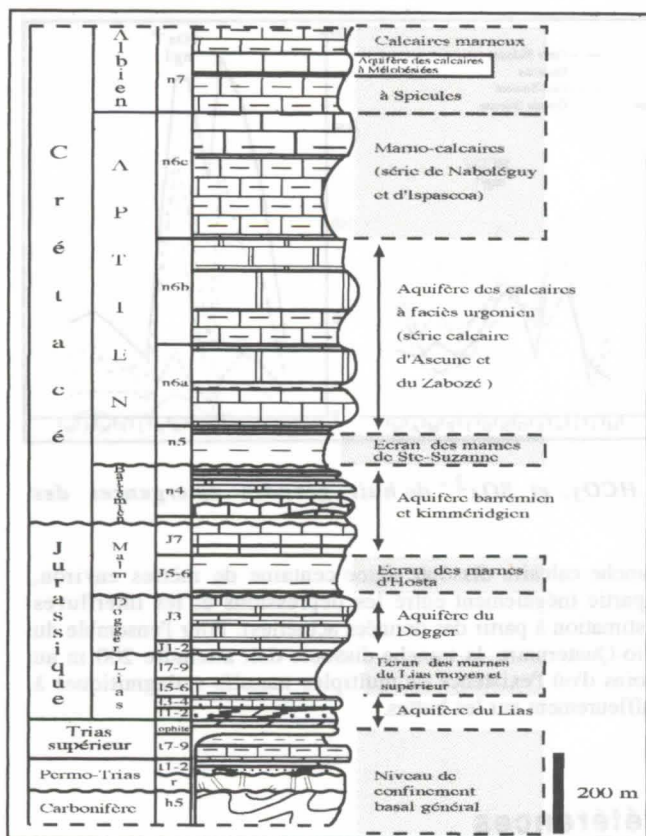

Figure 2 : Echelle lithostratigraphique (d'après Fabre & Navarre, 1992 ; modifié), aquifères et écrans hydrauliques.

2) une augmentation globalement lente dans les rivières souterraines. La dureté y passe de 140 à 170 mg/l environ. Cependant, on observe des valeurs très dispersées selon les types d'écoulements (percolation, suintement, rivière) allant de 100 à 200 mg/l (les percolations étant plus minéralisées que les rivières).

On peut donc considérer que la dissolution se répartit ainsi : 80 à 85 % dans la zone épikarstique et 15 à 20 % dans la zone endokarstique. Près de 90 % de la dissolution s'exerce entre 0 et 100 m de profondeur. Ces résultats sont en accord avec ceux de DELANNOY (1983) qui estime que, dans les karsts forestiers du Vercors, la corrosion préférentielle se produit dans la tranche superficielle du karst : 55 % de la dissolution totale entre 0 et -50 m et jusqu'à 80 % entre 0 et -100 m. Dans les karsts supraforestiers nus, la dissolution entre 0 et -100 m représente 65 % de la dissolution totale (15 % pour la dissolution superficielle).

La porosité karstique diminue en profondeur. Néanmoins, la concentration des écoulements permet de conserver un potentiel de dissolution suffisant pour creuser des galeries importantes qui s'organisent en quelques collecteurs principaux.

4. Les étapes de la spéléogénèse (Fig. 1)

Le karst des Arbailles est une surface héritée, à éléments de plateaux et buttes résiduelles (1000-1250 m), perchée 800 m au-dessus du niveau de base régional. Les reliefs résiduels sont séparés par un système de vallées sèches et par des dépressions et des mégadolines. Plusieurs familles de cavités, dont les plus anciennes sont mises au jour par l'érosion, attestent de

l'ancienneté de la karstification. Certaines présentent des témoins sédimentaires comme celle du Belchou avec sa coulée stalagmitique longue de 17 m et épaisse de 70 cm située au sommet, à 1127 m d'altitude. Ce témoin de grotte subsistant au sommet d'une grande butte indique l'importance de la tranche calcaire érodée depuis le Néogène, date à laquelle se situaient ces anciennes karstifications.

Au Néogène et au Pléistocène, l'ensemble du massif se soulève de 1000 m en plusieurs étapes. Les accidents majeurs des Arbailles sont jalonnés par des sources minérales et/ou thermales. Les sources sulfureuses et ferrugineuses de Garaybie sont situées sur le tracé de la faille chevauchante de la bordure nord. La source chlorurée sodique de Camou jaillit à 30 °C sur le tracé du grand accident décrochant de la bordure orientale (zone sismiquement active). La température et la minéralisation indiquent le lessivage vers 900 m de profondeur des marnes gypsifères du Keuper.

Les vallées sèches et les réseaux souterrains ont enregistré les étapes de la surrection par des niveaux étagés, réajustements des écoulements en fonction de l'enfoncement progressif des vallées bordières. Plusieurs niveaux subhorizontaux sont visibles : 380 m, 700 m, 850 m et 950 m. Le niveau majeur de 700 m est illustré par des tronçons de vallées sèches de 2 à 3 km de long, à faible pente (1 à 3°), qui représentent un important stationnement du niveau de base régional conservé par immunité karstique après la surrection.

Dans le réseau souterrain d'Etxanko Zola, le niveau fossile de 675 m (galerie des Planches à Clous) correspond au niveau subhorizontal de 700 m de la grande vallée sèche d'Ithé. A la suite de la surrection, la galerie s'est asséchée de même que la conduite forcée de la zone d'entrée. La capture des eaux souterraines du réseau d'Etxanko Zola vers le nouveau niveau de base de l'Apoura (Cent sources) s'est effectuée à la faveur du pendage général vers le S et le SW.

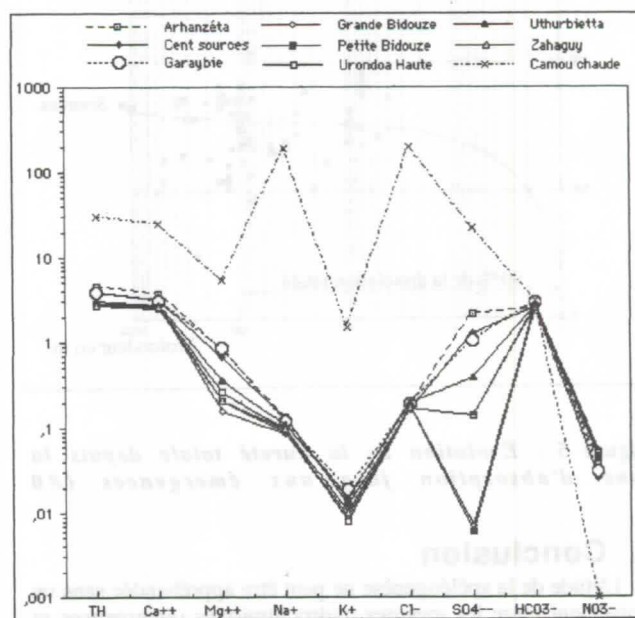

Figure 3 : Diagramme de Schoeller-Berkaloff : les faciès chimiques de neuf émergences des Arbailles.

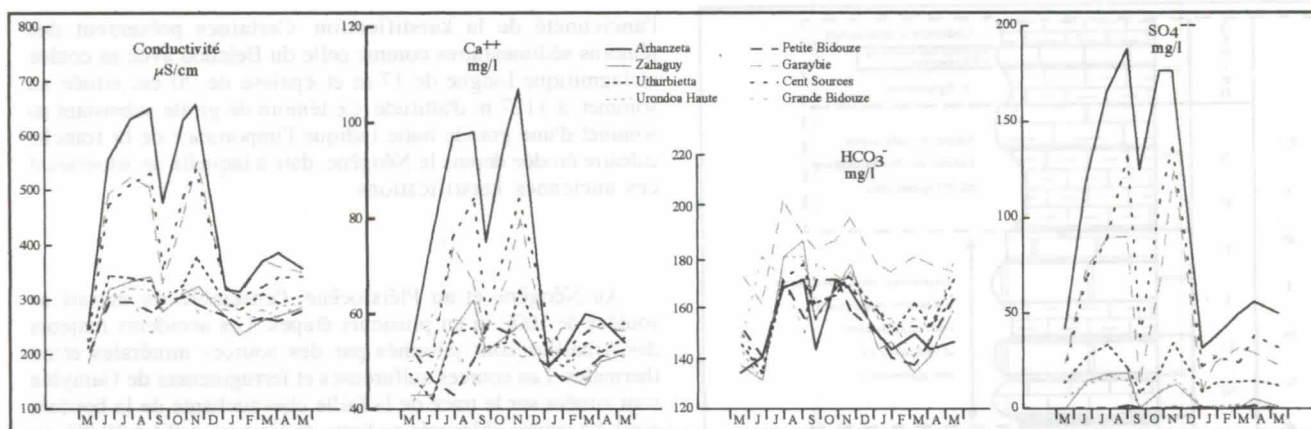

Figure 4 : Evolution de la conductivité, des ions Ca^{2+} , HCO_3^- et SO_4^{2-} de huit grandes émergences des Arbailles (Année 95-96).

Plus bas, un autre jalon est donné par le niveau subhorizontal de 365 m du Nébélé, dont la morphologie indique un creusement en régime noyé en correspondance avec un ancien niveau de base de la vallée d'Ithé. A la suite de la surrection, la galerie s'est asséchée permettant le dépôt de spéléothèmes. En datant la calcite de la génération de stalagmites la plus ancienne du niveau de 365 m, on date le début de l'assèchement et par conséquent l'âge de la surrection. La génération la plus ancienne a un âge U/Th de 407 000 ans (+ 78 700, - 46 600) (analyse Y. Quinif, CERAK, Mons). On estime donc que le massif s'est soulevé de plus de 150 m en 400 000 ans environ, soit un taux de surrection de 0,4 mm/an.

tranche calcaire dissoute d'une centaine de mètres environ, répartie inégalement entre les dépressions et les interfluves (estimation à partir des données actuelles). Pour l'ensemble du Plio-Quaternaire, la tranche dissoute doit atteindre 200 m au moins d'où l'existence de multiples massifs stalagmitiques à l'affleurement sur les buttes.

Références

- BAUER, J. 1995: Le massif des Arbailles. Iteko Ohiana. Comité Départemental de Spéléologie des Pyrénées-Atlantiques, 15 p.
- DELAITRE, E. 1995: Massif des Arbailles, base de données. Comité Départemental de Spéléologie des Pyrénées-Atlantiques, Pau, 375 p.
- DELANNOY, J. J. 1983: Le complexe souterrain du plateau du Sornin (Vercors, France), le gouffre Berger et le Scialet de la Fromagère. *Karstologia*, 2, 3-12.
- FABRE, C. et NAVARRE, J.C. 1992: Le mésozoïque du bloc des Arbailles : structuration et sédimentation. IFP, ENSPM, SNEA, Univ. Paul Sabatier, Toulouse, 127 p.
- MAIRE, R. 1990: La haute montagne calcaire. *Karstologia-Mémoires*, n°3, 731 p.
- VANARA, N. 1996: Synthèse des expériences de coloration sur le massif des Arbailles. Comité Départemental de Spéléologie des Pyrénées-Atlantiques, Pau (inédit).
- VANARA, N., MAIRE, R. & LACROIX J. 1997: La surface carbonatée du massif des Arbailles (Pyrénées-Atlantiques) : un exemple de paléoréseau hydrographique néogène déconnecté par la surrection. *Bull. Soc. géol. France*, 168, 2. (sous presse)

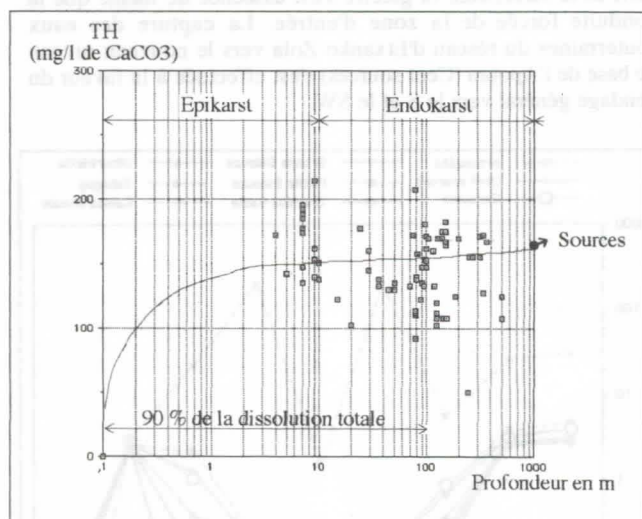

Figure 5 : Evolution de la dureté totale depuis la zone d'absorption jusqu'aux émergences (80)

5. Conclusion

L'étude de la spéléogénèse ne peut être appréhendée sans un croisement entre les mesures hydrochimiques (émergences et cavités) et les observations géomorphologiques effectuées au niveau de l'exokarst et de l'endokarst. Or la répartition de la dissolution du karst montre une prépondérance du creusement dans la zone épikarstique (80 %) en contexte forestier. En outre, l'estimation de la tranche de calcaire dissoute doit tenir compte des changements climatiques et de la présence ou non d'une couverture végétale. Pour le Pléistocène, on peut admettre que pendant la moitié du temps le massif était dépourvu de couverture forestière (périodes froides), d'où une

Microbiological processes at the cave development and karstification

Benjamin Menne

BIUS, Hartfeldstr.32, D-75417 Mühlacker (Germany)

Abstract

The process of karstification can be regarded as part of the carbon-cycle of the earth. The assumption that microorganisms could play a role at the Speleogenesis was repeated in the past. To a great extent, these considerations have been intensively contradicted. Microbiological sediment researches in European caves led however to new cognitions. The possible role of microorganisms at the karstification is represented with the models of the "Carbonatolyse" and "Bioconservation". Basis of these models is the "Festbettreaktor" (trickling filter), a common type of sewage water treatment.

The formation of biofilms is described both as model and as experimental examinations. Data from some cavesystems are introduced. The consequences of the results for the karstwater and its use are briefly explained.

Der Vorgang der Verkarstung kann als Teil des Kohlenstoffkreislaufes betrachtet werden. In der Vergangenheit wurde wiederholt die Vermutung geäußert, daß Mikroorganismen eine Rolle bei der Sepläogenese spielen könnten. Diesen Überlegungen ist teils heftig widersprochen worden. Mikrobiologische Sedimentuntersuchungen in europäischen Höhlen führten jedoch zu neuen Erkenntnissen. Die mögliche Rolle von Mikroorganismen bei der Verkarstung wird anhand der Modelle der "Carbonatolyse" und der "Biokonservierung" dargestellt. Grundlage dieser Modelle ist der Festbettreaktor. Die Bildung von Biofilmen wird sowohl modellhaft als auch experimentell untersucht. Daten aus ausgesuchten Höhlensystemen werden vorgestellt. Die Konsequenzen der Befunde für das Karstwasser und seine Nutzung werden kurz erläutert.

Results and Discussion

It is obvious that the corrosion of limestone is a surface-chemistry mechanism. For this the structure and condition of the inner surfaces of the karstsystem are most important. Surprisingly, we know only a little about the real circumstances of the crack and fissure surfaces. During the last decade, we examined hundreds of sediment samples of European caves. We found that there is a high variety and diversity of the subterranean microbiocoenosis, but there are as well clearly perceptible common facts. We discovered - for example - that the karstic rock-mass is divided into some mainly vertical microbiological reaction zones : Subcutum, Epiklasal, Hypoklasal and Hydroklasal (MENNE 1997). The complex three-dimensional structure of microbiocoenoses within the karst systems leads to questions about the occurrence of biofilms at the crack-surfaces. We realized that the existence of biofilms is clearly indicated. There are also high-complex microbiological structures on the fissure-surfaces.

Biofilms cover surfaces. The first step in the process of bacterial attachment and biofilm formation on crack-surfaces is adhesion-mechanism (adsorption). Three-dimensional growth is possible. Even if the biofilms, including perhaps abiotic components (for example clay-particles), develop on the fissure-surface without attacking the limestone, the corrosion conditions change drastically. We term this hypothetical situation „Bioconservation“. On the other hand, generally, all kinds of microorganisms are able to attack and degrade materials. The deterioration is caused by the excretion of metabolic products (SAND 1996). One of the most common products is carbon dioxide. Within biofilms relatively high concentrations of carbon dioxide are possible. The production of other acid substances was observed by technical methods. The destruction of natural stones by means of biodeterioration processes are proved (WARSCHEID & KRUMBEIN 1996). This indicates that these processes can also take place in karstsystems. We term this „Carbonatolyse“.

Literature

MENNE, B. (1997) : Myxobakterien in der Rettenbachhöhle und in einigen Kleinhöhlen des Sengengebirges - Eine karstmikrobiologische Studie. Karstprogramm 1996 unver. Forschungsber. d. Nationalparks Kalkalpen (Oberösterreich); 34 S.

SAND, W. (1996): Microbial Mechanisms - in : HEITZ, E.; FLEMMING, H.-C.; SAND, W. (Eds.): Microbially Influenced Corrosion of Materials. Springer

WARSCHEID, TH.; KRUMBEIN, W.E. (1996) : Case Histories - Inorganic Non-Metallic Materials - General Aspects and Selected Cases - in : HEITZ, E.; FLEMMING, H.-C.; SAND, W. (Eds.): Microbially Influenced Corrosion of Materials. Springer

Seasonal Fluxes of Humic Substances in Cave Drip Waters, Marengo Cave, Southern Indiana.

P.E. van Beynen, V.A. Toth, D.C. Ford and H.P. Schwarcz

School of Geography and Geology, McMaster University, Hamilton, Ontario L8S 4K1, Canada

Abstract

Water samples were collected for 15 months and analyzed for their fluorescence and DOC content. A positive relation was apparent between total fluorescence and the DOC content of the cave water through four sites within the cave. However, some sites produced stronger relations than others. Seasonal variability is evident, but again this varied from site to site. Spectroscopic studies suggest the fluorescence is attributable to organic acids, most particularly fulvic acid (FA). Ultrafiltration experiments add weight to this finding as most of the organics present in the cave water were less than 1000 MWCO, a range characteristic of FA.

Rationale

The paleoenvironmental significance of this study is related to annual bands of calcite growth in speleothem which have been discovered using luminescence microscopy. These determinations are only possible if the seasonal fluctuations in organics are being recorded in the calcite. Drip water entering the cave which feeds the speleothem must contain a seasonally variable organic concentration. Through weekly collection of cave water and its analysis using techniques outlined above, any variability can be ascertained. Comparisons between variability of organic content and climate factors could result in the creation of relations between climate and fluorescence of speleothem. Future testing of these relations using speleothem of known modern age from similar climatic regions could be undertaken.

Study Area

Marengo Cave, Southern Indiana (latitude 38°22'N, longitude 86°20'W) is optimal due to ease of access, seasonal variability of locale, cooperation of cave staff in sampling, and a lush temperate deciduous forest above the cave producing significant amounts of organic matter. Marengo Cave is contained within the Ste. Genevieve limestone with the Paoli limestone overlying it and capped by the West Baden Sandstone. Cave water was collected at four sites within the cave over a 15 month period.

Methods

DOC levels were attained using a Dohrmann DC-180 Carbon Analyzer. A Model 10 Turner fluorometer was used to establish the total fluorescence intensity of all samples. A Perkin-Elmer LS-5 Fluorescence Spectrophotometer recorded the spectra as collected with 5nm slit-widths for the monochromator. Ultrafiltration was carried out using 0.45µm, 10,000, and 1,000 MWCO pore size Millipore Pellicon cassette membranes. Molecular weight fractionations coupled with DOC values help ascertain which dominant sizes are present.

Results

DOC and total fluorescence analyses reveal that spring is the period of greatest influx of organics into the cave. This coincides with warmer temperatures and associated snow melt. A reasonable positive correlation is also evident between fluorescence and organic concentrations of drip water. Spectroscopic analysis suggests that FA is the dominant organic substance in the water. Peak fluorescence emission values were recorded at 425nm, a wavelength characteristic of FA although at lower excitation wavelengths than expected (280nm). Molecular weight separations revealed through DOC values suggest that the soluble organics are mostly below 1000 MWCO, demonstrative once again of FA. Relationships to climatic variables have still to be determined, though preliminary results show the influence of storm events on fluorescence.

Conclusion

The above results provide important information for the paleoenvironmental work to be done on interpreting fluorescence in speleothem. Seasonality in cave waters lends support to the existence of annual bands in speleothem. For the interpretation of the fluorescence generated by speleothem, meaning is given by the relation between fluorescence and organic carbon content in drip water. The characteristics of this organic matter is revealed through spectroscopy as probably fulvic acid and through ultrafiltration as small molecular weight compounds, again indicative of fulvic acid.

Systematic Evolution of Subterranean River Caves

Zhu Xuewen

Institute of Karst Geology, Chinese Academy of Geologic Sciences;
40 Qixing Road, Guilin 541004, Guangxi, P.R.China

Abstract

There are thousands of underground river cave systems in karst regions in Southern China. The author based his study on an input-output system of material and energy (usually is a hydrologic system), proposes a new plan for the classification of underground river caves; believes that caves of the different parts of the system should be developed by reciprocal inhibition and synergy under the control of the entirety of the system; and explains the characteristics and the evolution pattern of the caves of all types.

Cave genetics take a very important position in Karstology. Davis (1930) proposed a two-cycle genetic model for limestone caves, and believed that caves was first formed in the phreatic zone and then lifted up to the vadose zone at later stage. Nowadays, genetic theories concerning karst caves such as vadose-origin, phreatic- origin and underground water table-origin are also well known to us. Ford (1989) has put forward a Four- State Model to describe how limestone caves are developed from phreatic zone to ground water table. Till now, the existing speleo-genetic theories are still isolated from one another.

Noticing that there are a great many of subterranean river systems developed in karst regions in Southern China, and because the formation and evolution of karst caves could definitely be ascribed to a certain input-output systems of material and energy, we have established a new model to explain the formation and development of subterranean river caves on the basis of the results of the simulation experiment by Ewers (1982). First, we distinguish the input - output movement of material and energy within an independent genetic system into lateral, planar, and multiple input three basic types; consequently caves of the genetic system could consequently be classified into input, output, and aquifer caves of three fundamental types (Fig.1). Input caves mainly consist of vadose and water table cave, output cave is dominated by water table cave, and aquifer cave is normally characterised by phreatic cave (including deep phreatic zone). In this new model, we bring every basic cave-genesis theory into an organic genetic system. In geomorphic history, it is quite usual to observe caves of all types being uplifted into vadose zone.

The research shows that, the development, enlargement, and extension of input cave usually start from the input point; and the principal input cave normally has a relatively fast development and high developing intensity in comparison with output cave within the same underground river system. During the formation of an underground river cave, the retrogressive erosion only occurs in the late development stage of the output cave when conduit water flow becomes turbulent. The development of an aquifer cave is of high degree of selection in different stages, and most aquifer caves will stop developing and gradually be abandoned as they will have no water flow, as water flow in the aquifer tends from initial disorder to an ordered state.

The main evolution stages of an underground river cave system are as follows (Fig.1):

1. Early stage of the formation of a karstic hydrologic input-output system: with the formation of an independent, relatively stable input-output hydrosystem, the hydrologic and hydrogeologic process has completed preliminary ordering; the principal input cave has been ascertained and accelerated development; output cave still occurs as karst spring; and aquifer caves are dispersed and in a disordered state.
2. Main stage of the ordering development of the input- output hydrosystem: Input cave speeds up the extension and enlargement process; output cave starts to be formed and develops into the inner part of the aquifer with retrogressive erosion; and aquifer caves are selected to develop intensely.
3. Breakthrough stage of the input-output cave system: Output cave and the principal input cave are connected with each other and become a well- drained passage in the aquifer; the underground hydrologic network becomes mature and the underground cave system has been formed; most of the early developed aquifer caves are abandoned; Water table cave is the dominant landscape in cave development. The collapse skylights occurred on the surface along the main underground river cave, and even part of the underground river course exposed to the surface.

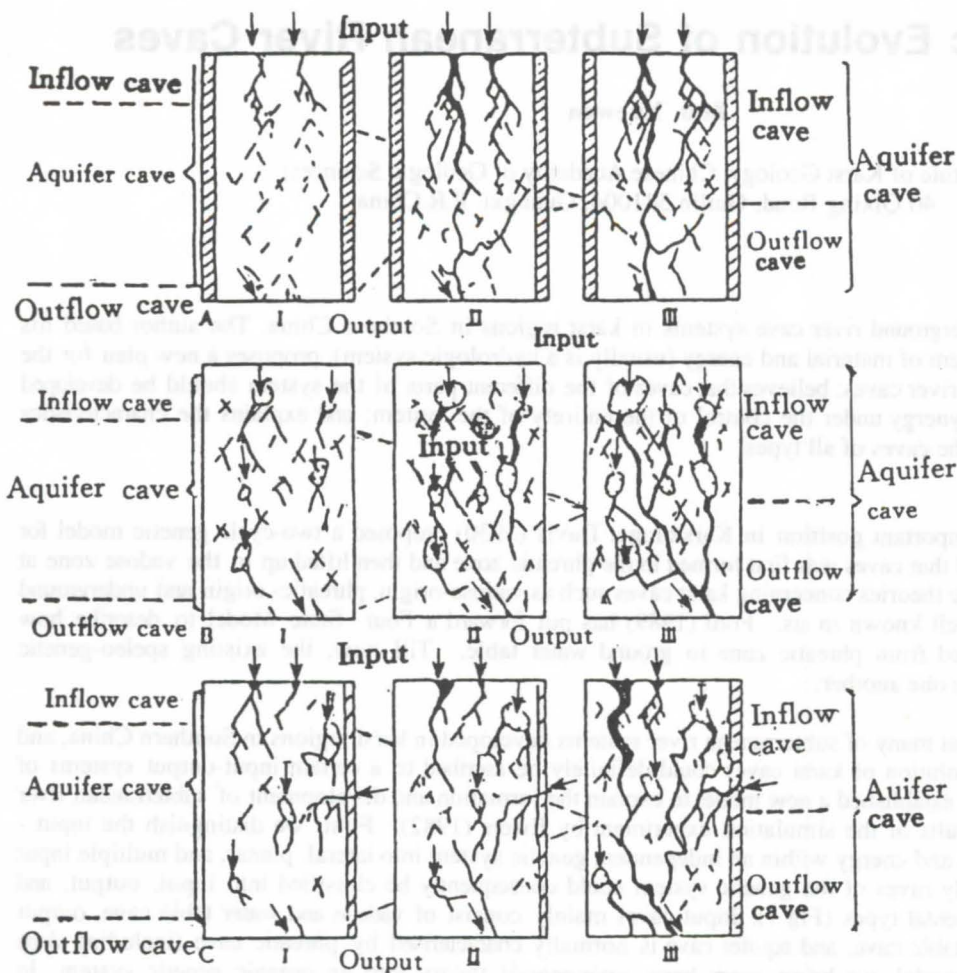

Fig.1 The model of cave development and its systematic evolution in an underground river system.

**A-lateral input; B-Planar input; C-Multiple input;
I, II, III -Evolution stages**

The systematic evolution model of underground river cave is, very useful to study and distinguish the natural feature and the evolution stage of underground river systems in Fengcong mountain areas of South China, and helpful for the exploration and exploitation of karst water resources.

References

- BOGLI A. 1980. Karst Hydrology and physical speleology. Berlin: Springer.
 DAVIS W.M. 1930. Origin of limestone caverns. Geol.Soc.Amer.Bull.
 EWERS R.O. 1982. Cavern development in the dimensions of length and breadth. Ph.D thesis. McMaster University.
 FORD D.C. and WILLIAMS P.W. 1989. Karst geomorphology and hydrology. Unwin Hyman Ltd. London.
 ZHANG REN. 1993. New consideration on classification of karst caves. Proceedings of the international congress of speleology. Beijing.
 ZHU XUEWEN. and ZHANG REN. 1993. The formation and evolution of Nandong underground river system, Yunnan. Proceedings of the international congress of speleology, Beijing.
 ZHU XUEWEN. ZHANG REN. ZHANG YUANHAI. 1995. Karst and caves in Xingwen stone forest area, Sichuan. Carsologica Sinica, Supplement(in Chinese).
 ZHU XUEWEN. ZHANG YUANHAI. ZHANG REN. et al. 1996. Cave development and its systematic evolution in an underground river system, Carsologica Sinica. No.1~2. Vol.15.

Characteristics of hydrochemical responses to environmental change in a carbonate rock Aquifer

Yuan Daoxian

The Institute of Karst Geology
Guilin, Guangxi, China 541004

Carbonate rock, the biggest carbon reservoir on the Earth, is the result of the processes in geological history that reduced the CO_2 content in the atmosphere. By this way, it has played an important role to make the Earth's environment favourable for the development of life and human beings. However, it is considered that this big carbon reservoir is no longer active in the modern carbon cycle since the time scale of mankind.

Recent works show that carbonate rock is still sensitive to global carbon cycle, and has impact on Man's environment both macroscopically and microscopically. These ideas could be explained with a minor example. In Fangtang village, Liujiang county, Guangxi, China, people suffered from the acidic water of a spring which is their major source of water supply, and recharged by a siliceous rock aquifer of Upper Permian. However, in a farmer's private well sunk in the same aquifer just 50m away from the spring, the water is neutralized quickly and improved remarkably because the well is lined by limestone blocks (Fig.1).

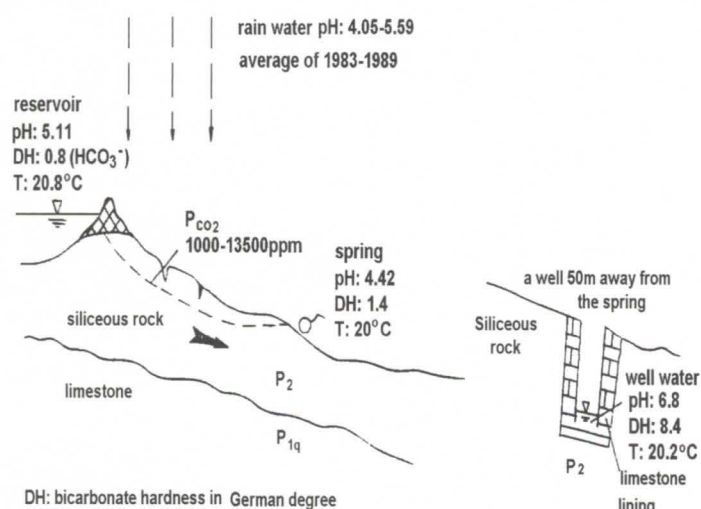

Fig.1 Hydrochemical contrast between waters from the same siliceous rock aquifer, but different in limestone lining, Fangtang village, Liujiang county, Guangxi, China

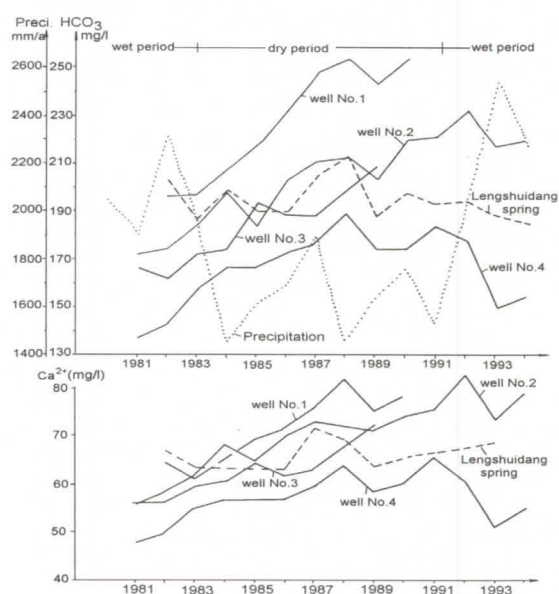

Fig.2 General trend of HCO_3^- , Ca^{2+} rising in a Devonian limestone aquifer of Guilin, China during the past decade, and its impact from change in precipitation (after Liu Jingrong, 1996)

The increase in atmospheric CO_2 following the increasing use of fossil fuel will result in the intensification of carbonate rock dissolution and high content of Ca^{2+} , Mg^{2+} , and HCO_3^- in water. However, the process is highly influenced by climatic factor. Long term hydrochemical monitoring in Guilin (1981-1994), Guangxi, China shows not only a general increasing trend of Ca^{2+} , Mg^{2+} , and HCO_3^- in limestone or dolomite aquifer, but also their higher content in the dry period (1984-1989), and lower at the wet periods (Fig.2, Liu Jingrong, 1996).

The hydrochemical responses of carbonate rock aquifers to acidic water from mining areas, such as pyrite-contained coal mines mainly appeared as the increase in sulfates hardness. The over exploitation of water resources from an evaporite-mixed carbonate rock aquifer has the similar result, but their contributions can be distinguished by an isotopic-hydrological model based on sulphur isotopic data.

The behaviour of heavy metal pollutants, such as Cd^{2+} , Cu^{2+} , Pb^{2+} , Zn^{2+} etc. in a carbonate rock aquifer are mainly reflected as to their absorption by the wall rocks. The phenomena are observed both in laboratory experiments or field practices. However, where do they stay, how and when will they be mobilized again, remain a concern.

Nature and transport of natural colloids in a karstic aquifer

Olivier ATTEIA

Centre d'Hydrogéologie, Rue Emile Argand 11, CH-2007 Neuchâtel, Switzerland.

Abstract

This paper presents a study of colloids and particles in a karstic aquifer of the Swiss Jura. The studied site has been chosen for the presence of clay layers and peats, area able to generate colloids. The study of particle size distributions (PSD) shows that all curves can be fitted by the same model distinguishing large particles, the number of which depends on flow conditions, and small ones influenced by pH. The breaking point is considered to be the limit between colloids and particles. The analysed colloids consist mainly of clays, quartz and complex particles made of organic matter, Ca and Fe. The formation and evolution of colloids and their role on contaminant transport are discussed.

Résumé

Nous présentons ici l'étude de colloïdes et de particules dans un aquifère karstique du Jura Suisse. Le site a été choisi en raison de la présence de marnes et de tourbières qui peuvent libérer des quantités notables de colloïdes naturels. Les courbes de distribution de taille des particules rencontrées peuvent être ajustées par un modèle séparant grosses particules dont le nombre dépend des conditions hydrodynamiques alors que les petites sont reliées au pH. Ceci nous permet de séparer colloïdes et particules. Les colloïdes analysés sont principalement constitués d'argiles, de quartz et de particules complexes imbriquant matière organique, Fe et Ca. La formation et l'évolution des colloïdes sont discutées ainsi que le rôle éventuel des particules dans le transport de polluants.

1. Introduction

Particles are generally considered as colloids when their size implies a long settling time in water, typically from days to months. In natural waters colloids are usually clays, iron (oxihydr)oxides, silica, organic matter and bacteria. Concerning their chemical properties, colloids are often defined as charged species and solids having large specific areas (BUFFLE & LEPPARD 1995). This implies a high reactivity which justifies their ability to transport contaminants.

Colloid studies on karstic aquifers are of major interest for two main reasons: (i) these aquifers are highly vulnerable to contaminants (DOERFLIGER & ZWAHLEN 1994) and therefore any potential contaminant carrier must be studied, and (ii) the discharge variations are very large (KIRALY 1988), thus enabling the study of colloidal behaviour in very different hydrodynamic conditions. The uniqueness of karst and the developing concern for colloids incited the study presented here.

This paper gathers two aspects of colloids: (i) the evolution of Particle Size Distributions (PSD), and (ii) their chemical and mineralogical characteristics. In fact PSD and particle type are both necessary to understand the role of colloids on contaminant transport. The analysis of PSD variation is very useful as no other information exists on karstic aquifers. Beside, we would like to analyse the role of the specific hydrodynamic properties of karstic aquifers on the particulate and colloidal transport. The characterization of colloids is of primary importance for contaminant transport because the sorption properties strongly differ between colloid types. The analysis of colloid mineralogy, composition and morphology at several points of the basin should also outline the effect of solution chemistry on the colloid behaviour.

2. Site

The 60 km² Noiraigue basin is located in the Swiss Jura mountains at an altitude ranging from 1000 to 1350 m. Average rainfall, over the last 70 years, was about 1500 mm/y. The catchment area is represented by (i) a flat valley ('Vallée des Ponts') covered after the last glaciation by peat-bogs, and

(ii) the surrounding calcareous anticlines. The Noiraigue Spring is the only outlet of this karstic aquifer and lies at 750 m, flowing at the outcrop of a regional fault. Fine Molasse sandstone covers the limestone in the centre of the valley with a maximum thickness of 300 m. These tertiary sediments of low permeability are overlaid by thin glacial till and post-glacial marly deposits. Finally, during the last 6000 years peat was formed on these low permeability deposits, covering approx. 20 km². The other two-thirds of the catchment basin are composed of limestone anticlines covered by thin organic- and Ca- rich soils. The Bied brook, draining the remaining peat areas and the agricultural soils of the valley, ends in a karstic sinkhole located in the Cretaceous rocks. The karstic network is well developed with water velocities varying typically from 10 to 60 m/h and discharge ranging from 0.5 to 20 m³/s.

The quaternary marly layers covering the valley are potential sources of colloidal clays. Peat areas should be able to deliver very large amounts of fulvic and humic acids as they contain more than 90% of organic matter (MATTHEY 1986). When ferrous iron coming from the anoxic peat layers will enter in contact with oxic waters, it will precipitate and can therefore form colloids.

The site is equipped for continuous measurements of water level, temperature, electric conductivity, turbidity, and rainfall on the Bied brook and at the Noiraigue spring. Samples were taken almost weekly from May 94 to November 95 for chemical and particle analysis. During some high flow events, samples were taken automatically at shorter time intervals.

3. Methods

Size analysis

The PSD data presented here were obtained by single particle counting. The used CIS Galai apparatus counts individual particles from 0.5 to 60 µm by measuring the duration of the shadowing of a rotating laser light by particles. There is no need for any pre-treatment or fractionation of the sample. This technique has been applied under continuous flow (50 ml/min) and stirring conditions. Three repetitions were

always carried out (JANTSCHIK ET AL. 1992) and the analysis was done until the reproducibility was sufficient.

Different tests were performed to assess the quality of the PSD determined by CIS. Three cultures of bacteria were counted by epifluorescence and by CIS; the standard deviation between the two techniques was lower than 20% for a range of more than one order of magnitude. For one campaign, CIS data were compared with particle counting on Nuclepore filters of 2, 0.8, 0.2 and 0.05 μm . Three pictures of each dried filter were taken by scanning electron microscopy (SEM). 1500 particles were then measured and counted by using an image analysis software. The two techniques agree well, with a difference lower than 25% for measurements over several orders of magnitude.

Particle composition

Filtration has been used to fractionate the samples. Knowing the important constraints on filtration (BUFFLE et al. 1992, MCDOWELL-BOYER et al. 1986), we developed a cascade stack with Nuclepore 2.0, 0.8, 0.2 and 0.05 μm filters (47 mm \varnothing). For the three initial filtration steps, the suspension is filtered by gravity using a 20 cm water pressure; then pressure is imposed on the system to flow through the 50 nm filter.

The mineral composition of the water samples from the first campaigns was determined by XRD using centrifugation at 1800 g during 20 min. This allows the deposition of the $> 1 \mu\text{m}$ fraction. For further campaigns, we used a continuous ultracentrifuge (Sharpless T1) at 13'000 g. We obtained classes of the following calculated sizes: 0.2-0.4, 0.4-0.65, 0.65-1.3 and 1.3-5 μm . The limit of the classes are approximate due to the uncertainty on density and to turbulent motion existing in the tube.

The analysis of individual particles was processed with a SEM-EDS (Jeol JSM-35). Particles from the Bied brook and the Noiraigue spring were recovered at 4 sampling dates (19.07, 26.07, 09.08 and 16.08.1995) onto Nuclepore polycarbonate filters (2 and 0.8 μm). Approximately 1000 particles were randomly chosen and analysed under identical conditions for Mg, Al, Si, P, K, Ca, Ti, Mn and Fe.

The bacteria flora was enumerated by using the following two techniques: (i) liquid cultures by serial dilution of samples in microtiter plates or incubation of filters on solid media and (ii) Epifluorescence using a photonic microscope with fluorescent light source.

4. Factors controlling particle size distribution (PSD)

A review of analysed PSD in natural media (ATTEIA & KOZEL 1997) showed that the amount of colloidal/particulate matter in Noiraigue Spring falls intermediate between deep groundwaters and large rivers. The peaks of the volume weighted distributions occur at fairly large sizes compared to any other groundwater.

More than 55 samples were analysed for the Noiraigue spring and 35 for the Bied brook. Each curve consists of more than 100 values before the data is treated and 18 values after class aggregation. In order to analyse the whole dataset modelling of the curves was necessary. Most of the PSD curves are composed of two parts. The break point is generally situated near 5 μm . The first part of the curve is best fitted by a model in which the number of particles is a power law of particle size, sometime called a Pareto distribution (LERMAN 1979).

$$\frac{dN}{d\phi} = a \cdot \phi^{-b}$$

where N is the particle number and ϕ the particle diameter, b is the slope and a the intercept.

The second part of the curve can be fitted by a Pareto law, or an exponential law.

$$\frac{dN}{d\phi} = a \cdot \exp(-b \cdot \phi)$$

The symbols have the same signification as above. The criterion of choice between the two curves was the mean square error.

In this paper, we deal only with the values of the model at specific sizes (0.5, 4 and 10 μm). These will be referred as $N_{0.5}$, N_4 and $N_{10\mu\text{m}}$. The values are given in number of particles/ml/ μm . The d_{max} parameter is the size, in μm , at which the model crosses the value of 10 particles/ml/ μm .

At Noiraigue, the most influential parameter on PSD curves is the effect of spring discharge on the shape of the second part of the curve. The d_{max} parameter increased with the square of the discharge, as shown in Fig. 1. However, some samples show higher d_{max} for the same value of discharge. These points were generally sampled during the steep rising of the hydrogram. Other environmental factors such as temperature or electrical conductivity seem to play an insignificant role on the parameters of the second part of the model.

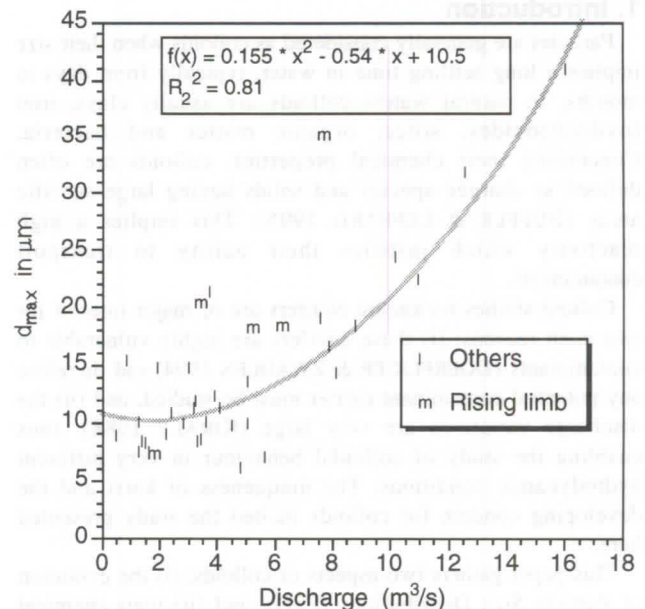

Rising limb: samples collected during the rising limb of storm hydrogram
Others: samples collected during other periods

Fig. 1: Relation between d_{max} parameter and discharge at Noiraigue.

At high flow, water is able to transport larger particles due to the high ratio of horizontal velocity to stokes settling velocity. But discharge appears to have a different effect during rise and recession period of a storm event. This effect may be interpreted as a resuspension phenomenon. Large particles should sediment in the aquifer during recession periods. When significant rainfall occurs, the water flux and velocity swiftly increase and generate turbulence in the previously quiet zones. This turbulence may resuspend the large particles, which can then remain in suspension and be transported if velocities are sufficient in the whole system. As the large particles are washed out, their content at the spring quickly decreases.

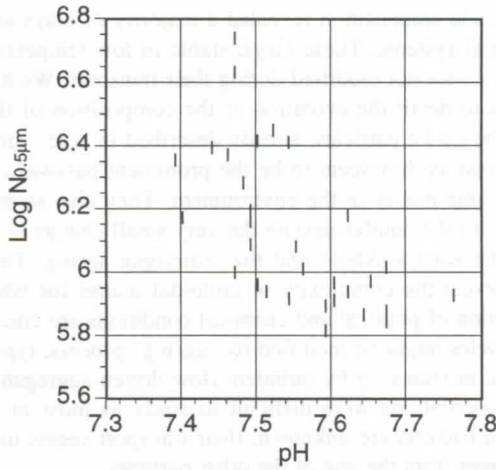

Fig. 2: Relation between pH of the Noiraigue water and number of small particles.

The number of small particles (i.e., the first part of the curve) is independent of discharge but clearly decreases with increasing pH (Fig. 2). Particle number is an order of magnitude higher at pH 7.4 than 7.8. This pH effect can be interpreted as a coagulation effect. In fact the aggregation properties of clays or other colloids is highly dependent on pH. When pH is close to the zero point of charge (zpc), the surface charge decreases, and colloids can form larger aggregates diminishing the number of small particles. However, it is difficult to predict the effect of this process on a PSD curve since no model of aggregation has been successfully applied to natural PSD.

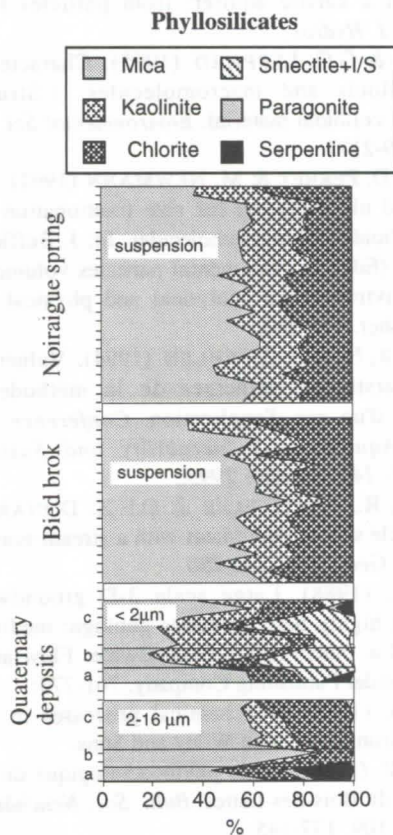

Fig. 3: Mineralogy of boreholes drilled on surface sediments (a: Molasse, b: Tills, c: Marls) and suspensions from Bied brok and Noiraigue spring (lines show different sampling campaigns). Phyllosilicates are presented in proportions of total phyllosilicate.

The role of environmental factors on the Bied brok PSD curves is more difficult to describe. The effect of discharge on each parameter seems to be negligible. The only dependence found is the effect of temperature on the number of small particles. This could be explained by the influence of temperature on the global biological activity and particularly on the bacterial growth. Again, data sampled during the steep rising of the hydrograph form a separate population with higher particle numbers for the same temperature.

5. Nature of transported particles

The suspensions from the Bied brok and the Noiraigue river contained mainly quartz, calcite and dolomite grain minerals and mica, chlorite and kaolinite phyllosilicates. Both locations show similar composition of the phyllosilicate fraction, i.e. ca. 50% of mica, ca. 25% of kaolinite and ca. 25% of chlorite, phyllosilicates also existing in the quaternary deposits. However smectite and mixed-layers, well represented in the deposits, are absent from the sampled waters (Fig. 3). Suspensions are also enriched in feldspars relative to deposits. The content of calcite relative to quartz is higher in the Noiraigue waters than in Bied ones.

On the size fractionated samples, the sedimented fraction contains only quartz, calcite, dolomite and sometime feldspars.

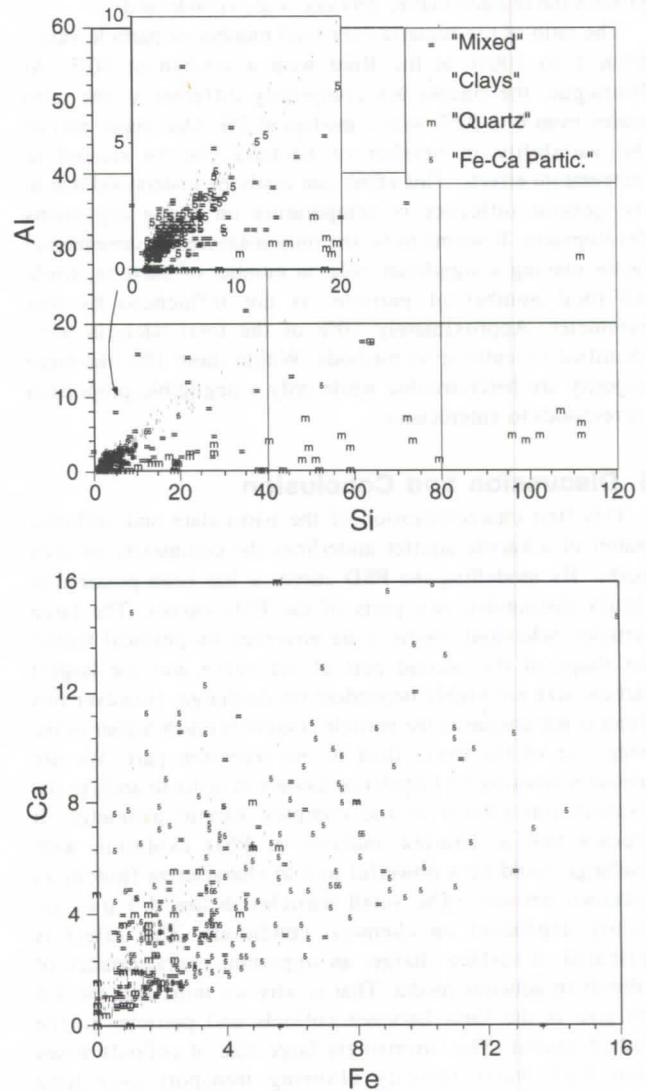

Fig. 4: SEM-EDS intensities (relative units) measured on particles from the Bied brok: a) Si and Al, b) Fe and Ca

Ultracentrifuged fractions show phyllosilicates, quartz, dolomite in some samples, and scarce and small peaks of feldspars. Quartz peaks decrease with decreasing size of particles, and dolomite peaks almost disappear down to ca. 0.65 μm . Mica, kaolinite and chlorite are not significantly differentiated by size, as opposed to mixed-layer clays and talc which appear only at small particle size. Mixed-layer clays were detected only after fractionation: they might have been hidden by larger particles on raw samples.

In the SEM-EDS analysis the main difference between Bied and Noiraigue are the Fe intensities being more than twice higher in the Bied brook. The use of Al and Si intensities allowed the differentiation of four groups of particles: Clays, Quartz, Fe-Ca particles, and mixed particles (Fig. 4). All Bied particles have the same range of Ca and Fe intensities and the same Ca/Fe ratio. Beside, if particles are differentiated according to campaign number, a clear Ca/Fe correlation appears independently of the particle types. At Noiraigue the particles present very small amounts of Fe and thus no correlation between Fe and Ca content has been established.

It has been established that the numerous Ca-Fe particles encountered at the Bied mainly consist of organic matter covered by Ca and Fe. It seems that these particles come from organic matter network existing in peats on which iron precipitates when the media becomes oxidizing. During this process the organic matter network is also condensed.

The ratio of the bacteria over total number of particle varies from 1 to 100% at the Bied with a median at 30%. At Noiraigue, the figures are completely different as the ratio varies from 0 to 22% with a median at 2%. One major part of the variability in number of bacteria can be related to temperature effects. This effect can easily be understood due to the general influence of temperature on living organisms development. It seems to be the only measured environmental factor playing a significant role on number of bacteria, while the total number of particles is not influenced by this parameter. Approximately 10% of the total bacteria were identified by cultivation methods. Within these 10% the large majority are heterotrophic while only a negligible proportion corresponds to enterococci.

6. Discussion and Conclusion

This first characterization of the particulate and colloidal matter of a karstic aquifer underlines the complexity of such media. By modelling the PSD curves it has been possible to clearly distinguish two parts of the PSD curves. The large particles behaviour seems to be governed by physical factor: the shape of the second part of the curve and the largest particle size are highly dependent on discharge. However this effect is not unique as the particle content is much higher in the steep rise of the event than in the recession part. We are presently working on turbulence models in order to analyse the resuspension effects in the complex karstic geometry. It appears that a detailed analysis of PSD evolution with discharge could be a powerful tool to characterize flow in an unknown network. The small particles, below 4-5 μm , are mainly dependent on chemical conditions. This effect is attributed to surface charge, an important characteristics of colloids in aqueous media. That is why we think that the 4-5 μm size is the limit between colloids and particles in the studied aquifer. The surprisingly large size of colloids arises from high water velocity allowing transport over long distances and turbulent flow enhancing the aggregation process.

The particle composition revealed a majority of clays as in many natural systems. These clays, stable in low temperature environments are not modified during their transport. We have few means to detail the evolution of the composition of their surface. The Ca-Fe particles, already described in lakes, are of major interest as they seem to be the prominent passways for Fe and organic matter in the environment. They also seem to be retained in the aquifer despite the very small change in pH between the Bied sinkhole and the Noiraigue spring. These particles reveal the complexity of colloidal matter for which the interaction of physical and chemical conditions are crucial. These particles might be modified by "ageing" process, typical of colloidal mixtures, or by turbulent flow driven aggregation. Bacterial populations were difficult to study as most of the enumerated bacteria are unknown, their transport seems to be quite different from the one of the other particles.

The role of colloids in biogeochemical cycles is evident for the elements such as Al, Si incorporated in clays, but, as determined above, also for Fe and organic matter. Beside, the importance of colloids in contaminant transport can be extrapolated from this study. Particle counting showed the large number of particles present in natural samples, and electron microscopy evidences the tremendous surface areas free for contaminant adsorption. However, we showed above that the particles were complex and often made of mixtures of several particle types. The main chemical colloidal characteristics, namely adsorption capacity and surface charge must therefore be determined directly on natural samples.

References

- ATTEIA, O. & R. KOZEL (1997). Particle size distributions in waters from a karstic aquifer: from particles to colloids. *Accepted by J. Hydrol.*
- BUFFLE, J. & G.G. LEPPARD (1995). Characterization of aquatic colloids and macromolecules. 1. Structure and behaviour of colloidal material. *Environmental Sci. and Tech.*, 29, n°9: 2169-2175.
- BUFFLE, J., D. PERRET & M. NEWMANN (1992). The use of filtration and ultrafiltration for size fractionation of aquatic particles, colloids and macromolecules. In: J. Buffle and H. P. van Leeuwen (Eds), *Environmental particles volume I. IUPAC Series on environmental analytical and physical chemistry*. Lewis Publisher. 171-230.
- DOERFLIGER, N. & F. ZWAHLEN (1994). Vulnérabilité des aquifères karstiques: principes de la méthode EPIK et présentation d'un cas d'application. *Conference on Karst-Fractured Aquifers - Vulnerability and Sustainability. Katowice, 11- 14 septembre 1995.*
- JANTSCHIK, R., F. NYFFELER & O.F.X. DONARD (1992). Marine particle size measurement with a stream-scanning laser system. *Mar. Geol.*, 106: 239-250.
- KIRALY, L. (1988). Large scale 3-D groundwater flow modelling in highly heterogeneous geologic medium. In: E. Custodio and a. others (Eds), *Groundwater Flow and Quality Modelling*. Reidel Publishing Company. 761-775:
- LERMAN, A. (1979). *Geochemical processes in water and sediment environments*. John Wiley and Sons.
- MATTHEY, Y. (1986). Etude phytosociologique du complexe de tourbières du Bois-des-Lattes. *Bull. Soc. Neuchâteloise Sci. Nat. (Suisse)*, 109: 137-145.
- MCDOWELL-BOYER, L.M., J.R. HUNT & N. SITAR (1986). Particle transport through porous media. *Water Resour. Res.*, 22: 1901-1921.

Temporal variations of spring water temperatures in relation to the extents of the heat transport modes occurring in the karstified lower Gypsum-Keuper aquifer (Karnian, southern Germany)

Jochen Bundschuh,

Technical University of Darmstadt, Institute of Geology, Schnittspahnstraße 9, 64287 Darmstadt, Germany
present address: University of Salta, Institute of Hydrogeology, INASLA, Buenos Aires 177, 4400 Salta, Argentina.

Abstract

The importance of different heat transport modes was studied by analysis of the temporal sequences of spring water temperatures in a karstic aquifer. For the aquifer with a horizontal groundwater flow and flow velocities of more than 100 m year^{-1} , model calculations indicate that horizontal heat transport in the aquifer occurs predominantly by convection. For vertical heat transport from the earth's surface, conduction and convection are implicated in varying degrees; in order to indicate these, the temporal series of the spring water temperatures were separated into their conductively and convectively components. Generally this can yield valuable information about the properties of thin surface-near aquifers. Thus, the quantification of a heat component transported vertically by convection into the aquifer can provide evidence of hydraulic conductivities as potential infiltration routes for contaminants.

Zusammenfassung

Die Bedeutung verschiedener Wärmetransportmechanismen wurde in einem verkarsteten Aquifer durch Zeitreihenanalyse von Quellwassertemperaturen untersucht. Für den Aquifer mit horizontaler Grundwasserströmung und Fließgeschwindigkeiten von über 100 m Jahr^{-1} , haben Modellrechnungen gezeigt, daß in dem Aquifer der horizontale Wärmetransport überwiegend konduktiv erfolgt. Am vertikalen Wärmetransport von der Erdoberfläche her, sind Konduktion und Konvektion zu verschiedenen Maßen beteiligt; um diese zu bestimmen, wurden die Zeitreihen der Quellwassertemperaturen in ihre konduktiv und konvektiv erzeugten Komponenten aufgetrennt. Generell erlaubt dies Hinweise auf Eigenschaften geringmächtiger oberflächennaher Aquifere; so kann die Quantifizierung einer konvektiven Vertikalkomponente Hinweise auf mögliche Infiltrationswege für Schadstoffe liefern.

1. Introduction

Climatic changes on the earth's surface, especially changes through time in temperature and precipitation, influence underground temperature in a complex manner by means of conductive, convective, and dispersive heat transport. In addition to those already mentioned, parameters and causes influencing heat transport (and also underground temperature) are as follows: depth-to-water table, thickness and articulation (hydraulic conductivity) of the layers overlying the aquifer, materially dependent parameters and parameter functions of aquifer components (heat conductivity, heat capacity, density, viscosity, etc.), groundwater recharge, geological, hydrogeological and hydrological data pertaining to the aquifer and its environment.

Input factors such as precipitation, the earth's surface temperature, etc. are known to be involved, as are too temporal series of groundwater temperatures as output factors. Unknown, however, is the extent to which the various heat transport modes are involved in overall heat transport from the earth's surface into the aquifer (thereby altering the latter's temperature). Such knowledge might provide important insights for solving hydrogeological questions.

Transfer of thermal energy in aquifers involves several, reciprocally linked transport mechanisms (HOLMANN 1976, IBELE 1963, JISCHA 1982, KAY & NEDDERMAN 1974, KNUDSEN & KATZ 1958). Conductive transport along an existent temperature gradient, is found both in the grain skeleton and in fluids. Heat transport through moving groundwater can be described by a convective and a dispersive term. In convective transport heat propagation in a fluid occurs with an average interstitial velocity. The transport mechanism of dispersion comprises all processes that can be attributed to the effective velocity deviating from the average interstitial velocity.

The various heat transport mechanisms dominate under different hydrogeological conditions (flow velocities, dispersivities, thermally open or closed system, etc.). Their role in overall heat transport was quantitatively determined by the author (Bundschuh, 1993). He found that for one-dimensional

heat propagation in a 10 m thick, horizontally percolated sand aquifer which was thermally insulated both above and below, and for average interstitial velocities of up to 1 m year^{-1} , only conduction is significantly implicated, while for more than 100 m year^{-1} convection accounts for 90 % of heat transport. For average interstitial velocities of over 10 m year^{-1} , the dispersive component is less than 10 % for a longitudinal dispersivity of 10 m. If the horizontally percolated aquifer is not thermally insulated above and below and restrained by impermeable layers, significant amounts of heat can be removed from or fed into the aquifer via these layers by means of vertically oriented conduction.

The importance of the different heat transport modes was studied by analysis and interpretation of the temporal sequences of spring water temperatures and other hydrogeological and hydrochemical parameters of a partially karsted gypsum aquifer in the Gäu region (southern Germany).

2. Field examples

Area description and basic investigations

Morphologically, the Gäu comprises the broad floodplain expanses, formed by mollusk-bearing limestone (*Muschelkalk*, mo), loam-keuper (*Lettenkeuper*, ku), and lower gypsum-Keuper (*Gipskeuper*, km₁) in the approaches to the southwestern Swabian Alb; while the younger gypsum-Keuper forms the rise to the Keuper mountains. The 18 m thick loam-Keuper (ku) consists of a series of water-retaining clay-marls and clefted, water-conducting sandstones and dolomites (spring discharge up to 3 l s^{-1}). The overlying, unleached 100-110 m thick gypsum-Keuper can be subdivided in terms of its hydrogeological properties. The lower part, which constitutes the principal groundwater conductor, is formed of 20 m thick main gypsum (*Grundgips*) layers, which consist to 60-65% of gypsum/anhydrite (spring discharge up to 50 l s^{-1}). In the upper part, which consists predominantly of relatively thin, clefted dolomite-marl banks and maximally 1 m thick gypsum/anhydrite deposits form groundwater conductors of lim-

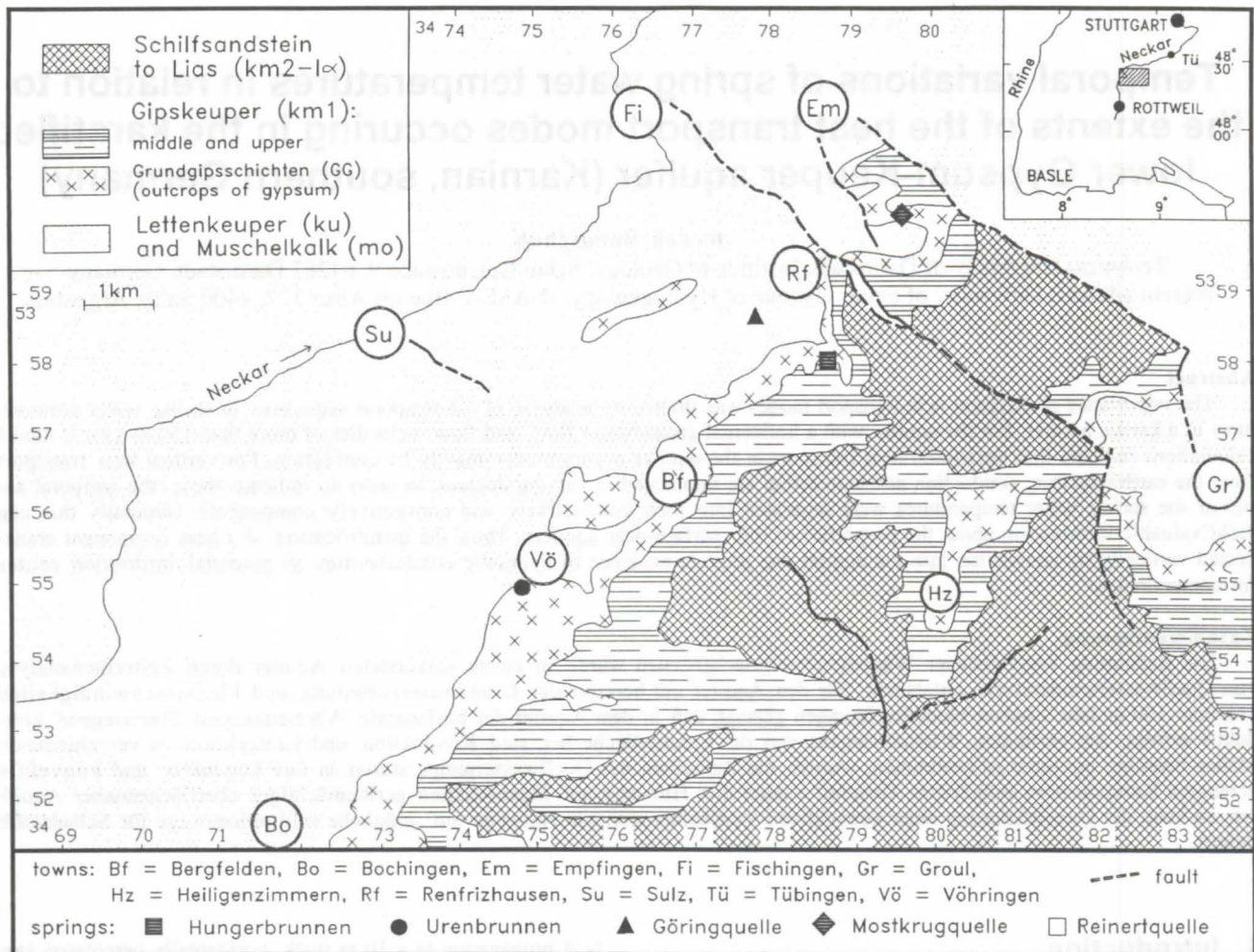

Fig 1: The area under investigation (Gäu between Fischen and Vöhringen): Geological layer organization, layer packing, hydrogeology, and location of springs used as examples.

ited significance (spring discharge up to 4 l s^{-1}).

Karst formation indicators (episodic springs, dry valleys, stream infiltration, sink holes, etc.) are predominantly restricted to the main gypsum levels (GGS) since the gypsum beds in higher levels only rarely attain a thickness of 1 m.

The discharge coefficient of the springs studied ranged from 0.2 to 0.6, i.e. at times significantly above those of the carbonate karst (mostly around 0.1). Springs whose GGS aquifers are not superposed by higher Keuper layers have discharge coefficients of 0.2, while values of 0.5 are obtained in corresponding cases of superposition of aquifers.

Semi-quantitative laboratory and field studies on the solubility of gypsum showed that mineralization of precipitated water occurs very rapidly (from within hours to a few days) upon penetration into the underground. Balanced behavior through time by electrical conductivity does not therefore necessarily suggest long residence times.

Determination of the outflux of geogenic sulfate yielded values between 220 and $360 \text{ t km}^{-2} \text{ year}^{-1}$, which corresponds to average leaching values for gypsum of 0.10 and $0.17 \text{ mm year}^{-1}$ respectively.

Spring water temperatures: an overview

From the temporal series of ground- and spring water temperatures - after correction for trends - the annual periodic component was isolated by applying Fourier analysis. This share predominantly reflects the slow process of conduction, through which periodic temperature changes on the earth's surface can be vertically transported down into the aquifer and after a time lag transferred to it in mitigated form. The remaining component comprises shorter-lived temperature changes that

are due to convectively vertically injected heat resulting from discrete precipitation events. The respective components obtained for the different field examples are graphically depicted in Fig. 2.

Applying as a differentiation criterion the changes in aquifer and spring water temperatures as a result of heat input from periodic climatic variations and short-lived precipitation events, for the springs studied in Gäu the following cases can be distinguished:

- Only short-lived discrete events with no discernible periodicity,
- neither discrete events nor periodicity discernible,
- periodic changes and discrete events occur,
- only periodic changes occur.

Each of these cases will be described in detail by a representative example (Fig. 2).

Example 1: Only discrete events occur

Example of this spring type: Urenbrunnen/Vöhringen.

Temperature graph: It does not contain any unambiguous periodic components. Changes have their origins in short-lived events, with only strong discrete events such as prolonged heavy precipitation or thawing episodes exercising a pronounced influence on the temperature of spring water. This produces temperature anomalies for the months of January through March, while - as a result of low groundwater recharge - a constant temperature progression is mostly only found during the rest of the year. Thus, if we resolve the spring water temperature into a Fourier series, we obtain for the periodic components an amplitude of 0.3 K (which is sur-

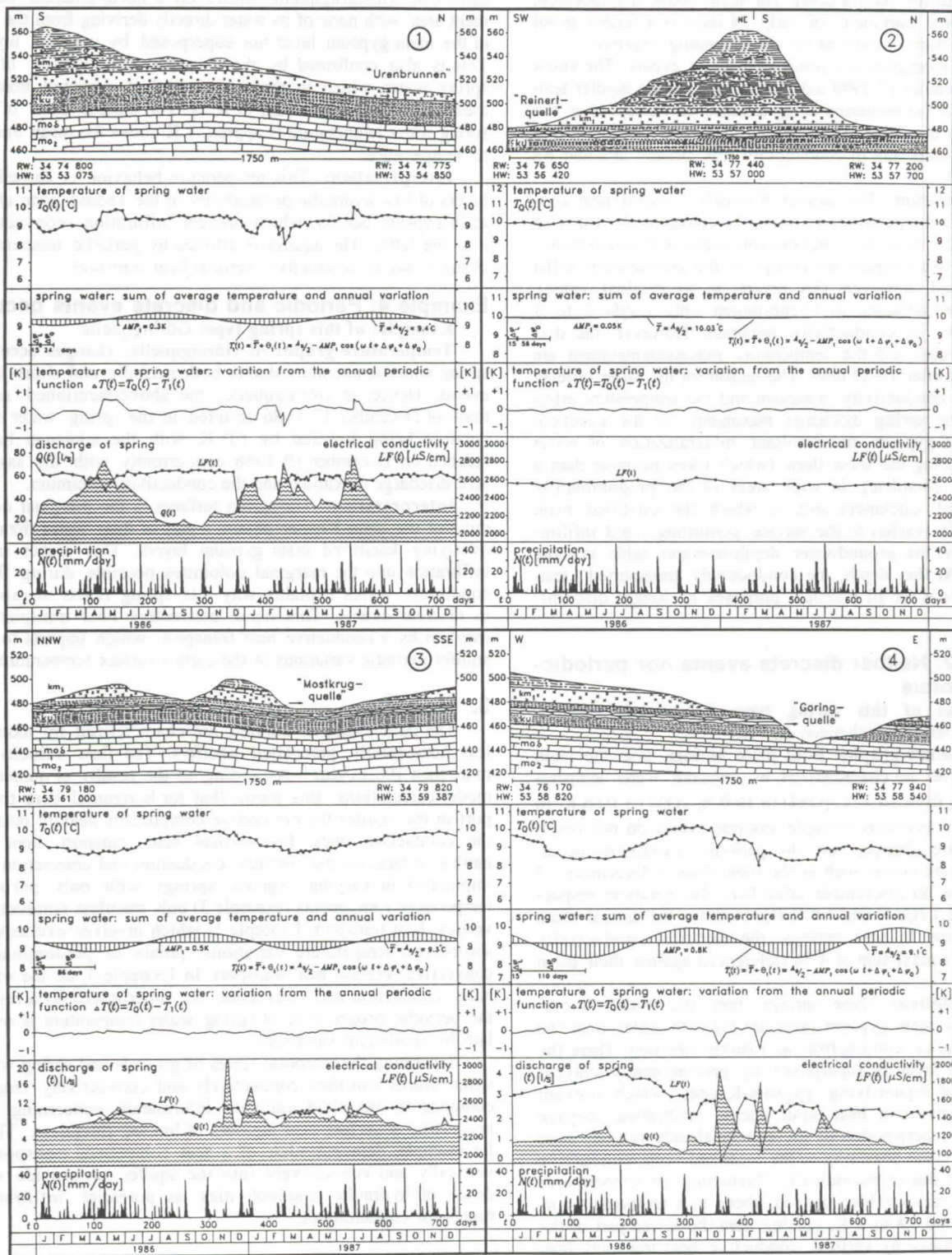

Fig. 2: Spring examples 1 to 4: • Cross-section through the main inflow area of the springs (above). The three diagrams set out below describe temporal temperature changes in the spring water: represented are: • the measurement series as discrete values of the actual temperature progression $T_0(t)$; • the primary (annual) harmonic θ_1 (periodic change with amplitude AMP_1) obtained by Fourier analysis from $T_0(t)$, representing (together with the mean annual temperature T) the measurement values of periodic progression $T_1(t)$ ($\Delta\phi_0$ indicates the phase difference between earth's surface and spring water temperature; $\Delta\phi_1$ the phase difference of the earth's surface temperature referred to January 1st); and • the deviations $\Delta T(t)$ of the measurement values from the periodic progression $T_1(t)$. These describe the temperature progression freed of periodic behavior, resulting from short-lived events. Both lowermost diagrams show • spring discharge $Q(t)$ and • electrical conductivity $LF(t)$ for spring water and for • local precipitation $N(t)$.

prisingly high for such a case). The scant phase displacement of this primary harmonic of only 24 days is a further proof that its minimum is induced by corresponding negative temperature anomalies as a result of discrete events. The snow thaw of December 17 1988 led to a sinking of the aquifer temperature, with the minimum being attained on Jauray 14 at the same time as the discharge maximum. It should be noted that the relevant minimum of conductivity was already attained on December 19.

Interpretation: This aquifer of mostly constant heat content (constant temperature) is primarily convectively fed with heat during the snow thaw and extreme summer thunderstorms, which leads to a temperature change in the groundwater (after a short period, however, this reverts to its original value). Groundwater surfacing in Urenbrunnen only needs 2 to 3 days to attain its conductivity minimum. However, the discharge maximum and the temperature maximum/minimum are only attained after 10-20 days. The reason for the large timelag between the conductivity minimum and the temperature minimum (and the spring discharge maximum) is the excellent solubility of gypsum and resultant mineralization of water infiltrated during the snow thaw (which takes no more than a few days to complete). In wide areas of the predominantly south-situated catchment area, in which the karstified main gypsum partly reaches to the surface, permitting rapid infiltration to occur, the groundwater depth-to-water table is more than 10 m. At this depth, the conductively transported temperature wave is for all practical purposes no longer discernible.

Example 2: Neither discrete events nor periodicity discernible

Examples of this spring type: Reinertquelle (Q31), Hungerbrunnen/Renfrizhausen (Q34).

Temperature graphs: Both these springs from the main gypsum aquifer are characterized by constant water temperatures ranging from 10.3 °C (Q34) to 10.0 °C (Q31) ± 0.06 K. In contrast to the previous example, discrete events do not result in temperature change, nor do periodic variations occur. Likewise severe events such as the snow thaw of December 17 1988 produce no discernible effect here. Temperatures respectively lie at 2.1 (Q34) and 1.8 K (Q31) above the annual mean air temperature. In both springs, the electrical conductivity fluctuated by a maximum of 4 % (referenced against their mean value).

Interpretation: These springs from the middle cross-section of the main gypsum layer are fed with water from the mountain side, i.e. coming from an easterly direction. There the main gypsum layer is superposed by predominantly clayey-marl layers of higher-lying gypsum-Keuper, which prevent any rapid, convective heat input due to infiltrating seepage water. Since superposition of the aquifer already reaches more than 10 m in close proximity to the localized seep, conductive heat transport due to periodically fluctuating air temperatures is no longer perceptible. Instead, there is a temperature increase of around 1.8 to 2 K, coming from the lower part of the aquifer and caused by vertical, conductive heat transport from the earth's interior. Under quasi-stationary conditions, this temperature increase corresponds to a mean aquifer superposition of 20 to 40 m. Neither convective nor conductive heat transport imposes temperature changes on the aquifer. Depending on depth, a heat flow emanating from the earth's interior leads to raised temperatures that produce spring temperatures of 10-10.5 °C.

Example 3: Only periodic changes

Example of this spring type: Mostkrugquelle.

Temperature graphs: It only exhibits periodic changes, not the effects of short-lived discrete events. Likewise a severe event like the snow thaw of December 17 1986 exerted no discernible influence on spring water temperature. This indi-

cates that Mostkrugquelle draws on a north-situated catchment area, with none of its water directly deriving from the area of the main gypsum layer not superposed by younger layers. This is also confirmed by the electrical conductivity of the spring water, which in the period studied deviated from its mean value by a maximum of 8 %. The annual mean of the spring water temperature is approx. 1 K above the mean annual air temperature.

Interpretation: This temperature behavior is caused by layers of low hydraulic permeability in the vadose zone of the main gypsum aquifer, which prevent infiltration (convection) into the latter. The aquifer is affected by periodic temperature changes due to conductive, vertical heat transport.

Example 4: Periodic and discrete events occur

Examples of this spring type: Göringquelle.

Temperature graph: At Göringquelle, changes occur in spring water temperature due to both periodic and short-lived events. Hence, at Göringquelle, the above-mentioned snow thaw of December 17 1986 resulted in the spring water temperature being lowered by 1.0 K, with the minimum being reached on December 19 1986 concurrently with the associated discharge maximum and the conductivity minimum.

Interpretation: The spring surfaces in the marginal dolomites of the loam-Keuper obtain a part of their water from the overlying karstified main gypsum layers. This makes rapid infiltration into the marginal dolomites possible during flood conditions, which explains why this spring reacts so rapidly to discrete events. This rapid, convective heat transport is overlain by a conductive heat transport, which imparts to the aquifer periodic variations in the earth's surface temperature.

3. Results

The field examples studied are characterized by more or less horizontally percolated aquifers. The flow velocity is more than 100 m year⁻¹. According to the results of numerical model calculations, this means that for horizontal heat transport in the aquifer the convective components heavily outstrip the conductive ones. For vertical heat transport from the earth's surface, on the contrary, conduction and convection are implicated in varying degrees. Springs with only periodic temperature components (example 3) only manifest conductive, vertical heat transport. Example 1, which involves exclusively short-lived temperature variations, points to predominantly convective, vertical heat transport. In Example 4, on the other hand, conduction and convection are superposed; as a result, the periodic progression of spring water temperature is overlain by short-term variations.

Separating the temporal series of ground- and spring water temperatures into their conductively and convectively created components can yield valuable information concerning the properties of surface-near aquifers of limited thickness. Thus, for example, demonstration of a heat component transported vertically and convectively into the aquifer can provide evidence of hydraulic conductivities as potential infiltration routes for contaminants.

4. Bibliography

- BUNDSCHUH, J. 1993. Modeling annual variations of spring and groundwater temperatures associated with shallow aquifer systems. *J. Hydrol.* 142: 427-444.
- HOLMAN, J. P. 1976. Heat transfer. McGraw-Hill Book Comp., New York.
- IBELE, W. (Ed) 1963. Modern developments in heat transfer. Academic Press, New York.
- JISCHA, M. 1982. Konvektiver Impuls-, Wärme- und Stoffaustausch. Vieweg Verlag; Braunschweig, Wiesbaden, 367 pp.
- KAY, J. M. & NEDDERMAN, R. M. 1974. An introduction to fluid mechanics and heat transfer. Cambridge University Press; Cambridge.
- KNUDSEN, J. G. & KATZ, D. L. 1958. Fluid dynamics and heat transfer. McGraw-Hill Book Comp., New York.

Results of a study about tracing tests transfer functions variability in karst environment.

par Nathalie Doerfliger

Centre d'Hydrogéologie, Université de Neuchâtel, 11 rue E-Argand, 2007 Neuchâtel, Switzerland.

Abstract

Artificial tracing tests are often used to simulate migration of a point-source contaminant under various hydrological conditions in karst hydrogeological impact assessment or to define groundwater protection zones. Due to economic reasons, it is rather difficult to carry out adequate tracing tests to determine what are the possible recovery curves over range of discharges at the outlet, are the tracer test results representative of the spring watercatchment being protected? Our objective was to characterize the tracing-systems in a karst environment by a mean transfer function; such transfer function may be used to predict the breakthrough curve of a point-source contaminant taking into account an error factor. A Jura mean transfer function with + and - 95% interval confidence functions can be established and differentiated from the Alps mean transfer function. The use of this transfer function to predict the response of a point-source contaminant requires considerations of water catchment size, thickness or the aquifer and discharge at the outlet. The results of this variability analysis confirm that the transfer functions by themselves may not be used to protect the whole karst spring water catchment, as this one is affected by the heterogeneity of the physical parameters. At the scale of a water catchment, transfer functions are not the major tool to protect the groundwater. But with a multiattribute approach of vulnerability mapping, transfer functions contribute to the development of groundwater protection strategy.

Résumé

Les essais de traçage sont souvent utilisés dans le cadre d'étude d'impact ou de délimitation de zones de protection afin de simuler la migration d'une contamination ponctuelle et ceci pour des conditions hydrologiques différentes. Pour des questions économiques, il n'est pas possible d'effectuer le nombre d'essais de traçage suffisant pour déterminer la variation des courbes de restitution pour des conditions de débit différentes et connaître la courbe de restitution caractéristique de la source du bassin à protéger. Notre objectif est ainsi de caractériser les systèmes-traçages en milieu karstique par une fonction de transfert moyenne; une telle fonction peut être utilisée pour prédire la courbe de restitution d'un contaminant d'une source ponctuelle prenant en considération un facteur d'erreur.

1. Introduction

Artificial tracing tests are often used to simulate migration of a point-source contaminant under various hydrological conditions in karst hydrogeological impact assessment or to define groundwater protection zones. Due to economic reasons, it is rather difficult to carry out adequate tracing tests to determine what are the possible recovery curves over range of discharge at the outlet. Our objective was to characterize the tracing-systems in a karst environment by a mean transfer function. If transfer functions can be readily obtained from input-response models, can they be used to predict contamination migration for part or all of karst water catchments? Can we differentiate a transfer function developed for tracer tests in the Alps from those derived from tests in the Jura? Do hydrological conditions affect the transfer functions?

To study the variability of transfer functions, the results of 96 tracer experiments have been used. 14 were done in the Swiss Alps, 12 in the Folded Jura and 70 in the Tabular Jura (DOERFLIGER, 1996).

2. Methodology

Interpreting tracing tests in terms of transfer functions is based on having an input-response conceptual model. The real system, the karst aquifer or the tracing system, is a closed box with an entrance and an exit. The internal structure is not determined as in a deterministic model.

Transfer functions can be obtained from tracer breakthrough curves and a black-box input-response model. It can also be directly obtained, without any mathematical treatment, from a breakthrough curve if 1) the tracer input is instantaneous, simulating a Dirac and 2) there is a continuous

record of the discharge at the sampled spring. When these conditions exist or are assumed to be true, the normalized breakthrough curve is a transfer function referred to a RTD (Residence Time Distribution).

In practice, however, instantaneous injection of tracers is not possible for several technical reasons. Consequently, the directly observed response of an injection at the outlet does not correspond to the impulse response. In that case, the impulse response has to be obtained by a mathematical "treatments" referred as deconvolution.

Input-response model : deconvolution operator

Input-response model or black-box model permits analysis of the karst system or sub-systems, the tracing-system. Considering a linear and steady-state tracing-system, even if in the real world, hydrogeological systems do not only response in a linear manner and their behaviour is not consistent in time with varying changes, for example in flow rates, transfer functions are obtained using a black-box model of deconvolution (DZIKOWSKI, 1992; GUIZERIX, 1988). The output function is deconvoluted by the input function; transfer function is calculated using the numerical code DYEBOX, a global mass transport FORTRAN 77 code (KIRALY & ROSSIER, 1992).

The discretisation of the deconvolution can be written as follows:

$$I(j) = \frac{1}{E(0)} \left[\frac{S(j)}{\Delta t} - \sum_{k=1}^j I(j-k) E(k) \right] \quad (1)$$

with j from 0 to N ; k a variable different than 0; ΔT is the chosen discretisation time step.

Several types of transfer functions (figure 1) can be described:

- the **impulse response** corresponds to the system responding to an impulse with Dirac conditions. The resultant unit response is independent of the injection duration.

- the **normalized response** is the system responding to a step function (or Heaviside function). It is the results of the convolution of the impulse response with a step function. This type of response is used in order to compare transfer functions to each other. In this situation, the normalized response is equivalent to a statistical distribution function and the derived normalized response directly defines, the impulse response. For example, the time corresponding to the 0.5 percentile is the time at which 50% of the tracer has passed through the system (figure 2).

- the **reference response** (KIRÁLY & ROSSIER, 1992) is equal to the system responding to a "reference impulse" which has been or can be characterised with an arbitrary duration and shape. The reference response corresponds to the tracer travel time (RTD) of a tracing tests. This response is opposite to an impulse response, in that it includes the duration to the input.

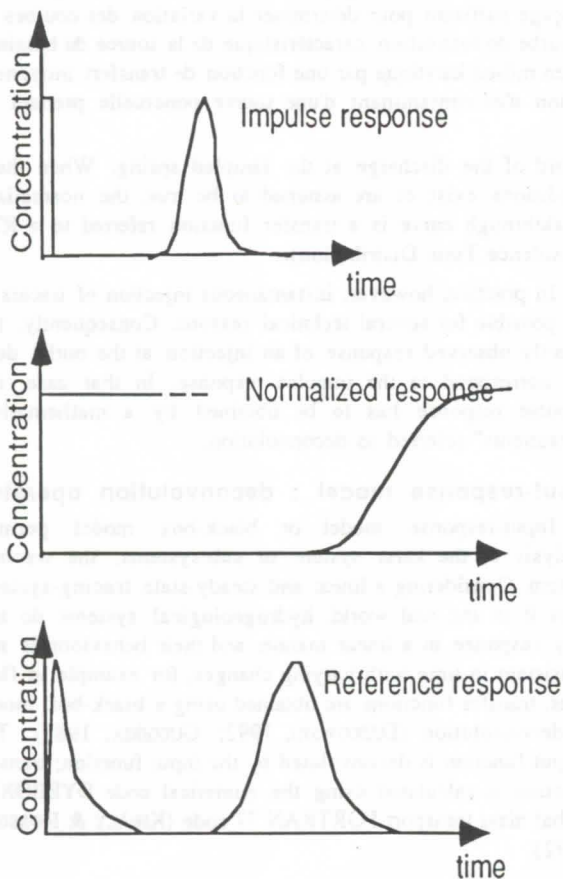

Figure 1: Various types of transfer functions: response of a system in relation to the type of input function

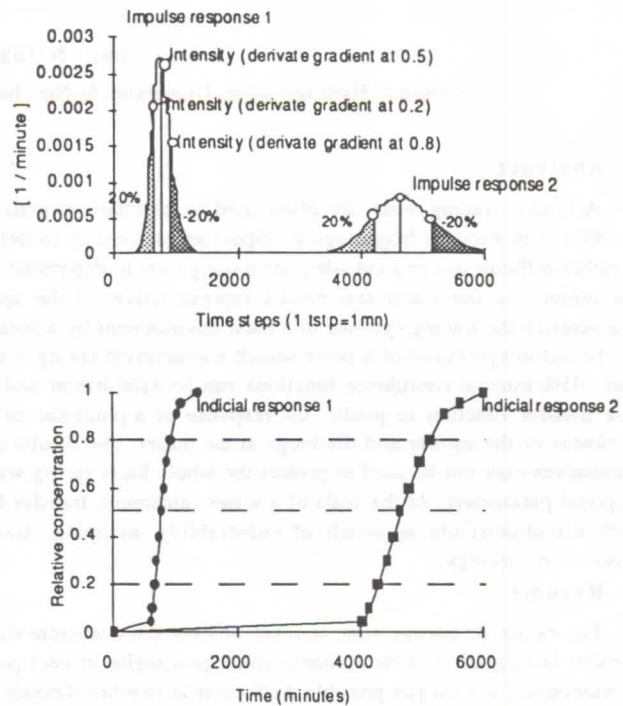

Figure 2: Relation between the gradient at percentiles 0.2, 0.5 and 0.8 of the normalized response and the corresponding intensity on the impulse response.

Deconvolution procedure for tracing tests

After calculating the recovery percentage of the tracer, interpretation of tracing experiments using the numerical code DYEBOX was done as follows procedure:

1. Smooth the output function if needed. The output function is determined either in mass flux units versus time, or in concentration units versus time.
2. Discretize, using the smallest possible constant time step. The choice of the time step is determined by the DYEBOX code, as the impulse response file cannot exceed 9600 rows.
3. Calculate the input function in relation to the recovered mass and the injection duration, according a simple right triangle shape. The input function is given in the similar unit as the output function.
4. Deconvolute with the code DYEBOX to determine the impulse response.
5. If needed, according to the quality of the obtained impulse response, conduct additional smoothing of the response or redraft it to remove to reduce the irregularities.
6. Verify the area under the impulse response function. (should be an unit function).
7. Convolute the impulse response with a step function to obtain a normalized response.
8. Characterize the normalized response using gradient values at the defined and specific percentiles of 0.2, 0.5 and 0.8.

Variance analysis

A variance analysis was carried out on the modal velocity and the 0.5 percentile gradient to compare the following conditions pertinent to each tracer test: geological setting, hydrodynamic conditions, nature of injection point, catchment size, the tracer distance and the outlet discharge. These conditions were compared to determine if their mean values (gradient at 0.5 and modal velocity) were significantly different.

A single factor variance analysis (ANOVA) was carried out on each group to determine if the categories of each condition influenced the transfer functions.

Multiple factor variance analysis (MANOVA) was also carried out: in these cases, two or more variations in each of the tests conditions were simultaneously tested to determine if either cause significant differences between treated parameters means. Each parameter is assumed to have a normal distribution around its mean; all parameters have the same variance. This analysis allows calculation of a whole-model test considering the experimental values and the predicted ones and taking into consideration influences of each considered group. The significant difference is related to the results of the effect test: a probability $> F$ equal to 0.05 or lower than 0.05; this value is the significance level α .

3. Transfer functions variability

Results of the single factor variance analysis are summarised in the table 1.

There is no highly significant difference among any of the conditions and their categories for the normalized 0.5 percentile variance analysis. For other relationships, about half of the differences are moderate and the other half of low significance. The low significance is related principally to geological setting, hydrological conditions and injection point conditions, where as moderate significance characterizes the catchment size, tracer distance and discharge rate conditions.

The hydrological conditions provoke no major difference within each class of the geological context, contrary to the low degree difference among all the tracer tests between base flow conditions and rising limb conditions.

Generally, the gradient at 0.5 percentile which represents the mean values, for significant class of considered parameters, varies between 65 with a slope of 0.46 to 88.4 degrees, with a slope of 0.028. The slope at the percentile is calculated as the tangent of β , where $\beta = 90^\circ - \text{gradient}$.

Grad 0.5		PARAMETERS																							
		Geological context			Hydrological conditions			Injection nature				Surface of wc basin			Tracing distance (m)			Discharge (V s)							
		ALPS	FOLDED JURA	TABULAR JURA	BASE FLOW	RSNG LIMB	FALLING LIMB	Karstic network	Swallowhole	Borehole	Artificial hole	Surface	lower 5 and 5km2	5 - 15 km2	upper 75 km2	lower 100 m	100 - 1000m	1000-3000m	upper 3000m	100 V s	500 V s	1000 V s	5000 V s	10000 V s	50000 V s
All tracing tests (96)	X			X	X	O	O	O	O	X	X	X	X	X	X	X	O	XX	O	O	O	O	O	X	X
	76.5	82.4	80.9	81	76					76.2	83.1	83.5	76.4	83.5	88.4	82.8	78.1							82.7	73
	0.24	0.13	0.16	0.16	0.25					0.24	0.12	0.11	0.24	0.11	0.03	0.12	0.21							0.13	0.3
Jura s.l. (82)	/	O	O	O	O	O		X	X	X	X	XX	X	XX	XX	XX	O	XX	O	O	O	O	O	X	X
								83.5	80.7	76.2	83.8	84	76.3	83.5	88.4	82.8	77.8	0.21						87.5	70
								0.11	0.16	0.24	0.1	0.1	0.24	0.11	0.03	0.12	0.12	0.21	0.12					0.04	0.4
Alps (14)				O	O	O	O	O	O	O	O	O	O	O	/	/	XX	O	XX	O	O	O	O	O	O
																	65								
																	0.46								
																	76.2	0.24							
																	79.2	0.2							
Folded Jura (12)				O	/	O	/	XX	/	/	XX	/	XX	XX	O	O	O	O	O	O	O	O	XX	XX	XX
								83.5			70		70	83.5									81.7	73	70
								0.11			0.36		0.36	0.11									0.15	0.04	0.4
Tabular Jura (70)				O	O	O	/	/	/	X	X	X	X	X	/	/	X	X	X	X	X	O	/	/	/
								80.7	76.2	84.75		84	76.5				88.4	83.6	77.9	76.1					
								0.16	0.24	0.09		0.1	0.24				0.03	0.11	0.21	0.25					

Legend: XXX significantly different . Require upper or equal to 0.75
 XX significantly different . Require upper or equal to 0.25 and lower than 0.75
 X significantly different . Require equal to 0.1 and lower than 0.25
 — group of parameters different from another
 [] difference between this and that
 O no significant difference
 83.5 mean value of the gradient α at the percentile 0.5; * mean value for 3000 to 5000 m; ** mean value for upper 5000 m distance
 8.4 mean value of the tang β when b is equal to 90° - gradient α . When gradient α tends to 90°, tang β tends to 0. When gradient α tends to 45°, tang β tends to 1
 / no available data

Table 1: Significant and non significant differences of gradient means at 0.5 percentiles.

Among all tracer tests, a low significant difference in the geological context and in the hydrological conditions parameters appears. The mean characteristic values (modal velocity and gradients) of the transfer functions of tracer experiments permit to distinguish the Alps transfer functions from the Jura transfer functions. The mean transfer function of the Tabular Jura is not significantly different than for the Folded Jura (figure 3).

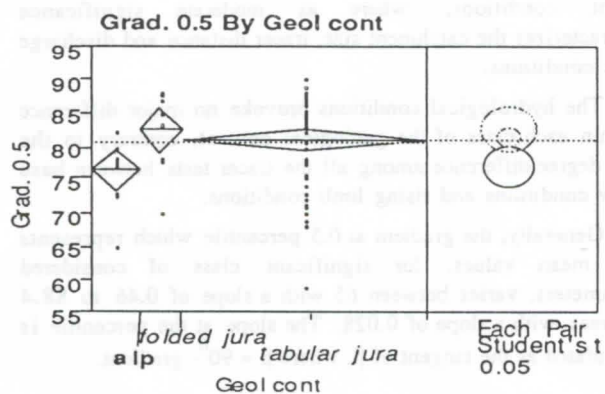

Figure 3: Variance analysis of the geological context for the 0.5 percentile gradient.

Source	Sum of squares	Mean square	F ratio
Model	279.19	139.6	3.77
Error	3443.74	37	

Prob>F
0.0267

For the hydrological conditions, the base flow mean transfer function differs from both the falling limb (gradient) or the rising limb (modal velocity). The rising limb (gradient), the falling limb (modal velocity) transfer functions are rather similar to the base flow mean transfer function. The difference between base flow and rising limb is not significant (Prob > F higher than 0.05).

In the Alps, tracer distance characterizes transfer functions. Other conditions are important to classify the characteristic modal velocity of tracer tests. Major differences result from changes of injection point. The injection point, tracer distance and catchment size are the only conditions whose classes cause differences in transfer functions characteristics.

In the Jura, the injection point plays an important role in characterizing transfer functions. In the Folded Jura, surface tracer test transfer functions are different from those in swallowholes. In the Tabular Jura, the main difference is between tracer tests carried out into boreholes and artificial holes and those with a direct sprinkling onto the surface. Transfer functions are influenced by the catchment size in the Tabular Jura. This influence is directly linked to the compounds of the tracer system and mainly to the ratio of the unsaturated to saturated subsystem. Tracer distance is therefore also significant in the Tabular Jura and is also related to the tracer system composition. Finally, discharge is significant in both the Folded and the Tabular Jura when there is no major difference in hydrological conditions.

4. Mean transfer function

From transfer functions variance analysis, a mean transfer function and a corresponding "95% confidence intervals"

function can be determined for the Jura and the Alps geological settings (figure 4).

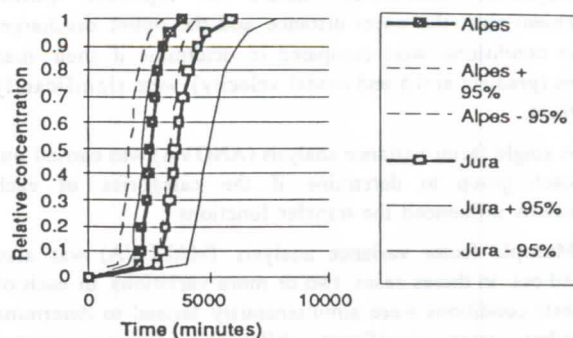

Figure 4: Calculated mean transfer functions for the Alps and the Jura with the 95% interval of confidence.

Within the Alps context and in the Jura context, where significant differences in the variance analysis appeared, mean transfer functions can be calculated. This is true for the 5000m and 10'000m tracer distance parameters in the Alps, for the injection point, the catchment size and the tracer system hydraulic conductivity in the Tabular Jura.

5. Conclusion and prospects

Variations in transfer functions can be distinct. On the economic purpose, we would like to determine mean transfer functions of a water catchment that is identified by some parameters such as its size, its mean transit distance, the thickness of the aquifer, the nature of the injection point, the discharge rate range,... But such functions do not exist! No significant difference of the considered parameters is relevant. Nevertheless, mean transfer functions from tracing tests corresponding to a given geological context or to a given injection point can be differentiated with significance.

The variability of the transfer functions within a water catchment is important and depends principally on the injection point, and to the proximity of the injection point to the karstic network.

At the scale of a karst water catchment, tracing tests are not the single tool used to protect groundwater; a multiattribute approach of vulnerability mapping may be considered as well.

References

- DOERFLIGER N. 1996. Advances in karst groundwater protection strategy using tracing tests analysis and multiattribute vulnerability mapping (EPIK method). Thesis, University Neuchâtel, Switzerland, 225pp.
- DZIKOWSKI M. 1992. L'analyse des systèmes-traçages à débit variable et volume constant. Possibilités d'application en milieu karstique. Thèse, Université des Sciences et technologies de Lille, février 1992, 182pp.
- GUIZERIX J. 1988. A geometrical interpretation of tracer experiments in non steady (flow, volume) systems. 4th conference on Radioisotope Application and Radiation Processing in Industry. Leipzig-G.D.R., sept. 1988.
- KIRALY L. & ROSSIER Y. 1992. Interprétation quantitative des essais de traçage dans les aquifères karstiques. Rapport interne du CHYN, pour le SHGN/OFEFP.

Evolution piézométrique et qualitative d'un aquifère carbonaté soumis à un fort pompage de longue durée : exemple du graben de Pinchinade (Mouans-Sartoux, 06)

par Yves Guglielmi**, Christian Mangan*, Jacques Mudry** & Anne Reynaud**

*Hydrogéologue conseil, 1 Bd Carabacel, 06 000, Nice.

**Laboratoire de Géologie Structurale et Appliquée, place Leclerc, 25 000, Besançon

Abstract

Pinchinade hydrogeologic unit (1 km²) is a Jurassic calcareous graben lowered into Triassic dolomite, clay and gypsum. A long time pumping test in the graben lead to the study of the emptying of the aquifer and to the measurement of the impact of Triassic groundwaters, rich in sulfate. Specific yield has been calibrated from 950 000 m³ pumped (in a 3 years time) and it appears that the pumped volume exceeds recharge capacity of the aquifer from effective rainfall. This overexploitation causes a lowering of nitrate concentrations due to surface waters infiltration as well as an increase in sulfate concentrations due to Triassic waters.

Résumé

L'unité hydrogéologique de Pinchinade (1 km²) est constituée par un graben de calcaires jurassiques abaissés dans les formations de dolomies, argiles et gypses triasiques. Un pompage d'essai de longue durée pratiqué dans ce graben a permis d'étudier la vidange à long terme du réservoir jurassique et de mesurer son impact sur la réalimentation par les eaux riches en sulfates du réservoir triasique.

L'exhaure de 950 000 m³ (en 3 ans) permet d'apprécier le volume spécifique et de dire que le prélèvement excède les potentialités de réalimentation de l'aquifère par la pluie efficace. Cette surexploitation se traduit par une diminution de la composante nitratéée superficielle, en même temps qu'une augmentation des eaux sulfatées calciques profondes en provenance du Trias.

1. Introduction

La régie municipale des eaux de Mouans-Sartoux (Alpes-Maritimes, 06) exploite une petite structure aquifère constituée par un graben de calcaires jurassiques karstifiés emboîté dans des formations triasiques argileuses et gypsifères. Les études engagées successivement depuis 1990 permettent une évaluation du volume de la ressource en eau disponible, des limites du bassin versant d'alimentation et des conditions du renouvellement de cette ressource. En particulier, nous avons évalué le risque de provoquer un drainage depuis l'aquifère triasique qui se traduirait, à terme, par une augmentation des teneurs en sulfate des eaux. Les recherches reposent sur des essais de vidange prolongée (exhaure de 950 000 m³ en un peu plus de trois ans) à débit variable complétés par des suivis piézométriques et chimiques de la nappe. La corrélation du rabattement en fonction du volume pompé (COLLIGNON, 1986) est couplée à l'analyse des traceurs naturels de l'eau (MUDRY, 1987) pour estimer le risque de contamination triasique.

2. Contexte hydrogéologique

L'aquifère exploité se situe dans les calcaires bajociens et hettangiens ainsi que dans les marnocalcaires rhétiens à la base de la série jurassique de l'avant-pays provençal. Ces terrains reposent sur les marnes, gypses et dolomies du Keuper localement aquifères mais qui peuvent être considérées comme relativement imperméables à l'échelle régionale. La série présente un pendage général de 10-20°SE fortement perturbé par un réseau de failles normales d'âge oligocène, orientées selon trois directions principales : N0-160, N20-30 et N90. Cette fracturation délimite des zones de horsts et de grabens globalement subméridiennes. Dans ce contexte, le drainage souterrain de l'aquifère du Jurassique inférieur se fait dans son ensemble de l'est vers l'ouest et localement selon la direction subméridienne des structures (MANGAN, 1982). Ainsi, la station de pompage de Mouans-Sartoux se situe à la côte NGF 250 au droit dun graben de 150-250 m de large et de 2-2,5 km de long, le graben de Pinchinade, constitué de calcaires bajociens effondrés dans les formations rhétiennes (Figure 1 A et B). Le contact avec le Keuper a été reconnu par sondages à 120 m de profondeur (MANGAN, 1990 et 1994). Les bordures latérales du graben formées en surface par les calcaires rhétiens et en profondeur par les formations gypsifères du Keuper contiennent des nappes d'eau souterraines en communication avec celle du graben. Des piézomètres installés dans le Rhétien montrent en effet un rabattement de la nappe lié au pompage dans le graben. Ces données nous conduisent à prendre en compte un impluvium d'alimentation d'environ 1 Km² nettement plus large que la surface même du graben (0,2 Km²) (Figure 1A). En raison de la lithologie marno-calcaire du réservoir Rhétien, les transmissivités sont plus faibles que dans le réservoir calcaire jurassique du graben. Le grand volume de ce réservoir latéral favorise en revanche l'emmagasinement des eaux souterraines.

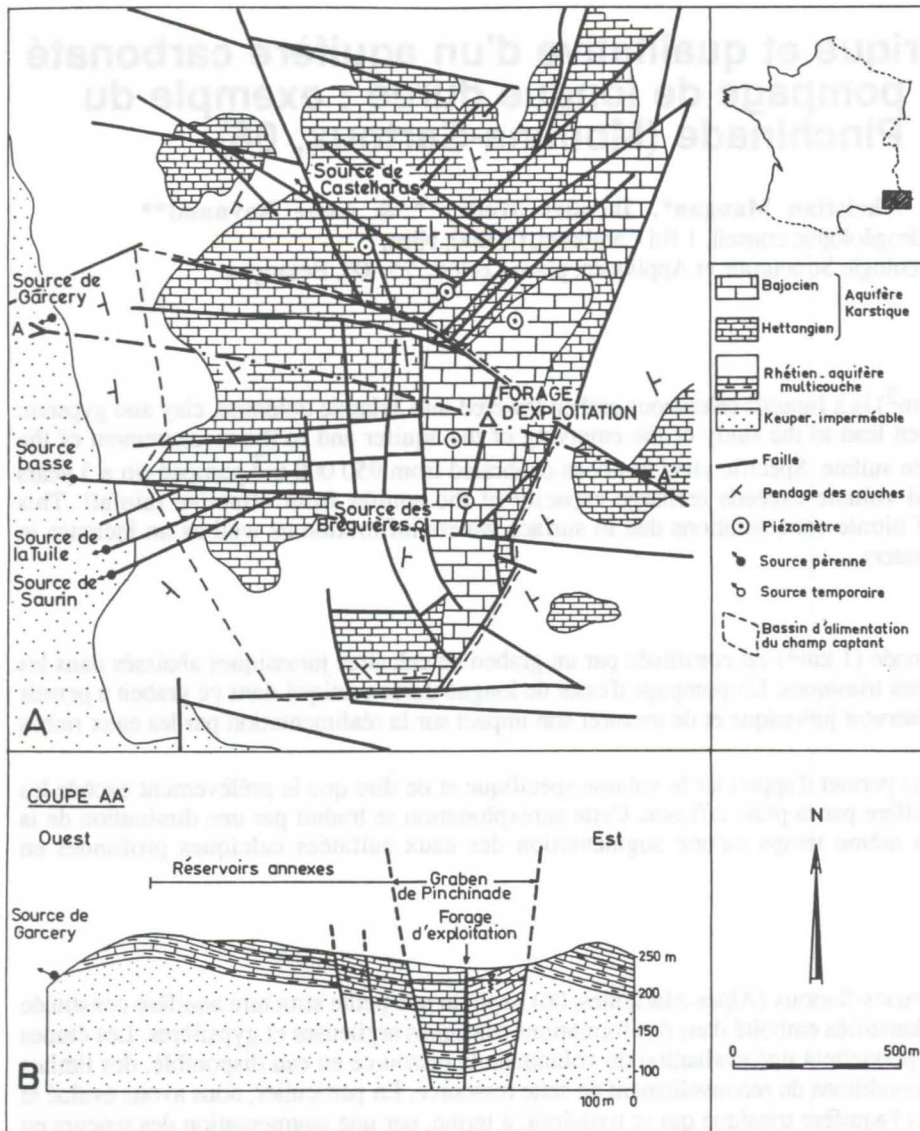

3. Réponse hydrodynamique à l'exploitation du karst

L'évolution du rabattement de la nappe dans le graben est réglée par l'historique des pompages et par les recharges successives de la pluie efficace et des aquifères bordiers (Figure 2). Après une série d'essais préliminaires (jusqu'à début mars 1994) marquée par des pompages à débit variable induisant des variations journalières importantes du rabattement, l'aquifère est testé à un débit plus régulier de 30 à 35 m³/h. Récemment (mai 1995), un deuxième forage est mis en action pour tester la nappe à un débit supérieur, de l'ordre de 60 m³/h. Le débit alors pompé dans les deux puits induit une augmentation de rabattement de l'ordre de 15-20 m. Mis à part les effets liés à l'historique des essais de nappe, la courbe rabattement en fonction du volume pompé montre des abaissements plus ou moins rapides en période de vidange du graben et des remontées en période de recharge par les pluies efficaces et les aquifères bordiers. A long terme, il apparaît cependant une tendance à l'augmentation du rabattement de la nappe de 30 m en début d'exploitation (09/1993) jusqu'à la valeur actuelle de 50 m (08/1996).

Pendant les périodes d'étiage, le rabattement évolue linéairement en fonction du volume pompé. Le volume spécifique (volume pompé par mètre de rabattement) est ainsi estimé à 3245 m³/m (Figure 2). Par la suite, il apparaît que lorsque cette relation linéaire ne se vérifie pas en étiage (juin à août 1994 par ex.), cela révèle l'importance des apports souterrains depuis les bordures du graben. La recharge par les pluies efficaces est forte d'octobre à avril où elle induit une remontée de la nappe, et faible le reste de l'année où elle perturbe peu la descente de la nappe liée au pompage.

Le volume moyen annuel de la réserve renouvelable de l'aquifère ainsi estimé à 2,5-2,75 10⁵ m³ (pour une réserve permanente exploitable de 2 à 2,5 10⁵ m³) apparaît donc inférieur au volume moyen annuel pompé de 2,8 10⁵ m³.

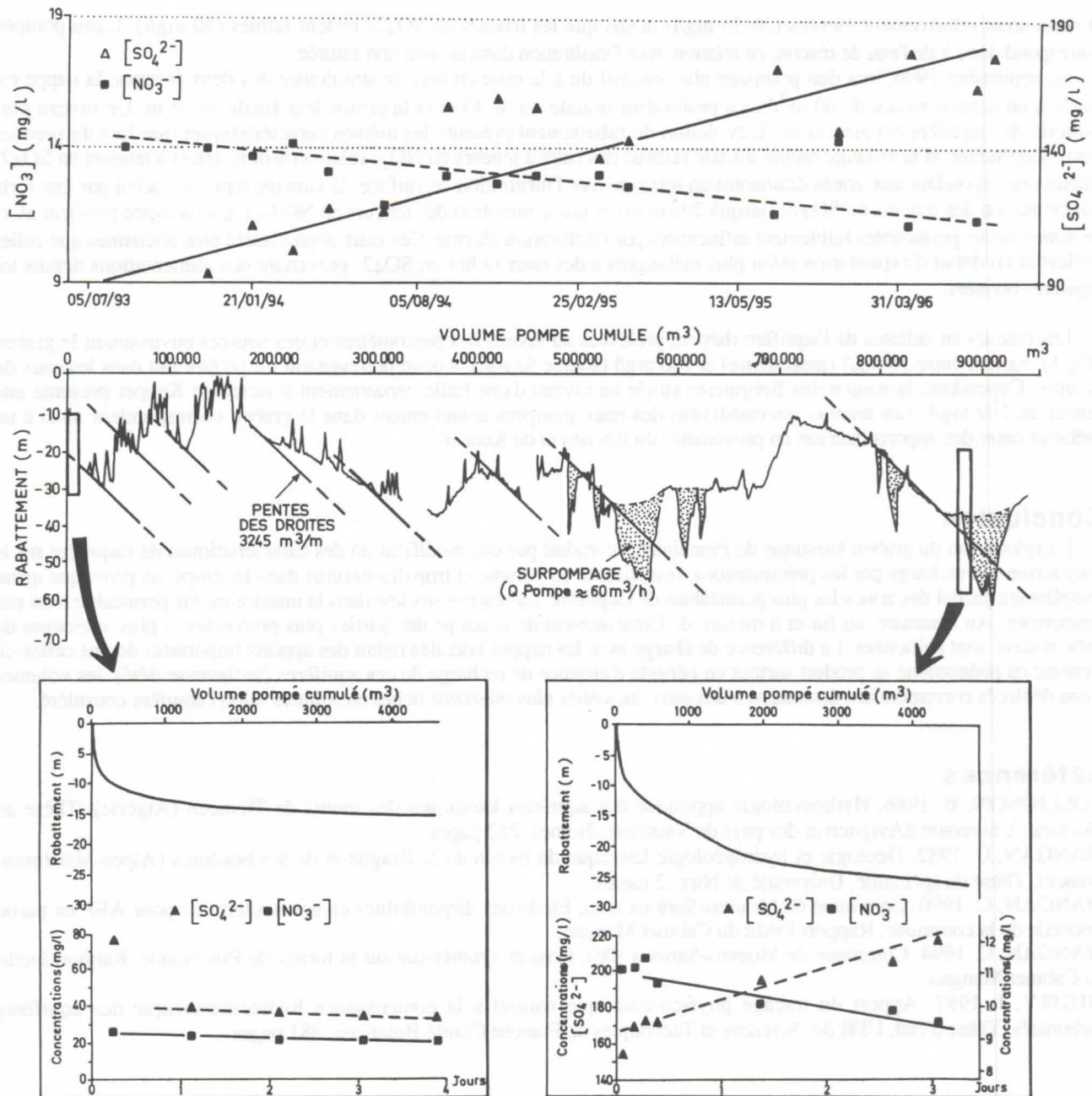

Figure 2 : Evolution des teneurs en sulfates et nitrates des eaux comparée au rabattement de la nappe en fonction du volume pompé depuis la mise en exploitation (en encadré, teneurs en nitrates et en sulfates des eaux comparées au rabattement pour deux périodes d'exploitation de la nappe).

4. Effet du pompage sur la chimie des eaux

Sur toute la période d'essai, l'évolution de la chimie des eaux se marque par une opposition nette entre la diminution progressive des teneurs en nitrates (élément marqueur des eaux d'infiltration), depuis une valeur de 19,4 mg/l jusqu'à 12,1 mg/l, et l'augmentation des teneurs en ions SO_4^{2-} (élément acquis dans le réservoir) de 32 mg/l jusqu'à 194 mg/l (Figure 2). Cette évolution régulière se corrèle mal avec les remontées piézométriques liées à la recharge par les pluies efficaces et traduit plutôt une modification à long terme de la chimie de l'aquifère.

Un suivi chimique plus précis comprenant des prélèvements effectués tous les jours permet de comparer deux époques d'exploitation sur des durées semblables de 3-4 jours, mais pour des états hydrodynamiques différents (Figure 2 encadrés).

En mai 1993, lors de l'essai de pompage précédent la mise en service du puits définitif, la nappe est testée à un débit constant de 49 m^3/h pour un rabattement final de 14 m. Après un abaissement rapide dans les premières heures du pompage correspondant à la vidange des zones les plus drainantes du réservoir, la vitesse de rabattement ralentit traduisant la vidange des zones moins drainantes. La chimie des eaux évolue peu dans le temps. Les teneurs en NO_3^- varient selon l'infiltration

et demeurent relativement élevées (20-25 mg/l) tandis que les teneurs en SO_4^{2-} restent faibles (30 mg/l). L'eau pompée correspond donc à de l'eau de réserve en relation avec l'infiltration dans la zone non saturée ;

En septembre 1996, lors d'un pompage plus intensif dû à la mise en service simultanée des deux forages, la nappe est testée à un débit constant de $60 \text{ m}^3/\text{h}$. La profondeur initiale est de 43 m et la profondeur finale de 75 m. Un niveau plus profond de l'aquifère est ainsi testé. L'évolution du rabattement présente les mêmes caractéristiques que lors du premier essai. Cependant, si la vidange rapide initiale restitue des eaux à teneurs en NO_3^- relativement fortes et à teneurs en SO_4^{2-} faibles correspondant aux zones drainantes en relation avec l'infiltration de surface, la vidange lente se traduit par une forte augmentation des teneurs en SO_4^{2-} (jusqu'à 205 mg/l) et une diminution des teneurs en NO_3^- . L'eau pompée provient alors de zones moins perméables faiblement influencées par l'infiltration récente. Ces eaux apparaissent plus anciennes que celles prélevées en début d'exploitation et/ou plus mélangées à des eaux riches en SO_4^{2-} provenant des alimentations depuis les aquifères bordiers.

Les teneurs en sulfates de l'aquifère rhétien, prélevées au niveau des piézomètres et des sources environnant le graben (Fig.1), varient entre 30 mg/l (piézomètre) et 100 mg/l (source Saurin). Aucun prélèvement n'a pu être fait dans les eaux du Keuper. Cependant, la source des Bréguières située au niveau d'une faille certainement injectée de Keuper présente une teneur de 199 mg/l. Les teneurs intermédiaires des eaux pompées actuellement dans le graben correspondent ainsi à un mélange entre des apports latéraux en provenance du Rhétien et du Keuper.

Conclusion

L'exploitation du graben karstique de Pinchinade se traduit par une modification des caractéristiques de l'aquifère sur le long terme. La recharge par les précipitations, insuffisante en volume et trop discontinue dans le temps, ne provoque qu'un remplissage partiel des zones les plus perméables de l'aquifère. La réserve stockée dans la matrice moins perméable n'est pas renouvelée. Au contraire, au fur et à mesure de l'abaissement de la nappe des parties plus profondes et plus anciennes de cette réserve sont sollicitées. La différence de charge avec les nappes latérales induit des apports importants depuis celles-ci. Comme ce phénomène se produit surtout en période d'absence de recharge de ces aquifères (sécheresse d'été), les volumes d'eau déplacés correspondent donc aussi à des eaux anciennes plus ou moins riches en sulfates selon l'aquifère considéré.

Références

- COLLIGNON, B. 1986. Hydrogéologie appliquée des aquifères karstiques des monts de Tlemcen (Algérie). Thèse de Doctorat, Université d'Avignon et des pays de Vaucluse, 2 tomes, 282 pages.
- MANGAN, C. 1982. Géologie et hydrogéologie karstique du bassin de la Brague et de ses bordures (Alpes-Maritimes, France). Thèse de spécialité, Université de Nice, 2 tomes.
- MANGAN, C. 1990. Commune de Mouans-Sartoux (06). Etude des disponibilités en eau souterraine pour AEP en partie orientale de la commune. Rapport inédit du Cabinet Mangan.
- MANGAN, C. 1994. Commune de Mouans-Sartoux (06). Dossier synthétique sur le forage de Pinchinade. Rapport inédit du Cabinet Mangan.
- MUDRY, J. 1987. Apport du traçage physico-chimique naturel à la connaissance hydrocinématique des aquifères carbonatés. Thèse d'état, UFR des Sciences et Techniques de Franche Comté-Besançon, 381 pages.

Remerciements :

Les auteurs remercient les responsables de la Régie Municipale des Eaux de Mouans-Sartoux pour leur soutien efficace (prélèvements et mise à disposition des données existantes).

Application of a computational fluid dynamics model to cave river hydrodynamics

M. Hauns¹, F. Hermann² and O. Atteia¹

¹ Centre d'Hydrogéologie de l'Université de Neuchâtel, 11 rue Emile Argand, CH-2007 Neuchâtel

² Versuchsanstalt für Wasserbau der ETH Zürich, ETH-Zentrum, CH-8092 Zürich

Abstract

We show that in some cases the use of a 3-d model solving the Navier-Stokes equations is necessary to simulate flow in karst drains. The presented model is based on the flow solver CFX-F3D. We describe the fundamental set of equations and the finite volume numerical method. Availability of precise cave topography data is a necessary condition. A procedure to generate the grid from field data is outlined. This model has been applied to calculate the relation between velocity and discharge for a flowmeter in the Rinquelle (Kanton St. Gallen, Switzerland). First results show that the model is able to deal with complex cave geometries. With a high flexibility of the solver to add user modules we expect to be able to resolve tracer and particle transport problems in the future.

Key words

computational fluid dynamics, turbulence, free surface, physical speleology (cave topography), tracer experiments, discharge measurements

Introduction and objectives

In a karst aquifer water flows both in the block structure and in drains. Flow in the porous part can be described with models based on Darcy's law (Rossier, 1992). When considering models based on loss of head for drains, the formula of Louis is most adequate for phreatic karst conduits, while the formula of Manning-Strickler works better for vadose conditions (White, 1988). The results are good while the assumptions on which such models are based are valid in the considered case. When simplifying assumptions are not valid any more, higher-dimensional models have to be applied: there are cases where the currents in a cave must be known exactly to make reliable predictions. Simulations of tracer experiments in a drain with a pseudo 2-d river model (FLORIS) did not return correct results (Jeannin, 1996). To obtain recirculation and turbulent dissipation a higher-dimensional model is necessary.

The velocity distribution is important for sedimentation and resuspension of particles and also for the physico-chemical processes between them. It may be interesting to map the topography of a site, usually for low water conditions and then examine numerically what happens at high water: for example there may be recirculation zones that do not exist at normal water levels and where material is deposited at high and falling water level conditions. One-dimensional models are usually restricted to a few parameters thus drain tubes will have the same cross section for a range of discharges, and redistribution of flow to an increasing number of tubes with higher level cannot be taken into account (Jeannin & Wildberger, 1995). The redistribution can be resolved with a local three-dimensional model.

The model presented here is expected to give improved answers to some of the questions mentioned above. The fundamental set of the Navier-Stokes equations, the used numerical method and a procedure to generate the grid from field data are described. An example is given to demonstrate the usefulness of the model for a flow problem in a cave.

1. Influence of the velocity distribution in a drain on tracer experiments

The importance of velocity distribution on tracer transport can be seen on Fig. 1, which shows schematically the

difference between a 1-d simulation and a 2-d simulation for a channel transporting tracer dye. In the 1-d model the velocities will reduce for a wider cross section but no eddies will develop - in a 2-d model a recirculation zone exists. Some tracer substance will be captured therein and when released give a retardation that deforms the measured concentration peak.

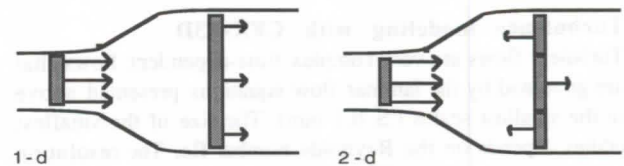

Fig. 1: to resolve tracer substance retarding when captured in an eddy 2-d modelling is necessary

2. Cave hydrodynamics modeling with CFX

The hydrodynamic problem of water flow is described by the Navier-Stokes equations. Topography mapped with sufficient accuracy is needed to solve correctly the equations numerically. While most of the water flows in the main branch of a gallery, sufficient accuracy might be obtained by mapping cross sections every five meters, and the bottom profile to a precision of five centimeters. To deal with very complicated structures like a strainer a precision of 5-10 cm will be needed in all three dimensions.

Formulation of the Navier-Stokes equations

The Navier-Stokes equations can be derived from a general transport equation for extensive quantities (Honerkamp and Römer, 1986). For a fluid or gas dynamics problem the Navier-Stokes equations in coordinate-independent vector notation are:

$$\frac{\partial}{\partial t} \rho + \nabla \cdot (\rho \underline{u}) = 0 \quad (1)$$

$$\frac{\partial}{\partial t} (\rho \underline{u}) + \nabla \cdot (\rho \underline{u} \otimes \underline{u}) = -\nabla p + \Delta(\mu \underline{u}) + B \quad (2)$$

\underline{u} velocity vector p pressure
 ρ fluid density μ dynamic viscosity

B body forces

Equation (1) comes from mass conservation, equation (2) describes the behaviour of an infinitesimal volume element in the fluid exposed to inner and outer forces. Viscous friction, pressure gradient and inertia are examples for inner forces, buoyancy, magnetic or centrifugal are examples for outer forces.

Simplifying assumptions which are generally based on an a-priori integration of the equations for a direction where little change occurs (e.g. the z-direction) lead to lower-dimensional models.

Definition of the fluid dynamic problem

Liquid flow is in general treated as incompressible flow, therefore equation (1) will simplify in the liquid phase. Water is a newtonian fluid, that means the stress tensor will be isotropic. As the temperature of the water changes very little and slowly we consider the problem to be isothermic, there is no buoyancy force due to temperature gradients. Buoyancy forces may be present due to density variations caused by a high salinity. Turbulence modelling is important since colloid particle diffusion and mixing depend on it. Except for sumps and high water conditions, there will be a free surface. Free surfaces can be modelled with a moving grid, but for such beautiful things like breaking waves and bubbly boiling pots after a waterfall multiface modeling is necessary, hence the Navier Stokes equations must as well be solved for the air phase.

Turbulence modeling with CFX-F3D

Turbulent flows are very complex time-dependent flows that are governed by the laminar flow equations presented above in the smallest scales ($\leq 0,1$ mm). The size of the smallest eddies depends on the Reynolds number Re . The resolution required grows with $Re^{9/4}$ (Mohammadi & Pironneau, 1993). For most turbulent problems a grid that resolves the small eddies is not feasible with current technology. Therefore a turbulence model is introduced which solves the transport equations for the Reynolds-averaged quantities:

$$\overline{\Phi}(t) = \frac{1}{2\delta t} \int_{t-\delta t}^{t+\delta t} \Phi(\tau) d\tau \quad (3)$$

$\overline{\Phi}$ represents any averaged quantity, e.g. velocity, pressure. It is important that the frequency of turbulent fluctuations and the frequency of mean value fluctuations are well separated. So δt in eq. (4) can be chosen large relative to the time scale of turbulent fluctuations, but small relative to the time scale of the problem we wish to solve. Under this assumption, fields can be split into their mean and fluctuating parts:

$$\Phi = \overline{\Phi} + \Phi' \quad (4)$$

With the laws for the averaged quantities, equation (2) can be rewritten in Reynolds-averaged form:

$$\frac{\partial}{\partial t}(\rho \underline{u}) + \nabla \cdot (\rho \underline{u} \otimes \underline{u}) = -\nabla p + \Delta(\mu \underline{u}) - \nabla \cdot (\rho \overline{\underline{u}' \otimes \underline{u}'}) \quad (5)$$

where the bars for all variables as well as the body force term have been dropped for clarity. The additional term $\nabla \cdot (\rho \overline{\underline{u}' \otimes \underline{u}'})$ describes the influence of the turbulent eddies on the mean flow and has the dimension of a stress. One

possibility to model it is by introducing turbulent viscosity by setting $\overline{\underline{u}' \otimes \underline{u}'} = \nu_t(\nabla \underline{u} + \nabla \underline{u}^T)$.

Free surface modeling with CFX-F3D

In a partially filled drain the free surface of the water must be computed. Free surfaces may be modelled with a moving grid, but in torrential flow mixing with air is important so we use a multiphase formulation. The free surface is then defined as the interface between the two phases. A surface sharpening algorithm helps to overcome the numerical diffusion at the surface.

Particle and tracer transport modeling

In CFX-F3D tracer transport can be expressed by means of an additional scalar equation while the tracer particles have no inertia and the same density as the surrounding liquid and will therefore always move with the same velocity as the fluid. When the particles have a different density a two fluid model must be applied. For high particle concentrations there is a coupling between the momentum equations, but for a tracer experiment and colloid particle transport modelling this can be neglected.

Numerical Solution

The set of equations described above has to be discretized and solved within a computational domain. This may be done with a finite difference, finite volume or finite element method. We chose to work with the finite volume method because it is fast and offers a body-fitted grid. There is a computational grid that is always topologically rectangular in this numerical method and a physical grid which adapts to the shape of the gallery. A procedure to create the physical grid from field data is described later. For simple calculations the physical grid is identical to the computational grid, but for most of our applications it will be distorted and has to be mapped to the computational grid. Fig. 2a shows a scheme of the two grids.

The advantage of a body fitted physical grid is that the velocity vectors are more likely to be parallel to the cell bounds than in a rectangular grid and that no cells are wasted in complex geometries.

The transformation between the two grids involves elements of tensor calculus and will later influence the differencing scheme for the equations. The Navier Stokes equations will contain additional force terms originating from the transformation of an isotropic advection-diffusion problem in physical space to an anisotropic advection-diffusion problem in computational space.

The physical grid has always to be structured, therefore the geometry is not as arbitrary as is with unstructured grids. To describe complex structures it is necessary to join several subgrids. Fig. 2b shows an example for a composite grid in a conduit.

The volume between neighbouring points will be referred to as a volume element, generally a parallelepiped. In CFX-F3D the variables are discretized at the centers of these elements, and the equations are discretized treating these elements as control volumes for the conservation laws. The Navier-Stokes equations have to be satisfied for each control volume simultaneously. The default differencing scheme is UPWIND, but several higher order schemes can be chosen. The SIMPLEC algorithm is used for velocity-pressure coupling.

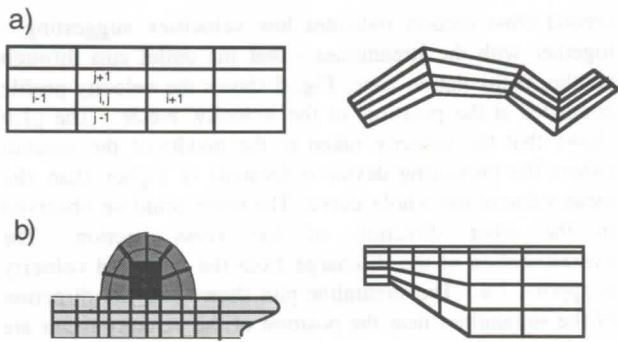

Fig. 2: a) physical grid fitted to an irregular channel and corresponding computational grid. b) body fitted grid for varying channel geometries - blocks are shaded (see fig. 3 for flow pattern classification).

3. Grid generation from field data

Underground rivers flow in galleries that may be located both in the the vadose and phreatic zone of karst aquifers. We may focus on the vadose (non-saturated) zone where field data are obtained more easily. Non-saturated drains show a wide variety of flow patterns with frequent change between fluvial and torrential flow. Basic flow patterns are classified in Fig. 3. Big lakes are separated by series of cascades, ramp-type rapids and calm channels follow each other (Marechal, 1994).

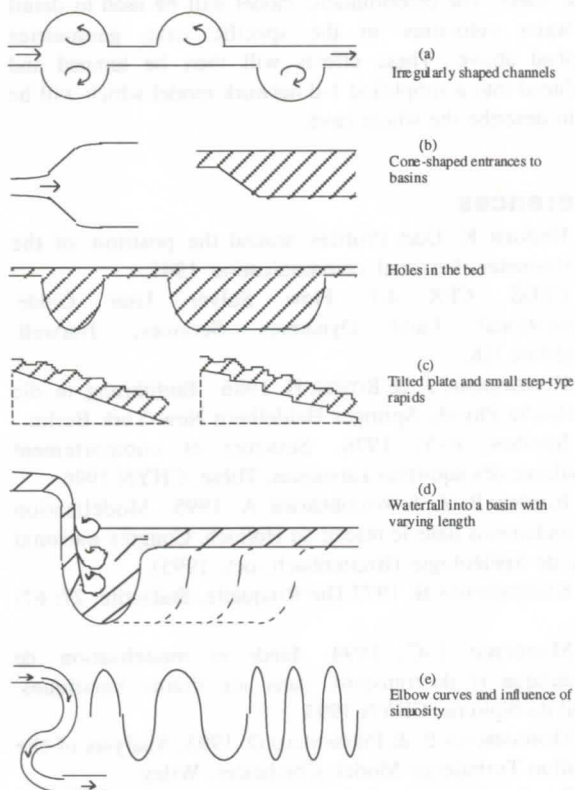

Fig. 3: basic flow patterns in vadose karst conduits

There are a few important rules to obey for grid generation: a body-fitted grid should be as orthogonal as possible, especially where gradients are high. The spacing of the grid may vary to be more precise at "hot spots" (volumes where the variables change fast), but the variation has to be smooth.

The physical grid is created from sections of the cave and a profile in geographic xyz coordinates of the cave floor. The sections may be digitized from drawings with an arbitrary number of points. A polygon is fitted to each cross section and placed onto the profile of the cave floor. The volume between two subsequent sections is called a block.

4. Application to cave hydrodynamics

The 'Rinquelle' cave is located north of 'Walensee' in eastern Switzerland. It consists of a long (approx. 1 km) underwater gallery with two branches. One of these feeds a spring, which is active during summer and inactive in winter time, the other one starts about 300m after the entrance of the sump and is the main outflow branch of the system. It's explored length is approx. 800m. It's emerging point lies at the bottom of the Walensee. To gain insight into the flow regime of the cave, flow meters were installed in the spring and in the other outflowing branch. The latter is a flow velocity meter, located roughly in the middle of the gallery. With the assumption of uniform flow, the discharge may be calculated by $Q=V \cdot A$, where A is the cross section and V the mean flow velocity. However, the topography of the gallery suggests that the assumption of a uniform velocity distribution might not be fulfilled. In order to find out more about that, a numerical simulation of the flow through a part of the gallery was performed and the resulting flow field analysed. The grid consists of ca. 19000 cells. The calculation took slightly more than an hour on a modern workstation. Turbulence was modelled with the commonly used k-ε model. Fig. 4a and 4b show the computational grid used, Fig. 5 gives an impression of the flow behaviour by the use of streamlines and grey-coded cross-sections (lowest velocity dark grey) and Fig. 6 shows a velocity profile modelled at the place of the velocity meter. The streamlines in Fig. 5 start in a plane near the entrance, covering the whole vertical extent. Note, that the upper two groups of streamlines are not affected by the deep part of the conduit, while the lower ones are kept in the large recirculation zone. Some of them escape towards the outlet.

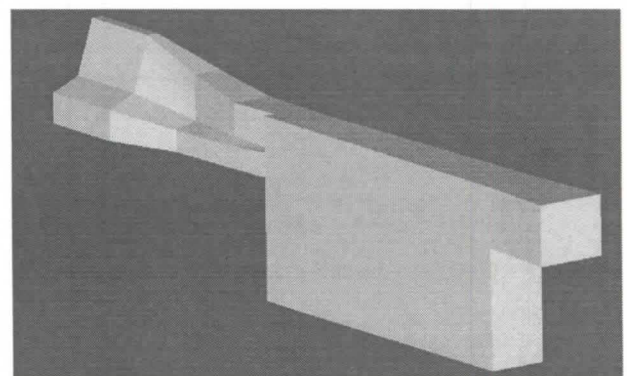

Fig. 4a: Outline of the computational domain which represents a small part of the Rinquelle system. Inflow is at the square face to the right, outflow in the upper left corner. The dimensions are 15 x 7 x 3.2 meters, the inflow velocity is 1m/s.

Another interesting observation may be made at the outlet, where all the streamlines concentrate at the right side of the duct. The grey shaded cross-sections show the velocity distribution at the end of the deep part and at the outlet. In

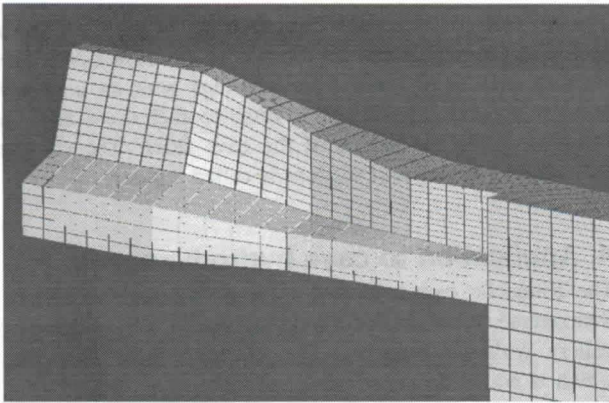

Fig. 4b: Grid structure of a part of Fig. 4a. The grid consists of several blocks glued together. The spacing in the streamwise direction is 50 cm.

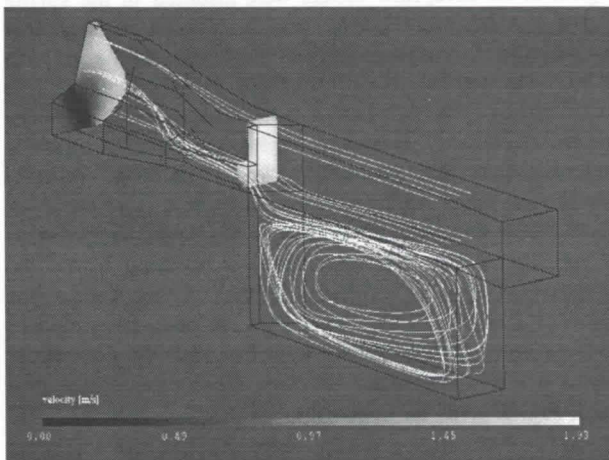

Fig. 5: Flow field in the duct of Rinquelle, visualised by streamlines and grey-shaded cross-sections. See explanations in the text.

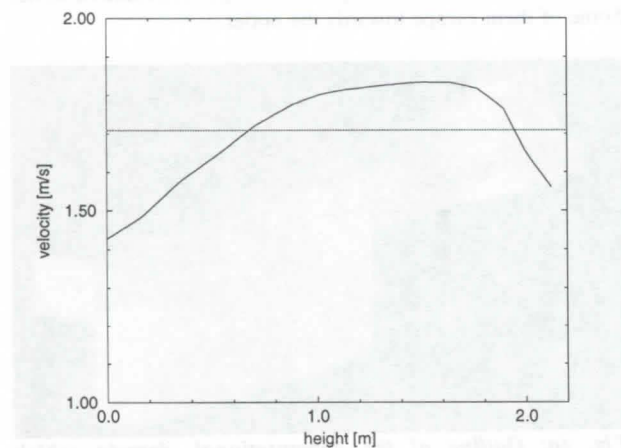

Fig. 6: Velocity (streamwise component) distribution along a vertical line in mid-duct at the position of the velocity-meter, located slightly behind the first cross-section of Fig. 5. The straight line shows the mean value of the velocity, which is lower than the local value in mid-duct.

the first cross-section, the highest velocities are in the middle of the conduit (see also Fig. 6), while they are near the right boundary at the outlet. The black zone in the

second cross-section indicates low velocities suggesting - together with the streamlines - that the outlet cuts through another recirculation zone. Fig. 6 shows the velocity profile computed at the position of the velocity meter. The plot shows that the velocity taken in the middle of the conduit (where the measuring device is located) is higher than the mean value of the whole curve. The same could be observed in the other direction of the cross section. The overestimation of the discharge from the measured velocity is approx. 7%. The streamline plot shows that the direction of the streamlines near the position of the velocity meter are roughly parallel to the main direction of the gallery, giving confidence that the measured values are correct to the accuracy of the device.

5. Conclusion

Comparison of tracer experiments with existing double porosity and 1-d or pseudo 2-d models has shown that they do not represent correctly the hydrodynamics and flow patterns in a drain. The presented approach gives a physical solution for the flow and the shape of the free surface. This is useful for velocity/discharge calculations but also for the interpretation of tracer experiments in drains and for particle dynamics modeling. Due to computational resources and data required, this model is well-suited to solve flow locally and to obtain information about physical variables that influence other processes of interest, e.g. particle dynamics in the water. The deterministic model will be used to detail the water velocities in the specific cave geometries described above. These effects will then be lumped and introduced into a simplified 1-d network model which will be able to describe the whole cave.

References

- BROGER K. Duct Profiles around the position of the velocity-meter. Personal communication 1991.
- CFDS. CFX 4.1 Flow Solver User Guide. Computational Fluid Dynamics Services, Harwell, Oxfordshire UK.
- HONERKAMP, J. & RÖMER H. 1986. Einführung in die theoretische Physik. Springer Heidelberg New York Berlin.
- JEANNIN, P.-Y. 1996. Structure et comportement hydraulique des aquifères karstiques. Thèse, CHYN 1996.
- JEANNIN P.-Y. & WILDBERGER A. 1995. Modélisation des écoulements dans le réseau du Hölloch. Congrès national suisse de Spéléologie (Breitenbach, oct. 1995).
- KLINGENFUSS B. 1977 Die Rinquelle. Stalactite, 27: 67-92.
- MARECHAL J.-C. 1994. Etude et modelisation de l'hydraulique et du transport dans les drains karstiques. Travail du diplôme, CHYN 1994.
- MOHAMMADI B. & PIRONNEAU O. 1993. Analysis of the K-Epsilon Turbulence Model. Chichester: Wiley.
- ROSSIER Y. & KIRALY L. 1992. Effet de la dilution sur la détermination des dispersivités par interprétation des essais de traçage dans les aquifères karstiques. Bull. du Centre d'hydrogéologie de Neuchâtel, 11: 1-15.
- TRÖSCH J. AND ZURBRÜGG C. 1995. Turbulent flow in high permeable karst. Numerical simulation, Bulletin d'Hydrogeologie No 14, 235-240.
- WHITE W. B. 1988. Geomorphology and hydrology of karst terrains. Oxford University Press, Oxford, 464 pp.

Characterization of karst aquifers by heat transfer

by Dirk Hückinghaus, Rudolf Liedl & Martin Sauter
Applied Geology, University of Tübingen, Sigwartstr. 10, 72076 Tübingen, Germany

Abstract

The paper presents a modelling approach which couples the hydraulically complex flow system and the heat transport processes within karst aquifers. Using this model together with quantitative measurements of flow and temperature in karst springs, it will be possible to obtain detailed information about the geometry (surface, diameter, etc.) of the conduit system.

Zusammenfassung

In diesem Beitrag wird ein Modellansatz vorgestellt, der die komplexe Hydraulik eines Karstaquifers und dessen Wärmefluß vereinigt. In Verbindung mit quantitativen Durchfluß- und Temperaturmessungen in Karstquellen, wird es mit diesem Modell möglich sein, mehr und detailliertere Informationen über das Röhrensystem eines Karstaquifers zu erfahren.

1. Introduction

Groundwater flow in karst aquifers is controlled by two coupled hydraulic systems, i. e. a conduit network consisting of relatively large fractures or tubes and a system of small fissures within the rock matrix.

These two flow systems show very different kinds of flow behaviour. The high storage system responds rather slowly to recharge events, while at the same time a fast response can be attributed to the low storage high flow velocity conduit system. ATKINSON (1977) demonstrated that it is mainly the flow in the conduit system that dominates the groundwater flow.

Due to the high flow velocity (up to 100 m/h) in the tubes, information about the geometry of the conduit network is an essential prerequisite for groundwater risk assessment. Recent investigations have shown that it is possible to obtain information about the network geometry from temperature deviations in karst springs after recharge events (BENDERITTER et al., 1993; ROY & BENDERITTER., 1986; RENNER, 1996).

This paper presents a new modelling approach which takes into account the two different flow systems and the heat transport processes in the conduit system and the rock matrix. It is intended to utilise this model in order to

obtain more information about the structure of the conduit network and about the geometrical parameters of the tubes (diameter, length) based upon measurements of karst spring discharge and temperature.

2. Observations

After recharge events characteristic responses of temperature have been observed in karst springs (Fig. 1). In many karst systems the temperature deviations are independent of seasonal atmospheric temperature fluctuations (ALEY, 1970; HESS et al., 1988; DAVIES, 1992). In order to produce this characteristic phenomenon, three conditions have to be fulfilled (RENNER, 1996): (1) a sufficiently thick unsaturated zone to provide significant temperature differences between the atmosphere and the aquifer, (2) a sufficient residence time in the upper cooler region (epikarst) of the unsaturated zone so that the recharge water can adjust its temperature to the surrounding rock, and (3) a rapid seepage from the epikarst through the vadose zone to retain a difference in temperature between the seepage water and the water in the phreatic zone (Fig. 2).

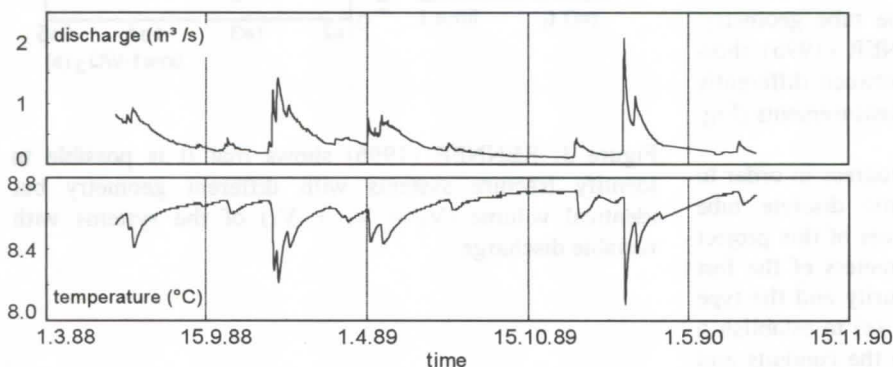

Figure 1: Time series of spring water temperature and discharge variation in the Gallusquelle (Swabian Alb, SW Germany) karst spring (RENNER, 1996; data from Sauter, 1992).

Consequently, in this case the temperature of the seepage water reaching the groundwater table is lower than the aquifer temperature disregarding seasonal fluctuations of the atmospheric temperature. Then the seepage water is collected by large fractures or tubes and transferred to the karst spring at flow velocities in the order of 100 m/h. Therefore the adaptation of the recharge water temperature to the higher aquifer temperature is delayed and the temperature pulse of the recharge event reaches the spring, where it can be measured.

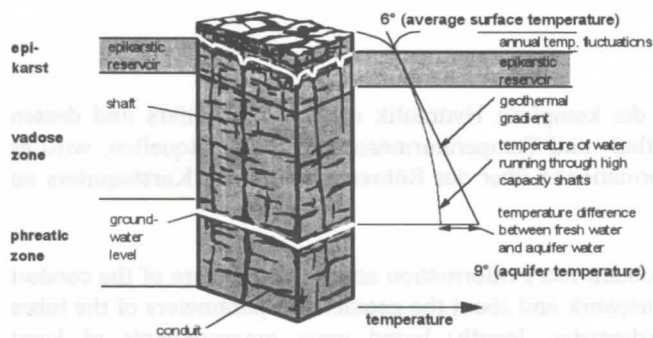

Figure 2: Seepage through the unsaturated zone: the recharge water accumulates in the epikarst reservoir before seeping through the vadose zone along highly permeable fractures (RENNER, 1996).

3. Objectives and conceptual model

The field observations summarised above promote the idea of characterising the conduit system of karst aquifers by using spring water temperature data. RENNER (1996) has demonstrated that this is possible for aquifers with a highly interconnected conduit system which can be represented by a single 'equivalent' fracture.

If there is a temperature difference between the inflow in the tube and the surrounding soil matrix a heat transfer between tube and matrix occurs. The transfer is controlled by the flow velocity, the thermal characteristics of the surrounding rock and by the geometry of the tubes. Hence the measured temperature in the spring behaves analogously to tracer transport. If we know the input and rock temperature and the flow velocity in the tube it is possible to obtain information about the tube geometry. Recent numerical calculations by RENNER (1996) show that it is even possible to distinguish between differently shaped tube systems using temperature measurements (Fig. 3).

At present, a research project is in progress in order to transfer this approach to more realistic discrete tube networks. In particular, the main objectives of this project are (a) to identify the geometrical parameters of the fast flow system, (b) to characterise the maturity and the type ("shallow" or "deep") of a karst aquifer, (c) to establish a mathematical model of heat transport in the conduits and the rock matrix, and (d) to implement this heat transport module into an existing groundwater flow model for karst aquifers (CLEMENS et al., 1996) in order to apply it to karst catchments in the Swabian Alb (SW Germany).

In order to reach objective (c) a conceptual model of flow and heat transport in karst systems has to be

established. The flow model is based upon a distinction between a slow and a fast flow system. The slow flow in the small fissures is modelled by a continuum approach using the Boussinesq equation (BEAR & VERRUIJT, 1987). The large conduits are represented by a pipe network consisting of cylindrical tubes. The flow in this conduit system is modelled by regarding the conservation of mass according to Kirchhoff's rule (CLEMENS et al., 1996). The two flow systems are coupled by an exchange term. This approach is used in the program system CAVE (Carbonate Aquifer Void Evolution) which was developed to simulate the genesis of a karst system (HÜCKINGHAUS et al., 1997; CLEMENS et al., 1997).

For heat transfer modelling it is assumed that convection is the dominant process within the tubes, whilst heat transport in the rock matrix is governed by conduction perpendicular to the tubes (Fig. 4). Additionally, heat exchange between the rock matrix and the conduits has to be considered.

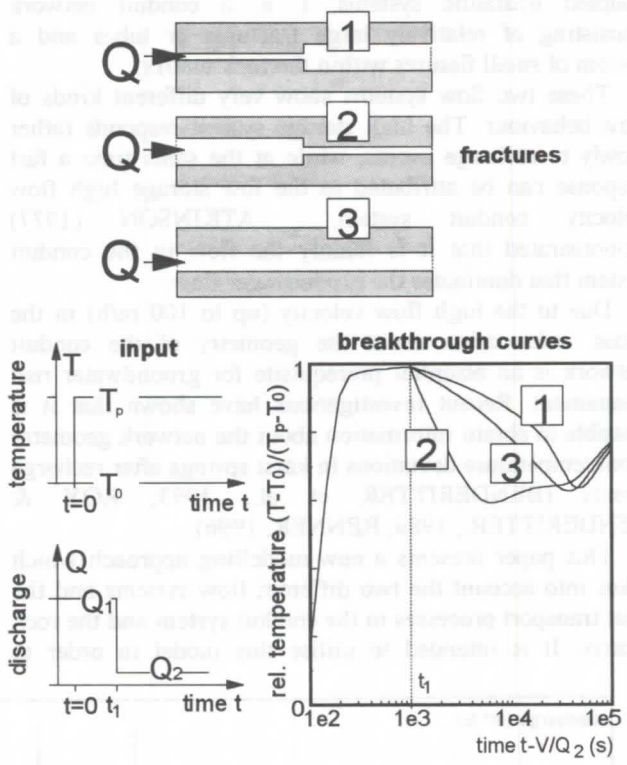

Figure 3: RENNER (1996) shows that it is possible to identify fracture systems with different geometry but identical volume ($V_1 = V_2 + V_3$) of the systems with variable discharge.

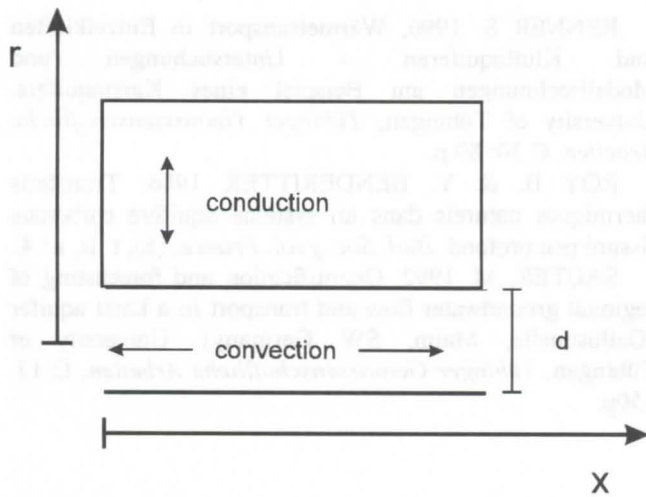

Figure 4: Important processes of heat transfer present in the rock and tube system.

4. Mathematical model

Heat conduction in the rock matrix is described by the differential equation (cylindrical coordinates)

$$\frac{\partial T_{sol}}{\partial t} = \frac{\lambda_{sol}}{\rho_{sol} c_{sol}} \left(\frac{\partial^2 T_{sol}}{\partial r^2} + \frac{1}{r} \frac{\partial T_{sol}}{\partial r} \right) \quad (1)$$

where T_{sol} is the temperature of the rock, t is time, r is the radial coordinate in the cylindrical system, λ_{sol} is the thermal conductivity of the rock, ρ_{sol} is the density of the rock and c_{sol} is the specific heat capacity (CARSLAW & JAEGER, 1959).

The convective transport of heat in the flow direction x along each tube can be described by

$$\frac{\partial T_{fl}}{\partial t} = \frac{\lambda_{sol} A}{\rho_{fl} c_{fl} V} \frac{\partial T_{sol}}{\partial r} \Big|_{r=d/2} - v \frac{\partial T_{fl}}{\partial x} \quad (2)$$

with the fluid temperature in the tube T_{fl} , the flow velocity v , the density of the fluid in the tube ρ_{fl} , the specific heat capacity c_{fl} of the fluid, the tube diameter d , the volume of the tube V and the surface of the tube A . The first term on the right hand side represents the exchange of heat between the rock matrix and the conduit water. At the surface of the tube both temperatures are identical, i. e.

$$T_{sol}(x, r = \frac{d}{2}, t) = T_{fl}(x, t) \quad (3)$$

For a single tube it is possible to find solutions of eqs. (1) - (3) in the Laplace space for a uniform initial temperature T_0 and a temporally constant water temperature T_{imp} at the inlet of the tube. If the symbol $\hat{}$ denotes Laplace transformation we obtain

$$\hat{T}_{fl}(x, s) = T_0 + \frac{T_{imp} - T_0}{s} *$$

$$* \exp \left\{ - \left(s + \frac{\lambda_{sol} A K_1(pd/2)p}{\rho_{fl} c_{fl} V K_0(pd/2)} \right) \frac{x}{v} \right\} \quad (4)$$

and

$$\hat{T}_{sol}(x, r, s) = \hat{T}_{fl}(x, s) \frac{K_0(rp)}{K_0(pd/2)} \quad (5)$$

where $p = \sqrt{\rho_{sol} c_{sol} s / \lambda_{sol}}$ and s is the Laplace variable. The functions K_0 and K_1 are modified Bessel functions of integer order (ABRAMOWITZ & STEGUN, 1970).

The temperatures T_{fl} and T_{sol} are obtained by applying the inverse Laplace transform to the equations (4) and (5). A computer program using the numerical inversion of Laplace transforms is currently being developed.

5. Summary and outlook

It has been shown that field observations support the idea of characterising the fast flow system of karst aquifers by analysing spring water temperatures. To this end, a new numerical model is being developed which couples the two different flow systems in a karst aquifer to heat transfer processes in the conduit system and in the rock matrix.

It is planned to continue the research activities as follows: in a first step the numerical solutions for a single tube will be verified. Next, this solution will be implemented in the CAVE program in order to obtain a modelling tool for the simulation of flow and transport in a discrete conduit network which is coupled to a continuum model representing the rock matrix. Finally, this combined model will be applied to karst areas in the Swabian Alb (SW Germany) where presenting measurements of spring water temperature are being carried.

References

- ABRAMOWITZ, M. & I. A. STEGUN 1970: Handbook of Mathematical Functions. Dover Publishing Co., New York.
- ALEY, T. J. 1970. Temperature fluctuations of a small Ozark spring. *Caves and Karst*, Vol. 12, No. 4.
- ATKINSON, T. C. 1977. Diffuse flow and conduit flow in limestone terrain in the Mendip Hills, Somerset (Great Britain). *Journ. Hydrol.*, 35: 93 - 100.
- BEAR, J. & A. VERRUIJT 1996: Modelling groundwater flow and pollution, D. Reidel Publishing Compan, Dordrecht, 414 p.
- BENDERITTER Y.; ROY B. & A. TABBAGH 1993. Flow characterization through heat transfer evidence in a carbonate fracture medium: First approach. *Water Resour. Res.*, 29, (11):3731-3747.
- CARSLAW H. S. & J. C. JAEGER 1959: Conduction of heat in solids, 2nd ed., Oxford University Press, London, 510 p.
- CLEMENS, T.; HÜCKINGHAUS, D.; SAUTER, M.; LIEDL R. & G. TEUTSCH 1996. A combined continuum and discrete network reactive transport model for the simulation of karst development. *IAHS Publ.* 237: 309-318.
- CLEMENS, T.; HÜCKINGHAUS, D.; SAUTER, S.; LIEDL, R. & G. TEUTSCH 1997. Simulation of the

development of karst aquifers using a pipe flow model coupled to a continuum model - 2. Model verification and sensitivity analysis., *Water Resour. Res.*, in prep.

DAVIES, G. J. 1992. Water temperature variation at springs in the Knox Group near Oak Ridge, Tennessee. *Proceedings of Ground Water in Karst Terranes*.

HESS, J. W. & W. B. WHITE 1988. Storm response of the karstic carbonate aquifer of Southcentral Kentucky. *Journ. Hydrol.*, **99**, 235 - 252.

HÜCKINGHAUS, D.; CLEMENS, T.; LIEDL, R.; SAUTER, M. & G. TEUTSCH 1997. Simulation of the development of karst aquifers by using a pipe flow model coupled to a continuum model - 1. Theory, *Water Resour. Res.*, in prep.

RENNER S. 1996, Wärmetransport in Einzelklüften und Kluftaquiferen - Untersuchungen und Modellrechnungen am Beispiel eines Karstaquifers. University of Tübingen, *Tübinger Geowissenschaftliche Arbeiten*, C 30: 89 p.

ROY B. & Y. BENDERITTER 1986. Transferts thermiques naturels dans un système aquifère carbonate fissuré peu profond. *Bull. Soc. géol. France*, (8), t. II, n° 4.

SAUTER, M. 1992. Quantification and forecasting of regional groundwater flow and transport in a karst aquifer (Gallusquelle, Malm, SW Germany). University of Tübingen, *Tübinger Geowissenschaftliche Arbeiten*, C 13, 150p.

4. Summary and outlook

The pipe flow model has been used to describe the flow and transport in karst aquifers. The model is based on the assumption that the karst system can be represented by a network of pipes. The model is coupled to a continuum model to describe the flow and transport in the matrix. The model is used to simulate the development of karst aquifers and to forecast regional groundwater flow and transport.

It is planned to extend the research activities in the future. The model will be applied to a karst system in the Tübingen area. The model will be used to simulate the development of karst aquifers and to forecast regional groundwater flow and transport. The model will be used to simulate the development of karst aquifers and to forecast regional groundwater flow and transport.

References

ARONOWITZ, M. & J. A. STEIN 1970. *Handbook of Hydrology*. McGraw-Hill, New York.

DAVIES, G. J. 1992. Water temperature variation at springs in the Knox Group near Oak Ridge, Tennessee. *Proceedings of Ground Water in Karst Terranes*.

HESS, J. W. & W. B. WHITE 1988. Storm response of the karstic carbonate aquifer of Southcentral Kentucky. *Journ. Hydrol.*, **99**, 235 - 252.

HÜCKINGHAUS, D.; CLEMENS, T.; LIEDL, R.; SAUTER, M. & G. TEUTSCH 1997. Simulation of the development of karst aquifers by using a pipe flow model coupled to a continuum model - 1. Theory, *Water Resour. Res.*, in prep.

RENNER S. 1996, Wärmetransport in Einzelklüften und Kluftaquiferen - Untersuchungen und Modellrechnungen am Beispiel eines Karstaquifers. University of Tübingen, *Tübinger Geowissenschaftliche Arbeiten*, C 30: 89 p.

ROY B. & Y. BENDERITTER 1986. Transferts thermiques naturels dans un système aquifère carbonate fissuré peu profond. *Bull. Soc. géol. France*, (8), t. II, n° 4.

SAUTER, M. 1992. Quantification and forecasting of regional groundwater flow and transport in a karst aquifer (Gallusquelle, Malm, SW Germany). University of Tübingen, *Tübinger Geowissenschaftliche Arbeiten*, C 13, 150p.



Figure 4: Important processes in karst aquifers. The flow and transport processes.

4. Mathematical model

The mathematical model is based on the assumption that the karst system can be represented by a network of pipes. The model is coupled to a continuum model to describe the flow and transport in the matrix.

The model is used to simulate the development of karst aquifers and to forecast regional groundwater flow and transport. The model is used to simulate the development of karst aquifers and to forecast regional groundwater flow and transport. The model is used to simulate the development of karst aquifers and to forecast regional groundwater flow and transport.

The model is used to simulate the development of karst aquifers and to forecast regional groundwater flow and transport. The model is used to simulate the development of karst aquifers and to forecast regional groundwater flow and transport.

$$Q = \frac{\Delta H}{R} \quad (1)$$
$$R = \frac{L}{A} \quad (2)$$

where Q is the discharge of the pipe, ΔH is the head difference across the pipe, L is the length of the pipe, and A is the cross-sectional area of the pipe. The model is used to simulate the development of karst aquifers and to forecast regional groundwater flow and transport.

$$Q = \frac{\Delta H}{R} \quad (3)$$
$$R = \frac{L}{A} \quad (4)$$

where Q is the discharge of the pipe, ΔH is the head difference across the pipe, L is the length of the pipe, and A is the cross-sectional area of the pipe. The model is used to simulate the development of karst aquifers and to forecast regional groundwater flow and transport.

$$Q = \frac{\Delta H}{R} \quad (5)$$
$$R = \frac{L}{A} \quad (6)$$

where Q is the discharge of the pipe, ΔH is the head difference across the pipe, L is the length of the pipe, and A is the cross-sectional area of the pipe. The model is used to simulate the development of karst aquifers and to forecast regional groundwater flow and transport.

Dispersion and tailing of tracer plumes in a karstic system (Milandre, JU, Switzerland)

Pierre-Yves Jeannin¹ & Jean-Christophe Maréchal^{1,2}

¹ Centre d'hydrogéologie de l'Université de Neuchâtel, Rue Emile-Argand 11, CH-2007 Neuchâtel, Switzerland

² Now at Ecole Polytechnique Fédérale de Lausanne (EPFL), Geolep, CH-1015 Lausanne, Switzerland

Abstract

A large number of tracing experiments have been carried out in a karstic aquifer in the Swiss Jura. These allow to observe the evolution of a tracer plume along the length of a karst conduit. The method of Sauty was used to make possible the comparison between all the observed breakthrough curves.

The flow velocities and the dispersivities obtained are extremely variable. The dispersivities measured at different points along the length of an underground stream in the course of the same tracing experiment increase with distance (scale effect).

If the fit of theoretical Sauty curves on the experimental curves works well for rising limbs, this is not always the case for falling limbs: a tailing effect or lag of the experimental curves compared to the theoretical ones is often observed. Micro-tracings have shown that the lag effect is linked more to the karst conduit geometry than to the types of flows (turbulent or laminar). Measurable tailing effect is induced by the presence of a single conduit enlargement (also called pool). Further, the experiments have shown that a succession of enlargements along the length of the underground stream causes a clear increase in the dispersivity and a "homogenisation" of the recovery curve which shows up by the apparent disappearance of the lag effect.

These observations show clearly the influence of the heterogeneity of the karst conduit geometry on the breakthrough curves. This effect might be considered when one interprets the shape of the breakthrough curves especially for dispersivity estimation.

Résumé

De nombreux essais de traçage ont été réalisés dans un aquifère karstique du Jura suisse. Ils permettent d'observer l'évolution du nuage de traceur le long d'un conduit. La méthode de Sauty a été utilisée pour rendre les diverses courbes de restitution comparables.

Les vitesses et les dispersivités obtenues sont extrêmement variables. Les dispersivités mesurées en différents points le long du ruisseau souterrain au cours d'un même traçage augmentent avec la distance (effet d'échelle).

Si l'ajustement des courbes théoriques de Sauty sur les courbes expérimentales fonctionne bien sur la montée, il n'en va pas toujours de même pour la descente: un effet de retard (tailing effect) des courbes expérimentales par rapport aux courbes théoriques est souvent observé. Des micro-traçages ont montré que l'effet de retard est davantage lié à la géométrie des conduits karstiques qu'à la nature des écoulements (turbulents ou laminaires). Un effet de retard mesurable est induit par la présence d'un seul large bassin. Les expériences ont également montré que la succession de plusieurs bassins le long du ruisseau souterrain induit une nette augmentation de la dispersivité (effet d'échelle) et une "homogénéisation" de la courbe de restitution se traduisant par une disparition apparente de l'effet de retard.

Ces observations montrent l'influence des variations de la géométrie des conduits karstiques sur les courbes de restitution des traceurs. Cet effet devrait être pris en considération lors de l'interprétation des courbes de restitution notamment lors de l'estimation de la dispersivité du milieu.

1. Introduction

In karstic aquifers, the dispersivity values measured on breakthrough curves are often high (MEUS 1993), scale depending and the shape of the breakthrough curves is frequently strongly asymmetric (MARECHAL 1994). These results do not fit well with results of a theoretical 1-D homogeneous model, assuming that conduits are thin but very conductive features (pipes). The discrepancies between the 1-D model and the observations leads many authors to consider further processes generating dispersion namely adsorption-desorption (DE MARSILY 1986), a large molecular diffusion (SEILER *et al.* 1989, MALOSZEWSKI & ZUBER 1989), interaction with stationary water (BIVER 1993), the effects of dilution (ROSSIER & KIRALY 1992), etc...

This paper is focussed on describing the relation between the flow conditions in karst conduits and the breakthrough curves. The « low permeability volumes » surrounding the conduits in karst aquifers are not under consideration here.

Breakthrough curves could be observed along the path of an underground karstic flow and provide then informations about the dispersion processes which could be responsible for the strong asymmetrical breakthrough curves frequently observed in karst systems.

2. The test-field of Milandre

The drainage basin of the Milandrine (13km²), situated in the north of Switzerland, contains an underground river - the Milandrine - which can be followed upstream from the emergence point for 4.6 km (actual distance in the cave, equivalent to 3 km as the crow flies, figure 1). The exsurgence of the Milandrine is made up of two principal springs, one perennial, the Saivu, with a discharge of 20 - 150 l/s and the other ephemeral, La Bâme, with a discharge of 0 to 1500 l/s. Four measuring stations were set up along the length of the underground river, allowing to measure the passage of tracers along the section to be observed. The measuring stations are situated at 4.6 km from the springs (station 1, upstream of the cave), at 4 km (station 1'), 3 km (station 2), 1.5 km (station 3) and 0 km (station 4, springs themselves) respectively. The flow is open along the largest part of the underground river, with only the downstream part, of about 500 metres in length being constricted.

About sixty tracing experiments were carried out on this site by injecting NaCl (50 to 500 kg) at different points in the drainage basin upstream from the known part of the cave. The breakthrough curves are obtained at each station by measuring the electrical conductivity of the water and by transforming it into NaCl concentrations.

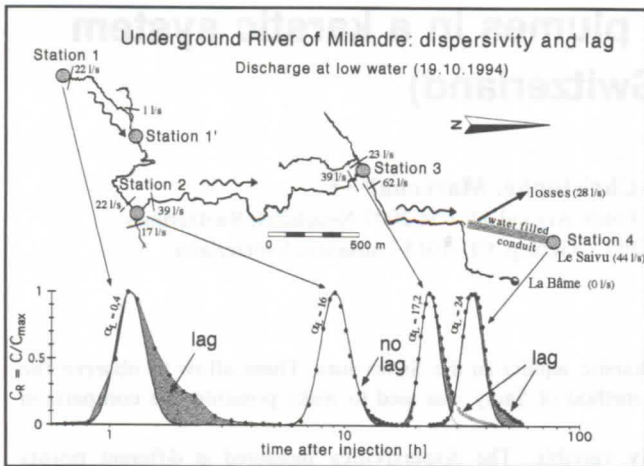

Figure 1 : The tracers are generally observed at four or five stations. The tracing experiment (Tracing 42 in table 1) presented here show a clear increase in dispersivity (α_L) along the underground course of the river (scale effect). The tailing effects vary a great deal along the length of the flow.

3. Aims and methods

A frequent tailing effect (strongly asymmetrical breakthrough curves) has been observed in Milandre. Does this retardation come from adsorption-desorption processes, from diffusion of tracer in the matrix, from dilution, or from any other process? Direct observations in the cave, make it possible to be almost sure that none of these processes are significant: there is no clays for adsorption-desorption, the porosity of the matrix is very low (<2%) and the flow velocity too high for a substantial diffusion in the matrix or towards immobile water, there is no tributary, at least along certain sections, causing a dilution effect. As scale and tailing effects are observed anyway, we will discuss here some further processes which may be responsible for. In order to be able to compare the many breakthrough curves we measured, only those carried out in similar hydraulic conditions (at low water levels) have been considered. The changes of the parameters as a function of discharge could be the subject of a future paper.

The breakthrough curve

Following the injection of a tracer, the concentration $C(X,t)$ of a solute obtained at an observation point situated at a distance X from the injection point is expressed as a function of time. This is the breakthrough curve.

The modal transit time (t_m) represents the largest number of tracer particles: it is therefore the time value with the highest probability. This time is used for calculating the «modal velocity» (X/t_m) which is the velocity given in table 1.

The Sauty method

In order to compare the breakthrough curves, the simplest possible model has been used (Sauty method). This model is easy to calibrate and does not introduce any of the dispersion processes described before. It provides physical parameters (dispersivity) but in this study, it is utilised as a tool of comparison, not as a physical model of the reality. We mainly focus on the tailing effect (difference between the model and the breakthrough curve) and the spatial variation of the calculated dispersivity (apparent dispersivity).

SAUTY (1977) provides a series of theoretical curves that have been calculated using a uniform, uni-dimensional, laminar flow model.

Each of the theoretical curves corresponds to a hydrodynamic Peclet number.

The experimental breakthrough curves are superimposed on the theoretical curves and adjusted to the one giving the best fit. From the appropriate Peclet number, we easily calculate the dispersivity which is equal to the distance divided by the Peclet Number.

The retardation or tailing effect

To obtain a dispersivity value, Sauty suggest to fit both the theoretical curves and the experimental curves on the rising limb of the peak (figure 2).

In most cases, the curve fitted on the rising limb does not then adjust correctly on the fall. It is therefore possible to make several successive fits and to determine several longitudinal dispersivities for different parts of the falling limb of the curve.

Generally the experimental curve remains above the theoretical curve of Sauty in the falling limb of the peak. This is the so called « tailing effect ».

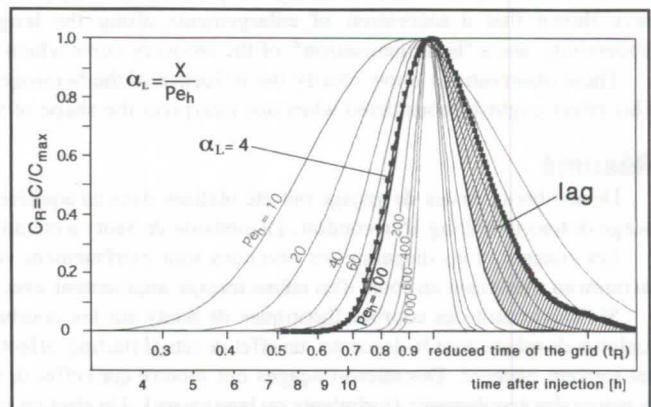

Figure 2 : Fitting of the curve on Sauty grids. The fitting is carried out on the rising limb of the curve and gives a value for dispersivity α_L . A lag effect of the experimental curve with respect to the Sauty model is visible.

4. Results and discussion

Apparent dispersivity: scale effect

The dispersivities measured on the rising limbs of the breakthrough curves at different points along the Milandrine during the same tracing (Table 1) almost systematically rise as a function of the distance.

This increase in dispersivity shows the existence of a scale effect: if the distance increases, the probability of encountering many and large dispersive phenomena also increases.

This scale effect is well known in heterogeneous media (PTAK & TEUTSCH 1994, SEILER *et al.* 1989, SAUTY & KINZELBACH 1988). The results presented here clearly show that this scale effect also exists in karstic conduits.

Tailing effects

OBSERVATIONS

Tailing effects appear very often at certain measurement points (Figure 1). The important tail observed at the station 1 (upstream) is probably due to the injection conditions and to the transfer through the unsaturated zone. As this part of the route cannot be observed directly, it is not considered here. The tail at station 2 is always very reduced, but the apparent dispersivity is always substantially higher than the one in station 1. At station 3, a tail is always observed and at the

exurgence (Saivu, pt 4)), although the major part of the tracings observed have shown no lag, the tracing presented on figure 1 shows a lag which cannot be ignored. Note that, at a given station, the size of the tailing effect is variable from one experiment to another.

	Station 1	Station 1'	Station 2	Station 3	Station 4
Tracing 1	408 m 15 l/s $\alpha=2.7$ $V=26$	1110 m $\alpha=6$ $V=57$		3805 m $\alpha=14$ $V=83$	5173 m $\alpha=26$ $V=106$
Tracing 2	402 m 13 l/s $\alpha=4$ $V=28$	1104 m $\alpha=11$ $V=52$			5167 m $\alpha=26$ $V=73$
Tracing 3		13 l/s 702 m $\alpha=4$ $V=124$			4765 m $\alpha=48$ $V=100$
Tracing 11	203 m 32 l/s $\alpha=20$ $V=21$				4968 m $\alpha=50$ $V=135$
Tracing 12	173 m 30 l/s $\alpha=3$ $V=32$				4838 m $\alpha=5$ $V=157$
Tracing 14	455 m 21 l/s $\alpha=3$ $V=40$	1157 m $\alpha=19$ $V=84$			
Tracing 23	176 m 32 l/s $\alpha=2$ $V=88$			3573 m $\alpha=12$ $V=114$	4941 m $\alpha=14$ $V=174$
Tracing 24	176 m 25 l/s $\alpha=2$ $V=69$			3573 m $\alpha=12$ $V=166$	4941 m $\alpha=25$ $V=143$
Tracing 25	461 m 24 l/s $\alpha=5$ $V=42$		2026 m $\alpha=5$ $V=123$	3858 m $\alpha=19$ $V=132$	
Tracing 40	176 m 30 l/s $\alpha=7$ $V=306$		1741 m $\alpha=17$ $V=229$	3573 m $\alpha=18$ $V=205$	
Tracing 41	40 m 26 l/s $\alpha=1$ $V=200$		1605 m $\alpha=16$ $V=217$	3437 m $\alpha=17$ $V=187$	
Tracing 42	40 m 22 l/s $\alpha=0.4$ $V=44$		1605 m $\alpha=16$ $V=178$	3437 m $\alpha=17$ $V=149$	4805 m $\alpha=24$ $V=161$

Table 1 : Dispersivities (α) in m and flow velocities (V) in m/h measured at different distances along the length of the river's underground course. The dispersivities always increase with the measurement scale (scale effect). The discharge is given at station 1.

TURBULENT FLOW AS A DISPERSIVE PROCESS ?

The flow are turbulent on all the length of the underground stream (JEANNIN & MARECHAL 1996). Can turbulent flow cause the observed tailing effect ?

The existence of turbulent flow zones, downstream from which the theoretical and experimental curves can be fitted perfectly, seems to indicate that the tailing effect is not due to the turbulent flow regime. Further, the station 2, where the tailing effect is always reduced is located after a section of torrential flow.

To confirm this hypothesis, several "micro-tracings" (tracing experiments on sections of a few tens of metres in length) have been carried out. Let us consider the "micro-tracing" (A) depicted on figure 3. It was carried out in a zone 80 metres long, of turbulent torrential flows in a conduit of constant cross section (no major enlargements). The fitting of the experimental curve onto the Sauty model is excellent. This experiment empirically confirms that the turbulent flows are not the cause of the lag effect.

EFFECTS OF THE VARIATIONS IN CROSS-SECTION

The "micro-tracing" (B) was designed to evaluate the effect of an enlargement of the flow cross-section on the dispersion and tailing (figure 3). The tracer was injected upstream of an enlargement (1.5 m deep, 4 m large).

The breakthrough curve just before the enlargement does not show any tailing effect. Next to the outflow of the pool, the curve shows an important tail. The presence of a large and deep cross-section (pool) appears to produce a tailing effect. Other similar experiments have been carried out, all showing the important influence of variations in cross sectional area on tailing effects.

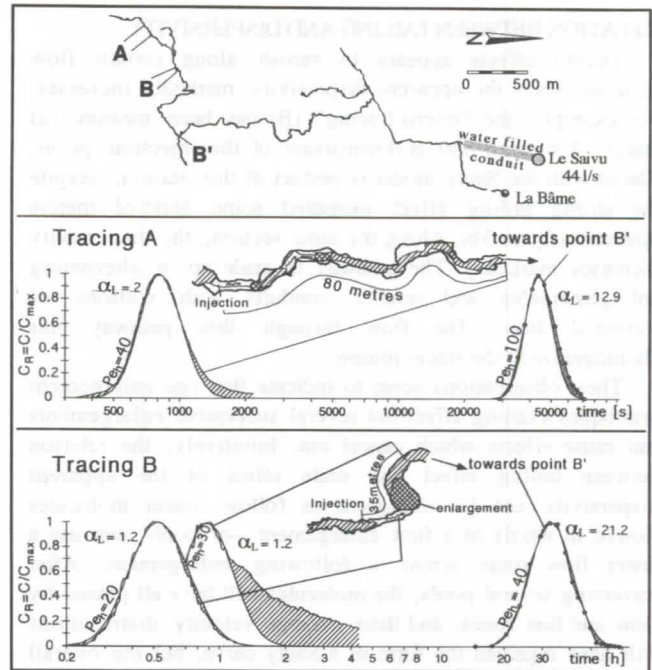

Figure 3 : "Micro-tracings" (A and B) used to measure the effect of certain heterogeneities at a local scale. The tracing A shows that the turbulent flows do not cause any tailing effects. The tracing B shows the importance of the tailing linked to the presence of a big enlargement on the flow path of the tracer. In the two cases, the lag effect has almost disappeared some hundreds metres downstream (point B').

This can be intuitively understood as follow: over a small cross-section, the flow velocity is more or less the same over the whole cross-section; in an enlargement, the flow velocity can be high in the middle and much lower or even reversed (whirlpool) on the edges. Part of the tracer can then be lagged or « trapped » in these longer flow routes.

A simplified numerical model of this effect has been done using a Darcy-flow model with strong variations of the flow cross-section (figure 4). After three enlargments, the breakthrough curve shows an important tailing effect. This model produces qualitatively adequate results, but does not represent a theoretical proof of the conceptual model. Models solving the full Navier-Stokes equations in three dimensions might be used for that (see HAUNS *et al.* 1997).

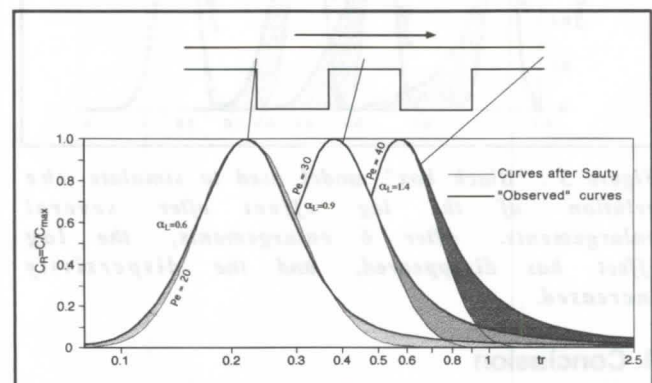

Figure 4: Finite element model of a porous medium with flow cross-section variations. The shape of the breakthrough curve is clearly modified by the presence of enlargements (tailing effect).

RELATION BETWEEN TAILING AND DISPERSIVITY

Tailing effects appears to vanish along certain flow sections where the apparent dispersivity markedly increases. For example, the "micro-tracing" (B) has been measured at station 2 situated 850 m downstream of the injection point. The fit with the Sauty model is perfect at this station, despite the strong tailing effect measured some hundred meters upstream (figure 3b). Along the same section, the dispersivity increases markedly. The pathway is made up of alternating enlargements and smaller conduits with sections of torrential flow. The flow through this pathway has "homogenized" the tracer plume.

These observations seem to indicate that one enlargement provokes a tailing effect but several successive enlargements can cause effects which cancel out. Intuitively, the relation between tailing effect and scale effect of the apparent dispersivity can be considered as follow: tracer molecules slowed in whirls of a first enlargement –or pool– can use a faster flow route across a following enlargement. After traversing several pools, the molecules will have all passed by slow and fast zones, and their average velocity distributions will have regained the form of a Sauty curve, but the overall apparent dispersivity will then be higher.

One can simulate the statistical decrease in the lag effect across several enlargements using a curve of residence time distributions (RTD) of a tracer cloud which has crossed one enlargement (large tailing effect), and then convolve it several times with itself. Figure 5 gives an impression of the form of the breakthrough curve as a function of the number of convolutions (number of pools). After six enlargements, the curve has a form very similar to the theoretical curves of Sauty, the dispersivity measured on the rise of the curve increases from one curve to the next.

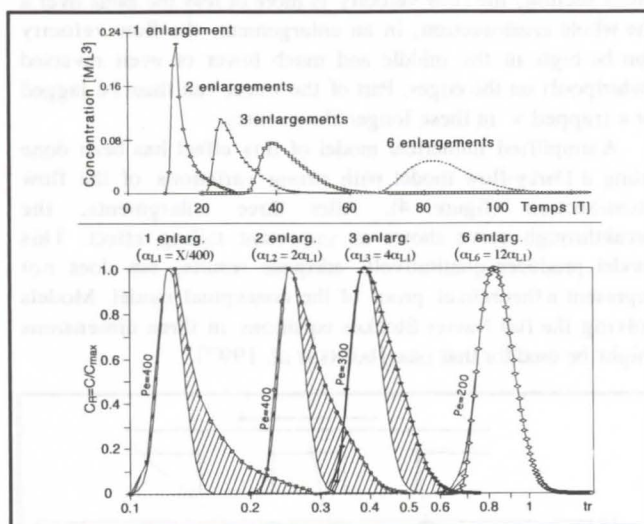

Figure 5 : "Black box" model used to simulate the evolution of the lag effect after several enlargements. After 6 enlargements, the lag effect has disappeared, and the dispersivity increased.

4. Conclusion

The observations made along the length of the underground river Milandrine document the large variability in velocity (between 17.5 and 365 m/h) and dispersivity (between 0.4 and 49.7 metres) of the tracers along the length of their route.

All the experiments carried out allow us to make four observations.

1) A scale effect is associated with the dispersivity measurements which increase with the scale of observation.

2) Turbulent, but regular flows - on a channel of constant cross-section- do not give rise to a measurable tailing effect, the experimental curves obtained at the end of such sections fitting perfectly to the Sauty curves.

3) The presence of a large basin (strong variation of the flow cross-section) causes a clear lag effect. This effect is very probably linked to the strong velocity gradients found inside the basins between slow and rapid zones.

4) The succession of big basins seems to cause an increase in dispersivity and the disappearance of the lag effect: one single basin produces a lag but several successive ones produce effects which cancel out towards the tailing, but produce a substantial increase of the apparent dispersivity.

Tailing effects are seen very often in the breakthrough curves measured at karst springs. They might come from the existence of several independent pathways, from a transient flow regime during the experiment, or from the injection conditions (strong tailing effect between the injection point and the point of arrival in the karst conduits). This paper shows that they might also be produced by strong heterogeneity of the flow cross-section along the karst conduits.

References

- BIVER, P. 1993. Etude phénoménologique et numérique de la propagation de polluants miscibles dans un milieu à porosité multiple. These Sciences Univ. of Liège, Belgium, 389 p.
- DE MARSILY, G. 1986. Quantitative hydrogeology. Groundwater hydrology for Engineers. Academic Press, 440 p.
- HAUNS, M.; HERMANN, F. & ATTEIA, O. 1997. Application of a CFD model to cave river hydrodynamics. This volume.
- JEANNIN, P.-Y. & MARECHAL, J.-C. 1996. Lois de pertes de charge dans les conduits karstiques : base théorique et observations. *Bulletin d'hydrogéologie No 14*, 149-176.
- MALOSZEWSKI, P. & ZUBER, A. 1989. Mathematical models for interpreting tracer experiments in fissured aquifers. In: "The application of isotope techniques in the study of the hydrogeology of fractured and fissured rocks", IAEA: 287-301.
- MARECHAL, J.-C. 1994. Etude et modélisation de l'hydraulique et du transport dans les drains karstiques. Master Thesis in Hydrogeology, Univ. of Neuchâtel, unpublished, 128 p.
- MEUS, Ph. 1993. Hydrogéologie d'un aquifère karstique dans les calcaires carbonifères (Néblon-Anthisnes, Belgique). Apports des traçages à la connaissance des milieux fissurés et karstiques. These Sciences Univ. of Liège, Belgium, 323 p.
- PTAK, T. & TEUTSCH, G. 1994. Forced and natural gradient tracer tests in a highly heterogeneous porous aquifer : instrumentation and measurements. *J. Hydrol.* 159: 79-104.
- ROSSIER Y. & KIRALY L. 1992. Effet de la dilution sur la détermination des dispersivités par interprétation des essais de traçage dans les aquifères karstiques. *Bull. du Centre d'hydrogéologie de Neuchâtel* 11: 1-15.
- SAUTY, J.-P. & KINZELBACH, W. 1988. On the identification of the parameters of groundwater mass transport. In: (E. Custodio *et al.*, ed.), Groundwater flow and Quality modelling: 33-56.
- SAUTY, J.-P. 1977. Contribution à l'identification des paramètres de dispersion dans les aquifères par interprétation des expériences de traçage. These Université scientifique et médicale et Institut National Polytechnique, Grenoble, 157 p.
- SEILER, K.-P., MALOSZEWSKI, P. & BEHRENS, H. 1989. Hydrodynamic dispersion in karstified limestones and dolomites in the upper Jurassic of the Franconian Alb, F.R.G. *J. Hydrol.* 108: 235-247.

Obtaining information on fracture geometry from heat flow data

Rudolf Liedl, Sven Renner, Martin Sauter

Applied Geology, University of Tuebingen, Sigwartstrasse 10, 72076 Tuebingen, Germany

Abstract

In this paper it is shown that changes of water temperature recorded at the outlet of a fracture depend on the spatial structure of the fracture geometry if the discharge is time-variant. This result is used to characterise the geometric properties of a conduit network in a Swabian Alb karst aquifer.

Zusammenfassung

Dieser Beitrag zeigt, daß Änderungen der Wassertemperatur am Ausgang einer Kluft von der räumlichen Struktur der Kluftgeometrie abhängen, sofern ein zeitabhängiger Durchfluß vorliegt. Dieses Ergebnis wird verwendet, um die geometrischen Eigenschaften des Röhrennetzwerks eines Karstaquifers der Schwäbischen Alb zu charakterisieren.

1. Introduction

For modelling purposes fractured aquifers are frequently assumed to consist of two hydraulic systems which are coupled to each other: a network of "large" fractures, e. g. karst conduits, with high flow velocities and low storage, and the rock matrix with slow flow but a comparatively high storage coefficient.

The high vulnerability to contamination of fractured aquifers is mainly a result of the fast transit time of dissolved substances in the fracture network. However, data on these fractures are rare due to the inaccessibility of these pathways. For single fractures BENDERITTER *et al.* (1993) could characterise flow in a carbonate medium by using heat transport data.

In this paper it is shown that unsteady flow conditions, e. g. during recharge events, are necessary in order to get insight into and to obtain quantitative information on the geometry of the fracture system. This approach is applied to a karst catchment in the Swabian Alb (SW Germany). The paper can be regarded as a brief summary of the results achieved by RENNER (1996).

2. Modelling Approach

In order to establish a mathematical heat transport model it is convenient to consider a single fracture first. It is assumed that the fracture geometry can be approximated by a parallel-plate model, i. e.

$$\frac{V}{A} = \frac{\delta}{2} \quad (1)$$

with V volume, δ aperture, and A contact area of the fracture.

According to the conceptual model shown in Fig. 1 heat is transported by convection along the fracture and by conduction in the rock matrix. Conductive heat transfer is modelled by

$$\frac{\partial T_s}{\partial t} = \frac{\lambda_s}{c_s \rho_s} \frac{\partial^2 T_s}{\partial z^2} \quad (2)$$

(CARSLAW & JAEGER, 1959) with T_s temperature in the matrix, ρ_s rock density, c_s specific heat capacity, and λ_s heat conduction coefficient of the matrix. For heat flow in the fracture conductive processes are neglected so that the transport equation can be written as

$$\frac{\partial T_f}{\partial t} + v(t) \frac{\partial T_f}{\partial x} = \frac{\lambda_s}{c_f \rho_f} \frac{A}{V} \frac{\partial T_s}{\partial z}(x, 0, t) \quad (3)$$

(CARSLAW & JAEGER, 1959) with T_f water temperature, c_f specific heat capacity, and ρ_f density of water. In eq. (3) the convective velocity v depends on time because unsteady flow conditions are considered. The right-hand side represents the heat exchange between the fracture and the rock due to the temperature gradient at the surface of the matrix ($z=0$).

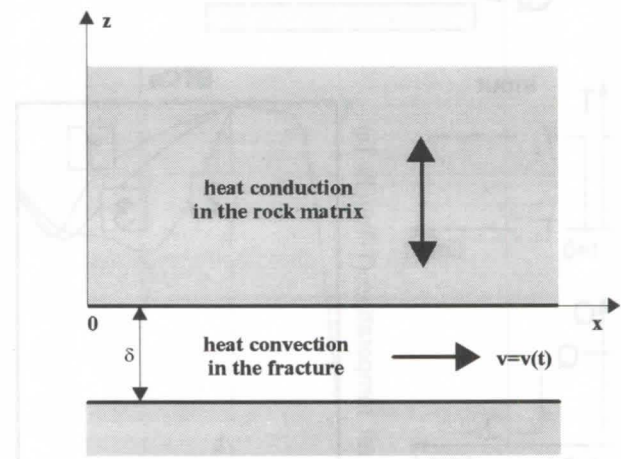

Figure 1: Conceptual model of flow and heat transport in a single fracture with constant aperture

In order to complete the mathematical model appropriate initial and boundary conditions have to be specified. In the rest of this study heat transport problems with initially uniform temperature distributions are discussed, i. e.

$$T_f(x, 0) = T_s(x, z, 0) = T_0 \quad (4)$$

The boundary conditions for the conductive heat flow in the matrix are given by

$$T_s(x, 0, t) = T_f(x, t), T_s(x, +\infty, t) = T_0 \quad (5)$$

The boundary condition at the fracture inlet can be written as

$$T_f(0, t) = T_p(t) \quad (6)$$

In eq. (6) $T_p(t)$ denotes the time-dependent water temperature at the fracture inlet.

RENNER (1996) solves eqs. (1)-(6) numerically using a finite difference technique. His approach also allows for (i) non-uniform fracture apertures, (ii) fracture intersections, (iii) inflow from the vadose zone. With these model extensions the flow velocity in the fracture also depends on x .

3. Parameter Studies

In a first example heat transport is studied for the three fractures shown in Fig. 2 having identical volume and contact area but different apertures (RENNER, 1996). The water temperature at the fracture inlet has a constant value T_p . The flow rate is equal to Q_1 until $t=t_1$, then it drops to $Q_2 < Q_1$. The breakthrough curves (BTCs) at the fracture outlet are identical until $t-V/Q_2=t_1$. For larger times they differ significantly.

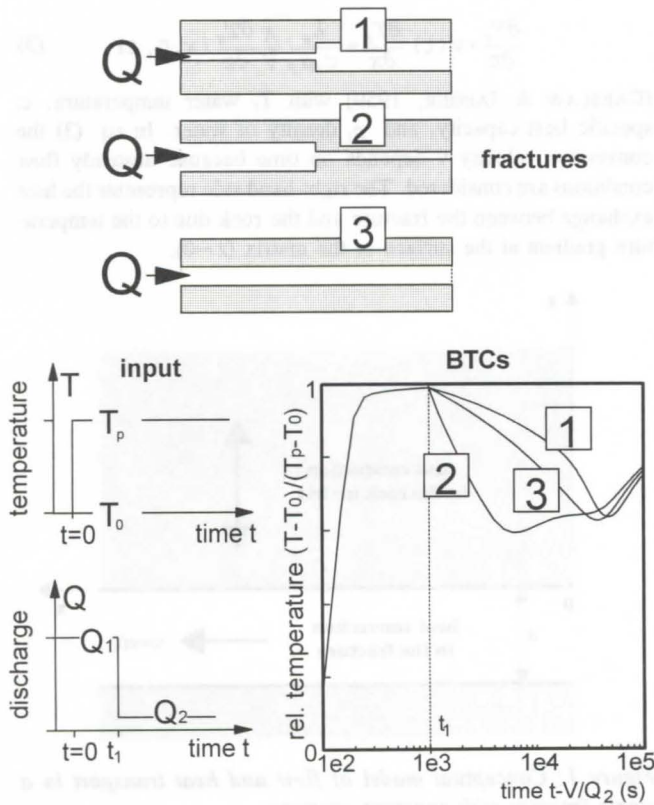

Figure 2: BTCs for three different fractures for time-dependent discharge

In order to explain this behaviour it should be mentioned first that the temperature must decrease after the reduction of the discharge leading to an increase of the residence time of the water in the fracture so that more heat is transferred into the rock matrix. Secondly, the decrease of temperature depends linearly on the surface volume ratio $A/V = 2/\delta$ (eq. (1)). As a result, the temperature decreases more slowly for larger apertures and the BTC of fracture 1 starts to decrease less significantly after $t-V/Q_2=t_1$ because the wider part of fracture 1 is close to the outlet. This reduction of water temperature is enlarged as soon as

water coming from the narrow part of fracture 1 reaches the outlet. For fracture 2, which is a mirror image of fracture 1, the temperature starts to decrease more steeply because in this case the narrow part is close to the outlet. The BTC of the uniform fracture 3 shows an intermediate behaviour. Finally, all BTCs approach a BTC that would have occurred if the discharge had been equal to Q_2 for the whole time.

This example clearly shows that temperature changes of spring waters emerging from fractured and karstified aquifers may reveal information on the fracture geometry only if there is unsteady flow which is likely to occur during recharge events. The non-uniformity of the fracture is rendered by the shape of the BTC.

Next, the importance of fracture intersections is demonstrated (RENNER, 1996). Fig. 3 shows some BTCs for a system of two interconnected fractures which have the same length but different apertures ($\delta_1/\delta_2=1.86$). For an increasing number of intersections it can be seen that the BTC of an "equivalent fracture" with contact area $A=A_1+A_2$ and aperture $\delta=(\delta_1+\delta_2)/2$ is approached.

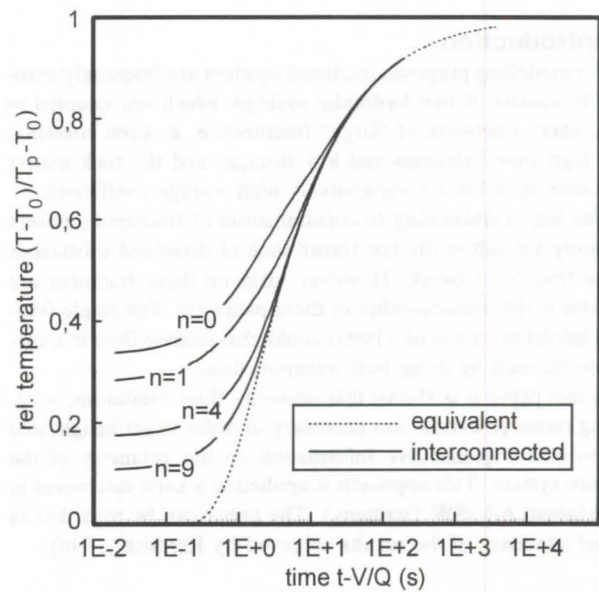

Figure 3: BTCs for two interconnected fractures with n intersections ($n=0, 1, 4, 9$)

It is obvious that an increasing number of intersections must have the same effect on heat flow as a permanent mixing of waters along two parallel fractures and that this system can be represented by a single fracture with equivalent properties. RENNER (1996) presents a similar example showing that an equivalent fracture can also be found for a system of two fractures with the same aperture but different lengths provided that there is a sufficient number of intersections.

4. Application

The approach outlined above is applied to the Gallusquelle catchment which is part of the Swabian Alb karst in SW Germany (Fig. 4). Time series of spring discharge and water temperature exhibit a strong correlation (Fig. 5). A very important feature of the temperature record is that recharge events always lead to a decrease of spring water temperature with respect to the background value of 8.75°C.

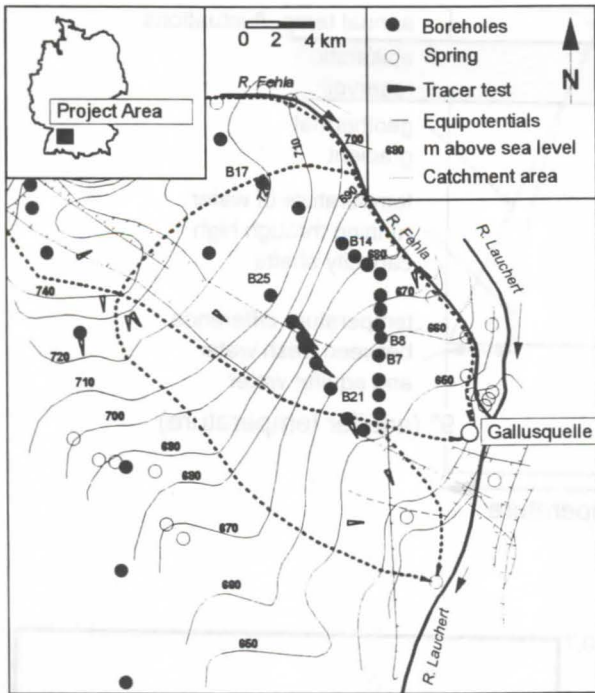

Figure 4: Gallusquelle catchment area (RENNER & SAUTER, 1997)

This observation can be explained by a conceptual model (Fig. 6) which is based on the assumption that there is an epikarstic reservoir with a low vertical permeability (RENNER & SAUTER, 1997). Accordingly, the recharge water remains in this domain long enough to adapt the rock temperature which is about 6°C. Then, the water flows very rapidly through vertical shafts so that there is no temperature equilibration with respect to the geothermic gradient. Reaching the groundwater table the water temperature is always less than 9°C. These temperature differences are found again in the time series shown in Fig. 5. Similar observations are reported by JEANNIN (1990).

A model of heat transport in the aquifer is established by making use of the equivalent fracture approach mentioned at the end of section 3. The fracture geometry is determined by calibrating the model with respect to spring water temperature measured during a recharge event in June 1988 (Fig. 7). It is found that the

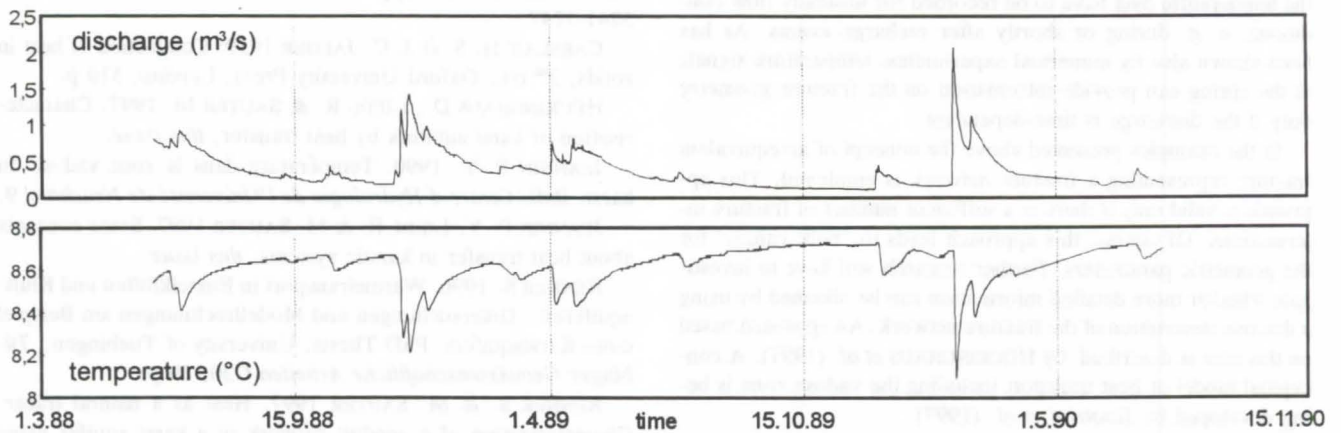

Figure 5: Spring water temperature and discharge at the Gallusquelle karst spring

temperature differences at the spring can be simulated quite accurately by assuming that the equivalent fracture consists of three segments (RENNER, 1996). The volume V , the aperture δ , and the length L of each fracture segment are summarized in Fig. 8.

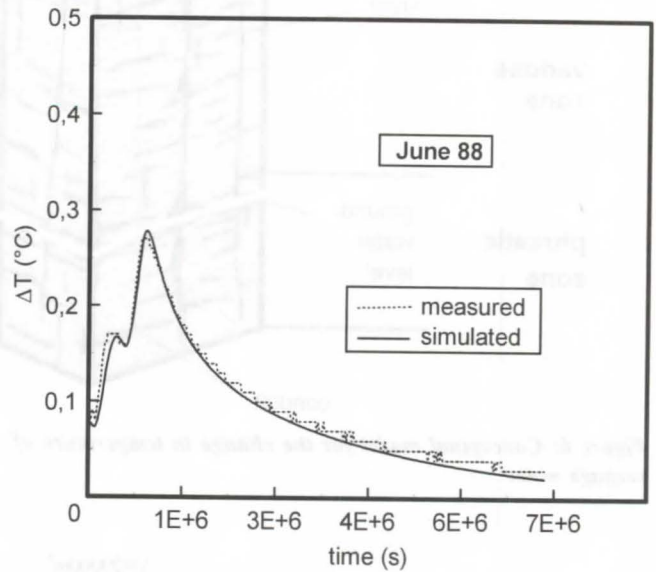

Figure 7: Model calibration with respect to spring water temperature

These parameters are now used in order to simulate spring water temperatures after a recharge event in February 1990. The absolute values of the deviation from the background temperature are shown in Fig. 9 where only the input temperature T_p has been used as a calibration parameter. It can be seen that the model results and the measured values match very well. The slight discrepancy at the peak of the BTC may be attributed to the influence of the fluctuations of the groundwater level which are neglected in the model (RENNER, 1996). Some more examples of model validation, provided by RENNER (1996) and RENNER & SAUTER (1997), also show a close agreement of the simulations and the measurements so that the approximation of a karst conduit system by a single equivalent fracture seems to be justified for this aquifer.

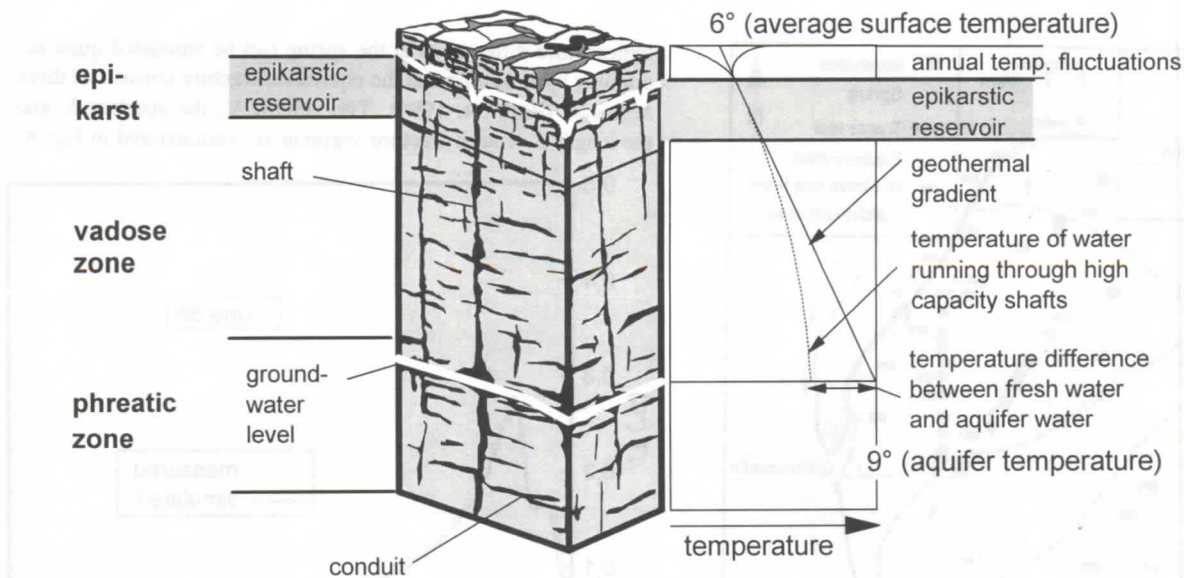

Figure 6: Conceptual model for the change in temperature of seepage water

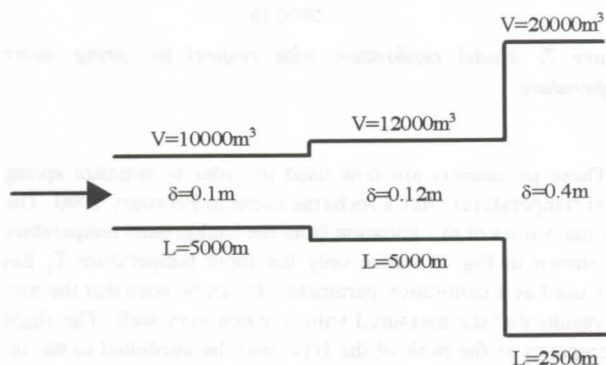

Figure 8: Equivalent fracture for the Gallusquelle karst catchment

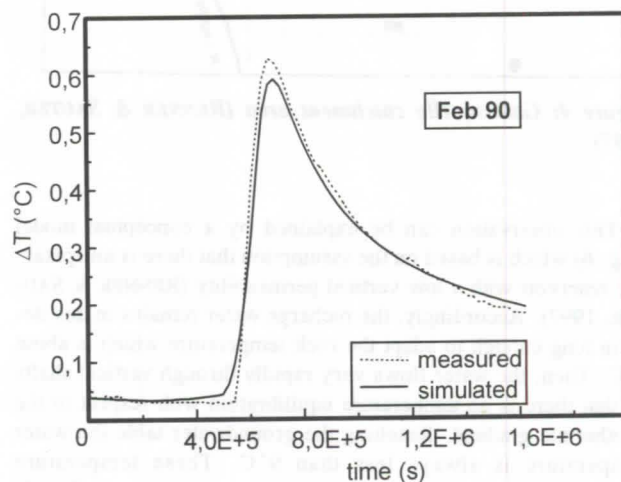

Figure 9: Model validation

5. Summary and Conclusions

It has been demonstrated that the geometrical properties of a karst conduit system in the Swabian Alb can be characterized by analysing spring water temperatures. It is important to note that the temperature data have to be recorded for unsteady flow conditions, e. g. during or shortly after recharge events. As has been shown also by numerical experiments, temperature signals at the spring can provide information on the fracture geometry only if the discharge is time-dependent.

In the examples presented above the concept of an equivalent fracture representing a fracture network is employed. This approach is valid only if there is a sufficient number of fracture intersections. Of course, this approach leads to "bulk values" for the geometric parameters. Further research will have to investigate whether more detailed information can be obtained by using a discrete description of the fracture network. An approach based on this idea is described by HÜCKINGHAUS *et al.* (1997). A conceptual model of heat transport including the vadose zone is being developed by JEANNIN *et al.* (1997).

References

- BENDERITTER Y.; ROY B. & A. TABBAGH 1993. Flow characterization through heat transfer evidence in a carbonate fractured medium: First approach. *Water Resour. Res.* 29 (11): 3741-3747.
- CARSLAW H. S. & J. C. JAEGER 1959: Conduction of heat in solids, 2nd ed., Oxford University Press, London, 510 p.
- HÜCKINGHAUS D.; LIEDL R. & SAUTER M. 1997. Characterisation of karst aquifers by heat transfer, *this issue*.
- JEANNIN P.-Y. 1990. Température dans la zone vadose du karst. *Bull. Centre d'Hydrologie de l'Université de Neuchâtel* 9.
- JEANNIN P.-Y, LIEDL R. & M. SAUTER 1997. Some concepts about heat transfer in karstic systems, *this issue*.
- RENNER S. 1996. Wärmetransport in Einzelklüften und Kluftaquiferen - Untersuchungen und Modellrechnungen am Beispiel eines Karstaquifers. PhD Thesis, University of Tuebingen, *Tübingen Geowissenschaftliche Arbeiten* C30, 89 p.
- RENNER S. & M. SAUTER 1997. Heat as a natural tracer: Characterization of a conduit network in a karst aquifer using temperature measurements of the spring water. *Proceedings of "Karst '95 - Int. Symp. & Field Seminar on Karst Waters & Environmental Impacts"*, Antalya, Turkey, to appear.

Special spring discharge changes in the Aggtelek karst region in Hungary

I. Maucha

Water Resources Research Centre (VITUKI) Plc1095 Kvassai Jenő út 1. Budapest, Hungary

Abstract

The Aggtelek Karst is renowned for the number of its special hydrologic features. The surges of the Lófej spring result from the combined action of three siphon systems. These waves are transferred to, and superimposed upon, as an attenuated pulsation on the yield time series of the similarly siphon controlled Nagy-Tohonya spring. Tidal influences on the fluctuations of karst water table, spring discharges and lithoclase fluctuation were noted with surprise. The influence of surface air temperature variations was also detected in spring discharge fluctuations during the snowmelt period. No specific effects of earthquakes and atmospheric pressure could be identified, but statistical analyses have shown these to play a role in triggering discharge changes. The precipitation-yield correlation was also studied and its mechanism explained as the seventh influence.

Zusammenfassung

Das Aggteleker Karstgebiet ist von vielen speziellen hydrologischen Erscheinungen bekannt. Die Ausbrüche der Lófej-Quelle werden von einem Dreier-Saugheber-System verursacht. Diese Änderungen werden weitergegeben und als gemilderte Pulsation auf der Schüttungs-Zeitreihe der Ausbrüche der auch durch Siphon regulierten Nagy-Tohonya-Quelle superponiert. Es war eine unerwartete Erkennung, dass in der Änderung des Karstwasserniveaus, der Quellschüttung und der sg. Lithoklasen-Fluktuation kann man auch die Gezeiten-Wirkung beobachten. Wir haben auch die Wirkung der Schwankungen der Oberflächentemperatur auf die Quellschüttungsänderungen nachgewiesen in den Tauwetterperioden. Wir konnten die direkte Wirkung des Erdbebens und des Luftdrucks nicht identifizieren, aber haben wir mit statistischen Methoden bewiesen, dass sie spielen eine Rolle in der Auslösung der obigen Schüttungsänderungen. Als siebente Wirkung haben wir die Beziehung zwischen dem Niederschlag und der Schüttung untersucht und ihren Mechanismus geklärt.

1. Introduction

The aim of the present paper is to demonstrate that in the Aggtelek region (Hungary) composed of Triassic limestones and dolomites springs emerge close to each other, in the discharge fluctuations of which the effects of all known or presumed natural factors can be identified.

2. The phenomenon of direct siphon effects

Among the 15 largest recorded springs in the Aggtelek karst region unrelated siphon effects were observed in the discharge fluctuations of the neighbouring Lófej- and Nagy-Tohonya springs, which resulted in the exploration of several, formerly unknown phenomena. The spring yields fluctuate normally between 340 and 6400 m³/min, the water temperatures from 8.5 to 10.8 and 10.4 to 16.0 °C, respectively.

The analysis of the discharge records of the Lófej spring has disclosed the combination of two series-connected large, and a parallel-connected small siphon as the cause of the wide spring yield fluctuations. The conclusions on the functioning of the system were arrived at from a logical interpretation of the changes observed at medium discharges (Fig. 2, time series 4) and were substantiated by actual discharge measurements in a functioning hydraulic model. The steep peaks were traced back to the siphon B (Fig. 1). The declining discharges preceding the peaks were found to occur, when the siphon A starts releasing, filling simultaneously the Siphon B, the system being located on the main stem of the stream feeding the spring. Owing to the developing drawdown, the rapid

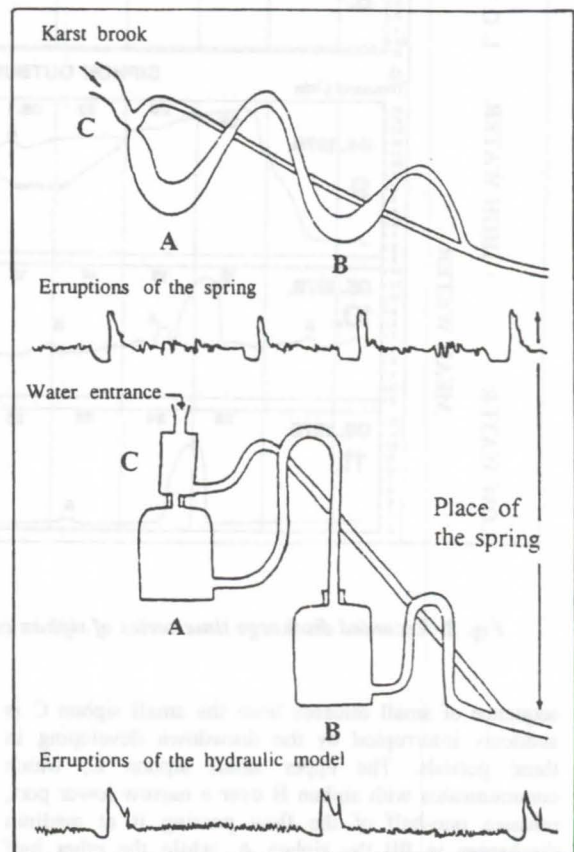

Fig. 1. Conceptual scheme of the three siphons in the Lófej spring (below) and the hydraulic model (above).

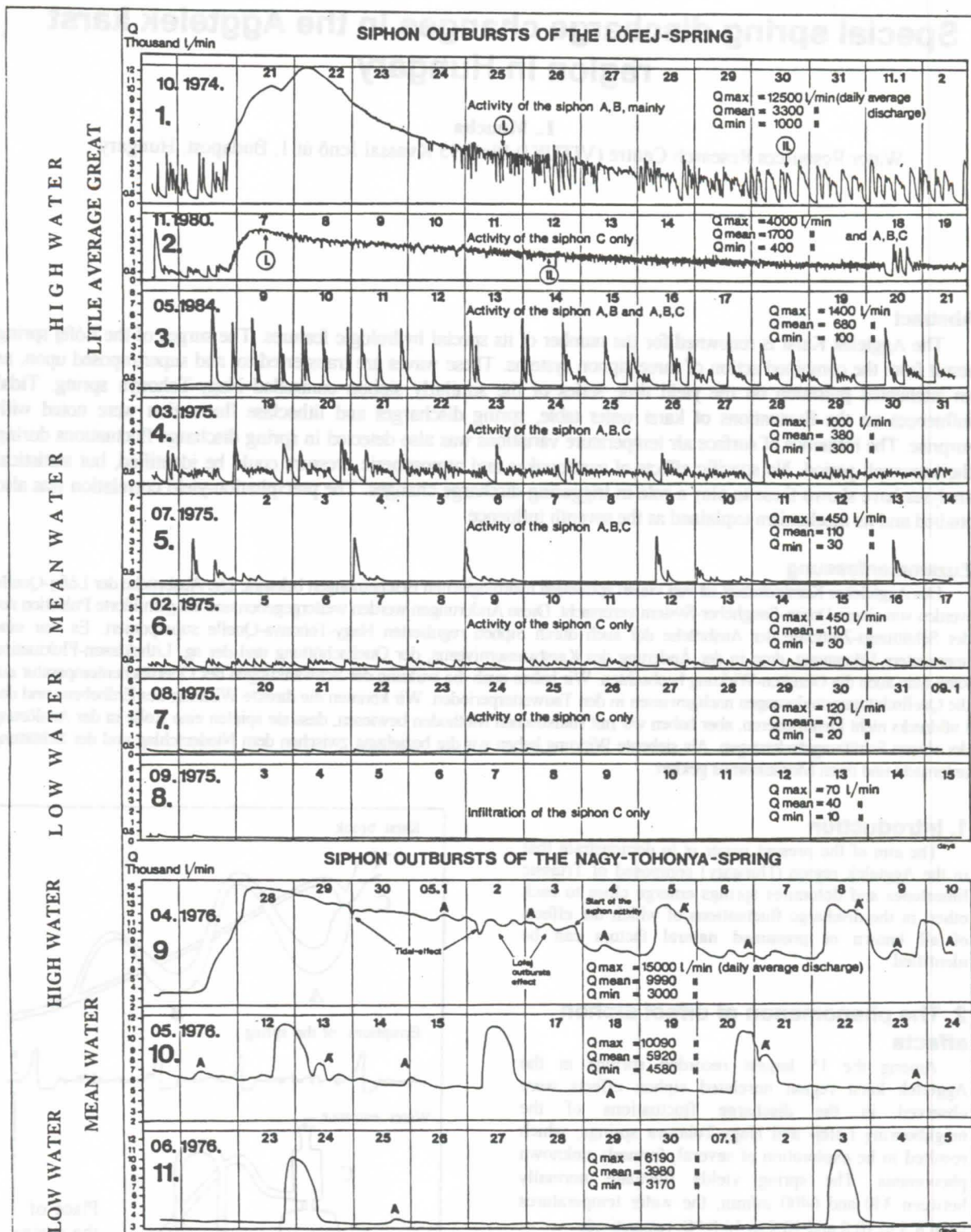

Fig. 2. Recorded discharge time series of siphon controlled springs during highwater, medium and low flows

sequence of small releases from the small siphon C is suddenly interrupted by the drawdown developing in these periods. The upper small siphon C, which communicates with siphon B over a narrow lower port, releases one-half of the flow passing it at medium discharges to fill the siphon A, while the other half backed up by the narrow port is conveyed to the spring in the form of small peaks.

It will be noted in Fig. 2 that the time series 1 is

shaped largely by the operation of the siphons A and B, the time series 2 by that of C, while the first half of the times series 3 again by the siphons A, B. It is of interest to observe that within the same yield range (I-II), after major eruptions the operation of the siphons A, B, whereas after minor eruptions that of C is discernible. The same phenomenon is observed on the time series 5 and 6, where within the same yield range the spring flow is conveyed in the first case by the siphons A, B and C,

while in the second case by the siphon C alone. The cause thereof is the circumstance that the crest of the discharge limb of siphon C is at a lower elevation than in the case of siphon B, which needs a steep increase in flow to trigger release. It is for this reason that at low flows the siphons A, C are full and the water spilling, or leaking over siphon C without release feeds the spring.

The eruptions from the Nagy-Tohonya spring which appear at considerable higher mean flows and discharge volumes larger by one order of magnitude (2500 m^3) are illustrated by the time series 9-11 in Fig. 2. The highest frequency thereof is four releases per week. As implied by the ratio of the measured siphon volume and the spring yield, further by the water temperature drop following the front of the eruption (Gádoros, 1971), the siphon is believed to operate on a by-pass. The higher frequency of eruptions (identified on the Lófej spring) is presumably limited by the circumstance that at higher water levels in the main stem the lateral arm containing the siphon becomes inundated.

3. The phenomenon of indirect siphon effect

Tracer studies and the observations of P. Szilvay alike have provided hydraulic evidence demonstrating that the yield fluctuations of the Nagy-Tohonya spring are affected by the siphon releases of the Lófej spring.

As will be perceived from the time series 9,10 and 11 in Fig. 2, the eruptions of 5-15 hours duration and a few hundred l/s discharge (Δ) follow with an average delay of four hours the eruptions of the Lófej spring. This is illustrated in Fig. 3. The flow diagram of the phenomenon is shown in the upper part of the figure, the lower diagram demonstrating the close correlation between the appearance of the phenomenon considered on the two springs. These pulsations are the strongly attenuated micro-eruptions of the Lófej spring eruptions, which travelled a distance of 3 km and are superimposed on the yield variations of the Nagy-Tohonya spring and are capable of modifying appreciably the hydrograph of the eruptions (Δ). Siphons spaced longer distances apart are capable of influencing the yield changes of karst springs in this way.

4. Tidal phenomena

Statistical analyses have revealed the eruptions to start at 6, 12, 18 and 24 hours with 30 % frequency at both siphon controlled springs mentioned above (Maucha, 1966, 1977 Bartha, 1967). In round moon phases these are the times, when the extreme values of lunisolar changes occur, so that this observation was the first sign implying that tidal effects in underground streams are also involved in triggering yield eruptions. The first assumption was corroborated by the finding that the six-hour tidal fluctuation most frequently registered on non-siphon controlled springs has similar time-statistics (Fig. 4). The six-hour period is impossible to register on the Lófej spring, where the original shape of the yield hydrograph is modified by the siphons.

The existence of the karst tidal phenomenon could be demonstrated by the registered tidal-period fluctuations of the karst water table (Fig. 5 and Gerber,

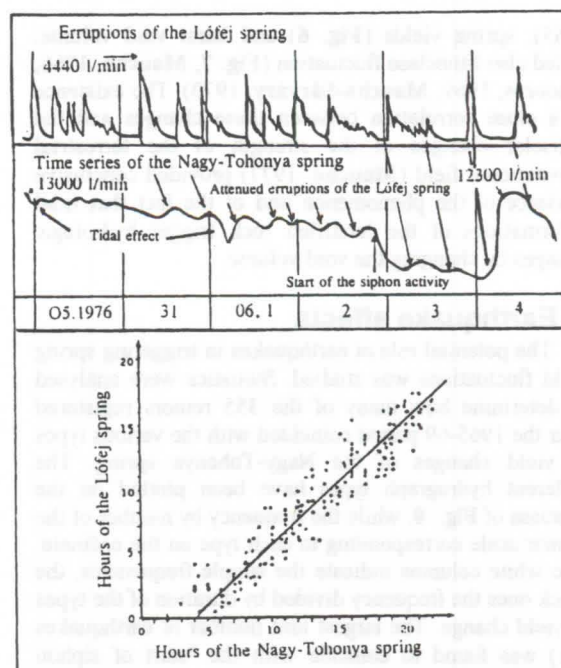

Fig. 3. Correlation between the eruptions of the Lófej spring and the initial times of yield variations of the Nagy-Tohonya spring

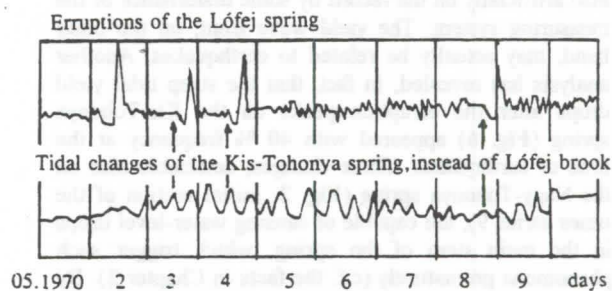

Fig. 4. Starting eruptions on the Lófej spring by tidal variations in the stream filling the siphon. The yield variations of the Lófej spring inaccessible to measurement are replaced by tidal fluctuations of the Kis-Tohonya spring. The potential starting times of siphon release are indicated by arrows.

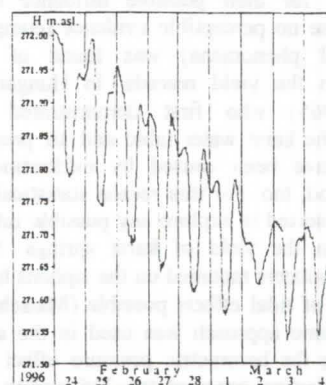

Fig. 5. Tidal fluctuations of the karstwater level in the observation well sunk in dolomite above the Kis-Tohonya spring during February-March, 1996

1965), spring yields (Fig. 6) and karst void volume, called also lithoclase fluctuation (Fig. 7, Maucha, 1966, Gádoros, 1969, Maucha-Sárváry, 1970). The existence of a close correlation between these changes and the lunisolar changes in the strength of the terrestrial gravitational field (Maucha, 1977) provided conclusive evidence of the phenomenon and of the fact that tidal deformations of the karstified rock trigger hydrologic changes by changing the void volume.

5. Earthquake effects

The potential role of earthquakes in triggering spring yield fluctuations was studied. Statistics were analysed to determine how many of the 355 tremors registered over the 1965-69 period coincided with the various types of yield changes of the Nagy-Tohonya spring. The different hydrograph types have been plotted on the abscissa of Fig. 8, while the frequency by number of the tremor scale corresponding to each type on the ordinate. The white columns indicate the simple frequencies, the black ones the frequency divided by duration of the types of yield change. The largest unit number of earthquakes (21) was found to coincide with the "start of siphon activity" (Fig. 8, time series 9) water yield oscillations period (14) and peak yields (5). Of these only the first, conspicuous frequency has been adopted as reliable, in that level oscillations and peak yields can be produced also artificially on the record by some disturbance of the measuring system. The yield wave front, on the other hand, may actually be related to earthquakes. Another analysis has revealed, in fact, that the steep tidal yield drops after the eruption peaks on the Kis-Tohonya spring (Fig. 6) appeared with 40 % frequency at the time of earthquakes. These changes, detectable also on the Nagy-Tohonya spring (Fig. 2, initial section of the times series 9), are capable of causing water-level drops in the main stem of the spring, which trigger such phenomena prematurely (c.f. the facts in Chapter 2). By relieving suddenly the tensile stresses built up on the rising limb of the tide, the earthquakes increase the void volume in the karstic rock, the yield drop induced thereby triggering siphon activity.

6. Atmospheric pressure effects

The variations in atmospheric pressure have also been studied for their possible influence on spring yields, because no perceptible evidence (comparable to that of tidal phenomena) was found of 2-7 day fluctuation in the yield records. In Hungary it was Gerber, (1965) who first demonstrated opposite variation of the karst water table and air pressure, but this could have been caused by infiltration in low pressure period, too. For this reason statistical analyses were again resorted to explore any possible influence of this effect on the yield of karst springs. Since the sensitive transducers mounted on the siphons have made the detection of tidal effects possible (Maucha, 1970), so that the same approach was used in the attempt at demonstrating the barometric pressure effect. For this purpose the starting times of the 216 siphon triggered eruptions of the Nagy-Tohonya spring over the period 1965-69 were checked for the frequency at which these coincided with the diverse phases of the barometric change periods. In Fig. 9 the abscissa show the phases of the full period of barometric pressure change, the ordinates the frequency scale of occurrence. Two distributions are presented in the column diagram, the

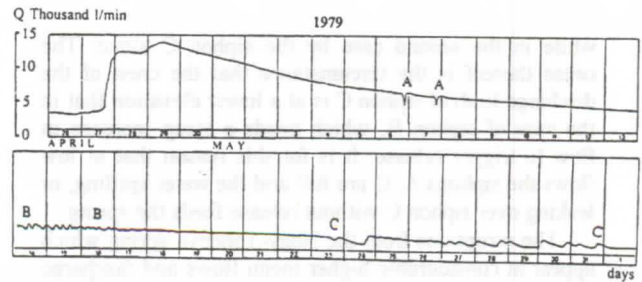

Fig. 6. Tidal yield fluctuation observed regularly in the Kis-Tohonya spring on the recession limb of eruptions. A-A: steep yield drops, B-B: app. 6-hour fluctuation, C-C: yield fluctuation towards the end of the eruption (April, May, 1979)

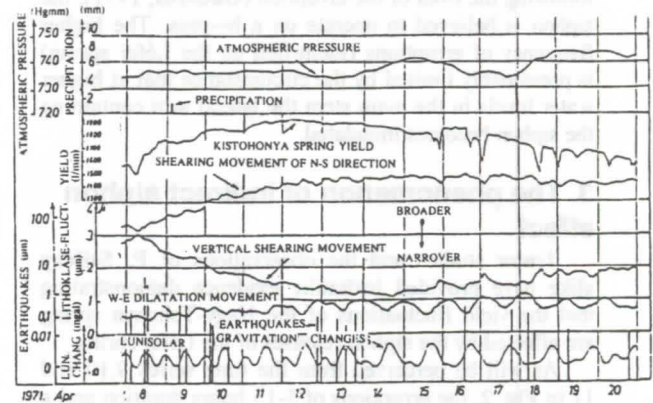

Fig. 7. Lithoclase fluctuation registered in the Vass Imre cave. The time series are following: Atmospheric pressure, precipitation, Kis-Tohonya spring yield, shearing movement of N-S direction, vertical shearing movement, W-E dilatation movement, earthquakes, lunisolar gravitation changes. (April, 1971)

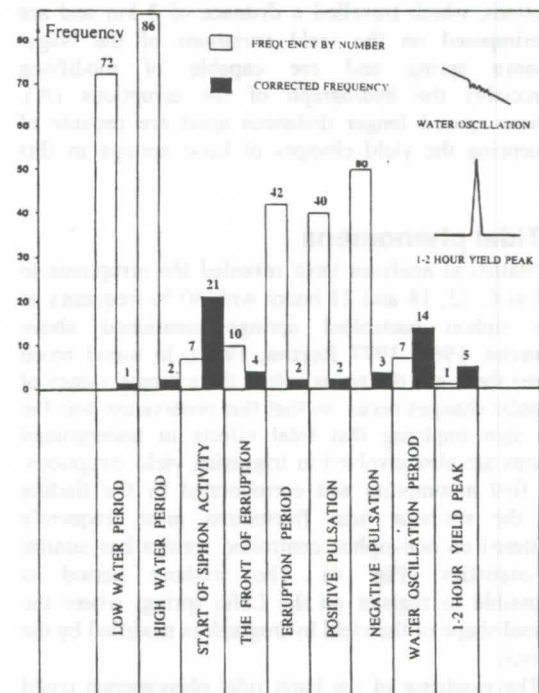

Fig. 8. Earthquake frequency during periods of different types of yield change of the Nagy-Tohonya spring (1965-1969)

full line being the frequency distribution of all eruptions, the dashed line that of the 35 eruptions in the winter period at temperatures below the freezing point. The second is considered relevant, in that it does not include the effect of infiltration caused by rains falling in low pressure periods. The changes in atmospheric pressure were thus found to influence the yield of karst springs, in that the highest eruption frequency was found in the periods of steepest pressure drop around the point of counterflexure. In the total distribution 20 %, in the sub-zero distribution 43 % of the eruptions were noted in these periods at the 10-11-12 phase values.

The result obtained for the infiltration-free period is comparable to that arrived at by Gerber. Moreover, on a single occasion we have succeeded in registering also the lithoclase change caused by a rapid pressure drop immediately before a storm. In this case the pressure drop was found to increase the void content, decreasing the spring yield. This is believed to imply that changes in atmospheric pressure induce changes in the spring yield by changing the volume of voids (lithoclase-fluctuation). The only safe conclusion is, however, that the air pressure effect is capable of triggering syphon release even in periods without infiltration.

7. Air temperature effects

During snowmelt periods daily spring yield fluctuations (24-hour period) were repeatedly observed. The phenomenon occurred during anticyclone (high-pressure) periods, when infiltration caused by snowmelt around noon is interrupted by freezing during the night. A typical sequence of these cycles is illustrated in Fig. 10, the days figuring on the abscissa, the scales of the corresponding time series on the ordinate axis. The upper two curves indicate the variations in air temperature and the reduction of snow cover thickness at the nearby Jósvald meteorological station. The lower two curves are the time series of karst water table and the yield in the water system of the Nagy-Tohonya spring.

8. The rainfall effect

The analysis spring yields has raised the question of the mechanism by which the precipitation falling is transformed into spring yield. Relying on these studies, the actual spring yield is interpreted as the cumulative sum of the discharge time series of eruptions originating from rainfall groups (in winter snowmelt) during the antecedent months and subject to different influences. The major factors involved in the development of eruptions are: 1. the infiltration percentage ($I_0\%$), which varies seasonally as a result of changes in air temperature and vegetation cover, 2. the per cent deviation from the normal mean ($S_0\%$) of karst saturation during the period preceding the particular rainfall group and 3. the per cent decrease ($D_0\%$) of the peak yield caused by depletion up to the day of the yield under consideration.

A simple method of taking into account the major factors influencing the precipitation effect is illustrated in Fig. 11. The depths of the rainfall groups (in mm units) during the two months preceding the day of the spring yield considered are reduced by the foregoing percentages, than summed up. The resulting sum is termed the precipitation effect index P_e . The pairs of index numbers and spring yields considered were used to plot the correlation points of the diagram shown. For

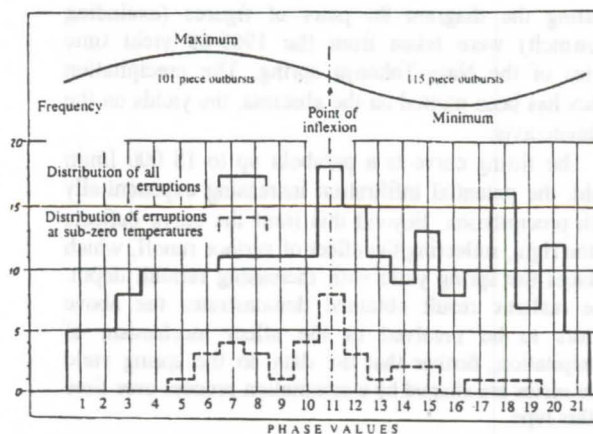

Fig. 9. Frequency of eruptions on the Nagy-Tohonya spring during different phases of atmospheric pressure change (1965-1969)

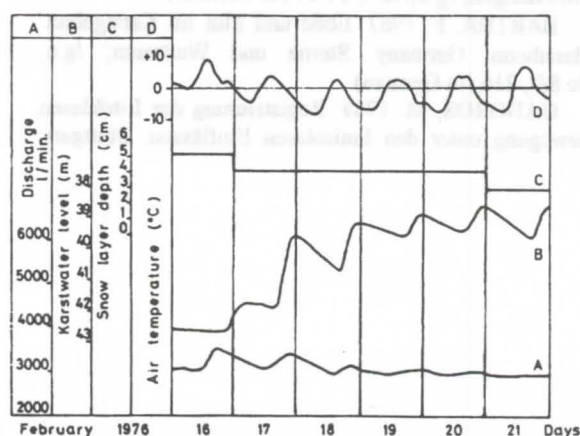

Fig. 10. Influence of air temperature on the karst water table and spring yield in the Nagy-Tohonya spring system (February, 1976)

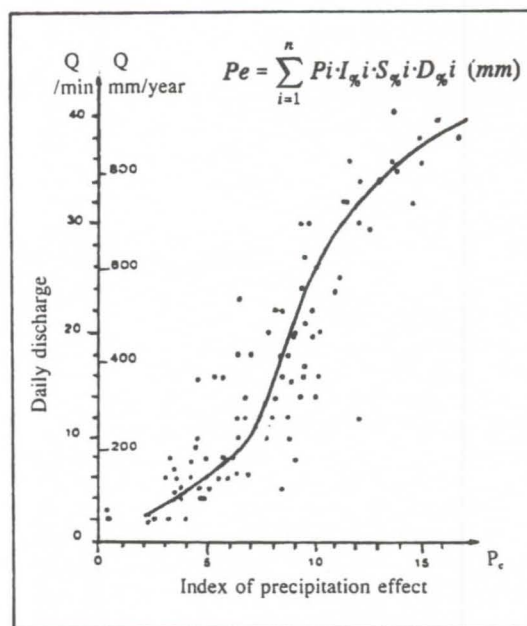

Fig. 11. Correlation between the daily spring yields the precipitation effect index in the case of the Nagy-Tohonya spring (1965-1969)

plotting the diagram 80 pairs of figures (excluding snowmelt) were taken from the 1965-69 yield time series of the Nagy-Tohonya spring. The precipitation index has been plotted on the abscissa, the yields on the ordinate axis.

The fitting curve is a parabola up to 18 000 l/min yield, the potential infiltration increasing exponentially with precipitation. Beyond this limit the curve deflects to the right, reflecting the effect of surface runoff, which reduces the spring yield with increasing rainfall depth. The realistic result obtained demonstrates the above factors to be involved in the effect mechanism of precipitation, further that the data on the spring yield time series are shaped by a summation process over time of this type.

Literature

ANKER, T. F. 1962. Über intermittierende und pulsierende Karstwasserläufe. Munich, Germany. Mitteilungen, Jg 8, No.3, 64-67 (in German)
 BARTHA, F. 1967. Ebbe und Flut im Karstgebiet. Mannheim, Germany. Sterne und Weltraum, Jg.6, No.8/9, 216 (in German)
 GÁDOROS, M. 1969. Registrierung der Litoklassen Bewegung unter den lunisolaren Einflüssen. Stuttgart,

Germany. Int. Konf. of Spel., S.42/1-4 (in German)
 GÁDOROS, M. 1971. A complex investigation of the Nagy-Tohonya spring of Jósvald. Budapest, Hungary. Karszt és Barlangkutatás, Vol VI. 97-102 (in Hungarian)
 GERBER, P. 1965. Observations on karst hydrology in the western horst of the Tatabánya Basin. Budapest, Hungary. Proc. V. Bányavizvédelmi Konf. 74-95 (in Hungarian)
 KESSLER, H. 1956. Studies on spring hydrology in the Aggtelek karst region. Budapest, Hungary. VIITUKI Proc., 1955, 134-152 (in Hungarian)
 MAUCHA, I. 1966. First observations on lithoclase fluctuation in the Vass Imre cave. Budapest, Hungary. Karszt és Barlang, II 82 (in Hungarian)
 MAUCHA, I. 1970. Über die Karstsaugheber als hydraulische relais. Skopje, Yugoslavia. Proc. Congr. Jug. de Spel. 113-123 (in German)
 MAUCHA, I. 1977. Study of tidal movements of karst water and karst rocks. Paris, France. Annales de Geophysique. Tom.33, 151-156 (in English)
 MAUCHA, I. - SÁRVÁRY, I. 1970. Tidal phenomena in the karstic water level. Gentbrugge, Belgium. Bull. of Int. Ass. of Sci. Hydr. 39-47 (in English)



Fig. 10 Influence of the precipitation on the karst water table and spring yield in the Nagy-Tohonya spring (1965-1969)

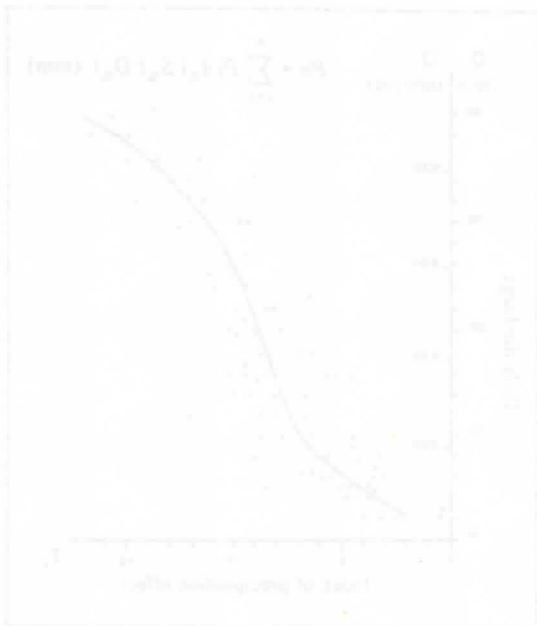

Fig. 11 Correlation between the spring yield and precipitation effect index in the Nagy-Tohonya spring (1965-1969)

Parameter identification in double-continuum models applied to karst aquifers

U. Mohrlök*, J. Kienle, G. Teutsch

Applied Geology, Geological Institute, University of Tübingen, Germany

Abstract

One modelling approach which proved successful in describing the groundwater flow within karst terrains is based on the double-continuum concept. This concept was first introduced by TEUTSCH (1988) and subsequently used by TEUTSCH & SAUTER (1991), SAUTER (1992), LANG (1995), MOHRLÖK (1996) and others to describe the ambivalent characteristics of karst aquifers. However, the approach has the drawback that the double-continuum model parameters can be determined only through model calibration (inverse approach), i.e. so far the model parameters cannot be related directly to physical field measurements. Therefore, in order to develop a better understanding of the physical significance of hydraulic parameters within double-continuum systems, a detailed numerical modelling study was conducted. For this purpose a number of synthetic but realistic karst aquifer network geometries were generated and analysed. The response of the karst network to recharge events was simulated using a detailed discrete fracture flow model with the resulting head and spring flow variographs being subsequently assumed as field measurements. This 'measured' data was then used for the calibration of a double-continuum model and the resulting parameters were compared to the original karst network geometry data. This comparison was used to develop mathematical/physical relationships between the discrete karst network geometry representing reality and the double-continuum parameter representation of it.

Kurzfassung

Ein bisher erfolgreicher Weg zur Quantifizierung der Grundwasserströmung in Karstgebieten ist unter dem Stichwort Doppel-Kontinuum Ansatz bekannt geworden. Dieser Ansatz wurde zuerst von TEUTSCH (1988) eingeführt und anschließend von TEUTSCH & SAUTER (1991), SAUTER (1992), LANG (1995), MOHRLÖK (1996) und anderen dazu verwendet, den ambivalenten Charakter der Grundwasserströmung in Karstaquiferen zu beschreiben. Leider können dabei die Modellparameter jedoch nur durch Kalibrierung (Inversmodellierung) ermittelt werden und sind somit sehr schlecht mit den im Gelände tatsächlich ermittelten Parametern korrelierbar. Um dieses Problem zu lösen, wurde im Rahmen eines Forschungsvorhabens eine detaillierte numerische Simulationsstudie durchgeführt, bei der ein synthetischer, aber realitätsnaher Karstaquifer einschließlich des Karströhrennetzwerks generiert und analysiert wurde. Das Ansprechen dieses synthetischen Karstsystems auf Niederschlagsereignisse wurde unter Verwendung eines diskreten Kluftmodells simuliert und die sich dabei ergebenden Grundwasserstands- und Quellabflußganglinien als im Feld gemessene Werte betrachtet. Diese 'gemessenen' Größen wurden anschließend zur Kalibrierung eines Doppel-Kontinuum Modells verwendet und die dabei ermittelten Werte mit den Ausgangsgrößen, d.h. der Karst-Netzwerkgeometrie, verglichen. Dieser Vergleich diente dazu, mathematisch/physikalische Beziehungen zwischen dem diskreten Karstnetzwerk und den Doppel-Kontinuum Parametern zu entwickeln.

1. Introduction

Frequently the hydraulic properties of karst aquifers can be approximated assuming (a) a lower permeability fissure system with a high storage capacity which is drained by (b) a high permeability but low storativity conduit network. This simplified dualistic view of a karst system can be supported through observations of well and spring hydrograph behaviour, which frequently exhibit two major response frequencies to recharge input - a fast event response and a slow seasonal variation. The simplest way to mathematically represent groundwater flow within such a system is the double-continuum approach, where the fissure system as well as the conduit network are represented by a continuum each (TEUTSCH, 1988). Even though the concept of a representative elementary volume (REV; BEAR, 1972) may not be applicable for the conduit network within smaller catchments, the characteristic hydraulic features of several karst catchments on the Swabian Alb plateau in Southern Germany could be adequately reproduced using double-continuum models (TEUTSCH, 1988; SAUTER, 1992). However, the drawback of this approach is that the double-continuum model parameters cannot be directly related to the geometry and hydraulic conductivity of the karst system, which means that these parameters cannot be

directly derived from field measurements but need to be obtained through model calibration (inverse approach).

In order to develop a better understanding for the physical meaning of the double-continuum model parameters and to improve the prediction capability of the models, a detailed numerical analysis was performed.

Due to the impracticability of a detailed karst geometry analysis at catchment scale, a synthetic karst system network was used as a reference system to represent reality. The hydraulic response of this synthetic karst system to recharge events was calculated using a discrete numerical model which represented in detail the karst network geometry. The resulting well heads and spring hydrographs were subsequently treated as 'measured' field data. Consequently, this data was then used as calibration target for the double-continuum model.

The calibration itself was performed in two steps. First, under steady state conditions, a single-continuum model was used to fit the piezometric head surface, which was obtained through interpolation based on a set of measurement points (boreholes). The resulting transmissivity distribution was then normalised to a base value and a spatially variable multiplier. Second, the double-

* now at the Institute for Hydromechanics, University of Karlsruhe, Germany

continuum model was calibrated under transient conditions using the previously determined transmissivity multipliers, leading to spatially variable storage and exchange coefficients.

2. Synthetic karst system

Approach

Within a discrete karst conduit network, the turbulent groundwater flow can be described by the non-linear Darcy-Weisbach equation:

$$v_c^2 = \frac{2g}{\lambda} d \nabla h_c \quad (1)$$

v_c is the flow velocity, d the diameter, h_c the piezometric head in the conduit, g the acceleration due to gravity and λ a friction coefficient of the conduit.

For the fissure system, the assumption is made that a REV based continuum approach may be applicable. Hence, the flow in the fissured system may be represented through a standard porous media groundwater flow equation (here in 2D):

$$T_f \nabla^2 h_f = S_f \frac{\partial h_f}{\partial t} - N_f \quad (2)$$

T_f is the transmissivity, S_f the storage coefficient, h_f the piezometric head of the fissure system and N_f the recharge to the fissure system.

The exchange flux q_{ex} between the conduits and the continuum is defined by:

$$q_{ex} = -K_f \frac{A_{ex}}{V_{tot}} \nabla h_f \Big|_{x_f = x_c} \quad (3)$$

K_f is the hydraulic conductivity of the fissured system, A_{ex} represents the interfacial area between the conduit and the fissured system, V_{tot} is the bulk volume of the adjacent fissured block and ∇h_f stands for the hydraulic gradient still within the fissured system but at the interface ($x_f = x_c$).

The numerical calculations were performed using the finite-element code ROCKFLOW (WOLLRATH *et al.*, 1991).

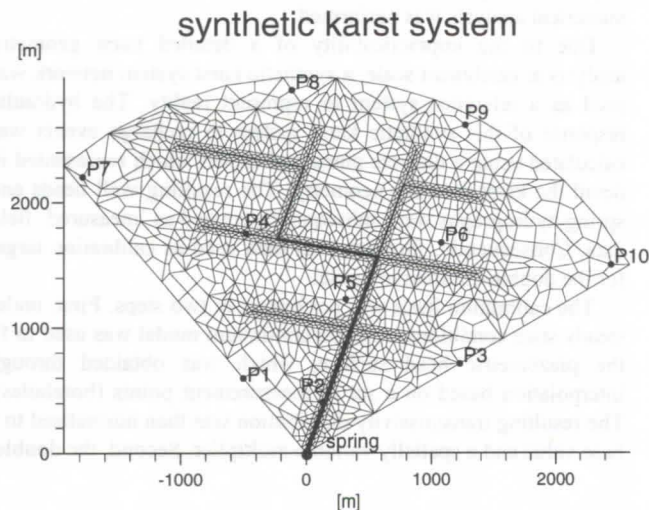

Figure 1: Discretisation of the synthetic karst system and positions of the measurement points.

Discrete model

The design of the synthetic karst system was based on the assumption of a dendritic conduit network. This type of karstification has been postulated for numerous karst catchments on the Swabian Alb carbonate plateau. It is believed to develop where a continuous hydraulic outflow control, e.g. through a spring or a river, exists over a long period of time. The parameters used for this synthetic karst study are equivalent to those determined for the 'Gallusquelle' catchment area (SAUTER, 1992; KIENLE *et al.*, 1997). Only the shape of the catchment area and some details of the conduit network geometry were simplified (Fig. 1). The recharge time series was calculated based on climatic data from the 'Gallusquelle' catchment.

The relation to reality of the synthetic karst system is demonstrated by comparing the characteristics of the spring discharges of the synthetic karst system and the 'Gallusquelle', both calculated with a discrete numerical approach (Fig. 2). The latter represents quite well the observed spring discharge (Fig. 2a).

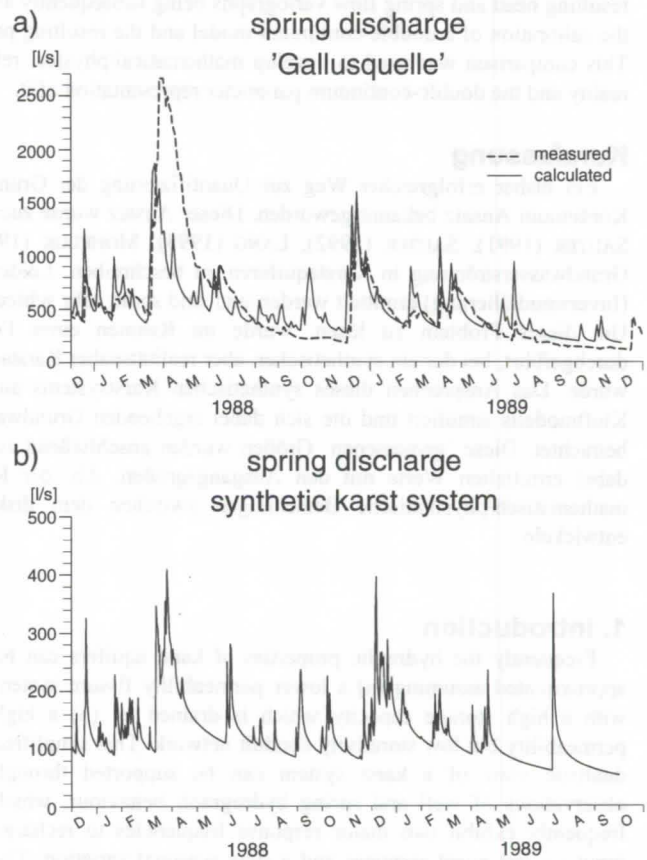

Figure 2: a) Observed and computed spring discharge at the 'Gallusquelle' (KIENLE *et al.*, 1997); b) computed spring discharge for the synthetic karst system.

3. Double-continuum model

Approach

In the double-continuum model approach, it is assumed that the two continua which represent the fissures and the conduit network, overlap each other indistinguishable. Groundwater flow is described in both continua using Darcy's law (TEUTSCH, 1988):

$$\begin{aligned} T_1 \nabla^2 h_1 &= S_1 \frac{\partial h_1}{\partial t} - N_1 + q^*_{ex} \\ T_2 \nabla^2 h_2 &= S_2 \frac{\partial h_2}{\partial t} - N_2 - q^*_{ex} \end{aligned} \quad (4)$$

T_1 and T_2 are the transmissivities, S_1 and S_2 the storage coefficients, h_1 and h_2 the piezometric heads and N_1 and N_2 the recharge for the respective continuum. The exchange flux q^*_{ex} between the two continua is determined based on a steady-state exchange coefficient α and the piezometric head difference (BARENBLATT *et al.*, 1960):

$$q^*_{ex} = \alpha (h_1 - h_2) \quad (5)$$

The double-continuum concept has been implemented as an extension to the well-known numerical code MODFLOW (MCDONALD & HARBAUGH, 1984).

Calibration

For the synthetic karst system an equivalent double-continuum model was calibrated using a two step procedure. First, a single-continuum model was calibrated under steady-state conditions. Then, the double-continuum model was calibrated under transient conditions.

For the steady-state calibration, the 'measured' piezometric head surface was interpolated based on the available borehole locations (comp. Fig. 1). These borehole locations were selected without prior knowledge of the location of the conduit network. The heads at the borehole locations were calculated using the previously described discrete model which represents the synthetic karst system.

The interpolated piezometric surface was then used as the calibration target for the steady-state single-continuum model, which leads to the transmissivity distribution described in Figure 3. The minimum transmissivity obtained for the catchment area was $8.0 \cdot 10^{-4} \text{ m}^2/\text{s}$, which is what was defined as the so called base level transmissivity. The other (higher) transmissivity values within the catchment were normalised to this base level, i.e. leading to a multiplier factor (>1).

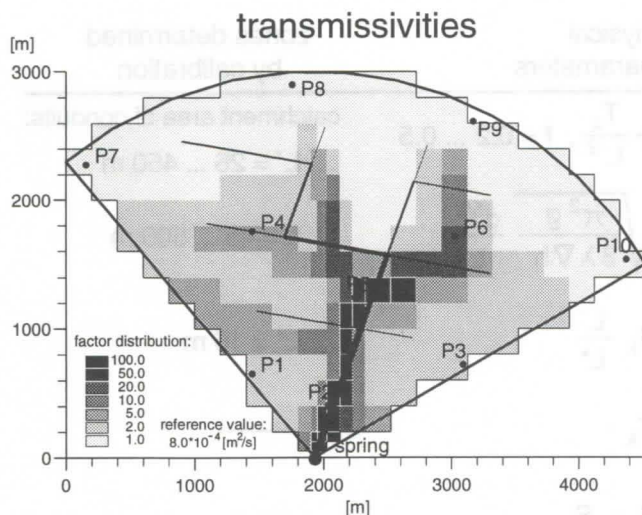

Figure 3: Transmissivity distribution of the single-continuum model.

In a second step, the transient calibration of the double-continuum model was performed keeping the transmissivity multipliers constant and adapting the base level transmissivity only. This calibration strategy proved successful and was used to calibrate also the exchange coefficients. For the calibration of the storage coefficient the square roots of the multiplier values were used.

The results of the calibration procedure are shown in Figure 4. It is seen that the 'measured' spring discharge from the discrete model representing the synthetic karst system can be fitted very

well by the double-continuum model. Similarly, the 'measured' piezometric head time series were fitted for the pre-defined borehole locations. It is interesting to note that the quality of fit to one of the two continua depends mostly on the distance between the observation point (borehole) and the next conduit. For instance, at the borehole location P4, which is located close to a conduit, the 'measured' data fits well the head hydrograph representing the conduit continuum (Fig. 4). Whereas, at the borehole location P1, which is located far from the next conduit, the 'measured' data fits nicely the head hydrograph representing the fissure continuum (Fig. 4).

4. Results

The quality of fit of the spring and well hydrographs to the 'measured' data originating from the synthetic karst system show that double-continuum models may well reproduce the observed ambivalent features of karst systems. Since the 'true' geometric and hydraulic parameters are perfectly known for the synthetic karst system, a set of functional relationships could be derived between those and the double-continuum parameters obtained through model calibration. These relationships are summarised in Tabel 1.

The transmissivity of the conduit continuum is determined by a zone L with an equivalent flux compared to the respective conduit (Fig. 3). The relationship for the exchange coefficient is derived by the approximation of the hydraulic gradient in the fissure continuum adjacent to the conduit. The width L' of the catchment area of a single conduit determines mainly the relationships for these two parameters. The storage coefficient of the conduit continuum is determined by a part of the continuum block representing the catchment area of a single conduit. This part with width L^* shows a similar hydraulic response as the conduit. A more detailed discussion of the relationships described in Tabel 1 is given by MOHRLOK (1996).

References

- BARENBLATT, G. E., ZHELTOV, I. P. & I. N. KOCHINA. 1960. Basic concepts in the theory of the seepage of homogeneous liquids in fissured rocks. *J. Appl. Math. Mech.* (USSR): 1286-1303.
- BEAR, J. 1972. Dynamics of fluids in porous media. Elsevier, New York, 764 p.
- KIENLE, J., MOHRLOK, U. & G. TEUTSCH 1997. Beschreibung der Grundwasserströmung im Einzugsgebiet der Gallusquelle (Schwäbische Alb) mit Hilfe eines diskreten Modellansatzes. *in prep.*
- LANG, U. 1995. Simulation regionaler Strömungs- und Transportvorgänge in Karstaquiferen mit Hilfe des Doppelkontinuum-Ansatzes: Methodenentwicklung und Parameterstudie. PhD-thesis, Institute for Hydraulics and Groundwater, University of Stuttgart, 179 p.
- MCDONALD, M. G. & A. W. HARBAUGH 1984. A modular three-dimensional finite-difference groundwater flow model. USGS, Reston, 527 p.
- MOHRLOK, U. 1996. Parameter-Identifikation in Doppelkontinuum-Modellen am Beispiel von Karstaquiferen. PhD-thesis, *Tübinger geowissenschaftliche Arbeiten C31*, 125 p.
- SAUTER, M. 1992. Quantification and forecasting of regional groundwater flow and transport in a karst aquifer (Gallusquelle, Malm, SW. Germany). PhD-thesis, *Tübinger geowissenschaftliche Arbeiten C13*, 150 p.
- TEUTSCH, G. 1988. Grundwassermodelle im Karst: Praktische Ansätze am Beispiel zweier Einzugsgebiete im Tiefen und

spring discharge

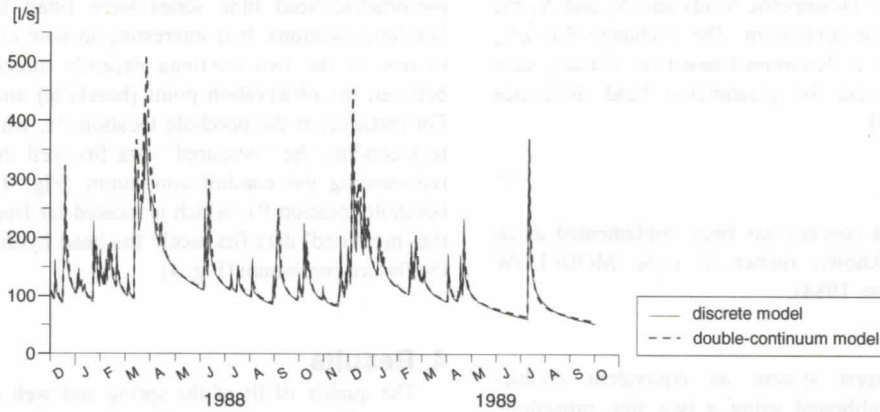

piezometric heads P1

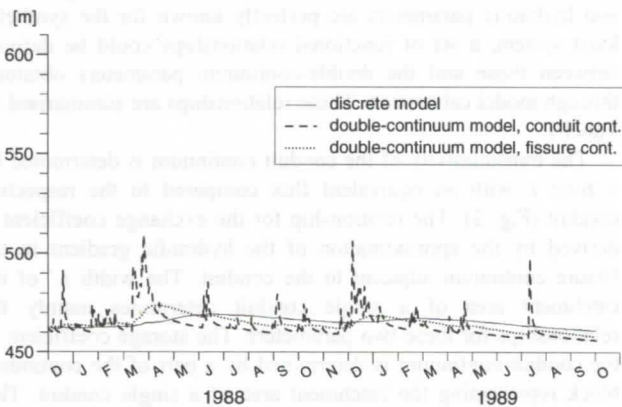

piezometric heads P4

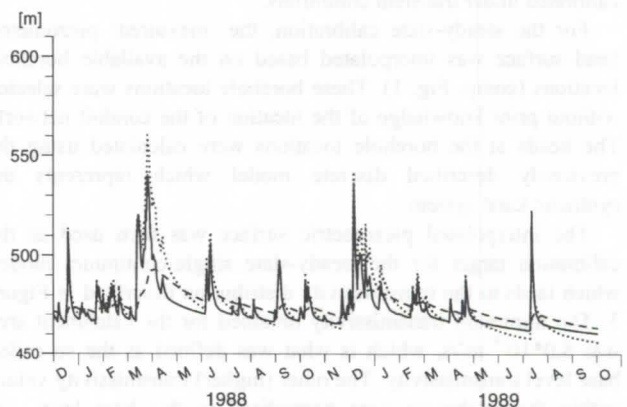

Figure 4: Spring discharge and piezometric head time series at the measurement points P1, P4 of the calibrated double-continuum model.

hydraulic parameters	geometric und physical relationships of the parameters	zones determined by calibration
exchange coefficient	approximation of hydr. gradient: $\alpha = \frac{1}{f} \frac{T_k}{L^2}$, $f = 0.2 \dots 0.5$	catchment area of conduits: $L' = 26 \dots 450$ m
transmissivity of conduit cont.	flux equivalent to conduit: $T_1 = \sqrt{\frac{\pi^2 g}{8 \lambda \nabla h}} \frac{d^{5/2}}{L}$	$L = 45 \dots 500$ m
storage coefficient of conduit cont.	similar hydraulic behavior as conduit: $S_1 = S_k \frac{L'}{L^*}$	$L^* = 15$ m
transmissivity of fissure cont.	identical cont. approach: $T_2 = T_k$	—
storage coefficient of fissure cont.	subdivision of whole storage volumen: $S_2 = S_k - S_1$	—

Table 1: Relationships between the hydraulic parameters of the double-continuum model and the geometric and hydraulic parameters of the discrete model.

Seichten Malmkarst der Schwäbischen Alb. PhD-thesis at the Geologic-Palaeontologic Institute, University of Tübingen, 220 p.

TEUTSCH, G. & M. SAUTER 1991. Groundwater modelling in karst terranes: scale effects, data acquisition and field validation. Proc. Third Conference on Hydrogeology, Ecology, Monitoring and Management of Ground Water in Karst Terranes, Dec. 1991, Nashville.

WOLLRATH, J. & R. HELMIG 1991. SM-2, Strömungsmodell für inkompressible Fluide. Theory and user manual, Institute for Fluidmechanics, University of Hannover, technical report.

Acknowledgments

The presented study has been supported by the German Science Foundation (DFG).

Modelling groundwater flow in a karst terrane using discrete and double-continuum approaches

- importance of spatial and temporal distribution of recharge -

U. Mohrlök*, M. Sauter

Applied Geology, Geological Institute, University of Tübingen, Germany

Abstract

Groundwater flow had been modelled in the karst catchment area 'Gallusquelle' (Swabian Alb, SW-Germany) using two different types of modelling approaches. The discrete and the double-continuum model differ in their respective representation of the conduit network and the formulation of the exchange flux of groundwater between fissured system and conduits. In the case of the discrete approach this exchange is determined by local hydraulic properties adjacent to the conduits. The double-continuum approach represents this exchange using a 'steady state', lumped parameter. As a result of this fundamental difference between the two approaches, the temporal distribution as well as the percentual allocation of groundwater recharge to conduits and fissured system plays a major role in the respective model calibration.

Kurzfassung

Die Grundwasserströmung im Karsteinzugsgebiet der 'Gallusquelle' (Schwäbische Alb, SW-Deutschland) wurde mit zwei Modellansätzen beschrieben. Diskretes und Doppel-Kontinuum-Modell unterscheiden sich in ihrer jeweiligen Beschreibung des Karströhrennetzes und der Formulierung des Austausches von Grundwasser zwischen Feinkluftsystem und Karströhrennetz. Beim diskreten Ansatz wird dieser Austausch durch die hydraulischen Eigenschaften in der Umgebung der Karströhren bestimmt. Der Doppel-Kontinuum-Ansatz repräsentiert diesen Austausch mit Hilfe eines 'stationären' Parameters. Als Ergebnis dieses fundamentalen Unterschieds zwischen beiden Ansätzen spielt die zeitliche Verteilung sowie die Aufteilung der Grundwasserneubildung auf die Karströhren bzw. das Feinkluftsystem eine wesentliche Rolle bei der jeweiligen Modellkalibrierung.

1. Introduction

The hydraulic properties of most karst aquifers can be characterised by typical discharge and piezometric head time series. The observed features of these time series are a steep initial increase and decrease after recharge events and a more or less long recession period. Further, groundwater level fluctuations increase with increasing distance from the spring. These observations can be explained by the hierarchical structure of void volume in a karst aquifer. A network of highly permeable karst conduits has developed as a result of carbonate dissolution in the original fissured carbonates. These conduits drains the permeable, high storage fissured system. Different model approaches describing groundwater flow in such dual permeability systems are summarized by TEUTSCH & SAUTER (1991).

In the presented study the discrete and the double-continuum approach were compared describing groundwater flow in the 'Gallusquelle' karst catchment area (Fig. 1). They differ in their representation of the conduit network. Therefore, the mathematical formulation of the exchange flux of groundwater between the fissured system and the conduit network has to be different for the two approaches.

Generally it is assumed, that a zone exists near the surface, the epikarst (WILLIAMS, 1983), acting as a buffer for groundwater recharge. This horizon effects strongly the temporal and spatial distribution of groundwater recharge. A fraction of the infiltrated water flows rapidly towards doline structures and is conveyed to the conduit system of the aquifer via vertical shafts. The rest slowly drains to the phreatic zone.

Depending on the type of the selected groundwater flow model different temporal distribution as well as different percentual allocation to conduits and fissured system for the

recharge input function have to be chosen. In this paper it is discussed whether this phenomenon can be used to derive the recharge mechanism in a karst terrane or if it is related to the respective model approach.

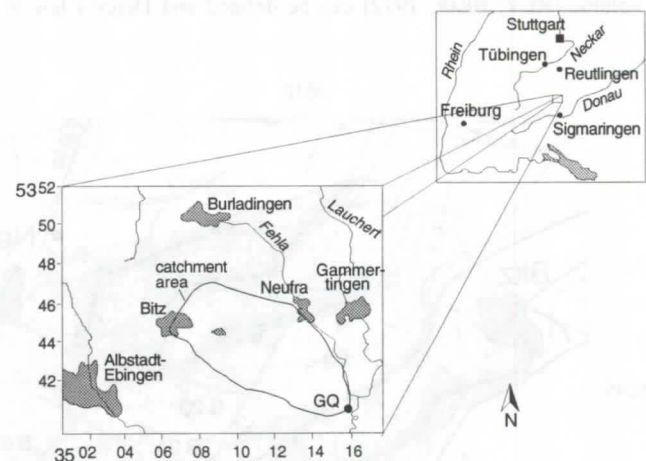

Figure 1: Location of the 'Gallusquelle' catchment area

2. The 'Gallusquelle' catchment area

Geology, hydrogeology

The Swabian Alb consists of a sequence of Upper Jurassic limestones, which vary between bedded and massive, bioherm facies. The catchment area of the 'Gallusquelle' is situated in the

* Institute for Hydromechanics, University of Karlsruhe, Germany

massive facies of the Upper Jurassic (ki2/3). At the surface typical karst features such as dry valleys and doline structures are visible. In the past, a number of geological and hydrogeological investigations had been performed, especially in context with a large water supply project during the sixties. Information about the catchment boundaries is summarized by SAUTER (1995). Additionally, aerial photographs and satellite images were analysed in order to identify lineaments as zones of major karstification and potential conduits (BRUX, 1981).

Recharge

It is assumed, that the epikarstic horizon plays a major role in the temporal and spatial distribution of groundwater recharge (SAUTER, 1994). Water enters the subsurface and collects in a highly porous and highly conductive horizon. There, a perched water table is formed and a certain percentage of the recharge water flows towards vertical shafts and is rapidly conveyed to the groundwater table. This way, the epikarst system can function on the one hand as a high storage buffer and on the other hand as a highly transmissive system for rapid infiltration.

The recharge is calculated using a soil moisture balance approach. Potential evapotranspiration was computed after HAUDE (1955) based on recorded meteorological data. The delaying effect of snow melt and epikarst is accounted for separately. A certain quantity of recharge is allocated directly to the conduit network. The rest infiltrates into the fissured system.

3. Groundwater flow modelling

Discrete approach

The conduit network is represented by a geometric discrete pattern. Flow in the conduits is calculated using the friction law of Darcy-Weisbach. The fissured system is represented by a continuum. Since at the regional scale of the catchment area the number of fissures is large enough, a representative elementary volume (REV; BEAR, 1972) can be defined and Darcy's law is

used to describe groundwater flow in the continuum. The exchange flux q_{ex} between the conduits and that continuum is defined by:

$$q_{ex} = -K_f \frac{A_{ex}}{V_{tot}} \nabla h_f \Big|_{\mathbf{x}_f = \mathbf{x}_c} \quad (1)$$

K_f is the hydraulic conductivity of the fissured system, A_{ex} the interface between the conduit and the fissured system, V_{tot} the bulk volume of the adjacent continuum block and ∇h_f the hydraulic gradient in the fissured system at the interface ($\mathbf{x}_f = \mathbf{x}_c$). This approach is implemented in the finite element code ROCKFLOW (WOLLRATH *et al.*, 1991).

Using this approach a two-dimensional model was built for the 'Gallusquelle' catchment area. The conduit network was derived from available informations (Fig. 2). For discrete modelling, no intermediate storage within the epikarst was assumed and 95% of the recharge was allocated directly to the conduit network (Fig. 3).

Double-continuum approach

This approach represents both subsystems, the fissured system as well as the conduit network, by a continuum, where groundwater flow is described by Darcy's law. This is the simplest way to overcome the lack of knowledge of the exact geometry and positions of the conduits and still to represent a fast flow system. The two continua overlap in space. The exchange flux q^*_{ex} between them is defined by a 'steady state' exchange coefficient α_0 and the piezometric head difference between the two subsystems (BARENBLATT *et al.*, 1960):

$$q^*_{ex} = \alpha_0 (h_1 - h_2). \quad (2)$$

This approach is implemented in a further development of the numerical code MODFLOW (MCDONALD & HARBAUGH, 1984) and was successfully applied to several karst areas on the Swabian Alb (TEUTSCH, 1988; SAUTER, 1992).

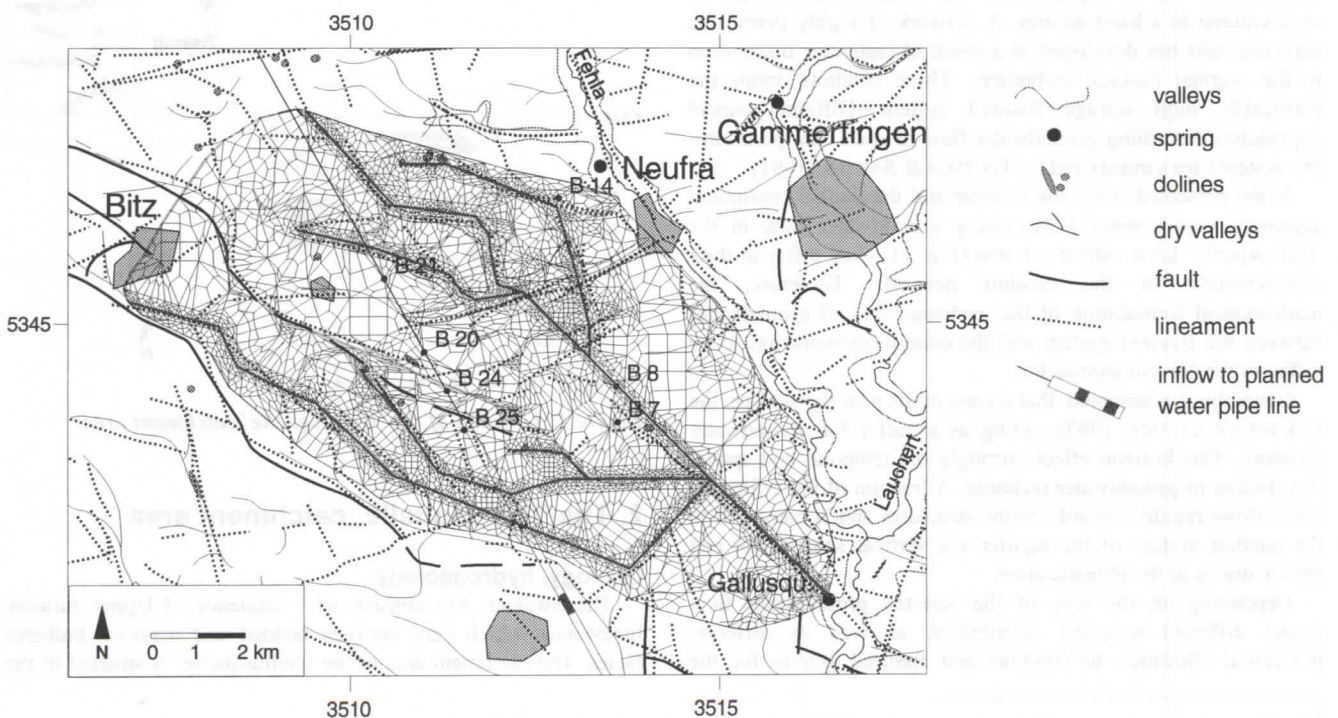

Figure 2: Conduit network derived from available information, and discretisation of the discrete model

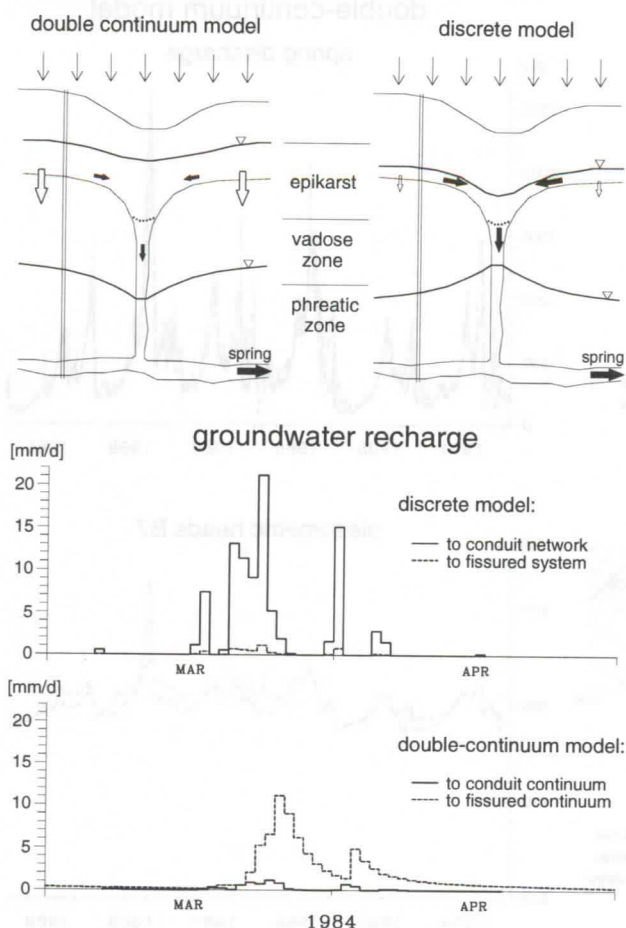

Figure 3: Recharge allocation to the two subsystems and temporal distribution of a single recharge event for both models

SAUTER (1992) used a one-dimensional model to simulate groundwater flow and transport in the 'Gallusquelle' catchment area (Fig. 4). In order to account for the buffering role of the epikarst, he developed a retention function and allocated only 7% of the calculated recharge to the continuum representing the conduit network (Fig. 3).

Results

Both models are able to fit the time series of the spring discharge well (Fig. 5). In the discrete model the distances between the piezometric head measurement points and the conduits are not represented adequately, since the location of the single conduits were not varied during the calibration process. On the other hand, in the neighbourhood of the original measurement point nodes exist, where the calculated piezometric head time series shows similar characteristics as the measured one (Fig. 5). In the double-continuum model the measured piezometric head is assumed to be that of the fissured continuum because the probability that the borehole taps a conduit is very low (Fig 5).

4. Discussion

Comparing the different models, it is obvious that both were able to reproduce the observed discharge and piezometric heads even if different recharge input functions were used. These input functions were not chosen arbitrarily. Their distinct choice in combination with the determination of the model parameters was necessary to calibrate the respective model successfully.

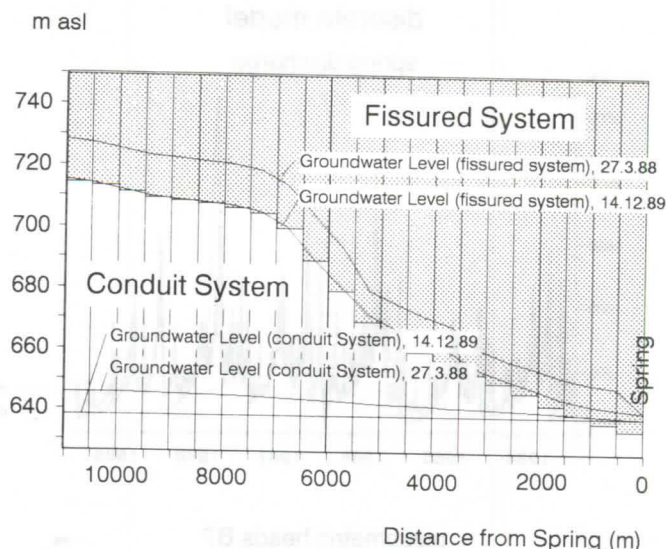

Figure 4: Discretisation of the double-continuum model

Both models show that there is a large quantity of recharged groundwater that had to be stored within an intermediate time scale. At the same time a certain amount of water has to discharge rapidly and the remaining water has to be stored for a long time producing a low recession.

In the discrete model most of the water is allocated to the conduit network. It flows into the fissured continuum as a result of the steep hydraulic gradient between the discrete conduits and the fissured system. When the pressure in the conduits decreases this water flows back from the fissured continuum resulting as low recession. In this way, characteristic piezometric head time series can be modelled in the fissured system for certain distances to the conduits.

In the double-continuum model this process does not occur, since the two subsystems are coupled directly at every node. Therefore, the equivalent storage process had to be assumed to occur in the epikarst.

Both interpretations, storage in the karst aquifer for the discrete approach and in the epikarst for the double-continuum approach, are in agreement with the respective conceptual models of the recharge process and the hydraulic properties of a karst aquifer. However, it should not be caused by the groundwater flow model assumptions which kind of model for the recharge process has to be used. Further research is needed to answer the question where the recharged water is really stored. Then a realistic model approach can be applied and the nature of the exchange processes can be identified.

References

- BARENBLATT, G. E., ZHELTOV, I. P. & I. N. KOCHINA. 1960. Basic concepts in the theory of the seepage of homogeneous liquids in fissured rocks. *J. Appl. Math. Mech. (USSR)*: 1286-1303.
- BEAR, J. 1972. Dynamics of fluids in porous media. Elsevier, New York, 764 p.
- BRUX, C. 1981. Vergleichende Untersuchungen der Bruchtektonik im Bereich des Hohenzollern- und Lauchertgrabens (Schwäbische Alb) im Luftbild, Satellitenbild und Gelände. Unpublished diploma thesis. University of Karlsruhe, 66 p.

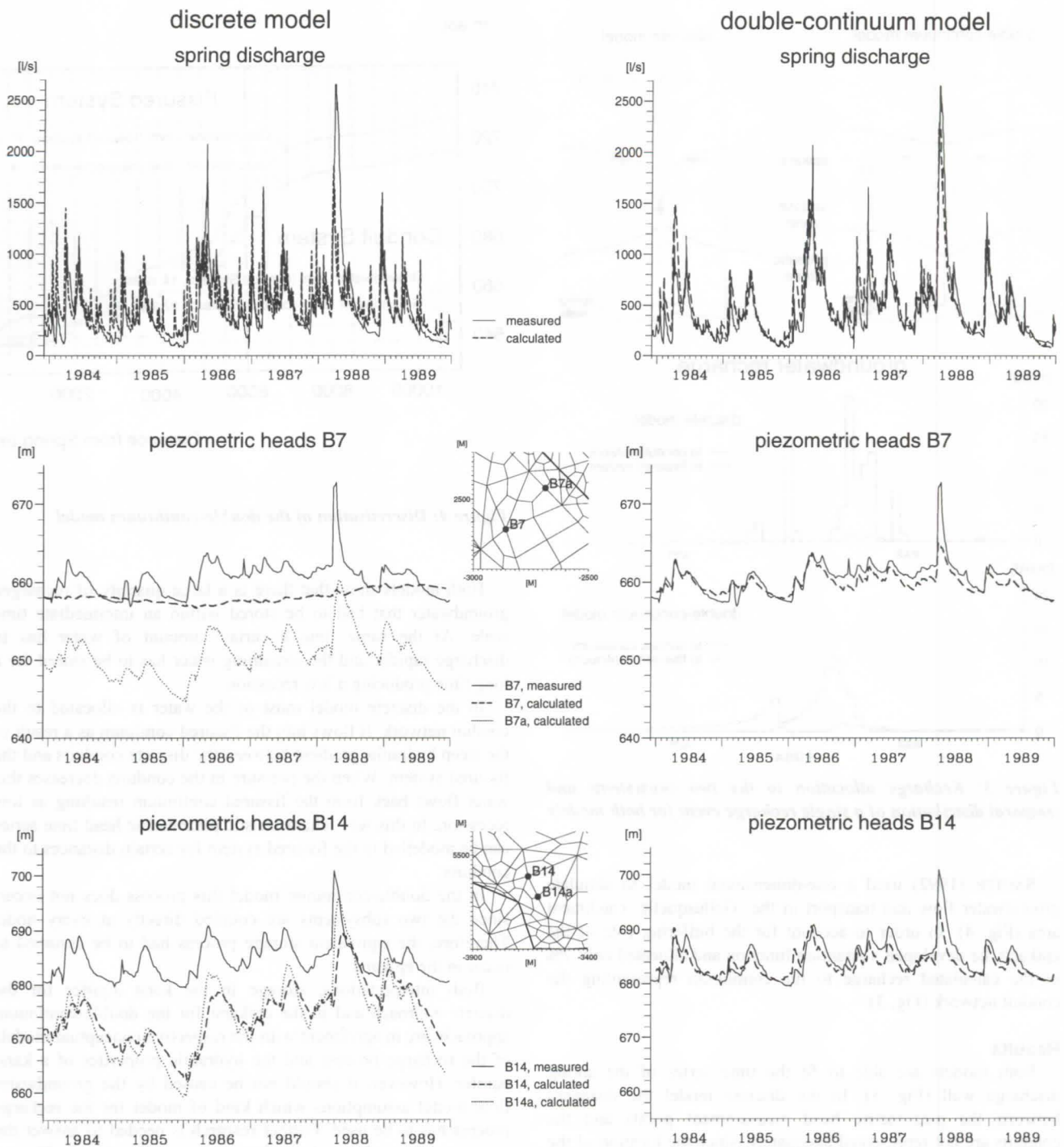

Figure 5: Spring discharge and piezometric heads of the two calibrated models

HAUDE, W. 1955. Zur Bestimmung der Verdunstung auf möglichst einfache Weise. *Mitt. Dt. Wetterdienst* 11: 1-24.

MCDONALD, M. G. & A. W. HARBAUGH 1984. A modular three-dimensional finite-difference groundwater flow model. USGS, Reston, 527 p.

SAUTER, M. 1992. Quantification and forecasting of regional groundwater flow and transport in a karst aquifer (Gallusquelle, Malm, SW. Germany). PhD-thesis, *Tübinger geowissenschaftliche Arbeiten* C13, 150 p.

SAUTER, M. 1994. Areal-source transport in a karst system. Proc. Water Down Under '94, Nov. 1994, Adelaide, Australia.

SAUTER, M. 1995. Delineation of a karst aquifer using geological and hydrological data and information on landscape development. *Carbonates and Evaporites*, 10/2: 129-139.

TEUTSCH, G. 1988. Grundwassermodelle im Karst: Praktische Ansätze am Beispiel zweier Einzugsgebiete im Tiefen und Seichten Malmkarst der Schwäbischen Alb. PhD-thesis at the Geologic-Palaeontologic Institute, University of Tübingen, 220 p.

TEUTSCH, G. & M. SAUTER 1991. Groundwater modelling in karst terranes: scale effects, data acquisition and field validation. Proc. Third Conference on Hydrogeology, Ecology, Monitoring and Management of Ground Water in Karst Terranes, Dec. 1991, Nashville.

WILLIAMS, P.W. 1983. The role of the subcutaneous zone in karst hydrology. *J. of Hyd.*, 61: 45-67.

WOLLRATH, J. & R. HELMIG 1991. SM-2, Strömungsmodell für inkompressible Fluide. Theory and user manual, Institute for Fluidmechanics, University of Hannover, technical report.

Water levels as response functions for different porous-fissured-karstic systems.

by Jacek Motyka(1) and Andrzej Zuber(2),

(1) University of Mining and Metallurgy, PL-30065 Cracow, Mickiewicza 30, Poland,

(2) Institute of Nuclear Physics, PL-31342 Cracow, Radzikowskiego 152, Poland

Abstract

In carbonate rocks the following three basic types of porosity exist: matrix porosity, fissure porosity and cavern (karstic) porosity. Existence of these three porosities in different proportions and characterized by different hydraulic conductivities influences the dynamic behaviour of the water system. That behaviour can be observed by changes in water level as a function of time. Different case studies will be presented.

1. Introduction

In general, for carbonate rocks, three systems can be distinguished, which clearly differ geometrically and have different hydraulic characteristics: the cavernous (karstic), fissured, and porous spaces. Forms filled by secondary material can be included into these systems, because they are very often unstable and can change their geometry and hydraulic parameters when the hydraulic gradient changes. Neither an exact definition nor an exact determination of particular spaces is possible, because they do not differ in origin and overlap one another.

According to Choquette and Pray (1970), the porous space is represented by empty spaces of any origin, which are observable in a small rock sample, say, of the order of several tens of cm^3 . Fissures can also be of different origin, but they are characterized by space orientation and two dimensions (length and width) which are much larger than the third dimension (aperture). Caverns are arbitrarily defined as empty forms with the cross-section area on an exposed surface, which is not smaller than 0.001 m^2 , or with length in a borehole not shorter than 0.1 m (Motyka and Szuwarzynski, 1994). The presence of these three different spaces in carbonate rocks influences the dynamics of water and solute transport. Within this work, fluctuations of the water table are discussed as a response to the importance of particular spaces in different aquifers of triple porosity. The discussion is based on case studies from Cracow-Olkusz area, southern Poland.

2. Water table in the area of a well developed paleokarst (Olkusz region)

In the period of 1962-65 the water table level was measured in about 60 boreholes and several observation wells (piezometers) in dolomites and limestones of the Lower and Middle Triassic. The water table appeared to be very irregular (Fig. 1A). In the central part, it was possible to observe an elongated and narrow drainage zone with an axis having the E-W direction. The recharge of the area is from the eastern and south-eastern directions. The carbonate formations have the average thickness of about 100 m and lie at the depth of about 30 to about 200 m below the ground level. On a large area they are covered by Keuper clays overlain by Jurassic limestones (Fig. 1B).

During drillings about 50 caverns were discovered with the length along the borehole axis of about 0.3 to 4.5 m . Some of them were filled with breccias regarded as being of karstic origin. The roof surface of the carbonates is hilly with a distinct depression directed from EES to WWN, and 1.5 to 2.0 km wide.

That depression has a relatively flat bottom with a number of local elliptical funnel depressions up to 30 m deep. According to Wilk et al. (1989) it is a paleorelief characteristic for advanced karstification processes. As a result of that, the main role in the development of the shape of natural water table with numerous irregularities (before the exploitation of mines has started) was played by the internal drainage system of the karstic caverns and channels within the Triassic formations.

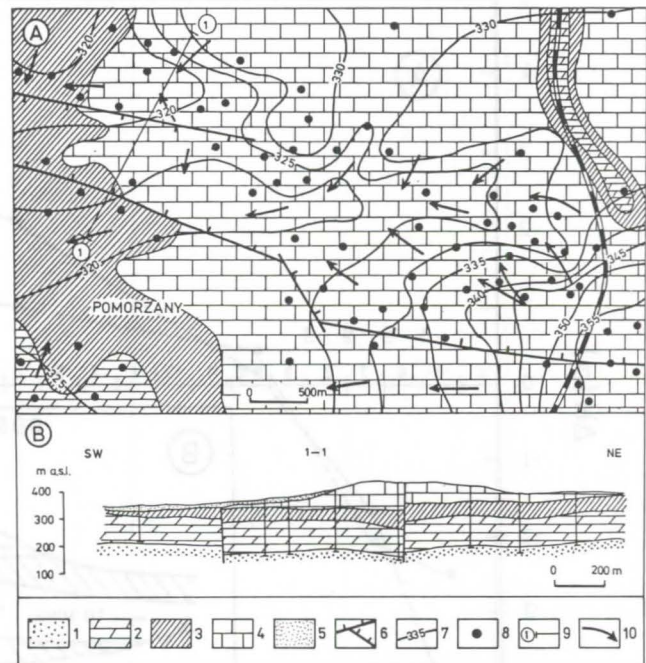

Fig.1. Hydrogeology of the eastern part of the Olkusz region
A. Water table in the Triassic aquifer. B. Geological cross-section. 1-Permian, 2-Triassic aquifer, 3-Keuper, 4-Jurassic, 5-Quaternary, 6-faults, 7-water table contours, 8-observation wells, 9-cross-section line, 10-directions of groundwater flow.

3. Water table fluctuations in a zone of different hydraulic connections between carbonate rocks (Olkusz region)

That example is also related to the Olkusz mining area of Zn-Pb ores, where as the result of drainage by mines and an intensive exploitation of water, a large depression cone has formed, mainly in the Triassic limestones and dolomites. By different forms of hydraulic connections that cone locally

influences the Carboniferous-Devonian, Jurassic and Quaternary aquifers (Wilk and Motyka, 1977).

In the south-eastern part of the region, the Carboniferous-Devonian formations are elevated in the eastern direction and gradually are covered by Triassic and next by Jurassic (Malm) aquifers. That part of the region is therefore characterized by complex hydraulic connections between rocks of different ages and hydraulic parameters (hydraulic conductivity and storage characteristics in different kinds of spaces).

The Jurassic limestones are fractured and with well developed karstic forms. In spite of a high matrix porosity (0.07-0.10), its hydraulic properties practically do not influence the hydraulic properties of the aquifer. Therefore, the aquifer is mainly of the double porosity type, i.e., a karstic-fissured system. The Triassic limestones and dolomites are characterized by well developed systems of caverns and fissures as well by relatively high hydraulic conductivity and specific yield of the porous space. Therefore, they are classified as a triple porosity type, i.e., a karstic-fissured-porous system (Motyka, 1988). The Carboniferous and Devonian limestones and dolomites are practically permeable only due to the presence of fractures (though caverns are sporadically observed) because the porous space is of negligibly low hydraulic conductivity and specific yield (Borczak et al., 1994). Therefore, that aquifer is of the single porosity type, i.e., a fractured system (a quick response in

which are recharged indirectly from the Jurassic aquifer. All these make the whole zone to be quite complex (Fig. 2).

In that complex zone three piezometers have been installed at close distances at Jurassic, Triassic, and Devonian aquifers. Unfortunately, the natural behaviour remains unknown because the water levels measurements were started when the Triassic aquifer was already strongly drained by mines. The results of observations in Triassic and Devonian aquifers are shown in Fig. 2A as differences in the respect to the water level in the Jurassic aquifer. These results can be explained both by considering the geological structure of the zone and by taking into account the differences in the hydraulic properties of the three carbonate systems. Namely, the Devonian limestones and dolomites being a fissured systems are characterized by relatively good hydraulic conductivity and low storativity (specific yield), and, therefore, they quickly respond to changes in the water table in the Jurassic aquifer. The Triassic limestones and dolomites due to an important role of the porous space in the storage of water respond much slower and to a lower degree. The overlapping effects of the drainage in the Triassic aquifer, inflow from the Jurassic aquifer to the lower ones, and the differences in the hydraulic properties lead to the behaviour of the water table responses which at the first glance may seem to be inconsistent (Fig. 2A), though it may be explained by differences in characteristics of particular porous spaces.

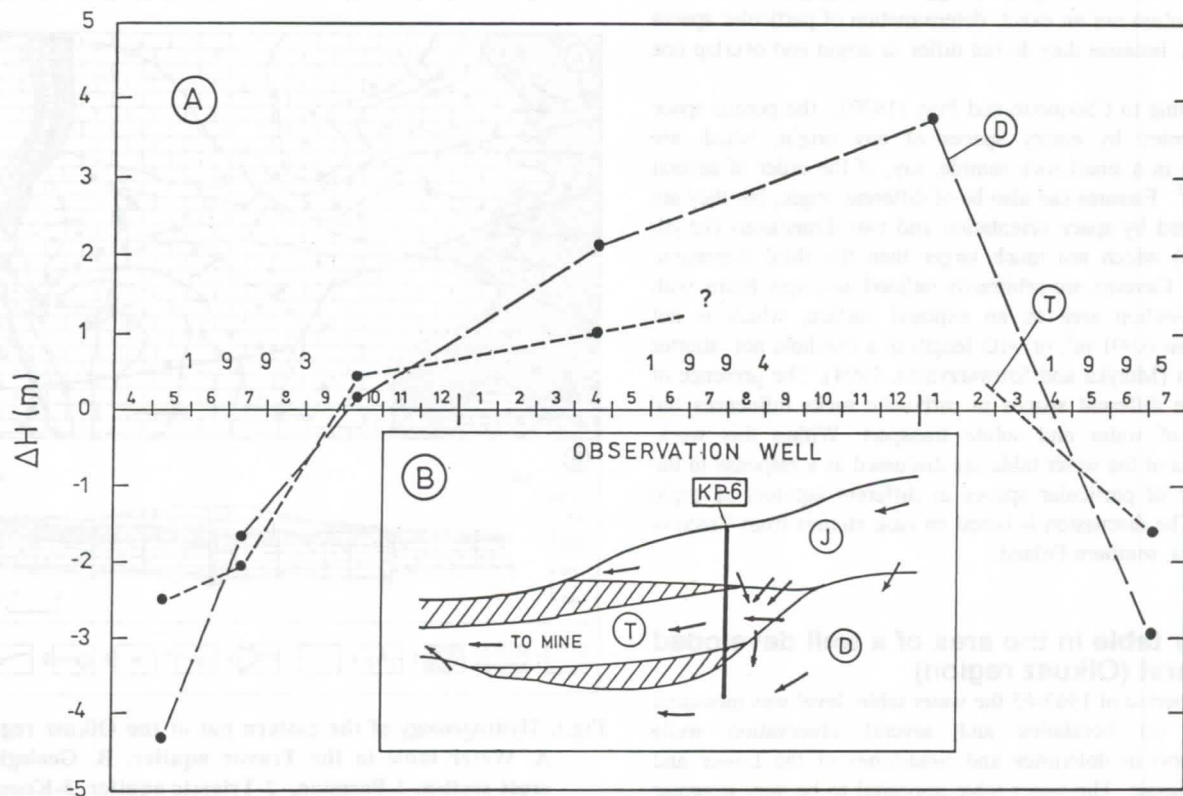

Fig. 2. A. Differences in water table levels (ΔH) in the Triassic aquifer (T) and the Carboniferous-Devonian aquifer (D) in respect to the water table in the Jurassic aquifer. B. Schematic cross-section and directions of groundwater flow.

water table changes, i.e., a very low inertia of the system). The above given classification is related only to the flow dynamics. For transport parameters the matrix porosity plays a dominant role (Zuber, Motyka, 1994; Motyka et al., 1994).

As a result of a significant decline of the water table in the Triassic system (about 80 to 100 m at the centre of the drainage area), that system is recharged in the south-eastern part by vertical flows from the Jurassic limestones at the local hydraulic connections. A significant role is also played by local horizontal flows from the Carboniferous and Devonian carbonate aquifers

4. Recovery of the water table in an abandoned quarry

Malm limestones were exploited from a Zakrzówek quarry in Cracow, which is situated about 600-900 m from the Vistula river whose flow is usually between 50 and 200 m³/s. Exploitation was performed to the depth of about 60 m below the ground surface, i.e., in the deepest parts of about 30 m below the river level (Fig. 3). In November 1992 the exploitation of limestone was stopped and the quarry has started to be filled in

by inflowing groundwater. The recovery of the water table as a function of time is shown in Fig. 4).

At the beginning the increase of water table level was 2-3 cm/d, and next for more than 700 days it was on the average equal to about 1.9 cm/d. The final stages are characterized by changes of about 1 cm/d. Temporary faster changes were related to snow melt and intensive precipitation events. These events are particularly well seen at the middle and final stages of the recovery curve (Fig. 4).

hydraulic network (Fig. 3). The interbedding planes slightly dip at the angle of several degrees from the Vistula river to the quarry. Outflows from caverns existed only temporarily.

The main feature of the recovery curve (Fig. 4) is the existence of two straight parts, if temporal changes caused by intensive rains are neglected. The hydraulic conductivity is governed by the fissure system, which explains the first straight part of the line. When a sufficiently high water pressure was created in the fissure network, the porous and microfissure

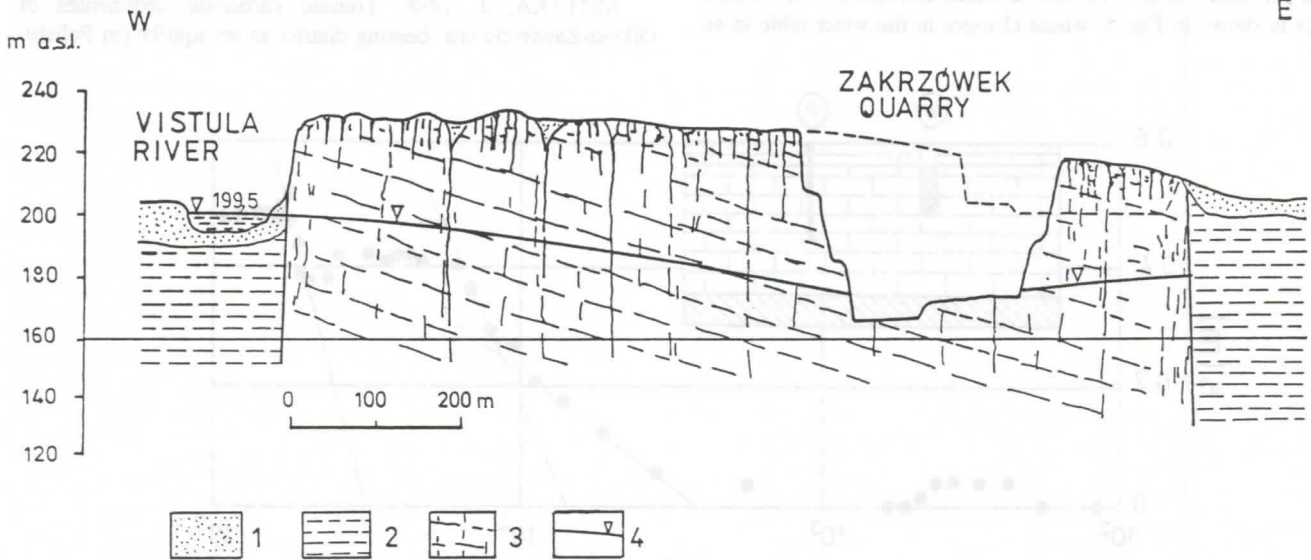

Fig.3. Geological cross-section through the Zakrzówek horst. 1- Quaternary, 2-Miocene clays, 3-Jurassic limestones, 4-water level during the exploitation.

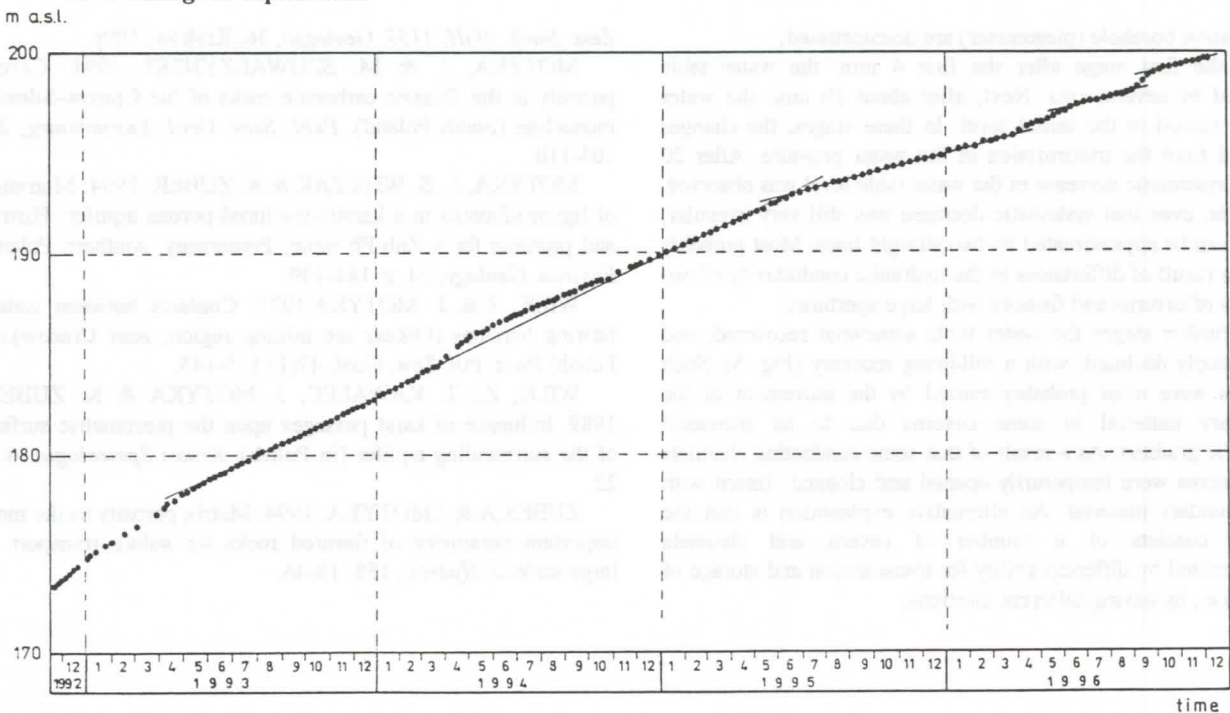

Fig. 4. Water table recovery curve the Zakrzówek quarry.

There are three porous spaces in the Malm limestones of that region: cavernous, fissured and porous. The mean matrix porosity is 0.076 as determined on 418 samples whereas the cavernous and fissured porosities together are estimated visually to be below 0.01. The hydraulic conductivity is mainly governed by fissures and interbedding planes which form an orthogonal

systems most probably started to be filled in, and, in consequence, the second part of a slower recovery was observed.

5. An example of changes in water table caused by pumping test

Heterogeneities of karstic-fissured systems can also be observed during pumping tests. In the case of the presence of karstic forms partly filled in with secondary material the depression curve does not correspond to the shape expected from the Theis or Theis-Jacob methods. Very often the water level declines and partly recovers. Till now no reliable methods exist for the interpretation of such results. An example of a pumping test performed in the Triassic carbonate formation of the Olkusz area is shown in Fig. 5, where changes in the water table in an

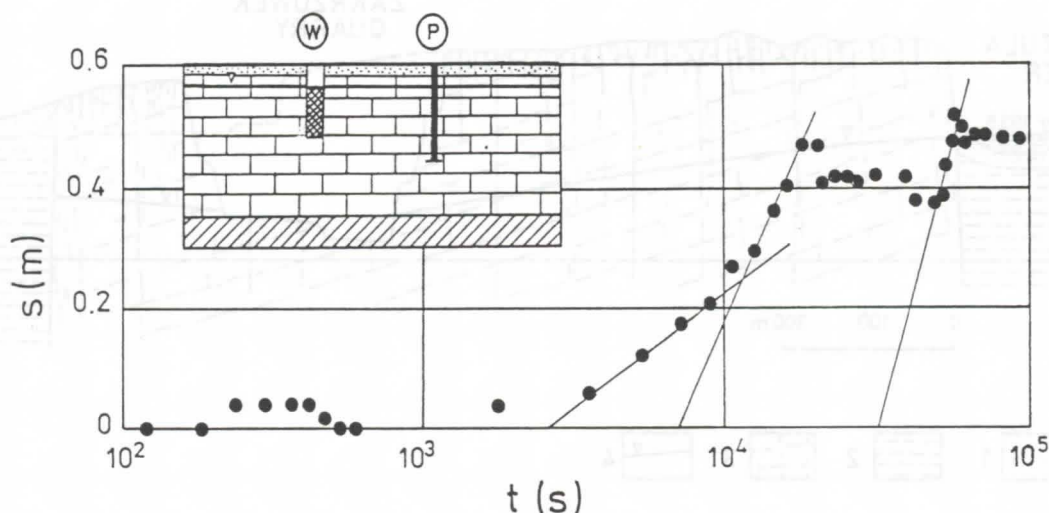

Fig. 5. An example of irregular changes in the depression curve in an observation well (P) during a pumping test (well W).

observation borehole (piezometer) are demonstrated.

In the first stage after the first 4 min. the water table declined by several cms. Next, after about 10 min. the water table returned to the initial level. In these stages, the changes resulted from the transmission of the water pressure. After 20 min. a systematic decrease of the water table level was observed. However, even that systematic decrease was still very irregular, and it can be approximated by two straight lines. Most probably it was a result of differences in the hydraulic conductivity of two systems of caverns and fissures with large apertures.

In further stages the water table somewhat recovered, and next steeply declined, with a following recovery (Fig. 5). Such changes were most probably caused by the movement of the secondary material in some caverns due to an increased hydraulic gradient. As a result of that some conducting channels and fissures were temporarily opened and clogged intern with the secondary material. An alternative explanation is that the system consists of a number of cavern and channels characterized by different ability for transmission and storage of water, i.e., by having different inertions.

References

- BORCZAK, S., T. LESNIAK, & J. MOTYKA, 1994. Hydrogeological properties of the pore space of the Lower Carboniferous Czatkowice limestones and dolomites (SW Poland) (in Polish). *Przegl. Geol.* 8: 653-657.
- CHOQUETTE, P.W. & L.C. PRAY, 1970. Geologic nomenclature and classification of porosity in sedimentary carbonates. *The Am. Assoc. of Petrol. Geol. Bull.* 54, 2: 207-250.
- MOTYKA, J. 1988. Triassic carbonate sediments of Olkusz-Zawiercie ore-bearing district as an aquifer (in Polish).

Zesz. Nauk. AGH, 1157, Geologia, 36, Kraków, 109p.

MOTYKA, J. & M. SZUWARZYNSKI. 1994. Cavern porosity in the Triassic carbonate rocks of the Cracow-Silesian monocline (South Poland). *Publ. Serv. Geol. Luxembourg, 27: 103-110.*

MOTYKA, J., S. WITCZAK & A. ZUBER. 1994. Migration of lignosulfonates in a karstic-fractured-porous aquifer: History and prognosis for a Zn-Pb mine, Pomorzany, southern Poland. *Environ. Geology, 24, z. 144-149.*

WILK, Z. & J. MOTYKA. 1977. Contacts between water-bearing horizons (Olkusz ore mining region, near Cracow). (in Polish) *Rocz. Pol. Tow. Geol.* 47(1):115-143.

WILK, Z., T. KAWALEC, J. MOTYKA & K. ZUBER. 1989. Influence of karst passages upon the piezometric surface of the surrounding aquifer (in Polish). *Kras i Speleologia. 6:7-22.*

ZUBER, A. & J. MOTYKA. 1994. Matrix porosity as the most important parameter of fissured rocks for solute transport at large scale. *J. Hydrol., 158: 19-46.*

Application of flow models to the prediction of karst behaviour and pollutant migration in a groundwater system

Maria Pascu, R.D.Gaspar

Institute of Physics and Nuclear Engineering , Bucharest , Romania

Abstract

The most important karstic system from Valcan Mountains discharges through the Izvarna springs, 2.2 m³/sec which are tapped and piped for water supply to the city of Craiova.

The connections between the springs and the main inflows were identified with activable tracers. The karst behaviour and the vulnerability to pollution were investigated by using In-EDTA as a tracer. Hydraulic dispersion of the pollutants involves the transfer of a dissolved constituent from a higher concentration zone to a lower concentration zone by means of mixing and molecular diffusion. Dispersion has a very significant influence on the migration of solutes in large groundwater systems.

Using the dispersion model, the flow parameters as such velocity, length of the underground flow path, transit time and hydrodynamic dispersion coefficient were determined.

Résumé

Le jeu de sources d'eau d'Izvarna, ayant un débit de 2.2 m³/sec est le système karstique le plus important de ceux appartenant aux Montagnes Valcan. Il est utilisé pour approvisionner la ville Craiova.

On a utilisé des traceurs activables pour mettre en évidence des rapports entre les deux groupes de sources captées et les trois points de pertes observés. Le comportement du karst et sa vulnérabilité aux polluants ont été examinés en utilisant comme traceur le In-EDTA. Comme règle générale, la dispersion hydraulique implique le transfert de la substance dissoute d'une zone de grande concentration vers une autre zone, de concentration plus basse, par les moyens du mélange et de la diffusion moléculaire.

Dans des grands systèmes d'eaux souterraines, la dispersion peut jouer un rôle très important dans la migration des solutés. En soutenant cette affirmation, nos dates expérimentales pour les trois sub-systèmes de sources sont présentées dans le texte qui suit.

1. Introduction

One of the most complex hydrogeological structures and karst interconnections from Valcan Mountains, Romania, extending on more than 500 sq.km includes three karstic systems: Izvarna, Jales and Patrunsa-Picuiel. The Izvarna karst springs, with a flow roughly 2.2 cum./sec and variation coefficient of 1.4. 2.0 are major sources of potable water supply for Craiova town.

In the 15 last years, a large deforestation and urbanization caused a increasing pollution and a degradation of water resources. As a consequence , a continuous lowering of the discharges was observed. The construction works on a major hydropower complex in the area, which implied the building of dams to create storage lakes with waters from the rivers that cross the zone, posed the problem of the influence the retentions exert on capture. Therefore , as the damming of water flows entails a diminution of the capture discharge, engineering solutions should be found to the problem.

While the demand for water is increasing and its availability being reduced and effect of growing of this pollution superposed, new hydrological studies were necessary to delineate the karst systems and to determine their vulnerability to pollution.

The connections between the springs and the main inflows were identified in the studied area with activable tracers and activation analysis.

The karst behaviour and the vulnerability to pollution were investigated by using In-EDTA as a tracer.

2. The tracer

The activable tracers have a great stability in time, reacts slowly with the labeled environment, and most of them can be considered as conservative tracers. Thus, In-EDTA has a stability constant of 24.9 and can be measured in routine determinations in concentrations down to 2.10⁻¹² g/ml. It has a very low toxicity permitting the direct labeling of the potable waters.

In-EDTA , the most used tracer by us, is considered as a reference tracer. Indium is practically absent (in the limits of the analytical method) from the investigated waters.

Samples are analysed in the laboratory. Indium is extracted from the water samples (100 ml) by precipitation. The precipitate is then filtered through a nuclear membrane filter, dried at room temperature and irradiated with a pneumatic rabbit tube at the nuclear reactor. (GASPAR & all, 1984)

The major advantage of this tracer is that, owing to its extremely low detection limit, it can label emergences of very low flow rates which cannot be labelled by other tracer, whether fluorescent, chemical or radioactive (with the exception of tritiated water) : an artificial lake or natural reservoir of 10⁶ m³ may be labelled using 100 g In a In-EDTA complex.

The detection limit can be lowered below 1.10⁻¹² g/ml using a volume of water samples larger than 100 cm³ and a larger neutron flux for irradiation (BEHRENS & all, 1977 GASPAR & al, 1985).

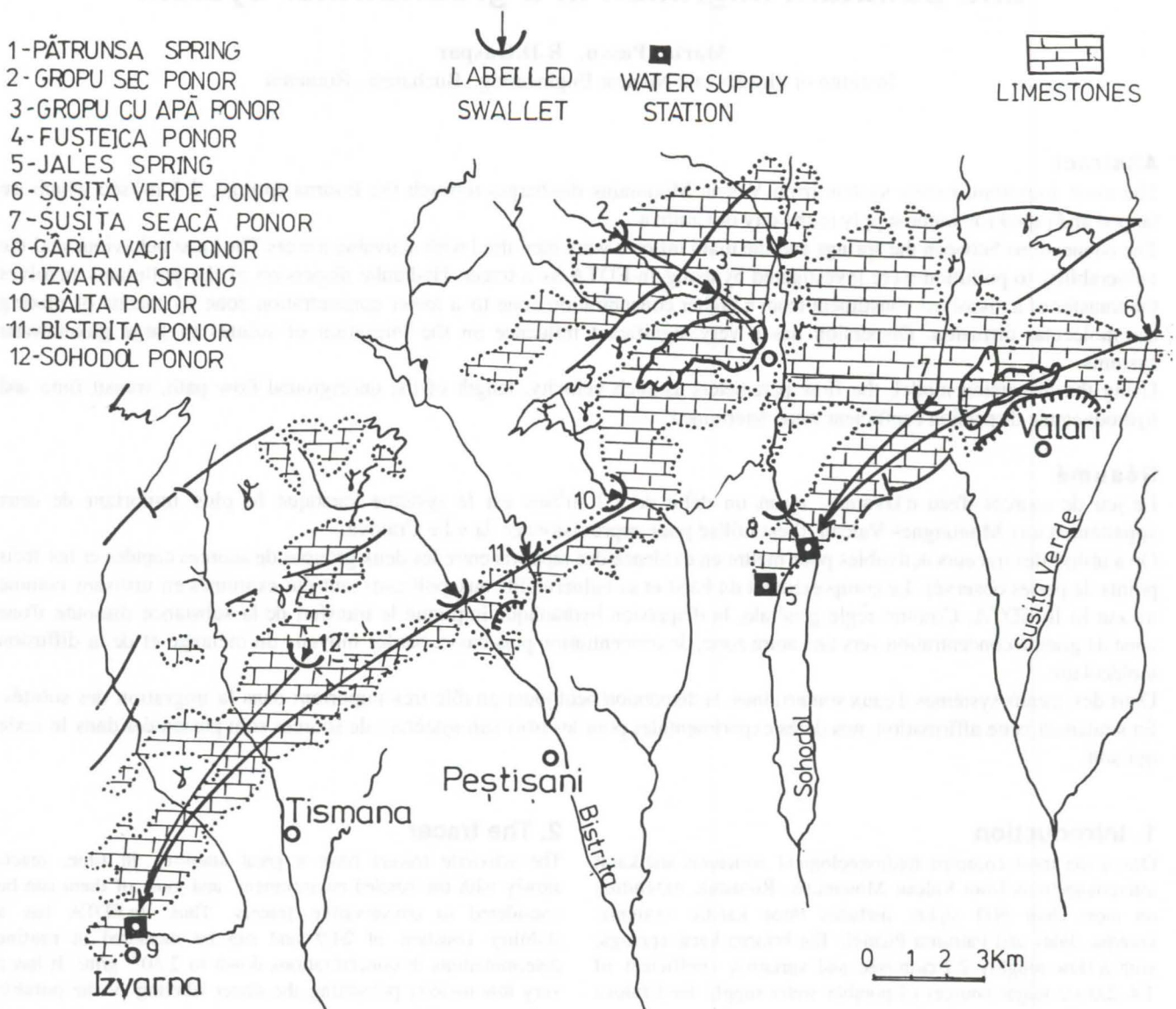

Figure.1. General sketch of Southern Valcan Mountains karst.

3. Flow models

The data obtained from tracer measurements may be used either directly or in association with flow models. Generally speaking, dispersion and mixing processes taking place during flow in a real karst hydrological system are far too complex to be entirely described mathematically; furthermore, it is difficult, if not impossible, to adapt a response function corresponding to the system under study. However, though idealized, the mathematical models and the digital simulation approach, which are currently used in hydrology (PRZEWLOCKI & YURT SEVER, 1974; YURT SEVER & PAYNE, 1978; MALOSZEWSKI & ZUBER, 1984) may lead, in certain cases, to a convincing description of the dynamic behaviour of the aquifer. These models originate in two basic approaches, the convolution approach and the quasi-physical models employing an interconnected array of mixing cells (compartmental models).

Flow in karstic structures may be modelled if the input and the output functions are known. To obtain these functions is important as they provide an assessment of the transfer function of the karstic system.

It is easy to determine the input function for tracer tests when injections have the form of a pulse. In the case of diffuse losses through river beds or lake bottoms, a deconvolution operation is needed for the assessment of the input function.

In general, experimental data (repeated labellings, multitracing experiments) supply sufficient arguments for the selection of a flow pattern with total displacement drain or branches short circuits, perfect-mixing zones (underground pools), stagnant zones (underground lakes, syphons), zones with dispersion, diffusion and exchange (auxiliary systems).

The selection of flow models and the determination of parameters from tracer studies is based on the analysis of impulse response function.

This function is the Residence Time Distribution (RTD) obtained from the system to a tracer input in the form of a Dirac delta function (sudden injection).

$$RTD \equiv E(t) = \frac{C(t)}{\int C(t)dt} \quad (1)$$

where $C(t)$ is the tracer concentration in water (i.e.mass or activity per unit.volume of water).

The impulse response functions were fitted with the dispersion function $h(t)$ as:

$$h(t) = \frac{1}{2} \frac{\bar{v}}{\sqrt{\pi Dt}} \exp - \frac{(L - \bar{v}t)^2}{4 Dt} \quad (2)$$

4.The experiment

The hydrological survey, combined with the study of the geology , of the morphology and of the hydrography of the southern slope of Valcan Mountains resulted in the delineation of three karstic systems. The artificial labellings demonstrated convergent and divergent connections between ponors and springs term.

The most important karst system flowing from north-east to the south-west discharges through the group of springs at Izvarna. (JURKIEWICZ & MANGIN,1996) .

The groundwater flow direction, the residence time distribution and the assessment of karst vulnerability to pollution were determined by tracer experiments in each system.

In this experiment, we have determined the mean transit time and the dispersion coefficients by repetitive checkings, through minimising a performance criterion.

$$\sum = \int_0^{\infty} [h(t) - E(t)]^2 dt \quad (3)$$

The results obtained in cases of the three subsystems, Valea Pargavului (figure 2) , Bistrita (figure 3) and Balta (figure 4) are presented in the table 1.

SINKHOLE	Valea Pargavului	Bistrita	Balta
Length (Km)	10.4	16.48	20.8
Mean transit time (d)	14.85	13.18	14.09
Velocity (m/d)	700	1250	1450
Dispersion coefficient (m ² /s)	0.621	5.957	5.520

Table 1. Featurers of the Izvarna karstic system

In the figures 2 , 3 and 4 are depicted the impulse response functions for the three above subsystems.

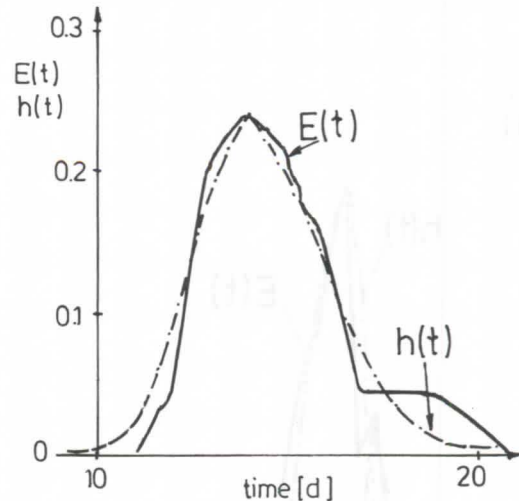

Figure 2 Transfer functions $E(t)$ and $h(t)$ for the Valea Pargavului experiment.

As it could be seen from these figures, the experimental data of the concentration of the tracers show some irregularities which are caused by either heterogeneities of the local geology or the existence of some different flowing pathways.(see fig.3).

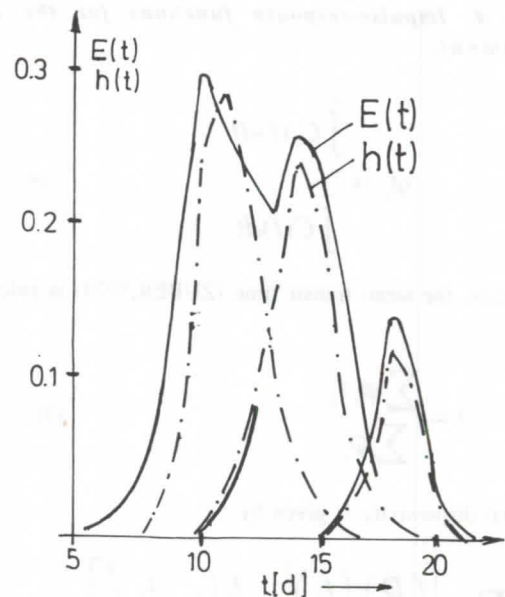

Figure 3. Time variation of tracer concentration and transfer function in the Bistrita experiment.

Even in this case, each of the experimental curve can be splitted into many partial ones, every of these partial curve being fitted to $h(t)$ (ec.2) as above, t_i , $(D/v)_i$ and ϕ_i being determined.

Here the subscript "i" stands for the number of peaks of the experimental curve and ϕ_i is the partial recovery defined as the ratio of the area under the partial curve to the area of the total concentration curve.

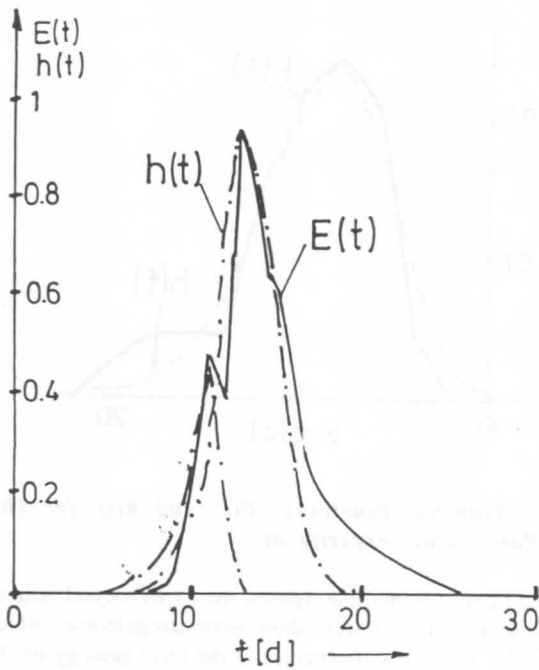

Figure 4. Impulse-response functions for the Balta experiment.

$$\varphi_i = \frac{\int_0^{\infty} C_i(t) dt}{\int_0^{\infty} C(t) dt} \quad (4)$$

In this case, the mean transit time (ZUBER,1974) is calculated as:

$$\bar{t} = \frac{\sum \varphi_i \bar{t}_i}{\sum \varphi_i} \quad (5)$$

The total dispersivity is given by :

$$\frac{D}{v} = \sum_i \varphi_i \left[\left(\frac{D}{v} \right)_i \left(\frac{\bar{t}_i}{\bar{t}} \right)^2 + \frac{L}{2} \left(1 - \frac{\bar{t}_i}{\bar{t}} \right)^2 \right] \quad (6)$$

Using this late flow model, after processing the data from the karst subsystem Bistrita-Izvarna, (see table 2) the following results could be obtained:

i	(D/v) _i [m]	\bar{t}_i [d]	φ_i
1	143	11.26	0.526
2	66	14.42	0.438
3	22	18.36	0.17
Total	407	13.54	

Table 2. Flow model parameters for the Balta experiment

D/v=407 m ; t=13.54 d ; D=5.72 m²/s and v=1214 m/d .

Using the same methodology for the Balta experiment, (see table 3), it resulted .

i	(D/v) _i [m]	\bar{t}_i [d]	φ_i
1	65	11.25	0.234
2	156	14.93	0.86

Table 3. Flow model parameters for the Balta-Izvarna experiment.

D/v=285 m ; t=14.14 d ; D=4.91 m²/s and v=1470 m/d .

References

- BEHRENS, H.; MOSER, H. & E. WILDNER. 1977. Investigation of ground water flow with the aid of Indium-EDTA complex using neutron activation for the determination of the tracer .J. Radioanalytical Chemistry, 38; 491498.
- GASPAR, E.; FARCASIU, M.; STANESCU, S.P. & S. SPIRIDON. 1984 Nuclear methods for karst hydrology investigation. Theoretical and Applied karstology,1;207-214.
- GASPAR, E.; STANESCU, S.P.; ORASEANU, I.; FARCASIUM. & S. SPIRIDON. 1985. The behaviour of In-EDTA as a tracer for karst water research. Theoretical and Applied Karstology,2;149-156.
- MALOSZEWSKI, P. & A. ZUBER.1984. Interpretation of artificial and environmental tracers in fissured rocks with a porous matrix Proc. Int. Symp. Isotope Hydrology, IAEA. Vienna. 635-652.
- PRZEWLOCKI, K. & Y. YURTSEVER. 1974. Some conceptual mathematical models and digital simulation systems. Proc. Int. Symp. Isotope Techniques in Groundwater Hydrology, vol II, IAEA, Vienna.425-442.
- YURTSEVER, Y. & B.R. PAYNE. 1978. A digital simulation approach for a tracer case in hydrogeological systems . Proc. Second Int. Conf. on Finite Elements in Water Resources, London. 165-182.
- ZUBER, A. 1974. Theoretical possibilities of the two well pulse method. Isotope Techniques in Groundwater Hydrology IAEA, Vienna.1974.

Le Transport de matière dans les aquifères karstiques

par Valérie Plagnes,

BRGM, Direction de la Recherche, Dép. Hydrologie-Géochimie et Transferts
1039 rue Pinville, 34000 Montpellier, France

Abstract

How functioning (behaviour) and structure of karstic aquifers can be distinguished by studying the mass transport (geochemistry, natural tracing)? How this characterisation complete the study of energy transfert (hydrodynamical methods)? The aim of this purpose is to try to answer these questions. In fact, mass transport results in the competition between several physical (convection, hydrodispersion) and chemical (dissolution...) phenomena from which we try to define their contribution to karstic underground flows.

To complete this theoretical approach, a multi-disciplinary study has been realized on the Larzac Plateau (Aveyron, France). Since the last five years, we collected many hydrogeochemical data on the most important karstic springs draining the area. The most significative results are presented.

Résumé

Comment caractériser le fonctionnement et la structure des aquifères karstiques par l'étude du transport de matière (géochimie, traçage naturel)? En quoi cette caractérisation diffère et complète celle réalisée par l'étude du transfert d'énergie (hydrodynamique)? L'objectif de notre étude est de répondre à ces questions. En effet, le transport de masse résulte de la compétition de plusieurs processus physiques (convection, hydrodispersion) et chimiques (dissolution) dont nous cherchons à définir l'importance dans les écoulements souterrains karstiques.

Ces recherches reposent, en plus d'une approche théorique, sur une étude multidisciplinaire réalisée sur le Causse du Larzac (Aveyron, France). De nombreuses données hydrogéochimiques ont été acquises ces dernières années sur les principales sources karstiques qui drainent le plateau. Les résultats les plus significatifs seront présentés. Une confrontation avec les données existant par ailleurs conduira à une tentative de généralisation de ces résultats à l'étude des systèmes karstiques.

1. Introduction

L'étude du karst impose de reconnaître sa spécificité et nécessite par conséquent d'employer des méthodes particulières adaptées à cette spécificité. Puisque la structure du réservoir ne peut pas être déterminée a priori, l'aquifère karstique doit être considéré dans sa totalité et étudié au moyen de méthodes globales visant à comprendre son fonctionnement. La méthodologie d'étude retenue s'appuie donc sur une **approche hydrogéologique fonctionnelle**. C'est pourquoi l'étude des systèmes karstiques pour l'hydrogéologue, repose en principe, essentiellement sur l'analyse des écoulements aux exutoires de ces systèmes.

Deux types de transferts caractérisent ces écoulements :

- **Le transfert d'énergie** qui correspond au passage d'une onde de pression à travers le système. A cette variation de pression est associée une modification du débit à l'exutoire et de niveau en tout point de la zone noyée. Les méthodes hydrodynamiques (débit classés, analyse des courbes de récession, analyses corrélatoires et spectrales...) sont utilisées pour étudier ces variations.
- **Le transfert de matière ou transport** qui correspond au passage effectif de l'eau. Ce deuxième type de transfert est lié au précédent, mais ne lui est pas nécessairement corrélé. Les traçages artificiels et l'hydrogéochimie (traçages naturels) sont utilisés pour étudier ces déplacements d'eau.

A la suite de J. MARGAT, A. MANGIN (1975) nommait **transfert** le transfert d'énergie et **transit** le transfert de masse (in BAKALOWICZ, 1975). Notons que transfert d'énergie et transport sont deux phénomènes distincts qui s'appliquent à des variables différentes (variations de débit et variations chimiques). Bien qu'ils ne soient pas régis par les mêmes lois et qu'ils possèdent chacun leur propre évolution, ces deux phénomènes ne sont pas pour autant indépendants. En effet, c'est le transfert qui provoque en général le transport. Pourtant, les variations chimiques dues au transfert de masse ne sont pas toutes causées par les modifications du débit. Seuls les processus déterminant les variations du transport seront considérés ici. Après les avoir recensés, nous verrons quels sont ceux que les différents traceurs chimiques permettent de caractériser.

2. Bilan théorique des transferts de matière

Au cours du cycle hydrologique, la composition chimique de l'eau qui s'écoule aux exutoires des aquifères karstiques peut présenter des variations remarquables. La plupart d'entre elles sont déterminées par la succession des événements hydrologiques qui modifient la quantité et la qualité de l'eau présente dans l'aquifère. Mais d'autres phénomènes entrent en jeu et particulièrement les processus physico-chimiques internes au système karstique. En effet, les cinétiques des réactions chimiques qui se produisent dans l'aquifère sont du même ordre de grandeur que les vitesses d'écoulement. On retrouve donc, en plus des phénomènes hydrodispersifs classiques (dispersion,

diffusion...), des mécanismes spécifiques au milieu karstique (dissolution, précipitation de carbonates).

2.1. La dissolution des calcaires

La chimie des carbonates a suscité depuis longtemps l'intérêt de nombreux chercheurs parmi lesquels on note : H. ROQUES (1962), M. BAKALOWICZ (1979) et W. DREYBRODT (1988) entre autres.

Il en résulte que "*l'anhydride carbonique apparaît comme le moteur de la dissolution des carbonates*" (BAKALOWICZ, 1979). C'est pourquoi l'état du système calco-carbonique vis à vis de l'équilibre détermine le potentiel d'une solution à dissoudre ou précipiter des carbonates. Cet équilibre entre les trois phases du système calco-carbonique est décrit par un couple de variables : la pCO_2 équilibrante et le dpH ou **Indice de Saturation vis à vis de la Calcite**. La cinétique de la réaction est longue et compliquée.

Il en résulte que la dissolution des calcaires dépend :

- de la quantité de CO_2 dissous dans l'eau,
- du temps de réaction entre l'eau et la roche, plusieurs facteurs entrent alors en jeu :
 - la cinétique des réactions chimiques,
 - les phénomènes physiques qui conditionnent l'état de la solution à l'interface liquide-solide ainsi que la surface de contact,
 - et surtout la vitesse des écoulements dans le système.

Tous ces phénomènes sont à tout moment en compétition. Leur interaction génère des eaux géochimiquement différentes selon les zones d'acquisition de la minéralisation (épikarst, zone d'infiltration, zone noyée) selon les temps de contact, les vitesses d'écoulement et les possibilités de mélange.

2.2. Les phénomènes physiques qui interviennent sur le transport

De nombreux auteurs les ont étudiés plus particulièrement en hydrogéologie : POREL (1988), HANICH (1991), MEUS (1993) et d'autres encore... Les deux principaux phénomènes rencontrés sont la convection et la dispersion.

La convection

Elle concerne le mouvement du fluide lui-même qui entraîne les éléments dissous suivant sa vitesse propre. Cette vitesse est elle-même soumise à une forte variabilité à la fois spatiale (vitesse différente selon les éléments de la structure karstique parcourus) et temporelle (circulations beaucoup plus rapides en hautes eaux qu'en étiage).

Bien qu'il ne puisse être dissocié des effets de la cinétique chimique, ce phénomène conditionne le transport de masse. En effet, il permet le renouvellement de la couche d'eau en contact avec la roche (maintien d'un gradient de concentration) et il assure l'exportation des matières dissoutes. Si les déplacements de l'eau sont suffisamment lents pour que les réactions chimiques atteignent l'équilibre, alors l'eau qui circule ne réagit plus avec son environnement. Par contre, si les écoulements sont plus rapides que les cinétiques chimiques, les différents traceurs de l'eau ne seront pas équilibrés avec leur milieu encaissant.

Ce déséquilibre renseigne sur certaines des conditions d'écoulement à l'intérieur du système.

La dispersion hydrodynamique

Elle concerne seulement ce qui se passe dans la phase mobile du fluide. Sa contribution est relative face à l'importance des mouvements convectifs, ces processus feront donc l'objet d'une attention particulière dès lors que les écoulements sont suffisamment lents. On distingue :

- **la diffusion moléculaire** : transfert de matière qui tend à équilibrer les concentrations entre les différentes parties d'un fluide selon les gradients de concentration. Ce phénomène peut être négligé dans de nombreux cas. Toutefois, comme en milieu karstique peuvent coexister des "paquets d'eaux" peu ou pas mélangés possédant une origine différente, la diffusion moléculaire doit être prise en compte.
- **la dispersion cinématique** : due à la variabilité des vitesses d'écoulement. C'est la structure du milieu qui est responsable de ces modifications, ce phénomène est donc accentué par la forte hétérogénéité des aquifères karstiques.

Des **dilutions** peuvent aussi perturber les réactions chimiques en cours. De même, des phénomènes d'**adsorption** et de **désorption** de traceur à la surface d'une phase solide peuvent intervenir sur le transport de masse.

2.3. Conclusion

Que l'on étudie de longues chroniques ou seulement l'impact d'un événement hydrologique de courte durée (crue), aucune méthode basée sur l'interprétation des données hydrochimiques ne permet, en l'état actuel des connaissances, d'appréhender réellement le fonctionnement des karsts en révélant l'importance relative de chacun des processus intervenant sur le transport. La décomposition chimique de l'hydrogramme de crue des exutoires karstiques (BLAVOUX et MUDRY, 1983; MUDRY, 1987), qui est une méthode communément employée, ne peut donner d'informations sur ces phénomènes puisqu'elle tente d'expliquer les variations du chimisme par le seul phénomène de mélange entre des eaux d'origines différentes (eau matricielle et eau de ruissellement souterrain). Aucun des processus physico-chimiques décrits ci-dessus n'est en effet pris en compte. Il est alors impossible, pour la plupart des cas, d'évaluer la contribution des conditions d'écoulement face aux processus chimiques internes au système dans les variations du chimisme aux exutoires karstiques.

3. Les différents traceurs hydrochimiques : de précieux informateurs

Les variations du chimisme aux exutoires renseignent à la fois sur le fonctionnement et la structure de l'aquifère. Les informations fonctionnelles sont plutôt liées à une notion de temps (vitesse d'écoulement, temps de séjour, inertie du système...), celles relatives à la structure sont davantage liées à la notion d'espace (zone d'acquisition du traceur,

localisation des zones d'infiltration préférentielle, estimation des zones de réserves...). La plupart du temps, ces deux types d'informations sont intimement liés. Le tableau I résume l'apport de chaque traceur hydrochimique à la connaissance de l'aquifère karstique. A tout moment, les informations

relatives à la structure et au fonctionnement de la zone noyée des karsts sont liées. De plus, un même traceur peut marquer plusieurs phénomènes différents.

Traceur	Lieu d'acquisition	Information apportée
Cond. électrique	tout l'aquifère	temps de séjour, milieu encaissant
Température	tout l'aquifère	origine profonde ou superficielle de l'eau, vitesse de circulation, temps de séjour
dpH	zone d'infiltration	vitesse de circulation (convection), temps de séjour (cinétique)
pCO ₂	épikarst et sols	vitesse de circulation (convection), temps de séjour (cinétique)
Mg	zone noyée, encaissant dolomitique (épikarst, ZN)	temps de séjour de l'eau, géologie du réservoir, stockage dans un épikarst dolomitique...
SiO ₂	zone noyée	temps de séjour, colmatage par remplissage détritique
SO ₄	zone noyée, encaissant géologique	temps de séjour de l'eau, géologie du réservoir (gypse, anhydrite)
Cl	épikarst, encaissant géologique	caractérise la zone d'infiltration (reconcentration par ETR), indice de pollutions, géologie du réservoir (évaporites)
NO ₃	épikarst et sols	conditions d'infiltration, indice de pollutions
Na et K	épikarst	caractérise la zone d'infiltration (reconcentration par ETR), indice de pollutions, adsorption, désorption
¹⁸ O	pluie	temps de séjour, altitude de la zone d'infiltration
³ H	pluie	temps de séjour
O ₂ dissous	pluie	conditions d'écoulement (surface libre ou captive)

Tableau I : Quels types d'informations apportent les différents traceurs chimiques ?

4. Le Karst du Larzac : exemple

Quelques 800 échantillons ont été prélevés ces dernières années sur les sources karstiques qui drainent le Causse du Larzac (au pas hebdomadaire pour les sept principales et mensuel pour dix autres). Chaque échantillon est caractérisé par des variables mesurées (conductivité électrique, T, pH, HCO₃, Ca, Mg, Na, K, Cl, NO₃, SO₄, SiO₂) et des variables calculées (dpH, pCO₂, IEC...).

Pour un même événement climatique, les différentes sources suivies ne présentent pas toujours le même comportement hydrochimique. Cette différence peut être observée non seulement sur la minéralisation globale de l'eau (Figure 1) mais aussi sur l'évolution des teneurs en certains éléments chimiques (Figure 2).

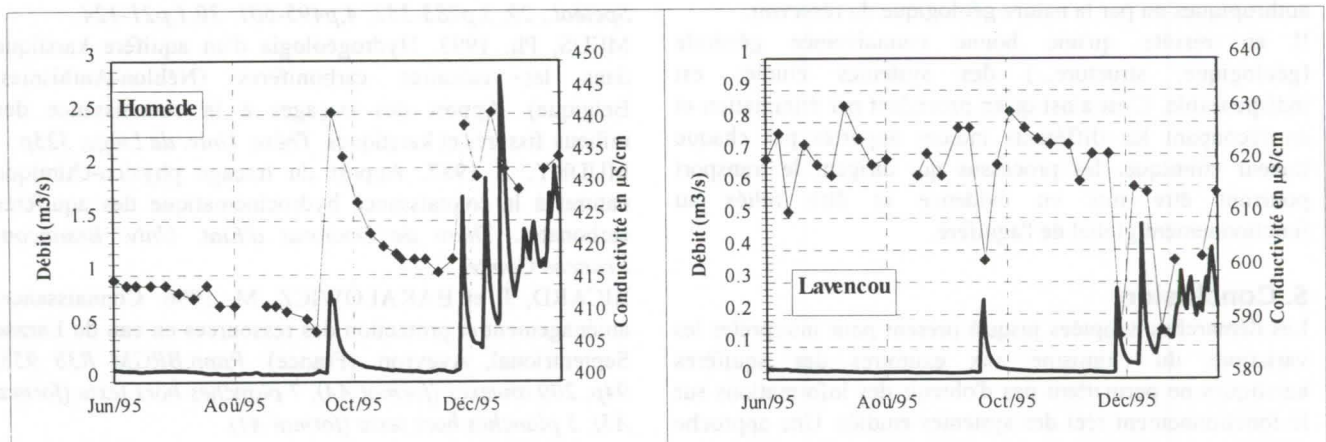

Figure 1 : Variation de la conductivité électrique pour deux sources karstiques du Larzac.

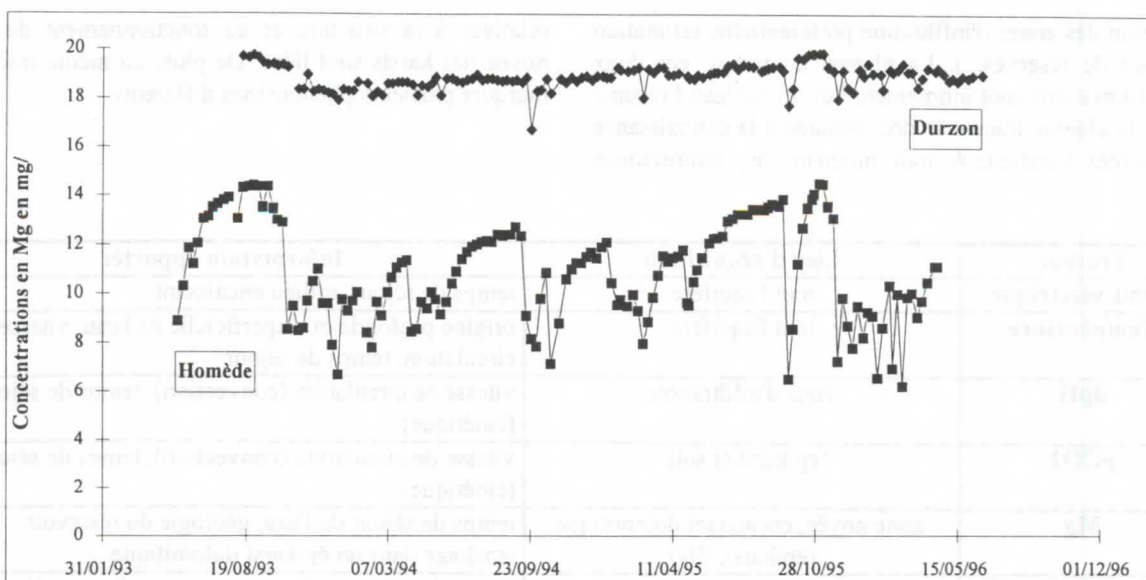

Figure 2 : Evolution des teneurs en Mg pour deux sources karstiques du Larzac

La variabilité des teneurs en magnésium d'une source à l'autre peut être reliée à de nombreux facteurs :

- existence de réserves dans la zone noyée de l'aquifère,
- stockage suffisamment long dans l'aquifère épikarstique dolomitique,
- effet de la dilution avec des eaux d'infiltration rapide,
- augmentation du temps de séjour de l'eau dans la zone noyée.

Le magnésium marque à lui seul de nombreux phénomènes qui peuvent permettre d'appréhender le fonctionnement de la zone noyée des karsts étudiés. Toutefois, ils sont la plupart du temps superposés et bien qu'ils soient tous à prendre en compte, leur importance est relative d'un système karstique à un autre. Il n'est donc pour l'instant pas possible de distinguer la participation de chacun de ces phénomènes dans la composition chimique de l'écoulement.

Nous sommes confrontés au même problème en ce qui concerne les autres traceurs chimiques. Par exemple, les chlorures peuvent caractériser l'eau en provenance de la zone d'infiltration, mais aussi être apportés par des activités anthropiques ou par la nature géologique du réservoir.

Il en résulte qu'une bonne connaissance générale (géologique, structure...) des systèmes étudiés est indispensable. C'est ainsi qu'en procédant par élimination et en recoupant les différents indices apportés par chaque traceur chimique, les processus qui dirigent le transport pourront être mis en évidence et être reliés au fonctionnement global de l'aquifère.

5. Conclusion

Les démarches adoptées jusqu'à présent pour interpréter les variations du chimisme aux exutoires des aquifères karstiques ne permettent pas d'obtenir des informations sur le fonctionnement réel des systèmes étudiés. Une approche différente semble alors nécessaire. Elle devra prendre en compte tous les processus physico-chimiques qui se produisent à l'intérieur des karsts pour rendre compte de la spécificité de ce milieu.

Références

- BAKALOWICZ, M. 1975. L'évolution du chimisme de l'eau d'une source karstique. *3eme convegno internazionale sulle acque sotterranee, Palermo, 1-5 novembre 1975.*
- BAKALOWICZ, M. 1979. Contribution de la géochimie des eaux à la connaissance de l'aquifère karstique et de la karstification. *Thèse de Doctorat d'Etat ès Sci. nat, Univ. Paris 6, 269p.*
- BLAVOUX, B., MUDRY, J. 1983. Séparation des composantes de l'écoulement d'un exutoire karstique à l'aide des méthodes physico-chimiques. *Hydrogéologie, 4, 1983, pp 269-278, 8 fig, 1 tabl.*
- DREYBRODT, W. 1988. Processes in karst systems. *Ed. Springer-Verlag, Berlin, 288p, 184 fig.*
- HANICH, L. 1991. Les traçages d'essai en aquifère hétérogène : méthodes, intérêt et limites. *Thèse Univ. Lille-Flandre-Artois, 155p.*
- MANGIN, A. 1975. Contribution à l'étude hydrodynamique des aquifères karstiques. *Thèse Doctorat Sci. nat., in Ann. Spéléol., 29, 3, p283-332; 4, p495-601; 30, 1, p21-124.*
- MEUS, Ph. 1993. Hydrogéologie d'un aquifère karstique dans les calcaires carbonifères (Néblon-Anthismes, Belgique). Apport des traçages à la connaissance des milieux fissurés et karstiques. *Thèse, Univ. de Liège, 323p.*
- MUDRY, J. 1987. Apport du traçage physico-chimique naturel à la connaissance hydrocinématique des aquifères carbonatés. *Thèse de Doctorat d'Etat, Univ. Besançon-Franche Comté.*
- RICARD, J. et BAKALOWICZ, M. 1996. Connaissance, aménagement et protection des ressources en eau du Larzac Septentrional, Aveyron. (France). *Rapp.BRGM R38 953, 94p, 200 annexes (format A4), 7 planches hors texte (format A3), 5 planches hors texte (format A1).*
- ROQUES, H. 1962. Considérations théoriques sur la chimie des carbonates. *Ann. Spéléol., 17, 1, p11-41; 2, p241-284; 3, p463-467.*

Modelling of suckwell recharge in carbonate terrain

by Chris C. Smart

Department of Geography, University of Western Ontario, London, Ontario, N6A 5C2, Canada. SMART@SSCL.UWO.CA

Abstract

Suckwells are artificial shafts excavated in soft carbonates to relieve surface flooding throughout the Caribbean. They significantly enhance ground water recharge, but may also convey surface contaminants directly to the unsaturated zone. Physically based models of suckwell recharge are difficult to implement. A simple linear model of suckwell drainage through the base of the well shows that drainage rate is determined by readily measured "nominal volume" and a recharge coefficient. Field slug injections confirm the generality of the model, but demonstrate systematic departure from predictions; more water is drained from the borehole early in the test, and less later. The error is interpreted as indicating radial drainage and return of some fraction of radially discharged water. The basal permeability coefficient can be determined by stepwise analysis of the data to zero head. Radial discharge and permeability can be estimated at maximum head by subtracting calculated basal drainage from observed total drainage. In general, the radial permeability coefficient is less than the basal permeability coefficient. However, the magnitude, time-constant and direction of the radial drainage needs direct investigation. There are indications of significant heterogeneity in the radial permeability, and there may be dependence on antecedent moisture. Higher quality test data are necessary to adequately resolve the problem

1. Introduction

Suckwells are artificial vertical shafts excavated in soft coral rock throughout the Caribbean to relieve ponding and flooding. They are commonly located in depressions or intermittent channels, and are excavated until a suitable enlarged fissure or "suck" is found. Suck wells are typically cylindrical in form, 2-20 m deep and 0.5-0.75 m in radius, but may enlarge at their base. They are commonly protected by a low wall or grid at the surface and masonry-lined down to solid rock. They typically contain sediment, organic flood debris, and garbage.

Suckwells can significantly enhance ground water resources. By transmitting surface water rapidly to depths near the water table, they enhance ground water recharge and reduce evaporative losses. Interception of surface streams may prevent discharge of fresh water to the ocean. However, Suckwells also allow surface water contaminants more direct transmission to the aquifer than under natural, soil-mediated recharge. Increasing pressure on water resources makes it imperative to develop improved techniques of management and assessment. Smart and Ketterling (1997) report on suckwell management strategy. The present paper attempts to increase understanding of Suckwell hydrology by development of a drainage model.

2. Suckwell model

Point recharge in a highly heterogeneous unsaturated zone is beyond the scope of conventional ground water models. In addition, the large volume, rough-hewn form and unsaturated position of Suckwells combined with uncertain moisture content confound their assessment using any conventional ground water testing technique. However, it is possible to develop simple models of Suckwells as a guide to understanding and management.

A suckwell can be considered a permeable cylinder of length h_c , radius r and basal radius r_b , filled with water to height h (Figure 1). Surface runoff enters as Q_{in} and the suckwell drains (Q_{out}) by basal (Q_b) and radial (Q_r) infiltration.

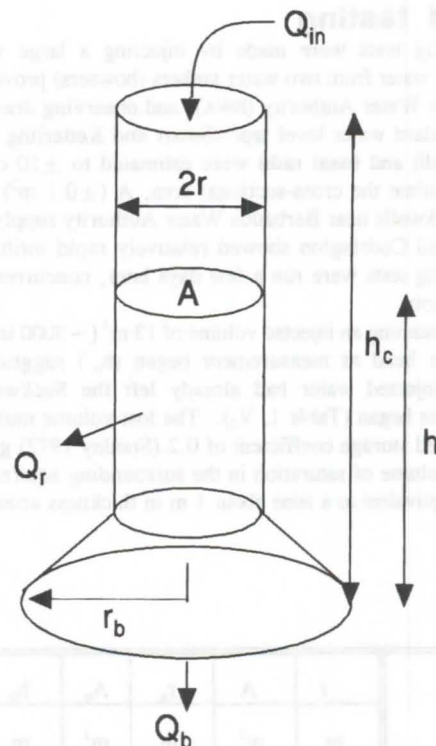

Figure 1. Model Suckwell

During a runoff event the suckwell fills when Q_{in} exceeds Q_{out} . Consider a simple field slug test, where a quantity of water has been injected into the well and is draining away. Drainage is dependent on hydraulic gradients and unsaturated hydraulic conductivities which will vary throughout the well and with time. The key physical variables defy field monitoring, and a simpler approach is required if widespread application is anticipated.

Suckwells are constructed to drain through their beds into the basal fracture. This suggests a simpler approach might be to consider the suckwell as a cylinder with a leaky bed and

impermeable walls. The head, h is the primary driving force and the Q_r is ignored. Alluvium on the floor implies Q_b will be laminar so that the suckwell can be considered a *linear reservoir* (e.g. Chow, 1988) in which

$$Q_b = \pi r_b^2 \alpha_b h \quad (1)$$

where α_b is a basal infiltration coefficient with dimension of t^{-1} . A useful management index is basal discharge at capacity ($h=h_c$) which is given by $\alpha_b V_c$ where $V_c (= \pi r_b^2 h_c)$ is the "nominal volume" of the suckwell.

Linear reservoir drainage is exponential in form (e.g. Chow 1988), so that

$$h_t = h_0 \exp(-\alpha_b (r_b / r)^2 t) \quad (2)$$

The expected exponential form of water level during drainage is testable by observation. Significant departure from exponential form will indicate weakness in the simple basal drainage model. Equation (2) can be linearised, allowing $\alpha' (= \alpha_b (r_b / r)^2)$ to be obtained by linear regression. $1/\alpha'$ constitutes a "residence time". Measurements of r and r_b allow α_b to be estimated from passive drawdown data.

3. Field testing

Slug tests were made by injecting a large volume ($\sim 13m^3$) of water from two water tankers (browsers) provided by the Barbados Water Authority (BWA), and observing drawdown using a standard water level tape (Smart and Ketterling 1997). Suckwell radii and basal radii were estimated to ± 10 cm and used to calculate the cross-sectional area, A ($\pm 0.1 m^2$). Tests made in Suckwells near Barbados Water Authority supply wells at Buttals and Codrington showed relatively rapid infiltration. Replicate slug tests were run a few days later, concurrent with tracer injection.

Assuming an injected volume of $13 m^3$ (~ 3000 imperial gallons), the head as measurement began (h_0) suggests that $\sim 50\%$ of injected water had already left the Suckwells as measurements began (Table 1, V_0). The lost volume multiplied by an assumed storage coefficient of 0.2 (Stanley 1972) gave an equivalent volume of saturation in the surrounding aquifer from $24-44 m^3$, equivalent to a zone about 1 m in thickness around the well.

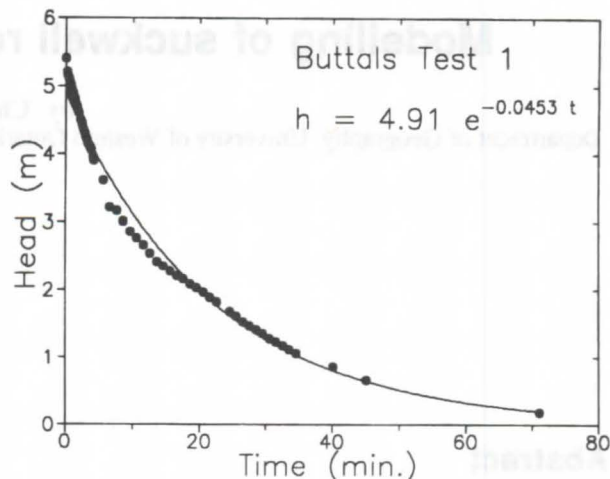

Figure 2. Example of suckwell drawdown data for Buttals Test 1, with fitted exponential curve.

Exponential fits to the corrected water level ($h(t)$ in m) against time (t in minutes) gave correlation coefficients (r^2) in excess of 0.99 indicating good exponential form (e.g., Figure 2). α' values obtained were from 0.04 to 0.08 min^{-1} (Table 1), giving residence times ($1/\alpha'$) from 12 to 22 min. α_b varied between .01 and .08 min^{-1} . Higher values on second tests suggest the antecedent moisture increases the basal permeability. The results support the simple steady state basal drainage model.

4. Analysis

Inspection of the drawdown curves suggests that the model predictions systematically depart from observations. Figure 3 shows the residuals between observed water level and the exponential model are initially positive, become negative at heads of 3.1 and 4.2 m for Buttals and Codrington respectively, then becoming positive at 2 and 1.2 m. This pattern suggests that radial flow is active near maximum head, and *reverses* as water level falls in the suckwell. Residual distribution appears to vary more between test sites than within replicate tests at each site. This, despite different initial volumes and antecedent conditions suggests that storage may well be influenced by zones of preferred radial permeability.

Test	r	A	r_b	A_b	h_0	V_0	α'	α_b	$\alpha_b(\infty)$	$\alpha_r(0)$	h'
	m	m^2	m	m^2	m	m^3	min^{-1}	min^{-1}	min^{-1}	min^{-1}	m
Buttals 1	0.75	1.8	1.2	4.5	4.91	7.7	0.0453	0.0177	0.018	0.018	2.45
Buttals 2	0.75	1.8	1.2	4.5	4.72	8.2	0.0517	0.0202	0.023	0.0060	7.36
Codrington 1	0.6	1.1	0.6	1.1	4.28	4.2	0.0622	0.0622	0.060	0.010	6.6
Codrington 2	0.6	1.1	0.6	1.1	4.50	4.9	0.0796	0.0796	0.07?	0.002?	38.5?

Table 1: Results of the suckwell injection tests. r and A , and r_b and A_b are well and basal radius and area respectively. h_0 is the initial head at time zero and V_0 is the initial volume at the start of the test. α' was determined from regression; α_b is the overall basal infiltration coefficient. $\alpha_b(\infty)$ is the basal infiltration coefficient obtained by extrapolation. $\alpha_r(0)$ is the radial infiltration coefficient obtained at the start of observations. h' is the head above which radial discharge dominates.

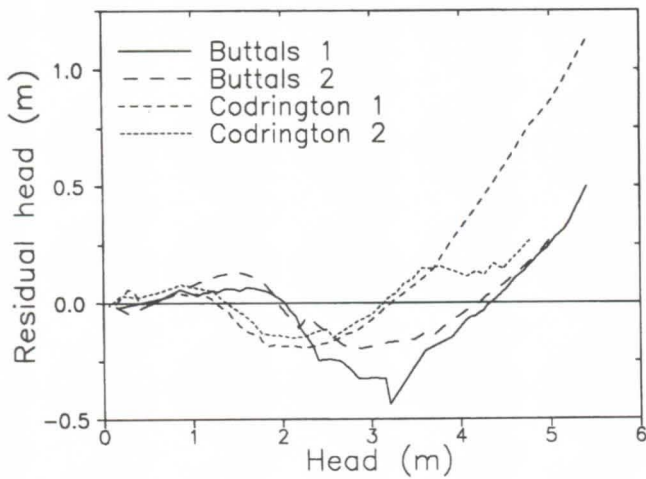

Figure 3. Distribution of residual head from exponential fit to suckwell slug tests.

An abundance of water dripping from the walls as head falls suggests that the concept of temporary radial storage is not unreasonable, but its magnitude is uncertain. Ignoring heterogeneity, consider the model in Figure 1. The radial discharge Q_r is obtained by integration of the hydraulic head over the range zero to h , to give

$$Q_r = \pi r \alpha_r h^2 \quad (3)$$

Equations (1) and (3) show that Q_r scales with rh^2 , while Q_b scales with $r_b^2 h$. Therefore the relative influence of Q_r is minimised at low head. Providing the radial reflux is not significant at the last stages of drawdown, it may be possible to extract a reasonable estimate of α_b from the last few data points. Every observational pair $\{(h_i, t_i), (h_{i+1}, t_{i+1})\}$ allows an estimate of the basal permeability coefficient

$$\alpha_b = (r/r_b)^2 \ln(h_{i+1}/h_i)/(t_{i+1}-t_i) \quad (4)$$

Figure 4 shows a plot of stepwise estimates of α_b against head for the first test at Buttals. At initial head, the α_b value is $\sim 0.068 \text{ min}^{-1}$, but includes maximal rates of Q_r . At the limit as $h \rightarrow 0$, α_b approaches 0.018 min^{-1} , and this value will be incorporated into further modelling. The minimum value at $\sim 2\text{m}$ is assumed to result from active radial reflux ($Q_r < 0$). The step- α curves all show considerable irregularity. Part of this is not unexpected error in measurement and is characteristically oscillatory as both time and depth are "closed" measurements; e.g., a positive error forces a serial negative error. However, both Buttals tests show irregularity at around four metres, possibly a zone of heterogeneity.

Total discharge can be estimated from the drawdown data $Q_T = \pi r^2 \delta h / \delta t$. Q_b can be estimated from equation (1) using the limiting value of $\alpha_b(\infty) = 0.018 \text{ min}^{-1}$ estimated above. Q_r can then be calculated as the residual; $Q_r = Q_T - Q_b$. Figure 5 shows the respective discharge estimates for Buttals test 1. The irregular nature of Q_T (and Q_r) arises from the sensitivity of the step method to errors in measurement of h . Q_r appears to become negative at around three metres head, when residuals are most negative. α_r is estimated from the first data point and shown in Table 1 as $\alpha_r(0)$ values are somewhat sensitive to selection of α_b , but are on the same order or smaller.

Simulations of suckwell recharge and drainage in response to a storm do not incorporate either radial reflux or antecedent moisture, as there is not yet any effective way of parameterising these processes. Interestingly, the radial discharge dominates above a critical height, considerably below the top of the suck well. The critical height, h' can be estimate by equating (1) and (2) and solving for $h' = r_b^2 \alpha_b / \alpha_r$ (Table 1).

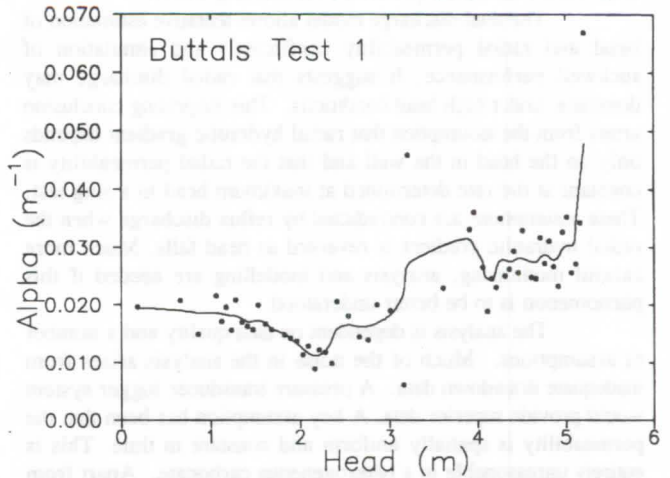

Figure 4. Stepwise estimates of α_b , basal permeability coefficient from observed drawdown data. A smoothed curve has been fitted through the points.

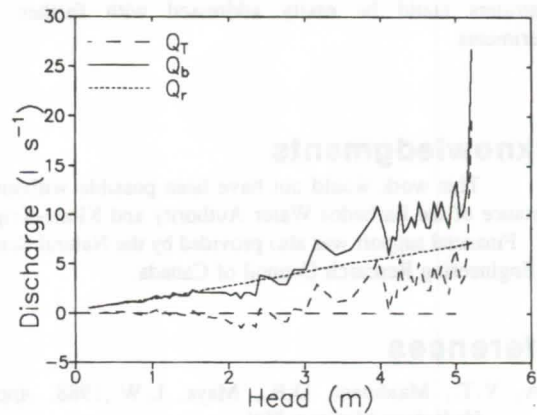

Figure 5. Observed total discharge Q_T for Buttals test 1, with derived basal (Q_b) and radial discharge Q_r .

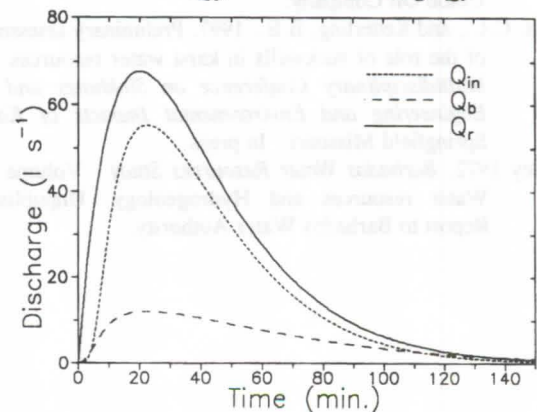

Figure 6. Simulated storm drainage through Buttals Suckwell based on Test 1 parameters.

5. Conclusions

The assumption of dominant basal permeability leads to a useful first approximation of suckwell drainage, allowing practical assessment and classification of Suckwells in terms of their residence time. It also leads directly to management principles from which volume critical and contaminant critical sites can be identified (Smart and Ketterling 1997).

The dual discharge model allows tentative estimation of basal and radial permeability coefficients and simulation of suckwell performance. It suggests that radial discharge may dominate under high head conditions. This surprising conclusion arises from the assumption that radial hydraulic gradient depends only on the head in the well and that the radial permeability is constant at the rate determined at maximum head in a slug test. These assumptions are contradicted by reflux discharge when the radial hydraulic gradient is reversed as head falls. Much more careful monitoring, analysis and modelling are needed if this phenomenon is to be better understood.

The analysis is dependent on data quality and a number of assumptions. Much of the noise in the analysis arises from inadequate drawdown data. A pressure transducer-logger system would provide superior data. A key assumption has been that the permeability is spatially uniform and constant in time. This is entirely unreasonable in a heterogeneous carbonate. Apart from the basal fracture to which the well is connected, there is evidence that there are zones of enhanced permeability down the well column. Better drawdown data might allow identification of these zones. Replicate tests showed higher basal permeability coefficient which implies that the permeability terms depend on antecedent moisture. Correspondingly, they would be expected to evolve during the duration of the test. Many of these constraints could be easily addressed with further field experiments.

Acknowledgments

This work would not have been possible without the assistance of the Barbados Water Authority and Klone-Krippen Ltd. Financial support was also provided by the Natural Science and Engineering Research Council of Canada.

References

- Chow, V.T., Maidment, D.R., Mays, L.W., 1988. *Applied Hydrology* McGraw Hill.
- Freeze, R.A. and Cherry, J. C., 1981. *Ground water*. Prentice Hall.
- Senn, A. 1946. *Geological investigations of the ground-water resources of Barbados, B.W.I.*, Report to the British Union Oil Company.
- Smart, C.C., and Ketterling, B.B., 1997. Preliminary assessment of the role of suckwells in karst water resources. *VI Multidisciplinary Conference on Sinkholes and the Engineering and Environmental Impacts of Karst*, Springfield Missouri. In press.
- Stanley 1972. *Barbados Water Resources Study*. Volume III, Water resources and Hydrogeology. Unpublished Report to Barbados Water Authority.

The Interpretation of a High Water Tracer Test in the Danube-Aach-System (Western Swabian Alb, Germany)

Andreas Werner¹, Heinz Hötzl²

Department of Applied Geology, University of Karlsruhe, Kaiserstr. 12, D-76128 Karlsruhe

Werner Käß

Mühlematten 5, D-79224 Umkirch

Abstract

A multi-tracer test was carried out 1995 in the Danube-Aach-System (Western Swabian Alb, Germany) during a high water event. The evaluation was performed with different model approaches. The comparison of the results has shown that the used analytical models are able to describe mathematically the breakthrough curves of the used tracers. The tracer transport could be restricted on convection and dispersion processes. Due to the existing unsteady flow conditions the determined analytical values must be checked with a numerical model.

Zusammenfassung

In der westlichen Schwäbischen Alb (Deutschland) wurde 1995 im Donau-Aach-Gebiet ein Multitracerversuch während eines Hochwasserereignisses durchgeführt. Bei der Auswertung wurden verschiedene Modellansätze vergleichend eingesetzt. Es konnte gezeigt werden, daß die eingesetzten Modelle in der Lage sind die Durchgangskurve der Tracer mathematisch zu beschreiben. Der Transport im Donau-Aach-System unterliegt dabei nur Dispersions- und Konvektionsprozessen. Bei stark instationären Verhältnissen müssen jedoch die analytisch gewonnen Parameter numerisch überprüft werden.

1. Introduction

The Danube-Aach-System is located in the South-West of the Swabian Alb (Germany). The Danube river crosses this region from the West to the East. For about 160-180 days per year the water of the river is vanishing completely. This water reappears in the largest spring of Germany, the Aachquelle (Aach spring). It is located about 12 km south of the main sinking wholes.

Consequently the region is an object of research since a long time (BATSCHKE et al., 1970; HÖTZL, 1991). Thirty-nine tracer experiments have been carried out in the past 120 years. The first quantitative one was already done in 1877 with chloride. About the interpretation of the tests in the area of the main sinking wholes was already reported (WERNER et al., 1997a). In the context of these investigations an additional tracer experiment was done in the summer of 1995. This experiment was carried out as a multi-tracer test. This means that two tracers were injected simultaneously. In the following, the paper reports about the used methods and the resulting problems during the interpretation of the test.

2. The tracer test

In connection of the reinterpretation of the tracer experiments of the Danube-Aach-System (WERNER et al. 1997) an additional test was performed to get more data for the mathematical interpretation. This was necessary because much of the existing data is of qualitatively character. The experiment was started during the time of total water absence of the Danube river followed by a high water event. Two tracers (uranine and lithium) were injected simultaneously (multi-tracer test) for recognising processes, which based on the different transport behaviour of the used tracers.

The input (Table 1) was performed in August 28th, 1995 in the area of the main sinking wholes near Immendingen („Im Brühl“). Firstly, the uranine was injected, immediately (ca. 15 minutes later) followed by the lithium (25kg lithiumchloride). At the same time the detection of the tracers was started with automatically working probe samplers at the Aach spring.

During the injection an increasing Danube water level could be observed. A few hours later the injection wholes were flooded.

Due to this high water the first reappearance of the tracer could be detected after only 22 hours later.

Experiment of 1995	
Injection	„Brühl“ near Immendingen 28. August 1995
Tracers	8 kg Uranine 25 kg Lithium(-chloride)
Detection	Aach Spring 28. August. - 16. September 1995
Distance from „Brühl“	11.8 km
Tracer Recovery	81% Uranine 35% Lithium

Table 1: The tracer experiment of 1995

The breakthrough curves of both tracers (Figure 1) were characterised as a double peak. About 100 hours after the input the tracer concentrations have reached the values of background concentrations (lithium) or minimum detection limit (Uranine). The curve of the high water is shown in Figure 2. The discharge curve of the Danube is formed as two waves. The Aach spring does not reflect such behaviour. The passage through the karst system has a compensating effect.

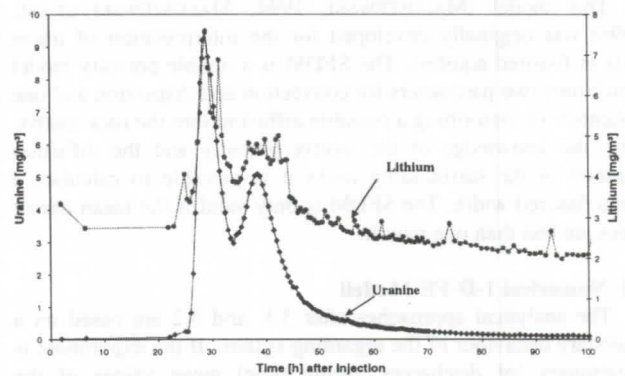

Figure 1: Breakthrough curves of the injected tracers at the Aach Spring

¹Email: andreas.werner@bio-geo.uni-karlsruhe.de

²Email: heinz.hoetzl@bio-geo.uni-karlsruhe.de

The double peak of the uranine breakthrough is not the result of the double wave of the high water. The second flood wave begins nearly at the same time as the second uranine peak. However, the time to flow from the injection place to the Aach spring takes at least about 20 hours.

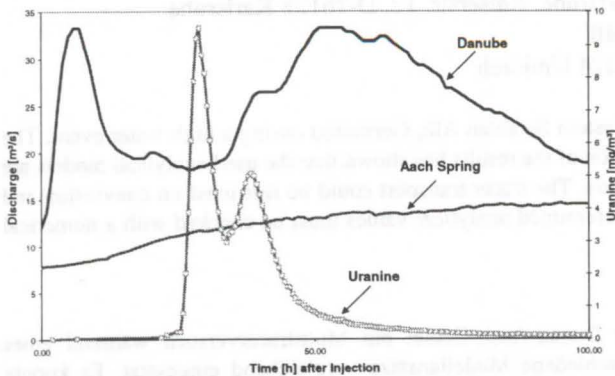

Figure 2: The discharge curves of the Danube and the Aach spring³. The uranine breakthrough curve is shown for comparison.

3. The model approaches

The evaluation of the tracer test was carried out for three aspects:

- Comparison of the both tracers uranine and lithium
- Comparison of two different model approaches during the evaluation of the uranine breakthrough curve
- Comparison of steady and unsteady flow interpretation

Altogether, three different model concepts were used. In the following these methods are characterised briefly. All of the used models are implemented in the computer program „Traci“⁴

3.1. The Multi-Dispersions-Model (MDM)

The Multi-Dispersion-Modell (MALOSZEWSKI ET AL. 1992) is a variation of the classical convection-dispersion model from Lenda & Zuber (1970). The resulting breakthrough curve of the tracer experiment is seen as the outcome of different flow paths. Step by step the breakthrough curves of the individual flow paths and the parameter of convection (mean transit time respectively mean flow velocity) and dispersion (dispersivity) processes are determined. The procedure during the evaluation is described in WERNER ET AL. (1997a). The first application (MALOSZEWSKI ET AL, 1992) in a karstic area was performed in Styria (Austria).

3.2. Single Fissure-Dispersion-Model (SFDM)

This model (MALOSZEWSKI, 1994; MALOSZEWSKI ET AL. 1994) was originally developed for the interpretation of tracer tests in fissured aquifers. The SFDM is a double porosity model which uses two parameters for convection and dispersion and one parameter for describing a possible diffusion into the rock matrix. With the knowledge of the matrix porosity and the diffusion constant of the surrounding rocks it is possible to calculate a mean fissured width. The SFDM is only valid if the mean transit times are less than one month.

3.3. Numerical 1-D-FE-Modell

The analytical approaches after 3.1. and 3.2 are based on a stationary behaviour of the regarding system. If the experiment is instationary (of discharges during time) mean values of the discharge will be used. The numerical model was developed for

checking the analytical determined results. The model itself is described in WERNER ET AL. (1997b).

4. The evaluation of the tracer experiment

4.1. Comparison of the used tracers (Fig. 3)

The multi-tracer test was performed under the intention to detect some possible differences in the transport behaviour of the used tracers. This comparison is only possible under identical hydraulic conditions. Therefore the tracers must be injected simultaneously. For technical reasons it was necessary to inject the tracers successively during this experiment.

The breakthrough curves (Fig. 1) already show the parallel course of both tracers. Be caused by the background concentration of lithium (about 2-3 mg/m³) in the system, the lithium breakthrough curve shows an indistinct behaviour.

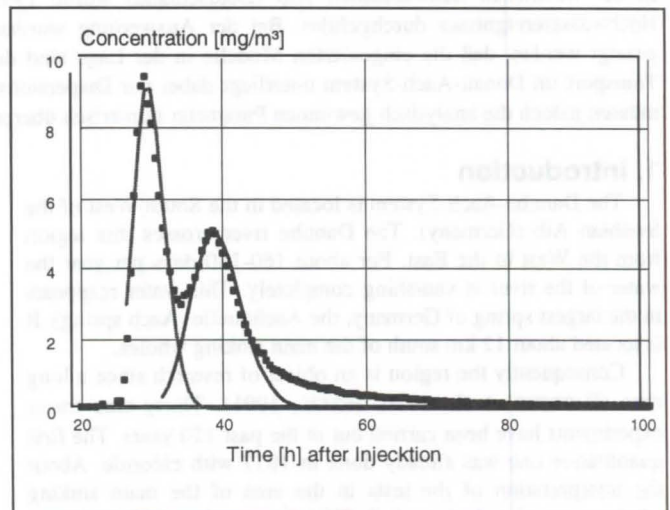

Uranine	PEAK I	PEAK II
Mean transit time [h]:	29.7	39.2
Flow velocity [m/h]:	397	301
Dispersivity [m]:	31	49

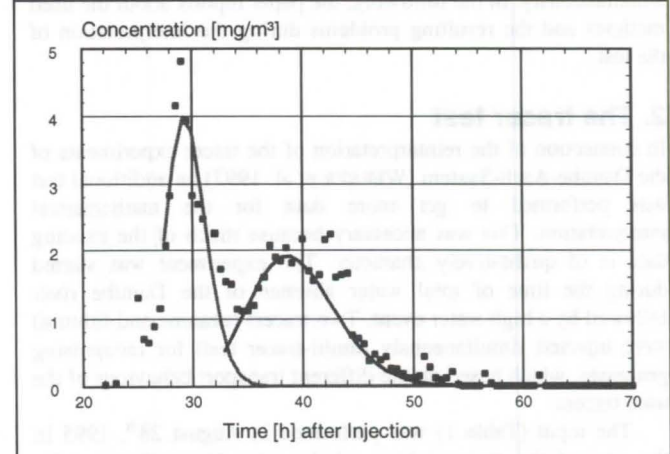

Lithium	PEAK I	PEAK II
Mean transit time [h]:	29.5	39.2
Flow velocity [m/h]:	397	301
Dispersivity [m]:	31.0	59.7

Figure 3.: Results of the evaluation of the Multi-tracer-Test with the MDM (a background value of 2.5 was subtracted from the lithium-values)

The interpretation was performed with the MDM for both tracers. The tailing of the uranine curve was not fitted (see 4.2), because the lithium curve does not show this behaviour. The

³ The discharge data is provided by the Landesanstalt für Umweltschutz (LfU) Baden-Württemberg.

⁴ Demo version of this program are available from the authors

determined parameters (Figure 3) are comparable. There is only a difference in the dispersivity values for the second peak. It is much higher for the lithium as for the uranine peak. The reason is not caused by the transport; the high background values in contrast to the maximal concentration (about 5 mg/m³) are responsible for this effect.

4.2. Evaluation of the uranine breakthrough curve with the MDM and the SFDM

Because of the extreme tailing the uranine breakthrough curve could not be fitted satisfactorily with two fit curves (Fig.3, above). Therefore the SFDM was used next to MDM. The SFDM is able to describe mathematically this kind of tailing effects. The evaluation (Fig. 4) showed that a complete description of the breakthrough curve is possible with both models:

- **MDM:** Fitting of the breakthrough curve by superposition of five single peaks
- **SFDM:** Fitting of the breakthrough curve by two peaks. The first one is calculated using the MDM, the second one using the SFDM

What is now the „right“ model?

From the visual impression and without background knowledge the SFDM seems to be the better one. However, the following reasons show that the fitting with the MDM is more plausible:

- Older tracer tests (WERNER ET AL., 1997, BARCZEWSKI ET AL., 1996) never showed such tailing effects. These experiments were performed under flow conditions with lower flow velocities. All experiments also showed a superposition of at least two flow paths.
- The comparison of the two tracers uranine and lithium yield no different transport behaviour showing that there exist matrix diffusion processes

Therefore, the high water is responsible for the tailing effect of the uranine breakthrough curve. The flood event would imply that the flow takes place in areas of the aquifer, which are normally not participating at the flow system. The several peaks of the total breakthrough curve at the Aach spring resulted from these additional flow paths. The tailing is a result of the overlapping of the peaks of the individual flow paths.

These results, together with the conclusions of 4.1., elucidate that only dispersion and convection processes determine the character of the transport behaviour in the karst system.

4.3. Steady/unsteady flow evaluation of the tracer test

The whole tracer test was characterised by the high water event. On the other hand the evaluations with the analytical solutions were performed with mean values of the discharge. For this reason a numerical model was used in addition to prove the determined analytical results.

The evaluation (Fig. 5) was limited to the first 50 hours of the experiment. The analytical fit with the MDM shows an adequate description of the breakthrough curve (①). As expected, the verification with the numerical model with stationary discharge conditions (mean values) shows the same result (②). The unsteady numerical calculation with the same parameters lead to considerable differences (③). A satisfactory fit is only possible with a modification of the parameters (④).

The differences between the mean transit times are negligible (28.3h c. 29h respectively 39.2h c. 39.8h). The differences of the results of the different models are recognisable for the dispersivity values. The increasing flow velocity during the experiment causes increasing differences in the flow behaviour. This is reflected by the dispersivity values. These differences (31.3m c. 29m respectively. 49.2m c. 80m) must be considered if they are important for the regarding problem.

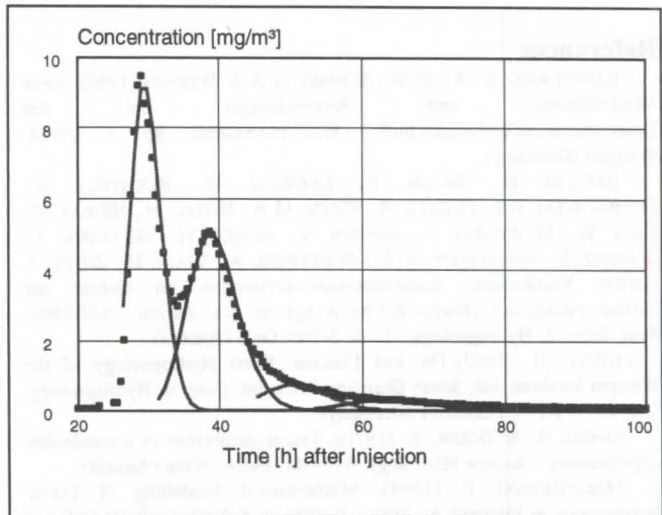

MDM	PEAK I	II	III	IV	V
Mean transit time [h]:	30	39	51	64	77
Flow velocity [m/h]:	397	301	232	184	151
Dispersivity [m]:	31	49	47	50	20

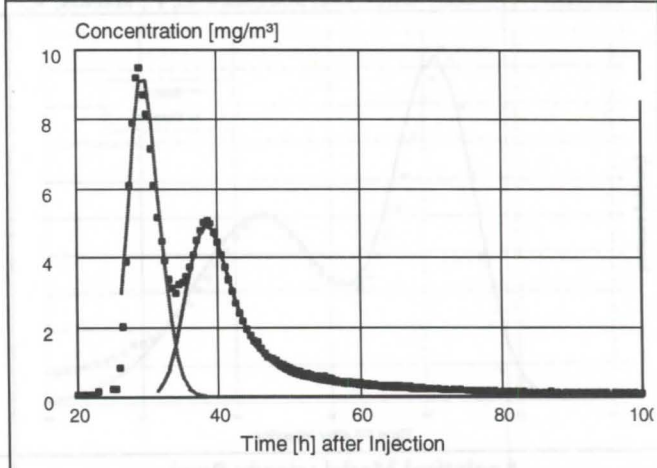

SFDM	PEAK I	PEAK II
	MDM-Model	SFDM-Model
Mean transit time [h]:	30	39
Flow velocity [m/h]:	397	301
Dispersivity [m]:	31	49
Fissure width 2b [mm]	-	2-4

Figure 4.: Results of the evaluation of the uranine breakthrough curve with the MDM and the SFDM

5. Conclusions

The interpretation of karst tracer tests is seldom unequivocal. The experiment in the Danube-Aach-System shows that it is possible to describe the breakthrough curves correctly with different model approaches. The advantages and disadvantages of the different used models are difficult to define. It depends frequently on other results and on background information. The models are on the other hand very important tools for the estimation of the dynamic of a karst system.

The analytical solutions (MDM and SFDM) are suitable for a fast evaluation of a tracer experiment. The determined results are applicable if the boundary conditions of the used model were considered. The MDM is also useful under unsteady flow conditions. For the estimation of the error of the parameter it is necessary to execute a numerical calculation

The determined results are also important for the understanding of the Danube-Aach-System. However, this is not the subject of this paper. It shall be referred to WERNER (1997).

References

BARCZEWSKI, B.; KÄSS, W.; SCHMID, G. & A. WERNER (1996): Neue Möglichkeiten und Anwendungen bei der Grundwassermarkierungstechnik.- Wasserwirtschaft, 86, 1, 20-24, Stuttgart (Germany).

BATSCH H., BAUER, F., BEHRENS, H., BUCHTELA, K., DOMBROWSKI, H.J., GEISLER, R., GEYH, M.A., HÖTZL, H., HRIBAR, F., KÄSS, W., MAIRHOFER, J., MAURIN, V., MOSER, H., NEUMAIER, F., SCHMITZ, J., SCHNITZLER, W.A., SCHREINER, A., VOGG, H., ZÖTZL, J. (1970): Kombinierte Karstwasseruntersuchungen im Gebiet der Donauversickerung (Baden-Württemberg) in den Jahren 1967-1969. Steir. Beitr. Z. Hydrogeologie, 22, S. 5-165, Graz (Austria).

HÖTZL, H. (1992): The lost Danube: Karst Hydrogeology of the Western Swabian Alb, South Germany. IAH, Int. Cont. to Hydrogeology, Vol. 13, 179-194, Hannover (Germany).

LENDI, A. & ZUBER, A. (1970): Tracer dispersion in groundwater experimentes. - Isotope Hydrology, 619-641, IAEA, Wien (Austria).

MALOSZEWSKI, P. (1994): Mathematical Modelling of Tracer Experiments in Fissured Aquifers.- Freiburger Schriften zur Hydrologie, Band 2, 107 S., Freiburg (Germany).

MALOSZEWSKI P, HARUM, T., BENISCHKE, R. (1992): Mathematical Modelling of Tracer Experiments in the Karst of Lurbach System in BEHRENS, H., BENISCHKE, R., BRICELJ, M., HARUM, T., KÄSS, W., KOSI, G., LEDITZKY, H.P., LEIBUNDGUT, CH., MALOSZEWSKI, P., MAURIN, V.,

RAJNER, V., RANK, D., REICHERT, B., STADLER, H., STICHLER, W., TRIMBORN, P., ZOJER, H., ZUPAN, M. (1992): Investigations with Natural and Artificial Tracers in the Karst Aquifer of the Lurbach System (Peggau-Tanneben-Semriach, Austria) in Steir. Beitr. Z. Hydrogeologie, 43, S. 116-143, Graz (Austria).

MALOSZEWSKI, P.; BENISCHKE, R.; HARUM, T. & H. ZOJER (1994): Estimation of. Solute Transport Parameters in Heterogeneous Groundwater Systems of a Karstic Aquifer Using Artificial Tracer Experiments. - Water Down Unter'94, Vol.2 Part A, 105-111; Adelaide (Australia).

WERNER, A.; HÖTZL, H.; KÄSS, W. & P. MALOSZEWSKI (1997A): Interpretation of tracer experiments in the Danube-Aach-System with analytical models.- Proceedings of the 5th Symposium on Karst Waters&Environmental Impacts 1995, 153-160, Rotterdam (The Netherlands).

WERNER, A., HÖTZL, H. & MALOSZEWSKI, P. (1997B): Interpretation of Tracer Tests in Karst Systems with unsteady flow conditions. IAHS-Workshop W2: Karst Hydrology, Rabat (Marocco). (in preparation)

WERNER, A. (1997): Auswertung von künstlichen Markierungsversuchen zur Quantifizierung der Abflußdynamik in Karstsystemen, Schrift. Angewandte Geologie, Band 51, Karlsruhe (Germany). (in preparation)

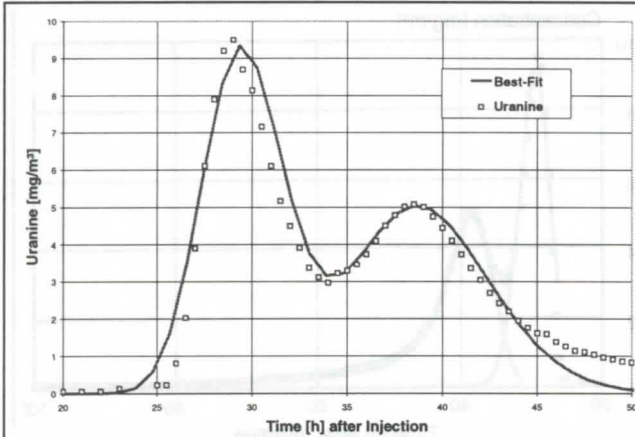

Analytical Model (steady flow)

	PEAK I	PEAK II
Mean transit time [h]:	29.7	39.2
Dispersivity [m]:	31.3	49.2

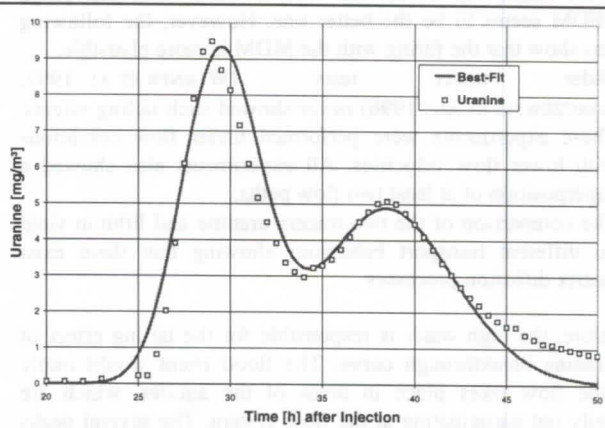

Numerical Model (steady flow) with analytical values

	PEAK I	PEAK II
Mean transit time [h]:	29.7	39.2
Dispersivity [m]:	31.3	49.2

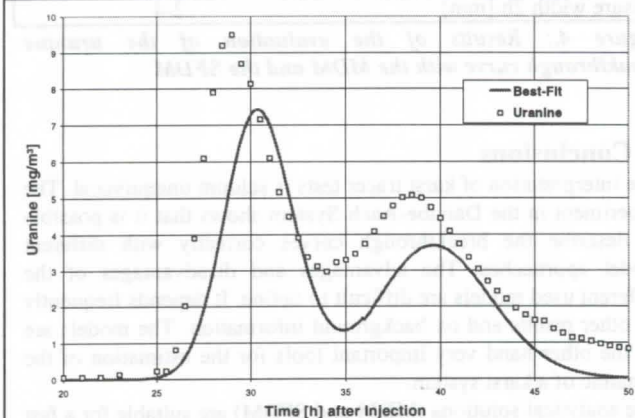

Numerical Model (unsteady flow) with analytical values

	PEAK I	PEAK II
Mean transit time [h]:	29.7	39.2
Dispersivity [m]:	31.3	49.2

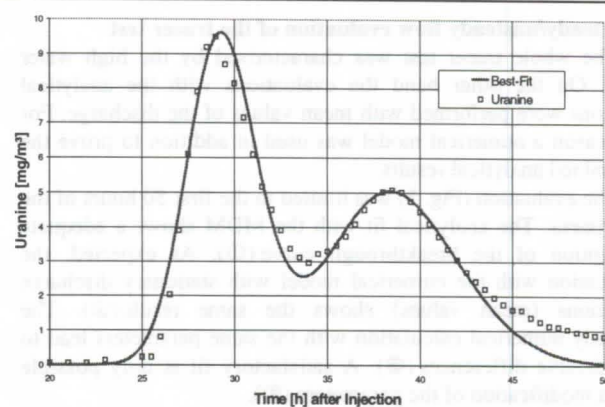

Numerical Model (unsteady flow)

	PEAK I	PEAK II
Mean transit time [h]:	28.5	35.4
Dispersivity [m]:	36	71

Figure 5: Comparison of the evaluation with steady and unsteady flow conditions

Storm pulses, thresholds, and fluid mechanics in the transport of clastic sediments in limestone aquifers

by William B. White & Elizabeth L. White

Department of Geosciences and Environmental Resources Research Institute
The Pennsylvania State University, University Park, PA 16802 USA

Abstract

Active conduit systems carry a flux of water from recharge regions to discharge downstream at karst springs. They also carry a flux of clastic sediments. Transport of clastic sediments is episodic. Sediment piles are moved mainly during extreme floods. Relationships between sediment particle sizes and stream flow can be used to determine paleoflow characteristics of caves passages from the clastic sediments and also to calculate the magnitude of flood pulses needed to maintain the sediment flux.

1. Introduction

All caves that are part of active karst drainage systems contain and transport a certain flux of clastic sediment. These are seen in the caves as deposits of clays, sands, silts and occasional cobbles and boulders. These are usually derived from sandstones and other rocks that have been transported into the cave system from non-local sources. It was demonstrated long ago (WHITE & WHITE (1968) that any karstic drainage basin with a component of allogenic recharge must carry a sediment load. Tributary surface streams remove weathered rock material and carry it into the underground system at their swallets. If the transport processes for transporting the clastic material are not sufficient to handle the load being injected into the system by sinking streams, the subterranean drainage system would simply clog up. The underground drainage would then be forced to return to surface routes. However, it is apparent that the transport of these sediments is not continuous. The transport is episodic related to extreme storm events that inject very large quantities of water into the karstic system. The sediments move through the karst system as a series of pulses rather than as a continuous flow. Furthermore there should exist a threshold in the conduit flow velocity, below which the sediment will not move. Under sub-threshold conditions, the sediments will simply pile up in the conduit system. Only when the threshold is exceeded will a pulse of clastic material be flushed through and out of the conduit system.

Our purpose in the present paper is to establish some criteria for sediment movement, for the thresholds, and some analysis of the episodic nature of sediment movement in terms of the repeat frequency of severe storms.

2. Clastic Sediments in Karst Aquifers

Clastic sediments consist of interbedded clays, silts, sands, gravels, cobbles and boulders with widely varying distributions of particle sizes and widely varying degrees of sorting. At any particular location in a cave, the clastic sediments often exhibit a distinct sequence of beds (Fig. 1-A). However, these bed sequences can seldom be traced for any great

distance along cave passages. Some beds are well sorted, containing a relatively narrow distribution of particle sizes; others are chaotic with sediment particles of sizes from clay to boulders intermixed. A stratigraphic section can be constructed at any particular point along a cave passages, but these sections are not very useful for the interpretation of depositional processes.

In order to discuss the relation of clastic sediment deposits to the stream flow processes that transport them, it is useful to classify the deposits into facies. These are:

- Slackwater facies
- Channel facies
- Stormwater facies
- Extreme flood facies

The typical appearance of these facies for some common sedimentary sequences from the low relief caves of eastern United States are illustrated schematically in Fig. 1.

The channel facies represents sorted or partially sorted sediments that have been moved or deposited along the cave passage. Figure 1-A shows a filled side passage off Rose's Pass in Mammoth Cave (DAVIES & CHAO, 1959). The passage is filled with bedded sands and gravels which result from various flow conditions at a time when the passage was an active streamway. These sediments were transported mainly as bedload.

At the top of the section in Fig. 1-A is a layer of laminated clay which is called a slackwater facies. When passage are plugged with sediment or blocked by breakdown, they can still be flooded with muddy water when base levels rise. In many caves, the final sediment to be deposited is a layer of laminated clay transported as suspended load in the backed-up floodwaters.

In some caves, active streams have cut through the channel facies to form a secondary stream channel with bed material consisting of gravel, cobbles and boulders (Fig. 1-B). This coarse grained

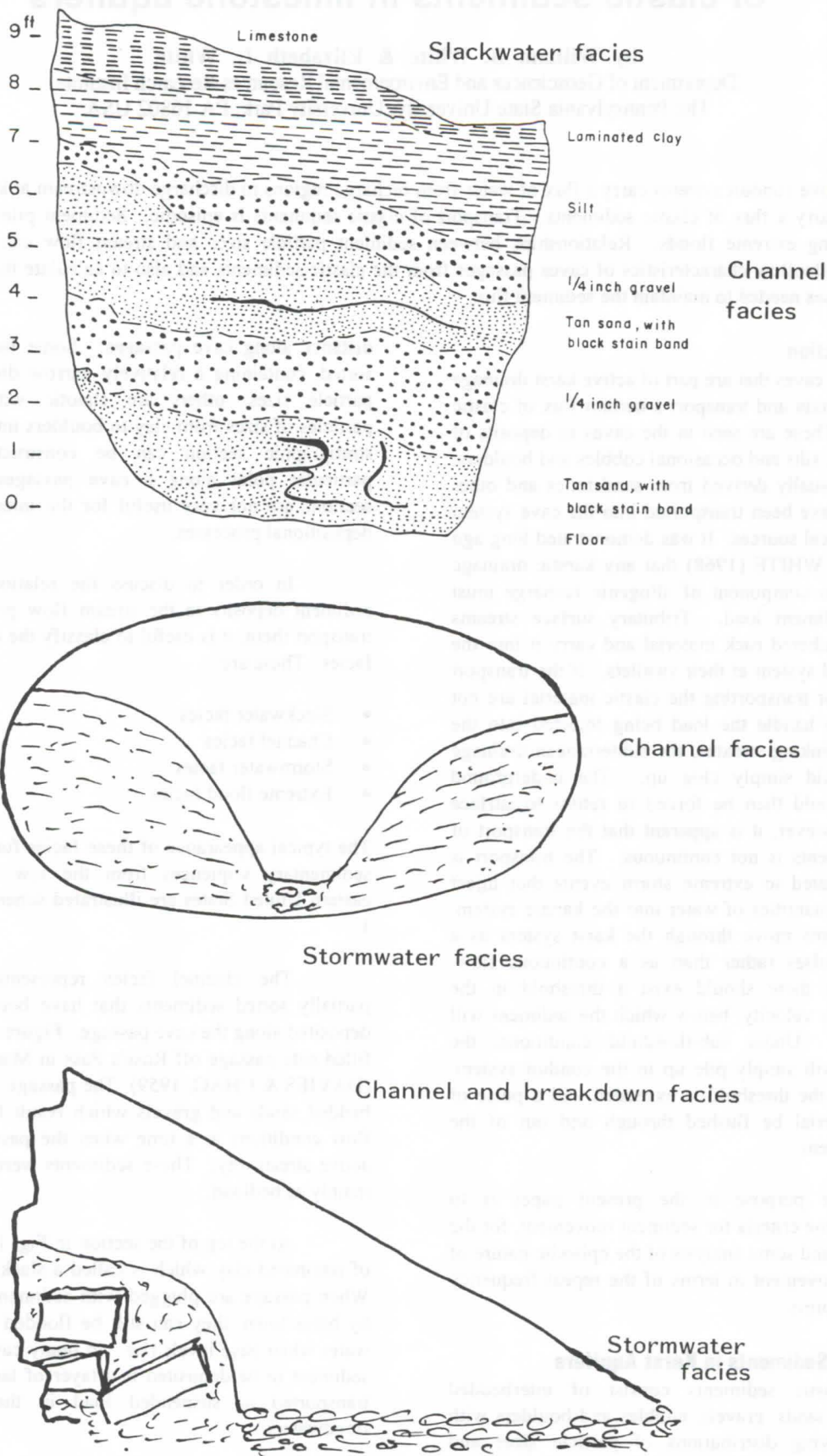

Figure 1. Sketches showing clastic sediment facies: (A) Mammoth Cave (from DAVIES & CHAO, 1959), (B) Generic channel form, (C) Tytoona Cave, Pennsylvania, USA

material from which all of the sand and clay has been winnowed out is called a stormwater facies. Figure 1-C shows a sketch of Tytoona Cave in central Pennsylvania, an active streamway, in which the stormwater facies occupies most of the passage with only some remnant banks of the channel facies.

Not shown in the sketches are unsorted sediments consisting of a chaotic mixture of all particle sizes from clay to boulders. The Butler Cave - Sinking Creek System, Virginia, USA contains large inflows of these chaotic deposits (WHITE & HESS, 1982). Absence of sorting can be ascribed to sediment transport by extreme floods which entrain the entire sediment pile and move it along the cave passage. The Butler Cave passages which contain the extreme flood facies are on the flank of a syncline and have much steeper channel slopes than other caves examined.

The facies described above are arranged in order of increasing stream power required for their transport. The slackwater facies are transported and deposited as suspended load. Rising water levels during floods can back-flood into all parts of the cave and which allows the slackwater clays to settle without the necessity of high flow velocities and with very little required stream power. The channel facies sediments are moved mainly as bedload during flood events of moderate intensity. Once the flow systems that deposited them have been reduced, either by loss of recharge or by diversion of streamflows into other routes the channel deposits tend to remain as part of the sedimentary record. The stormwater facies are those sediments that require flood events to be transported as bedload. Normal flows and floods of moderate intensity serve to winnow clay and sand sized particles, leaving only the cobble and boulder size material as a form of bed armoring. Extreme flood facies are found in caves with steep gradients and which are otherwise subject to catastrophic flooding.

3. Mechanisms and Thresholds for Sediment Transport

There is a large literature on sediment transport written mainly by civil engineers (GRAF, 1971; VANONI, 1975). The mechanisms and thresholds for sediment transport have been determined by laboratory experiments using flumes with uniform particle size beds (homogeneous beds). The critical shear stress for movement of bedload provides a threshold below which the sediment does not move. Many experiments establish the relationship of critical shear stress to particle size (VANONI, 1975). A fitted equation is

$$\tau_c = 0.067 D_{50}^{1.08}$$

where τ_c is the critical shear stress in kg/m^2 and D_{50} is the median particle size in mm.

The critical boundary shear is determined by flow depth, d , and channel slope, S .

$$\tau = \gamma d S$$

where γ is the specific weight of water. These parameters are also connected to the stream power

$$\Omega = \gamma w d \bar{V} S = \gamma Q S$$

where w is the channel width, \bar{V} is the mean flow velocity (m/sec), Q is the volume discharge (m^3/sec), and Ω is the stream power in watts (Joule-sec).

Transferring concepts developed for surface streams with continuous slopes to conduit systems with irregular slopes and alternating reaches of open channel flow and closed conduit flow requires replacing channel slopes with overall hydraulic gradients. Some hydraulic significance can be attached to the facies concepts introduced in this paper. For any sediment transfer, the threshold for bed movement must be exceeded. The channel facies require flow volumes and flow velocities expected from annual high flows and from moderate floods. Stormwater facies require high floods to provide the necessary stream power to move the cobble and boulder beds. Moderate flows of more frequent recurrence serve to extract silt and sand size particles leaving only the very coarse part of the bedload to await in infrequent high floods.

A second threshold must be exceeded to achieve complete entrainment of the clastic sediment deposits. The entrainment threshold is exceeded only during extreme floods (50 - 100 year recurrence interval, typically) and results in the extreme flood facies, consisting of unsorted sediments with a wide range of particle sizes.

4. Conclusions

Clastic sediments in caves can be classified according to the flow regimes required to transport them. Examination of the flow velocities and stream powers required to transport clastic sediments suggests that flood events of various magnitudes provide the power source necessary to transport the flux of clastic sediments through karst aquifers.

References

- DAVIES, W.E. & E.C.T. CHAO. 1959. Report on the sediments of Mammoth Cave, Kentucky. Administrative Report, U.S. Geol. Survey to Natl. Park Service, 117 pp.
- GRAF, W.H. 1971. *Hydraulics of Sediment Transport*, McGraw-Hill, New York, 513 pp.
- VANONI, V.A. 1975. *Sedimentation Engineering*. Amer. Soc. Civil Eng., New York, 745 pp.
- WHITE, E.L. & W.B. WHITE. 1968. Dynamics of sediment transport in limestone caves. *Natl. Speleol. Soc. Bull.* 30: 115-129.

... of the ... of the ...

... of the ... of the ...

... of the ... of the ...

... of the ... of the ...

4. Conclusions

... of the ... of the ...

References

... of the ... of the ...

... of the ... of the ...

... of the ... of the ...

... of the ... of the ...

1. Introduction and Objectives for Sediment

... of the ... of the ...

$$D_{50} = 0.067 D_{10}^{1.5}$$

... of the ... of the ...

Borehole tests for megascale channeling in carbonate aquifers

by Stephen R.H. Worthington and Derek C. Ford

Department of Geography, McMaster University, Hamilton, Ontario, L8S 4K1, Canada.

Abstract

Dissolution processes in carbonate aquifers commonly result in an interconnected network of enlarged fractures, or channels, which make up only a very small fraction of the rock volume. This means that averages from hydraulic testing represent the relatively slow flow through the matrix and tectonic fractures, and give little information on channeling.

We have analyzed hydraulic conductivity, water level and water quality data from dolomite terranes in Ontario (Canada) and limestone terranes in Kentucky (USA) with known networks of channels. Seven test methods in particular have been found useful in indicating the presence of extensive channels. The combination of several of the above seven methods is an excellent way of detecting whether an aquifer has an extensive network of interconnected channels with rapid solute transport.

1. Introduction

Two conceptual models of flow in carbonate aquifers have been developed over the last hundred years. One model considers that solution is not normally of major importance in enhancing the permeability of carbonates, so that carbonate aquifers may be studied in the same way as other bedrock aquifers. Thus the fracture networks are tectonic in nature, cavities encountered in drilling are "vugs" rather than laterally persistent channels, and flow may be studied by equivalent porous medium (EPM) models. This view is implicitly followed in general hydrogeology texts such as FREEZE & CHERRY (1979).

The second conceptual model of flow in carbonate aquifers stresses that solution is commonly of considerable importance in enhancing the permeability of carbonate rocks. The landscapes over such aquifers are often so distinctive that they are termed karst landscapes. This model is followed in specialist texts on carbonate hydrogeology such as WHITE (1988) and FORD & WILLIAMS (1989).

The differences between the two models are fundamental, and of considerable significance to the movement of contaminants. The two models represent end members of a spectrum. There has been some discussion in the literature of this spectrum (e.g. WHITE, 1969), but there are no practical tests using borehole data that are currently in widespread use to differentiate where on the spectrum a given field site lies. Given the considerable differences between the end members of the spectrum, there is a need for explicit borehole tests. Seven possible tests are outlined below.

2. Terminology: channels, conduits, macrofissures and karst

Confusing and contradictory terminology is a major barrier to communication of ideas on flow in carbonate aquifers. Meteoric water circulating through an unconfined carbonate aquifer will tend to produce an integrated network of solutionally-enlarged fractures. These enlarged fractures have been called channels (CHOQUETTE & PRAY, 1970), macrofissures (REEVES, 1979), or secondary fissures (PRICE *et al.*, 1993), and larger examples are known as conduits (> 1cm diameter) or caves (~ >1m, enterable by people) (WHITE, 1988; FORD & WILLIAMS, 1989). The interconnectivity of the enlarged fractures is of prime importance, and this is emphasised in the term megascale channeling (WINOGRAD & PEARSON, 1976). This latter term will be used in the following account to describe interconnected solutionally-enlarged fractures, which may range in aperture from less than 1mm to more than 10m, and in lateral extent up to tens of

kilometres (WINOGRAD & PEARSON, 1976; QUINLAN & EWERS, 1989).

The term karst is generally understood to describe a landscape which is distinctive because it is underlain by soluble rocks. Aquifers in the soluble rocks underlying karst topography are often called karst aquifers or karstic aquifers. To many hydrogeologists caves are an essential component of a karst aquifer. Thus a karst aquifer can be thought of as an extreme example of an aquifer with megascale channeling.

3. Seven test methods that may indicate interconnected channels

An important characteristic of carbonate aquifers with networks of solutionally-enlarged fractures is that these networks can function effectively at transporting solutes rapidly yet only occupy a very small fraction of aquifer volume. For instance, for the limestone aquifer in the Mendip Hills (England), ATKINSON (1977) calculated that the interconnected conduit network accounted for only 0.03% of the aquifer volume. Consequently, boreholes are unlikely to intersect the major arteries of the network. Instead, tests should be designed to sample for the existence of the network of interconnected channels. One proven method and six potentially useful methods are described below.

i) Well-to-well or well-to-spring tracer tests

Tracer testing is a well-proven method of measuring flow direction and velocity in carbonate aquifers (FORD & WILLIAMS, 1989, pp. 219-241). The technique is more than 100 years old, and more than 10,000 successful tests have been conducted. Most tests have been under natural gradient conditions from sinking streams to springs, with boreholes used in a smaller number of tests. Fluorescent dyes are the most popular tracers, combining low cost and low toxicity with high detectability.

An example of a well to spring test in Ontario is shown in Figure 1. The orange dye Rhodamine WT was used, with 19mg of dye being injected at a well. The dye was recovered at a spring 120m away, demonstrating a solute velocity of 6.2×10^{-3} m/s. This measured velocity is some thousand times faster than velocities calculated using hydraulic conductivity measurements and EPM assumptions.

Natural gradient well to well tests are not assured of success since the main channel network may not be intersected by the well. Therefore moderate pumping is recommended to draw the tracer to the monitoring well.

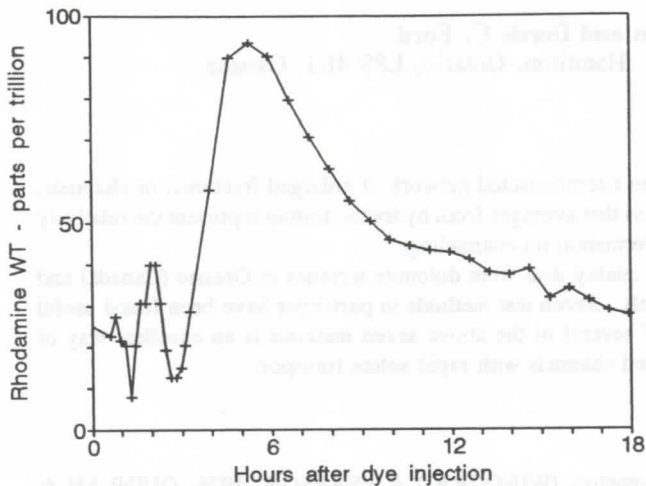

Figure 1. Breakthrough curve of a Rhodamine WT tracer test in dolomite from a borehole to a spring. Typical features shown are the rapid rise and exponential recession, and high sensitivity of the technique.

ii) Combination of core, packer, slug and pump tests

In an ideal porous medium, permeability is independent of the test scale. Thus the permeability calculated from core and pumping tests should be similar. This will not be true in many fractured media, and is especially untrue where there is extensive solution. In such cases, core tests and packer tests across unfractured intervals only measure matrix permeability. Packer tests across fractured intervals and slug tests will give higher values as they include both the matrix and some fracture permeability. Pump tests will give yet higher values as they will also sample the channel network. Thus the permeability increases with the scale of a test (QUINLAN *et al.*, 1992).

Some examples of permeability tests in Paleozoic carbonates are shown in Figure 2. All five sites are broadly similar in packer or slug permeability, but other hydraulic tests give considerably different results.

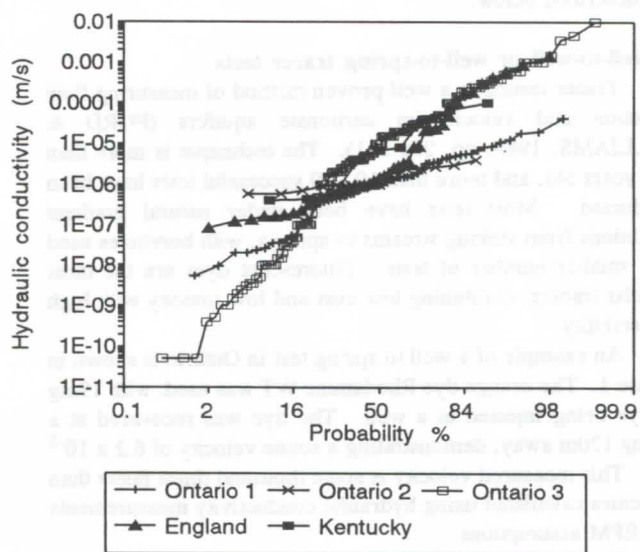

Figure 2. Log-normal hydraulic conductivity tests in Paleozoic carbonates using packers (Ontario) and slug tests (England, Kentucky).

In the central Kentucky limestones core tests have given hydraulic conductivity values of 10^{-11} m/s (BROWN & LAMBERT, 1963), but slug tests give values a million times higher (Figure 2). A similar range of values is found in the Ordovician dolomites in Ontario, from consultants reports at sites along the Niagara Escarpment. Packer tests across unfractured intervals give values of 10^{-11} to 10^{-8} m/s, while pump tests and packer tests across open fractures commonly give values of 10^{-5} to 10^{-3} m/s.

The site in Kentucky is in the Mississippian limestones of the Turnhole Spring catchment. Turnhole Spring lies within Mammoth Cave National Park, and Mammoth Cave is the most extensive cave in the world. Most of the borehole tests shown in Figure 2 were made within 50m of a megascale channel, which has been shown by tracer testing and flow measurement to be at least 18km long and to have an aperture of at least several metres (QUINLAN & EWERS, 1989). Primary porosity of the limestone is 3.3% (BROWN & LAMBERT, 1963).

The site in England is the Mendip Hills, a Mississippian limestone aquifer with 0.8% effective porosity, but with extensive surface karst features and caves (ATKINSON, 1977). The slug tests were undertaken in a quarry to which several tracer tests were made. The tests showed velocities of 0.001-0.003 m/s, indicating megascale channeling (EDWARDS *et al.*, 1992).

The three sites in Ontario in Figure 2 are in low porosity (<5%) Ordovician dolomites. Glaciation as recently as 13,000 years ago has removed or infilled most surficial karst features. However, megascale channelling in the dolomite aquifer has been demonstrated by tracer tests (Figure 1).

iii) Variable rate pumping test

HICKEY (1984) showed that the pumping rate should be proportional to the drawdown in observation wells if Darcy's Law is valid within the cone of depression. In the carbonate aquifer in Florida this was found to be true for one series of tests. It has yet to be shown whether how sensitive this technique is for detecting departures from Darcy's Law in the vicinity of channel networks with turbulent flow.

iv) Matrix and fracture packer test to calculate fracture extent

PRICE (1994) described a method for estimating the extent of interconnected fractures intersected by wells by using steady-state packer testing. The contrast between the permeability of the matrix and of a fracture isolated by packers can be used to estimate fissure extent. The method uses some simplifying assumptions (e.g. homogeneous, isotropic matrix, parallel plate constant aperture fissures), but is useful for differentiating whether an open fracture intersected by drilling is an isolated vug or is connected to an extensive interconnected channel network.

v) Symmetry of cones of depression at pumping wells

The cone of depression at a pumping well is symmetrical in a homogeneous porous medium. However, the cone of depression is likely to be irregular if there is extensive channeling nearby. Figure 3 shows an example from a pumping test in Ordovician dolomite in Ontario. Most of the observation well water levels do not closely correspond to the idealised cone of depression, and between two of these wells (87-4B and W1-B) the hydraulic gradient is away from the pumping well. However, the most interesting feature is the cascading of water into the well from a single fracture. Most of the pumped water

came from this single fracture, indicating an extensive interconnected channel network.

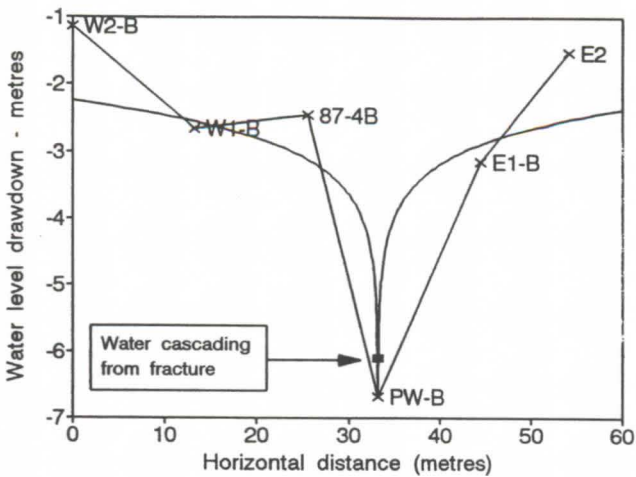

Figure 3. Water level profiles during a pumping test in dolomite in Ontario. The curved lines represent the best-fit cone of depression from all nine observation wells.

vi) Continuous water level monitoring

Interconnected channel networks transmit water quickly, so a prompt water level response in boreholes can be expected following rainfall. Such a response will not be detected by conventional weekly or monthly water level measurement programmes. Continuous water level monitoring is technically straightforward, and the response magnitude and lag following precipitation is valuable for indicating channel connectivity. In Central Kentucky water levels in well often rise by several metres within hours of major rainfall events (QUINLAN & EWERS, 1989).

vii) Frequent water quality monitoring

Precipitation which rapidly infiltrates along channel networks commonly has a much lower solute concentration than long-residence matrix water. Thus variation in solute concentration at a well should be an indicator of connectivity to major channel networks. Frequent sampling is necessary to detect the rapid response following rainfall. QUINLAN *et al.* (1982) have shown how a sampling interval of hours rather than days may be necessary for an adequate understanding of solute changes following rainfall.

Figure 4 shows trichlorobenzene concentrations in a bedrock well at a contaminated site on Ontario dolomites. Daily measurements here reveal increasing concentrations during a runoff recession (November 1 - 24) and a hundredfold decrease following precipitation (November 27 - December 4th). The lag here between precipitation and dilution at the well is about three days. Traditional infrequent sampling such as quarterly would completely miss such short-term variability in solute concentrations.

4. Discussion

Tracer testing is the only one of the seven techniques that is likely to give simple, unequivocal evidence that megascale channeling is present. This is because the groundwater velocities measured in carbonates are usually in the range 0.002 - 0.2 m/s. Such velocities are orders of magnitude more rapid than

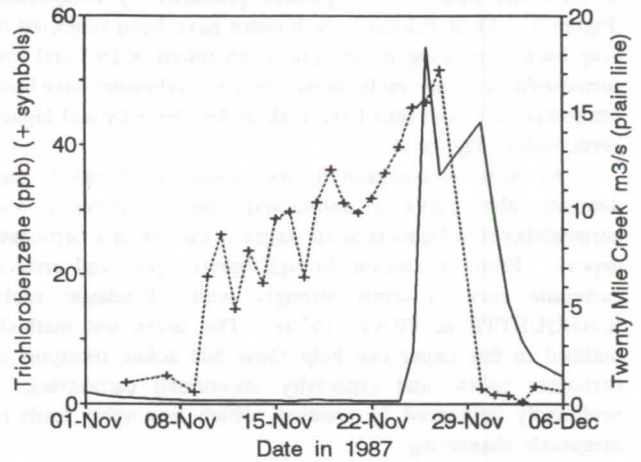

Figure 4. Rapid changes in trichlorobenzene concentrations in a dolomite aquifer in Ontario, showing lagged inverse correlation to runoff.

predictions based on Darcy's Law, and can only be explained by megascale channeling.

The remaining six techniques make use of, or are extensions of commonly collected data from boreholes. Each of them can be used to investigate the possibility of megascale channeling; together the evidence from several of these techniques may give strong evidence for megascale channeling.

Major karst hydrological features such as sinking streams, caves containing streams, and large springs definitively show that megascale channeling is present. However, there is no simple test that will show that megascale channeling is not present.

Some authors have suggested that limestones and dolomites have higher permeability and porosity values if they are karstic (e.g. (FREEZE & CHERRY, 1979, pp. 26, 37). However, the permeability enhancement is likely to be minor, especially if tested by low aquifer volume core, packer or slug tests. Furthermore, porosity enhancement due to megascale channeling is negligible; even for the well-karstified aquifer in the Mendip Hills, England, where extensive caves have been found, the porosity enhancement by channeling is only 0.03% (ATKINSON, 1977).

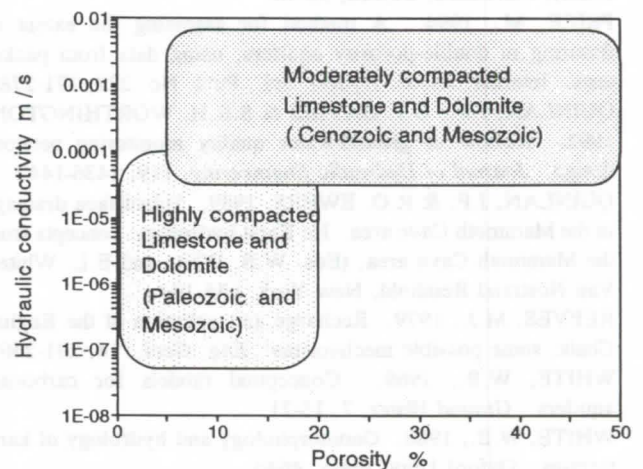

Figure 5. General range of hydraulic conductivity and porosity in unconfined carbonate aquifers, as a function of compaction and age.

Instead, the substantial range in permeability and porosity in carbonate aquifers is explained primarily by compaction (Figure 5). Most Paleozoic carbonates have been subjected to deep burial, resulting in low porosities (often <2%) and low permeabilities. Conversely, most Cenozoic carbonates have been compacted less, and thus have both higher porosity and higher permeability (Figure 5).

As well as compaction, the solubility of calcite and dolomite also plays a substantial role in porosity and permeability development at all stages in the life of a carbonate deposit. From deposition through burial, uplift and erosion carbonate rocks contrast strongly with siliciclastic rocks (CHOQUETTE & PRAY, 1970). The seven test methods outlined in this paper can help show that solute transport in carbonate rocks, and especially unconfined carbonates, is profoundly influenced by solution, which inexorably leads to megascale channeling.

References

- ATKINSON, T.C., 1977. Diffuse flow and conduit flow in limestone terrain in the Mendip Hills, Somerset (Great Britain). *J. Hydrol.*, 35, 93-110.
- BROWN, R.F., & T.W. LAMBERT, 1963. Reconnaissance of ground water resources in the Mississippian Plateau region, Kentucky, U.S. Geol. Survey Water-Supply Paper 1837, 64p.
- CHOQUETTE, P.W., & L.C. PRAY, 1970. Geological nomenclature and classification of porosity in sedimentary carbonates. *Am. Assoc. Petrol. Geologists Bull.*, 54, 207-250.
- EDWARDS, A.J., S.L. HOBBS & P.L. SMART, 1992. Effects of quarry dewatering on a karstified limestone aquifer; a case study from the Mendip Hills, England. Proc. Third Conference on Hydrogeology, Ecology, Monitoring, and Management of Ground Water in Karst Terranes, National Ground Water Association, Dublin, Ohio.
- FORD, D.C. & P. WILLIAMS, 1989. Karst geomorphology and hydrology. Unwin Hyman, London, 601p.
- FREEZE, R.A. & J.A. CHERRY, 1979. Groundwater. Prentice-Hall, Englewood Cliffs, NJ, 604p.
- HICKEY, J.J., 1984. Field testing the hypothesis of Darcian flow through a carbonate aquifer. *Ground Water*, 22, 544-547.
- PRICE, M., R.A. DOWNING & W.M. EDMUNDS, 1993. The Chalk as an aquifer. In: *The Hydrogeology of the Chalk of North-West Europe* (Eds. R.A. Downing, M. Price and G.P. Jones), Clarendon, Oxford, 35-58.
- PRICE, M., 1994. A method for assessing the extent of fissuring in double-porosity aquifers, using data from packer tests. *Internat. Assoc. Hydrol. Sci.*, Publ. No. 222, 271-278.
- QUINLAN, J.F., G.J. DAVIES & S.R.H. WORTHINGTON, 1992. Review of ground-water quality monitoring network design. *Journal of Hydraulic Engineering*, 119, 1436-1442.
- QUINLAN, J.F. & R.O. EWERS, 1989. Subsurface drainage in the Mammoth Cave area. In: *Karst hydrology: concepts from the Mammoth Cave area*, (Eds. W.B. White and E.L. White), Van Nostrand Reinhold, New York, p65-103.
- REEVES, M.J., 1979. Recharge and pollution of the English Chalk: some possible mechanisms. *Eng. Geol.*, 14, 231-240.
- WHITE, W.B., 1969. Conceptual models for carbonate aquifers. *Ground Water*, 7, 15-21.
- WHITE, W.B., 1988. *Geomorphology and hydrology of karst terrains*. Oxford Univ. Press, 464p.
- WINOGRAD, I.J., & F.J. PEARSON, 1976. Major Carbon 14 anomaly in a regional carbonate aquifer: possible evidence for megascale channeling, South Central Great Basin. *Water Resources Research*, 12, 1125-1143.

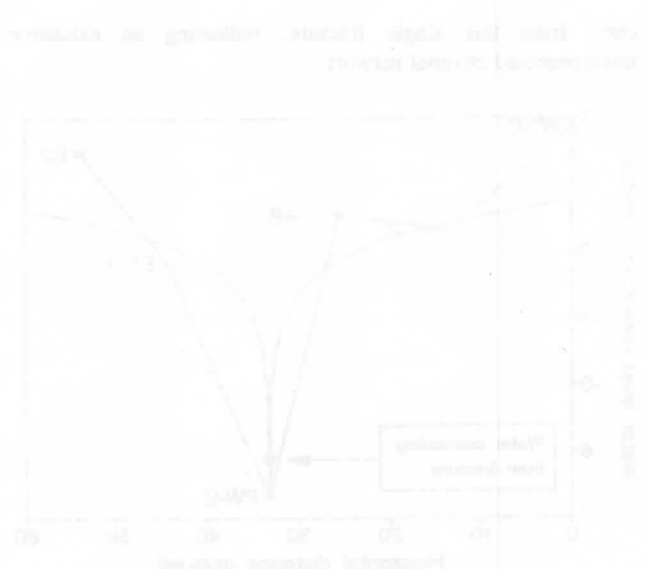

Estimation of aquifer parameters in highly permeable limestone (Biscayne Aquifer, Florida)

Eric Zechner, David Genereux, Jose D.A. Guardiola, James E. Saiers
Geology Department, Florida International University, Miami, FL 33199, USA

Hydrogeological Setting

The surficial Biscayne Aquifer (BA) extends from the Atlantic Coast of SE-Florida about 50-80 km westward into the Everglades. It is the source of most water supplies in this densely populated region and is considered one of the most permeable in the world. The extensive use of the BA with canal systems and large-scale pumping as a result of urban development leads to problems such as coastal saltwater intrusion, groundwater pollution, and drainage of the sensitive ecosystem of the Everglades marshes. In the studied field site at the eastern border of Everglades National Park, 50 km SW of Miami, the BA reaches a thickness of nearly 15 m. It consists of coralline, bryozoan, shelly, and in some parts sandy limestone of Pleistocene age. Groundwater flow is enhanced due to a strongly developed secondary porosity with frequent solution cavities. In zones of abundant solution holes hydraulic conductivity exceeds 10^{-1} m/s. The two formations making up the BA, the Miami Limestone and the underlying Ft. Thompson Formation are separated with a 0.3 m thick condensed micritic and less porous layer.

Parameter Estimation

Groundwater models have become a widely used and important tool to estimate the relevant hydraulic parameters. The accuracy of models are strongly related to the density of available data which are used in the parameter estimation procedure. The most common approach is still trial-and-error calibration on groundwater head observations. Inverse models may result in a more objective estimation of the relevant hydrogeologic parameters. However, sparse distribution of same type of data often result in insensitive parameters and several models with a different pattern of hydrogeologic parameters may reproduce the dataset equally well. This insensitivity can be reduced using additional field data like (1) direct measurements of the relevant hydraulic parameters with for example aquifer tests, (2) flow at stream boundaries, (3) geological and/or geophysical data, (4) and tracer concentrations.

In the BA groundwater flow is strongly controlled through the manipulation of the canal levels. The relevant hydraulic parameters to be estimated to calculate the aquifer-canal water flow exchange are aquifer hydraulic conductivity, specific yield, and the canal bed conductance. Field measurements of hydraulic parameters have to be adapted to the highly permeable limestone. Pump tests for example would face considerable logistical problems with the use of very large pumps in an area of difficult access (Everglades) and the remote disposal of the water to avoid violating the assumptions required for the analysis. The alternative used was to stress the aquifer with a canal drawdown test. On a 2.4 km long N-S section of L31W, a about 17 m wide canal bordering the Everglades National Park, the canal level was lowered within hours of 0.4 m over a period of 10 days. The response of the groundwater head was monitored continuously in 3 E-W sections of totally 20 piezometers. In addition the canal flow was monitored on both ends of the section with acoustic velocity meters. An analytical model assuming 1-dimensional flow estimated an average hydraulic conductivity for the BA of $9 \cdot 10^{-2}$ m/s and a canal bed conductance of $5 \cdot 10^{-4}$ m/s. A numerical 3D forward flow simulation of the drawdown test with these conductivities showed a fairly good agreement of the observed and simulated head (figure). With a currently developed inverse groundwater model the parameter estimation is gradually improved to quantify the canal seepage with data of canal flow measurements and tracer concentrations of chloride in ground- and canalwater.

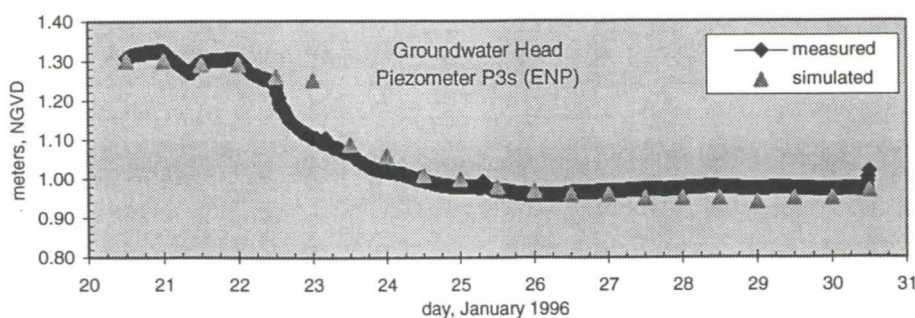

Result of a numerical flow model based only on hydraulic field parameters (no calibration): Measured vs. simulated head of a piezometer in Everglades National Park (ENP), 50m west of canal L31W, during a canal drawdown test in January 1996.

Vulnerability of karstic aquifers in Abruzzi (Italy). Two different case-studies: Gran Sasso mountain and Fucino plain

Ezio Burri, Raniero Massoli-Novelli & Marco Petitta

Dipartimento di Scienze Ambientali, Università degli Studi dell'Aquila, loc. Coppito, 67100 L'Aquila, Italia

Abstract

The Abruzzi Apennine's hydrogeology is characterized by karstic mountain aquifers and main springs located at the massif basal contact.

In the Gran Sasso mountain, infiltration is very high and concentrated in the big glacial-karstic ridges, and is determined by tectonic patterns, climate and numerous karst features. In the 1970's, two highway tunnels intercepted the Gran Sasso regional aquifer and reduced the discharge of surrounding springs. The aquifer vulnerability is very high in infiltration areas (Campo Imperatore plain).

The alluvial-lacustrine sediments that fill the Fucino plain contain an important aquifer, gained from the neighbouring carbonate mountains. Increased agricultural activity causes high pollution risk, increasing deep water exploitation and impoverishment of groundwater resources. This situation has obviously interfered with the hydrogeological setting of the karstic aquifers, determining changes in the dynamic equilibrium of groundwaters.

Riassunto

L'idrogeologia dell'Appennino abruzzese è caratterizzata da estesi acquiferi carbonatici, che alimentano sorgenti basali di portata elevata e regime abbastanza stabile.

Sul Gran Sasso, le sorgenti sono poste a notevole distanza dalle aree di infiltrazione, particolarmente concentrata in depressioni tettono-carsiche; il regime idrodinamico è influenzato da un traforo autostradale, che drena la falda regionale causando ripercussioni sulle sorgenti più vicine. La vulnerabilità risulta particolarmente elevata nelle zone ad infiltrazione concentrata, come Campo Imperatore.

Nella piana del Fucino, i sedimenti quaternari che la colmano sono sede di una importante falda, alimentata direttamente dai rilievi carbonatici circostanti. Il maggiore grado di vulnerabilità si riscontra nella Piana, dove l'intensa attività agricola comporta immissione di inquinanti e depauperamento della falda a causa dei prelievi idrici. L'alterazione dell'equilibrio idrodinamico determina una maggiore vulnerabilità dei vicini acquiferi carsici.

1. Introduction

In the Central Apennine the structural-geological setting was principally conditioned by the Alpine orogeny which formed the carbonate ridges, and at the same time a wide deposition of thick Pliocene and Quaternary sediments in lower areas.

As a result a particular hydrogeological setting has been obtained in which karstic carbonate ridges constitute the most important aquifers and the recent deposits located at the base of the massifs represent their limits of permeability.

The carbonate aquifers are characterized by high permeability due to fractures and to karst and, despite the lithological and structural setting, each ridge can be considered as a single aquifer. The lower permeability of the Plio-quaternary deposits, composed mainly of sands, silts and clays, determines the main base level of the mountain aquifers.

Groundwaters come to the surface through the main springs located at the base of the massifs. Such springs, with high discharge ($> 1 \text{ m}^3/\text{s}$) and a rather steady regime, are limited in number and without the typical features of the mature karstic systems. Moreover the aquifers, inside the carbonate ridges, often interact with the aquifers of the Quaternary deposits, through lateral losses that feed the porous aquifer in the bottom of the valley.

In the carbonate Apennine the infiltration is strongly conditioned by karst on the ridges where numerous and mature karstic phenomena are present: tectonic-karstic depressions, dolina, endoreic basins and sometimes insurgences. Obviously in these areas the infiltration of the rainfall is very high and the runoff can be considered almost zero. Consequently carbonate aquifers are greatly fed by a karstic system.

In the mountain areas of the Apennines, particularly in Abruzzi, a double problem, connected to the vulnerability of the aquifers occurs:

- the pollution risk of the karstic aquifers with high vulnerability in the areas having concentrated infiltration; any possible interferences in the recharge areas or in the unsaturated zone, can have consequences on all the springs of the ridge, because there is no direct karstic connection between the infiltration and the groundwaters emergences;

- the interaction between carbonate aquifers and porous aquifers greatly exploited as drinking water, for irrigation and for industrial supply.

The piezometric variations inside the plains both positive (irrigation) and negative (pumping) determine continuous changes of the hydrodynamic equilibrium, thus affecting the carbonate aquifer.

In this paper we illustrate two different case-studies: the Gran Sasso mountain, one of the greatest regional aquifers and a recently founded National Park, and the Fucino plain, a wide basin with high human interference and with intensive agricultural activity.

2. The Gran Sasso mountain

The Gran Sasso mountain, in Abruzzi, Central Italy, covers an area of about 800 km^2 and has the highest peak at 2.912 m a.s.l. (fig.1). Geological features are a Mesozoic-Tertiary carbonate sequence in marginal or slope facies with a high overthrust toward the north. The tectonic setting is the result of an initial stage, characterized by mainly compressive deformation and a subsequent stage with strong uplift and extensional fault activity (ADAMOLI *et al.*, 1982).

The carbonate aquifer is formed by a series of intercommunicating reservoirs, confined laterally by impermeable outcrops. Infiltration is very high (> 800 mm/year), due to the tectonic patterns, climate and numerous karstic features (polje, karstic basins, etc.), compared with the average rainfall on the massif (approx. 1200 mm/year).

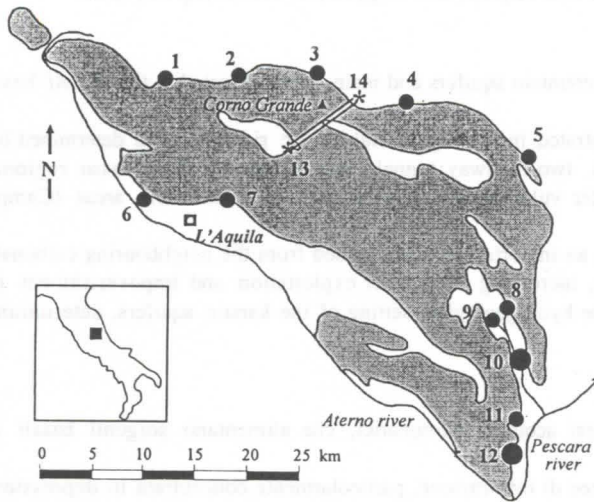

Figure 1 : Area of the Gran Sasso mountain (grey). The main springs (circles), highway tunnels (double line) and their drainage (stars) are shown. The numbers of springs refer to Table 1.

The main springs are located at the massif basal contact with impermeable deposits. There are 12 groups of such springs (tab.1), with a mean discharge of about 27 m³/s: 5 groups are located on the northern side at an elevation of > 1000 m, with a total discharge of about 2 m³/s and substantial seasonal variations; 7 groups, which have a total discharge of about 25 m³/s, are on the southern side at an elevation of < 650 m.

In the 1970's, two highway tunnels, 10.15 km long, were bored in the mountain at an elevation of 900 m. The highway connects Rome with L'Aquila and Teramo, from the Thyrrhenian sea to the Adriatic coast. The highway tunnels have obviously interfered with the hydrogeological setting of the Gran Sasso mountain. Hydrogeological studies were carried out, in particular by A. MONJOIE (1975).

The tunnels intercepted the Gran Sasso regional aquifer, initially on the southern side, with a mean discharge of 0.5 m³/s. Subsequently, the aquifer was also intercepted on the northern side, after about 3 km of boring; in this case, the water seepage quickly exceeded 2 m³/s. When boring ended, between 1980 and 1982, drainage by the tunnels was 1.3 m³/s on the northern side and 0.5 m³/s on the southern side, practically the same as the current values (ADAMOLI, 1990). The immediate consequence of this underground drainage was a marked reduction in the discharge of the springs on the northern side (fig.1, tab.1) that were already being captured almost entirely for drinking water. Because of this, immediate steps were taken to channel the water from the tunnels to the aqueduct network.

Hydrogeological interpretations regarding the variations brought about by the tunnels (MONJOIE, 1975; CELICO, 1983; BONI *et al.* 1986; ADAMOLI, 1990; MASSOLI-NOVELLI & PETITTA, *in press*) indicate that the Gran Sasso aquifer has reacted to the impact of tunnel drainage, in the first place by rapidly changing its hydrodynamic setting (unsteady flow) and discharging large quantities of groundwater. Subsequently, the aquifer adapted to the presence of two new "springs", consisting of the drainage from the tunnels, until it achieved a new

hydrodynamic balance after a few years (steady flow) which corresponds to the present situation.

New monthly monitoring of spring discharge began in 1994, limited to the Vera springs near L'Aquila (PETITTA & MASSOLI-NOVELLI, 1995). Since 1996, this monitoring has been completed with surveys regarding the other main springs on the southern side (Capo Pescara, S. Calisto, Tirino springs) (MASSOLI-NOVELLI & PETITTA *in press*).

Examination of the initial results of the new monitoring of Vera springs produces two main considerations:

- conditions are extremely stable, as proven by the almost constant discharge measured during the year; this stability was not to be found in pre-tunnel values;

- the mean discharge (about 1 m³/s) is considerably less than the discharge measured before and during tunnel construction (1.8 m³/s).

The main characteristic of the Tirino River is that it is fed almost exclusively by groundwater (tab.1, springs n°8-9-10). It receives an average of more than 12 m³/s of water (as much as 18 m³/s in the past) supplied by numerous large groups of springs.

Insufficient data are available at the present time to express meaningful assessments regarding the Tirino springs and the situation there can only be clarified by continuing the monitoring as planned. It has been ascertained, however, that discharge from the Capodacqua Tirino spring has decreased substantially over the past 10-15 years, to the extent that it has been almost halved; this lack of water cannot only be justified by the tunnel drainage, but may also depend on the reduced rainfall.

The on-going monitoring of springs on the southern side of the Gran Sasso provides indispensable data to assess fully the new hydrogeological situation. Only for the Vera springs, for which three years of continuous observations are available, is it possible at the present time to assess the new hydrogeological situation determined by tunnel drainage at a high elevation.

The reduced discharge, which has certainly taken place in basal springs both on the northern and on the southern side (especially Vera), is currently accentuated by the reduced rainfall ascertained in recent years and, therefore, by the reduced recharge of the aquifer. It is not yet possible to establish the extent to which each of the two causes contributes to the current reduced discharge of the main springs.

n°	spring name	elevation n (m a.s.l.)	mean discharge (m ³ /s)
1	Vomano	1300	0,1
2	Chiarino	1320	0,5
3	Rio Arno	1520	0,1
4	Ruzzo	>1000	0,6
5	Vitella d'oro / Mortaio d'Angri	680	0,7
6	Vetoio - Boschetto	630	0,7
7	Vera	650	1,8
8	Capodacqua Tirino	340	5,0
9	Presciano - Il lago	330	2,0
10	Basso Tirino	270	6,0
11	S. Calisto	290	2,1
12	Capo Pescara	250	7,5
13	Tunnels drainage (south)	960	0,5 *
14	Tunnels drainage (north)	890	1,2 *

Table 1 : Gran Sasso: main springs and their discharge in pre-tunnel period. Tunnel discharge (*) refers to current situation.

The drainage from the Gran Sasso highway tunnels (tunnels that were undoubtedly necessary for the region's road system) has definitely determined a new hydrodynamic balance in the karstic carbonate aquifer. However, these changes cannot be considered solely negative, i.e. the decrease in basal spring discharge, because it has to be born in mind that at the present time all the water drained from the tunnels (about 1.7 m³/s) at an elevation of around 1000 m a.s.l. is available for supply as drinking water, and this elevation permits better distribution of the water resources. The reduced discharge observed at the springs, to which a probably transient cycle of low rainfall has definitely contributed, is nevertheless not such as to compromise the ecosystems downstream.

The vulnerability of the Gran Sasso aquifer, because of fracture network and karst features, can be considered very high, particularly in the sectors having concentrated infiltration, of which the most important is Campo Imperatore area. Because there is no direct connection between the basal springs and mature karstic zone, it is possible to suppose a lower vulnerability of these resources than the drained tunnel waters (900 m a.s.l.), probably fed by Campo Imperatore depression (1600 m a.s.l.).

The water drained from the highway tunnels is being captured almost entirely for drinking water and for this reason it is important continuously to protect the environment of the recharge areas. In fact, if the drainage level is higher than the base level of the aquifer, water autopurification can decrease, the water salinity is lower and residence time in the aquifer is shorter. The chemical and physical data collected in these last years are confirming this hypothesis: the drained waters from the tunnels have salinity lower than 0.1 g/l, while the value of the basal springs ranges from 0.15-0.4 g/l.

At present we haven't detailed data to analyse the inflow-outflow diagrams that allow to compute the lag times of the Gran Sasso aquifer in the new hydrodynamic equilibrium.

3. The Fucino plain

The Fucino basin covers an area of about 900 km² on the carbonate mountains of the Apennine chain. From the morphological point of view the basin is characterized by a wide alluvial plain (>200 km²) where in the recent past the largest Apenninic lake has been localized. The oval shaped plain has its greater axis, trending NW-SE, about 19 km long. Heterogeneity Quaternary alluvial-detrital-lacustrine sediments fill the Fucino plain and are over 1000 meters thick.

The Fucino plain and its wide lake didn't originally have a natural outflow. In the past, several reclamations have been carried out to stabilize the level of the lake and then to drain it. The first tunnel was realized by the roman emperor Claudio, in the I^o century A.C.. Drainage canals and tunnels were dug to channel the waters of the Fucino Lake towards the nearby basin of the Liri river. In order to completely drain the lake, Prince A. Torlonia built a second tunnel, which was completed in 1874 and at present it is utilized only in case of need. The drainage work ended in 1942 when one more tunnel, which is still working, was excavated (PETITTA & CAPELLI, 1994).

In the Fucino plain all the springs are fed by the surrounding carbonate ridge (fig.2). A main spring group is located in the south-eastern side of the depression, with a total discharge of 1.2 m³/s. Others natural springs with a total discharge of 0.5 m³/s are in the northern sector. The carbonate ridges also feed an aquifer made up of alluvial gravel-sand deposits (CELICO & CELICO, 1994). By means of drainage canals these groundwaters have been partly channelled in river bed (fig.2), giving important linear springs (>1 m³/s).

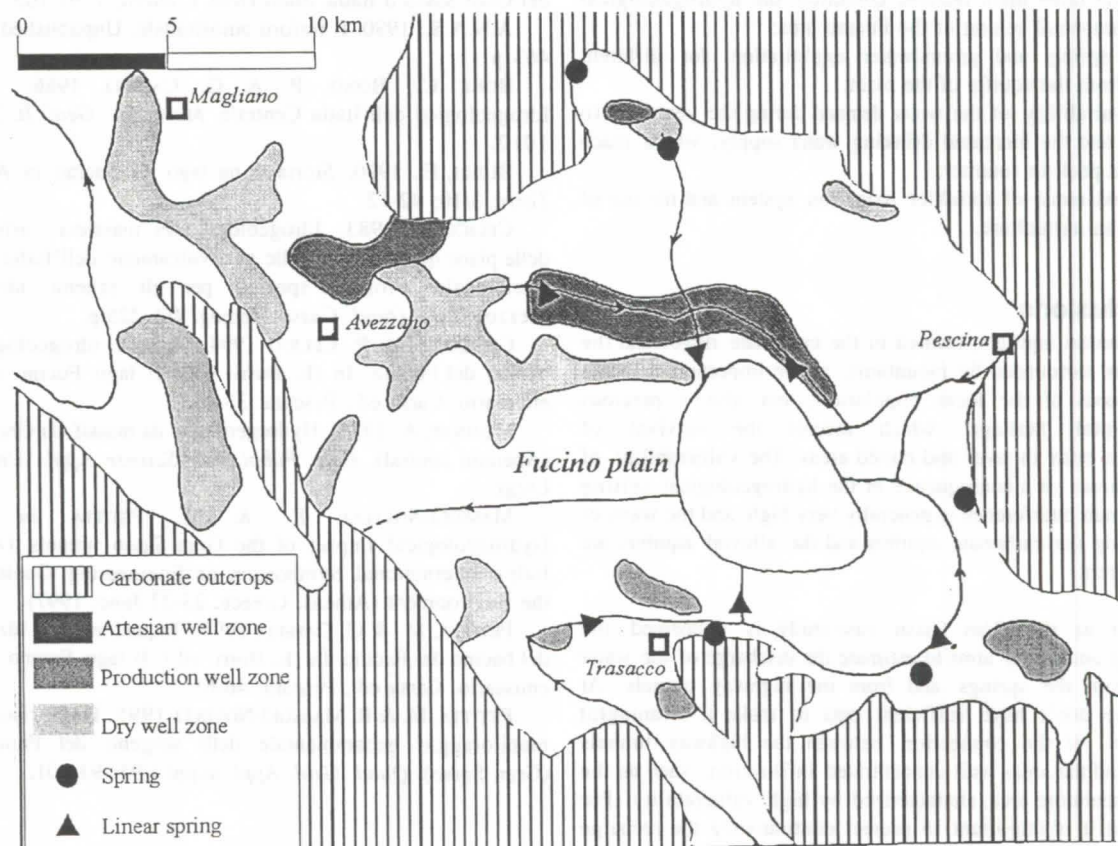

Fig. 2 - Fucino plain: the alluvial-lacustrine deposits (white area) contain a groundwater aquifer, exploited for human activity, mainly for agriculture. Modified from CELICO (1983).

Human interference and drainage have obviously affected the hydrogeological and hydrological setting of the Fucino plain: agricultural activity is modifying the relationship between the carbonate aquifer of the ridge and the alluvial-detrital aquifer of the plain.

In 1874-1875 the Fucino Lake was completely drained, and by means of an underground tunnel 1 billion m³ of water was run into the Liri basin. As a result of this drainage a single vast estate of 14.006 ha, with 210 km of inner roads, 100 km of main canals and 648 km of drainage canals, rose. At present a very specialized agricultural activity is being carried on in this estate (BURRI, 1990) with some growing environmental damages as follows:

- there is a widespread use of pesticides which exceeds 35 kg/ha, well above the Italian national average of 12.8 kg/ha, and above and beyond the general consumption of the Abruzzi Region which is 9.9 kg/ha;

- the system of sprinkler irrigation exceeds the water availability of the canals during the dry season.

In order to solve this problem since the fifties more than 200 wells have been drilled, with a seasonal delivery of about 2.000.000 m³ of water. As a consequence, with a long period of dry weather in the area, there is a remarkable groundwater lowering. In an emergency, 0.1 m³/s are taken from the neighbouring Liri river by means of the tunnel built a century ago.

In the north-western sector of the Fucino plain (fig.2) almost 50% of the wells have proved unproductive (CELICO, 1983); on the contrary, along the south-eastern side, where the main springs are located, the wells are very rich in water. In the plain the groundwater is just a few meters deep and sometimes it is artesian.

However three main features condition the hydrogeological and environmental setting of the Fucino area:

- the spring and groundwater exploitation for different purposes from the aquifer of the plain;

- the variability of the water demand during the year, due to irrigation and the increased drinking water supply, which reach the highest peak in summer;

- the existence of sprinkler irrigation system and the use of pesticides in agriculture.

4. Conclusions

The Abruzzi aquifers, located in the carbonate ridges and the wide plains surrounded by mountains, are an important resource for the needs of the local population, but also a precious environmental heritage, which assures the survival of ecosystems both in river and humid areas. The vulnerability of these resources, as a consequence of the hydrogeological setting and of human interference is generally very high, and the ways of safeguarding the carbonate aquifers and the alluvial aquifers are quite different.

As for as the Gran Sasso case-study is concerned the monitoring under way aims to estimate the discharge of the water drained from the springs and from the highway tunnels. At present we don't have sufficient data to make a meaningful assessment, of the connection between the highway tunnels drainage and the areas with concentrated infiltration, such as the Campo Imperatore area, characterized by high vulnerability. For this reason it is important to protect continuously the recharge areas of the aquifers. It is also important to note that the waters drained from the highway tunnels are utilized as drinking water.

In the case-study of the Fucino plain the alluvial aquifer is highly vulnerable owing to extensive agricultural activity which causes high pollution risks for this shallow carbonate aquifer.

The possible consequences can be summarized as follows:

- reduction of the functionality of the operating wells because of the lowering of the piezometric levels. This kind of problem is already evident and there are reasons to believe that, in some particular situation, it may cause economic and environmental damage, especially if the summer shortage of water gives a precarious hygienic situation in the canal network of the plain. Moreover the pumping and the exploitation of the water are causing the subsidence of the soil, with gas emission.

- reduction of discharge has certainly taken place in normal and linear springs. This phenomenon involves both the lowering of the available supplies of drinking water and the regular downflow in the canals.

- increasing of the vulnerability of the surrounding carbonate aquifers; this problem, not yet sufficiently well studied, could determine infiltration of irrigation waters of poor quality into the karstic aquifers. These phenomena can happen if the saturation level of the carbonate aquifers is lower than the level of plain aquifer, even if this should happen only in some short period of the year.

References

- ADAMOLI, L. 1990. Idrogeologia del massiccio carbonatico del Gran Sasso e conseguenze idrogeologiche degli scavi autostradali. *Geol. Tecn.* 3/90: 4-15.
- ADAMOLI, L.; BERTINI, T.; DEIANA, G.; PIERUCCINI, U. & A. ROMANO 1982. Ricerche geologiche sul Gran Sasso d'Italia (Abruzzo). VI: primi risultati dello studio strutturale della catena del Gran Sasso d'Italia. *Studi Geol. Camerti*, 7: 97-103.
- A.N.A.S., 1980. Il traforo autostradale. Unpublished report, 463 p.
- BONI, C.; BONO, P. & G. CAPELLI 1986. Schema Idrogeologico dell'Italia Centrale. *Mem. Soc. Geol. It.* 36: 991-1012.
- BURRI, E., 1990. Storia di un lago. Il Fucino in Abruzzo. *Terra*, 3/10: 42-52.
- CELICO, P. 1983. Idrogeologia dei massicci carbonatici, delle piane quaternarie e delle aree vulcaniche dell'Italia centro-meridionale: Progetti speciali per gli schemi idrici nel Mezzogiorno. *Quad. Cassa Mezzog.* 4/2, 225 p.
- CELICO, F. & P. CELICO 1994. Aspetti idrogeologici del bacino del Fucino. In (E. Burri, ed.): Il lago Fucino e il suo emissario. Carsa ed., Pescara: 35-45.
- MONJOIE, A. 1975. Hydrogeologie du massif du Gran Sasso (Apennin central). *Coll. Pubbl. Fac. Scienze Appl. Univ.* 53. Liegi.
- MASSOLI-NOVELLI, R. & M. PETITTA *in press*. Hydrogeological impact of the Gran Sasso tunnels (Abruzzi, Italy). International Symposium on Engineering Geology and the Environment (Athens, Greece, 23-27 June, 1997).
- PETITTA, M. & G. CAPELLI 1994. Inquadramento idrologico del bacino del Fucino. In (E. Burri, ed.): Il lago Fucino e il suo emissario. Carsa ed., Pescara: 46-61.
- PETITTA, M. & R. MASSOLI-NOVELLI 1995. Primi risultati del monitoraggio geoambientale delle sorgenti del Fiume Vera (Gran Sasso). *Quad. Geol. Appl. suppl.* 1/95: 93-101.

Thanks to "Consorzio Ricerca Gran Sasso" for their contribution to this research.

Karst hydrogeology and vulnerability in a coastal sector of Nebrodi Mts. region (Northern Sicily)(1)

Antonio Cimino*, Rosario Abbate*, Massimo Macaluso*, Santo Orecchio**

(*) Istituto di Geofisica Mineraria, University of Palermo, Via Mariano Stabile 110, I-90139 Palermo, Italy

(**) Dipartimento di Chimica Inorganica, University of Palermo, Via Archirafi 26, I-90139 Palermo, Italy

Abstract

This paper describes the hydrogeological features of the Acquedolci karst area, in the Western sector of the Nebrodi Park (Sicily), where peculiar geostructural units occur. This region is characterized by the presence of numerous springs, due to the very different permeability units. On the other hand, coastal aquifers represented by sandy-arenaceous formations are supplied by karst limestones; they are undergone to increasing sea-pollution phenomena. The relationships among the hydrogeological units and the anthropic intervention have affected the actual productivity and quality of water resources, principally in the coastal plain. Geochemistry and geophysics have surveyed the main hydrogeological features of the investigated area, most of which are characterized by karst circulation: chemical analyses of groundwaters and apparent resistivity prospecting have evidenced the main aspects affecting the water resources of the region. The results of water geochemistry are presented in form of Langelier-Ludwig and/or Piper diagrams, that show different groups of waters, also depending on the hypogean limestone circulation. Apparent resistivity maps, performed in the coastal sectors, have been traced in order to follow the pollution occurrence and the pattern of the buried formations; the most important of these ones are impervious clayey units and permeable arenaceous units. The final purpose of this research will be the elaboration of the first vulnerability map of the Acquedolci plain.

1. Introduction

This paper deals with the hydrogeology of an area belonging to the north-western sector of the Nebrodi Mountains. It is executed in the ambit of the research program relevant to the study of water resources of Eastern Sicily. The Nebrodi range is mainly characterized by scarcely permeable terrains (figure 1): as a matter of fact, groundwaters are generally deficient or very sparse. So, the water productivity results insufficient to the needs of the population. As a consequence, the study of the karst area of Acquedolci is very interesting because it might represent an appreciable water reservoir for this particular sector of Sicily.

Goal of this paper is to describe - by means of selected methodologies - the geomorphologic and hydrogeological characteristics of this area. The acquired data have allowed us to know more deeply the hydrogeological structures of the examined area and hence propose their better management and protection.

2. Geomorphological outlines

The considered territory, parallel to the coast line (figure 2) is delimited at North by Tyrrhenian Sea and at South by a group of carbonate relieves that sharply rise from the plain. At West the Furiano torrent end to the sea in a wide coastal fan. This torrent presents, as the other ones in the territory, regular courses, with narrow valleys deeply engraved on mount. Along the medium and lower courses, it presents a considerably wide bed, extending also more than 300 m at the mouth. The coastal plain and a great part of the inland territory are constituted by seven orders of marine terraces (HUGONIE, 1974): they are diffused from this coastal plain up to 700 m level. SanFratello Mt. presents, in its Northern sector, a well squared geometrical trend, with sub-vertical walls originated by two main fault systems, NNW-SSE and NNE-SSW directed. Epigeal karst is characterized by scarcely developed morphologies, uncompleted and roughly incised. Hypogean karst is represented by a group of cavities, located along tectonic lines, testifying old aquifers. They evidence traces of

Palaeolithic fauna, with rests of vertebrate skeletons too (*San Teodoro Men* in the omonym grotto, see BACCI, 1989).

In the considered area, formations include portions of a pre-Mesozoic metamorphic basement, together with the relevant sedimentary overburdens of the *Longi-Taormina* Stratigraphic Structural Unit (S.S.U.). This S.S.U. is the lowest unit of the overthrust belt of the Calabrian-Peloritani Arc (NIGRO, 1992). The Oligocene-Miocene Numidian Flysch outcrops in the Western part of the region: it is constituted by a sequence of quartzarenites with calcareous cement and argillites. The *Monte Soro Flysch*, widely extending in the Southern sector, is mainly represented by sequences of fine grain feldspatic quartzarenites and shales. The *Longi-Taormina Unit* includes a phyllite basement and an overburden constituted by conglomerates and quartzites, fine grain limestones with siliceous elements, dolomites and marls. Unconformable terrains of *Capo d'Orlando Flysch* occur in the region, formed by graded arenite banks with rare clayey interbeddings and thick conglomerates.

These different formations have very complicated layering relations, due to the compressive tectonic interesting the Nebrodi belt and the successive Pliocene-Quaternary distensive tectonics that have divided the relieves in blocks and steps (DUEE, 1969, BONFIGLIO, 1987). The described sediments, on the whole, are covered by coarse detritus, carried to the sea by the torrents (locally named *fiumare*) and by the wave work. They are successively re-deposited along the coast.

3. Hydrogeological setting

Water resources of Nebrodi region are considered to be scarce, due to the large extension of flyshoid and metamorphic outcrops. Nevertheless, Authors consider the great importance of the karst units, that have in this area a notable extension. Karst groundwaters are not adequately explored and exploited, leaving the crowded coastal villages without a sufficient amount of waters for the different purposes. Synoptic table n. 1 and figure 1 want to demonstrate the importance of the karst

1) Research executed with a grant of the Italian National Research Council, Strategic Project "Criticism of water availabilities to be utilized for potable purposes", publ. no. 41.

reservoirs in the Nebrodi region with respect to the water resources of whole Sicily.

The hydrogeological units of the region are described in figure 1: the most important formations are the limestones and the torrent and sea alluvions in the coastal sectors (*Hydrogeological Unit of San Fratello* and *Hydrogeological Unit of Acquedolci Plain*). The Hydrogeological Unit of San Fratello can be considered an autonomous unit because it is limited by impervious terrains, that partially tampon karst groundwater flows towards the plain of Acquedolci. Part of these waters rises in springs, originated by contact or tectonic unconformity. The most productive of springs is the *Favara spring*, located at the boundary of the San Fratello karst complex, in a zone characterized by formations with different permeability. The yield of this spring, that has an average value of 15 l/s, is strongly influenced by rainfalls. This is likely due to the short distance with the supply zone.

The Hydrogeological Unit of Acquedolci Plain is characterized by a sandy-gravelly-arenaceous aquifer. The trend of groundwaters depends on the morphology of the impervious substratum as well as on the granulometry features of the alluvial deposits: these are subjected to frequent lateral and vertical facies changes, mainly along the foothill belt. These unit is supplied by direct precipitations as well as limestone flows. A further supply comes from the fluvial groundwaters circulating in the permeable beds of the Furiano Torrent course. Springs located in the alluvial deposits have a minor importance, with a comprehensive yield of 1.5 l/s. A lot of wells intensely exploit the aquifer, mainly for irrigation purpose. Overpumpings of groundwaters cause a sea encroachment, evidenced by the chemical analyses of well waters along the coast. In certain sectors, groundwaters present an exceptional concentration of Na and Cl ions. The alluvions relevant (at left in figure 2) to the Furiano Torrent

belong to this unit too, with high porosity and permeability: they also supply wide sectors of the coastal belt. Groundwaters in these torrent deposits, close to flyshoid outcrops (see figure 1), have a chemical trend towards a HCO₃-Na type; Cl-Na trend characterizes groundwaters close to the coastal line. Clayey, metamorphic and flyshoid formations constitute the impervious units of the area, with a scarce, local water circulation: they assume an effective importance when limit permeable units. In particular, as quoted above, the *Argille Variagate Unit* represents the impervious bed to the Hydrogeological Unit of Acquedolci Plain.

Figure 3 shows the isophreatic lines deduced from well data relevant to a recent inventory. The investigated portion of the Acquedolci area corresponds to the rectangle indicated in the upper part of figure 2. The higher gradient in the central sector of the map is related to the notable supply to the plain from the karst San Fratello complex, in spite of the tamponing by the clays outcrops of the *Argille Variagate Unit*. The higher permeability of the torrent sediments (Furiano Torrent) with regard to sands and arenites causes a lower gradient of the isophreatic lines in the Western sector of the Plain.

4. Geochemical and geophysical surveys

This paper represents the second contribution towards an approach to a better hydrogeological knowledge of the Acquedolci area (ABBATE *et al.*, 1994). Here Authors extend geochemical and geophysical prospectings, trying a correlation with the hydrogeological information. The interest offered by this region is justified by the local vulnerability of alluvial and karst units, shown in figure 2: they are considered highly vulnerable in consideration of their good permeability. A contamination risk along the very peopled coastal belt is present for sea intrusion from the North. The permeability of the limestone units creates another contamination possibility

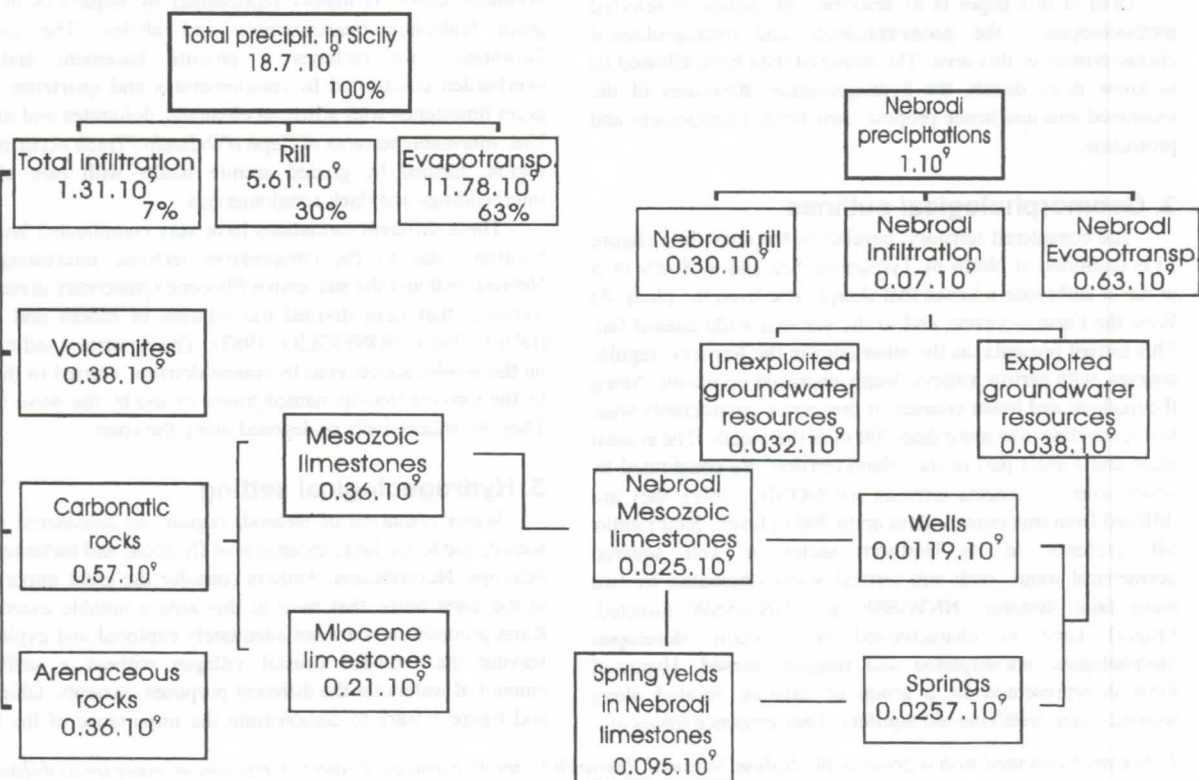

Tab. 1: Synoptic table representing the water potentiality of Nebrodi limestones with respect to whole Sicily. Yearly average values are in m³.

in the mount zones, especially for the springs supplied by karst groundwaters. In order to elaborate a vulnerability map of the area, inventories of the main hydrogeological and geophysical parameters have begun in these last years. Table 2 shows the analyses of two water samplings of springs, carried out in two different periods. They generally indicate an intermediate mineralization, with a Ca/Mg ratio always below unit. In particular, the spring waters, relevant to the karst reservoir of San Fratello Mt., are classified as bicarbonate-alkaline earth. Indeed, the prevalent concentrations of Ca and HCO_3 ions and the high pH values are characteristic of a carbonate aquifer,

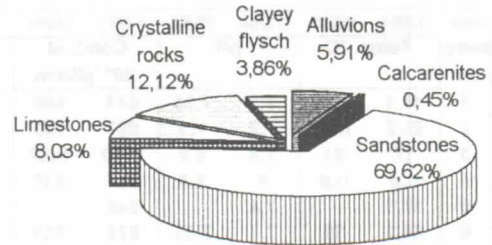

Fig. 1. Diagram showing the rock distribution in the Nebrodi region.

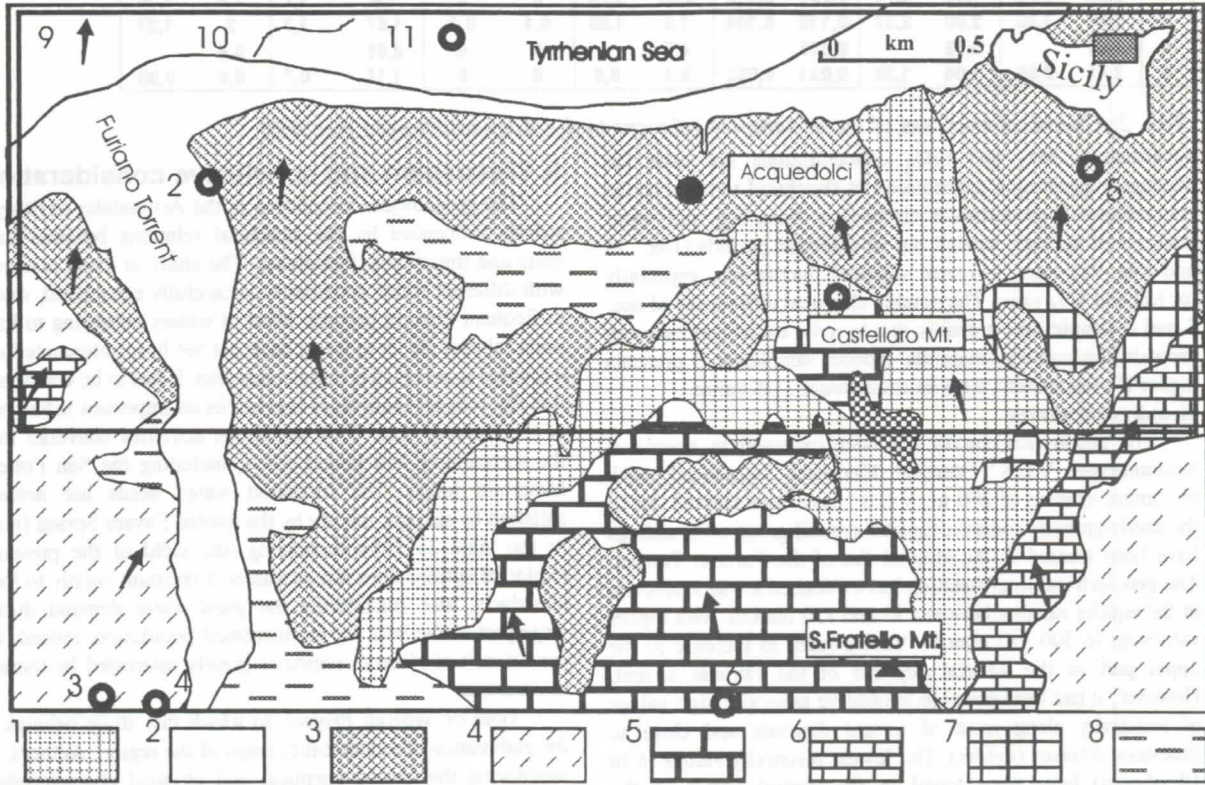

Fig. 2: Hydrogeological structures and elements of the Acquedolci area (East Sicily). 1: Debris (Holocene); 2: coastal and fluvial deposits (Pliocene-Quaternary); 3: sandy-gravelly complex (Pliocene-Quaternary); 4: clayey-marly-arenaceous flysch (Cretaceous-Miocene); 5: limestones and 6: limestones-marls of the "Longi Taormina" S.S.U. (Lias-Eocene); 7: metamorphic complex of the "Longi-Taormina" S.S.U.; 8: clays of "Argille Variegate" unit (Cretaceous); 9: water-flow directions; 10: permeability boundaries; 11: sampled springs. Upper rectangle delimits area relevant to figure 3

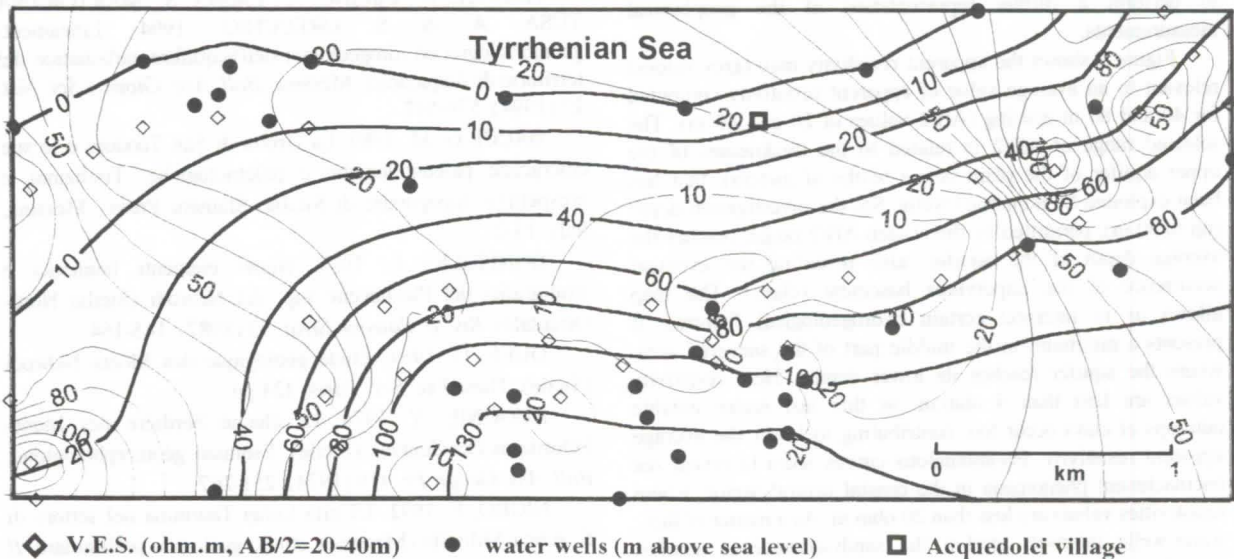

Figure 3: Contour lines of groundwaters (black) and average apparent resistivity (gray) in the Acquedolci plain

date	12/94	08/95	12/94	08/95	12/94	08/95	12/94	08/95	12/94	08/95	12/94	08/95	12/94	08/95	12/94	08/95
samp No.	Temp. °C		pH		Cond. at 20° µS/cm		Ca meq/l		CO ₂ meq/l		Hardness		SiO ₂ mg/l		TDS at 180°C mg/l	
1	18,1	18	7,3	7,35	541	500	3,26	2,80	0,32	traces	26,9	27,5	8,22	9,91	303	354
2	20,2	n.d.	7,2	7,1	887	683	5,30	4,40	0,18	0,00	36,7	31,3	7,66	7,99	552	457
3	17	21	7,4	6,9	1492	1467	8,81	7,30	0,69	0,00	70,55	74,0	12,38	14,70	1097	1190
4	n.d	n.d	8	8,3	604	510	2,65	1,96	0,00	0,00	20,2	17,3	23,40	23,19	371	297
5	17,6		7,4		545		2,90				26,55		10,59		315	
6	14,3	19	7,1	7,35	876	849	6,24	6,55	0,46	0,62	43,25	47,5	15,60	16,00	541	544
	Mg meq/l		Na meq/l		K meq/l		HCO ₃ meq/l		CO ₃ meq/l		Cl meq/l		SO ₄ meq/l			
1	2,12	2,70	0,75	0,98	0,077	0,068	4,8	4,9	0	0	0,7	0,7	1,4	0,31		
2	2,04	1,86	2,61	2,32	0,110	0,068	4,25	3,7	0		1,64	0,8	2,95	2,97		
3	5,30	7,50	4,35	4,70	0,384	0,320	9,25	8,75	0	0	1,8	1,7	7,6	9,16		
4	1,39	1,50	2,00	2,32	0,115	0,104	1,8	1,85	0,1	0,1	1,67	1,8	2	1,27		
5	2,41		0,78		0,036		4,7		0	0	0,85		0,4			
6	2,41	2,95	1,04	1,28	0,021	0,002	9,1	8,5	0	0	1,17	0,7	0,9	0,98		

Tab. 2: Chemical analyses of water samples relevant to the Acquedolci area (see text)

nevertheless, SO₄ and SiO₂ concentrations are over the average, suggesting a contribution of flyschoid terrains to the comprehensive groundwater circulation. Sampling and water analyses of springs, carried out in different periods (Dec. 94 and Aug. 95), seem to reveal seasonal fluctuations, especially for Mg and SO₄ ions. The notable chemical differences of nos. 3 and 4 samples are probably due to ionic exchanges between groundwater and clay minerals: indeed, sample no. 3 presents higher Na ion content, with an exceptional TDS value.

Geophysical survey

The geophysical survey has been executed by means of Schlumberger V.E.S.' (Vertical Electrical Soundings), with maximum spacing of 200 m. V.E.S.' have been carried out in the sandy-gravelly coastal deposits; a small group of soundings have been located in the alluvial fan of the Furiano Torrent. The geoelectrical interpretation has evidenced a true resistivity of the aquifer ranging between 50 and 150 ohm.m, with higher values up to 300-350 ohm.m. Values seem to increase in the upper part of the alluvial deposits of the Furiano torrent. However, it has been possible to observe generally high values of resistivity along most of torrent deposits and close to limestone relieves (debris). The lowest resistivity values (5 to 10 ohm.m) have been found in the central sector of the investigated area. Geoelectrical quantitative interpretation has been relatively easy: indeed, the beddings of the area, at least for the upper strata, generally permit to apply the simplest model, based on the horizontally layered situation. Nevertheless, in order to overcome the difficulties connected with the theoretical geoelectrical model, Authors have chosen to perform a further representation of the geophysical measurements.

Figure 3 shows the apparent resistivity map (grey values) relevant to an average value of apparent resistivity computed for 40 and 80 m spacing (AB/2 values of 20 and 40 m). The selected range of AB/2 is related to the thicknesses of the upper aquifer of the plain (some tenths of meters), that has been exploited by numerous wells. So, the investigation depth (up to 30 m), permitted by the chosen AB/2 range, reaches the average depth of the aquifer, also revealing the eventual occurrence of the impervious basement (clays). The map allows us to interpret certain hydrogeological features. It presents a minimum in the middle part of the surveyed area, where the aquifer reaches its lower depths. Here resistivity values are less than 5 ohm.m: in this last sector notable outcrops of clays occur too, contributing to lower the average apparent resistivity. Iso-anomalous curves seem to reveal sea encroachment phenomena in the coastal central sector, where resistivities values are less than 20 ohm.m. As a matter of fact, water-wells intensely exploit the sandy-arenaceous aquifer, with the risk of chlorine contamination for a wide area.

5. Discussion and conclusive consideration

The groundwater circulation in the Acquedolci territory is strictly influenced by the structural relations between karst units and impervious formations. The study of these resources with different water potentiality is carefully considered, owing to frequent drought periods. Most of waters belonging to karst units (almost 26 l/s in total) have not yet been intercepted and exploited to adequately supply this area. It has to be considered that the area of Acquedolci constitutes an important urban pole of the Nebrodi area. Here numerous activities converge from the surrounding and inland zones, including the San Fratello Mountain range. The increased water needs are actually satisfied by springs, mainly by the quoted Favara Spring (no. 1 in the table 2). Notwithstanding, the yield of the presently exploited springs does not guarantee a constant supply to local aqueducts, also considering the great water demand during large part of the year for the increased population. Indeed, the coastal belt of Nebrodi region is greatly interested by tourism movements.

Goal of *Nebrodi Project*, to which this study belongs, is the elaboration of vulnerability maps of the region. Authors, by monitoring the quoted chemical and physical characteristics, consider necessary to survey and protect groundwaters: they could constitute, in a next future, the sole water resources of good quality of the whole region, especially in coastal sectors. The first results, here exposed in form of tables and maps, encourage towards a further collection of periodical data.

References

- ABBATE, R.; CIMINO, A.; EMMA, S.; MARTORANA TUSA, A. & S. ORECCHIO. 1994. Lineamenti geomorfologici ed idrogeologici dell'acquifero carbonatico del territorio di Acquedolci, Messina. *Boll. Acc. Gioenia Sci. Nat.* 27 (1994): 579-597.
- BACCI, G. M. 1989. La Grotta di San Teodoro e le sue emergenze paleontologiche e paleontologiche. Tradizioni e prospettive. Ippopotami di Sicilia, Sfameni Press., Messina, Italy: 13-21
- BONFIGLIO, L. 1987. Nuovi elementi faunistici e stratigrafici del Pleistocene sup. dei Nebrodi (Sicilia Nord-Orientale). *Riv. It. Paleont. Strat.* 93 (1987): 145-164.
- DUEE, G. 1969. Etude géologique des Monts Nebrodi (Sicile). Thèse Fac. Sci., Paris, 424 pp.
- HUGONIE, Y. 1974. La chaîne bordière des Monts Péloritains Occidentaux (Sicile). Esquisse géomorphologique. *Bull. Ass. Géogr. Fr.* 419 (1974): 251-267.
- NIGRO, F. 1992. L'Unità Longi-Taormina nel settore di S. Agata Militello (Messina): studio geologico preliminare. *Il Naturalista Siciliano* 16 (1992): 63-89.

EPIK, méthode de cartographie de la vulnérabilité des aquifères karstiques pour la délimitation des zones de protection

par Nathalie Doerfliger et François Zwhalen

Centre d'Hydrogéologie, Université de Neuchâtel, 11 rue E-Argand, 2007 Neuchâtel, Switzerland.

Résumé

La méthode EPIK est une méthode générale multicritère utilisée pour cartographier la vulnérabilité des aquifères karstiques et pour servir de base à l'établissement des zones de protection en milieu karstique. L'objectif de cette méthode développée avec la contribution de l'Office fédéral de l'environnement, de la forêt et du paysage (OFEFP) est de produire des cartes de vulnérabilité pour des sources ou captages en milieu karstique. Les zones de vulnérabilité obtenues servent de base à la délimitation des zones de protection. Après avoir déterminé le bassin d'alimentation de la source, on procède en quatre étapes: 1) cartographie de l'Épikarst (approche morphologique), 2) Cartographie de la couverture protectrice, 3) cartographie des conditions d'infiltration et 4) caractérisation du développement du réseau karstique. Chacun des ces quatre critères est subdivisé en classes pondérées chacune par un coefficient théorique. La "superposition des cartes" par un système d'information géographique SIG des quatre critères et le calcul de chacune des zones résultantes permet d'obtenir une carte finale de la vulnérabilité. Cette méthode a fait l'objet des tests sur plusieurs sites en Suisse dont quelques résultats sont présentés ici.

Abstract

The EPIK method is a general multiattribute method used for the karst aquifer vulnerability mapping and to provide a base to assess the groundwater protection zones in the karst environment. The goal of this method developed with the support of the Federal Office for Environment, Forest and Landscape is to produce some vulnerability maps for karst spring watercatchments. According to the selected attributes, the obtained vulnerability zones can be a base to outline the groundwater protection zones. After having determined the spring watercatchment borderlines, we proceed in four steps: 1) mapping of the epikarst (geomorphological approach), 2) protective cover mapping, 3) infiltration conditions mapping and 4) characterization of the karst network development. Each of this attribute is subdivided in classes that are weighted by a theoretical coefficient. The four attributes maps are overlaid using a GIS and for each zone vulnerability degree is calculated; the resulting map is the vulnerability map. This method was tested in Switzerland on several sites, whose some results are here introduced.

1. Introduction

Les ressources en eau en milieu karstique sont importantes pour l'approvisionnement en eau dans la plupart des pays du monde, mais sensibles aux impacts anthropogènes, elles sont considérées comme vulnérables.

Cette vulnérabilité s'explique notamment par la structure fortement hétérogène des aquifères karstiques, avec d'une part des perméabilités très élevées dans les conduits souterrains entourés de blocs peu perméables et d'autre part des alimentations de surfaces localement très concentrées.

Vulnérabilité des aquifères

La vulnérabilité est une propriété intrinsèque des aquifères qui dépend de la sensibilité de ces derniers aux impacts naturels et anthropogènes (FOSTER S.S.D. 1987). Elle est utilisée pour caractériser, à l'aide d'information d'origine géologique et hydrogéologique, la sensibilité des aquifères aux contaminations anthropogènes, que ce soit sous forme ponctuelle ou diffuse.

Protection spécifique

Du fait de leur fonctionnement spécifique et de leur vulnérabilité, les aquifères karstiques requièrent une protection toute particulière. La loi fédérale relative à la protection des eaux de 1993, exige la délimitation des zones de protection S pour tous captages utilisés pour l'alimentation en eau potable: en milieu karstique leur délimitation repose principalement sur des critères morphologiques et quelques vitesses de transit établies par essais de traçage (Instructions pratiques pour la délimitation des zones de protection, 1977). Si la réalisation des zones de protection de tous les captages en Suisse est pratiquement terminée, malgré ce grand effort, la

protection des captages en zone karstique n'est encore souvent qu'imparfaite.

Au vu de cette situation, il s'est avéré nécessaire de proposer et de développer une méthode de cartographie de la vulnérabilité des aquifères karstiques à partir des différents critères spécifiques du comportement hydrodynamique du système karstique. Cette méthode se veut être objective; elle est basée sur des critères géologiques et hydrogéologiques et est indépendante de l'occupation du sol et des considérations économiques.

2. Approche multicritère : la méthode EPIK

L'approche proposée ici pour évaluer la vulnérabilité des bassins d'alimentation des sources karstiques est une approche multicritère à index, appelée EPIK; elle prend en compte 4 critères, correspondant à quatre caractéristiques spécifiques du fonctionnement d'un aquifère karstique tel qu'il est décrit ci-dessous.

Après avoir déterminé les limites du bassin d'alimentation de la source, on procède en quatre étapes: 1) cartographie de l'épikarst, 2) cartographie de la couverture protectrice, 3) cartographie des conditions d'infiltration et 4) caractérisation du développement du réseau karstique et attribution d'un facteur global au bassin d'alimentation. La cartographie des critères subdivisés en indices s'effectue à l'aide de méthodes directes ou indirectes, locales ou globales telles que l'étude géomorphologique, l'utilisation d'un modèle d'altitude numérique, des sondages à la tarière, l'interprétation de photos aériennes, de la géophysique, des essais de traçage.

Fonctionnement d'un aquifère karstique

Les aquifères karstiques sont caractérisés par des particularités géomorphologiques, des phénomènes hydrauliques tels que l'existence d'importantes sources, de pertes, l'absence de réseau de drainage de surface, l'existence de réseaux karstiques et d'hydrogrammes typiques de source. A partir de ces caractéristiques, on peut proposer l'image suivante d'un aquifère karstique schématisé à la figure 1 :

"Un réseau de conduits connexes (réseau karstique) aboutissant à des exutoires drainant ou alimentant des volumes de roche fissurée et fracturée de faible perméabilité".

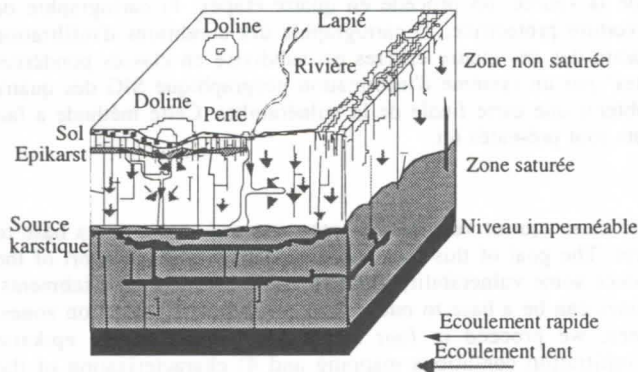

Figure 1: Représentation schématique du fonctionnement d'un aquifère karstique (DOERFLIGER et al., 1995).

Les critères de la méthode EPIK

A partir de ce schéma, 4 critères des plus pertinents sont différenciés comme suit :

Critère E: Epikarst (morphologie karstique)

- E1** - Gouffres et dépressions absorbants un cours d'eau
- Dolines
 - Lapiez
 - Cuestas
 - Affleurements avec fracturation intense (bord de route / affleurement artificiel)
- E2** - Zones intermédiaires entre les alignements de dolines
- Vallées sèches
- E3** - Le reste du bassin d'alimentation

Critère P: Couverture protectrice

A. Sol reposant directement sur les formations calcaires aquifères ou sur des formations détritiques grossières très perméables (Ex. éboulis, moraines latérales...)

- P1** - 0 - 20 cm de sol
P2 - 20 - 100 cm de sol
P3 > 100 cm de sol

B. Formations géologiques peu perméables avec ou sans sol (Ex. limons lacustres, argiles...)

- P3** -> 100 cm au total de sol et formations géologiques peu perméables

P4 -> sol avec d'épaisses [8mètres] formations géologiques de très faible perméabilité [limons-argileux-silteux] (à vérifier de manière ponctuelle)

Critère I: Conditions d'infiltration

- I1** - Pertes pérennes et temporaires
- Lits et rivages des cours d'eau
 - Cours d'eau pérennes et temporaires alimentant une perte ou une doline
 - Cours d'eau infiltrants

A/ A l'intérieur du bassin versant des cours d'eau alimentant des pertes

- I1** - Partie du bassin versant drainée artificiellement
I2 - Partie du bassin versant non drainée artificiellement et dont la pente est supérieure à 10 % pour les zones de culture, 25 % pour les prés et les champs
I3 - Partie du bassin versant non drainée artificiellement et dont la pente est inférieure à 10 % pour les zones de culture, 25 % pour les prés et les champs

B / Hors des bassins versants des cours d'eau alimentant des pertes

- I3** - Surfaces au pied d'une pente jouant le rôle de collecteurs des eaux de ruissellement et pentes alimentant ces points bas (pentes supérieures à 10 % pour les zones de culture, 25 % pour les prés et les champs)
I4 - Le reste du bassin d'alimentation

Critère K: Réseau karstique

- K1** - Réseau karstique bien développé, à conduits décimétriques à métriques très peu colmatés et bien connectés
K2 - Réseau karstique mal développé, à drains ou conduits mal connectés ou colmatés, ou encore de dimension décimétrique et inférieure
K3 - Exutoire en milieu poreux avec effet protecteur (à vérifier)
 - Aquifère fissuré non karstifié

Pondération de la vulnérabilité

Pour chacun des critères E - P - I et K, on établit une carte de distribution spatiale de leurs indices. Ces 4 cartes sont digitalisées et transformées en format image (raster); ce format permet d'attribuer à l'aide d'un Système d'information géographique, les valeurs des classes en toute cellule du bassin. Ce dernier est quadrillé selon une maille de 20 mètres de côté. Puis les cartes sont superposées les unes aux autres: les valeurs des indices des classes sont additionnées et multipliées par le poids relatif, afin d'obtenir une carte synthétique de vulnérabilité (DOERFLIGER, 1996), selon l'équation de pondération ci-dessous :

$$F = \alpha E_i + \beta P_j + \gamma I_k + \delta K_l \cdot (1)$$

avec F: facteur de protection
 E_i, P_j, I_k et K_l: valeurs des indices de chaque classe des critères / α, β, γ, δ: coefficient de pondération relative

Pour attribuer des valeurs aux coefficients de pondération, nous avons effectué différents tests de sensibilité et pris en compte notamment les considérations suivantes et :

-Une doline recouverte d'un sol épais (E1-P3) est plus vulnérable qu'une dalle calcaire compacte surmontée d'une mince couverture pédologique (E3-P1)

-Un cours d'eau alimentant une perte (I1) est très vulnérable, indépendamment de la couverture protectrice.

-Une vallée sèche (E2) est aussi vulnérable qu'un point topographiquement bas jouant le rôle de collecteur des eaux de ruissellement

En tenant compte de ces considérations et des différents essais de pondération effectués, les valeurs suivantes ont été retenues pour le calcul du facteur de protection :

1. Les indices des critères E, P, I et K sont pondérés ainsi :

E ₁	E ₂	E ₃	P ₁	P ₂	P ₃	P ₄
1	3	4	1	2	3	4
I ₁	I ₂	I ₃	I ₄	K ₁	K ₂	K ₃
1	2	3	4	1	2	3

Rappel : La valeur de pondération la plus basse correspond à la situation la plus vulnérable

Tableau 1 : Pondération des indices des critères E, P et I.

2. Les critères E et I jouant un rôle moins important sur la protection du karst que le critère P, nous leur avons attribué un poids relatif plus important (vulnérabilité plus grande). Le poids attribué au critère E par rapport au critère I est identique. K a un poids relatif qui est situé entre celui de E et P.

α	β	γ	δ
3	1	3	2

Tableau 2 : Poids relatifs attribués aux critères E, P et I.

3. Lors du calcul du facteur de protection F pour les différentes combinaisons possibles, on obtient alors des valeurs allant de 19 à 34. Les combinaisons suivantes des classes des critères donnés sont incompatibles: K_i avec E₁, I₁ et P₃ ou P₄.

Détermination des zones de protection

La combinaison des différents facteurs de pondération propres à chaque critère selon l'équation ci-dessus permet d'attribuer en tous points du bassin d'alimentation l'une des trois zones de protection S.

F inférieur ou égal à 19	Zone S1
F entre 20 et 25	Zone S2
F > 25	Zone S3

Tableau 3: Equivalence Vulnérabilité et zones de protection .

3. Exemples d'application

Deux exemples d'application sont présentés. Il s'agit de la cartographie de la vulnérabilité du bassin d'alimentation des sources (Clarive et Tine) de la commune de St-Gingolph (VS) dans les Préalpes médianes plastiques et de la cartographie de

la vulnérabilité d'une partie du bassin d'alimentation des sources du Saivu, de la Font et de la Bâme à Bure dans le Jura Tabulaire (NW de la Suisse).

St-Gingolph - Préalpes valaisannes

Dans ce cas des pollutions fréquentes d'origine agricole (fumier et purin) affectent la qualité des sources de la Clarive et de la Tine. L'application de la méthode EPIK sur ce critère a pu mettre en évidence la relative importante vulnérabilité de ce bassin - surface considérable de zones de vulnérabilité moyenne à élevée (Figure 2). Le bassin d'alimentation est caractérisée par la présence majoritaire de la zone de protection S2 (Figure 3).

Bure - Jura Tabulaire

Dans le cadre de l'étude d'impact de la future route nationale N16, le bassin karstique des sources de La Font, du Saivu et de la Bâme a fait l'objet d'importantes études, hydrogéologiques notamment. Ce bassin (quelques 15 km²) se situe en Ajoie, dans le Jura tabulaire (aquifère développé dans les calcaires du Séquanien inférieur). Les eaux de ce site sont drainées par un réseau karstique souterrain, La Milandrine.

Les trois critères E, P, I ont été caractérisés à l'aide des données existantes à disposition (géophysique, levés de forages, photos aériennes,...) et des travaux de terrain (cartographie, sondages à la tarière à la main,...). Des études complémentaires (géophysique, forages, essais de traçage...) ont également été réalisées avec pour objectif de tester de manière approfondie la méthode EPIK. Les résultats obtenus suite à ces différents travaux de terrain ont permis d'apprécier les avantages de la nouvelle méthode (DOERFLIGER et al., 1996).

4. Conclusions et perspectives

La méthode EPIK est un outil tout à fait adapté à la gestion des ressources en eau en milieu karstique. Elle permet d'obtenir des cartes spécifiques de vulnérabilité; ces cartes constituent une nouvelle base pour l'établissement des zones de protection en terrain karstique. Les zones de protection sont ainsi mieux ciblées, en particulier les zones les plus restrictives (S1).

Combinée à une carte des risques potentiels, les cartes EPIK devraient à l'avenir faciliter l'établissement d'un règlement approprié relatif aux zones de protection en milieu karstique. Les exemples d'application de cette méthode sur plusieurs sites tests, ont démontré la faisabilité de cette nouvelle approche en terrain karstique.

A ce jour, le concept d'établissement de ces nouvelles cartes est relativement clair et les recherches actuelles s'orientent sur la caractérisation de l'épikarst (cf. PUECH, 1997, in ce colloque) et le transit de contaminants donnés dans la couverture protectrice.

La contamination des aquifères karstiques n'est pas une fatalité. Une délimitation des zones de protection en adéquation avec le fonctionnement hydrogéologique du karst, contribue grandement à la protection des sources et ressources en eaux souterraines karstiques.

Remerciements

Les auteurs de cet article remercient vivement l'Office fédéral de l'environnement, des forêts et du paysage ainsi que le Service hydrologique et géologique national pour le soutien apporté lors du développement de cette méthode EPIK, ainsi que les membres du groupe karst de la société suisse d'Hydrogéologie. Nos remerciements vont également au canton de Berne, Office de l'économie hydraulique et énergétique du canton de Berne .

Références bibliographiques

DOERFLIGER N et ZWAHLEN F. 1995. EPIK: a new method for outlining of protection areas in karstic environment. International Symposium on Karst Waters and Environmental impacts, Antalya, 10-20 September 1995. Sous presse chez Baikema.

DOERFLIGER N, Tâche E. et ZWAHLEN F. 1996. EPIK, une méthode pour cartographier la vulnérabilité des aquifères karstiques: application à deux sites dans le Jura suisse. ESRA'96, L'eau souterraine en région agricole, colloque, Poitiers, 9-12 septembre 1996, S7-17-20.

DOERFLIGER N. 1996. Advances in karst groundwater protection strategy using artificial tracer test analysis and

multi-attribute vulnerability mapping (EPIK method). Thesis, University of Neuchâtel, Switzerland, 225pp.

FOSTER S.S.D. 1987. Fundamental concepts in aquifer vulnerability, pollution risk and protection strategy. IN Vulnerability of soli and groundwater to pollutants (W. van Duijvenbooden and H.G. van Waegeningh, eds). TNO Committee on Hydrological Research, The Hague, Proceedings and Information, No 38, pp. 69-86.

Instructions pratiques pour la détermination des secteurs de protection des eaux, des zones et des périmètres de protection des eaux souterraines. 1977, révision partielle en 1982. Office fédéral de la protection de l'environnement.

$$F = E_i \cdot 3 + P_j + I_k \cdot 3 + K_l \cdot 2 \quad \text{avec } i = 1, 3, 4 - j = 1, 2, 3, 4 - k = 1, 2, 3, 4 - l = 1, 2, 3.$$

Rappel :

- Valeur basse = très vulnérable
- Valeur élevée = peu vulnérable

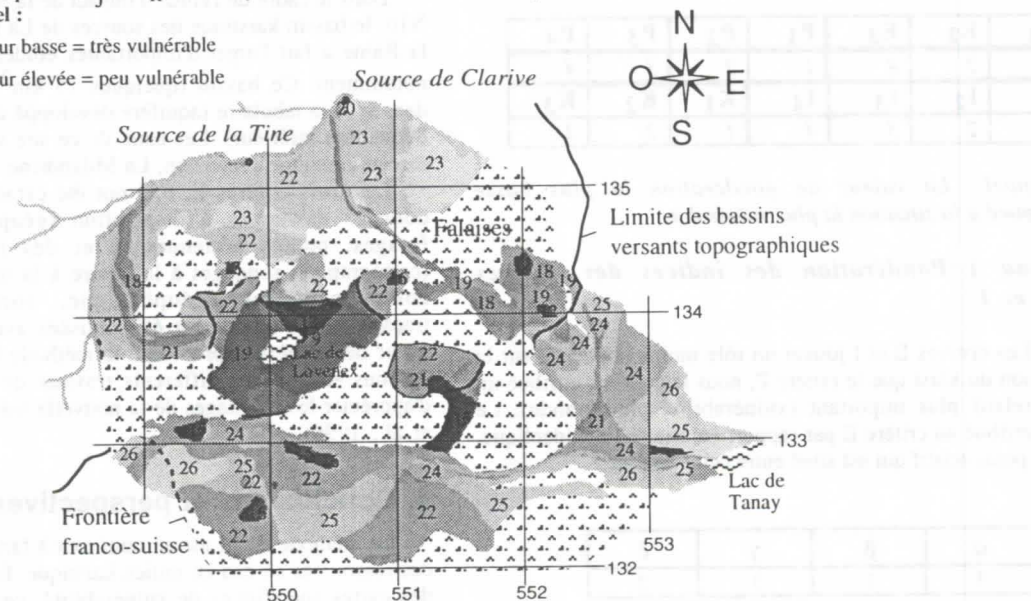

Figure 2: Carte de la vulnérabilité du bassin d'alimentation des sources de la commune de St-Gingolph (VS).

- S1 = facteurs de protection entre 9 et 19
- S2 = facteurs de protection entre 20 et 25
- S3 = facteurs de protection entre 26 et 32

Légende

- S1
- S2
- S3

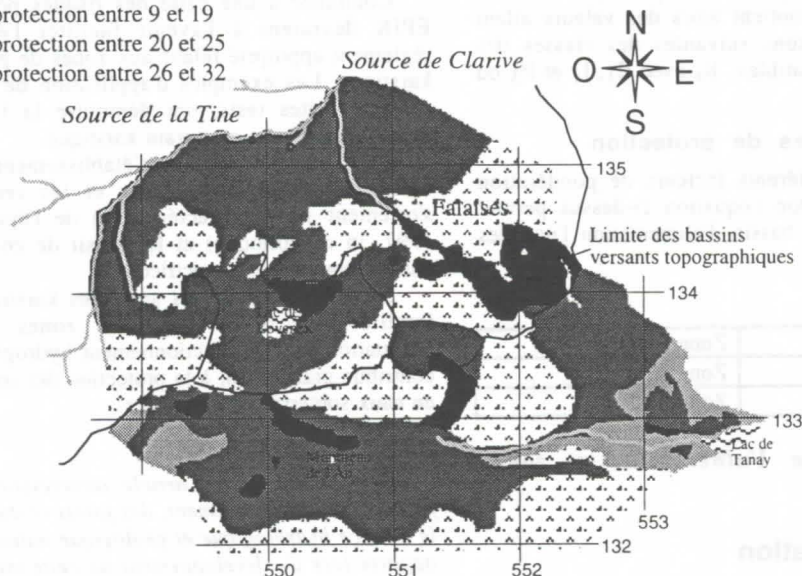

Figure 3: Carte des zones de protection du bassin d'alimentation des sources de la commune de St-Gingolph (VS).

Contaminant transport from leaky landfills in karst areas

Matthias Eiswirth & Heinz Hötzl

Department of Applied Geology, University of Karlsruhe, Kaiserstraße 12, 76128 Karlsruhe, Germany

Abstract

The transport and fate of contaminants from leaky landfills in karst areas have been investigated by soil gas surveys and geophysical methods. One investigation area was a municipal landfill above karstified limestones of Triassic age, Northern Black Forest, South Germany. Research work was focused on the detection of hypothetical contaminant flow paths from the landfill to a karst spring north of the landfill, which is subject to severe pollution. Therefore detailed hydrogeological and geophysical investigations have been carried out to detect contaminant flowpaths from the leaky landfill. The detailed soil gas screenings on the selected investigation profiles allowed, in combination with geophysical methods, the detection of fault zones as well as the further run of preferential flow paths of leachate and contaminated groundwater in the karstic limestones.

1. Introduction

Leachates leaking from damaged landfills represents a potential threat for groundwater and becomes more and more a matter of public concern. Old landfills with no or insufficient leachate collection systems constitute a frequent risk to groundwater quality. Leachates and gases percolate downwards and dilute and attenuate passing through the unsaturated zone beneath the site. Such processes include both biological and physicochemical reactions. A significant benefit of an unsaturated zone below leaky landfills is controlling the seepage of leachate into the saturated zone, such that the residual contaminant load is balanced by a continuous supply of oxygen and dilution which may be available in the groundwater too. Unsaturated zone calculations must therefore be coupled with determinations of the oxygen supply within the saturated zone. The leachates from old landfills typically contain specific organic pollutants as well as a substantial content of organic matter. The prediction of the total amount of leachate leaking to soil and groundwater is difficult, but the ef-

fects on groundwater might be severe. The Department of Applied Geology AGK is carrying out long-term monitoring of a number of leaky landfills.

This paper details the results of the most recent investigations on the Grötzingen landfill above karstic limestone. One karst spring north of the landfill is subject to severe pollution. Water samples from this spring and groundwater observation wells indicate the existence of an aquifer pollution by waste site leachate. Therefore detailed hydrogeological and geophysical investigations have been carried out to detect the contaminant flowpaths from the leaky landfill.

2. Geology and site investigations

The investigation area was a municipal landfill above karstified limestones of Triassic age, Northern Black Forest, Southern Germany (Fig. 1 and Fig. 2).

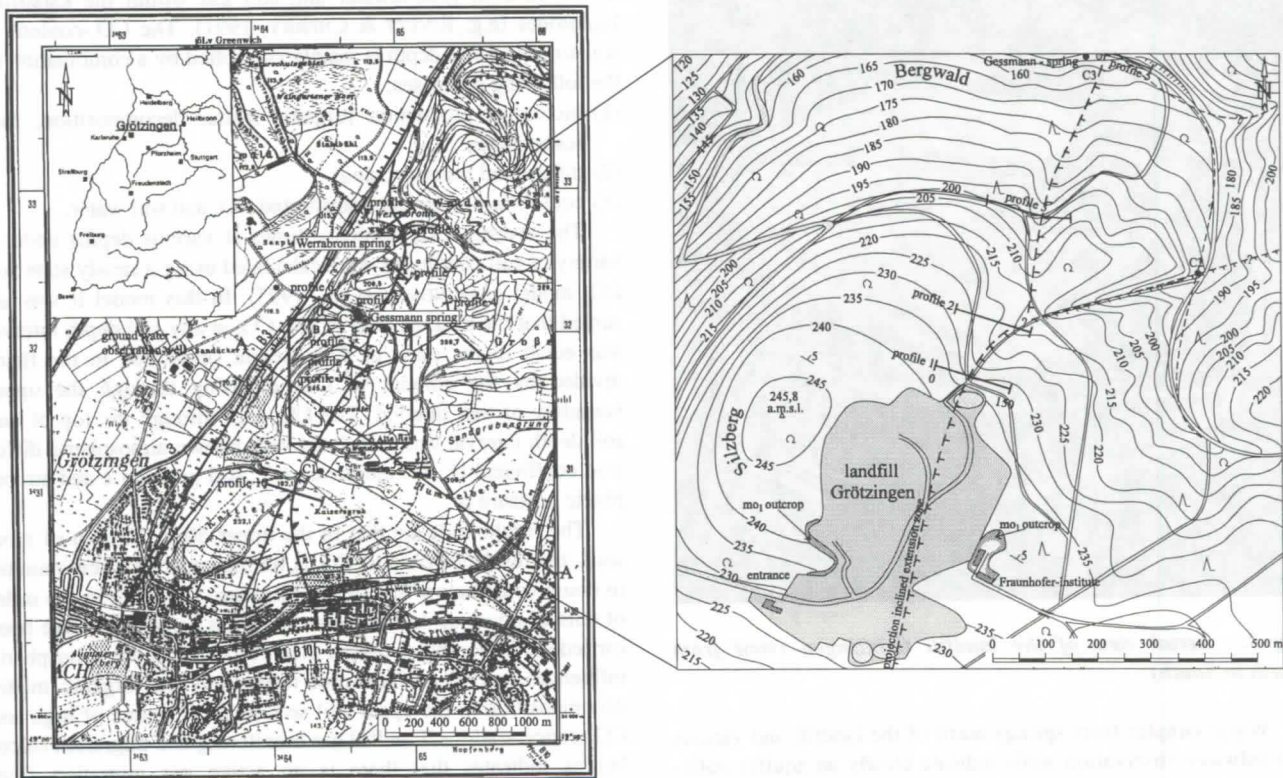

Fig. 1: Map of the landfill Grötzingen in the Northern Black Forest, South Germany. The investigation profiles 1, 2 and 3 are indicated as well as the projection of the extension fault zone.

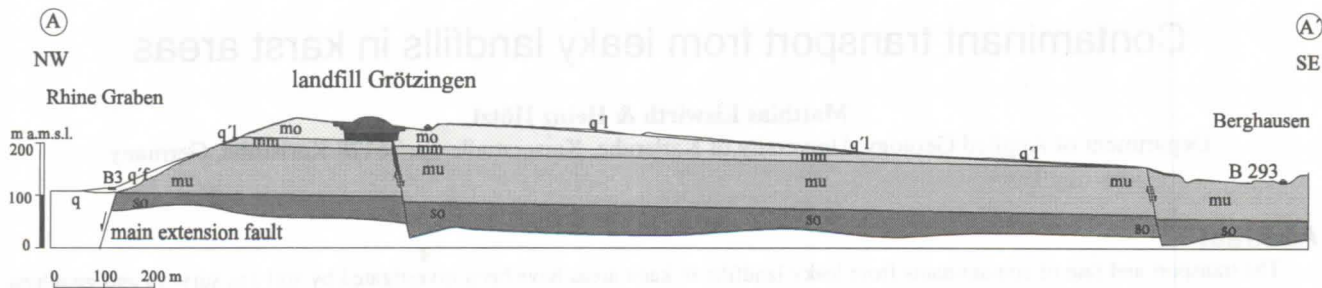

Fig. 2: Geological cross section A-A' as indicated in Fig. 1. (q, q', q'1 = Quaternary sediments, mo = Upper Muschelkalk, mm = Middle Muschelkalk, mu = Lower Muschelkalk, so = Upper Buntsandstein).

The Upper Muschelkalk limestones, quarried at Grötzingen, consists of fine-grained, micritic limestones, intercalated with numerous siltstone and mudstone bands. Fracturing and fissuring within the limestone is extensive and, regionally, secondary permeability is as significant as interstitial flow. The karstified limestones of the Middle and Upper Muschelkalk in the investigation area strikes West to West-East and dips with 5 to 10 degrees North to North-East (Fig. 2). For the hydraulic regime Geological investigations suppose a NNE striking extension fault zone underlying the landfill.

Landfilling of primarily domestic waste commenced in 1973 into the working limestone quarry of Grötzingen (Fig. 3). Historical investigations showed that the former quarry bottom and walls were not correctly sealed before landfilling. Leachate leaks from this areas into the unsaturated limestones. The mean average leachate exfiltration is calculated to 15000 m³·year⁻¹ until 1991 when a 1 m thick impermeable layer was installed above the waste. Even after the completion of this inserted layer about 5000 m³ leachate leaks every year into the underground.

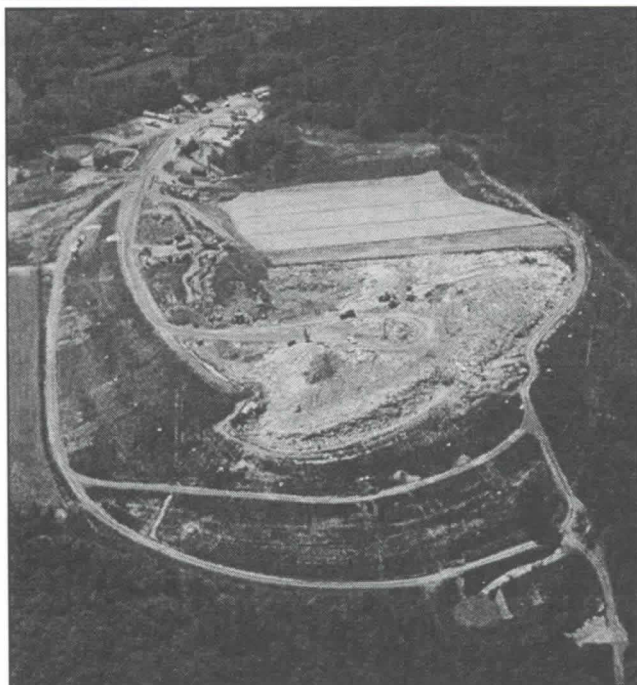

Fig. 3: Aerial view of the landfill Grötzingen (view from North to South).

Water samples from springs north of the landfill and various groundwater observation wells indicate clearly an aquifer pollution by waste site leachate. The leachate front has migrated at a significant distance within the unsaturated zone and groundwater without dominant attenuation and dilution. This indicates that

leachate migration through the unsaturated zone was not in form of an intergranular flow (average flow rate 1-4 m·year⁻¹; LEWIN et al., 1992). Rapid fissure flow on discrete flow paths within the karstified limestones seems to be the dominant leachate transport mechanism below the Grötzingen landfill (EISWIRTH, 1995). Reaching the groundwater the leachate plume is transported mainly on discrete karst flow paths and with the dipping of the limestones into northern-north-eastern direction. Therefore most of the 10 investigation cross-sections were established north of the landfill (Fig. 1).

3. Methodology

Soil gas Screenings

The aerobic biodegradation of leachate compounds in the unsaturated and saturated zone decreases O₂ and increases CO₂ in the soil air and in the groundwater (HENDRY et al., 1992; DEYO et al., 1993). The degradation of leachate compounds on small, preferential flow paths, such as a fault zone, leads to elevated CO₂ and depressed O₂ concentrations (compared to background levels) in both groundwater and soil gas within the karstified limestones (e.g. RIVETT & CHERRY, 1991). The CO₂-content in soil air at any soil depth is mainly controlled by a combination of the following processes:

- (1) biological production (organic matter decomposition, root respiration),
- (2) diffusional transport, and
- (3) equilibration between transported CO₂ and soil water.

The average CO₂ residence times at various depths under a variety of soil conditions were calculated using a steady state soil CO₂ model (AMUNDSON et al., 1995). In this model it was assumed that the average time of soil CO₂ at any soil depth interval was equal to the mass of CO₂ present (measured in the field) divided by the amount of CO₂ diffusing through the upper boundary of that interval. The CO₂-flux through the top of any soil depth interval was calculated with known atmospheric diffusion coefficient D, soil temperature T, soil porosity ε and atmospheric pressure p.

The results indicate that in the upper 50 to 100 cm of most soils, the residence time of CO₂ is on the order of a few minutes to hours while below that depth, residence times are in the order of tens of hours up to 500 hours. Soil gas screenings have been carried out in boreholes deeper than 100 cm to avoid atmospheric influences and to exclude root respiration and organic matter decomposition in the upper soil sequences as source of high soil CO₂-concentrations. Landfill gas monitoring and migration calculations indicates that there is no active gas migration from Grötzingen landfill into the surrounding (METCALFE et al., 1987; BARBER et al., 1990). Measured soil gas CO₂-anomalies correspond therefore to a high diffusional CO₂-transport on fissured

zones, derived from biological organic matter decomposition on discrete contaminant flow paths.

The radioactive noble gas ^{222}Rn ($t_{1/2} = 3.8$ d) is produced by α -decay of ^{226}Ra ($t_{1/2} = 1600$ d), a trace component of all soils. Only a small fraction of totally produced ^{222}Rn escapes from soil particles into soil air depending on the specific soil particle surface and grain size distribution. Gas transport is mainly by molecular diffusion. The ^{222}Rn flux and ^{222}Rn content at the soil surface depends on the ^{226}Ra content, the permeability and diffusion resistance of the unsaturated soil zone and many other parameters e.g. soil temperature, soil moisture, atmospheric conditions (WASHINGTON & ROSE, 1990). The spatial pattern of the ^{222}Rn flux depends more on soil type than on the ^{226}Ra activity of the soil material (DÖRR & MÜNNICH, 1990). Shear zones are commonly enriched in clay material containing uranium minerals and can produce elevated radon concentrations in overlying soils. Elevated ^{222}Rn content in soil gas probes often refers therefore to underlying shear zones and fault zones with high Radon emanation and high rock permeability.

Soil gas surveys were performed on site using portable CO_2 , O_2 , CH_4 and H_2S detectors (Meta, Inc., Altenberge, Germany). ^{222}Rn -activity of the soil gas was analysed with an electronic alpha-particle scintillometer G.B. 83 (Gewerkschaft Brunhilde, Uetze, Germany). With a plastic hydrodermic syringe about 170 ml soil gas was injected into the silver endowed, zinc sulfide coated cell of the scintillometer. The alpha-decays of ^{222}Rn within the cell were detected and counted by a photomultiplier. After calibration of the cell the registered counts per minute cpm can be converted into radon concentration of the soil air [$\text{Bq}\cdot\text{m}^{-3}$]. Gas samples were collected in glass containers or concentrated on charcoal traps. To prevent atmospheric dilution of the soil gas samples, a bentonit slurry was molded around the probes at the surface. By sampling at depths > 90 cm, the effects of barometric pressure, rainfall and air pollution are minimized.

Soil gas sampling was carried out in 10 investigation profiles (150 to 500 m length) in the surroundings of leaky landfills within 1.5 m deep, small diameter boreholes. The boreholes were closed against the atmosphere during the measurements with blowed up packers. The general distance between two measuring boreholes was 10 m. Nearby the supposed extension fault the distance between the boreholes was reduced to 2.5 m.

Electromagnetic soundings

The electromagnetic soundings on the cross sections were carried out with direct current process. Horizontal coplanar and vertical coplanar coil configurations with spacings of 10, 20 and 40 m between transmitter and receiver lead to 6 various depth penetrations (2.5 m to 40m depth) along the cross-sections.

4. Results

The results will be summarised by showing the investigations of profile 1, 2 and 3. Further details on all profiles and on the techniques applied are given in EISWIRTH (1995). In all soil gas screenings both CH_4 and H_2S have been below the detection limits of the instruments used.

Profile 1

During the soil gas investigations on profile 1 soil gas CO_2 maximas were detected at location 73 m and 85 m (Fig. 4). These maximas corresponds clearly with the detected minima in the soil gas O_2 -concentrations. Both positive CO_2 and negative O_2 anomalies refer to contaminant transport on the extension fault zone. The aerobic biodegradation of leachate compounds in the unsaturated and saturated zone decreases O_2 and increases CO_2 in

groundwater and soil air. The elevated CO_2 and depressed O_2 concentrations are caused by biodegradation of leachate in a discrete flow paths within the karstified limestones and overlying high permeable fault zones.

The results of the ^{222}Rn investigations indicate also a main anomaly at location 73 m and three minor anomalies at location 10 m, 85 m and 130 m (Fig. 4). The ^{222}Rn anomaly at location 10 m and 130 m corresponds to areas with a high soil clay content. These areas contain many bricks, but nearly no organic material. The main ^{222}Rn anomaly at location 73 m refers to the extension fault zone and is probably caused by a high Radon emanation in the fault zone.

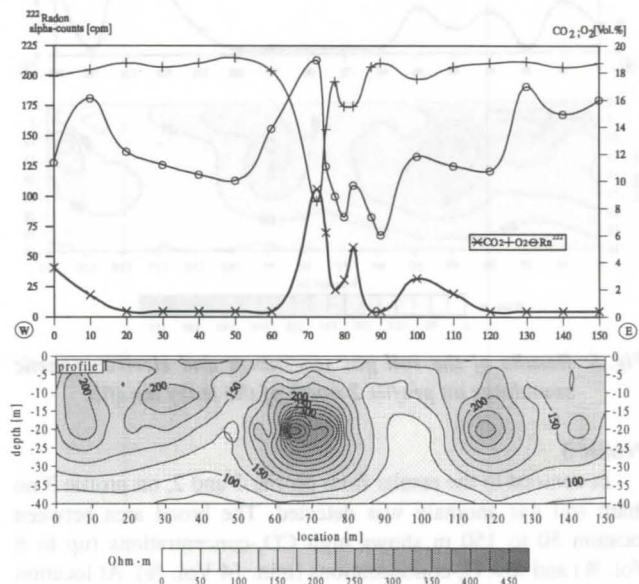

Fig. 4: Results of the soil gas screenings and electromagnetic soundings on profile 1 north of the leaky landfill.

The results of the electromagnetic soundings shows a broad zone below 35 meters and two areas with low apparent electrical resistivities at location 55 m and 110 m in 20-40 m depth (Fig. 4). The zone below 35 m depth refers to the groundwater of the karst aquifer. It seems, that the two anomalies corresponds to two separate, inclined extension fault zones. The very low resistivities (< 50 Ohm-m) in those zones possibly indicates saturated conditions (water, leachate) within the limestones. At location 55 m, this low resistivity zone reaches up to 15 meters below surface.

Profile 2

At location 115 to 135 m a significant CO_2 maxima in soil gas was detected. This maximum reached 12 Vol. % CO_2 in soil gas and corresponds clearly with the detected minimum of 10 Vol. % O_2 . The positive CO_2 and negative O_2 anomaly at this location refers to the already mentioned extension fault zone in the underground (Fig. 5).

The results of the ^{222}Rn investigations indicates also a main anomaly at location 130 m and two minor anomalies at location 20 m and 70 m. While the ^{222}Rn anomalies at location 20 and 70 m refer to loamy soil conditions, the main ^{222}Rn anomaly at location 130 indicates the extension fault zone (Fig. 5).

The results of the electromagnetic soundings on profile 2 showed a broad zone below 35 meters and one area with low apparent electrical resistivities at location 120 to 130 m. The zone below 35 m depth refers probably to Middle Triassic siltstones. It seems, that the anomaly at 130 m corresponds to the mentioned inclined extension fault zone. The very low resistivities (<100 Ohm-m) in these zones possibly refers to fissured

limestones, partly filled with either clay minerals or soil water. At location 130 m this low resistivity zone reaches up to the surface.

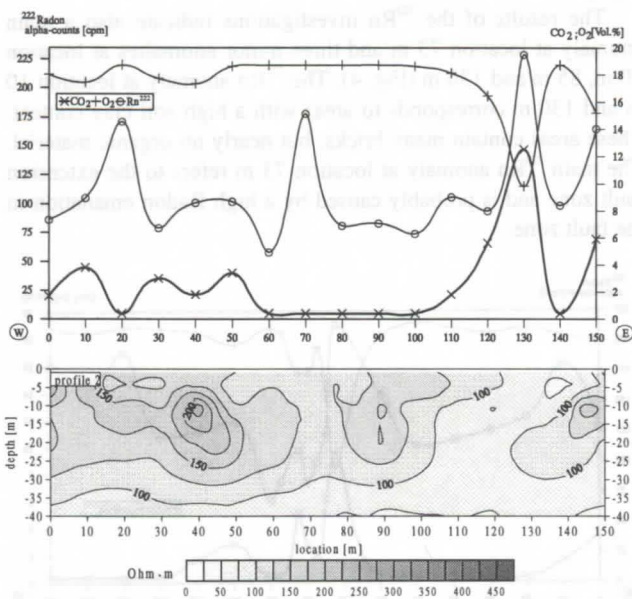

Fig. 5: Results of the soil gas screenings and electromagnetic soundings on profile 2 north of the leaky landfill.

Profile 3

In contrast to the results from profile 1 and 2, on profile 3 no sharp soil gas anomaly was detected. The broad area between location 50 to 150 m shows high CO_2 -concentrations (up to 6 Vol. %) and low O_2 -concentrations (min. 14 Vol. %). At location 80 m, 100 m and 120 m the soil CO_2 -concentration was low due to very high soil moisture contents (Fig. 6). The broad soil gas anomaly between 50 m and 150 probably refers to a broad fault zone, but it seems that the main contaminant transport will follow the earlier mentioned extension fault zone in north-eastern direction (Fig. 1).

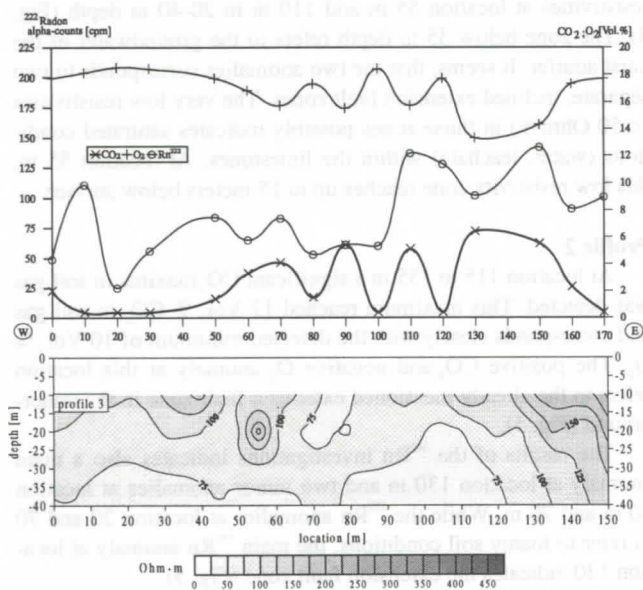

Fig. 6: Results of the soil gas screenings and electromagnetic soundings on profile 3 north of the leaky landfill.

The results of the ^{222}Rn investigations on profile 3 shows a broad anomaly between location 115 m to 150 m (Fig. 6). The ^{222}Rn anomaly at this location corresponds probably to a high permeable fault zone (Fig. 6).

The results of the electromagnetic soundings on profile 3 show a broad zone below 20 m with low apparent electrical resistivities. The low resistivities ($< 100 \text{ Ohm}\cdot\text{m}$) refer to fissured, partly water saturated limestones. The boundary between the Upper Muschelkalk limestones and the Middle Muschelkalk siltstones was not detectable in this profile (Fig. 6).

5. Conclusions

With the combined application of soil gas screenings and geophysical investigations, an extensional, inclined fault zone was detected in the karstified limestones forming the underground of the landfill Grötzingen. Leachate water leaks from the Grötzingen landfill into this fault zone and percolate down to the groundwater with low attenuation and dilution on discrete flow paths.

Acknowledgements: This paper is presented with the permission of the City of Karlsruhe who operate Grötzingen landfill. The authors would like to express their gratitude to B. Krauthausen, HYDROSOND for permission to publish the results and for funding the research work. The views expressed are those of the authors, and do not necessarily represent those of either of the above parties.

References

- AMUNDSON, R. & Y. WANG 1995. The relationship between the oxygen isotopic composition of soil CO_2 and water. in IAEA-SM-336/2, *proceedings of the International symposium on isotopes in water resources management*, 20-24 March. Vienna.
- BARBER, C., DAVIS, G.B., BRIEGEL, D. & WARD, J.K. 1990. Factors controlling the concentration of methane and other volatiles in groundwater and soil-gas around a waste site. *Journal of Contaminant Hydrology* 5: 155-169.
- DEYO, B.G., ROBBINS, G.A. & BINKHORST, G.K. 1993. Use of portable oxygen and carbon dioxide detectors to screen soil gas for subsurface gasoline contamination. *Ground Water* 31(4): 598-604.
- DÖRR, H. & MÜNNICH, K.O. 1990. ^{222}Rn flux and soil air concentration profiles in West-Germany. Soil ^{222}Rn as tracer for gas transport in the unsaturated soil zone. *Tellus* 42B: 20-28.
- EISWIRTH, M. 1995. Characterisation and simulation of contaminant transport from sewerages and landfills. (in German) *Schr. Angew. Geol. Karlsruhe* 38: 258. Karlsruhe.
- HENDRY, M.J., LAWRENCE, J.R., KIRKLAND, R. & ZANNYK, B.N. 1992. Microbial production of carbon dioxide in the unsaturated zone of a meso scale model, in KHARAKA (ed.) *Water-rock interaction*, Balk., 287-290.
- LEWIN, K., YOUNG, C.P. & BRADSHAW, K. 1992. Impact of waste disposal on the chalk and Sherwood sandstone aquifers. *manuscript International Symposium on Groundwater pollution at waste disposal sites: Detection, attenuation and remediation*. 20-22 March 1992: 16-32. Copenhagen.
- METCALFE, D.E. & FARQUHAR, G.J. 1987. Modelling gas migration through unsaturated soils from waste disposal sites. *Water, Air, and Soil Pollution* 32: 247-259.
- RIVETT, M.O. & CHERRY, J.A. 1991. The effectiveness of soil gas surveys in delineation of groundwater contamination: Controlled experiments at the Borden field site. *proceedings of the Conference on Petroleum Hydrocarbons and Organic Chemicals in Ground Water*, National Water Well Association, Houston. 20 - 22 November: 46-64. Texas.
- WASHINGTON, J.W. & ROSE, A.W. 1990. Regional and temporal relations of radon in soil gas temperature and moisture. *Geophys. Res. Lett.* 17(6): 829-832.

South Dobrogea karst vulnerability by assessment of some geophysical and geochemical parameters

by Radu Gaspar & I. Paunica

Institute of Physics and Nuclear Engineering, Bucharest, Romania

Abstract

The aquifer resources from South Dobrogea karst system are influenced by anthropogenic process (discharge, heat transfer) and pollution (nitrates, heavy metals, organic compounds).

Hydrochemical methods and neutron activation analysis were used to determine pollutant concentrations. Hydrodynamical parameters were determined by using environmental isotopes methods and artificial tracer techniques.

Using lumped parameter models of the groundwater dynamics from isotope and artificial tracer data, some parameters of karst vulnerability to pollution were assessed.

Résumé

Les ressources aquifères du système karstique de Dobrogea du sud sont influencées par des processus anthropogènes (déversements, transfert de chaleur) et pollution (nitrates, métaux lourds, composés organiques etc.).

Les méthodes hydrochimiques et l'analyse par activation neutronique, ont été utilisées pour la détermination de la concentration des polluants. Les paramètres hydrodynamiques ont été déterminés à l'aide des isotopes de l'environnement et des techniques utilisant traceurs artificiels.

En utilisant les données obtenues avec traceurs et modèles d'écoulement adéquats on a pu évaluer la vulnérabilité des eaux karstiques.

1. Introduction

Industrial, agricultural and other human activities have had and continues to have a significant impact on groundwater in most countries, especially in Eastern and Central Europe and in many developing countries.

The South Dobrogea karst has a special hydrogeological significance for Romania, therefore it has been and still is the object of the interest of the administrative factors as well as of the researchers. In order to qualify survey of the karst aquifers, the main reservoir for drinking water supply of the spa and littoral cities, starting with 1990 a regional monitoring system has been constituted, with the Barremian-Jurassic and Sarmatian aquifers as main objectives.

To determine the karst vulnerability and the immigration potential of pollutants important studies has been performed. Hydrochemical methods and neutron activation analyses were used to determine pollutant concentrations. Hydrochemical and hydrogeological parameters were determined using environmental isotopes methods and artificial tracer techniques.

2. Regional hydrogeologic information

Regional information were collected in order to identify the hydrogeologic subsystems which can be affected by pollution (e.g. in case of an accidental release either directly or indirectly through surface water). The information collected includes: climatological data, major hydrogeologic units, water-bearing characteristics of the units, recharge and discharge relationships and data on surface hydrology. Data on the type and stratigraphic distribution of the various geological formations were collected in order to characterize the regional system and its relationship with the local hydrogeologic units. This information was supplemented by data from previous exploratory work in the region. The hydrogeological subsystem from South Dobrogea consists of many aquifers in connections between them located in Paleozoic, Jurassic, Cretaceous, Sarmatian and Quaternary formations. The Paleozoic deposits has a big nonuniformity and a hydraulic conductivity between 0.01-0.15 m/d, some boreholes water having a temperature between 23.5°C and 27°C.

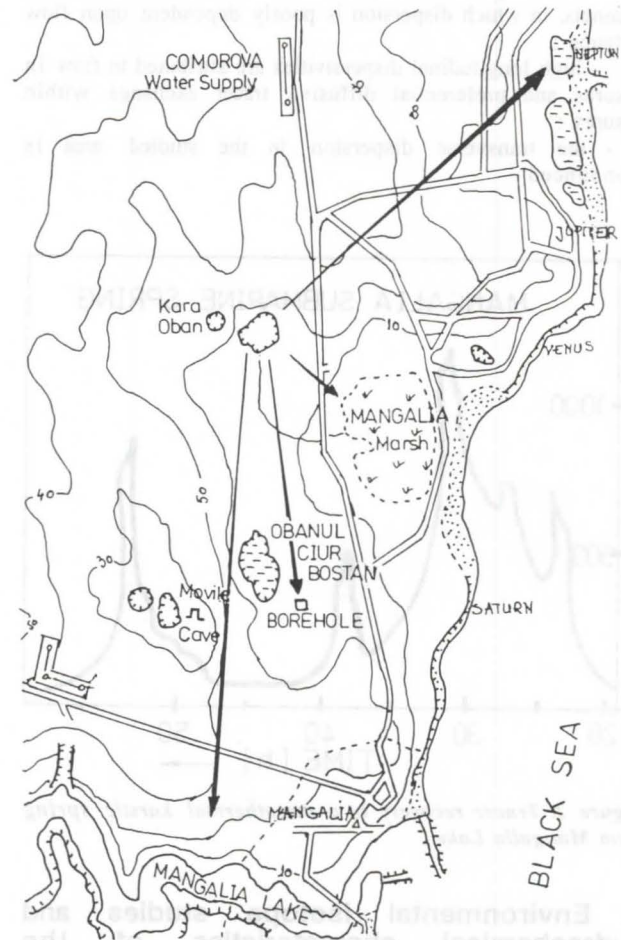

Figure 1. Hydraulic connections determined using radioactive and activable tracers in South Dobrogea karst system.

The Jurassic is formed by fissured limestones and is characterized by artesian sulfurous geothermal waters. The Barremian-Jurassic aquifer is the main aquifer and the main research objective of the South Dobrogea. The great extent of the natural recharge area of this Barremian-Jurassic aquifer is outside the national boundaries and cannot be directly surveyed. Between the Eocene, Cretaceous and Jurassic there is not continuous impermeable horizons and make a great complex aquifer with sulphide bearing waters. The transmissivities of the shallow aquifer varies between 50 and 2000 m²/d. The transmissivities of the deep aquifer vary between 200 and 150.000 m²/d. In the schematic representation of the groundwater flow model in the Barremian-Jurassic aquifer, (TENU et al, 1987) the flow direction is from SW to NE. In the karst subsystem from Mangalia including the Movile Cave the local flow direction is different. Thus, using artificial tracers (In-EDTA and NH₄⁸²Br) for labeling of the Kara Oban sinkhole, a divergent flow resulted (figure 1).

In this labeling which led to the establishment of a karstic diffuence part of the tracer was guided toward the Mangalia sulfurous lake. The tracer was recovered in three subaquatic mezothermal springs (figure 2).

From the types of concuraction-time curves, after the processing the experimental data (MALOSZEWSKI & ZUBER, 1984) resulted:

- low longitudinal dispersivities are attributed to solution channels, in which dispersion is poorly dependent upon flow distance;
- high longitudinal dispersivities are attributed to flow in fissures and preferential diffusive tracer exchange within fissures;
- the transverse dispersion in the studied area is pronounced

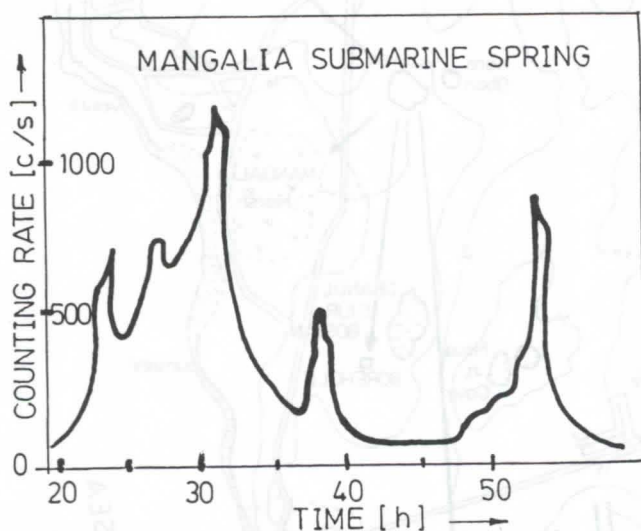

Figure 2. Tracer recovery in a mezothermal karstic spring from Mangalia Lake.

3. Environmental isotope studies and hydrochemical characteristics of the groundwater resources.

Groundwater studies during the last 8 years was performed in a monitoring network of the boreholes and surface waters. These studies, including environmental isotope (T, D, ¹⁸O) and hydrochemical and radioactivation analysis revealed the behaviour of shallow and deep aquifers.

Thus the T concentrations decrease 10-100 m below surface between 54 TU for Tatlageak lake and 5 TU for a deep borehole, in Paleozoic. (The average value in 1995 year for the Movile Cave was 32 TU). The stable isotope content, D and ¹⁸O, demonstrated the origin of shallow and groundwater. In the δ²H versus δ¹⁸O diagram (SARBU & POPA, 1991), points fall for fresh water on the "local meteoric water line". Instead for the geothermal water line, points fall below the local meteoric line.

For a synthetically spatial hydrochemical feature of different water types in their vertical succession, we have chosen the mean anionic composition. Thus, the variation of TDS values between surface waters and the Barremian-Jurassic aquifer varies from 700 mg/l to 638 mg/l, for the same interval, the change of the anion concentrations is from 150 to 96 mg/l for Cl⁻, from 139 to 43 mg/l for SO₄²⁻ and for HCO₃⁻, from 198 to 294 mg/l. (TENU & all, 1991). For sulfurous waters, the correlation between the variation of the TDS and H₂S concentrations (m/Kg)_{H₂O} with depth and temperature is presented in figure 3. The point represents the Movile Cave where a unique cave ecosystem is developed.

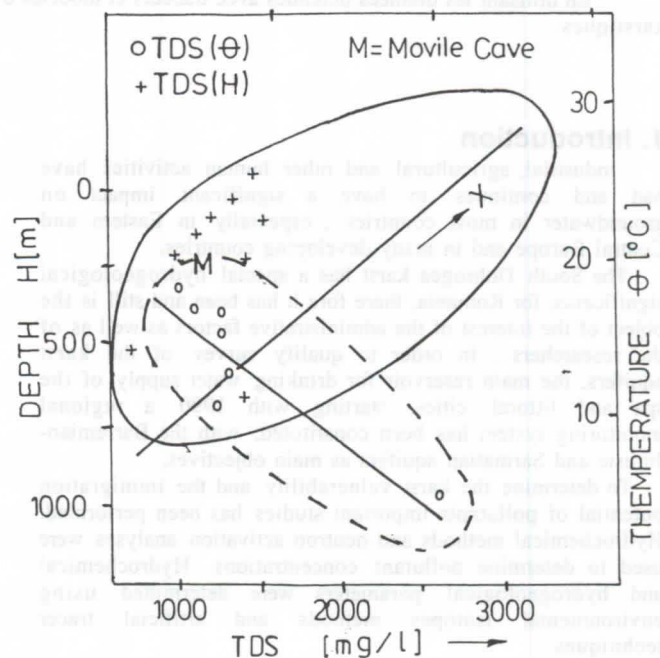

Figure 3. Correlation clouds between temperature and depth for South Dobrogea underground waters.

4. Polluting sources and pollutants nature.

The aquifer resources from Southern Dobrogea karst system are influenced by anthropogenic processes (discharge, heat transfer) and pollution (nitrates, heavy metals, organic compounds). The higher vulnerability to pollution of the shallow aquifer consists not only in its recharge from irrigation system but also in the leakage and the seepage loss of industrial estates and factories (ZAMFIRESCU & all, 1994). Specific pollution indicators are measured: NH₄⁺, PO₄³⁻, NO₂⁻, NO₃⁻, Fe²⁺. Toxic components as organo-chlorinated pesticides, herbicides, hydrogenated hydrocarbons have been determined. In surface waters (Tatlageak brook), Mn⁺⁺, Cd⁺⁺ and Pb⁺⁺ were also determined. (see table 1).

In the same time, a gradual increase towards the South of the NO₃⁻ content was observed.

	TDS (mg/l)	Mn ⁺⁺ (µg/l)	Cd ⁺⁺ (µg/l)	Pb ⁺⁺ (µg/l)	θ(°C)
Tatlageak brook	793	282	7	100	
Borehole 4073	1188	14	5.8	38	25
Mangalia lake spring	4480	24	9	10	
Albesti brook	1583	178	2	UDL	
Borehole 4074	1132	30	12	28	22.8
Litoral spring Venus	1282	27	12	5	
Factory borehole	1229	7	7	30	23
Movile Cave	949	UDL	UDL	UDL	19

Table 1. Some physico-chemical characteristics (UDL= under detection limit).

References

- GASPAR,E. & IORASEANU , 1987 : Natural and artificial tracers in the study of the hydrodynamics of karst. Theoretical and Applied Karstology 3 ; 31-107.
- SARBU,S.N.&R.POPA,1992: A unique chemical antropogenic based cave ecosystem. The natural history of biospeology. Ed.Ana Isabel Comach , Madrid.
- TENU, A.F.DAVIDESCU, S.SIMONAS, L.EICHINGHER , B.BERTLEFF, W.MICHEL, E.SECARA, Z.CARADIMA & N.PITU. 1994. Assessment of the pollution impact on the Groundwater Quality in South Dobrogea, Proc. Symp. Impact of Industrial Activities on Groundwater, Constanza, 557.
- ZAMFIRESCU,F. , V.MOLDOVEANU , C.DINU , N.PITU , M.ALBU , A.DANCHIV & H.NASH , 1994 : Vulnerability to pollution of karst aquifer system in Southern Dobrogea.Proc.Symp.Impact of Industrial Activities on Groundwater , Constanza.591 .

Geophysical methods as a tool for speleological and geotechnical investigation in karst Maira, Plateau de Bure (JU), Switzerland

Meier Edi¹; Huggenberger Peter²; Stiefelbogen Wilhelm³; Müller Imre³; Christe Romain⁴

¹ Edi Meier + Partner AG, Hard 4, CH-8408 Winterthur, 100777.3453@compuserve.com

² EAWAG, CH-8600 Dübendorf, Huggenberger@EAWAG.CH

³ Université de Neuchâtel, Centre d'Hydrogéologie, CH-2007 Neuchâtel

⁴ MFR Géologie-Géotechnique SA, Rue de Chauv 9, CH-2800 Delémont

Abstract

Ground penetrating radar (GPR) profiles have been recorded on the karst plateau of Bure in the NW part of Switzerland. The NE part of this plateau is drained by a subsurface river. The axis of the planned highway N16 crosses the karst plateau at the test-site near the locality of Maira. At this site, the water level is located about 50 m below the surface. Speleologists early on recognized chimney systems several meters in diameter which come up near to the surface. These chimneys potentially present a major source of difficulty in the highway construction, e.g. for foundations, blocking of tunnelling machines etc. After profile-mapping the area every 5 m with continuously measured Very Low Frequency Electromagnetics (VLF-EM) method, a series of GPR measurements followed in summer 1995.

The GPR experiments performed with sets of 50 MHz and 100 MHz antennae showed reflectors up to a depth of about 25 meters in the limestone sequences. The soil thickness in this case was in the order of decimeters. In areas of increasing clay-rich soil thickness, the penetration of the GPR waves is reduced to several meters. From both these methods, chimneys and the orientation of the main geologic structures can clearly be identified.

A comparison of the results of the VLF-EM and GPR measurements allows us to establish some general statements on the suitability of the two methods to address the questions mentioned above.

1. Introduction - regional setting

The Ajoie plateau is situated north of the external part of the Jura arc, near the French-Swiss border. The backbone of the plateau is formed by an essentially calcareous, subhorizontal Upper Jurassic series (approximately 300 m thick). It is cut by north-south trending, subvertical faults, whose throw gives the plateau a "piano key" structure. Karstification of the limestone is well-developed:

- the surface of the limestones is locally relatively karstified (epikarst) and covered by a soil which is generally relatively thin (< 0.5 m), but in some places, up to 15 m thick,

- several active caves are known, of these the largest is the Milandre cave, which is located just below the Swiss N16 highway project.

The Milandre cave network is situated 40 and 50 m beneath ground level. Speleological exploration has recently mapped chimneys going up to only a few meters below the surface. Some of these chimneys are located directly beneath the projected highway, especially in the area of the southern entrance of the tunnel.

These karstified features occur either as voids or as caves filled with an admixture of limestone blocks and fine sediments. These zones present collapse and settlement risks associated with the construction of the highway.

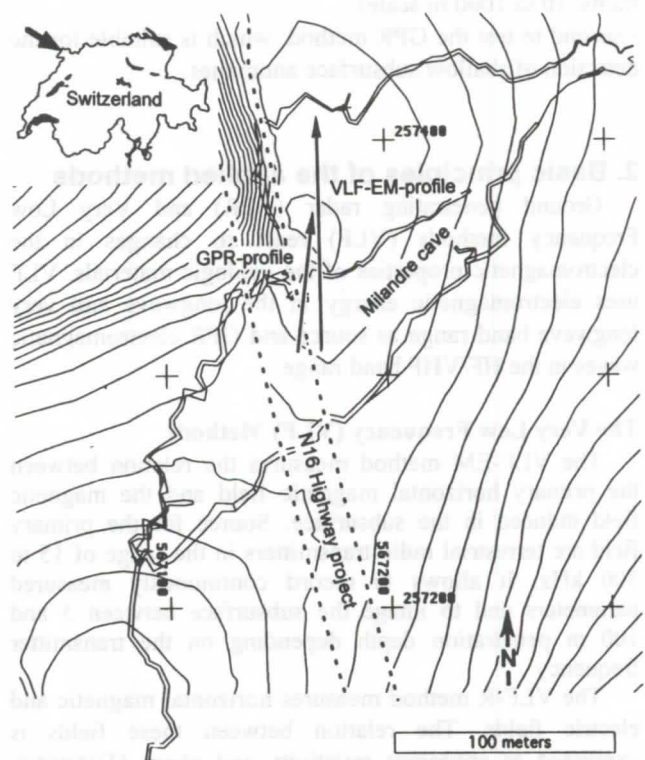

Figure 1: Location of the test-site at Maira

The following problem is to be solved by the engineers: karst phenomena such as those mapped by the speleologists (figure 2) probably occur elsewhere under the projected highway but near the surface voids can not be detected.

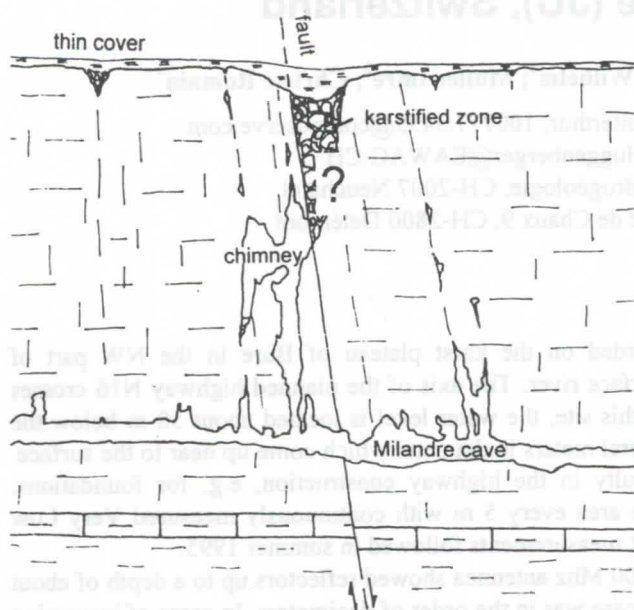

Figure 2: Cross-section of the Milandre cave network

The aim of this investigation with geophysical methods was to see how well karst phenomena may be detected by using a combination of different geophysical methods: - first a survey with VLF- methods (TURBERG, 1993; MÜLLER et al., 1995) has been carried out to define large scale geological structures (local regional geological faults: 10 to 1000 m scale) - second to test the GPR method, which is suitable for the detection of shallow subsurface anomalies.

2. Basic principles of the applied methods

Ground penetrating radar (GPR) and Very Low Frequency methods (VLF) react to changes in the electromagnetic properties of the geologic materials. VLF uses electromagnetic energy in the longwave and very longwave band range as source and GPR electromagnetic waves in the HF/VHF band range.

The Very Low Frequency (VLF) Methods

The VLF-EM method measures the relation between the primary horizontal magnetic field and the magnetic field induced in the subsurface. Source for the primary field are terrestrial radio transmitters in the range of 15 to 300 kHz. It allows to record continuously measured parameters and to image the subsurface between 5 and 100 m penetration depth depending on the transmitter frequency.

The VLF-R method measures horizontal magnetic and electric fields. The relation between these fields is expressed as apparent resistivity and phase (TURBERG, 1993). This method allows us to calibrate the VLF-EM measurements and to estimate the penetration depth of GPR.

The advantage of the VLF-EM is greater sensitivity to vertical structures and the possibility to record the data continuously. This results in higher lateral data resolution. Extreme points and the position of the strongest derivative give hints where to search for geological anomalies. The relation between the measured fields are complex numbers. The imaginary part is called „out of phase“ component and used for interpretation because it is more stable than the real component.

The Ground Penetrating Radar (GPR) method

The GPR system consists of a pair of separated transmitter and a receiver antennae. The transmitter antenna emits short electromagnetic pulses of a certain central frequency and bandwidth. Reflections occur when the electromagnetic waves meet boundaries between geological units of contrasting dielectric properties. The reflected waves are recorded by the receiver antenna. The elapsed time between the transmitted pulse and the received echo and the propagation velocities of the electromagnetic waves allow to estimate the depth of the reflections.

3. Results of the VLF-EM Survey

The three-dimensional representation of the data measured at Maira illustrates the VLF-EM method. The profiles in figure 3 have been chosen to compare the VLF-EM data with the GPR data and the position of the cave. Several frequencies were measured in NS profiles. Two transmitters in EW direction (18.3 and 162 kHz) are presented here. This configuration is sensitive to EW anomalies. Since this sensitivity depends on the transmitter direction, NS anomalies should be mapped by transmitters in NS direction and profiles in EW direction.

In the figure the position corresponds to the first rising ramp of the 18.3 kHz curve at a position with maximal first derivative. This correlation is possible in each of the measured profiles between $x = 567'100$ m and $x = 567'170$ m. Even some minor variations can be seen in parallel profiles. The effects observed for 162 kHz are much weaker. Its penetration depth is smaller than for 18.3 kHz because higher frequency results in better resolution but smaller penetration depth.

From the speleological investigations we know the location of the cave at $y = 257'342$ m to $y = 257'345$ m. In the 18.3 kHz curve we find a strong derivative at this point. This indicates a geological anomaly like a fault. A strong derivative can also be found in the 162 kHz curve, but at $y = 257'355$ m. We can not deduce the presence of a cave, but we have evidence for a north-south dipping fault.

4. Results of the GPR Survey

Evaluation of the suitability of the GPR method and optimization of the acquisition parameters

For planning the GPR Survey a model calculation was performed. Based on earlier VLF-R Surveys (TURBERG, 1993) the apparent resistivities and the lithologies of the geological formation at the test-site were known. With this prior information and the expected size and shape of the geologic inhomogeneities, we evaluated the optimum

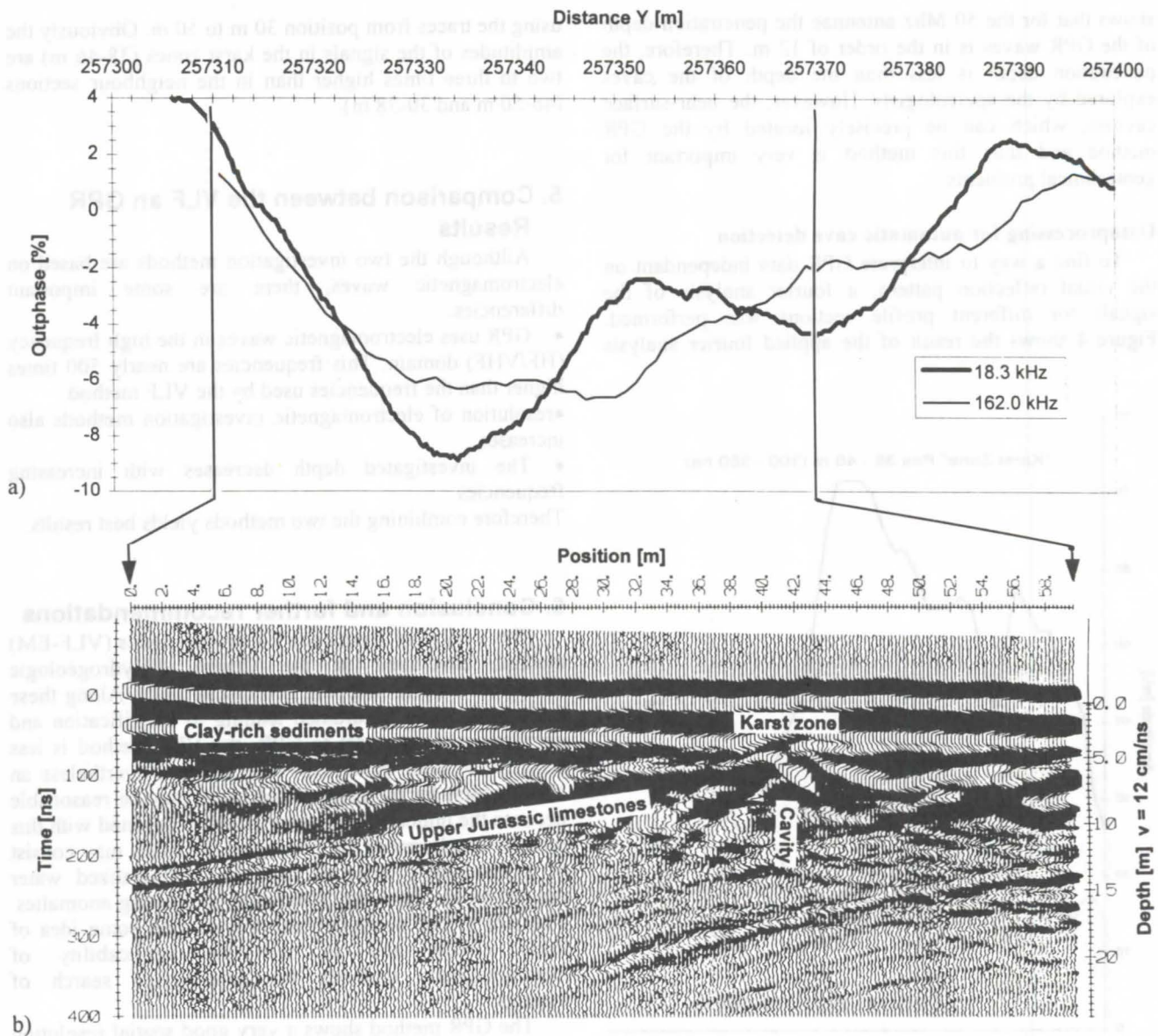

Figure 3: a) VLF-EM data recorded at Maira
 b) GPR data recorded at the same test-site as above.

antennae frequency and the acquisition parameters by using the radar range analysis proposed by ANNAN and DAVIS, 1977. As a result of these calculations for the 50 MHz antennae the maximum penetration depth was expected to be on the order of 26 m in high resistance areas and 6 m in areas of low resistance (assumptions: no soil cover, air-filled cavity, height 15 cm, diameter 80 cm).

Field Measurements

Seven profiles were recorded across the caves known from the previous speleological investigations. We recorded a radar trace every 25 cm. We used the 100 MHz antennae for two of the GPR profiles and the 50 MHz antennae for the other five sections. To determine the velocity distribution, a set of CMP-data (common mid point, ROBINSON, 1989; MEIER & HUGGENBERGER, 1992) was collected. To minimize the damage on the cultivated

land, the long antennae axis were oriented parallel to the profile trace.

Presentation of the data

GPR-data are presented in two-way-traveltime distance diagrams. The traces are displayed in the wiggle mode. For the conversion of traveltime to depth a mean propagation velocity of 12 cm/ns was assumed.

Interpretation

A continuous reflection ascends from a depth of 10 m at position 14 m to a depth of 5 m at position 40 m. Between 40 m and 42 m the reflections are discontinuous and dipping in both profile directions. A clear hyperbolic shape at 41 m is interpreted as a cavity or a karst deposit at the depth of about 7 m. The continuous reflections represent „undisturbed“ Upper Jurassic series. Figure 3b

shows that for the 50 Mhz antennae the penetration depth of the GPR waves is in the order of 12 m. Therefore, the penetration depth is less than the depth of the caves explored by the speleologists. However, the near-surface cavities, which can be precisely located by the GPR method and thus this method is very important for geotechnical problems.

Dataprocessing for automatic cave detection

To find a way to interpret GPR data independant on the visual reflection pattern, a fourier analysis of the signals for different profile sections was performed. Figure 4 shows the result of the applied fourier analysis

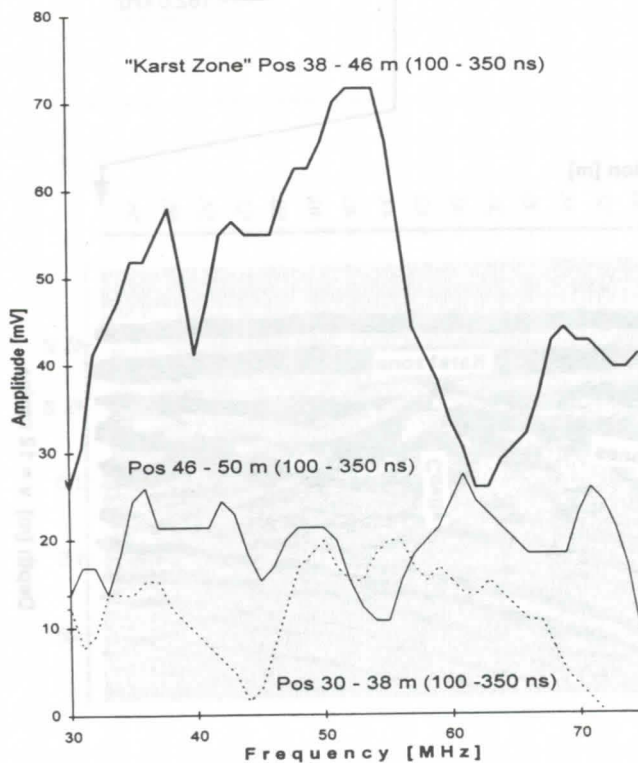

Figure 4: Fourier analysis of the data shown in figure 3b

References:

- ANNAN, A. P., DAVIS, J.L. (1977): Radar range analysis for geological materials, Report of activities, Part B; Geol. Surv. Can., Paper 77-1B
- DAVIS, J.L., ANNAN, A. P. (1989): Ground -penetrating radar for high resolution mapping of soil and rock stratigraphy. Geophysical Prospecting 37, 531-551
- MEIER, E., HUGGENBERGER, P. (1992): Georadar zur Kartierung der obersten 10 bis 20 Meter des Untergrundes. Wasser, Energie, Luft, 5/6, Verbandszeitung Schweizerischer Wasserwirtschaftsverband, Baden (Schweiz), 111-113
- MÜLLER, I., STIEFELHAGEN, W. and INTCHI, A.R., (1995): Réflexions sur les résultats obtenus par l'enregistrement en continues des paramètres géophysiques, électromagnétiques (VLF-EM) et magnétiques, pour l'exploration hydrogéologique des aquifères karstiques (Grotte de Milandre, Jura, Suisse). Bulletin de la Société neuchâtoise de sciences naturelles.
- ROBINSON, E. A. (1989): Seismic velocity analysis and the convolutional model. Int. Human Resources Dev. Corp. Boston, 290
- TURBERG, P. (1993): Apport de la cartographie radiomagnetotellurique à l'hydrogéologie des milieux fracturés. Thesis, CHYN Neuchâtel, Switzerland, 132 p.

using the traces from position 30 m to 50 m. Obviously the amplitudes of the signals in the karst zones (38-46 m) are two to three times higher than in the neighbour sections (46-50 m and 30-38 m).

5. Comparison between the VLF and GPR

Results

Although the two investigation methods are based on electromagnetic waves, there are some important differences.

- GPR uses electromagnetic waves in the high frequency (HF/VHF) domain. This frequencies are nearly 500 times higher than the frequencies used by the VLF method.
- resolution of electromagnetic investigation methods also increases.
- The investigated depth decreases with increasing frequencies.

Therefore combining the two methods yields best results.

6. Conclusion and further recommendations

The Very Low Frequency Electromagnetics (VLF-EM) method developed at the Centre d'Hydrogéologie Neuchâtel enables mapping geological faults. Along these faults water may be drained leading to karstification and excavations. In contrast to GPR, the VLF method is less sensitive to poor conductors like caves. Nevertheless an investigation for the presence of caves may be reasonable because the underlying geology is easily detected with this method. Furthermore the coating of the caves may consist of a conducting material like clay. Mineralized water drained by the cave may also cause conducting anomalies. The aim of our measurements was to gain some idea of these effects and to test the applicability of electromagnetic methods for near-surface search of cavities.

The GPR method shows a very good spatial resolution of the detected anomalies. This allows to recognize shallow karstified zones. In non-destructive investigations the GPR method has become a common method. We suggest that amplitude analysis might be a useful tool helping to interpret GPR data in karst areas.

Contamination of carbonate aquifer and evidence of karst effects in Israel

by Abraham J. Melloul and Stuart Wollman
Israel Water Commission, the Hydrological Service
P.O. Box 6381, IL-91063 Jerusalem, ISRAEL

Abstract

Ground water contamination may be enhanced by different contaminants which percolate to the water table from ground surface land-usages. In arid and semi arid areas, as in Israel, wetting/drying cycles of ground water recharges can augment the fissuration and cracking processes which increase hydraulic conductivity in soil and the vadose zone. In carbonate aquifers, this leads to the development of karst formations, leading to preferential channels with heightened infiltration rates of the pollutants to the aquifer. The objective of this study is to determine if there is some relationship between enhanced ground water contamination, and karstic development in a calcareous aquifer, located in an arid/semi-arid region. In the Western Galilee, pollution arrived in the ground water from a sewage pond located on calcareous rock, sited about 2000m upstream. The fingerprint indicator which characterizes this pollution was the sudden appearance of *E. Coli* bacteria. The second case involves the calcareous aquifer near Jerusalem. Here, ground water contamination is characterized by relatively high turbidity levels in the course of the initial day of abstraction from a pumping well. This, points toward the accumulation of dusty material in preferential channels over the winter in low pumpage period. On a regional scale, the behavior of the mountain Yarkon Taninim calcareous aquifer, subsequent to the unusually high rainfall year of 1991/92 is described. A sharp rise in water levels combined with an unexpected increase in ground water salinity is explained by karstic phenomena development mostly in the upper portion of the aquifer. The existence of karst as a major factor enhancing groundwater contamination should be considered for the use of management and operational models of the aquifer.

1. Background

This paper aims to illustrate and analyse the relationship between aquifer karstification and enhanced ground water contamination of a carbonate aquifer. The study will also focus on the arrival of pollutants from the ground surface to these aquifers vis-a-vis the ecological conditions affecting its management, and change in climate in these arid/semi-arid areas. This is shown by the analysis of chemical parameter behavior from the mountain carbonate Yarkon Taninim (YT) and Western Galilee (WG) aquifers (Hydrologic Report, 1996). The Yarkon Taninim aquifer represents one of the major sources of ground water exploitation in Israel. It is bounded in the west by the sea coast and on the east by the Judaeen and Samaria Mountains (figure 1). This basin is recharged by precipitation over the permeable limestone rocks of the Judaeen-Samaritan mountain ridge. The Western Galilee carbonate aquifer is a relatively small basin in comparison to the YT aquifer (figure 1). It is replenished from precipitation over the limestone outcrops aquifer which are mostly Cenomanian. Three case studies are presented. The first case relates to a disposal pond and a well located down gradient, in the Kefar Yassif area of the western Galilee. The presence of *E. Coli* (*Escherichia coli*) indicates the presence of bacterial pollutants (RCWQC, 1972) in carbonate aquifer ground water. A second case deals with the appearance of high turbidity values during the first activation of wells in a carbonate aquifer located in the vicinity of Jerusalem. The third case analyses the regional response of the YT carbonate aquifer to a climate change (the sharp appearance of a severe winter period). Data are mostly from the 1996 Hydrologic report and internal reports.

2. Results and discussion

Figure 2 deals with ground water contamination by *E. Coli* and *E. Coli faecali* bacteria in the Kefar Yassif well in the WG aquifer. This well is located 2 km westward and downgradient of the domestic sewage disposal pond of Yarka. Both facilities are sited in dolomite rocks characterised by their cavities and other karstic characteristic. The disposal pond used for domestic sewage, was active until 1990. It was built in 1984 without any good protective lining on its bottom. The K Yasif well became contaminated by *E. Coli* bacteria identified after a period of only one year after the date of the beginning of operation of the Yarka effluent reservoir. Analysis of this case indicates that conditions encouraging the pollution of the well were: (1) the source of pollution was located upgradient of the ground water flow direction relative to the well; (2) the anthropogenic pollutant source, in this case the Yarka effluent reservoir was not insulated from the aquifer rock below which has high transmissivity flow channels; and (3) the flow path does not absorb the microbiological populations nor the various toxics, and does not neutralize in any other way its detrimental influence on the contamination of the water. Thus, it is evident that the time duration of the pollutant in the aquifer seems to be very short (around 10m/day).

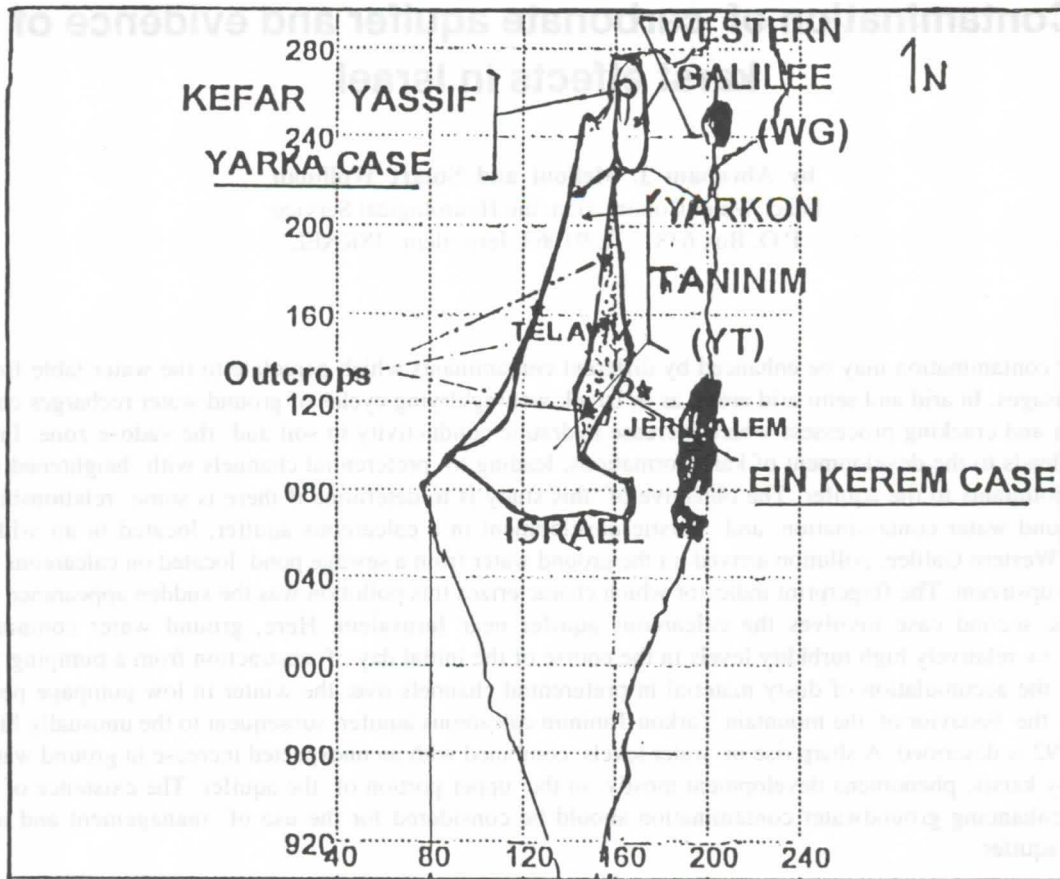

Figure 1: Location map of Israel: aquifers and local case studies

The second case presented on Figure 3, deals with ground water contamination by sediments in the Ein Kerem well No. 6 in the YT aquifer in the vicinity of Jerusalem. In this case, the measurements for a short period of time indicate high turbidity that appeared in the initial stage of well abstraction. Analyses indicate that the turbidity is due to clay mixed with coarse and fine granular quartz. One supposition is that the turbidity is caused by southerly winds blowing across desert areas, for a few days each year. During the dry seasons, these fine materials are deposited and accumulated in cavities and channels, but after the rainy seasons they are conveyed in the carbonate ground water aquifer through local karstic systems. Another source of this kind of fine material may also arrive with percolation from the sewage water rich in fine material which may be found in the subsurface (Goldenberg et al., 1993).

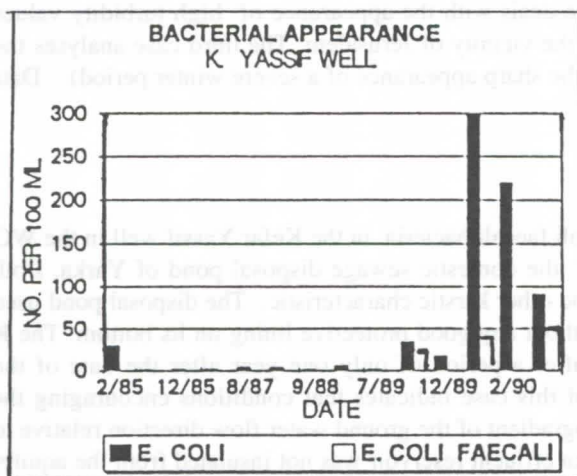

Figure 2 : E. Coli changes in the Kefar Yassif1 well

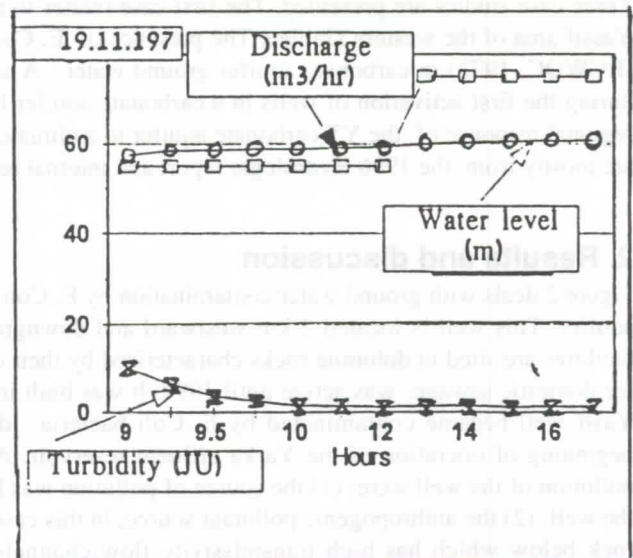

Figure 3 : Turbidity changes function of discharge and ground water levels in Ein Kerem6 Well

The third case study deals with the extremely high precipitation in the winter of 1991/92, and its regional impact on the groundwater quality of the mountain YT aquifer. This winter resulted in a mean annual average ground water level that was about twice the long term mean. Then, water levels for the aquifer returned to their historical level as in 1950's. Conversely, chloride levels continued to increase in most part of the aquifers, and their rate of increase reached two or more times the normal year value (around 1.5 mg Cl/l per year) as shown in figure 4.

3. Conclusion

The local and the large scale effects in the YT aquifer studies give us an indication about the large aquifer recharge and the high infiltration rate values. The results seem to be linked with karst phenomena which enable contaminants to be trapped and accumulated during the dry season in various cavities and channels in the vadose zone, and later released to ground water mainly after a period of severe rain, or due to sewage or effluent leakage.

One explanation of this highly developed Karst effect is the geological structure, with karst more developed in the upper (anticline) part of the Cenomanian carbonate rocks in Israel (Mendel, 1972). In such arid semi-arid areas, the change in climate and the wetting/drying cycles of ground water recharges can augment the fissuration and cracking processes in the subsurface which increase hydraulic conductivity in soil and the vadose zone. This phenomena activate groundwater circulations and karst effects, and enhance groundwater contamination in areas where there are pollutant sources.

Due to the increase in population, urbanization, density of wells, and high concentrations of anthropogenic activities that may be present in these areas, danger of contamination can occur due to the high rate of infiltration of water with pollutants and even other toxic materials arriving from replenishment areas with untreated or partially treated sewage. Thus, the main operational conclusions for preventing the deterioration of ground water quality in such aquifers are to prevent the entrance of undesirable materials to the aquifer system by diminishing pollutant sources by adequate management of the aquifer, good treatment of waste water, and by augmenting dilution with good quality water.

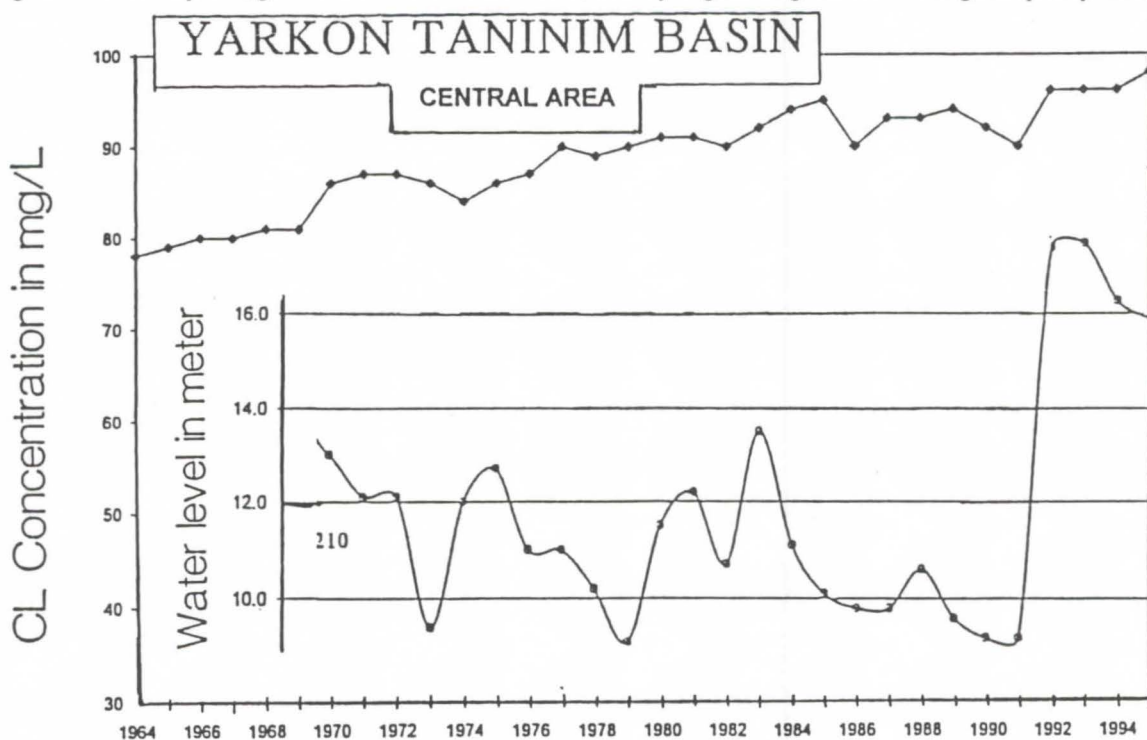

Figure 4: Ground water changes and Chloride changes in the central area of the Yarkon Taninim aquifer

References

- EPA. 1972. Water Quality Criteria 1972. Report of the Committee on Water Quality Criteria 1972 Washington DC., 57-58.
- GOLDENBERG L.C., MELLOUL A. AND S. ELHANANI. 1993. Mechanism of ground water pollution in the western montanuous Judea-Samaria aquifer. Assessment and Simulation: In Judea-Samaria Research book. 20-25pp, (in Hebrew)
- HYROLOGICAL SERVICE REPORT. 1996. Evolution of ground water resources of Israel up to autumn 1995. ISSN_ 0793-1093, Jerusalem, 210 pp, (in Hebrew).
- MELLOUL, A. AND L.C. GOLDENBERG. 1993. The rainy winter of 1991/92 and its influence on the ground water quality in the Coastal plain aquifer of Israel, Water and Irrigation Journal, 319: 51-54. (in Hebrew).
- MENDEL, S. 1966. A conceptual model of karstic erosion by ground water. Reprint of Bulletin of the I.A.S.H, XI^c N^o 1 1966, 5-7.

Nitrification des eaux rejetées par la STEP de La Chaux-de-Fonds - Suisse - lors de leur passage dans le système karstique de la Ronde

Par Paul-Etienne Montandon, Stéphane Gogniat, Pierre Rognon¹ et Jean-Jacques Miserez

Service de l'Hygiène et de l'Environnement, Serre 23, 2300 La Chaux-de-Fonds, Suisse

Résumé

Les eaux issues de la station d'épuration des eaux usées (STEP) de la ville de La Chaux-de-Fonds (40'000 habitants), Suisse se déversent dans la combe du Valanvron, formant le ruisseau de la Ronde. Ces eaux s'infiltrent progressivement dans un système karstique pour disparaître totalement après un parcours aérien de 1500m. Les résurgences de ce système se situent au niveau du Doubs.

Les recherches effectuées montrent que le parcours souterrain de la Ronde se déroule essentiellement en milieu à écoulement libre et que le système karstique présente de réelles capacités d'auto-épuration, en particulier la nitrification de l'ammonium présent dans les effluents de la STEP. A partir de l'analyse d'un élément conservatif (chlorures), on a pu montrer que le taux de dilution des eaux de la Ronde entre la STEP et les résurgences varie entre 3 et 6 selon les conditions pluviométriques. L'analyse des flux massiques des éléments rejetés par la STEP montre que, pendant la période de mesures, le 86 % de l'ammonium disparaissant dans le système karstique est oxydé en nitrate. Enfin, l'ammonium, provenant de la STEP et parvenant au Doubs après passage dans le système karstique, représente le 50 % des apports de cet élément sur le tronçon considéré ou encore le 35 % de la quantité totale d'ammonium transportée par le Doubs en aval de ce secteur.

Summary

Treated wastewaters coming from the sewage treatment plant (STP) of the city of La Chaux-de-Fonds (40'000 inhabitants), Switzerland, flow down the Valanvron valley where they become a small river that progressively infiltrates the karstic system and totally disappears after a course of 1500m. The resurgences of the system are located at the level of the Doubs river.

The present research shows that the underground course of the Ronde river essentially flows through an unsaturated zone and that the karstic system has real self purification capacity, namely nitrification of ammonium found in the STP effluents. By analyzing a conservative element (chlorides), we were able to estimate that the rate of dilution of the Ronde river between the STP and the resurgences varies from 3 to 6 in function of the level of precipitations. Analysis of the mass flow of pollutants rejected by the STP shows that 86 % of the ammonium, which disappears in the karstic system, is oxidized into nitrates during the period of measurements. Finally, we found that the ammonium coming from STP that reaches the Doubs river, after passing through the karstic system, represents the 50 % of the input of that compound over the considered section or 35 % of the total amount of ammonium carried by the Doubs river downstream from this area.

Introduction

En service depuis 1975, la STEP de La Chaux-de-Fonds (40'000 habitants) collecte toutes les eaux usées de la ville ainsi que les eaux pluviales du synclinal (24'600 m³/jour ou 285 l/s en valeur moyenne annuelle). L'épuration des eaux comprend un traitement mécanique, un traitement biologique par boues activées et une décantation finale. Du chlorure ferrique est ajouté à plusieurs étapes du traitement, notamment pour la déphosphatation. L'azote inorganique provenant de la biodégradation de la matière organique n'est pas nitrifié et est donc rejeté sous la forme d'ammonium.

Les effluents de la STEP empruntent le lit d'un ancien cours d'eau dans la combe du Valanvron où ils forment un ruisseau de faible débit appelé la Ronde, qui s'infiltré progressivement dans le sous-sol calcaire par plusieurs pertes diffuses pour disparaître totalement après un parcours aérien de 1'000 à 1'500 m en régime hydrique normal (figure).

Lors de son parcours souterrain, la Ronde rejoint le système d'écoulement karstique naturel. Après quoi, les eaux de la Ronde, gonflées et diluées par les eaux du système, ressortent par diverses résurgences au niveau du Doubs, dont les principales sont celles de la Verrerie et de la Rasse. Le temps de transit, qui varie en fonction des conditions pluviométriques, est de l'ordre de 3 à 7 jours. En dépit de la rapidité d'écoulement des eaux, ce système karstique présente des capacités intéressantes d'auto-épuration, en particulier l'oxydation en nitrates de l'ammonium rejeté avec les effluents de la STEP (Montandon et al. 1995). Lors de précipitations importantes, le trop plein des eaux, auquel s'ajoutent les eaux provenant d'écoulements périphériques, s'écoule dans la combe du Valanvron, passe par le Cul-des-Prés et rejoint le Doubs par l'étang de Biaufond.

Dans le présent travail, nous avons évalué les flux massiques des composés azotés inorganiques rejetés par la STEP et réapparaissant au niveau du Doubs. Il s'agissait d'établir la part de ce type de pollution dans le Doubs imputable aux rejets de la STEP.

¹ Adresse actuelle : Ecole polytechnique fédérale de Lausanne, département de génie rural, Suisse

Hydrogéologie

La région de la Chaux-de-Fonds - la Ronde, qui appartient au domaine du Jura plissé (Bourquin et al. 1946, Bourquin et al. 1968, Favre 1911), se situe en domaine karstique. La surface totale du bassin versant a été estimée à 44 km² (Montandon et al. 1995). Les calcaires plus ou moins fracturés sont karstifiés et donc susceptibles d'être le siège d'aquifères.

Le dogger est essentiellement composé de calcaires et marno-calcaires plus ou moins karstifiés, avec quelques niveaux peu perméables fonctionnant comme aquicludes locaux.

Tous les étages du Malm sont largement karstifiés. L'oxfordien et l'argovien inférieur (couches de Birmensdorf) jouent probablement un rôle sur les circulations profondes. L'argovien supérieur, qui est en continuité avec les calcaires du reste du Malm, constitue l'aquifère le plus important de la région.

Le niveau de base de ce système est le Doubs, qui coule dans le synclinal du Pissoux-les Praillats. On peut noter que les sources du Dogger se situent au-dessus de celles du Malm en raison du chevauchement de l'anticlinal des côtes du Doubs. Finalement, on relèvera qu'il est difficile de jauger les sources du Malm, voire

même impossible, car elles sont proches du Doubs (Rasse) ou arrivent directement dans le lit de la rivière (Verrerie).

Méthodes

Les prélèvements ainsi que les analyses des chlorures, de l'ammonium, des nitrites, et des nitrates ont été effectuées comme décrit précédemment (Montandon et al. 1995). Le carbone organique total (COT) a été dosé par infrarouge après minéralisation à chaud avec un appareil Dorman 190. Enfin, l'azote total a été mesuré par la méthode de Kjeldahl modifiée. L'azote organique est minéralisé à chaud et en milieu acide; l'ammonium est ensuite dosé par colorimétrie. Les valeurs données sous l'appellation "azote total" correspondent donc à l'ensemble de l'azote organique et de l'ammonium.

Résultats

Afin d'évaluer l'impact de la STEP sur son milieu récepteur, nous avons analysé le devenir des polluants rejetés par la STEP dans le système karstique. Nous avons mesuré les substances polluantes, qui entrent dans le système karstique, à la sortie de la STEP et celles, qui en ressortent, à la résurgence de la Rasse, qui a été considérée comme représentative de toutes les autres résurgences de la Ronde.

Périodes de mesure	Facteur de dilution dans l'aquifère ¹	STEP			La Rasse		
		Ammonium	Nitrites (mg N/l) ²	Nitrates	Ammonium	Nitrates (mg N/l)	Nitrates
18 au 26.06.1992 ³	NE ⁴	18,1 ± 2,3	0,06 ± 0,03	0,22 ± 0,14	1,46 ± 1	0,22 ± 0,16	7,4 ± 0,5
17 au 30.03.1993 ^{3,5}	2,8 - 3,0	16,7 ± 6,1	0,26 ± 0,18	0,41 ± 0,28	1,49 ± 0,46	0,024 ± 0,01	6,75 ± 0,98
04.05 au 11.05.1994 ^{6,7}	4,7 - 5,8	12,5 ± 7	0,14 ± 0,1	1,29 ± 0,86	0,24 ± 0,64	0,009 ± 0,01	2,64 ± 1,1
21.06 au 05.07.1994 ⁶	4,0 - 4,2	20,7 ± 4,4	0,27 ± 0,48	0,64 ± 0,86	1,27 ± 0,73	0,42 ± 0,39	5,42 ± 1,28
28.04 au 15.06.1995 ^{6,8}	2,8 - 3,0	17,2 ± 6,2	0,073 ± 0,048	1,17 ± 0,76	0,68 ± 0,71	0,019 ± 0,013	5,35 ± 1,28
08.11 au 06.12.1995 ⁹	2,8 - 3,0	17,9 ± 7,2	0,089 ± 0,083	0,572 ± 0,648	0,975 ± 1,34	0,015 ± 0,009	4,94 ± 1,51

Tableau 1 : Facteurs de dilution et valeurs moyennes des composés azotés inorganiques à la sortie de la STEP et à la Rasse

¹ Les valeurs données correspondent à celles calculées pour une concentration en chlorures de 5 mg/l et respectivement 10 mg/l dans les eaux de dilution

² Mg N/l = milligramme d'azote par litre

³ Analyse effectuée à partir d'un échantillon journalier moyen

⁴ NE : non effectué

⁵ Température et teneur en oxygène; Rasse : 9,2 ± 0,39 °C et 1,13 ± 0,24 mg d'oxygène/l; STEP : 10,7 ± 1°C et 4,9 ± 1,1 mg d'oxygène/l.

⁶ Analyse effectuée à partir d'échantillons prélevés sur une période de 4 heures

⁷ Température et teneur en oxygène du 6 au 26 avril; Rasse : 8,6 ± 0,3°C et 4,7 ± 0,5 mg d'oxygène/l; STEP : 8,5 ± 1°C et 5,5 ± 0,5 mg d'oxygène/l.

⁸ Température et teneur en oxygène; Rasse : 9,25 ± 0,15 °C et 4,65 mg d'oxygène/l; STEP : 11,35 ± 1,75°C et 6,9 ± 0,3 mg d'oxygène/l.

⁹ Analyse effectuée à partir d'échantillons prélevés sur une période de 4 heures (STEP) ou d'échantillons ponctuels prélevés chaque jour (Rasse).

Nitrification de l'ammonium et diminution de la teneur en COT

Dans un système karstique comme celui de la Ronde, on connaît le débit des effluents de la STEP, mais il est difficile de jauger les débits des résurgences, en raison de leur proximité avec le Doubs ou parce qu'elles se situent directement dans le lit de la rivière. On ne peut donc pas estimer si la diminution de la concentration mesurée d'un polluant dans le système provient d'une adsorption, d'une transformation ou simplement d'une dilution.

Nous avons précédemment montré l'utilisation d'un élément conservatif, les chlorures (Montandon et al. 1995), pour analyser la vitesse d'écoulement et le taux de dilution des effluents de la STEP dans le système karstique. Le tableau 1 présente les valeurs de ce taux calculé pour les différentes campagnes d'analyses ainsi que les valeurs de concentration des composés azotés inorganiques dans les effluents de la STEP et à la résurgence de la Rasse. On constate une diminution de la concentration d'ammonium et une augmentation de la teneur en nitrates, la forme oxydée des composés azotés inorganiques. Ces résultats indiquent que l'ammonium rejeté avec les effluents de la STEP est oxydé en nitrates au cours du trajet souterrain. Cette oxydation ne s'effectue pas aux dépens de l'oxygène dissous dans l'eau. En effet, les teneurs en oxygène à la Rasse se situent généralement à une valeur comprise entre 11 et 40 % de la saturation, alors qu'elles s'élèvent à 70 % de la saturation dans les effluents de la STEP (tableau 1). La quantité d'oxygène dissous correspondant à la différence entre les teneurs mesurées à la sortie de la STEP et à la Rasse n'est pas suffisante pour oxyder l'ammonium, étant entendu que la formation d'une mole de nitrates consomme 2 molécules d'oxygène moléculaire, ou 64 mg d'oxygène par milliéquivalent de nitrate formé. On peut conclure que le trajet souterrain de la Ronde se déroule essentiellement dans des conditions ventilées.

Estimations des débits

Afin d'aborder l'aspect quantitatif de cette étude, nous avons mené une campagne du 9 novembre au 6 décembre 1995, pendant laquelle nous avons analysé des échantillons prélevés dans le Doubs en amont de la Verrerie et dans le lac de Biaufond, ainsi qu'à la Rasse et à la sortie de la STEP. Le choix des sites de prélèvement dans le Doubs se justifie par le fait que l'on n'a pas trouvé d'apports significatifs provenant de la STEP en amont de la Verrerie et au delà du pont, qui est situé en amont du lac de Biaufond (figure; Gogniat, résultats non publiés).

Les débits d'eau aux sites de prélèvement ont été déterminés ou estimés comme décrit ci-dessous. Les débits qui sont mesurés à la sortie de la STEP, nous ont été communiqués par le responsable de l'exploitation; ils ont varié entre 0,15 et 0,92 m³/s avec une valeur journalière moyenne de 0,27 ± 0,19 m³/s. Pour l'amont de la Verrerie, le débit du Doubs correspond à la somme du débit de restitution du barrage et du débit turbiné à l'usine électrique du Châtelot, qui sont situés en amont du point de prélèvement, respectivement à 8 et à 4 km. Pendant la période de mesure, les débits, qui nous ont été fournis par le responsable de l'usine du Châtelot, ont varié entre 0,4 et 43 m³/s, avec une valeur moyenne de 13,6 ± 13,6 m³/s. Les fluctuations importantes des débits sont dues à l'exploitation de l'usine hydro-électrique. On estime que le débit est le même à la Verrerie qu'à l'usine du Châtelot, car il n'y a ni apport significatif ni perte d'eau sur le tronçon séparant ces points.

Le débit moyen pour la période considérée a été estimé à l'aval du lac de Biaufond par l'analyse des chlorures, en supposant que l'augmentation de la concentration des chlorures dans l'eau du Doubs, entre l'amont de la Verrerie et le lac de Biaufond, est due uniquement à l'apport de cet élément provenant de la STEP de La Chau-de-Fonds (Rognon, 1996). On admet que les apports en chlorures étrangers à la STEP sont peu importants. Le débit obtenu est de 18 m³/s, soit une valeur 1,3 fois plus élevée que le débit déterminé à l'amont de la Verrerie. Cette valeur est raisonnable, car Matthey (1986) a montré une augmentation du débit moyen du Doubs, pour le mois de novembre, de 1,5 entre le lac des Brenets, situé à environ 12 km en amont de la Verrerie, et la Combe des Sarrasins, qui se trouve à 4 km en aval du lac de Biaufond. D'autre part, les valeurs des précipitations pour le mois de novembre 1995 se situaient à une valeur proche de la moyenne, c'est-à-dire à 127 mm ou 111 % de la valeur moyenne.

Enfin, le débit moyen de la Rasse pour la période considérée a été évalué à 250 l/s, une valeur comprise entre le débit d'étiage (45 l/s) et le débit en hautes eaux (300 l/s; Matthey, 1990).

Détermination des flux massiques des composés azotés inorganiques, du COT et des chlorures

Les valeurs moyennes de concentration des paramètres analysés figurent dans le tableau 2 et les flux massiques calculés à partir de ces valeurs et des débits d'eau sont donnés dans le tableau 3. On peut déduire du flux massique des chlorures que le 33 % des eaux provenant de la STEP ressort à la Rasse pendant la période de mesures, le 67 % restant réapparaissant principalement à la Verrerie et probablement par des apports diffus directement dans le Doubs (Gogniat, résultats non publiés). On constate encore qu'en moyenne 430 kg d'ammonium ont été déversés quotidiennement dans le système karstique et que seuls 19 kg réapparaissent à la Rasse; compte tenu de la proportion des eaux de la STEP parvenant au Doubs par la Rasse, on peut calculer les apports totaux en ammonium arrivant au Doubs à 58 kg/j (tableau 4), soit 13 % des quantités déversées par la STEP.

Par contre, le flux massique des nitrates augmente fortement de la STEP à la Rasse (tableau 3). La comparaison des flux massiques de l'ammonium et des nitrates montre que le 86 % de l'ammonium disparaissant dans le système karstique est oxydé en nitrates, ce qui confirme le pouvoir élevé d'auto-épuration.

On peut noter, enfin, la diminution du flux massique des nitrites entre La Verrerie et le lac de Biaufond (tableau 3), malgré l'apport dû à la STEP. Ce résultat suggère qu'une partie relativement importante des nitrites présents dans le Doubs est oxydée en nitrates.

Part des polluants provenant de la STEP transportés par le Doubs à Biaufond

Le tableau 4 montre les apports totaux de la STEP parvenant dans le Doubs. On constate que les apports en ammonium et en nitrates représentent environ la moitié des arrivées de ces éléments dans le tronçon La Verrerie - Lac de Biaufond, le reste provenant principalement des maisons isolées et de l'activité agricole.

Quant aux apports de COT issus de la STEP, ils correspondent à 15 % des arrivées de ces composés dans le tronçon considéré. Enfin, les quantités d'ammonium et de COT provenant de la STEP représentent le 35% et, respectivement, le 4% de la masse de ces polluants transportée par le Doubs en aval de Biaufond.

Paramètres		Effluents de la STEP	Amont Verrerie	Rasse	Aval Biaufond
Ammonium	[mgN/l]	18,15 ± 7	0,044 ± 0,01	0,88 ± 1,3	0,103 ± 0,07
Nitrates	[mgN/l]	0,5 ± 0,5	1,4 ± 0,2	4,9 ± 1,6	1,5 ± 0,3
Nitrites	[mgN/l]	0,1 ± 0,1	0,024 ± 0,009	0,016 ± 0,009	0,015 ± 0,008
Azote total	[mgN/l]	NE ¹	0,78 ± 0,5	1,1 ± 0,6	1 ± 0,18
Chlorures	[mg/l]	150,4 ± 53,5	5,3 ± 1,5	54,5 ± 26	6,3 ± 1,8
COT	[mg/l]	12,1 ± 2	4,6 ± 1,4	4,2 ± 1,1	4,6 ± 1,2

Tableau 2 : Valeurs moyennes des teneurs en composés azotés inorganiques, en chlorures et en COT dans le Doubs, à la Rasse et dans les effluents de la STEP (9 nov. - 6 déc. 1995)

Paramètres		Effluents de la STEP	Amont Verrerie	Rasse	Aval Biaufond
Ammonium	[kgN/j]	430	52	19	160
Nitrates	[kgN/j]	12	1649	106	2333
Nitrites	[kgN/j]	2,4	28	0,34	23
Azote total	[kgN/j]	NE ¹	929	23,7	1571
Chlorures	[kg/j]	3561	6241	1177	9798
COT	[kg/j]	286	5429	90,7	7092

Tableau 3 : Flux massiques des composés azotés inorganiques, des chlorures et du COT dans le Doubs, à la Rasse et dans les effluents de la STEP (9 nov. - 6 déc. 1995)

Paramètres	Apports totaux parvenant au Doubs sur le tronçon Amont Verrerie - Aval Biaufond	Apports provenant de la STEP ²	Proportion imputable à la STEP ³
	(kg/j)	(kg/j)	(%)
Ammonium ⁴	102	58	54
Nitrates ⁴	684	321	48
Nitrites ⁴	/ ⁵	1,2	/ ⁵
Azote total ⁴	642	73	11,4
Chlorure	3557	3623	100
COT	1843	277	15

Tableau 4 : Apports dans le Doubs en composés azotés inorganiques en chlorure et en COT provenant de la STEP, après passage dans le système karstique

¹ NE : non effectué

² Ces apports ont été calculés en sachant qu'environ 30 % de ceux-ci rejoignent le Doubs par la Rasse

³ La part imputable à la STEP correspond au rapport des apports totaux de l'élément considéré provenant de la STEP sur les quantités de l'élément transportées par le Doubs en aval de Biaufond

⁴ kgN/j

⁵ Le flux massique diminue malgré l'apport dû à la STEP

Discussion

Nous avons montré que l'ammonium rejeté dans les effluents de la STEP est oxydé en nitrates au cours du trajet souterrain de la Ronde. Les résultats indiquent que cette nitrification ne s'effectue pas aux dépens de l'oxygène dissous et qu'elle a lieu pendant toute l'année. On peut conclure que le système karstique est ventilé et que le parcours souterrain se déroule essentiellement en milieu à écoulement libre. Dans un tel écoulement, l'élimination des polluants peut inclure des processus plutôt physiques, tels l'adsorption ou le fractionnement d'organismes vivants. Des études précédentes ont révélé une baisse importante de la concentration en bactéries fécales et en bactériophages de *E. coli* dans ce système karstique (Blant et Stettler 1982; Montandon et al. 1995), le taux de dilution n'étant pas suffisant pour expliquer ces pertes. En ce qui concerne les bactériophages, les analyses ont démontré que le taux d'inactivation des particules infectieuses dépend du type de bactériophage analysé, suggérant une inactivation d'ordre mécanique.

On admet généralement que la rétention des substances polluantes est faible en milieu karstique (Baylet et al., 1987; Caumartin, 1975; Miserez et al., 1976), en raison de la rapidité des écoulements d'eau et de l'insuffisance des couches argileuses qui fixent les polluants et permettent leur destruction par des micro-organismes. Or, les résultats présentés montrent que le système karstique de la Ronde possède des capacités d'auto-épuration qui consistent en une oxydation et non une simple dilution des polluants par des eaux d'infiltration. Une étude récente (Montandon et al., 1995) a d'ailleurs mis en évidence la biodégradation des hydrocarbures aromatiques de la série du benzène dans ce système karstique. En effet, une bactérie capable de dégrader ces composés en condition de laboratoire a été isolée à partir d'un échantillon d'eau prélevé à la Rasse. Les capacités d'auto-épuration de ce système se sont probablement développées de manière progressive depuis la mise en service de la STEP en 1975. Avant la construction de celle-ci, les eaux usées, qui étaient déversées dans des pertes situées 1,5 km en amont de la STEP (figure) et ressortaient aux résurgences de la Verrerie et de la Rasse, étaient contaminées par des teneurs élevées en ammonium (Schardt 1911, Schassmann 1965), suggérant que le système karstique n'était pas capable de nitrifier l'ammonium à cause de la charge trop élevée en matière organique des eaux usées non épurées. La présence d'une STEP, donc d'une source régulière en eaux usées épurées et riche en micro-organismes de différents types physiologiques, a probablement contribué au développement de conditions favorables à la rétention et à l'oxydation des polluants déversés dans le système.

On a, enfin, pu estimer l'impact de la STEP de La Chaux-de-Fonds sur le Doubs par l'analyse des flux massiques des polluants. La part des polluants transportés par le Doubs en aval de Biaufond et imputable à la STEP est vraisemblablement inférieure aux valeurs présentées dans le tableau 4. En effet, nous avons négligé, dans notre calcul du débit du Doubs, les arrivées en chlorures étrangers à la STEP qui parviennent dans le Doubs avec les eaux du bassin versant. Par conséquent, la valeur de débit utilisée pour calculer les flux massiques à Biaufond correspond à une valeur moyenne minimale (voir section « Estimation des débits »), donc à une sous-estimation des flux massiques à cet endroit.

En conclusion, cette recherche représente une première approche dans l'établissement de l'impact de la STEP actuelle sur le Doubs. A terme, nous pourrions déterminer l'effet, sur le milieu

récepteur, des améliorations de traitement, notamment la nitrification, qui interviendront avec la rénovation de la STEP actuelle.

Remerciements

Les auteurs remercient MM. J. Baumgartner, responsable de l'usine hydroélectrique du Châtelot, et R. Boillat, responsable de la STEP de La Chaux-de-Fonds, d'avoir transmis les données concernant les débits du Doubs et à la sortie de la STEP, Mme S. Daval, MM. J.-M. Erard et P. Erard, collaborateurs et stagiaire au Service de l'hygiène et de l'environnement, de leur excellente collaboration tout au long de ce travail, ainsi que Mlle D. Arnoux pour la mise en page du manuscrit.

Références

- BAYLET R., JOSEPH C., RODIER C., SOULIE M., SINEGRE F. : Variation de la qualité bactériologique des eaux karstiques au cours d'un épisode de crue : source du Lez (France) - Novembre 1982. Bull. du Centre d'hydrogéologie de Neuchâtel, 7 : 253-264, 1987.
- BLANT J.D., STETTLER R. : Survie des bactéries indicatrices de pollution fécale dans un cours d'eau. Bull. Soc. Neuch. Sci. Nat. 105, 89-105, 1982
- BOURQUIN P., SUTER H., ET FALLOT P. : Carte géologique de la Suisse, feuille 15 Biaufond - Les Bois - La Ferrière - St-Imier, 1946
- BOURQUIN P., BUXTORF R., FREI E., LUTHI E., MUHLETHALER C., RYNIKER K., SUTER H. : Carte géologique 1: 25'000 de l'atlas géologique de la Suisse, feuille 51 Val-de-Ruz, 1968
- CAUMARTIN V. : Les mécanismes de recyclage des eaux en milieu karstique. Actes du 5^{ème} Congr. nat. de spéléologie, septembre 1974, Interlaken, R. Gigon (Ed.) Soc. Suisse de Spéléologie, Neuchâtel : 79-85, 1975.
- FAVRE J. : Description géologique des environs du Locle et de la Chaux-de-Fonds. Eclogae geol. Helv., XI: 369-475, 1911
- MATTHEY B. : Les ressources en eau du canton de Neuchâtel dans le cadre de l'aménagement du territoire. Matthey B. (Ed.), Montézillon (NE), Suisse, 1989.
- MATTHEY B. : Eaux souterraines. Dans : Centre d'identification, de traitement et de recyclage des déchets spéciaux CITRED, protection de l'environnement, étude de faisabilité, ATESA (éd), République et canton de Neuchâtel, dép. trav. publ., novembre 1990.
- MISEREZ J.J. SIMEONI G.P., BERNASCONI R., BRANDT C., DEPALLENS O., DOMONT G., KELLENBERER Y.S., MOESCHLER O., VOISIN G. : Essai sur le pouvoir d'auto-épuration des eaux karstiques. Stalactite 26/1, 13-28, 1976
- MONTANDON P.E., MAGES J.F., MISEREZ J.F. : Etude de l'écoulement du système karstique. Exemple de la vallée de la Ronde (NE, Suisse). Bull. du Centre d'hydrogéologie de Neuchâtel, 14: 177-198, 1995.
- ROGNON P. : Impact sur le milieu récepteur d'une station d'épuration dont les effluents transitent par un système karstique. Travail de diplôme, Ecole polytechnique fédérale de Lausanne, Suisse, 1996.
- SCHARDT H. : Le cours souterrain de la Ronde. Bull. Soc. Neuch. Sci. Nat., 37 : 3-18, 1911
- SCHMASSMANN H. : Ursachen, Folgen und Bekämpfung von Grundwasserverunreinigungen in der Schweiz. In : Internationales Jahrbuch Chemische Industrie, Druck und Verlag Vogt-Schild AG, Solothurn, Schweiz p. 3-16, 1965.

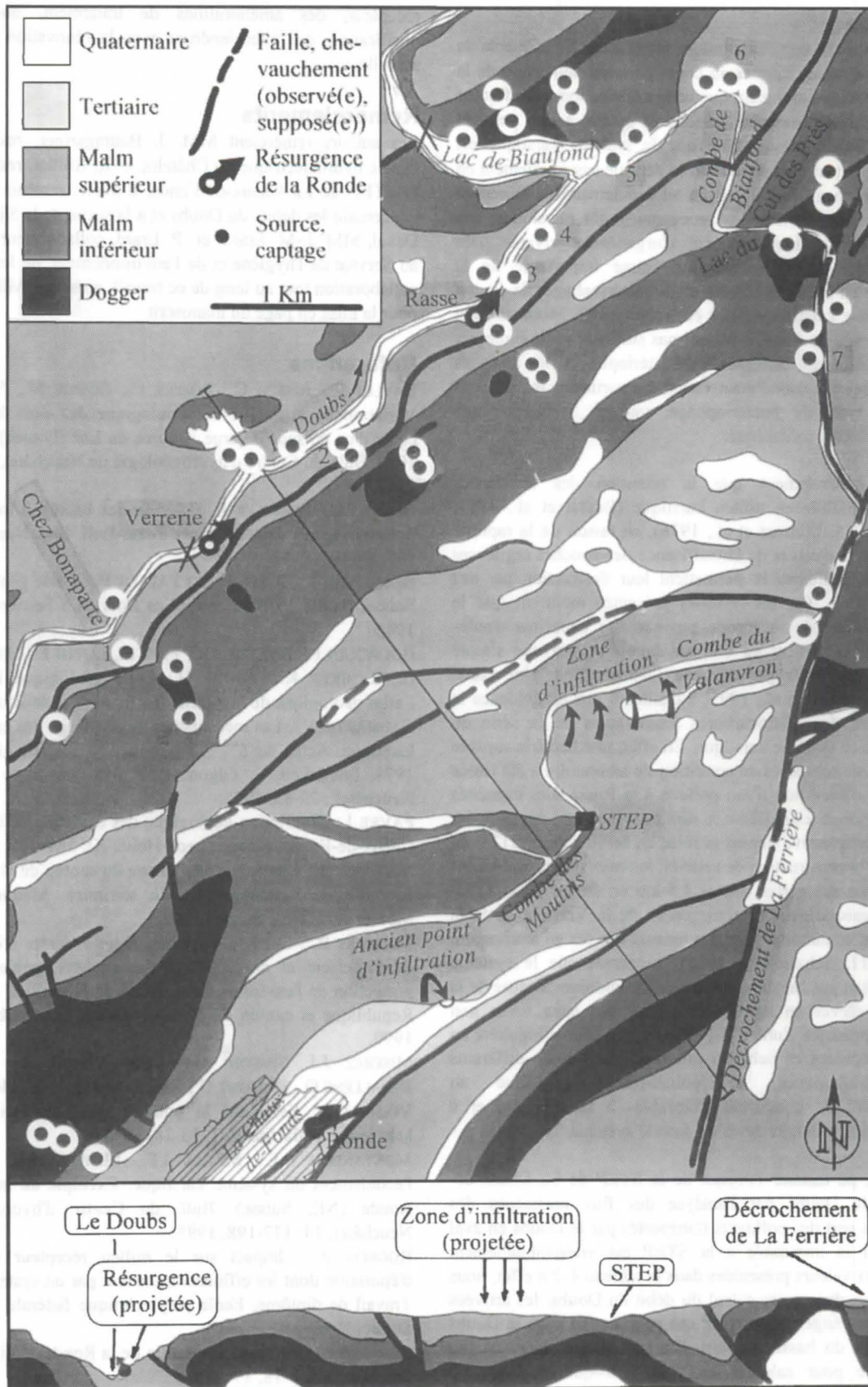

Figure : Carte de situation avec esquisse tectonique, coupe géologique schématique, zones d'infiltration ancienne (avant 1975) et actuelle de la Ronde, résurgences principales et autres sources ou captages : •1: Chez Bonaparte; •2: Moulinet; •3: Tunnels; •4: Dames; •5: Grande et Petite Rondes; •6: Bas de Combe; •7: Fief. Les points de prélèvement dans le Doubs sont indiqués par un X (Modifié d'après Bourquin et al. 1946).

Variability of Cl⁻ ion in water inflows to karst-fissured limestone „Zakrzówek” quarry (Cracow, Poland)

by Jacek Motyka and Adam Postawa

University of Mining and Metallurgy, PL 30065, Cracow, Mickiewiczza 30., Poland

Abstract

Chemical composition of water outflowing in the „Zakrzówek” quarry (Cracow, SW Poland) developed in fractured and karstified Upper Jurassic limestones is controlled by infiltration of polluted water from the Vistula River and by infiltration of meteoric water into clastic rocks in the neighbourhood of limestone complex.

The river water belong to Cl-Na type with TDS up to 2.5 g/L while the water from inflows in the quarry have 0.6 - 2.0 g/L TDS. Highly mineralised ones belong to Cl-Na type. With the decreasing TDS percentage of SO₄, Ca, Mg and HCO₃ increases which seems to be a result of the interference of various processes: dilution of polluted river water, leaching of aquifer rocks and ion exchange (Na-Ca).

Concentration of Cl⁻ ion varies in wide range. Significant variability is observed in both time and space which will be described in present paper. Authors attempt to explain reasons of this variability.

1. Introduction

Presently inactive „Zakrzówek” quarry is situated in a southern suburb of Cracow, in the area of small horst structure known as „The Twardowski Rocks”. The structure comprises Upper Jurassic limestones which had been mined from 1953 till 1991 and utilised as a raw material for soda production in the neighbouring „Solvay” chemical plant. The deepest exploitation level reached the depth of about 60 meters below surface, i.e. about 25 meters below the water level of Vistula River which flows 600-900 meters west from the western corner of the quarry. The hydrodynamic conditions facilitate the infiltration of river water into the pit. In a neighbourhood of the „Zakrzówek” quarry there are located a few abandoned small open pits with their bottoms above the water level in the river. These pits played certain role in recharging of inflows in the quarry.

The Vistula river in Cracow is highly polluted, mostly by mineralised water originating from dewatering of coal mines in the Upper Silesian Coal Basin. Brines released to the river may reach up to 370 g/L TDS (Rózkowski, Rudzinska, 1983). Significant pollution is provided also by agriculture (fertilisers, pesticides and insecticides), by sewages and industrial wastes. Localisation of the „Zakrzówek” quarry in the neighbourhood of the river bed enabled the multidirectional hydrogeological studies. One of the most interesting problems of both the scientific and practical importance is variability of chloride ion concentrations in water flowing into the quarry. This problem is described in the present paper.

2. Hydrogeological background

The main water level of the Zakrzówek horst is located in fractured and karstified Upper Jurassic (Malm) limestones. The fault-bordered and uplifted limestone complex is surrounded by Quaternary sediments (Fig. 1) which include water-bearing alluvia, sands and gravels. These sediments are in direct hydraulic connection with the Vistula river (Fig. 1). Average hydraulic conductivity of Quaternary sands and gravels is $k = 2.8 \cdot 10^{-4} \text{ m/s}$ (Motyka et al., 1995). Along the eastern and northern margins of the Zakrzówek horst Quaternary sands are thin and dry. Further east- and northward these sediments grade into poorly permeable clays, alluvial muds and deluvial pelites. Along the southern margins of the horst Quaternary sands and gravels are thicker and water-bearing, and contact laterally with the Upper Jurassic limestones (Fig. 1).

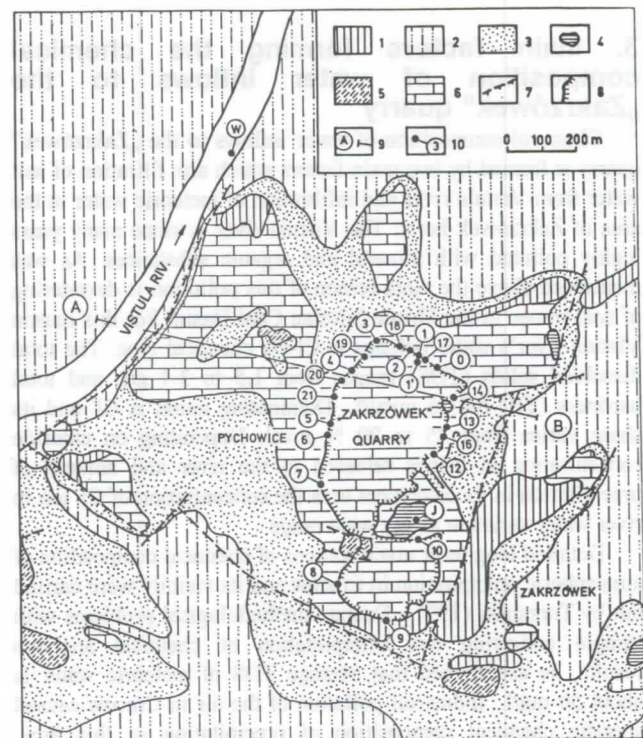

Fig. 1. Geological map of the Zakrzówek horst. Quaternary: 1 - embankments and dumps, 2 - sands, 3 - alluvia, deluvia, loess. Tertiary: 4 - clays. Cretaceous: 5 - marls, marly limestones. Jurassic (Malm): 6 - massive and bedded limestones. 7 - faults, 8 - boundary of the Zakrzówek Quarry, 9 - cross-section, 10 - sampling points.

In the limestones tree systems of water flow showing different hydrogeological properties can be marked out, which are: pore space, fissures, caverns. Pore space, Chouquette & Pray (1970) sense, comprises all empty spaces present in a small rock sample regardless of their genesis. Open matrix porosity, determined by laboratory testing of 418 samples ranges from 0.008 to 0.166. The average porosity is $p_0 = 0.076$ (with standard deviation $s = 0.041$).

Fractures and interbedding planes are the main conduits of underground water flow. Wide fractures particularly favourable for water transfer occur in weathered parts of the horst and in tectonic zones. On the walls of the quarry many are high-angle fractures (70 - 90°) in few meters spacing can be seen. Probably they continue in long distances. Dominating fractures belong to the two systems: NE-SW and NW-SE.

Limestone beds are usually 1-2 m thick and dip gently (at some degrees) to the east i.e. from Vistula river to the quarry. Main flow system constituted of fractures and interbedding planes is supplemented by different karst features: anastomoses, caverns, caves, and large wells and cones filled up with clastic sediments (sands, clayey sands and clays). In the area of Zakrzówek horst was discovered 9 caves with complicated systems of passages and chambers. The caves are developed on fissures and interbedding planes network. Main directions of passages and smaller caverns are in general conformable to fissures strike. Dominating are NW-SE and NE-SW directions. Minor role play W-E and NE-SW directions, characteristic for smaller caverns.

3. Main factors forming the chemical composition of water inflows to the „Zakrzówek” quarry

Chemical composition of water inflows to the „Zakrzówek” quarry is formed by two main factors which are: filtration of salt water from Vistula river and infiltration of meteoric water in the area of Zakrzówek horst. The Vistula river is since many years highly polluted with mineral and organic substances. As was mentioned above the main reason of this pollution is dewatering of coal mines in the Upper Silesian Coal Basin. For this reason Vistula river's water belongs to Cl-Na chemical type. The total dissolved solids (TDS) ranges from 1.5 to 3.4 g/L and total hardness (TH) 8.4,15 mval/L. Dominating anion is Cl⁻ and its share varies from 75 to 90 % mval. Depending on chloride concentration in brines released to the river and amount of precipitation in its catchment area the concentration of Cl⁻ ion in river water varies in a very wide range.

Detailed long term investigations of chemical composition of atmospheric precipitation in Cracow and its vicinity were carried out by Turzanski (1991). Despite methodological problems with sample collecting and interpretation of chemical analyses results, he established that average TDS of meteoric water is about 50 mg/L. Industrial pollution of the air in Cracow caused specific chemical composition of precipitation in this area. Dominating anion is SO₄²⁻ with average content of 60±70 % mval. Dominating cation is Ca (60±70 % mval). Average concentration of Cl⁻ ion is 6.5 mg/L.

During intensive dewatering of „Zakrzówek” quarry numerous water inflows with different yields was observed. Total number of the noted inflows was some about 60. The most intensive were the ones in northern part of the quarry (up to 7 L/s). They formed the continuous zone of many, nearly located inflows flowing out of the single interbedding plane situated 8 meters above the open pit floor. Other inflows were observed in different parts of the quarry, at highs from one to few meters above the bottom of the pit and they have yields not exceeding the value of one litre per minute.

In the northern and north-eastern parts of the quarry Cl-Na, Cl-Na-Ca and Cl-SO₄-Na-Ca water types dominated. Water from No. 16 inflow which showed the highest mineralisation (TDS) belonged to Cl-Na type. With decreasing TDS the contents of Ca and SO₄ followed by HCO₃ increased. In some inflows (No. 3 and 12) of lower mineralisation, Mg ion appeared. In the

western and southern parts of the pit where mineralisation varied from 0.6 to 0.9 g/L the water revealed polyionic character. Most common were five- and six-ion, compositions (Ca-Mg-HCO₃-SO₄-Cl or Ca-Mg-Na-HCO₃-Cl-SO₄). The appearance of magnesium ion in this part of quarry increased.

4. Spatial variability of chloride concentration.

Concentration of Cl⁻ ion determined in water from inflows in „Zakrzówek” quarry showed very strong spatial variability. In north-eastern part of the quarry chloride concentration was „mosaic-type” (Fig. 2). Percentage difference of Cl⁻ concentration in adjacent inflows reached up to 300%. In eastern part of the open pit chloride content was lower and more equalised, ranging from 60 to 90 mg/L. Concentrations increased south-wards of the quarry where reached 100±260 mg/L.

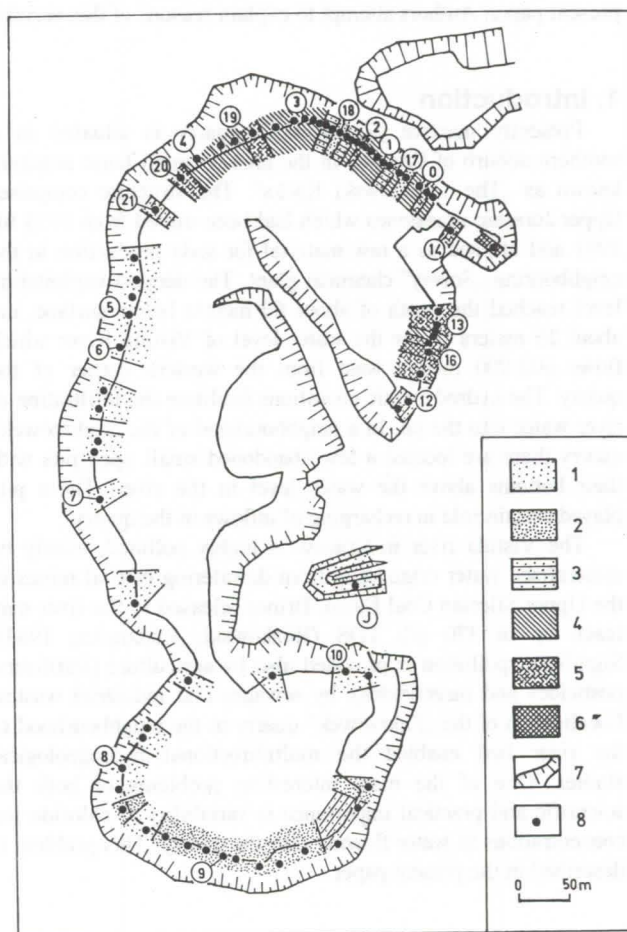

Fig. 2. Chloride contents (in mg/L): 1 - up to 100; 2- 100±200; 3 - 200±300; 4 - 300±500; 5 - 500±700; 6 - over 700, 7 - boundary of the Zakrzówek Quarry, 8 - sampling points

5. Variation of chloride content in time.

Investigations of variability of chloride content in water from inflows in „Zakrzówek” quarry in time, were carried out in years 1990±1992. At first samples were collected from 11 inflows. From January of 1991 number of sampling points increased to 18 and from October to 20. Additionally samples from Vistula river and small artificial reservoir at the surface, in southern vicinity of the quarry were collected.

Superposition of complicated hydraulic system and two different input functions (varying chloride concentration in Vistula river and meteoric water) strongly influenced the variability of Cl⁻ concentrations in investigated inflows. Actually, in each single monitored inflow chloride content varied in different way however a few types of this variability can be pointed out.

Group B - inflows 2, 3 and 19 (Fig. 3B)

Amplitudes of long-term variations of chloride concentration in water from these inflows were relatively small but some temporary, very high variations were noted. Rapid decreases of Cl⁻ concentrations appeared after periods of downpours or snow melting. In such periods intensive dilution of water recharging described inflows was the main factor determining their chemical composition.

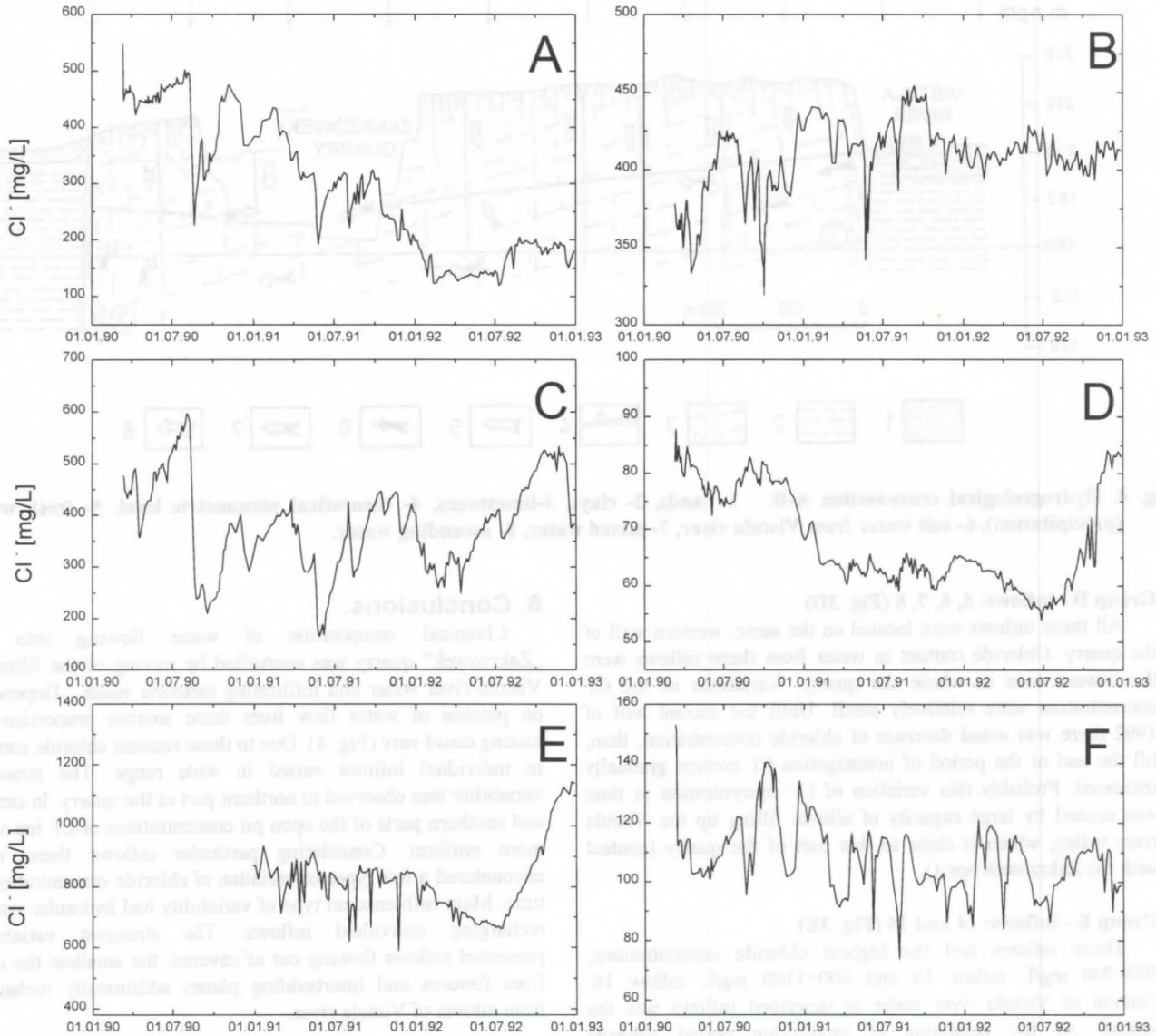

Fig. 3. Concentrations of Cl⁻ ion in selected inflows.

Group A - inflows 0 and 1 (Fig. 3A)

Characteristic for these inflows were high amplitudes of variability of Cl⁻ ion content, ranging from 400÷500 mg/L to 100÷200 mg/L. The most probable reason of this decrease of chloride concentration was capturing of part of water from Vistula river recharging these inflows, by inflows located in north-eastern part of the quarry (inflows 14, 16, 13) which were activated by mining operations. It is also possible that vertical fractures leading meteoric water were additionally widened and dilution of Vistula river water by meteoric water with low Cl⁻ ion content took place.

Group C - inflows: 4, 12, 13, 17, 18 (Fig. 3C)

This group of inflows is characterised by the largest short-term variations of chloride concentration. Particular intensive variability was noted in case of inflows 12 and 13. Both of them flowed out of a small cavern, therefore hydraulic resistance was relatively high (in comparison to fissures and interbedding planes). Proportions between two major components forming the chemical compositions of water in these inflows (Vistula river water and meteoric water) could easily change.

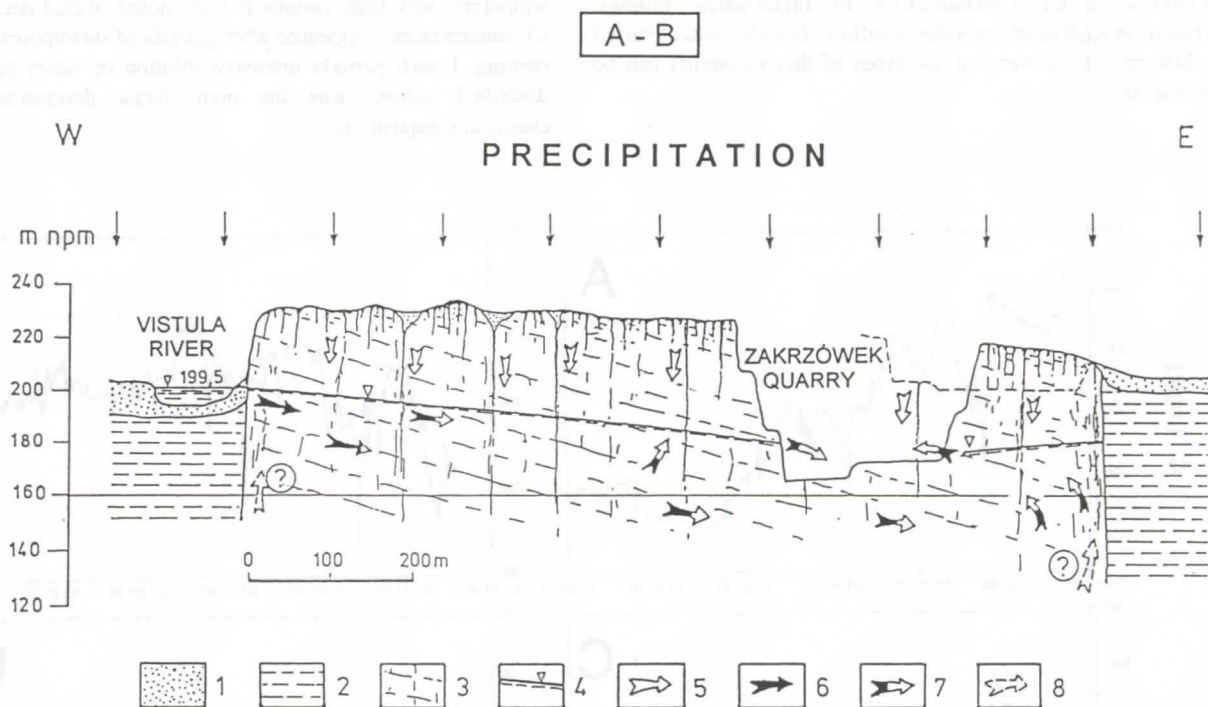

Fig. 4. Hydrogeological cross-section A-B. 1- sands, 2- clays, 3-limestones, 4- theoretical piezometric level, 5- fresh water (precipitation), 6- salt water from Vistula river, 7- mixed water, 8- ascending water.

Group D - inflows: 5, 6, 7, 8 (Fig. 3D)

All these inflows were located on the same, western wall of the quarry. Chloride content in water from these inflows were the lowest ones in whole the quarry. Variations of the Cl⁻ concentration were relatively small. Until the second half of 1992 there was noted decrease of chloride concentration, then, till the end of the period of investigation Cl⁻ content gradually increased. Probably this variation of Cl⁻ concentration in time was caused by large capacity of alluvia filling up the Vistula river valley, which is close to this part of the quarry (contact with the Zakrzówek horst).

Group E - inflows: 14 and 16 (Fig. 3E)

These inflows had the highest chloride concentrations, 500÷700 mg/L inflow 14 and 600÷1100 mg/L inflow 16. Content of Vistula river water in described inflows was the largest. At the beginning of monitoring period chloride concentrations in water from these inflows showed decreasing trend, then rapid increase of concentration was observed. Variations of chloride concentration in water from inflows are very similar to variations of Cl⁻ concentration in Vistula river water.

Group F - inflows 9 and 10 (Fig. 3F)

Changes of chloride content in water from these inflows were very irregular. Large temporary increases and decreases of Cl⁻ concentrations were observed. It seems that the main role in this case played infiltration of meteoric water. Considering inflow 9, important additional factor could be leaching of chlorides from waste materials, mostly gangues from overlays of limestones, deposited at the surface, just above the inflow. Presumably on this tip were deposited also waste materials from the „Solvay” soda plant, contenting chlorides.

6. Conclusions.

Chemical composition of water flowing into the „Zakrzówek” quarry was controlled by mixing of the filtrating Vistula river water and infiltrating meteoric water. Depending on patches of water flow from these sources proportions of mixing could vary (Fig. 4). Due to these reasons chloride content in individual inflows varied in wide range. The strongest variability was observed in northern part of the quarry. In central and southern parts of the open pit concentrations of Cl⁻ ion were more uniform. Considering particular inflows there were encountered a few types of variation of chloride concentration in time. Main influence on type of variability had hydraulic system recharging individual inflows. The strongest variability presented inflows flowing out of caverns, the smallest the ones from fissures and interbedding planes additionally recharged from alluvia of Vistula river.

References:

CHOUQUETTE, P.W. & L.C. PRAY. 1970. Geologic nomenclature and classification of porosity in sedimentary carbonates. *The Am. Assoc. of Petrol. Geol. Bull.* 54,2: 207-250.
 MOTYKA, J., A. POSTAWA & S. WITCZAK. 1995. Bank filtration of contaminated Vistula river water to the karst-fissure Jurassic limestones (Cracow region). *Arch. Ochr. Srod.*, 1: 73-86.
 RÓZKOWSKI, A. & T. RUDZINSKA. 1983. On the origin of groundwater in the Upper Silesian and Lublin Coal Basins (in Polish). *Przegl. Geol.*, 6: 370-376.
 TURZANSKI, K.P. 1991. Pollution of precipitation waters in southern Poland. Acid rains and their monitoring (in Polish). *Zesz. Nauk. AGH, 1433, Sozol. i Sozotech.* 34, Kraków, 106p.

Microbiologic Activities in open Karst Aquifers with Matrix Porosity and Consequences for Ground Water Protection in the Franconian Alb, Germany

Elisabeth Müller, Klaus-Peter Seiler

GSF-Institut of Hydrologie, Neuherberg, Oberschleissheim, Germany

Anton Hartmann

GSF-Institut of Soil Ecology, Neuherberg, Oberschleissheim, Germany

Abstract

Tracing tests and the analyses of environmental isotopes (e.g. ^3H) in ground waters of the Karst of the Franconian Alb demonstrates a significant dilution and disintegration potential for pollutants entering the reef facies. In the bedded facies both mechanisms have not been detected. This originates from a considerable matrix porosity in which pollutants enter mainly by diffusion processes and undergo long turnover times. Recent isolations of microorganisms from karst ground waters demonstrate a density of populations reflecting the intensity of land use and a rather quick decomposition of nitrates towards NO_2 , N_2O and N_2 . It seems that a significant decomposition potential exists also for pesticides.

Résumé

Des traçages et des analyses d'isotopes de l'environnement (p.e. ^3H) montrent que le faciès des récifs du karst franconien (Malm) disposent d'un haut potentiel de dilution et de désintégration microbiologique pour des polluants dans les eaux souterraines. Dans le faciès stratifié, au contraire, ces deux mécanismes manquent. Toutes ces observations sont liées à la porosité assez grande de la matrice des calcaires dans laquelle les polluants pénètrent par diffusion et y restent plusieurs dizaines d'années et jusqu'à cent ans. Des études récentes dans le karst franconien montrent une assez grande densité de populations microbiologiques qui reflète à peu près celle des cultures observées en surface dans les zones considérées. Les aquifères montrent un assez fort potentiel de dénitrification qui part du nitrate dans l'eau souterraine au NO_2 et à travers le N_2O jusqu'à l'azote élémentaire. Ces recherches montrent aussi la possibilité d'une désintégration microbiologique pour la plupart des pesticides en raison du temps de rétention assez long des eaux de matrice.

1 Introduction

The frequency distribution of individual flow velocities in aquifers with heterogeneous pore geometries produce as a rule a wide and mostly discontinuous range of flow velocities. From this storage and drainage conditions for seepage and ground water flow originates and produce problems related to ground water exploration and to both short-term and long-term aspects of ground water protection. Carbonate rocks of the reef facies are typical representatives of such heterogeneous aquifers and have been studied in detail in the Franconian Alb, Bavaria, applying artificial and environmental tracers as well as microbiological studies.

2 Porosities and permeabilities of the Malm carbonates of the Franconian Alb

The carbonates of the Franconian Alb, Bavaria, belong to two consecutive cycles of sedimentation, each starting with marls or marly limestones and ends with bedded limestones. In the upper cycle, however, reefs replace limestones over significant stratigraphic intervals. Bedded limestones typically lack syngenetic porosity and fissure porosity amounts to less than 2 vol.%, unlike the bedded limestones, the reef dolomites commonly have matrix porosities of sedimentary and early diagenetic age and simultaneously have fissure porosities.

Matrix porosities in the reef facies range predominantly between 5 and 10 vol.% with bottle neck openings between 0.1 and 100 μm ; hydraulic conductivities determined by means of pumping tests range predominantly between 10^{-3} and 10^{-6} m/s (HARTMANN, 1994) and are independent from the respective carbonate facies; on the contrary, matrix permeabilities are missing in the bedded facies and have been determined by means of laboratory experiments to be lower than 10^{-7} m/s (WEISS, 1987).

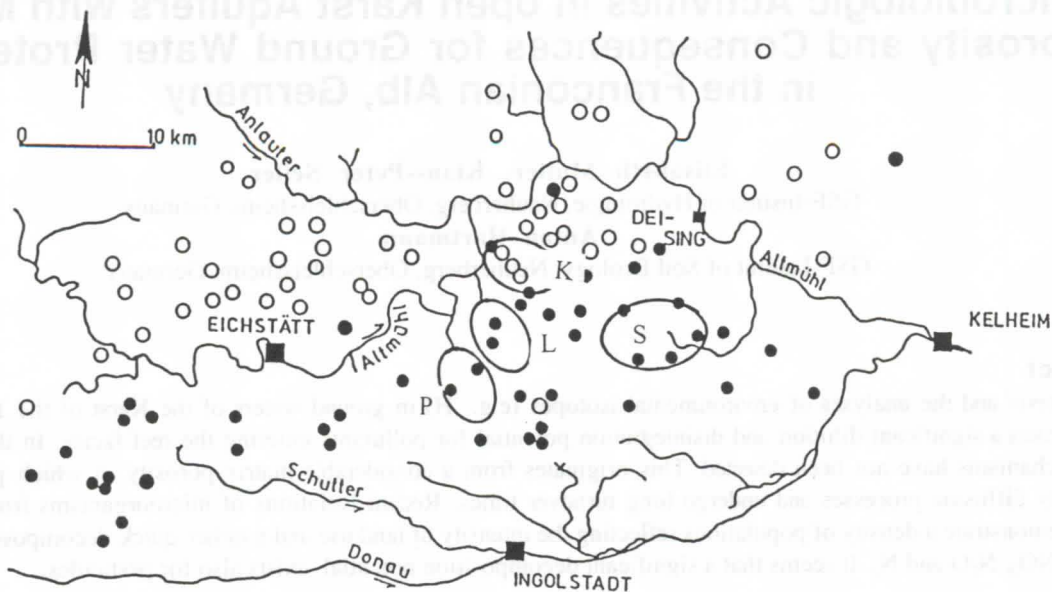

Figure 1: Areas with (open circles) and without responses (filled circles) to tracing tests with fluorescent dyes

3 Results of tracer and incubation tests

The area of research covers about 1,000 km² (Fig. 1). About half of the tracer tests have been performed in the bedded facies and both tracer recovery and flow velocities were mostly high and tracers propagate in narrow tracer plumes. Tracer tests in the reef facies, however, ended mostly at distances exceeding 1.5 to 2 km without recovery, during an observation time of more than 7 years (SEILER et al. 1991). In both facies ground water recharge (250 mm/a) and the non-reactive behaviour of the tracers is the same all over the area. Therefore enhanced dilution of tracers in the reef facies exceeding the normal hydrodynamic dispersion must be attributed to matrix porosities and preferential diffusion processes perpendicularly to flow direction.

Tritium in ground waters

Tracer tests mostly provide information about small sectors of the ground water flow field and often indicate preferential flow. In contrast, environmental isotopes like Tritium can be used to get areal and statistically well based informations on the ground water flow field. During the dry season, for example, Tritium concentrations in ground waters out of the bedded facies equal to the mean for precipitations of the last foregoing years, and in areas with low tracer recovery Tritium concentrations are significantly lower than the weighted means of local precipitations. The determination of mean residence times on the base of a 15 years sampling at dry weather discharge (1980-1995) using an exponential age distribution delivered for the reef facies mean residence times between several tenth to few hundreds of years.

Fate of nitrates in the reef facies

In the area of research nitrogen excesses available to seepage waters amount to about 40 kg/ha/y and ground water recharge ranges at 250 mm/y. From these rates a concentration of 71 mg NO₃/l was expected in the Karst ground waters. Ground water samples from of the bedded facies have nitrate concentrations reaching a maximum of 80 mg/l, contrary in the reef facies nitrates amount only to 15-20 mg/l.

Waters of springs and wells of the reef facies from areas used by agriculture (A1-A2 in Fig. 2) and forestry (A3-A4 in Fig. 2) have been sampled. The total bacterial numbers (DAPI-stain) and colony forming units (cfu) on R₂A agar (aerobic incubation, 22°C) as well as on a denitrification agar (R₂A agar + 0,5% KNO₃, anaerobic incubation, 22°C) has been determined. In the samples taken under agricultural areas, the numbers of total and viable counts are higher as compared to ground water samples under forested areas. Obviously some biodiversity preexists in the aquifers and the number of colonies is enabled to grow to some extend according to the intensity of land use. It is, however, not yet well understood if this growth was linked to any incubation time.

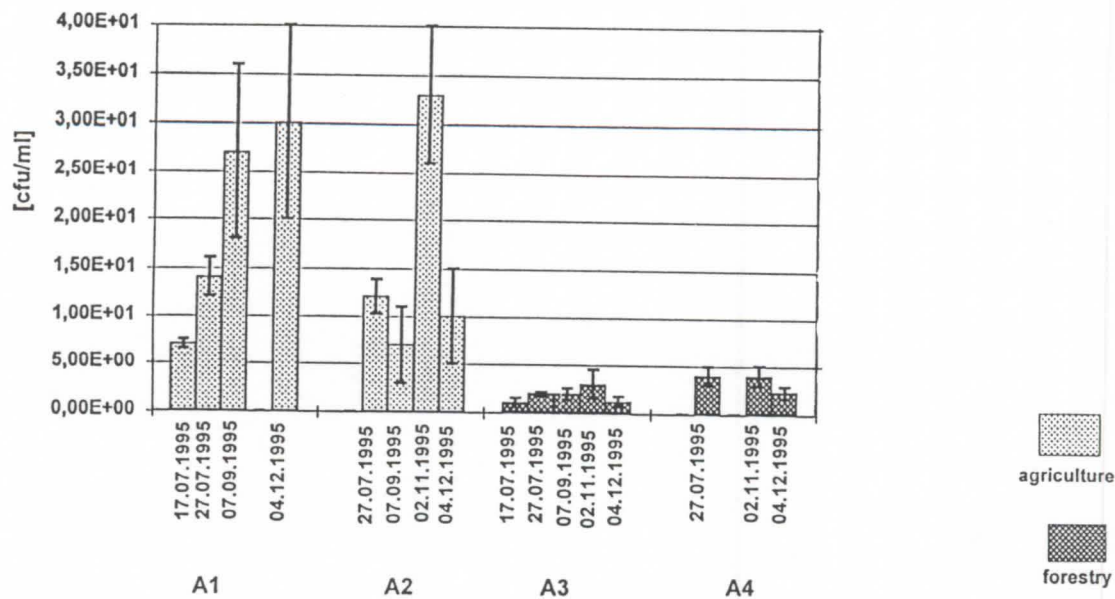

Figure 2: Colony forming units (cfu) on denitrification agar (R_2A agar + 0,5% KNO_3) in anaerobic conditions in ground waters of the reef facies

To study the denitrification potential of ground waters samples have been taken in the reef facies under arable and forested areas, respectively, and standardised to 50 mg/l NO_3^- ; no supplementary carbon source was added and the water samples were incubated for 3 weeks under anaerobic conditions. The DOC content of the groundwater samples of both areas was about 2 mg/l and the natural nitrate concentration was 9-12 NO_3^- mg/l. The NO_3^- , NO_2^- and N_2O ratios in the water samples have been measured and in sterile control samples no denitrification activity was determined; in all samples denitrification occurred and was significantly quicker in the samples from agricultural areas. These results demonstrate, that the ground waters of these karst areas exhibit a substantial denitrifying activity, despite of very low organic carbon supply. It is hypothesised, that some autotrophic activity exists in these highly carbonated water samples (380 mg/l HCO_3^-).

4 Conclusions for the delineation of ground water protection areas

In bedded limestones contaminants commonly cause very rapid and serious responses in the ground water. Consequently, in cases of the use of ground waters for drinking water purposes, very rigid ground water protection measures have to be taken all over the catchment area. In the reef facies, in contrast, response to both accidental and permanent pollution will only be strong in an area of 1.5 to 2 km in distance from the spring or well. In this zone, tracer experiments should be executed to get informations on dilution potential and preferential flow. In this delineated zone handling of potential ground water pollutants must be restricted.

At greater distances from the spring or well, dilution and disintegration potential may be sufficient to eliminate non-persistent pollutants. In this zone mean turn over times must be determined in order to know to which degree pollutants will be metabolised or mineralised. In this zone only handling with persistent pollutants must be restricted.

Since pollutants may enrich gradually in matrix porosity and result in significant long-term risks for ground water quality, special monitoring programs have to supervise the development in storage of pollutants in this outer zone.

References

- HARTMANN, J.-W. 1994: Untersuchungen zur Durchlässigkeitsverteilung des Malmaquifers der Südlichen Frankenalb unter Anwendung hydrogeologischer, gefügekundlicher und fernerkundlicher Methoden. *GSF-Bericht 23/94*: 120 S.
- SEILER, K.-P., H. BEHRENS, H.-W. HARTMANN 1991. Das Grundwasser im Malm der Südlichen Frankenalb und Aspekte seiner Gefährdung durch anthropogene Einflüsse. *Deutsche Gewässerk. Mitteilungen 35*: 171-179; Koblenz
- WEISS, E.G. 1987. Porositäten, Permeabilitäten und Verkarstungserscheinungen im Mittleren und Oberen Malm der Südlichen Frankenalb. *Dis. Univ. Erlangen*, 211 S.

«L'image» de la fracturation et de la karstification dans le jura suisse par prospection magnétique

par Imre Müller & Pascal Turberg

Centre d'hydrogéologie de l'Université, Rue Emile-Argand 11, CH-2007 Neuchâtel, Suisse

Abstract

Vulnerability of karstic aquifers essentially depends on fracturation and karstification patterns of the rock, mainly in its uppermost part called "epikarst". In the Swiss Jura mountain, frequency and intensity of fracturation is usually out of direct observation because of the presence of a Quaternary cover from eolian or glacial origin. These deposits which also massively infiltrate open fracture zones of the rock are made of minerals and fragments of igneous and metamorphic rocks, the magnetic susceptibility of which is high compared with the one of limestone. The use of magnetometry with continuous data recording along profiles enables the detection of weak distortions of the magnetic field caused by these Quaternary deposits and leads to an indirect imaging of fracture zones. Magnetometric measurements can therefore help hydrogeologists to carry out evaluations of vulnerability in karstic environments.

Résumé

La vulnérabilité des aquifères karstiques dépend essentiellement de l'état de fracturation et du degré de karstification de la roche calcaire, surtout dans la partie tout à fait superficielle des réservoirs appelée «épikarst». Dans le Jura suisse, la fréquence et l'intensité de la fracturation échappe souvent à l'observation directe, car les roches sont recouvertes de dépôts quaternaires, éoliens ou morainiques. Ces dépôts, qui infiltrent massivement les fractures ouvertes de la roche, contiennent des minéraux et des débris de roches ignées et métamorphiques dont la susceptibilité magnétique est élevée en comparaison de celle des formations calcaires. La prospection magnétique «en continu» permet de détecter les faibles distorsions du champ magnétique dues à ces remplissages quaternaires, et fournit ainsi une «image» indirecte de la fracturation qui s'ajoute aux observations usuelles dont l'hydrogéologue dispose pour estimer la vulnérabilité d'un aquifère calcaire.

1. Introduction

Pour faciliter le travail des hydrogéologues et améliorer de façon réaliste la rapidité et l'efficacité des travaux destinés à la protection des aquifères karstiques, une approche globale de la vulnérabilité a été récemment proposée (DOERFLIGER & ZWAHLEN, 1995; DOERFLIGER, 1996) sous le nom d'EPIK (Epikarst, Protective cover, Infiltration conditions, Karstic network). Basée sur une synthèse cartographique multicritère, où les facteurs essentiels influençant la vulnérabilité sont réunis, la méthode EPIK met l'accent sur l'importance de l'existence ou de l'absence d'une zone très perméable, hiérarchiquement organisée, à la surface de l'aquifère, appelée épikarst (MANGIN, 1975). L'épikarst joue en effet un rôle primordial sur la vitesse d'infiltration des eaux de surface, et par conséquent sur la vulnérabilité des eaux souterraines. Parmi différentes méthodes utilisées classiquement pour caractériser l'épikarst, les auteurs proposent les études géomorphologique, topographique, photogéologique ainsi que l'analyse de la fracturation.

En pratique, l'analyse de la fracturation n'est pas toujours réalisable, faute d'affleurement et faute de temps. De même, l'usage des documents photogéologiques est souvent difficile car la roche en place est fréquemment masquée par la couverture végétale.

De nouvelles méthodes électromagnétiques, efficaces et expéditives pour la reconnaissance de la fracturation ont été développées depuis une quinzaine d'années par le Centre d'Hydrogéologie de l'Université de Neuchâtel (MÜLLER, 1982; TURBERG & MÜLLER 1992 ; MÜLLER et al. 1995). La possibilité d'enregistrer en continu les paramètres de l'induction électromagnétique constitue actuellement un progrès important dans la détection des zones fracturées et dans la compréhension des structures hiérarchiquement

organisées. La saisie rapide des paramètres géophysiques, sans contact au sol, révèle une «image» géologique jusqu'alors inconnue, une nouvelle dimension pour la diagnose du milieu fracturé. Il n'est donc pas surprenant qu'encouragés et fascinés par ces premiers résultats, nous ayons cherché à expérimenter d'autres méthodes géophysiques sans contact au sol.

Une méthode intéressante et prometteuse est la magnéto-métrie, pour autant que les mesures du champ magnétique total et du gradient soient effectuées en continu ou avec une fréquence d'échantillonnage élevée. Ainsi, une empreinte magnétique du milieu calcaire de subsurface, susceptible de refléter son état de fracturation, peut être obtenue.

Le présent article illustre quatre séries de résultats magnéto-métriques obtenues sur des formations karstiques du Jura suisse.

2. Les propriétés magnétiques du karst

La prospection magnétique est la plus ancienne des méthodes utilisées en géophysique. Elle est fondée sur l'analyse des anomalies magnétiques, lesquelles sont des distorsions locales du champ magnétique terrestre. Ces anomalies sont provoquées par la présence, dans la roche, de corps aimantables, telle certains minéraux comme la magnétite et l'ilménite. La valeur du champ magnétique terrestre n'est pas constante dans le temps; elle connaît de faibles variations journalières dont il faut tenir compte lors des mesures. L'unité de l'intensité du champ total est le nanotesla (nT). Sa valeur est d'environ 30'000nT à l'équateur et 60'000nT aux pôles. En Suisse, elle est proche de 47'000nT. Le gradient magnétique est mesuré par deux capteurs superposés et est exprimé en nT/m. L'intensité d'aimantation

qu'induisent les minéraux et les roches sous l'effet du champ magnétique terrestre est une propriété physique qu'on appelle la susceptibilité magnétique (K). Elle est mesurée par des instruments appelés kappamètres. Nous citons (d'après MILSOM, 1992) quelques valeurs de susceptibilité, exprimées en SI (Système International). On remarquera que les écarts peuvent être considérables.

Schistes: 0 - 0.002	Rhyolites: 0.00025 - 0.01
Roches salines : 0.000 - 0.001	Calcaires: 0.00001 - 0.0001
Basaltes: 0.001 - 0.1	Gabbros : 0.001 - 0.1
Magnétite: 0.1 - 20.0	Pyrrhotite: 0.001 -1.0

En examinant ces valeurs, on comprendra que, normalement, dans les formations calcaires on ne trouvera pas d'anomalies magnétiques, à moins qu'il n'existe quelque part dans la roche des corps «perturbateurs» dont la susceptibilité est suffisamment importante pour générer des anomalies magnétiques. Ce cas est observé dans les calcaires jurassiens où les dépôts morainiques et éoliens remplissent fréquemment les fissures de la roche. Ces dépôts, qui contiennent de la magnétite et des débris de roches dont la susceptibilité magnétique est élevée, sont capables de fournir des distorsions du champ total et permettent ainsi une localisation indirecte des zones fissurées. Seul un échantillonnage en continu peut individualiser ces faibles anomalies. L'utilisation de magnétomètres perfectionnés, capables d'échantillonner plusieurs fois par seconde s'avère alors nécessaire pour effectuer des profils et des cartes magnétiques suffisamment détaillés.

L'équipement utilisé est un ENVIMAG, magnétomètre à proton de la Maison SCINTREX dont la résolution est de 0.1nT. L'instrument mesure le champ total et le gradient avec un intervalle d'échantillonnage à choix de 0.5, 1 ou 2 secondes.

3. Résultats

Dans la région de la Grotte de Milandre (Bure, canton du Jura) où nous disposons d'un site expérimental dans le karst tabulaire, la prospection électromagnétique RMT et VLF-EM,

ainsi que plusieurs forages de reconnaissance ont permis de localiser avec précision le passage d'une zone de fracture majeure dans les calcaires du Malm. Cet accident tectonique est également bien repéré par la prospection magnétique (MÜLLER et al., 1995). La fig. 1 présente l'un des nombreux profils E-W recoupant deux failles orientées N-S, l'une à environ 40m et l'autre à environ 170 m.

L'anomalie magnétique provient des remplissages quaternaires, surtout éoliens, qui infiltrent ces failles et dont la susceptibilité magnétique sur « cuttings » varie entre $K = 0.4$ à $0.7 \cdot 10E-3$.

La fig. 2 illustre par contre une zone peu fracturée dans la région du Creux du Van (canton de Neuchâtel). L'amplitude des faibles variations répétées du champ total ne dépasse pas les 2 à 3 nT, contrairement à ce qui est observé à la fig. 1 sur une zone de fracture majeure où les amplitudes varient entre 20-30nT.

Sur le calcaire crétacé du Valanginien ou «Marbre bâtard» du col du Marchairuz (canton de Vaud) à la fig. 3 et de Lignières (canton de Neuchâtel) à la fig. 4, les profils magnétiques mesurés présentent des variations resserrées en «dent de scie». L'examen des affleurements en ces endroits montre des dalles calcaires très fracturée et karstifiées. Le remplissage quaternaire de ces fractures semble produire des variations magnétiques importantes, dont les amplitudes et les fréquences, assez similaires sur les deux sites, pourrait être caractéristiques de cette formation du Jura suisse.

Afin d'écarter tout doute quant à la position de l'anomalie magnétique par rapport à celle des structures karstiques ou épikarstiques, il est utile de rappeler que le gradient magnétique (nT/m) est un indicateur précieux dans l'estimation de la proximité du «corps perturbateur». Les deux capteurs du magnétomètre, superposés et distants de 50 cm, mettent d'autant mieux en évidence ces corps qu'ils se trouvent à proximité, c'est à dire qu'ils se trouvent très proche de la surface du sol. En plus, ces mesures de gradient ne sont pas influencées par les changements rapides du champ total. Il est donc intéressant de constater à la fig. 4 que le gradient varie nettement sur les anomalies du Marbre indiquant bien que le remplissage détecté est superficiel.

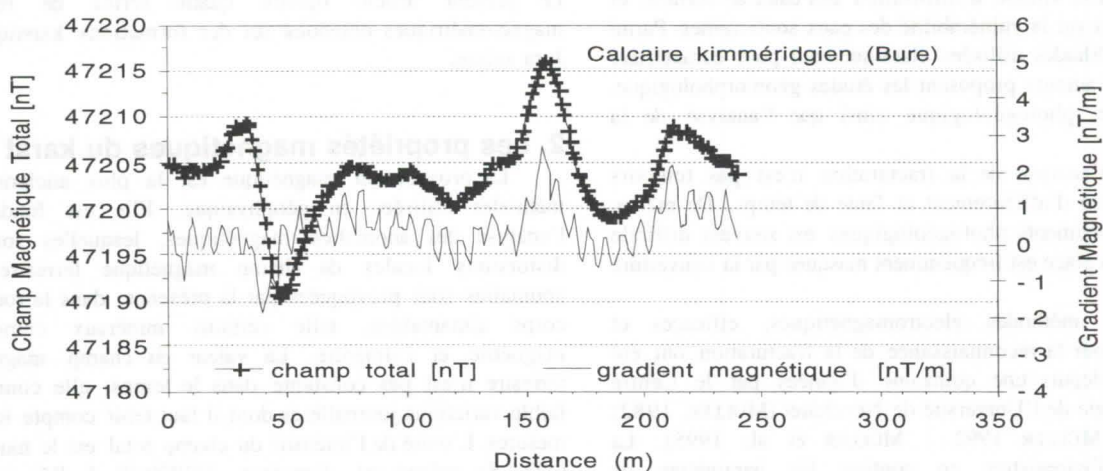

Fig. 1: Profil magnétique (champ total et gradient) sur une zone fracturée majeure du Kimméridgien (Bure, canton du Jura, Suisse).

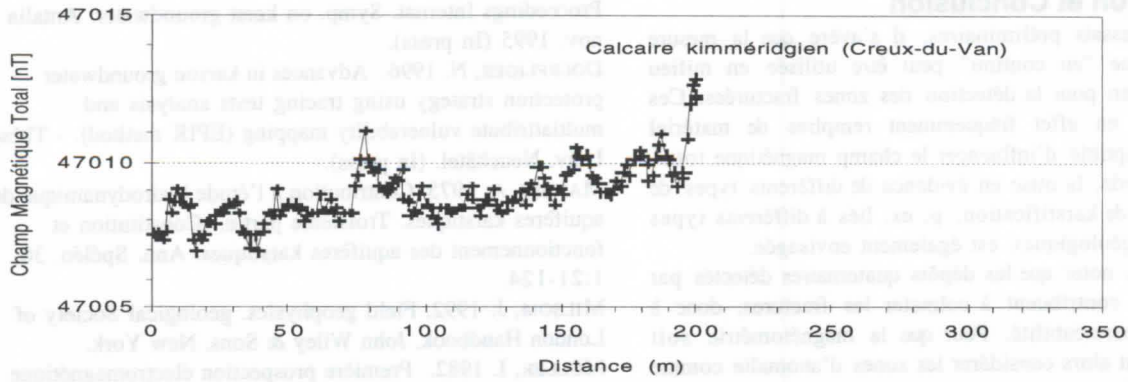

Fig. 2: Profil magnétique (champ total) sur une zone faiblement fracturée du Kimméridgien (Creux-du-Van, canton de Neuchâtel, Suisse).

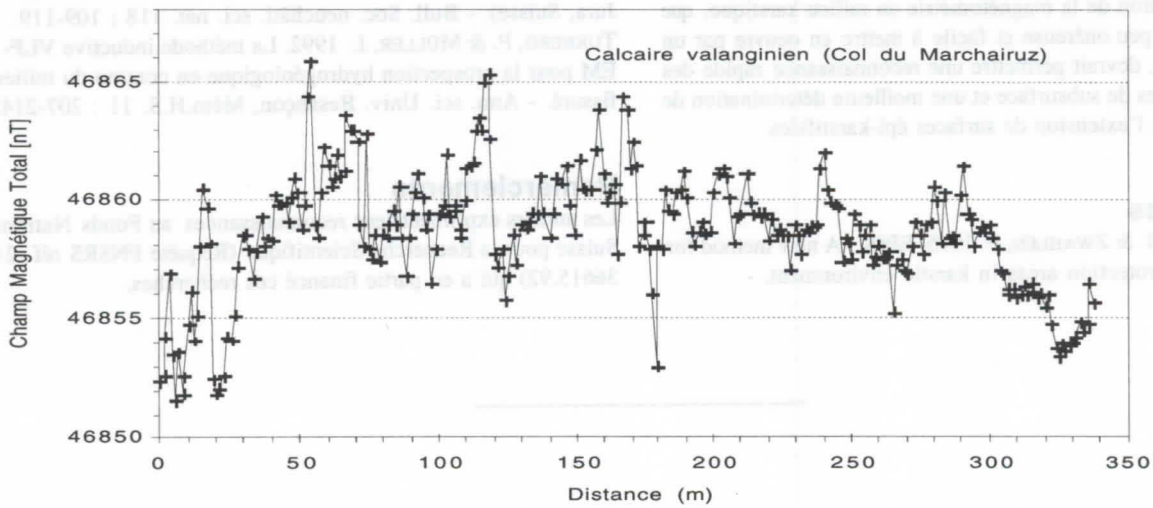

Fig. 3: Profil magnétique (champ total) sur une zone fracturée et karstifiée du Valanginien (Marchairuz, canton de Vaud, Suisse).

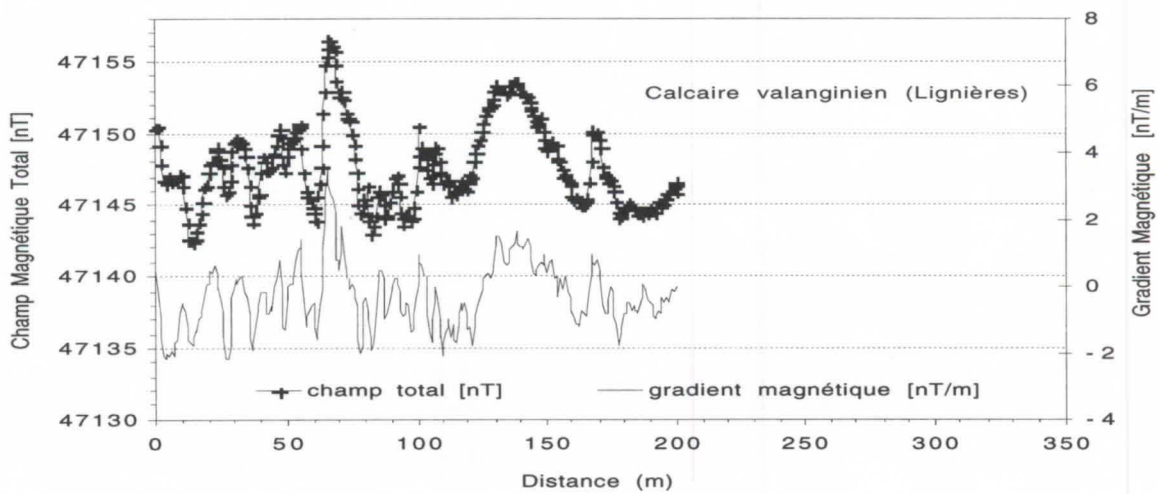

Fig. 4: Profil magnétique (champ total et gradient) sur une zone fracturée et karstifiée du Valanginien (Lignièrès, canton de Neuchâtel, Suisse).

4. Discussion et Conclusion

Sur la base d'essais préliminaires, il s'avère que la mesure magnétométrique "en continu" peut être utilisée en milieu calcaire jurassien pour la détection des zones fracturées. Ces dernières sont en effet fréquemment remplies de matériel détritique susceptible d'influencer le champ magnétique total. Par cette méthode, la mise en évidence de différents types de fracturation ou de karstification, p. ex. liés à différents types de formations géologiques, est également envisagée.

Il faut toutefois noter que les dépôts quaternaires détectés par magnétométrie contribuent à colmater les fractures, donc à diminuer leur perméabilité. Pour que la magnétométrie soit utilisable, il faut alors considérer les zones d'anomalie comme des zones d'altération préférentielle où la probabilité de trouver des volumes perméables est plus forte que dans les zones dépourvues d'anomalie magnétique. A l'heure actuelle, l'évaluation du degré de colmatage d'une zone fracturée reste encore hors de portée des méthodes géophysiques de surface.

Il nous apparaît néanmoins, après deux années d'expérience dans l'application de la magnétométrie au milieu karstique, que cette méthode peu onéreuse et facile à mettre en oeuvre par un seul opérateur, devrait permettre une reconnaissance rapide des zones fracturées de subsurface et une meilleure détermination de la nature et de l'extension de surfaces épi-karstifiées.

Références

DOERFLIGER, N. & ZWAHLEN, F. 1995. EPIK : A new method for outlining of protection areas in karstic environment. -

Proceedings Internat. Symp. on karst groundwater. Antalia nov. 1995 (In press).

DOERFLIGER, N. 1996. Advances in karstic groundwater protection strategy using tracing tests analysis and multiattribute vulnerability mapping (EPIK method). - Thèse Univ. Neuchâtel. (In press).

MANGIN, A. 1975. Contribution à l'étude hydrodynamique des aquifères karstiques. Troisième partie.- Constitution et fonctionnement des aquifères karstiques. Ann. Spéléo. 30, 1:21-124.

MILSON, J. 1992. Field geophysics. geological Society of London Handbook. John Wiley & Sons. New York.

MÜLLER, I. 1982. Première prospection électromagnétique VLF (Very Low Frequency) dans le karst en Suisse. Actes Congr. nat. spéléol. 24-26 sept. 1982 Schwyz : 173-181.

MÜLLER, I. et al., 1995. Réflexions sur les résultats obtenus par l'enregistrement en continu des paramètres géophysiques, électromagnétiques (VLF-EM) et magnétiques, pour l'exploration des aquifères karstiques (Grotte de Milandre, Jura, Suisse). - Bull. Soc. neuchâtl. sci. nat. 118 : 109-119.

TURBERG, P. & MÜLLER, I. 1992. La méthode inductive VLF-EM pour la prospection hydrogéologique en continu du milieu fissuré. - Ann. sci. Univ. Besançon, Mém.H.S. 11 : 207-214.

Remerciements

Les auteurs expriment leur reconnaissances au Fonds National Suisse pour la Recherche Scientifique (Requête FNSRS réf. 21-36615.92) qui a en partie financé ces recherches.

Drainage karstique de la chaîne calcaire du Djurdjura (Grande Kabylie, Algérie). Alimentation et interaction entre composantes évaporitique et carbonatée

Malek Abdesselam *, Hocine Lami *, Jacky Mania **, Jacques Mudry **, Aigoun C. * & Pierre Chauve **

* Université de Tizi Ouzou, Route de Hasnaoua 15000 Tizi Ouzou, Algérie

* Université de Franche-Comté, Laboratoire de Géologie Appliquée, 1 place Leclerc 25000 Besançon, France

Résumé

Le Djurdjura, dominé par les puissantes barres calcaires du Lias inférieur, est un empilement d'écaillles N70, découpées par des accidents N140. Les unités hydrogéologiques forment des bandes longitudinales est-ouest limitées au sud par les flyschs et le trias imperméable et au nord par le socle kabyle, les marnes du Miocène et un cône fluvial. La karstification ancienne (grottes perchées...), l'enfoncement vertical des circulations et leur drainage vers l'ouest traduisent l'exhaussement du massif (mouvements post-villafranchiens) responsable du climat "périglacière méditerranéen" auquel il est soumis (gélifraction, dissolution ...).

Les analyses isotopiques montrent un gradient altitudinal des teneurs en tritium (+0,22 UT par 100 m) et en oxygène-18 (-0,37 ‰ par 100 m), couplé à un gradient pluviométrique de +60 mm/100 m. L'excès en deutérium par rapport à la droite météorologique mondiale est imputable à des apports pluvieux de l'est méditerranéen. Les influences européennes ou sahariennes sont également mises en évidence.

Une typologie de l'alimentation des émergences a été proposée à partir du traçage isotopique naturel de la molécule d'eau (altitude des impluviums) et des faciès chimiques rencontrés : émergences de l'épikarst (bicarbonaté calcique) et participation d'une composante triasique (chloruré sodique).

Abstract

The Djurdjura, dominated by the lower Liassic thick and massive limestones layers is a pile of N70 trending thrust sheets which are cut by N140 faults. The hydrogeological units form est-west longitudinal bands which are limited by flyschs and impermeable Triassic layers in the south and by the Kabylean basement, Miocene marls and a fluvial cone in the north. The old karstification (hanging caves), the vertical deepening of waterflows and their drainage to westwards reflect the uplift of the massif (post-Villafranchian movements) which is responsible for its 'periglacial mediterranean' climate (gelivation, dissolution ...).

The isotopic analyses show an altitudinal gradient of tritium (+0,22 UT per 100 m) and oxygen-18 (-0,37 ‰ per 100 m), coupled with a rain gradient of +60 mm per 100 m. The deuterium excess versus the world meteorological line is due to eastern-mediterranean precipitations. The European or Saharian influences are also demonstrated.

A typology for alimentation of emergences is proposed by the means of natural isotopic tracing of water molecule (altitude of intake area), and hydrochemical facies : epikarst springs (calcic and bicarbonated type) and participation of a Triassic component (sodium chloride type).

1. Présentation générale

La chaîne calcaire du Djurdjura se situe au nord de l'Algérie, à 100 km à l'est d'Alger et à moins de 50 km au sud du littoral méditerranéen (Fig. 1). C'est une chaîne de montagnes récente fortement soulevée avec des versants à la verticale de plus de 1000 m de dénivelée. Elle s'étend selon une direction E-W sur environ 50 km. Sa largeur est très réduite (entre 1 et 10 km). L'altitude des crêtes oscille entre 1200 et 2308 m, (point culminant Tamgout Lalla Khedidja). Cette disposition lui donne l'allure d'une muraille haute avec des arêtes rigides et déchiquetées. Elle domine la grande dépression de Mechtras-Boghni-Dra El Mizan vers le Nord.

Le Djurdjura, par sa position, son altitude, ses importantes précipitations, ses sommets enneigés plusieurs mois chaque année et par l'absence d'activité humaine (sans habitations ni agriculture) est considéré comme une importante réserve d'eau. Il peut constituer une région de référence pour la qualité des eaux de pluie, des sources et des rivières.

Nous ferons ici la présentation de la structure et du fonctionnement d'un karst de montagne en zone méditerranéenne où l'alimentation par la neige et les structures conditionnent les écoulements.

2. Contexte géologique et géomorphologique

Le Djurdjura, est formé par un ensemble de dorsales, sous forme d'unités structurales de direction est-ouest, à plans axiaux redressés et déversés vers le Sud. Il est encadré par le socle cristallin et cristallophyllien de Grande Kabylie au Nord et par les flyschs qu'il chevauche à sa limite méridionale. Il est constituée par un ensemble sédimentaire allant du Paléozoïque supérieur au Cénozoïque où les calcaires massifs du Lias inférieur et de l'Eocène sont dominants. Ces

derniers sont redressés à la verticale par la néotectonique. Les autres ensembles sont formés, pour le Trias, de grès, argiles et gypse (non reconnu en surface) et de marno-calcaires essentiellement, pour le reste de la série.

Les terrains tendres forment de profondes vallées entre les grandes masses calcaires. Des talus d'éboulis, des glaciers rocheux et des cônes de déjections quaternaires s'étalent à la base des pentes.

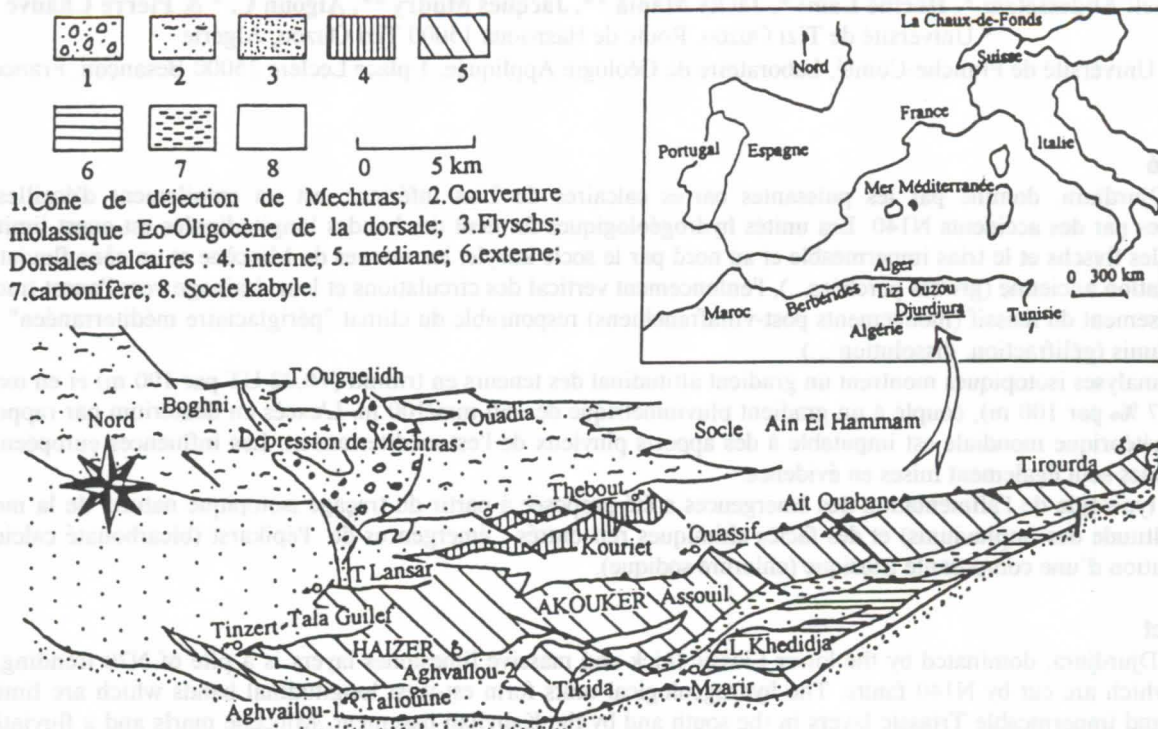

Figure 1 : Situation et contexte géologique du Djurdjura, et position des sources (d'après Naak, 1988).

Le Djurdjura est un karst de type haut-alpin supraforestier. Il est soumis à un climat "périglacière de montagne méditerranéenne". Les précipitations (près de 2000 mm/an) sont dominées par la neige (75 % sur les sommets). La couverture neigeuse dure plus de 5 mois de fin novembre à fin avril-mai.

La grande densité des formes karstiques de surface, l'intense fracturation et les fissures ouvertes par la décompression, favorisent l'infiltration d'une grande proportion des précipitations (75 %) en particulier dans les dolines, les couloirs karstiques (agouni) et les puits verticaux (tesserefts). La fonte de la neige fournit des débits comparables à celui de pertes massives et assure l'alimentation des réseaux. Au cours des traçages réalisés sur l'Haïzer (Abdesselam, 1990 et 1995), le débit au point d'injection était de l'ordre de 11/s alors qu'il était supérieur à 1 m³/s à la source de Tinzert.

Le fort relief et la structure géologique conditionnent des circulations verticales avec de forts gradients hydrauliques. L'abaissement d'axe vers l'Ouest est recoupé par les accidents de direction N40 et N140. Les principales émergences se situent généralement aux extrémités ouest des unités structurales qu'elles drainent aux points les plus bas. Les expériences de traçage ont permis de montrer les relations entre les massifs et les émergences (Birebent, 1948; Collignon 1981; Abdesselam 1990 et alt et 1995). On retrouve les sources de Tinzert, Mendes, Thebout et Mzarir à l'extrémité ouest des massifs de l'Haïzer, Azerou Bouarous, Ait Yerene et Lalla Khedidja respectivement. Dans la partie orientale de la chaîne, la dorsale médiane est drainée vers l'est (Ait Ouabane) au contact avec les schistes du socle kabyle. L'absence de relations transversales entre les différentes unités structurales, a également été mise en évidence: elles constituent des unités de drainage indépendantes. Les niveaux imperméables, formés par les marnes et argiles du Trias, du Jurassique supérieur et du Crétacé et les flyschs, forment le mur des aquifères.

Le débit spécifique est supérieur à 37 l/s/km² (37,1 à Tinzert, 37 à Mzarir et 40,7 l/s/km² à Souk Djema) soit un rendement de plus de 1,1 million de m³/km².

3. Apports des isotopes

Les analyses isotopiques sur les eaux des pluies, montrent un gradient altitudinal des teneurs en tritium (+0,22 UT par 100 m) et en oxygène-18 (-0,37‰ par 100 m), couplé à un gradient pluviométrique de +60 mm/100 m. Nous avons pu ainsi reconnaître les zones d'alimentation des sources (fig 2) et le cheminement des eaux. Ces circulations souterraines sont représentées sur la figure 3.

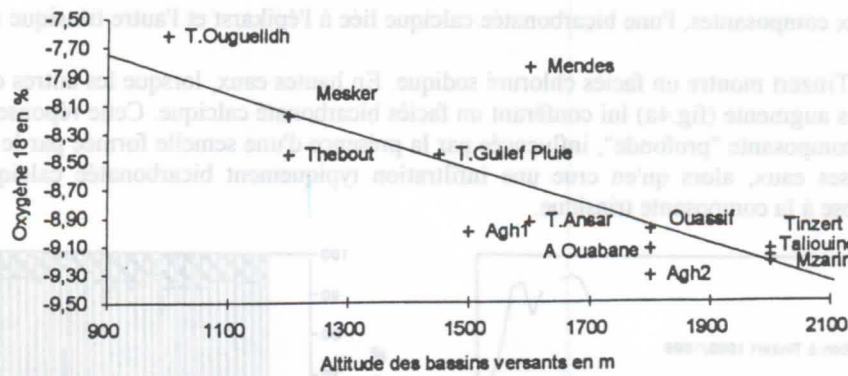

Figure 2 : Répartition des teneurs en oxygène 18 des eaux de sources avec l'altitude des bassins versants.

On distingue des groupes d'émergences selon leur appartenance aux différentes unités structurales et l'altitude de leur bassin d'alimentation. Tinzert, Taliouine, Aghvailou-2, Ait Ouabane, Ouassif et Mzarir forment un premier groupe à impluvium élevé. Le deuxième ensemble regroupe les sources Thebout, Tabourt Lansar, T.Oughelidh et Mesker. L'altitude de ces émergences est plus faible, ainsi que leurs bassins versants.

Tala Oughelidh présente les valeurs les plus fortes et émerge à l'altitude la plus basse. Son alimentation est à la fois assurée par les précipitations directes à basse altitude et les infiltrations venant de la vidange des karsts à l'amont (fig.3).

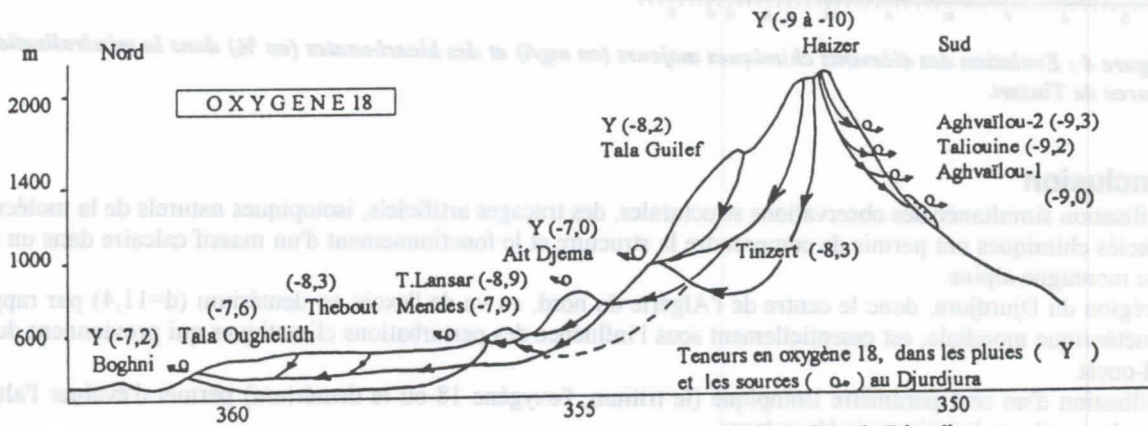

Figure 3 : Alimentation et circulations des eaux souterraines dans le Djurdjura

Les teneurs en deutérium, malgré le peu de mesures réalisées (eaux des sources et un seul échantillon de pluie à Tala Guilef à 1450m d'altitude) donnent la même information que l'oxygène 18.

Le Tritium donne la même répartition des sources. Les teneurs en Tritium des sources sont proches de celles des précipitations. La similitude de ces teneurs indique que les eaux aux émergences sont récentes et datent des épisodes pluvieux de la saison ou tout au moins de l'année.

La relation oxygène18 / deutérium (sur les eaux des sources) forme une droite d'équation proche de celle des précipitations mondiales : $d \ 2 \ H = 7,1 \ d \ 18O + 11,4$

L'excès en deutérium ($d = 11,4$) par rapport à la droite météorique mondiale est imputable à des apports pluvieux de l'est méditerranéen ($d = 14,5$ Latium-Italie; $d = 13,4$ Alexandrie-Egypte, Fontes, 1976). L'influence des perturbations liées aux masses d'air océanique arrivant par le Nord-Ouest et celles descendant de la mer du Nord et passant par la France est prépondérante (expliquant l'importance des neiges).

5. Mise en évidence de deux composantes hydrochimiques

L'examen des variations des éléments chimiques sur des diagrammes séquentiels montre le caractère dilué (en hautes eaux) et concentré en basses eaux, ou à l'avant des crues (effet de chasse). A la source de Tinzert, les concentrations en Ca^{++} et HCO_3^{--} (exprimées en mg/l) sont relativement constantes (fig. 4a). En revanche leur pourcentage, à chaque instant, dans les minéralisations s'apparente à l'hydrogramme de la source. Leur part augmente en hautes eaux, à la suite de la dilution des autres éléments (Cl^- , Na^+ , SO_4^{--} , Mg^{++} et K^+). Le faciès de l'eau change et devient bicarbonaté calcique franc. Elle diminue en basses eaux pendant que les autres éléments augmentent. On distingue ainsi nettement la

participation de deux composantes, l'une bicarbonatée calcique liée à l'épikarst et l'autre triasique avec un faciès chloruré sodique.

En basses eaux, Tinzert montre un faciès chloruré sodique. En hautes eaux, lorsque les autres éléments sont dilués, la part des bicarbonates augmente (fig.4a) lui conférant un faciès bicarbonaté calcique. Cette réponse chimique démontre la participation d'une composante "profonde", influencée par la présence d'une semelle formée par le Trias salifère. Ceci est bien visible en basses eaux, alors qu'en crue une infiltration typiquement bicarbonatée calcique, en provenance de l'épikarst se surimpose à la composante triasique.

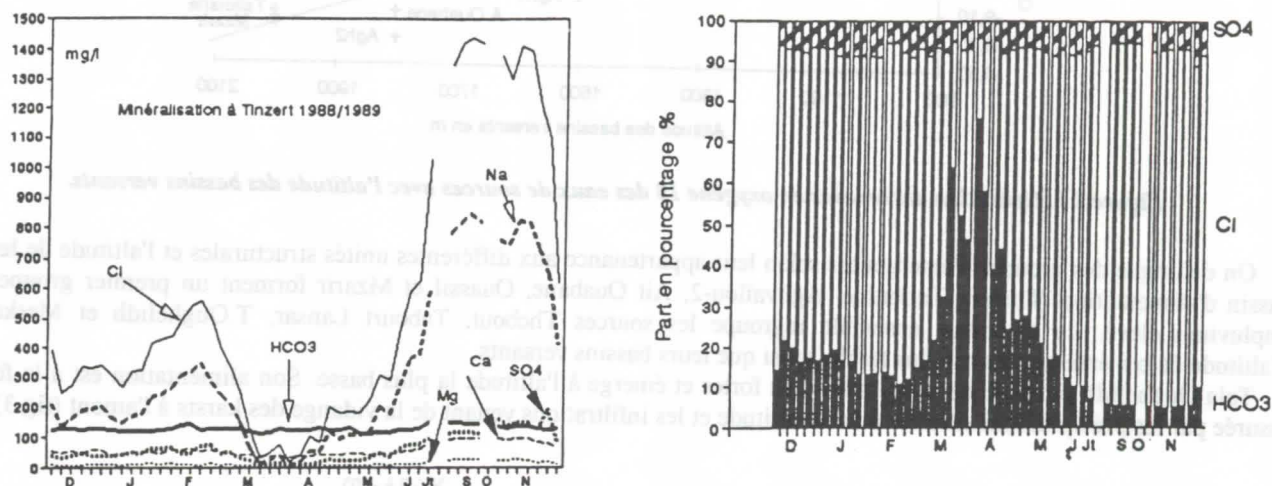

Figure 4 : Evolution des éléments chimiques majeurs (en mg/l) et des bicarbonates (en %) dans la minéralisation à la source de Tinzert.

6. Conclusion

L'utilisation simultanée des observations structurales, des traçages artificiels, isotopiques naturels de la molécule d'eau et des faciès chimiques ont permis de comprendre la structure et le fonctionnement d'un massif calcaire dans un contexte de haute montagne alpine.

La région du Djurdjura, donc le centre de l'Algérie du nord, au vu de l'excès en deutérium ($d=11,4$) par rapport à la droite météorologique mondiale, est essentiellement sous l'influence des perturbations climatiques qui proviennent du nord et du nord-ouest.

L'utilisation d'un seul paramètre isotopique (le tritium, l'oxygène 18 ou le deutérium) permet d'évaluer l'altitude de recharge des systèmes karstiques indépendants.

Dans le Djurdjura, l'alimentation est assurée par les hauts reliefs. Le drainage karstique est guidé par la structure de la chaîne sous de forts gradients hydrauliques. Le tritium montre que la vidange est rapide. On y distingue une composante bicarbonatée calcique liée à l'épikarst constituant l'essentiel de l'écoulement, mais visible seulement en hautes eaux, et une composante chlorurée sodique liée à une semelle triasique qui limite le karst noyé en profondeur.

Références :

- ABDESSELAM, M. 1995. Structure et fonctionnement d'un karst de montagne sous climat méditerranéen : exemple du Djurdjura occidental (Grande Kabylie Algérie). Thèse Univ. Franche-Comté, Besançon, 237p.
- ABDESSELAM, M., LAMI, H., MANIA, J., CHAUVE, P. & BROQUET, P. 1988. Etude de l'aquifère karstique du Djurdjura (Algérie). Coll. Hydrologie en pays calcaire. 29-30 sept. Besançon, France. Ann. Scient. Univ. de Besançon, mémoire hors série, 6: 229-236.
- ABDESSELAM M., LAMI, H. & MANIA, J. 1990. Le Djurdjura, aquifère karstique de montagne de type alpin (Algérie). Inter. Conf. on Water resources in mountainous regions. 27 Aout-1 sept. Lausanne, Suisse. Mémoires of the 22nd Congress of IAH, 22: 434-443.
- COLLIGNON, B. & MAIRE, R. 1984. Le massif du Djurdjura. Eléments de synthèse sur l'hydrogéologie et la spéléogénèse. Spelunca 15: 1-10.
- MUDRY, J., BLAVOUX, B., DRAY, M. & VUYLSTEEK, G. 1990. Différentiation du fonctionnement hydrodynamique de deux sources du massif karstique du Niffion (Haute Savoie) à partir des données physico-chimiques et isotopiques. Internat. Conf. on Water resources in mountainous regions. 27 Aout-1 sept. Lausanne, Suisse. Mémoires of the 22nd Congress of IAH, 22: 375-382.
- NAAK, M. 1988. Etude géologique de la dorsale interne du Djurdjura. Interprétation généralisée à l'ensemble de la chaîne et proposition d'un modèle d'évolution géodynamique de ce tronçon de la paléomarge continentale kabyle. Thèse magister, Univ. Alger, 145 p.
- QUINIF, Y. 1976. Contribution à l'étude morphologique des karsts algériens de type haut-alpin. Rev. Géog. Phys. Géol. Dynam. 18(1): 5-18.

Utilisation des traceurs météoriques (Cl^- , ^{18}O) à l'étude des aquifères carbonatés des sierras Blanca et Mijas (Cordillère Bétique, Sud de l'Espagne)

Andreo B. (1), Mudry J. (2), Carrasco F. (1) et Vadillo I. (1)

(1) Departamento de Geología, Facultad de Ciencias, Universidad de Málaga - E-29071 MALAGA

(2) Laboratoire de Géologie Structurale et Appliquée, Université de Franche-Comté, Place Leclerc F-25000 BESANCON

Résumé

D'octobre 1990 à mars 1993, 128 échantillons d'eau de pluie prélevés sur les sierras Blanca et Mijas, une unité formée de marbres triasiques, située sur la Costa del Sol (Málaga, Espagne) ont fait l'objet de mesures de teneurs en chlorures, et 28 d'entre elles d' ^{18}O . Les chlorures de 48 échantillons d'eaux souterraines prélevées au printemps 1991 ont également été analysés, ainsi que l' ^{18}O de 33.

Les eaux de pluie tombées sur les sierras ont majoritairement un faciès bicarbonaté calciques ou chloruré sodique, parfois un faciès mixte. La conductivité moyenne pondérée de la conductivité de la pluie est de $70 \mu\text{S}/\text{cm}$ et les teneurs moyennes de chlorures et d'oxygène-18 sont respectivement de 7 mg/l et de $-5,50 \text{ ‰}$. La corrélation linéaire entre ces teneurs et variables géographiques est peu significative, quoique l'on puisse dire que dans le secteur occidental de la sierra Blanca, où il pleut plus, les eaux de pluie sont plus pauvres en Cl^- et ^{18}O que dans la sierra Mijas, moins arrosée.

Les eaux souterraines du secteur d'étude ont un faciès bicarbonaté calcique et calco-magnésien, avec une conductivité moyenne de l'ordre de $400 \mu\text{S}/\text{cm}$. Les teneurs moyennes en Cl^- et ^{18}O sont $14,6 \text{ mg/l}$ et $-6,25 \text{ ‰}$. La corrélation entre traceurs météoriques et variables géographiques n'est pas plus significative. À l'échelle de l'unité étudiée, les teneurs en Cl^- et ^{18}O des eaux souterraines sont plus basses dans le secteur occidental de la sierra Blanca que dans la sierra Mijas, comme dans la pluie. Dans le secteur oriental de la sierra Blanca, les teneurs sont plus faibles que dans le secteur occidental, grâce à l'effet-barrière exercé par les reliefs de la sierra Canucha à l'ouest et de la sierra Alpujata au sud. De plus, les eaux de source de la partie méridionale ont des teneurs semblables à celles de la sierra Mijas, à cause de la proximité de la mer. Tout cela, ajouté aux données géologiques et hydrogéologiques permet la délimitation des aires de recharge des différents aquifères.

L'étude des traceurs météoriques permet de conclure que les eaux souterraines échantillonnées au printemps 1991 proviennent de fronts pluvieux d'origine atlantique, qui suivent une direction SW-NE. La composition chimique et isotopique des eaux de pluie correspond à la situation géographique de l'unité entre l'Atlantique et la Méditerranée, mais surtout à l'orographie de la région. On peut conclure de plus qu'à l'échelle de l'unité Blanca-Mijas, il n'existe pas de gradient altitudinal de teneurs de traceurs météoriques.

Abstract

From October 1990 to March 93, 128 rain waters were sampled on the Blanca and Mijas sierras, a unit made of triassic marbles, situated on the Costa del Sol (Málaga, Spain). On all these samples, chloride was analyzed, and on 28 of them, ^{18}O . Chloride of 48 groundwater samples and ^{18}O of 33 of them, taken in spring 1991 were also analyzed.

The rain waters which fall on the sierras, are mainly of a calcium bicarbonate or sodium chloride type (sometimes mixed). The average weighted specific conductance of the rain is $67 \mu\text{S}/\text{cm}$ and the average contents of Cl^- and ^{18}O are respectively $14,6 \text{ mg/l}$ and $-5,50 \text{ ‰}$. The lineal correlation between these contents and the geographic variables is poorly significant, though it may be said that in the occidental sector of sierra Blanca, where it rains more, rain waters are often poorer in Cl^- and ^{18}O than in the less watered sierra Mijas.

The groundwaters of the study area are of a calcium bicarbonate or calcium and magnesium type, with an average specific conductance of about $400 \mu\text{S}/\text{cm}$. The average Cl^- and ^{18}O contents are $14,7 \text{ mg/l}$ and $-6,24 \text{ ‰}$. The correlation between the meteoric tracers and the geographic variables is not more significant. At the scale of the studied unit, Cl^- and ^{18}O contents of the groundwaters are lower in the western part of sierra Blanca than in sierra Mijas, as in the rain. In the eastern part of sierra Blanca, the contents are lower than in the western part, because of the barrier effect imposed by the reliefs of sierra Canucha westwards and sierra Alpujata, southwards. In addition, the spring waters of the southern part have similar contents to sierra Mijas', because of the proximity of the sea. All this, added to the geological and hydrogeological data enable us to delineate the recharge areas of the different aquifers.

Through the study of meteoric tracers, we can conclude that the groundwaters which were sampled in the spring of 1991 come from weather systems of an Atlantic origin, following a SW-NE direction. The chemical and isotopical composition of the rain water corresponds to the geographical situation of the unit, between the Atlantic ocean and the Mediterranean sea, but especially to the orography of the region. It all boils down to saying that at the scale of the Blanca Mijas unit, there is no altitudinal gradient of meteoric tracers.

1. Introduction

Les sierras Blanca et Mijas forment une partie de la chaîne montagneuse qui limite au nord la Costa del Sol (Sud de l'Espagne). Situées entre les villes de Torremolinos à l'E et Marbella à l'W (figure 1) et à moins de 5 km de distance moyenne de la Mer méditerranée, elles sont séparées par le Puerto de los Pescadores (300 m). Leurs points culminants sont le Cerro del Lastonar (1270 m) dans la sierra Blanca et le Vértice Mijas (1150 m).

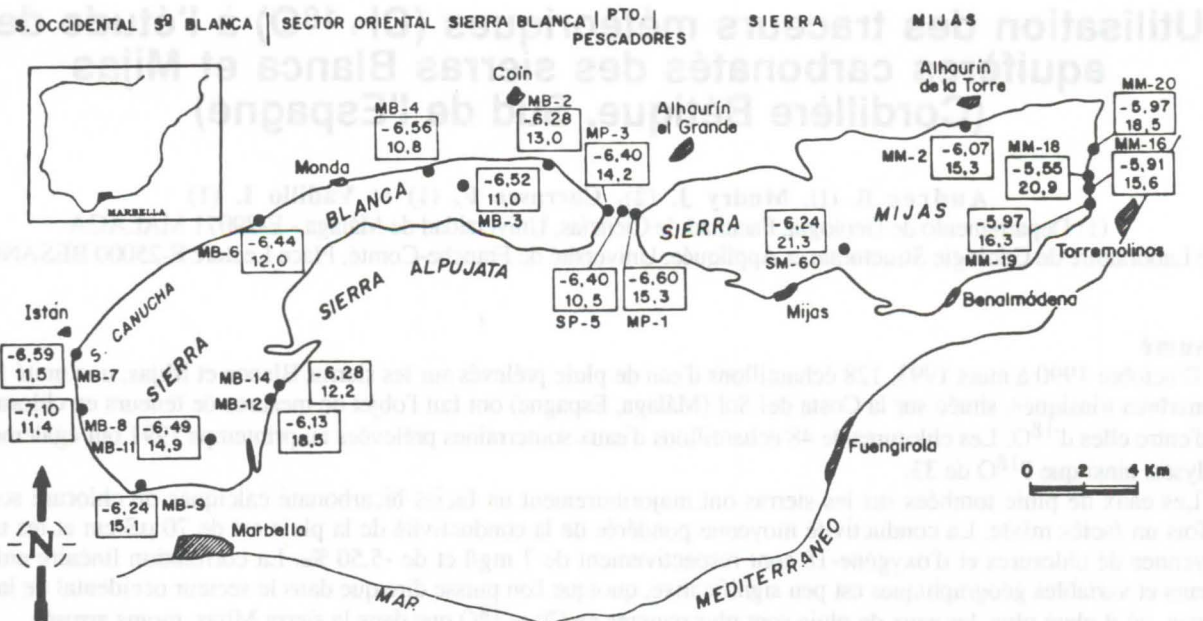

Les cartouches représentent les teneurs en chlorures et en oxygène-18 des émergences karstiques au printemps 1991.

Figure 1 : Localisation géographique des sierras Blanca et Mijas.

D'un point de vue géologique, elles forment une partie du complexe Alpujárride des Cordillères bétiques. La série stratigraphique est formée par un ensemble inférieur métapélitique (migmatites et gneiss paléozoïques) et par un ensemble supérieur carbonaté (marbres triasiques) puissant de 600 m, subdivisible en deux séries bien distinctes (ANDREO, 1996) : la série inférieure formée de marbres blancs dolomitiques et la série supérieure de marbres calcaires bleus.

Les marbres blancs sont plus diaclasés, mais peu karstifiés. Dans les lieux où ils affleurent, ils donnent des reliefs à faible pente comme dans la sierra Mijas et surtout dans la partie orientale de la sierra Blanca, où se développent des formes exokarstiques appelées "llanos" (zones topographiquement déprimées). Les marbres bleus sont moins diaclasés, mais présentent une karstification plus développée (ANDREO *et al.*, 1996), ils donnent des reliefs plus accidentés comme dans la partie occidentale de la Sierra Blanca.

Les sierras Blanca et Mijas constituent une unité hydrogéologique, de 170 km² de surface, leurs ressources moyennes sont de l'ordre de 50 hm³/an, alors que les sorties moyennes sont supérieures (60 hm³/an), à cause de l'intense exploitation dont fait l'objet la sierra Mijas, pour l'alimentation de la zone touristique. Dans ce travail, nous étudions la distribution des teneurs en traceurs météoriques (Cl⁻ et ¹⁸O), dans les eaux de pluie et dans les eaux souterraines de l'unité Blanca-Mijas (figure 1). Cette méthodologie est appliquée dans le but initial de déterminer les altitudes de recharge des systèmes aquifères (MUDRY, 1981; BLAVOUX & MUDRY, 1990; LASTENNET, 1994), et de calculer l'infiltration efficace en fonction de l'altitude de recharge (CARDENAL *et al.*, 1994)

2. Pluviosité et traceurs météoriques dans les eaux de pluie

Les précipitations annuelles sur les sierras Blanca et Mijas, sur la chronique 1963/64 - 1993/94, varie de 750 mm à la station d'Ojén à 610 à Torremolinos, avec une valeur moyenne de 670 mm. Au niveau de l'aire étudiée, de même qu'à l'échelle de l'Andalousie, les précipitations diminuent d'ouest en est, c'est-à-dire que la pluviosité diminue quand augmente la distance à l'Atlantique, d'où proviennent les perturbations.

Des corrélations ont été effectuées entre la hauteur d'eau et les trois variables géographiques dont on peut supposer l'influence sur la répartition : distance à Istán (ou à l'Atlantique : longitude), altitude, distance à la Méditerranée (latitude). Les valeurs les plus élevées du coefficient de corrélation s'observent pour la corrélation avec la longitude et, dans une moindre mesure, l'altitude (ANDREO, 1996).

D'octobre 1990 à mars 1993, 128 échantillons d'eau de pluie ont été recueillis, et les chlorures analysés. Sur 41 échantillons d'eau, les éléments majeurs ont été analysés, et sur 28 la teneur en ¹⁸O. La conductivité moyenne pondérée de la pluie est 70 µS/cm et les faciès les plus fréquents sont bicarbonaté calcique et chloruré sodique, ce dernier type étant plus fréquent dans la sierra Mijas (ANDREO, 1996). La moyenne pondérée est 7 mg/l pour les teneurs en chlorures et -5,5‰ pour celles en oxygène-18. Les coefficients des corrélations linéaires entre ces teneurs et les variables géographiques sont tous bas, les moins bas étant avec l'altitude et la distance à Istán. Seule la corrélation teneur en chlorures-altitude peut être considérée comme significative, le gradient calculé est -0,9 mg/l / 100m de dénivelée. Les corrélations avec la distance à Istán se manifestent seulement par un accroissement des teneurs en composantes météoriques avec cette distance : dans le secteur occidental de la sierra Blanca, où il pleut plus, les teneurs sont plus basses que dans la sierra Mijas.

Les faibles coefficients de corrélation observés peuvent provenir en partie de la mauvaise représentativité des échantillons analysés. Cependant, d'autres facteurs peuvent être invoqués : arrivée des perturbations par le Nord ou le Sud de la Péninsule ibérique, configuration du relief (sierras Blanca, Canucha, Alpujata et Mijas) induisant un "effet d'ombre".

3. Traceurs météoriques dans les eaux souterraines

Pendant les mois de printemps 1991, 46 échantillons ont été pris sur les principaux points d'eau, pour l'analyse des éléments majeurs (dont les chlorures); et pour 23 d'entre eux de la teneur en ^{18}O . La conductivité moyenne est $400 \mu\text{S}/\text{cm}$, la teneur en chlorures $14,6 \text{ mg}/\text{l}$ et celle en ^{18}O $-6,25 \text{ ‰}$, le faciès est bicarbonaté calcique à calco-magnésien selon le secteur (ANDREO, 1996). La corrélation avec les variables géographiques a été tentée.

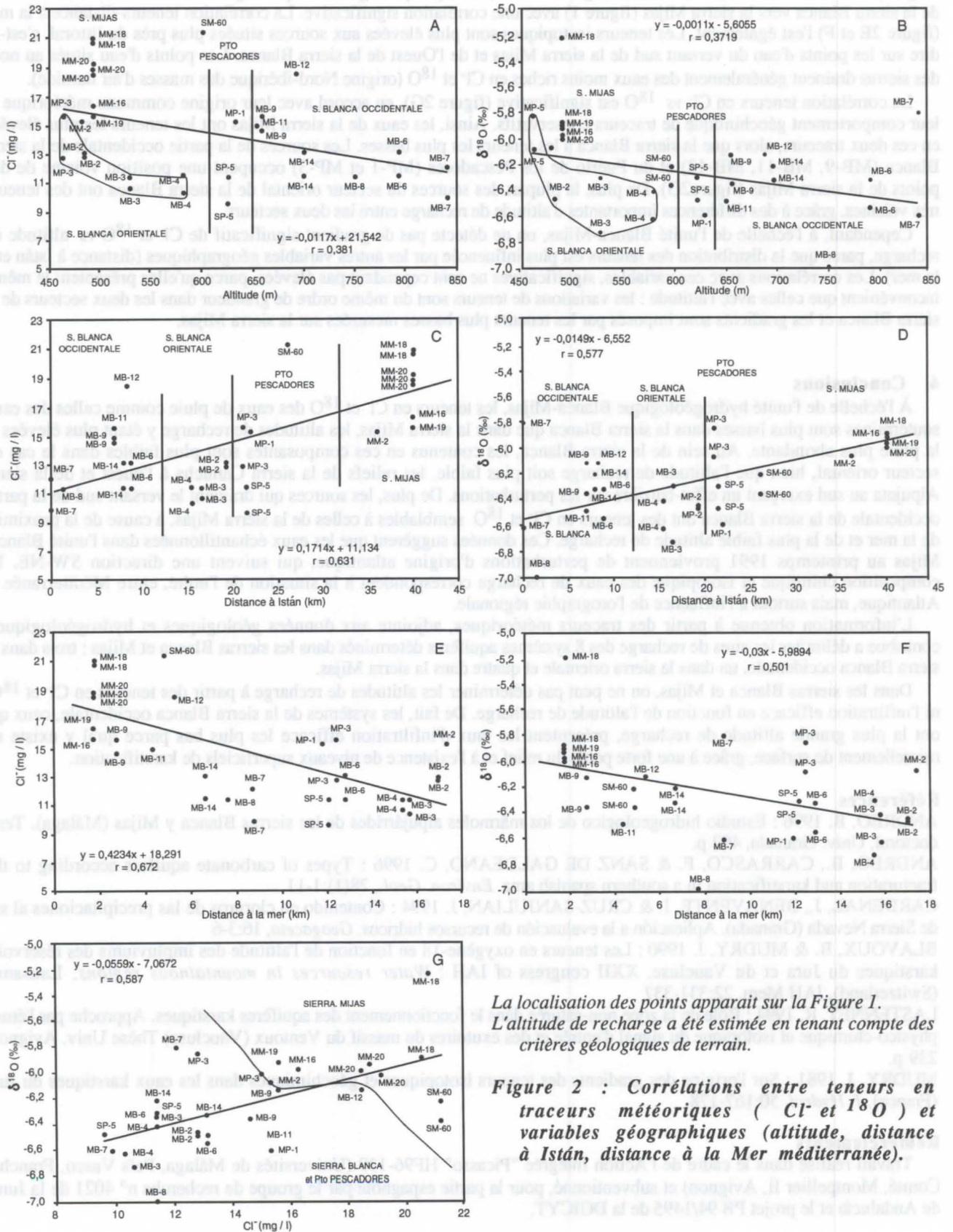

La localisation des points apparaît sur la Figure 1.
L'altitude de recharge a été estimée en tenant compte des critères géologiques de terrain.

Figure 2 : Corrélations entre teneurs en traceurs météoriques (Cl⁻ et ^{18}O) et variables géographiques (altitude, distance à Istán, distance à la Mer méditerranée).

Le diagramme ^{18}O et Cl^- en fonction de l'altitude (figure 2A et B) permet de constater, en général, que les sources de la sierra Mijas, dont les altitudes de recharge sont plus basses, ont les teneurs les plus élevées, alors que l'on observe le contraire dans la sierra Blanca occidentale, où les altitudes de recharge sont plus élevées et les eaux plus négatives en ^{18}O .

Dans le secteur oriental de la sierra Blanca et au Puerto de los Pescadores, les eaux sont plus négatives que le laisserait présupposer leur altitude de recharge : les corrélations teneurs en Cl^- et ^{18}O vs altitude n'y sont pas significatives. Sur le secteur occidental de la sierra Blanca, les sources qui drainent la moitié sud du massif (MB-9, MB-11, MB-12) ont une altitude de recharge plus basse et, en général, montrent des teneurs plus élevées en éléments météoriques (figure 1). Le diagramme Cl^- et ^{18}O vs distance à Istán (figure 2C et D), indique qu'en général il y a augmentation des teneurs de l'ouest de la sierra Blanca vers la sierra Mijas (figure 1) avec une corrélation significative. La corrélation teneurs-distance à la mer (figure 2E et F) l'est également. Les teneurs isotopiques sont plus élevées aux sources situées plus près du littoral, c'est-à-dire sur les points d'eau du versant sud de la sierra Mijas et de l'Ouest de la sierra Blanca. Les points d'eau situés au nord des sierras drainent généralement des eaux moins riches en Cl^- et ^{18}O (origine Nord-ibérique des masses d'air humide).

La corrélation teneurs en Cl^- vs ^{18}O est significative (figure 2G), en accord avec leur origine commune météorique et leur comportement géochimique de traceurs conservatifs. Ainsi, les eaux de la sierra Mijas ont les teneurs les plus élevées en ces deux traceurs, alors que la sierra Blanca a les teneurs les plus basses. Les sources de la partie occidentale de la sierra Blanca (MB-9, MB-11, MB-12) et du Puerto de los Pescadores (MP-1 et MP-3) occupent une position voisine de des points de la sierra Mijas (figure 2G). De plus, la plupart des sources du secteur oriental de la sierra Blanca ont des teneurs très voisines, grâce à des différences importantes d'altitude de recharge entre les deux secteurs.

Cependant, à l'échelle de l'unité Blanca-Mijas, on ne détecte pas de gradient significatif de Cl^- et ^{18}O vs altitude de recharge, parce que la distribution des teneurs est plus influencée par les autres variables géographiques (distance à Istán et à la mer). Les corrélations avec ces variables, significatives ne sont cependant pas élevées, parce qu'elles présentent le même inconvénient que celles avec l'altitude : les variations de teneurs sont du même ordre de grandeur dans les deux secteurs de la sierra Blanca et les gradients sont imposés par les teneurs plus basses mesurées sur la sierra Mijas.

4. Conclusions

À l'échelle de l'unité hydrogéologique Blanca-Mijas, les teneurs en Cl^- et ^{18}O des eaux de pluie comme celles des eaux souterraines sont plus basses dans la sierra Blanca que dans la sierra Mijas, les altitudes de recharge y étant plus élevées et la pluie plus abondante. Au sein de la sierra Blanca, les contenus en ces composantes sont plus faibles dans le cas du secteur oriental, bien que l'altitude de recharge soit plus faible, les reliefs de la sierra Canucha à l'ouest et de la sierra Alpujata au sud exerçant un effet-barrière sur les perturbations. De plus, les sources qui drainent le versant sud de la partie occidentale de la sierra Blanca ont des teneurs en Cl^- et ^{18}O semblables à celles de la sierra Mijas, à cause de la proximité de la mer et de la plus faible altitude de recharge. Ces données suggèrent que les eaux échantillonnées dans l'unité Blanca-Mijas au printemps 1991 proviennent de perturbations d'origine atlantique, qui suivent une direction SW-NE. La composition chimique et isotopique des eaux de recharge correspondent à la situation de l'unité, entre Méditerranée et Atlantique, mais surtout à l'influence de l'orographie régionale.

L'information obtenue à partir des traceurs météoriques, adjointe aux données géologiques et hydrogéologiques, contribue à délimiter les aires de recharge des 8 systèmes aquifères déterminés dans les sierras Blanca et Mijas : trois dans la sierra Blanca occidentale, un dans la sierra orientale et quatre dans la sierra Mijas.

Dans les sierras Blanca et Mijas, on ne peut pas déterminer les altitudes de recharge à partir des teneurs en Cl^- et ^{18}O , ni l'infiltration efficace en fonction de l'altitude de recharge. De fait, les systèmes de la sierra Blanca occidentale, ceux qui ont la plus grande altitude de recharge, présentent les taux d'infiltration efficace les plus bas parce qu'il y existe un ruissellement de surface, grâce à une forte pente du relief et à l'existence de niveaux superficiels de karstification.

Références

- ANDREO, B. 1996 : Estudio hidrogeológico de los mármoles alpujarrides de las sierras Blanca y Mijas (Málaga). Tesis doctoral, Univ. Granada, 492 p.
- ANDREO, B., CARRASCO, F. & SANZ DE GALDEANO, C. 1996 : Types of carbonate aquifers according to the fracturation and karstification in a southern spanish area. *Environ. Geol.*, 28(1):1-11
- CARDENAL, J., BENAVENTE, J. & CRUZ-SANJULIAN, J. 1994 : Contenido en cloruros de las precipitaciones al sur de Sierra Nevada (Granada). Aplicación a la evaluación de recursos hídricos. *Geogaceta*, 16:3-6
- BLAVOUX, B. & MUDRY, J. 1990 : Les teneurs en oxygène-18 en fonction de l'altitude des impluviums des réservoirs karstiques du Jura et du Vaucluse. XXII congress of IAH : *Water resources in mountainous regions*, Lausanne (Switzerland), IAH Mem. 22:331-337
- LASTENNET, R. 1994 : Rôle de la zone non-saturée dans le fonctionnement des aquifères karstiques. Approche par l'étude physico-chimique et isotopique du signal d'entrée et des exutoires du massif du Ventoux (Vaucluse) Thèse Univ. Avignon, 239 p.
- MUDRY, J. 1981 : Sur l'origine des gradients des teneurs isotopiques et géochimiques dans les eaux karstiques du Jura (France). *J. Hydrol.* 50:167-178.

Remerciements

Travail réalisé dans le cadre de l'Action Intégrée "Picasso" HF96-139 (Universités de Málaga, País Vasco, Franche-Comté, Montpellier II, Avignon) et subventionné, pour la partie espagnole par le groupe de recherche n° 4021 de la Junta de Andalucía et le projet PB 94/1495 de la DGICYT.

Karst waters from the region of Bosnek (West Bulgaria): Characteristics and conditions of formation

by **Aleksey Benderev & Stephan Shanov**

Geological Institute, Bulgarian Academy of Sciences, 1113 Sofia, Bulgaria

Abstract

The karst waters in the Triassic limestones from the region near the village of Bosnek (West Bulgaria) have formed two of the biggest Bulgarian caves - Duhlata (more than 17 km of total length of the galleries) and Vreloto (more than 5 km). The lithology of the massif determines the presence of two separated karstic systems. The water conducting channels have been formed following the peculiarities of the systems of joints. Using the statistical approach for analyzing of the conjugated shear joint systems, the kinematic of the deformation along local faults (stria on slickensides, well preserved in the caves), it has been proved that two expressed tectonic stress fields can be reconstructed. The older is aged as Post-Oligocene, the youngest one - as Pliocene-Quaternary, even contemporary. The last deformation determines the general direction of the karst galleries. Practically, this is the way of the underground water flow - from East to West, approximately. For the formation of the underground karst water flow the principal contribution is from the water of Struma river, penetrating in the karst system when attaining the limestone massif. This determines the dynamic regime of the main springs of the area. The water is highly aggressive and, consequently, it has a high potential to dissolve towards the limestones. The changes of the chemical composition of the waters have been traced and, on this base, the evaluation of the karst processes in the area has been done.

Résumé

Les eaux karstiques dans les calcaires du Triassique de la région du village de Bosnek (Bulgarie Occidentale) ont contribué à la formation des unes des plus grande grottes en Bulgarie - Duhlata (la longueur totale des galeries étant plus de 17 km) et Vreloto (plus de 5 km). La lithologie du massif a déterminé l'existence de deux systèmes karstiques séparés. Les chenaux qui ont servi de conducteurs de l'eau s'étaient formés en suivant les particularités du système de fractures. En utilisant une approche statistique dans l'analyse des systèmes conjoints de fractures de cisaillement, la cinématique des déformations le long des failles (des stries sur les miroirs tectonique, très bien préservées dans les grottes), il était démontré qu'il était possible de reconstruire deux champs de tensions tectoniques bien exprimés. L'antérieur est daté de l'âge post-Oligocène et le plus jeune - de l'âge de Pliocène - Quaternaire, même probablement contemporain. La dernière déformation tectonique a prédestiné la direction générale des galeries karstiques. C'est la voie utilisée par les eaux souterraines - de l'Est vers l'Ouest. La contribution principale pour la formation du courant souterrain dans le karst est de provenance de l'eau de la rivière de Strouma qui pénètre dans le système karstique dès que son lit atteint le massif calcaire. Cela détermine le régime dynamique des résurgences principales de la région. L'eau est d'une très haute agressivité chimique et, par suite, elle possède un potentiel élevé de dissolution des calcaires. Les changements de la composition chimique des eaux étaient tracés et sur la base des données obtenues l'évolution des processus de karstification était déterminées.

1. Introduction

The karst region of Bosnek is known with the longest cave in Bulgaria - Duhlata (more than 17000 m). Named after the village of Bosnek, situated at the upper part of Struma river in West Bulgaria, it covers the mountain of Golo Bardo and the southern part of Vitoshka mountain. When started the IGCP Project 299 "Geology, Climate, Hydrology and Karst Formation", the northern part of this karst region, being more or less an independent hydrogeological karst system, was selected as representative for Bulgaria (SHOPOV et al., 1996 - in press). The investigations in the region continued in 1995, when the IGCP Project "Karst Processes and the Carbon Cycle started". The present study, in the frame of this Project is directed to define the geological condition and the hydrogeological situation of formation of the karst and the karst waters in the region of Bosnek. Our own studies have been jointed to the hydrometrical records and the coloration tests performed by the speleologists of the Student Speleological Club of Sofia "Academik" from 1970 to 1995.

2. Geological conditions for the formation of the karst and karst waters

The tectonic position of the Bosnek karst region is totally coinciding with the position of the so called Golo Bardo Unity, interpreted as an sub-Hercynian allochthonous superstructure of Triassic and Jurassic rocks trusted on the Vitoshka Pluton (ZAGORCHEV et al., 1994). The karst and the karst waters have been formed in the Triassic carbonate rocks. The thick massif of limestones and dolomites recover normally the underlying sediments of red-coloured conglomerates and alternating sands and aleurolites of the Lower Triassic (Fig. 1). Inside the carbonate rocks, eastern from the village of

Bosnek, they have been found layers of aleurolites and argillites with a thickness of about 50 m, thus forming a local waterproof and separating the carbonate massif in two parts.

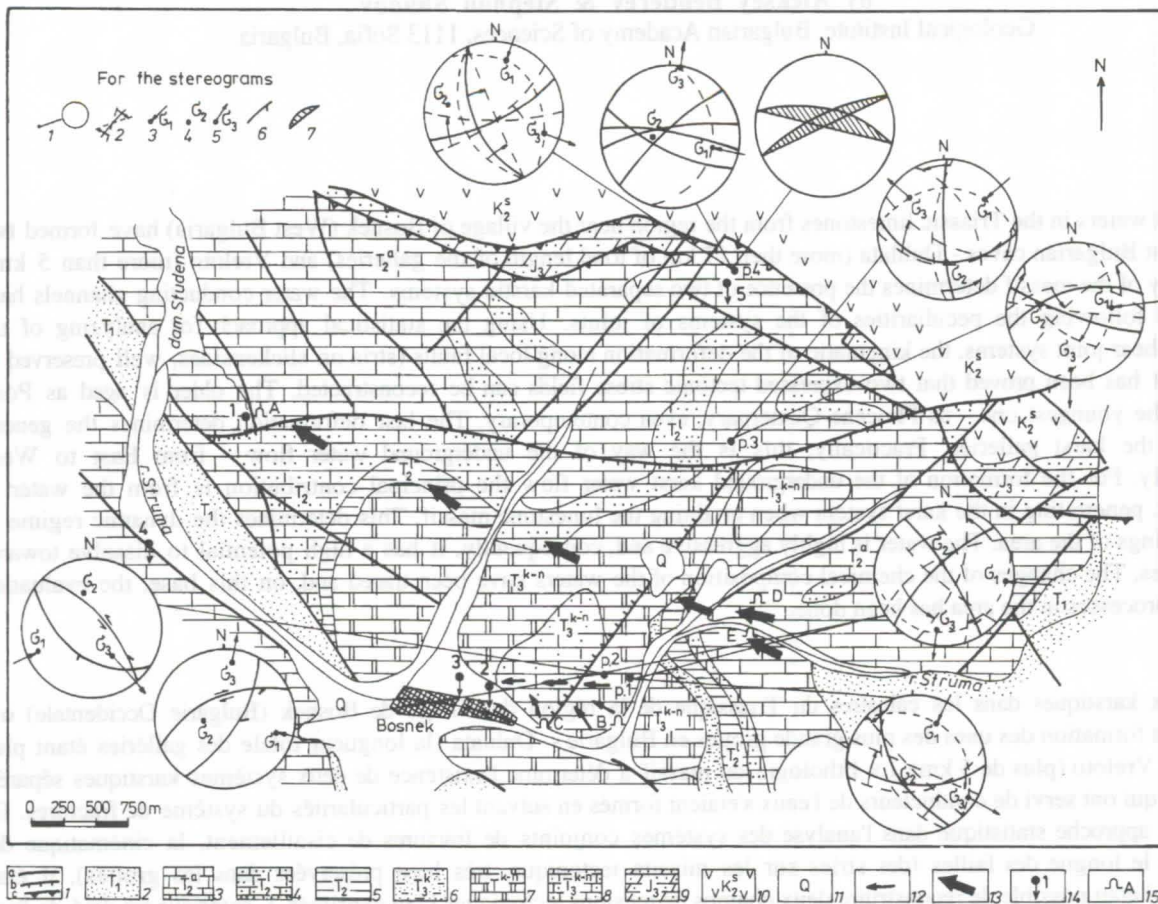

Figure 1. Schema of the geological, tectonic and hydrogeological peculiarities of the karst region of Bosnek

On the schema: 1-Faults (a-with obscure movement, b-normal fault, c-thrust); 2-Sandstone (lower Triassic); 3- Limestones (Anisian); 4-Dolomites (Ladinian); 5-Shales (Ladinian); 6-Limestones (Karnian); 7-Dolomites (Karnian - Norian); 8-Limestones (Karnian - Norian); 9-Silstones and marls (Tithonian); 10-Volcanic rocks (Senonian); 11- Quaternary sediments; 12 -Direction of water flow in karst system Duhlata; 13-Direction of water flow in karst system Vreloto; 14-Springs (1-Vreloto, 2-Dulata, 3-in Bosnek village, 4-Popov Izvor, 5-Zhivata Voda); 15-Caves (A-Vreloto, B -Duhlata, C-Akademik, D-P.P.D., E-Chuchulyan). On the stereograms (upper hemisphere): 1-point of measurement; 2- group of shear joint with dispersion; 3-maximum stress axis; 4-medium stress axis; 5-minimum stress axis; 6-tectonic mirror surface with stria; 7-main open system with development of karst processes.

The tectonic evolution of the structures has led to intensive faulting, dominated by the regional Pernik fault zone (N120-140° direction and about 7 km of width). The zone is presented by set of sub-parallel normal and shear faults, creating a system of grabens and horsts. One of these horsts is the carrier of the mentioned impermeable sediments of the Lower Triassic, cutting the Bosnek karst region in two independent hydrogeological systems. This study concerns the northern part of the system, where the Struma river determine the more active processes of karst formation. The other faults of different orientations are also of importance, contributing to the intensive fracturing of the rocks. The joint systems, perpendicularly oriented towards the recent regional tensional stress are the more useful for conducting the underground waters in the rock massif and, consequently, the most subject to chemical dissolution by the water.

The statistical approach for analysing of the conjugated shear joint systems use Nikolaev's method (NIKOLAEV, 1977). In this method the statistical joint pattern at every point of measurement is represented on rectangular density diagram with co-ordinate axes: direction of dip and dip angle. The joint density maxima of the conjugated pairs exhibit a clear asymmetry where the dissipation of the maxima is towards the minimum stress field axis. The reconstruction of the main stress axes orientations is easy enough, if the conjugated joint systems are correctly determined in the field. Thus, the direction of the opening of some systems of joints could be evaluated.

The meso-structural approach uses the concepts for the connection of the movement along shear joints (tectonic stria) and the existing stress. This approach is widely approved and mathematically cleared. The software FAULT (CAPUTO, 1989) allows the computing with Right Dihedron Method, P and T Axes Method and Conditioned Square Minima Method. The result is a reconstruction of the principal tectonic stress axes even, a few stria on slickensides are detected.

As a control could be used the fault-plane solution in the focus of the an earthquake, the nearest one, if possible. It will inform for the contemporary tectonic stress field.

The analyses of the shear joint systems in the limestones and the dolomites of the Triassic in the karst region of Bosnek were combined with the study of the excellent preserved strea on slickensides in the cave Duhlata (Fig.1), probably reflecting very young movements. With the data from the fault-plane solution of an earthquake of magnitude of about 4,0 near the Vitosha Mountain, it has been determined that two expressed tectonic stress fields were dominating for the formation of the contemporary fracturing of the sediments of the Triassic. The orientation of their principal tectonic stress axes explains well the formation of the fault structures of the region. The diagrams "a" on Fig.1 reflect the peculiarities of the determined as a post-Oligocene stress field.

The youngest tectonic stress field is plotted on the diagrams "b" on Fig.1 and, after the data from the earthquake, it is quite possible that exactly this tectonic stress field (Pliocene-Quaternary) could be nominated to be one of the very important factors for the karst formation. It imposes to accept the direction East-West as the main direction of draining of the underground waters.

3. Karst and karst waters

The principal role in the processes of karst formation in the region should be attributed to the Struma river and its tributaries, cutting into the carbonate massif. This process was interrupted by planations (GELLERT, 1932). The beginning of the formation of the contemporary relief and the karst should be accepted the time of the Lower Pliocene. Now, Struma river has expressed V-type valley with isolated remnants of 6 overwater terraces.

The superficial karst forms are not widely presented. Some karrens have been established in the Struma valley as well as a few dolines in the north-eastern part of the region, near the contact of the carbonate rocks with the effusive rocks of Senonian age. Till now, 26 caves have been discovered in the Bosnek karst region and, the biggest part of them is concentrated along the slopes of the river valley. In fact they are older and recent ways of the river waters. The most interesting cave is Duhlata with 17 000 m of labyrinths and its entrance being on the first overwater terrace. The underground stream in the cave passes 40 m bellow the river bed of Struma and has a few tributaries coming from the South. The above situated system of galleries is developed at 7 levels in the cave. The second cave with important length in the region is Vreloto, its underground stream fed up also by Struma river. This cave is an active resurgence of 6500 m of length, having also a number of levels inside.

The geological conditions predetermine the presence of two aquifers with their own independent karst system, above and below the local impermeable layer. Both have their beginnings from the river course and resurgence for the ends. They have been given by the name of their longest known caves (Table 1).

N	Name	Age of rocks	Area, km ²	Subsurface distance, km	Resur-gence	Q _{av} , dm ³ /s	Q _{max} , dm ³ /s	Q _{min} , dm ³ /s	Measurement
1	Vreloto	T ₂	35	4.5	Vreloto	310	1140	83	daily
2	Duhlata	T ₃	9	1.2	Duhlata	140 about	720	5	episodic

Table 1. Main karst systems in the region of Bosnek

Besides the feeding up from the waters of Struma river, the rainfall on the carbonate rocks are of importance also for the two karst systems. This influence is smaller for the karst system of Duhlata, because the abrupt slopes and the little surface of the outcrops. For the system of Vreloto, important quantities of superficial water come from North, where the non-karstic rocks are in its surface watershed. The river waters penetrate into the karst systems through the alluvium in the river bed. During the summer, the total quantity of river water is often lost along the section feeding the system of Vreloto and, in these cases, the superficial river is not existing along the section of the system of Duhlata. Parts of the underground water streams, in the both systems, can be found in some of the caves. For the system of Vreloto this is the little stream in the cave Chuchulian (40 m bellow the watercourse of Struma river), the underground river in the cave PPD, as well as the resurgence of Vreloto, itself. The relationship between the waters in these caves was established by tracers. The course time of the colour indicator is 2-3 days. The time delay of a few days was recorded for the discharges of the resurgence Vreloto after rainfall. The karst system of Duhlata has one principal underground river with southern tributaries, from the side of Struma river. This water goes out from the resurgence after 2 hours. The known discharge of the underground river is about 50 % of the discharge of the resurgence. In the cases of low waters this rate is bigger. It is evident that unknown waters joint the river after the last siphon of the cave. One part can be attributed to the stream in the cave "Academik", fed up also by Struma river. There are other resurgences, apart from the ones described, in the vicinity of the village of Bosnek (Fig.1). One of them is within the village, and it has relatively stable discharge. No dye was found in its water

during all the tests. North from the village, at about 2.5 km, one pulsing spring exists (Zhivata Voda) with a rate of discharge rarely reaching the level of 1 dm³/s. Popov Izvor drains the part of the Bosnek region, outside of the present study.

4. Hydrochemical characteristics and preliminary evaluation of the karst processes

The hydrochemical characteristics have been made on the base of sampling performed of waters from Struma river, from the resurgences and from the caves. Data from the permanent control station (included in the National Hydrogeological Networking) of the resurgence Vreloto, have been used, too. The waters have normally pH about 7. The lowest pH values are for the waters of Struma river before attending the carbonate rocks - from 6.4 to 7.0. The mineralization of the river waters changes from 90 to 145 mg/dm³ according to the seasons, and rises to 500-600 mg/dm³ for the waters in the fractures and the little streams in the cave Duhlata. The principal ions determining the chemical characteristics of the waters are these, taking part in the interrelation water ↔ carbonate rocks, namely HCO₃⁻, Ca²⁺, Mg²⁺. Their quantity is a function of the time of the underground course of the water. The performed evaluation for the proceeding of the karst process (BENDEREV & VESELINOV - in press) demonstrated that the waters of the both karst systems are unsaturated towards calcite and dolomite, i.e. they dissolve the rocks. During the dry season the waters of the resurgence of Duhlata have saturation index close to 1. Saturated are only the waters of some little streams of low velocity inside the cave Duhlata. The data obtained from the analyses of the waters allow to try one preliminary evaluation of the taken out quantity of substance from the both karst systems (Table 2). This Table is more correct than the one published by METODIEV (1983), because of the larger quantity of hydrochemical and hydrodynamic information. The level of reliability of the results is higher for the karst system of Vreloto then for Duhlata, due to the quantity of information.

N	Karst system	Area, km ²	Q _{av} , dm ³ /s	Samples	Δ Mineralization, mg/dm ³	Δ(CaCO ₃ + MgCO ₃), mg/dm ³	Karst denudation, t/year.km ²	Total denudation, t/year.km ²
1	Vreloto	35	310	10	170	96	47.5	26.8
2	Duhlata	9	140	4	190	94	93.2	46.1

Table 2. Denudation in region of Bosnek

5. Discussion and conclusion

The analysis of the geological and hydrogeological conditions of the karst region of Bosnek, based on the results of the performed studies, established the differences between the two separated karst systems. The main difference is the more variable regime of the discharge of the resurgence Duhlata and the speed movement of the water inside this karst system, due to the bigger volumes of the karst galleries. This situation is related to the fact, that the upper part of the system belongs to the older stage of the development of the karst system. The level of denudation is higher because the bigger quantities of water passing through the system. The modulus of the underground flow of Duhlata is two times higher than those for Vreloto.

The obtained results, resolving some of the problems of the karst systems of Bosnek region, lead to new interesting problems, related mainly to the genesis of the caves, to their age, as well as to the deeper understanding of the processes of karst formation and evolution in the time. The way to solve these problems is collect new hydrochemical and hydrodynamic data. Because its easy access and the possibility to follow the water ways in the caves, the presented region needs more efforts for understanding the peculiarities of the karst systems.

References

- BENDEREV, A. & S. VESELINOV. in press. Hydrochemical study in the karst region of Bosnek. *Bulg.caves*, 6 (in Bulg.).
- CAPUTO R. 1989. FAULT. A programme for structural analysis. Department of Earth Sciences, Univ. of Florence, 55 p.
- GELLERT, J. 1932. Beobachtungen und Betrachtungen zur Morphologie West-Bulgariens. *Z. Geomorph.* 2-3, 74-108.
- METODIEV, R. 1983. Hydrochemical and hydrogeological investigations in the region of Bosnek as evidence for presence of karst caverns, unconfirmed by other methods. Proc. ERCS - Sofia, Sept., 22-28, 1980, v. II, 514-5176 (in Bulgarian).
- NIKOLAEV, P. 1977. Method of statistical analysis of joints and reconstruction of the tectonic stress fields. - *J. of High Schools, Geology and Prospecting*, 12, p.103-115 (in Russian).
- SHOPOV, Y. et al. in press. High Resolution of Climatic Variations and Solar Forcing from the Luminescence or Speleothems from Duhlata cave, Bosnek, Bulgaria, Gold Water cave, Iowa, US and Rats Nest cave, Calgary, Canada. Contribution of Bulgarian workgroup IGCP 299 "Geology, Climate, Hydrology and Karst Formation".
- ZAGORCHEV, I. et al. 1994. Geological map of Bulgaria - scale 1:100000. Pernik. (in Bulgarian).

Application du concept de surface élémentaire représentative (S.E.R.) à l'étude comparée entre karstification et tectonique dans le département de la Vienne (France)

par Jacques Bodin & Moumtaz Razack

Laboratoire d'Hydrogéologie, URA CNRS 721 'HydrASA', Université de Poitiers
40, avenue du Recteur Pineau, 86022 Poitiers cedex, France

Abstract

Two hundred cave maps were analyzed statistically to identify the preferential directions of karstification in the department of Vienne (France). We show in this note how the stage of data input that precedes this kind of study can be optimized using the technique of automatic image analysis. Next, we use the concept of Representative Elementary Surface (BRACQ, 1994) to identify a number of preferential directions of karstification. Finally, the comparison between the identified karstic directions and the regional tectonic directions confirms the hypothesis of GUERIN (1973) and GRILLOT (1977) concerning the influence of tectonic factors on the karstification process.

Résumé

Une étude statistique des directions préférentielles de karstification dans le département de la Vienne (France) a été entreprise à partir de deux cents plans topographiques de réseaux karstiques. Nous montrons ici comment on peut optimiser la phase de saisie préalable à ce genre d'étude grâce à des techniques d'analyse automatique d'images. Ensuite, nous utilisons le concept de Surface Élémentaire Représentative (BRACQ, 1994) pour mettre en évidence certaines directions préférentielles de karstification. Enfin, la comparaison entre les directions karstiques mises en évidence et les directions tectoniques reconnues dans la région confirme les hypothèses émises par GUERIN (1973) et GRILLOT (1977) quant à l'influence du facteur tectonique dans les processus de karstification.

1. Introduction

En hydrogéologie des milieux fissurés et notamment en milieu karstique, l'un des problèmes fondamentaux est la détermination de la géométrie de l'aquifère. C'est en effet elle qui détermine principalement les modalités d'écoulement et conditionne l'emplacement des forages à réaliser en vue d'un captage.

On sait aujourd'hui que les circulations d'eaux souterraines dans les calcaires se font à la faveur des discontinuités de la roche (fractures et joints de stratification), dont l'évolution, par suite de phénomènes de dissolution et d'érosion, conduit à la karstification des roches.

Au début des années 1970, les travaux menés par GUERIN (1973) et GRILLOT (1977) ont montré qu'on pouvait mettre en évidence un lien étroit entre la répartition statistique des directions majeures de karstification et celle des directions de fractures liées à certaines phases tectoniques. Selon ces auteurs, les fractures les plus utilisées par le karst sont celles dont les directions ont permis de subir un allongement principal (X) perpendiculaire, que ce soit lors d'une phase de compression ou lors d'une phase de distension. Le karst utiliserait ensuite les fractures ayant eu un jeu ou un rejeu lors de la phase tectonique qui a précédé la karstification.

Durant les deux dernières décennies, peu de travaux ont été à nouveau consacrés à l'étude du facteur tectonique dans les processus de karstification. Le but de la présente note est donc de contrôler si les résultats obtenus par GRILLOT (1973) et GUERIN (1977) dans le Sud Est de la France se vérifient également dans le département de la Vienne. Nous introduirons dans cette étude un nouveau concept, celui de Surface Élémentaire Représentative (S.E.R.) développé par BRACQ (1994) pour les milieux crayeux, ainsi que de nouveaux outils numériques visant à compléter l'analyse géométrique quantitative des réseaux karstiques.

2. Présentation géographique et géologique du département de la Vienne

2.1. Cadre géographique

Situé entre le Massif Vendéen, au Nord Ouest (dépendance géologique du Massif Armoricaïn) et le massif Central au Sud Est, le département de la Vienne est un plateau d'altitude moyenne allant de 100 à 130 m, se relevant au contact du Massif Central et dont l'altitude décroît vers le Nord.

Cette région est constituée essentiellement de terrains sédimentaires jurassiques, crétacés et tertiaires, se continuant largement au Nord et au Sud en se rattachant au Bassin de Paris et au Bassin Aquitain.

D'un point de vue géologique, le département de la Vienne appartient donc d'une façon plus générale au Seuil du Poitou.

2.2. Les terrains en présence

Deux étapes majeures doivent être distinguées dans l'histoire structurale et sédimentaire du département de la Vienne :

- l'élaboration d'un socle primaire et précambrien, plissé et granité
- la constitution d'une couverture secondaire et tertiaire, faillée

Le Jurassique moyen et supérieur, caractérisé par des calcaires à faciès de plate-forme carbonatée, représente la plus grande part du substratum de la région. L'épaisseur de ces calcaires peut atteindre 200 m par endroits.

A l'échelle du Seuil du Poitou, les terrains se présentent sous la forme "d'un large anticlinal à grand rayon de courbure" sur lequel une partie seulement de la couverture a été conservée (GABILLY, 1978). Ce bombement s'est produit durant le dépôt des

assises du jurassique comme en témoigne leur amincissement à l'approche de l'axe du seuil.

2.3. Hydrogéologie

L'aquifère du Jurassique moyen constitue la principale réserve en eau souterraine du département de la Vienne. Cet aquifère, dont le mur est constitué par les marnes et les calcaires marneux du Toarcien, est en plus grande partie libre sur le territoire considéré. Il devient captif vers le Nord et le Sud Ouest sous les marnes de l'Oxfordien moyen. La circulation de l'eau dans les calcaires et les dolomies est liée à une fissuration importante (diaclasses ouvertes) et à une karstification développée qui assurent la continuité de la nappe.

La karstification n'intéresse que la partie supérieure du dépôt carbonaté, sa puissance excédant rarement 40 m. Sous la zone karstifiée, la porosité du magasin devient très faible et les transmissivités n'y sont plus que de 10^{-5} à 10^{-4} m²/s.

3. La fracturation de la couverture jurassique

3.1. Introduction

Les différentes données relatives à la fracturation de la couverture exposées dans la suite de cette note sont principalement issues des travaux de BURBAUD-VERGNEAUD (1987) qui, dans le cadre d'une thèse de troisième cycle, a étudié "la fracturation et les interactions socle-couverture dans le Seuil du Poitou".

3.2. La fracturation majeure

Les failles d'extension régionale sont globalement orientées NW-SE. Deux directions peuvent être distinguées sur la rosace directionnelle de fracturation, réalisée à partir du relevé synthétique des structures représentées sur les cartes géologiques de la région : N110-130 et N150.

3.3. La fracturation mineure : analyse géométrique des failles mesurées dans la couverture jurassique

La rosace de fréquence établie à partir d'environ 1100 mesures prises dans une trentaine de sites montre quatre pics dominants : N20-35, N110-135, N95, N175 (cf. fig. 1A). Par ailleurs, il est important de noter que des variations angulaires de l'ordre de 10° s'observent en fonction de la localisation du site.

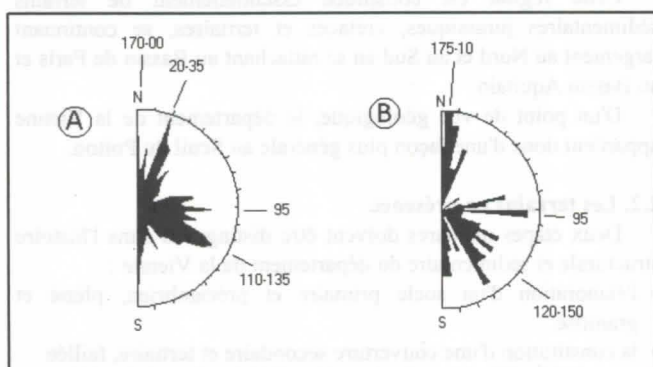

figure 1 : (A) : Répartition statistique des directions de failles mesurées dans la couverture jurassique ; (B) : Rosace de fréquence des fentes de tension (BURBAUD-VERGNEAUD, 1987).

3.3. Episodes tectoniques et chronologie relative

BURBAUD-VERGNEAUD (1987) a pu mettre en évidence cinq épisodes tectoniques responsables des déformations cassantes observées dans la couverture :

- à l'Eocène : compression N.NE-S.SW

- à l'Oligocène : distension NE-SW
- au début du Miocène : compression E.NE-W.SW
- à la fin ou post- Miocène : compression NW-SE
- au Pliocène supérieur : distension NW-SE

Une sixième phase encore plus récente, et responsable de fractures orientées N-S serait également à suspecter. Deux hypothèses de cinématique sont envisagées :

- une phase de distension avec une contrainte principale $\delta 1$ verticale et une contrainte minimale $\delta 3$ orientée EW.
- une phase de compression avec $\delta 1$ horizontale orientée NS et $\delta 3$ horizontale orientée EW.

4. Analyse statistique des directions préférentielles de karstification

4.1. Les documents de base

Les données servant de base à cette étude statistique sont des plans topographiques de réseaux karstiques suffisamment évolués pour être pénétrables. Ces plans topographiques ont été établis par les différents clubs de spéléologie du département de la Vienne (notamment le Spéléo-Club Poitevin).

Les documents réunis pour cette étude correspondent à la quasi-totalité des réseaux karstiques connus jusqu'à aujourd'hui et couvrent l'ensemble du département. La masse de documents étant considérable, seules les cavités ayant un développement supérieur à 10 m ont été retenues (cette limite pouvant être considérée comme la limite à partir de laquelle un réseau karstique a une signification), à l'exception de quelques petites cavités présentant un développement inférieur à 10 m mais avec des directions de karstification bien marquées.

L'ensemble des documents ainsi retenus correspond à 140 plans topographiques qui représentent un développement total cumulé de 12 km environ.

4.2. Traitement des données

4.2.1. Méthodologie

La méthode utilisée pour analyser les plans topographiques est analogue à celle décrite par GUERIN (1973) dans sa thèse de troisième cycle :

- chaque tronçon de galerie karstique est assimilé à un segment rectiligne, caractérisé par sa longueur, sa direction, et par sa position dans l'espace par rapport aux autres segments.
- dans le cas de salles ou de galeries de vastes dimensions, on définit des grands axes et des petits axes. Les premiers correspondent à l'allongement principal, de la salle ou de la galerie et les seconds représentent les directions secondaires.
- après avoir tracé sur une topographie tous les segments rectilignes correspondant aux axes de galeries karstiques, on numérise ces segments à l'aide d'une table à digitaliser. Chaque segment est ainsi défini par les deux points correspondant à ses extrémités. Cette numérisation vectorielle est effectuée par l'intermédiaire du programme LINEAM (DELAY *et al.*, 1993 ; BODIN, 1996).

4.2.2. Une alternative à la saisie par table à digitaliser : l'analyse automatique d'images

Lorsque le nombre de documents à traiter est important, l'opération de saisie précédemment décrite est souvent longue et fastidieuse. Nous allons présenter dans ce chapitre une alternative permettant d'automatiser cette opération à l'aide d'une nouvelle technique faisant appel à des opérateurs de morphologie mathématique. Cette technique a été développée sous forme d'un programme (ANIM) au sein du logiciel LINEAM (BODIN, 1996).

Le principe consiste à traiter des images numériques de topographies karstiques, préalablement saisies à l'aide d'un scanner, et légèrement modifiées de façon à ce que tous les réseaux karstiques soient représentés en noir sur les images. Le traitement s'effectue au niveau des pixels en comparant les configurations de pixels de l'image initiale avec des matrices de trois pixels sur trois pixels dont on connaît parfaitement la configuration au niveau des pixels allumés ou éteints. Ce type de matrice est appelé *élément structurant*.

Nous allons chercher à définir automatiquement le *squelette* (ou "l'ossature") des réseaux karstiques par l'intermédiaire de transformations agissant sur les pixels de l'image numérique. Ces transformations reviennent à supprimer (ou éteindre) les pixels répondant aux configurations de voisinages suivantes :

$$\begin{matrix} 0 & 0 & 0 \\ \# & 1 & \# \\ 1 & 1 & 1 \end{matrix} \quad \text{et} \quad \begin{matrix} \# & 0 & 0 \\ 1 & 1 & 0 \\ \# & 1 & \# \end{matrix} \quad \text{et toutes les rotations} \\ \text{à } \pi/2 \text{ possibles.}$$

Une fois le squelette établi (cf. fig. 2), le programme ANIM va effectuer les opérations suivantes :

1. suppression des points d'intersection entre plusieurs linéaments
2. séparation des lignes brisées en deux tronçons distincts
3. suppression des pixels isolés
4. première reconnaissance des extrémités de chaque linéament
5. réajustement des linéaments situés dans un même alignement et proches les uns des autres.
6. sauvegarde des coordonnées Lambert des extrémités de chaque linéament dans un fichier .

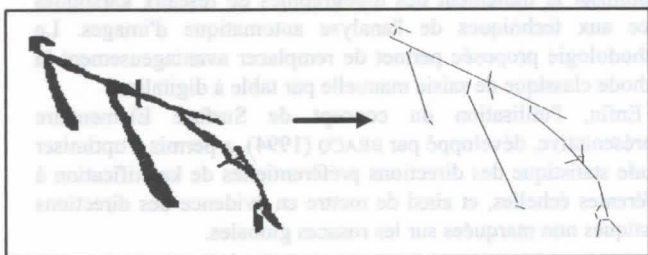

figure 2 : Saisie des directions préférentielles de karstification par analyse automatique d'images sur des topographies de réseaux karstiques (programme ANIM, BODIN 1996)

Intérêts et limites de la méthode

Outre un gain de temps relativement appréciable, ce mode de saisie permet d'atteindre un résultat identique dans la saisie d'un même document par les différents utilisateurs.

Le principal inconvénient est lié à la taille maximale des images numériques pouvant être analysées par le programme ANIM. Cette limite, de 1216*960 pixels, oblige à découper les documents initiaux de taille importante en plusieurs éléments qui devront être saisis les uns après les autres.

4.3. Résultats

4.3.1. Répartition statistique des directions préférentielles de karstification à l'échelle du département

Les rosaces de fréquences calculées en nombre et en longueurs cumulées de linéaments par classes d'orientations de 10° montrent une forte dispersion des directions de galeries karstiques : aucune classe directionnelle ne dépasse le seuil de 10% en importance relative.

Quelques directions semblent cependant légèrement privilégiées par le karst : N0-10, N110-120 et N130-140 (cf. fig. 3).

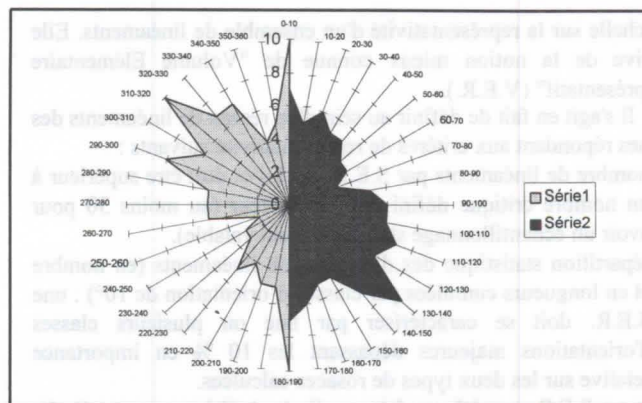

figure 3 : Répartition statistique des directions préférentielles de karstification à l'échelle du département de la Vienne (Série 1 : pourcentages en longueurs cumulées de linéaments ; Série 2 : pourcentages en nombre de linéaments).

4.3.2. Répartition géographique

La zone couverte par l'ensemble des topographies étudiées a été divisée en 66 mailles carrées de 10 km de côté, et on a recalculé la répartition statistique des directions préférentielles de karstification à l'intérieur de chaque maille.

Le résultat de cette étude, visible sur la figure 4, montre là encore une forte dispersion, cette fois-ci géographique, des directions préférentielles de karstification.

On peut trouver dans chaque maille une ou plusieurs des directions citées au paragraphe précédent, mais aussi de nouvelles directions (notamment la direction E-W) qui n'apparaissent pas sur les rosaces globales.

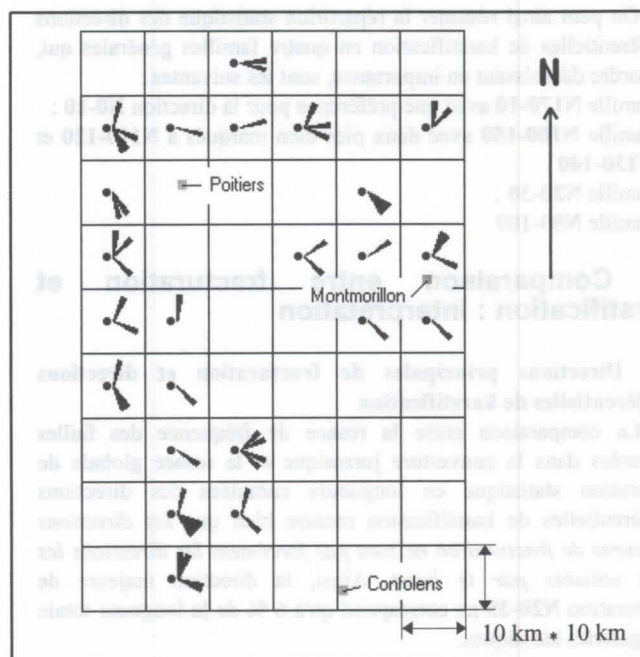

figure 4 : Répartition spatiale des directions préférentielles de karstification à l'échelle du département de la Vienne (programme DENS, DELAY et al., 1993).

4.3.3. Notion de Surface Élémentaire Représentative

Une telle dispersion des résultats, tant sur le point statistique que géographique, est difficilement exploitable. Nous avons donc cherché à optimiser l'étude des directions préférentielles de karstification à l'aide d'un nouveau concept : celui de "Surface Élémentaire Représentative".

La notion de Surface Élémentaire Représentative (S.E.R.) a récemment été développée par BRACQ (1994) pour étudier l'effet

d'échelle sur la représentativité d'un ensemble de linéaments. Elle dérive de la notion mieux connue de "Volume Élémentaire Représentatif" (V.E.R.).

Il s'agit en fait de définir au sein d'un réseau de linéaments des zones répondant aux critères de représentativité suivants :

1. nombre de linéaments par S.E.R. : celui-ci doit être supérieur à un nombre critique défini par l'utilisateur (au moins 30 pour avoir un échantillonnage statistiquement valable).
2. répartition statistique des directions de linéaments (en nombre et en longueurs cumulées par classes d'orientation de 10°) : une S.E.R. doit se caractériser par une ou plusieurs classes d'orientations majeures dépassant les 10 % en importance relative sur les deux types de rosaces calculées.

Chaque S.E.R. possède en fait une limite inférieure et une limite supérieure entre lesquelles les deux conditions précédentes sont satisfaites. Ce sont ces limites, assimilées à des mailles carrées, que nous avons recherché à l'aide du programme ARES (BODIN, 1996) sur les topographies karstiques numérisées.

4.3.4. Résultats de la recherche de Surfaces Élémentaires Représentatives sur le réseau karstique de la Vienne

Vingt-deux Surfaces Élémentaires Représentatives ont pu être mises en évidence. Leurs tailles varient de 200 m à 11 km pour les limites inférieures et de 3 km à 15 km pour les limites supérieures.

Chacune de ces SER est caractérisée par une ou deux directions principales de karstification dépassant les 10 % en importance relative sur les rosaces calculées. Si la majorité de ces directions appartiennent bien à une des trois familles légèrement dominantes sur les rosaces globales (cf § 4.3.1.), certaines SER montrent également de nouvelles directions, de portée locale : N20-30, N80-90, ...

On peut ainsi résumer la répartition statistique des directions préférentielles de karstification en quatre familles générales qui, par ordre décroissant en importance, sont les suivantes :

- famille N170-10 avec une préférence pour la direction N0-10 ;
- famille N100-150 avec deux pics bien marqués à N110-120 et N130-140 ;
- famille N20-30 ;
- famille N80-100.

5. Comparaison entre fracturation et karstification : interprétation

5.1. Directions principales de fracturation et directions préférentielles de karstification

La comparaison entre la rosace de fréquence des failles mesurées dans la couverture jurassique et la rosace globale de répartition statistique en longueurs cumulées des directions préférentielles de karstification montre bien que *les directions majeures de fracturation ne sont pas forcément les directions les plus utilisées par le karst*. Ainsi, la direction majeure de fracturation N20-35 ne correspond qu'à 6 % de la longueur totale des galeries karstiques.

5.2. Directions d'allongement et directions préférentielles de karstification

La comparaison entre la rosace fréquentielle des fentes de tension (cf. fig. 1B) et la répartition des directions préférentielles de karstification est très intéressante. En effet, on peut voir clairement que les directions utilisées par le karst correspondent toutes à des directions de plans axiaux de fentes de tension. Autrement dit, les failles utilisées préférentiellement par le karst correspondent toutes à des failles ayant subi dans leur histoire

tectonique un allongement principal (X) de direction perpendiculaire à la direction de leur plan de faille :

- famille N170-10 :
 - ⇒ "phase récente" (en compression ou en distension) avec (X) orienté E-W
 - ⇒ compression N.NE-S.SW avec (X) E.SE-W.NW
- famille N100-150 :
 - ⇒ compression NW-SE avec (X) NE-SW
 - ⇒ distension NE-SW avec (X) NE-SW
- famille N20-30 :
 - ⇒ distension NW-SE avec (X) NW-SE
 - ⇒ compression N.NE-S.SW avec (X) E.SE-W.NW
- famille N80-100 :
 - ⇒ compression E-W avec (X) N-S

6. Conclusion

Les résultats de cette étude s'accordent avec ceux obtenus par GUERIN (1973) et GRILLOT (1977) et confirment donc les hypothèses émises par ces auteurs quant à l'influence du facteur tectonique dans les processus de karstification : les failles utilisées préférentiellement par le karst correspondent toutes à des failles ayant subi dans leur histoire tectonique un allongement principal (X) de direction perpendiculaire à la direction de leur plan de faille. Dans le cas du département de la Vienne, il est d'ailleurs intéressant de noter que les trois familles principales d'axes karstiques regroupent des failles ayant subi dans leur histoire deux jeux tectoniques de cette nature, dont un parmi les trois phases tectoniques les plus récentes.

Nous avons également montré comment il était possible d'optimiser le traitement des topographies de réseaux karstiques grâce aux techniques de l'analyse automatique d'images. La méthodologie proposée permet de remplacer avantageusement la méthode classique de saisie manuelle par table à digitaliser.

Enfin, l'utilisation du concept de Surface Élémentaire Représentative, développé par BRACQ (1994), a permis d'optimiser l'étude statistique des directions préférentielles de karstification à différentes échelles, et ainsi de mettre en évidence des directions karstiques non marquées sur les rosaces globales.

Références

- ♦ BODIN J. - (1996) - Contribution à la modélisation géométrique des réservoirs fissurés : analyse automatique d'images, recherche de Surfaces Élémentaires Représentatives et analyse fractale - Mémoire de DEA HHGG, Université de Poitiers, 42 p.
- ♦ BRACQ P. - (1994) - L'effet d'échelle sur le comportement hydrodynamique et hydrodispersif de l'aquifère crayeux, apports de l'analyse morphostructurale - Publ. Soc. Géol. du Nord, 244 p.
- ♦ BURBAUD-VERGNEAUD M. - (1987) - Fracturation et interactions socle-couverture : Le Seuil du Poitou - Thèse de 3ème cycle, Université de Poitiers, 203 p.
- ♦ DELAY F., BRACQ P. - (1993) - A vectorial method for the study of the spatial distribution of morphological features applied to the needs of hydrogeology - Computers and Geosciences, Volume 19, n° 7, pp. 965-980.
- ♦ GABILLY J. - (1978) - Guides géologiques régionaux : Poitou, Vendée, Charentes - Ed. Masson, Paris, 200 p.
- ♦ GRILLOT J.C. - (1979) - Structure des systèmes aquifères en milieu fissuré. Contribution méthodologique à cette connaissance - Thèse de Doctorat d'Etat, Université de Montpellier, 212 p.
- ♦ GUERIN R. - (1973) - Un exemple du rôle de la tectonique et de la microtectonique dans la géométrie des écoulements karstiques fossiles et actuels : Le Bas-Vivarais calcaire - Thèse de 3ème cycle, Univ. Sc. et Tech. du Languedoc, Montpellier, 105 p.

Etude géophysique et piézométrique d'un karst côtier à Zanzibar

par Bernard Collignon
HYDRO CONSEIL, 11, rue Simonet, 75013 Paris

Résumé

Un vaste karst (400 km²), sans le moindre cours d'eau, constitue la partie méridionale de l'île principale de Zanzibar. La prospection géophysique (par sondages électriques) est extrêmement difficile, faute d'un sol conducteur, mais elle démontre clairement que l'ensemble du karst profond est envahi par l'eau de mer. La lentille d'eau douce ne fait que quelques dizaines de mètres d'épaisseur, et l'exploitation des forages doit être conduite avec prudence, pour éviter de pomper de l'eau salée. Ces résultats sont confirmés par l'étude des variations piézométriques dans l'espace et dans le temps, à l'échelle quotidienne (influence des marées) et saisonnière (influence des précipitations). Les calcaires récifaux se comportent comme un aquifère homogène, très perméable. L'existence de drains karstiques très développés n'est pas prouvée.

Mots-clés

Zanzibar - karst - eau salée - géophysique - piézométrie - perméabilité - marée

Abstract

A vast karst (400 km²), without any running water, constitutes the southern part of the main island of Zanzibar. The geophysical prospecting (by electrical sounding) is very difficult, because there is no conductive soil, but it demonstrates clearly that the whole deep karst is invaded by the sea water. The sweet water layer is only some ten meters thick, and the wells exploitation has to be driven carefully, in order to avoid to pump sea water. These results are confirmed by the study of piezometric variations study in space and in time, at the daily scale (tide effect) and seasonal scale (influence of precipitations). Reef limestones behave as an homogeneous aquifer, very permeable. It is not proven that karstic channels are very developed.

Key words

Zanzibar-karst-salty water - geophysics - piezometry - permeability - tide

1. Éléments de géologie

Zanzibar est un petit pays de 2 500 km², constitué de deux îles (Unguja et Pemba), situées à 50 km de la côte orientale d'Afrique, au large de la Tanzanie, avec laquelle Zanzibar est fédérée. Nous nous intéressons ici à l'île méridionale, Unguja, constituée à 70 % de calcaires, et dont la péninsule méridionale, d'une superficie de 400 km² est entièrement recouverte de calcaires.

Ces calcaires correspondent à des récifs coralliens, dont l'âge s'étend du Miocène à la période actuelle. Il s'agit de calcaires vacuolaires, dont la porosité, telle qu'elle apparaît à l'affleurement, dépasse fréquemment 10 % et dont la perméabilité intrinsèque (hors toute karstification) est probablement forte.

Les deux îles correspondent à des horsts (STOCKLEY, 1928). Elles sont séparées du continent par de profonds fossés (dont la profondeur atteint 600 mètres entre Pemba et le continent). Elles sont constituées uniquement de roches sédimentaires. Les forages pétroliers montrent que l'épaisseur des sédiments dépasse 2500 mètres, ce qui implique une subsidence assez rapide durant la seconde moitié du Cénozoïque.

2. Le karst du sud de Unguja

Le relief de la partie méridionale de Unguja est très faible : la grande majorité de cette péninsule de 400 km² se situe à moins de 20 mètres d'altitude et elle culmine à 40 mètres.

Les pluies sont abondantes : 1400 à 1600 mm/an, concentrées en une grosse saison des pluies, de mars à mai - Masika - et une petite saison des pluies, d'octobre à décembre - Vuli. Malgré cette forte pluviométrie (il tombe 600 millions de m³/an sur la péninsule), il n'existe aucun cours d'eau superficiel. Le paysage se réduit à un terrain rocailleux, où les lapiès sont assez bien développés, mais pas très impressionnants (petits pinacles, lapiès de paroi,...). Cependant, ce karst n'est pas très spectaculaire, à cause du fort développement d'une végétation broussailleuse qui recouvre la plus grande partie des calcaires, et dont on se demande comment elle se développe, car il n'y a pratiquement pas de sol. Les habitants de cette péninsule pratiquent une agriculture sur brûlis peu performante (maïs, courges, manioc, patates douces).

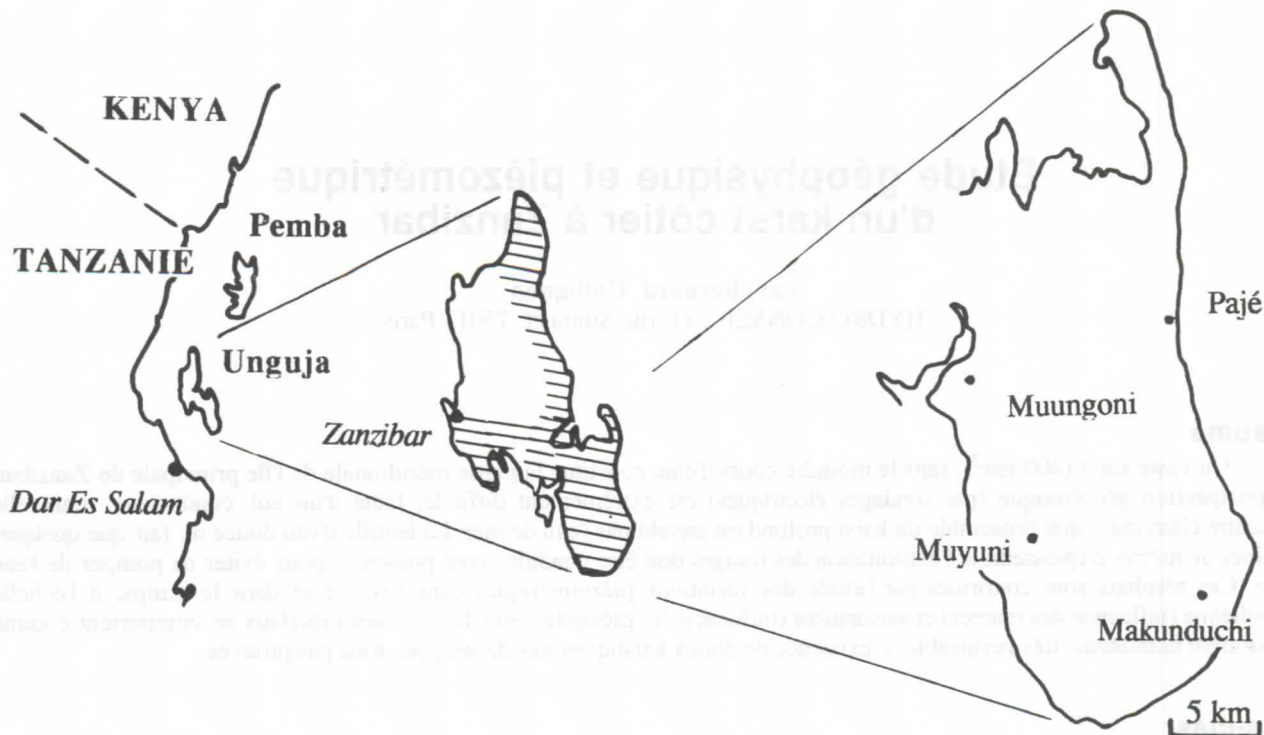

Figure 1. Localisation de l'île de Unguja (50 km au large de la Tanzanie). Extension des affleurements de calcaires récifaux. La péninsule méridionale où a été conduite l'étude.

3. Les difficultés de l'approvisionnement en eau

Il n'existe aucune rivière, même temporaire, dans la partie méridionale de l'île de Unguja et les ressources en eau superficielles sont considérées comme nulles (HALCROW, 1994). Les points d'eau les plus nombreux sont des puits traditionnels creusés dans les petites crêtes sableuses (d'origine éolienne ?) qui s'étendent sur une dizaine de km² à proximité de Muyuni et Makunduchi, près de la côte. Ces puits donnent des débits assez faibles et une eau parfois assez saumâtre (conductivité de 600 à 1500 micro-Siemens par cm).

Mais il existe aussi des points d'eau naturels d'excellente qualité dans les calcaires. Nous en avons visité une dizaine. Il s'agit de petits avens de quelques mètres de profondeur, exploités par puisage à la main ainsi que par 5 grosses stations de pompage motorisées dont le prélèvement global dans l'aquifère atteint 5 000 m³/jour. La conductivité est généralement inférieure à 700 µS/cm. Cependant, certains puits côtiers creusés dans les calcaires sont salés et l'exploitation doit donc être conduite avec prudence.

Un programme de forage vient d'être lancé par le Water Department, pour couvrir les besoins en eau potable d'une quinzaine de milliers de personnes, dispersées en une vingtaine de villages. Ce programme est financé par le Fonds d'Abu Dhabi et sa maîtrise d'oeuvre a été confiée à Louis Berger International, qui a sous-traité les études géologiques et géophysiques à HYDRO CONSEIL.

Figure 2. Pluviométrie mensuelle moyenne sur l'île de Unguja (en mm/mois).

4. Comment trouver de nouvelles ressources en eau

On cherche d'abord des affleurements calcaires, car ce sont les formations les plus perméables (quelques essais antérieurs de forage dans les sables ont donné des débits inférieurs à 5 m³/h). La prospection géologique classique est facile.

On cherche ensuite des zones perméables. Il n'y a pas trop d'inquiétude à se faire, tous les forages implantés dans ces calcaires ont donné jusqu'à présent de forts débits (plus de 20 m³/h) et dans le bilan en eau de l'île, on a utilisé pour cette zone des valeurs de la transmissivité comprises entre 0,06 et 0,08 m²/s, ce qui est assez considérable (HALCROW, 1994). Au cas où un débit beaucoup plus fort serait recherché, il sera toujours possible d'implanter les forages sur les grands linéaments Nord-Sud, bien visibles sur les photos aériennes. Nous y avons implanté deux des forages prévus.

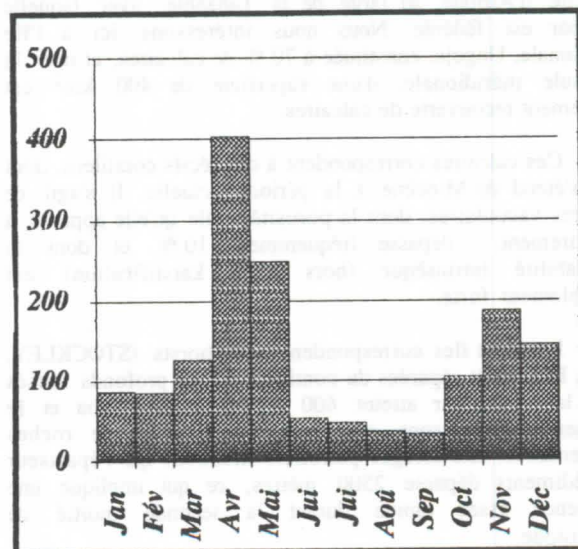

Le véritable problème n'est pas de trouver de l'eau en abondance, c'est de trouver de l'eau douce. En effet, de nombreux puits contiennent de l'eau salée ou saumâtre et on peut donc raisonnablement craindre qu'il y ait de l'eau salée en profondeur. Est-il possible d'estimer l'épaisseur de la couche d'eau douce exploitable, afin de déterminer le programme de forage ?

5. La prospection géophysique démontre la présence d'eau salée en profondeur

Notre prospection géophysique avait deux objectifs :

- déterminer s'il y avait de l'eau salée en profondeur ;
- évaluer l'épaisseur de la couche d'eau douce exploitable.

La prospection par sondages électriques en courant continu est bien adaptée à ce type de cas, où il s'agit de délimiter l'interface eau douce / eau salée (pas de contraste de densité, fort contraste de résistivité, marqueur horizontal). Nous avons utilisé le dispositif classique de Schlumberger, avec des longueurs de ligne allant de 100 à 400 mètres.

Nous avons cependant rencontré de grosses difficultés expérimentales, et une équipe danoise travaillant dans la même région a rencontré les mêmes problèmes : comme il n'y a pas de sol, la résistivité des couches superficielles est énorme (jusqu'à 10 000 ohm-mètres), ce qui rend très difficile l'injection du courant, même en arrosant abondamment les électrodes d'eau salée.

Les résultats sont cependant intéressants et répondent bien aux questions posées :

- toutes les courbes expérimentales, sans exception, plongent sur près de 4 intervalles logarithmiques, depuis la résistivité énorme des calcaires secs (10 000 ohm-mètres), jusqu'aux calcaires saturés d'eau salée (2 ohm-mètres) ;
- sur quelques sondages, on peut observer un faible palier de résistivité intermédiaire, qui correspond probablement au calcaire saturé d'eau douce

Pour améliorer l'interprétation des résultats, nous avons utilisé une modélisation mathématique. On peut effectivement caler sur les points expérimentaux un modèle qui inclut une couche d'eau douce, mais l'épaisseur de cette couche est très difficile à déterminer (c'est le phénomène bien connu des géophysiciens de la "disparition" apparente d'une couche de résistivité intermédiaire comprise entre un terrain très résistant et un terrain très conducteur).

6. La surface piézométrique est proche du niveau de la mer

Les études piézométriques confirment que la couche d'eau douce n'est pas très épaisse. En effet, en tout point de la presqu'île, l'altitude de la surface piézométrique ne dépasse pas 1,5 mètres au-dessus du niveau de la mer : avec le modèle classique d'équilibre hydrostatique (lentille de Ghijben-Herzberg), l'épaisseur de la couche d'eau douce et légèrement saumâtre vaudrait donc au maximum 60 mètres (selon le modèle bien connu d'équilibre hydrostatique de la lentille d'eau douce sur l'eau de mer, l'épaisseur de la couche d'eau douce vaut 40 fois l'altitude de la surface piézométrique).

Figure 3. Les courbes de sondage électrique à Uguja plongent rapidement vers de très basses valeurs de résistivité.

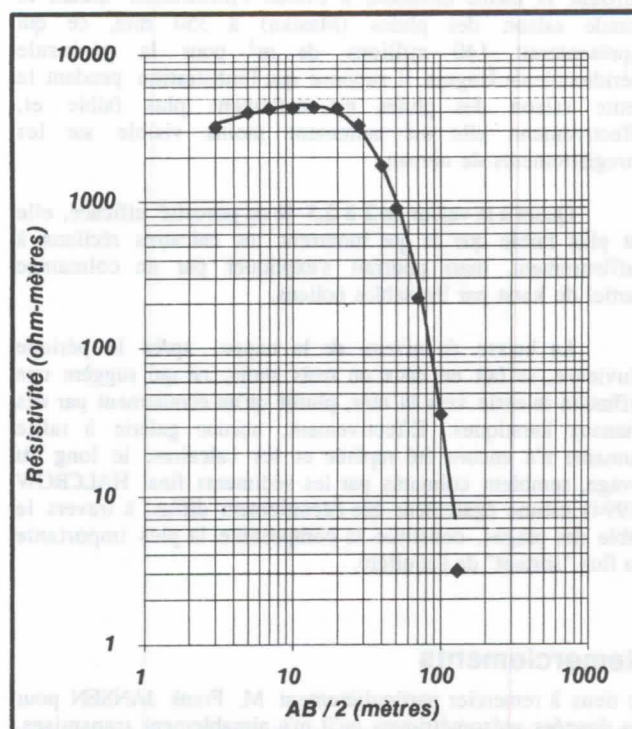

7. L'influence de la marée est très peu sensible

Dans des calcaires récifaux aussi perméables, nous pensons que l'effet des marées serait sensible, loin à l'intérieur des terres, et qu'il constituerait l'un des facteurs déterminants de la contamination des aquifères par l'eau de mer. Nous avons donc essayé d'observer l'effet des marées sur le niveau de l'eau dans les puits. En pratique, cet effet n'est pratiquement pas sensible dans les points d'eau situés de 0,6 à 3 km du rivage (les variations, de moins de 2 cm, sont à la limite de la précision du dispositif de mesure). Un seul puits montre des oscillations sensibles, d'une amplitude inférieure à 10 cm, et il est situé à seulement 100 mètres de la mer.

8. Une recharge estivale sensible

Les variations saisonnières de la surface piézométrique sont très nettes et synchrones sur l'ensemble des puits (voir figure 4). A la suite des pluies du printemps 1996 (500 mm), la remontée atteint 50 à 70 cm selon les puits. Une telle amplitude correspondrait à une couche d'eau douce supplémentaire de 20 à 28 mètres.

Une telle remontée du niveau équivaldrait (par exemple) à l'infiltration de 400 mm dans un terrain ayant 2 à 2,5 % de porosité efficace. Ces valeurs, tant de la lame d'eau infiltrée que de la porosité efficace, sont en accord avec ce que l'on a observé ailleurs dans ce type d'aquifère. HALCROW (1994), en utilisant la même méthode, a évalué l'infiltration durant la grande saison des pluies (Masika) à 350 mm, ce qui représenterait 140 millions de m³ pour la péninsule méridionale de Unguja. Il suppose que l'infiltration pendant la petite saison des pluies est nettement plus faible et, effectivement, elle est nettement moins visible sur les enregistrements de niveau.

Quant à la valeur de 2 à 2,5 % de porosité efficace, elle est plus faible que ce que montrent les calcaires récifaux à l'affleurement, mais pourrait s'expliquer par un colmatage partiel du karst par les sables éoliens.

La baisse du niveau de la nappe, après la période pluvieuse, se fait en deux ou trois mois, ce qui suggère une diffusion ralentie vers la mer, plutôt qu'un écoulement par des chenaux karstiques. Effectivement, aucune galerie à taille humaine n'a encore été repérée et les calcaires, le long du rivage, semblent colmatés par les sédiments fins. HALCROW (1994) estime également que l'écoulement diffus, à travers le sable des plages, constitue la composante la plus importante du flux "sortant" de l'aquifère.

Remerciements

Je tiens à remercier particulièrement M. Frank JANSEN pour les données piézométriques qu'il m'a aimablement transmises, ainsi que MM. Bruno Valfrey et Patrick Mullen, qui ont participé aux campagnes de mesure géophysique et topographique.

9. Conclusions

La prospection géophysique dans la péninsule méridionale de Unguja indique que l'eau salée y est omniprésente à partir d'une profondeur qui n'excède guère 50 mètres. Il existe cependant partout une couche d'eau douce superficielle permanente, exploitable par puits et forages. La prospection électrique ne permet pas de mesurer l'épaisseur de cette couche. Cette réserve d'eau douce est sérieusement contaminée par l'eau de mer durant la saison sèche mais elle se recharge chaque année suite aux fortes précipitations estivales.

La forte perméabilité des calcaires n'est peut-être pas due à la karstification, mais à la structure vacuolaire originelle des calcaires récifaux. Leur porosité efficace atteindrait 2 à 2,5 %, selon les variations piézométriques enregistrées à la suite des pluies.

Des forages de débit moyen (5 à 20 m³/heure) peuvent être implantés un peu partout, pour assurer l'approvisionnement en eau des villages. On cherche simplement à minimiser les risques de contaminations par l'eau de mer en les implantant le plus loin possible de la côte. Des forages de plus gros débit méritent une implantation plus soignée, en utilisant les photos aériennes.

Références

- STOCKLEY, G.M. 1928. Report on the Geology of the Zanzibar Protectorate. Ed. Gov. Zanzibar.
- JOHNSON (United Nations). 1987. Hydrogeological map of Zanzibar. UNDTCD Project URT / 80 / 001.
- HALCROW (1994). The development of Water Resources in Zanzibar. Ed. Gov. Zanzibar.

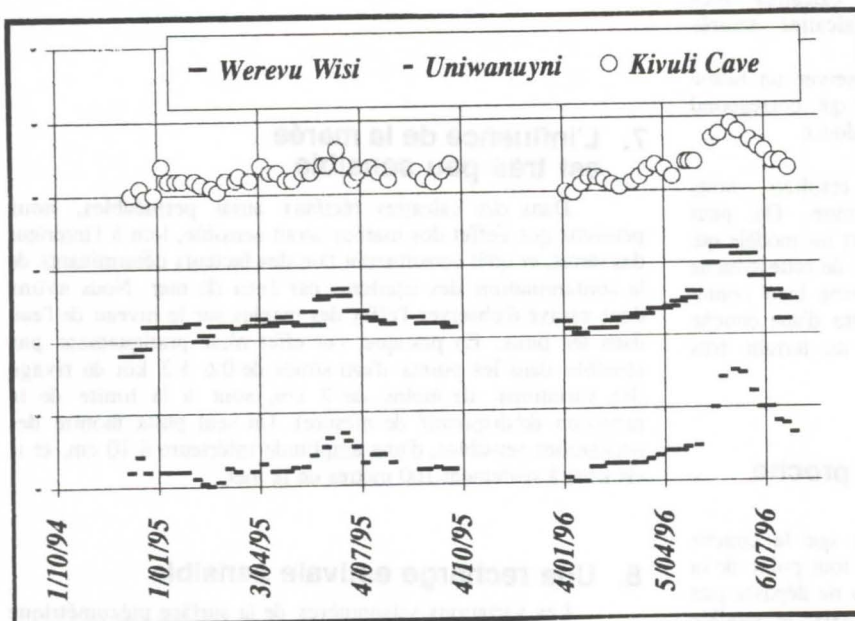

Figure 4. Variations du niveau piézométrique synchrones et suivant de peu la saison des pluies dans trois puits de la zone d'étude - échelle verticale: 0,5 mètre entre chaque ligne (ces données nous ont été aimablement transmises par M. Frank JANSEN, qui prépare une thèse sur l'intrusion saline à Zanzibar).

Transition between Hydrothermal and Cold-Water Karst

Yuri V. Dublyansky

Institute of Mineralogy and Petrography, Russian Academy of Sciences, Siberian Branch, 3 University Avenue, 630090, Novosibirsk, RUSSIA

Abstract

Hydrothermal karst grades into "cold" karst in time (decay of hydrothermal systems) as well as in space (from depth toward the Earth's surface). Examples of karst, developed in an environment transitive between hydrothermal and "cold water" were studied in Hungary, USA, and Kirghizstan. "Transitional" karst develops in both phreatic and vadose zones. The leading speleogenetic processes are: - CO₂- and H₂S-related corrosion, - mixing/cooling corrosion, - condensation corrosion, - replacement corrosion. Processes, controlling speleothem growth are: - CO₂-degassing, - evaporation, - replacement (calcite-gypsum), and - aerosol mass-transfer.

Features of fossil transitional karst, which can help in discriminating the latter from both hydrothermal and "cold" karsts are: - cave morphology, - mineralogy of cave deposits; - morphology, isotopic properties ($\delta^{13}\text{C}$ and $\delta^{18}\text{O}$), and content of trace elements (Mn, Fe, Pb, and Sr) in speleothems; - temperature and salinity of paleowaters (by fluid inclusions).

1. Introduction

During the last two decades, our knowledge about the hydrothermal karst has significantly advanced. Hydrothermal origin was established for many large cave systems of the World: e.g., caves of South Dakota, Wyoming, North Algeria, South Kirghizstan, Hungary, Crimea, Caucasus, Southeast Iran, Poland, England, Israel, and many other places. Hydrothermal caves and cave deposits exhibit striking dissimilarities to those of the common "cold" karstic origin. Criteria for distinguishing hydrothermal vs. cold karst were suggested by V. DUBLYANSKY (1980), COLLIGNON (1983), BAKALOWICZ *et al.* (1987), Y. DUBLYANSKY (1989), and FORD & WILLIAMS (1989).

At the same time, more becomes known about different regimes within hydrothermal karst itself. It has recently become apparent that transition between high-temperature hypogene regime and low-temperature epigene one is accompanied by a very specific type of kartsification. This **transitional karst** is the theme of the present article. Very generally, transitional karst might be defined as *karst occurring near the Earth's surface at temperatures just slightly elevated relative to those of "normal" meteoric waters* in the region.

Hydrothermal karst grades into the cold karst in time along with the decay of hydrothermal systems. At these stages both temperatures and discharges in the systems decrease, and eventually they cease to function. Spatially, temperatures of rising thermal waters decrease along their path from depth towards the Earth's surface.

2. Chemistry of fluids and processes of cave excavation

Significant dissolution of carbonate rocks requires acidic waters. Hydrothermal, and more generally, hypogene caves are formed by acids of deep-seated origin, or epigenic acids rejuvenated by deep-seated process (PALMER, 1991). The major hypogene acids are carbonic acid, originated from igneous activity and metamorphism of buried carbonates, as well as hydrosulfuric acid (aqueous H₂S) originated from redox reactions. Hydrothermal caves associated with CO₂ and caves formed by waters containing H₂S are thought to represent two major classes of hypogene caves (FORD & WILLIAMS, 1989).

Dissolution by rising thermal water (CO₂)

Thermal waters, rising from significant depth are often saturated with CO₂. The latter may originate from metamorphism of carbonate rocks or from magmatic and volcanic activity. Solu-

bility of CO₂ in water depends on both temperature and pressure. Typical behavior of CO₂ saturation concentration in hydrothermal environment was calculated by MALININ (1979) and is shown in figure 1. The figure implies that water saturated with respect to CO₂ at depth, become supersaturated as it rises towards the surface. Hence, CO₂ must exsolve in the gaseous phase and leave the system. However, rising carbonic thermal waters cool down and, due to inverse relationship between carbonate solubility and temperature, they may acquire and maintain solution aggressiveness - even at decreasing CO₂ levels. Figure 1 shows that solubility of CaCO₃ increases along the fluid path, and only near the land surface it drops drastically. Such a non-linear behavior lead to the appearance of two geochemical zones: zone of carbonate dissolution, and zone of carbonate precipitation.

Dissolution due to oxidation of sulfides (H₂S)

Caves, formed in association with H₂S bearing waters are classed as hypogene, though they are not necessarily thermal. Examples of active caves developing due to oxidation of hydrogen sulfide are known in the USA (Wyoming, caves of the Big Horn Basin; EGEMEIER, 1981). On the basis of the analysis of spring chemistry data, WORTHINGTON & FORD (1995) argued that elevated contents of sulfate is an inherent feature of thermal springs in carbonate terrane.

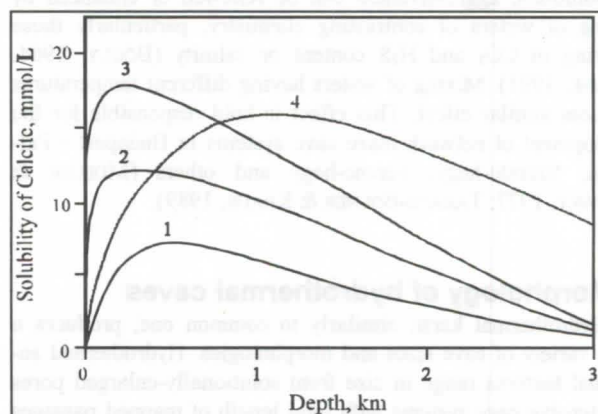

Figure 1 : Solubility of calcite in ascending CO₂ bearing thermal waters (by MALININ, 1979). Temperature decreases from depth towards surface: 1 - 225-100; 2 - 225-50; and 3 - 225-25 °C (pure water). 4 - 225-100 °C for NaCl solution with ionic strength I = 1

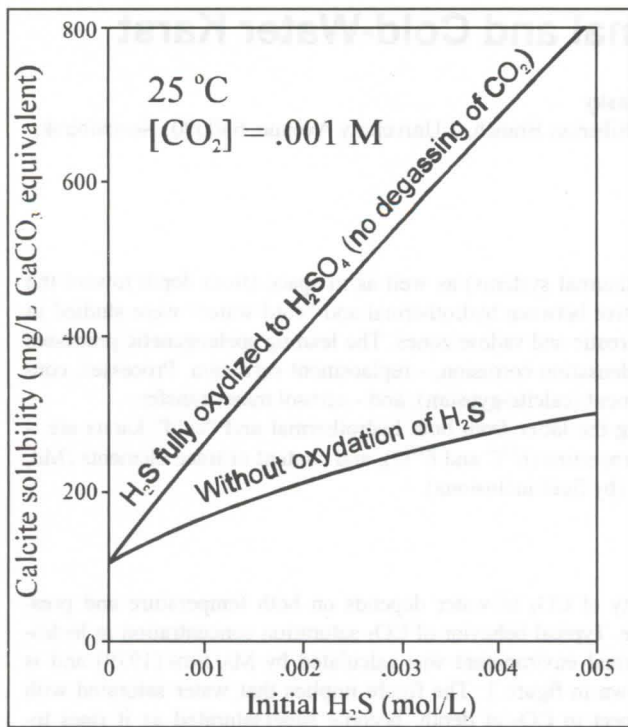

Figure 2 : Solubility of calcite in an $H_2O-H_2SO_4$ system (by PALMER, 1991)

Sulfuric waters become aggressive when their dissolved H_2S oxidizes in oxygen-rich waters or on the contact with the air to form sulfuric acid. Figure 2 (reproduced from PALMER, 1991) shows that conversion of H_2S to H_2SO_4 produces a sharp increase of dissolution. The effect is attenuated if there is degassing of CO_2 generated by the $H_2SO_4-CaCO_3$ reaction.

There seem to be two settings, where the role of hydrogen sulfide oxidation become an important speleogenetic process. The first is subaqueous dissolution of carbonates near the water table - large rooms of Carlsbad Cavern in New Mexico, USA are supposed to be formed this way. The second setting is the replacement of calcite by gypsum and subsequent removal of the latter occurring above the water table. Such mechanism, termed *replacement corrosion*, was suggested by EGEMEIER (1981) for caves of the Big Horn Basin, USA.

Dissolution due to mixing of waters (CO_2 and H_2S)

Solutional aggressiveness can be renewed or enhanced by mixing of waters of contrasting chemistry, particularly those differing in CO_2 and H_2S content or salinity (BÖGLY, 1964; PALMER, 1991). Mixing of waters having different temperatures produces similar effect. This effect is hold responsible for the development of network maze cave systems in Budapest - Pal-völgyi, Szemlo-hegy, Ferenc-hegy and others (MÜLLER & SÁRVÁRY, 1977; TAKÁCS-BOLNER & KRAUS, 1989).

3. Morphology of hydrothermal caves

Hydrothermal karst, similarly to common one, produces a large variety of cave sizes and morphologies. Hydrothermal solutional features range in size from solutionally-enlarged pores to extensive cave systems with total length of mapped passages exceeding one hundred kilometers.

The comprehensive morphological classification for hydrothermal caves has not been developed yet. Below, I shall discuss several morphologic types of hydrothermal caves reported in the literature.

Being formed at depth due to the action of rising waters, most of hydrothermal caves exhibit a lack of genetic relationships to recharge from overlying or immediately adjacent surfaces (PALMER, 1991). Caves must be uplifted with the area and intersected by surface erosion, common karst, or by drilling, mining, or quarrying to come into view of a researcher. Transitional karst develops on the latest stages of hydrothermal activity. The caves often inherit the overall pattern of systems developed at earlier stages. The exhibit indications of formation close to the Earth's surface (the most clear indication is the presence of waterline or subaerial speleothems).

Isometric rooms

Nearly spherical cave 12 m in diameter was discovered by divers in Heviz lake in Hungary. The bottom of the cave is at -45 m. Two springs of 17 and 40 °C emerge through the cave (PLÓZER, 1977).

Single conduit caves

Single conduit caves are beautifully exemplified by hydrothermal Hellsfont, Spence, and Kane Caves in Wyoming, USA (EGEMEIER, 1981). The caves are nearly-horizontal tube-shaped conduits 60 to 600 m long. They appear to develop in vadose setting, where the H_2S bearing fluids contact with the air and induce replacement-corrosion. The very gentle floor gradients are supposedly controlled by oxygenation and solutional down-cutting, rather than the water table. The caves contain peculiar gypsum crusts and mounds. Thermal springs discharge through the three mentioned caves; several more (inactive) caves having similar pattern are known in the region.

Bush-like caves

Such caves consist of the basal chamber from which a branching pattern of rising passages develops. The branches are composed of coalesced spherical cupolas with typical size of 0,5 to 1,5 m; cupolas terminate most of the branches. Such caves are known in Hungary (MÜLLER & SÁRVÁRY, 1977), Satorkopuszta Cave being the prototype. Another Hungarian example is Batori Cave. This type of caves is believed to be created by delivery of hot water to a single point at the base of carbonate rocks of low fissure frequency. It is taken as an example of monogenic hydrothermal karst, though the exact mode of formation for such caves is debatable. Specifically, one hypothesis ascribes their formation to the convective movement of hot water in phreatic zone (RUDINCKY, 1978), whereas another model invokes convective movement of the moist air above the hot water table, coupled with condensation corrosion (SZUNYOGH, 1982).

Phreatic maze caves

Maze is the most common type of hydrothermal cave systems. Maze caves were typified by PALMER (1991) who distinguished: network caves, anastomotic caves, spongework caves, ramiform caves, and a rudimentary form of the listed types - single-passage caves. These types equally apply to the transitional karst caves.

Network caves are angular grids of intersecting passages formed by the widening of nearly all major fractures within favorable areas of soluble rocks. Closed loops and relatively high and narrow passages are common. Two-dimensional rectilinear maze systems are created where rising water are trapped in densely jointed carbonate rock against relatively impervious bed (FORD & WILLIAMS, 1989). Multi-storey rectilinear network caves occur more frequently. Examples of such a pattern are caves of the Buda Hills, Hungary (Pal-völgyi, Szemlo-hegyi, Ferenc-hegyi), and caves of the Black Hills, South Dakota, USA (Wind Cave, Jewel Cave). Hungarian rectilinear maze caves are

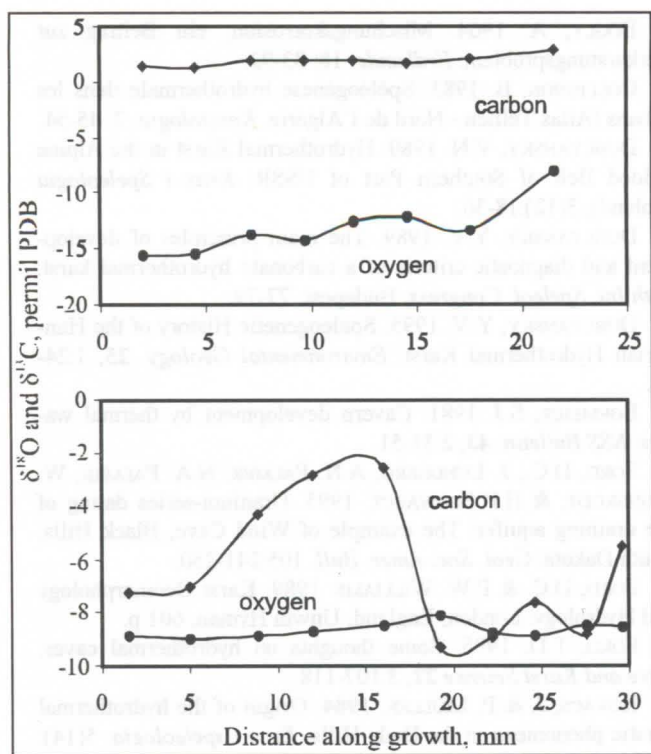

Figure 3 : Stable isotopic profiles along the axis of growth of individual crystals. a - hydrothermal calcite from Nagybanyai Cave, Hungary, formed at 80 (base) to 60 °C (tip); b - transitional calcite from cavities in Esztramos Quarry, Hungary, formed at 35 °C and less.

believed to be formed at the thermal water table, where ascending hot waters meet descending cold ones (KOVÁCS AND MÜLLER, 1984). The walls of Jewel Cave in South Dakota are lined by thick crust of the "nailhead" calcite deposited at temperatures less than 40 °C. Wind Cave contains thinner crust which reflects gradual dewatering of the cave (FORD *et al.*, 1993). Hence, all these caves may be classed as transitional.

Anastomotic caves consist of curvilinear tubes that intersect in a braided pattern with many closed loops. They usually form a two-dimensional array along a single favorable parting or low-angle fracture. Rare three-dimensional variants follow more than one geologic structure. The most prominent example of a supposedly hydrothermal 3-D anastomotic cave is Pobednaya Cave in Kirghizstan, with its 1.5 km of very narrow tube-shaped crawlways (MIKHAILEV, 1989) and unusual barite mineralization.

Spongework caves consist of interconnected solution cavities of varied size in a seemingly random three-dimensional pattern. Such caves appear to form by coalescing of intergranular pores and minor interstices.

Ramiform caves consist of irregular rooms and galleries wandering three-dimensionally with branches extending outward from the main areas of development. Passage interconnections are common, producing a continuous gradation with spongework and network caves.

4. Speleothems

Speleothems may give further insight into the past cave environment. Most reliable data can be obtained from subaqueous deposits (those, formed below the water table). There exist significant intrinsic uncertainty in interpretation of the data on the waterline and subaerial cave deposits, because they are often

formed in the far-from-equilibrium thermodynamic conditions. The following sections compare some properties of transitional karst speleothems with those of the "true" hydrothermal karst speleothems. The generalization is based on the empirical data obtained from 5 hydrothermal karst regions: Northern Algeria, Hungary, Southern Kirghizstan; Crimea (Ukraine), and South Dakota (USA).

Mineralogy

Calcite is the most common mineral of hydrothermal caves developed in carbonate rocks. In addition, such minerals as quartz, barite, fluorite, and sulfides are often reported (we are not considering ore-related hydrothermal karst, where the list of minerals can be quite large). Transitional hydrothermal karst caves do not normally contain any "exotic" minerals.

Character of cave deposits

Large individual calcite crystals, palisade aggregates, thick crusts, sediments reflecting very low (essentially stagnant) hydrodynamic conditions are often found in the deep-seated hydrothermal caves. The size of individual calcite crystals can be large (10-30 and even 100 cm). The crystal morphology is normally simple, dominated by scalenohedron ("dogtooth spar").

By contrast, the deposits of transitional karst caves often reflect unstable environment. Crusts and cave wall linings are typically less thick (thickness normally increases from the water table downwards). Individual crystals are rare. The sizes of crystals in aggregates typically vary from several millimeters to first centimeters. The dominant crystal morphology is a combination of scalenohedron and prism with crystal tip blunted by flat rhombohedron ("nailhead spar").

Sometimes minerals are contaminated by large amount of clay particles (e.g., caves of Nagykömázsa quarry, Hungary), which indicate that these particles were carried by paleowater. The crystals have many defects.

In addition to subaqueous crystals (crusts), two more types of speleothems appear in transitional karst: waterline deposits (rafts, folia, cave cones), and subaerial deposits. These two types are also common in cold karst. Waterline and subaerial deposits of transitional hydrothermal karst are not studied in sufficient detail to allow for developing the diagnostic criteria.

Luminescence

A simple and efficient way of distinguishing hot-temperature vs. moderate temperature calcite is developed by Y. SHOPOV (pers. com.). Being excited with powerful photographic flash, calcite crystals yield glow of different color. Specifically, most of calcites found in hydrothermal caves exhibit short (<0.3 s) orange-red glow, sometimes accompanied by longer (1-20 s) white-blue afterglow. Calcites from transitive karst caves typically yield only long (1-20 s) white-blue glow. Our fluid inclusion studies demonstrated that in one of Hungarian samples calcite which formed at >60 °C has red (+blue) luminescence, whereas the younger part of the same crystal formed at < 60 °C yields only blue glow (DUBLYANSKY, 1995).

Isotopic properties

Calcite crystals from hydrothermal caves typically have $\delta^{18}\text{O}$ varying from -17 to -6 ‰ PDB and $\delta^{13}\text{C}$ from -3 to +3 ‰ PDB. The values of $\delta^{13}\text{C}$ in isotopic profiles taken along the growth axes display small or no variations (figure 3a), which reflects deposition from fluids well equilibrated with the bedrock (long residence time). The typical isotopic values for transitional karst calcites are: $\delta^{18}\text{O}$ from -15 to -8 ‰ PDB and $\delta^{13}\text{C}$ from -9 to -2 ‰ PDB. The $\delta^{13}\text{C}$ may vary significantly in sample along growth

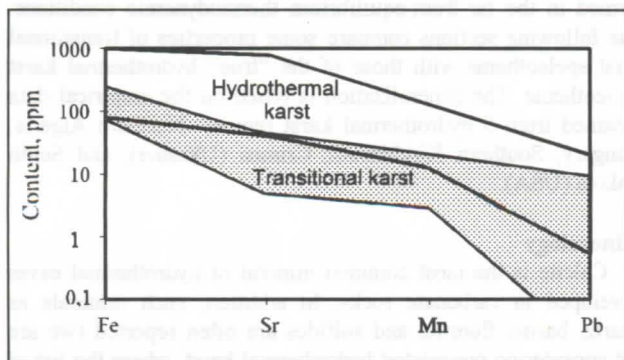

Figure 4 : Typical content of trace elements in calcite from hydrothermal and transitional karst caves

(figure 3b). This depicts the possible input of waters charged with isotopically light soil-derived organic carbon.

Content of trace elements

Hydrothermal cave calcites often have elevated contents of trace elements. For instance, calcites from five studied hydrothermal karst areas contain: Mn 12-120 ppm, Fe 80-900 ppm, Pb 0.5-19 ppm, and Sr 40-770 ppm. The contents of these elements in transitional karst calcites are normally lower: Mn 3-20 ppm, Fe 70-230 ppm, Pb 0-9 ppm, and Sr 5-45 ppm (figure 4)

Temperature and salinity of paleowaters (by fluid inclusions)

Temperatures of hydrothermal karst minerals determined by fluid inclusions vary from 250 to 55 °C. Mineral-forming waters trapped in inclusions contain dissolved salts. The concentrations of the latter in some inclusions reaches tens of wt.% (brines). In contrast, calcites from transitional karst caves contain, mostly, all-liquid inclusions, which indicates temperatures less than approximately 40 °C. In those rare cases when two-phase gas-liquid inclusions were present, the homogenization temperatures of 55 to 30 °C were obtained. The waters trapped in inclusions invariably have low salinity.

5. Conclusion

In many instances transitional karst appears to be a much more powerful speleogenic process than the "true" hydrothermal karst. Many large caves that are called hydrothermal developed at or near the interface between hypogene thermal and epigene low-temperature zones. Such high-gradient environment gives rise to a number of specific speleogenic processes: CO₂ and H₂S related corrosion, mixing/cooling corrosion, condensation corrosion, and replacement corrosion.

Acknowledgments

Part of the field and laboratory work was supported by a Natural Sciences and Engineering Research Council of Canada Research Grant to D.C.Ford. Stable isotopic and some fluid inclusion analyses were carried out during an International Visiting Scientific Fellowship of the Council that was taken up at McMaster University. Dr. D.C.Ford is thanked for his assistance and encouragement.

References

BAKALOWICZ, M., D. FORD, T. MILLER, A. PALMER, & M. PALMER. (1987) Thermal genesis of dissolutional caves in the Black Hills, South Dakota: *GSA Bull.* 99:729-738.

BÖGLY, A. 1964. Mischungskorrosion, ein Beitrag zur Verkarstungsproblem. *Erdkunde.* 18: 83-92.

COLLIGNON, B. 1983. Spéléogénese hydrothermale dans les Bibans (Atlas Tellien - Nord de l'Algérie. *Karstologia.* 2: 45-54.

DUBLYANSKY, V.N. 1980. Hydrothermal Karst in the Alpine Folded Belt of Southern Part of USSR: *Kras i Speleologia (Poland)*, 3(12):18-36.

DUBLYANSKY, Y.V. 1989. The main principles of development and diagnostic criteria of a carbonate hydrothermal karst: *10th Int. Speleol. Congress*, Budapest. 77-79.

DUBLYANSKY, Y.V. 1995. Speleogenetic History of the Hungarian Hydrothermal Karst: *Environmental Geology.* 25, 1:24-35.

EGEMEIER, S.J. 1981. Cavern development by thermal waters: *NSS Bulletin.* 43, 2:31-51.

FORD, D.C., J. LUNDBERG, A.N. PALMER, N.A. PALMER, W. DREIBRODT, & H.P. SCHWARZ. 1993. Uranium-series dating of the draining aquifer: The example of Wind Cave, Black Hills, South Dakota: *Geol. Soc. Amer. Bull.* 105:241-250.

FORD, D.C. & P.W. WILLIAMS. 1989. *Karst Geomorphology and Hydrology*: London, England, Unwin Hyman, 601 p.

FORD, T.D. 1995. Some thoughts on hydrothermal caves: *Cave and Karst Science* 22, 3:107-118.

KOVÁCS, J. & P. MÜLLER. 1984. Origin of the hydrothermal karstic phenomena in the Buda Hills. *Kras i speleologia.* 5(14): 77-84.

MALININ, S.D. 1979. Physical chemistry of hydrothermal systems with carbon dioxide. Moscow: Nauka PH. 111p. (*In Russian*)

MIKHAILEV, V. 1989. Karst of Kirghizia. Frunze: Ilim PH. 146 p. (*In Russian*)

MÜLLER, P. & I. SÁRVÁRY. 1977. Some aspects of development in Hungarian speleology theories during the last 10 years. *Karszt és Barlang.* Special Issue: 53-60.

PALMER, A.N. 1991. Origin and morphology of limestone caves: *GSA Bull.* 103:1-21.

PLÓZER, I. 1977. Situation of Hungarian cave diving in 1976. *Karszt és Barlang.* Special Issue: 67-69.

RUDINCKY, J. 1978. Role of convection in shaping subterranean karst forms. *Pr. nauk Usl.* Katowicwe. 280: 92-101.

SZUNYOGH, G. 1982. Theoretical problems of dissolution related with spherical niches formation. *Karszt és Barlang.* 2: 83-88 (*In Hungarian*)

TAKÁCS-BOLNER, K. & S. KRAUS. 1989. The results of research into caves of thermal water origin. *Karszt és Barlang,* Special Issue: 31-38.

WORTHINGTON, S.R.H. & D.C. FORD. 1995. High sulfate concentration in limestone springs: An important factor in conduit initiation? *Environmental Geology.* 25, 1: 9-15.

Régime hydrologique et flux de matières dissoutes du karst de São Domingos, Goiás, Brésil

par Jean Loup Guyot ⁽¹⁾, Leonildes Melo Filho ⁽²⁾, & Augusto Auler ⁽³⁾

1 : ORSTOM, CP 09747, 70001-970 Brasília, DF, Brésil

2 : Instituto de Geociências, Universidade de Brasília, CP 4383, 79919-970 Brasília, DF, Brésil

3 : University of Bristol, Angleterre

Abstract

The karstic massif of São Domingos, located in the Northern part of the state of Goiás, is formed by a carbonate series of the Precambrian, with a thickness of about a hundred meters. This "Serra do Calcário" is crossed from East to West by the exogenous watercourses provenient from the Cretaceous sandstone series of the "Serra Geral" of Goiás.

The study of the pluviometric and hydrometric data available has made possible the characterisation of the rivers hydrological regimes of this region, and consequently made clear the important phenomena of stream piracy of the "Serra Geral" towards the "Serra do Calcário" and the Rio Paranã, former of the Tocantins river.

A control of the inflow and the outflow from the massif, allowed in July 94, the French-Brazilian caving expeditions to appreciate the hydrogeochemical role of the "Serra do Calcário" over the rivers of the region. The results obtained, however temporary, make it possible to move towards an idea of the magnitude of the dissolution rate of the São Domingos tropical karst.

Résumé

Le massif karstique de São Domingos, situé au nord de l'état de Goiás, est constitué d'une série carbonatée du Précambrien d'une centaine de mètres d'épaisseur. Cette « Serra do Calcário » est traversée d'est en ouest par des cours d'eau exogènes issus des séries gréseuse du Crétacé de la « Serra Geral » de Goiás.

L'étude des données pluviométriques et hydrométriques disponibles a permis de caractériser les régimes hydrologiques des rivières de la région, et mettre ainsi en évidence d'importants phénomènes de capture souterraine des eaux de la « Serra Geral » vers la « Serra do Calcário » et le rio Paranã, formateur du fleuve Tocantins.

Un contrôle des flux entrants et des flux sortants du massif, a permis en juillet 94 (Expéditions spéléologiques franco-brésilienne GOIÁS 94) d'apprécier le rôle hydrogéochimique de la « Serra do Calcário » sur les rivières de la région. Les résultats obtenus, bien que provisoires, permettent d'avancer un ordre de grandeur de la vitesse de dissolution du karst tropical de São Domingos.

1. La région de São Domingos

La région de São Domingos est située à 300 km au Nord de Brasília, dans l'état de Goiás, qui avec les états voisins du Mato Grosso du Sud, du Mato Grosso et du District Fédéral, forment la région Centre-Ouest du Brésil. Cette région, qui fait partie de l'ensemble morphologique du « Planalto Central » brésilien, est caractérisée par une végétation d'arbustes et de graminées : le « Cerrado ». Trois domaines lithologiques distincts s'individualisent : la « Serra Geral de Goiás » constituée de grès du Crétacé, le massif calcaire de São Domingos « Serra do Calcário », et la surface d'érosion sur laquelle est située la ville de São Domingos (DUTRA, 1997).



Figure 1 : Localisation de la région de São Domingos

Les eaux de pluie absorbées par le massif gréseux de la « Serra Geral » résurgent à la base des falaises de grès et forment des rivières qui s'écoulent vers l'ouest et viennent buter contre la lisière de la « Serra do Calcário ». Ces rivières traversent alors le massif calcaire par des cours souterrains et vont rejoindre le rio Paranã, formateur du grand rio Tocantins (LE BRET, 1991).

La région karstique de São Domingos peut être définie comme un vaste « causeuse », ensemble karstifié présentant un amont à cours d'eau exogènes constitués, de fort débit (de plusieurs centaines de l/s à plus de 5m³/s en étiage) qui, en traversant le massif calcaire, se perdent dans d'impressionnantes goules. Ces dernières se développent en galerie-tunnel de grand diamètre. Ces mêmes cours d'eau réapparaissent plusieurs kilomètres en aval par de puissantes résurgences dont certaines sont pénétrables (RODET, 1997).

2. Histoire géologique

Les roches qui affleurent dans la région sont essentiellement le socle cristallin granito-gneissique et les couvertures protérozoïques et crétacées. Les roches du socle cristallin se sont formées il y a plus de 2.5 milliards d'années. Sur ces séries, il y a 1 milliard d'années environ, des sédiments ont commencé à se déposer, qui constituent aujourd'hui les roches calcaires du Groupe Bambuí. Cette sédimentation a pris fin il y a 600 millions d'années, et cet intervalle de temps a reçu le nom de Néoprotérozoïque. Cet épisode est caractérisé par une grande concentration de micro-organismes marins, producteurs d'oxygène et de carbonate de calcium, qui sont à l'origine d'une fantastique production de roches calcaires qui est une des caractéristiques du Groupe Bambuí. La fin du dépôt de ces

sédiments (il y a 600 millions d'années) a été marquée par l'orogénèse Brasilianno/Pan-Africaine. Le passage de l'ère Néoprotérozoïque à l'ère Paléozoïque est marqué par l'apparition de nouvelles formes de vie marine que sont les organismes pluricellulaires. Probablement, à cette époque, le Supercontinent Gondwana était émergé, entraînant le début de l'altération des roches protérozoïques. Cette érosion a continué durant le Paléozoïque et s'est intensifiée à la fin du Mésozoïque. Les grès de la formation Urucuia se sont déposés, il y a 135 millions d'années. La sédimentation de cette série détritique s'est effectuée dans un milieu essentiellement désertique. Dans la région, elle présente 300 m d'épaisseur, et recouvrait probablement le Groupe Bambuí. L'ouverture de l'Océan Atlantique a provoqué la séparation de l'Afrique et de l'Amérique. Ce phénomène, associé aux changements climatiques affectant la nouvelle Amérique du Sud, est à l'origine d'une longue période d'érosion qui a débuté il y a 60 millions d'années. Depuis cette époque, et jusqu'à aujourd'hui, les roches du groupe Bambuí ont été soumises aux phénomènes d'altération chimique et mécanique. L'âge des systèmes karstiques est très difficile à estimer, mais ils ont vraisemblablement moins de 60 millions d'années (MELO FILHO L., 1997).

3. Climat

L'ensemble de la région de São Domingos est soumise à un climat tropical chaud sub-humide, caractérisé par un hiver sec et un été pluvieux. Les données climatologiques de la station de Posse permettent de connaître les grands traits du climat de la région de São Domingos. La température moyenne annuelle de l'air est de 23.3°C., et les températures extrêmes enregistrées sont de 7.0°C pour les minima et 36.8°C pour les maxima. Avec une insolation moyenne de 2424 heures par an et une humidité relative de 67%, la station de Posse reçoit 1538 mm de pluie par an. L'essentiel de ces précipitations s'observe durant les 5 mois de novembre à mars, qui totalisent 80% des précipitations annuelles. Par contre, les 3 mois de juin à août ne représentent que 1% environ de la pluviométrie annuelle, le mois de juillet étant statistiquement le mois le plus sec. Les données pluviométriques de 161 stations du DNAEE du quadrant 11-16° de latitude Sud / 44-49° de longitude Ouest, ont été utilisées pour tracer la carte des pluies moyennes annuelles de la région. La tendance générale observée est un gradient positif d'Est en Ouest, avec des précipitations inférieures à 1000 mm par an sur les marges orientales de la Serra Geral (Bassin du Rio São Francisco), et des valeurs supérieures à 1500 mm sur la partie occidentale. La pluviométrie moyenne annuelle sur la Serra do Calcário de São Domingos doit être de l'ordre de 1300 mm par an (Guyot, 1997).

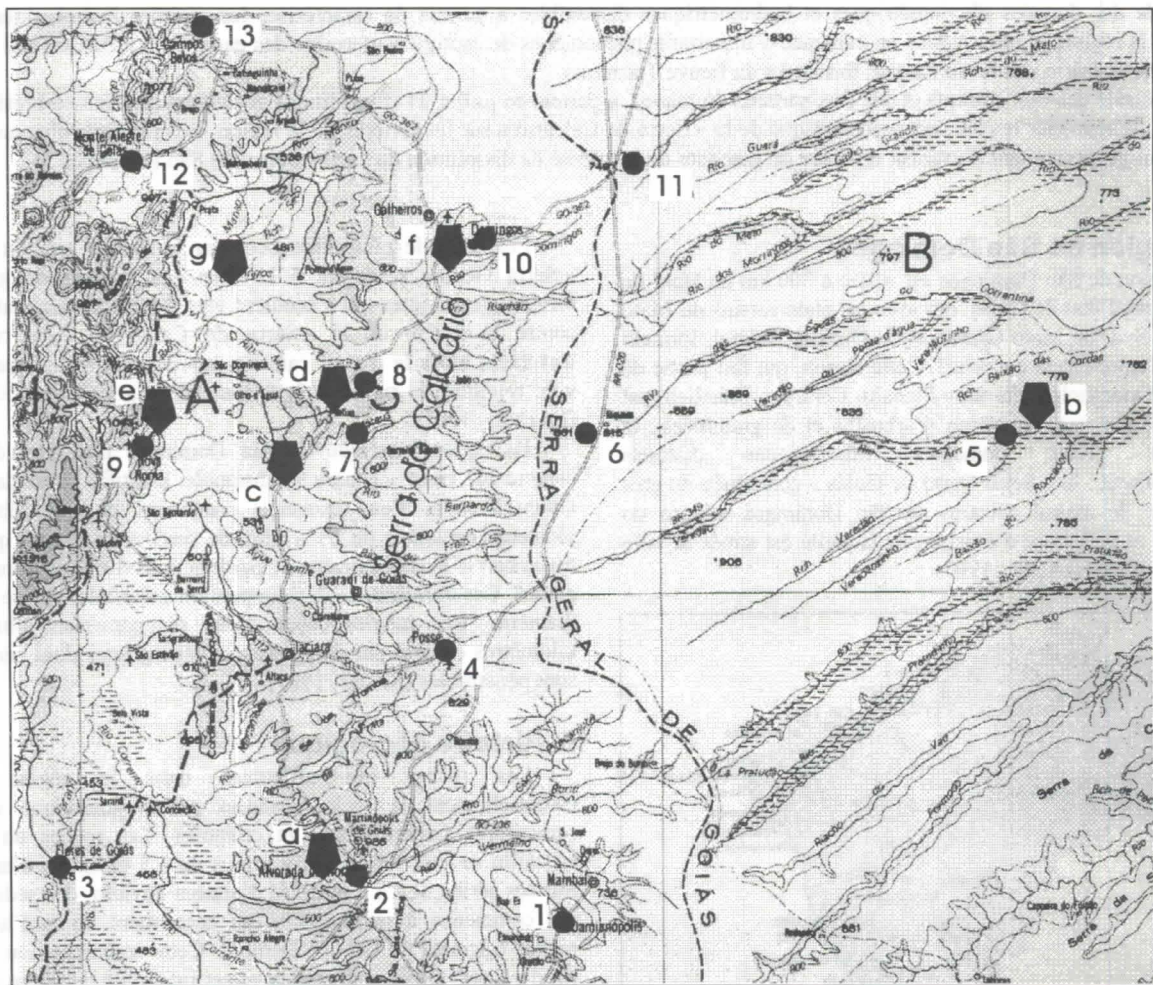

Figure 3 : Carte de la région de São Domingos (● station pluviométrique, ◆ station hydrométrique)

[1: Damianópolis, 2: Alvorada do Norte, 3: Flores de Goiás, 4: Posse, 5: Arrojoândia, 6: Fazenda Planalto, 7: Fazenda Ingazeiro, 8: São Vicente, 9: Nova Roma, 10: São Domingos, 11: Fazenda Prainha, 12: Monte Alegre de Goiás, 13: Campos Belos, a: Rio Corrente à Alvorada do Norte, b: Rio Arrojado à Arrojoândia, c: Rio São Mateus à Puente São Mateus, d: Rio São Vicente à São Vicente, e: Rio Paranã à Nova Roma, f: Rio São Domingos à São Domingos, g: Rio São Domingos à Fazenda Veneza].

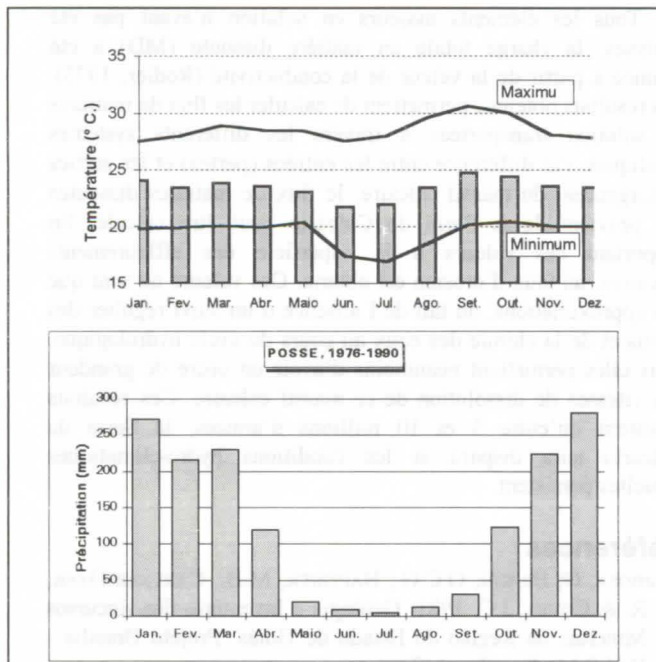

Figure 3 : Caractéristiques climatiques de la station de Posse (Données INEMET).

4. Hydrologie

La distribution des débits moyens mensuels présente pour l'ensemble des stations un régime tropical austral, caractérisé par une saison de hautes eaux de novembre à avril, et une période de basses eaux de juin à octobre. Toutefois, deux types d'hydrogrammes s'individualisent nettement : 1. les cours d'eau issus des formations gréseuses de la Serra Geral de Goiás avec une faible variabilité des débits au cours de l'année, 2. les formateurs du Rio Paranã à une certaine distance de la Serra Geral. Le rapport des débits extrêmes mensuels RQm (débit moyen mensuel maximum / débit moyen mensuel minimum) est toujours inférieur à 2 pour les rivières issues de la Serra Geral. Ce rapport RQm varie de 2 à 9 sur les autres cours d'eau du bassin du Paranã, avec des valeurs plus faibles dans les bassins proches de la Serra Geral. La comparaison des hydrogrammes des rios Paranã à Ponte Paranã (31 370 km²) et Corrente à Porto Novo (31 120 km²) dont les bassins sont de même taille, est particulièrement démonstrative.

La Serra Geral de Goiás est un aquifère poreux de grande extension qui joue un rôle de réserve hydrique en modulant les débits aux exutoires au cours du cycle hydrologique. Cette caractéristique permet aux cours d'eau de la région d'avoir un débit d'étiage soutenu, alors que les précipitations sont pratiquement nulles durant les 5 mois de la saison sèche. Ce rôle régulateur de la Serra Geral sur les débits journaliers s'observe particulièrement bien dans la région de São Domingos. A São Domingos, le débit de la rivière est quasiment constant, mis à part quelques pics de courte durée lors de la saison pluvieuse, dus aux pluies sur le bassin situé entre la résurgence et la station hydrométrique. A São Vicente et à Ponte São Mateus, le même phénomène est observé, mais avec des pics beaucoup plus importants, bien que toujours de courte durée. Cette réponse plus importante en crue provient d'une plus grande extension des bassins compris entre la Serra Geral et les stations de mesure. Certaines crues importantes peuvent avoir lieu en dehors de la saison des pluies, d'avril à octobre, phénomène à prendre en considération lors des explorations des rivières souterraines. Le débit spécifique (qs) observé sur les cours d'eau du bassin du Rio São Francisco est de l'ordre de 9 l/s.km², valeur qui peut être considérée comme représentative des

rivières issues de la Serra Geral. Les formateurs du Rio Paranã présentent un qs supérieur, de l'ordre de 12 l/s.km², du fait d'une pluviométrie plus importante. Par contre, certains de ces formateurs montrent un qs anormalement élevé (rios São Domingos, São Vicente, São Mateus) probablement lié à une sous estimation de la superficie des bassins versants. Effectivement, ces cours d'eau sont issus de résurgences localisées au pied du versant occidental de la Serra Geral, qui drainent les eaux souterraines de cet immense aquifère, bien au delà des limites topographiques des bassins versants de surface (Le Bret, 1991). Il s'agit d'un bel exemple de capture des eaux du bassin du Rio São Francisco vers le bassin du Rio Tocantins-Paraná. Pour le Rio São Domingos, c'est environ 1500 km² qui seraient ainsi capturés, alors que le bassin topographique n'est que de 320 km². De même, pour le Rio São Mateus (systèmes São Bernardo - Palmeiras, Terra Ronca - Malhada, et São Mateus - Imbira) et le Rio São Vicente (systèmes São Vicente et Angélica - Bezerra), les superficies capturées seraient de l'ordre de 700 km².

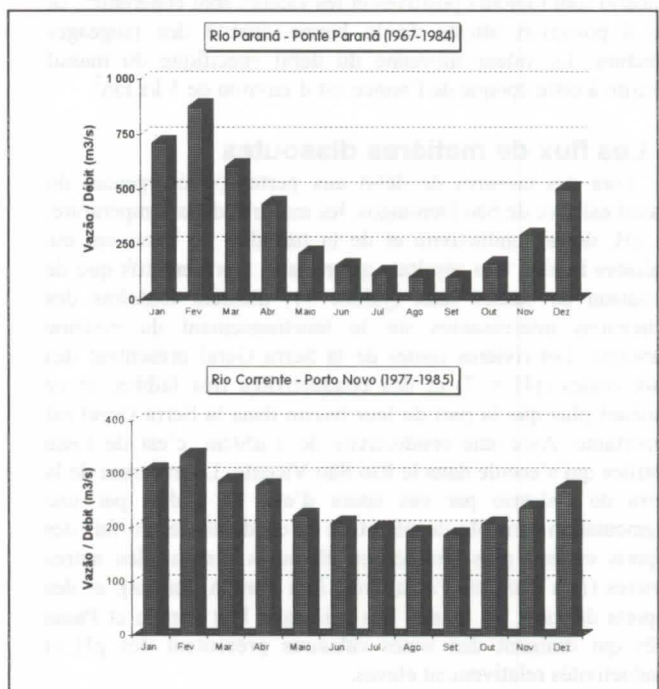

Figure 4 : Débits moyens mensuels (Données DNAEE).

En juillet 94, au cours de l'expédition spéléologique Franco-Brésilienne GOIÁS 94, une équipe a réalisé des mesures de débit, relevé un certain nombre de paramètres physico-chimiques, et effectué un échantillonnage d'eau sur les différentes rivières traversant le karst de São Domingos. Le mois de juillet 94 est caractérisé sur tous les postes pluviométriques de la région par une absence de pluie, faisant suite à un mois de juin pluvieux. Les débits des cours d'eau de la région ne seront donc pas à leur plus bas niveau d'étiage. Les débits ont été mesurés sur 15 cours d'eau par exploration du champ des vitesses dans la section à l'aide d'un micro-moulinet. Pour chaque rivière, les vitesses ont été mesurées sur plusieurs verticales (de 4 à 18, suivant la largeur). Les conditions de travail avec cet équipement étaient parfois limite, notamment pour les rios São Vicente, Terra Ronca et São Bernardo (profondeur > 80 cm, vitesses > 1 m/s).

Le graphique débit des pertes vs. superficie individualise clairement les cours d'eau issus de la Serra Geral des autres cours d'eau, et il est manifeste que la Serra Geral contribue au débit de ces rivières, bien au delà des limites supposées de ces bassins versants.

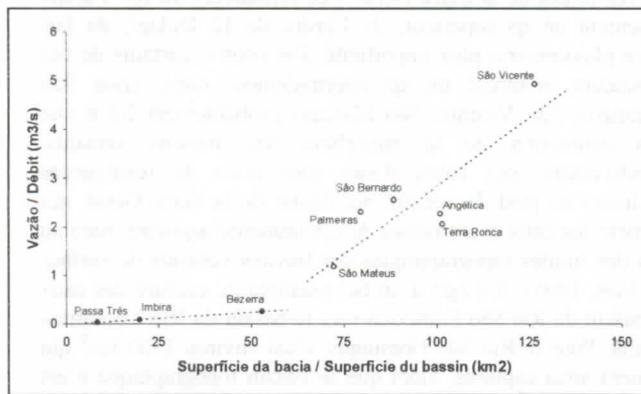

Figure 5 : Débit des pertes vs. superficie du bassin.

A partir des débits aux résurgences et aux pertes, un bilan hydrique 'entrée-sortie' du massif calcaire a pu être réalisé. Les différences de débit entre entrées et sorties de la Serra do Calcário sont toujours positives et les valeurs sont cohérentes, ce qui a posteriori atteste de la bonne qualité des jaugeages effectués. La valeur moyenne du débit spécifique du massif calcaire à cette époque de l'année est d'environ de 5 l/s.km².

5. Les flux de matières dissoutes

Lors des mesures de débit aux pertes et résurgences du massif calcaire de São Domingos, les mesures de la température, du pH, de la conductivité et de la turbidité de l'eau ont été réalisées in situ. Ces résultats qui ne sont représentatifs que de la saison de basses eaux (juillet 94) donnent toutefois des indications intéressantes sur le fonctionnement du système karstique. Les rivières issues de la Serra Geral présentent des eaux acides (pH < 7) et des conductivités très faibles, et ce d'autant plus que la part de leur bassin dans la Serra Geral est importante. Avec une conductivité de 1 µS/cm, c'est de l'eau distillée qui s'écoule dans le Rio São Vicente. La traversée de la Serra do Calcário par ces cours d'eau se traduit par une augmentation sensible du pH et de la conductivité, du fait des apports en eau plus chargée en éléments dissous des autres rivières (rios Bezerra, Passa Três, Pau Pombo, Imbira), et des apports du karst lui-même. Les ruisseaux Pau Pombo et Passa Três qui drainent des zones calcaires présentent des pH et conductivités relativement élevés.

Tous les éléments majeurs en solution n'ayant pas été analysés, la charge totale en matière dissoute (MD) a été estimée à partir de la valeur de la conductivité (Rodier, 1975). Les résultats obtenus, permettent de calculer les flux de matières en solution transportées à travers les différents systèmes karstiques. Par différence entre les entrées (pertes) et les sorties (résurgences) du massif calcaire, le flux de matières dissoutes qui provient de la Serra do Calcário peut être calculé. En rapportant ces valeurs à la superficie des affleurements calcaires, un taux d'érosion est obtenu. Ces valeurs ne sont que des approximations, du fait de l'absence d'un suivi régulier des débits et de la chimie des eaux au cours du cycle hydrologique, mais elles permettent néanmoins d'avoir un ordre de grandeur des vitesses de dissolution de ce massif calcaire. Ces résultats montrent qu'entre 5 et 10 millions d'années, la Serra do Calcário aura disparu si les conditions hydro-climatiques actuelles persistent.

Références

- BARBOSA, O.; BRAUN, O.C.G.; BAPTISTA, M.B.; CARTNER-DYER, R. & COTTA, J.C. 1981. Geologia e Inventário dos Recursos Minerais da Região do Estado de Goiás. Projeto Brasília - D.N.P.M., Brasília, 147 pp.
- DUTRA, G. 1997. Geografia da região. In: Expedições franco-brasileiras GOIÁS 94 & 95, GBPE-GREGEO-GSBM, Brasília : 15-19.
- GUYOT, J.L., AULER, A., OGA, D., OBSTANCIAS, I., APPAY, J.L. 1997. Balanço hidrogeoquímico. In: Expedições franco-brasileiras GOIÁS 94 & 95, GBPE-GREGEO-GSBM, Brasília : 52-58.
- GUYOT, J.L. 1997. Hidroclimatologia da região. In: Expedições franco-brasileiras GOIÁS 94 & 95, GBPE-GREGEO-GSBM, Brasília : 43-51.
- LE BRET, M. 1991. Le district spéléologique de São Domingos, Etat de Goiás, Brésil. In: Actes de la Première rencontre d'Octobre, N° 1, Spéléo Club de Paris, Paris : 41-55.
- MELO FILHO, L. 1997. Aspectos geológicos. In: Expedições franco-brasileiras GOIÁS 94 & 95, GBPE-GREGEO-GSBM, Brasília : 20-23.
- RODET, J. 1997. Registros carstológicos. In: Expedições franco-brasileiras GOIÁS 94 & 95, GBPE-GREGEO-GSBM, Brasília : 24-42.
- RODIER, J. 1975. L'analyse de l'eau. Ed. Dunod, Paris, 629 p.

Bilan des flux de matières en solution [S Tot. = superficie totale du bassin, S Calc. = superficie des calcaires dans le bassin, Q = débit, Cond. = conductivité, MD = matières en solution, QD = flux de MD, QD Calc. = flux de MD qui provient des calcaires, ER = taux d'érosion, ER Calc. = taux d'érosion pour les calcaires].

Rivière	Lieu	S Tot. (km ²)	S Calc. (km ²)	Q (m ³ /s)	Cond. (µS/cm)	MD (mg/l)	QD (t/d)	QD Calc. (t/d)	ER (t/km ² .ano)	ER Calc. (t/km ² .ano)
Angélica	Perte	101		2.27	8	6	1.1		4	
Bezerra	Perte	53		0.24	29	20	0.4		3	
Angélica	Résurgence	168	14	2.57	18	12	2.7	1.2	6	33
São Vicente	Perte	127		4.91	1	1	0.3		1	
Passa Três	Perte	9		0.02	247	170	0.3		14	
São Vicente	Résurgence	157	22	5.01	27	19	8.0	7.4	19	126
São Mateus	Perte	72		1.17	9	6	0.6		3	
Imbira	Perte	20		0.08	80	55	0.4		7	
São Mateus	Résurgence	114	22	1.27	92	63	7.0	5.9	22	97
Terra Ronca	Perte	102		2.05	17	12	2.1		7	
Terra Ronca	Résurgence	116	14	2.20	30	21	3.9	1.8	12	48
Palmeiras	Perte	80		2.32	4	3	0.6		3	
São Bernardo	Perte	89		2.57	13	9	2.0		8	
São Bernardo	Résurgence	189	20	5.03	29	20	8.7	6.1	17	110

The influence of pre-existing and orogenic faults to the structures on modern groundwater circulation of two karstic aquifers in the southernmost anticline (Weissenstein) of the folded Jura (Switzerland)

by Th. Herold *, W. Balderer * & P. Jordan **

* Engineering Geology, Swiss Federal Institute of Technology, Zürich, Switzerland

** Water Management Authority, Canton of Solothurn, Switzerland

Abstract

The southernmost WSW-ENE striking anticline complex of the Jura fold and thrust belt (Weissenstein) represents a large fault affected two aquifers anticline. The modelling of its geometry and the results of multitracer experiments showed the strong influence of pre-existing faults on the function of the karst systems. The course of the part of the Weissenstein anticline between the Oensingen-Balsthal defile and the Weissenstein railway tunnel is not in a straight line. Because of pre-existing faults, the anticline is bent along two lines. This gives a pathway in the stretched part of the anticline for the karst water to pass by flow paths perpendicular to the anticline from deep in the core through the aquiclude interlayers.

1. General overview

For this study, a 22 km long and 8 km wide area within the Weissenstein- and Farisberg anticline complex of the folded Jura was selected. The western border is formed by the gorge of Gänsbrunnen and the Weissenstein tunnel; the eastern border corresponds to the gorge of Oensingen-Balsthal and Balsthal-Mümliswil (Fig. 1). The study area is hydrological closed and Lüscher (1975) has studied the hydrologic parameters. His project was based on already existing hydrological monitoring systems of the Canton of Solothurn and the SMA (Zürich). Since this thesis was finished monitoring has been broadly expanded by the Canton of Solothurn for hydrological observations as well as for certain springs. In the same way, the behaviour of the tectonic has been extensively studied (WIEDENMAYER, 1923, MEIER, 1977, LAUBSCHER & HAUBER, 1982, TSCHUMI, 1983, LAUBSCHER & PFIRTER, 1984, MEYER, 1977, KREBS, 1984, ALLENBACH, 1994, BUXTORF, 1908, BALMER, 1989). Especially TH. BITTERLI (1990, 1992) examined for tectonic research a portion of the study area within the scope of his dissertation.

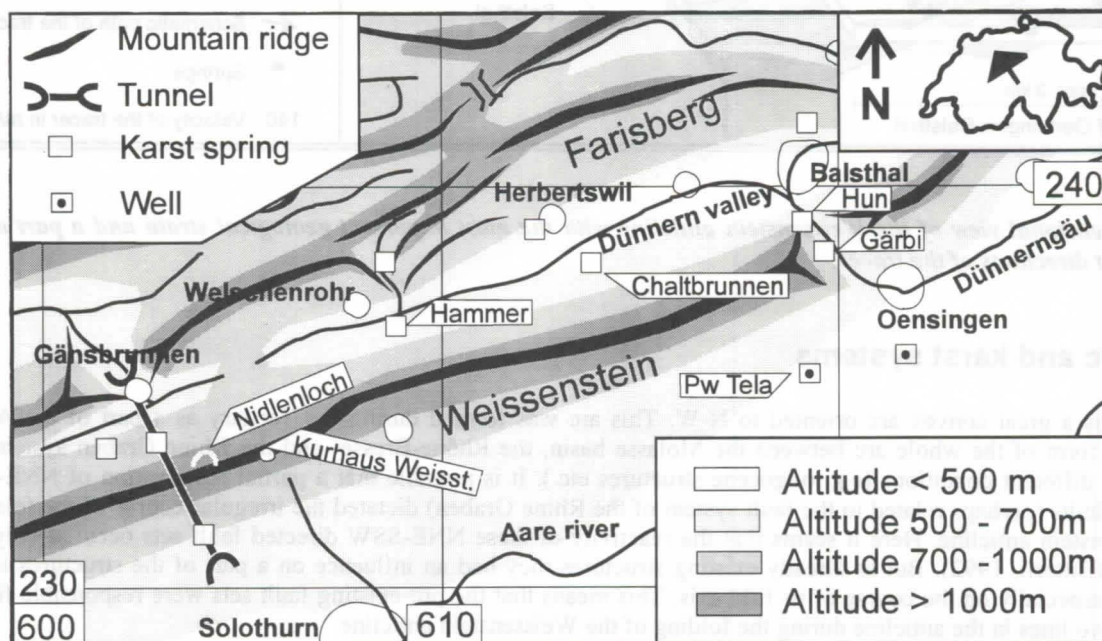

Fig. 1: Geographic situation with the most important springs. The studied area contains the Weissenstein and Farisberg anticlines as well as the syncline of Balsthal.

Furthermore in the last few years a lot of new information has been obtained by other researchers. In the frame of the thesis of Th. Herold, the aquifer in the quaternary of the Dünner valley was simulated by two research projects

(UNMÜSSIG, 1995, REGLI, 1997) with the ASM-program (KINZELBACH, 1992, KINZELBACH et al., 1995), with special attention paid to the intrusion of subsurface karstsprings into this aquifer. The part of the Dünnergäu south of the Weissenstein-anticline was also simulated (GEOTECHNISCHES INSTITUT, 1996).

Furthermore in the summer of 1994 and 1995 two multitracer experiments could be conducted. During these experiments eight different tracers were brought into the systems at 22 different locations (13 in 1994, 9 in 1995), so that a large amount of data, especially for the Weissenstein anticline, could be collected over a time of four months. The data are stored in the data bank of the GIS-system (Arc Info) of the Canton of Solothurn. From the results valuable information has been gained about the whole system:

Generally the overall direction of the water course is obviously from west to east in the limestones of the Malm as well as in the limestones of the Dogger (only in the subregion of the subsurface watershed, in vicinity of the gorge of Gänsbrunnen the water flows over a short distance from west to east / Fig.2).

The subsurface watershed was determined to lie on the western part of the study area. This was observed in the region of the Weissenstein tunnel. The tracers introduced into the groundwater in the western part of the Nidlenloch caves (paleokarstsystem) emerged only in the springs in the Weissenstein tunnel, those introduced in the eastern half were found in springs further east (Fig.2).

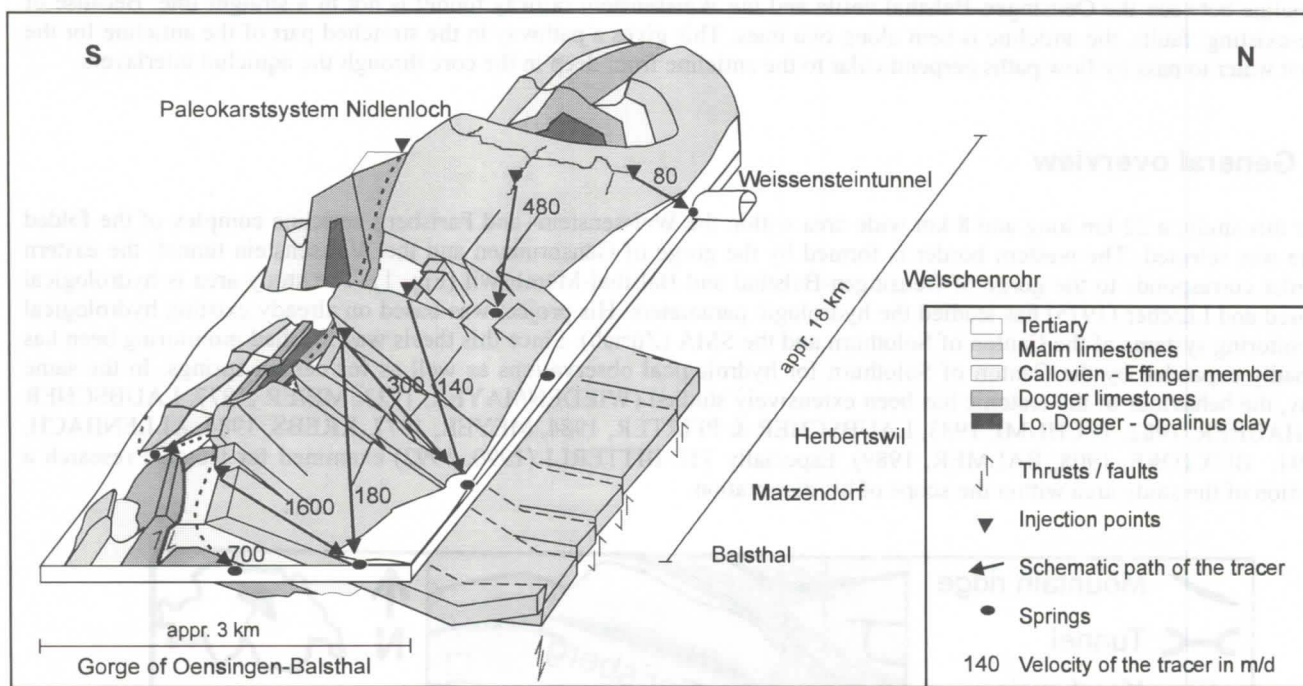

Fig. 2: 3 dimensional view of the Weissenstein anticline with the most important geological strata and a part of the current directions of the tracer.

2 Tectonic and karst systems

The Jura forms a great convex arc oriented to N-W. This arc was formed during the Tertiary as a part of the Alpine orogeny. The form of the whole arc between the Molasse basin, the Rhône-Bresse- and the Rhine Graben system was influenced by different conditions (e.g. oligocene structures etc.). It is possible that a partial reactivation of NNE-SSW directed tear faults (prehaps related to the fault system of the Rhine Graben) dictated the irregular course of the fold axis in the Weissenstein anticline. Here it seems that the reactivity of these NNE-SSW directed fault sets occurred only in a small degree (Bitterli, 1992). But as already existing structures they had an influence on a part of the structures in this anticline and especially on the course of its fold axis. This means that the pre-existing fault sets were responsible for the bends along two lines in the anticline during the folding of the Weissenstein anticline

The first of these bends produces a lateral pinch in the north side of the anticline. The corresponding thrust or fault sets seem to be directed to the east. They pass the Hun spring which drains the northern Weissenstein flank from the gorge until to the Chaltbrunnen spring. In the Hun spring only the tracers induced in the Malm limestones were observed. On the southernmost part of this bend the flank is stretched by an extensional tectonic mechanism. As the tracerexperiments showed, a part of the tracer passed rapidly from the core of the anticline through the impermeable layers of the Callovien, Effinger members and possibly through a part of the Molasse directly into the groundwater system of the Dünnergäu. Tracer induced into the core of the anticline were observed along this thrust line only on this southernmost side by a few springs at the flank, but also very soon in a well in the Dünnergäu (Fig.2 + 3). This was also demonstrated in a two-

dimensional simulation-model of the Dünnergäu, where it was necessary to give respect to a greater karst water seepage into the ground-water system near this line (GEOTECHNISCHES INSTITUT, 1996).

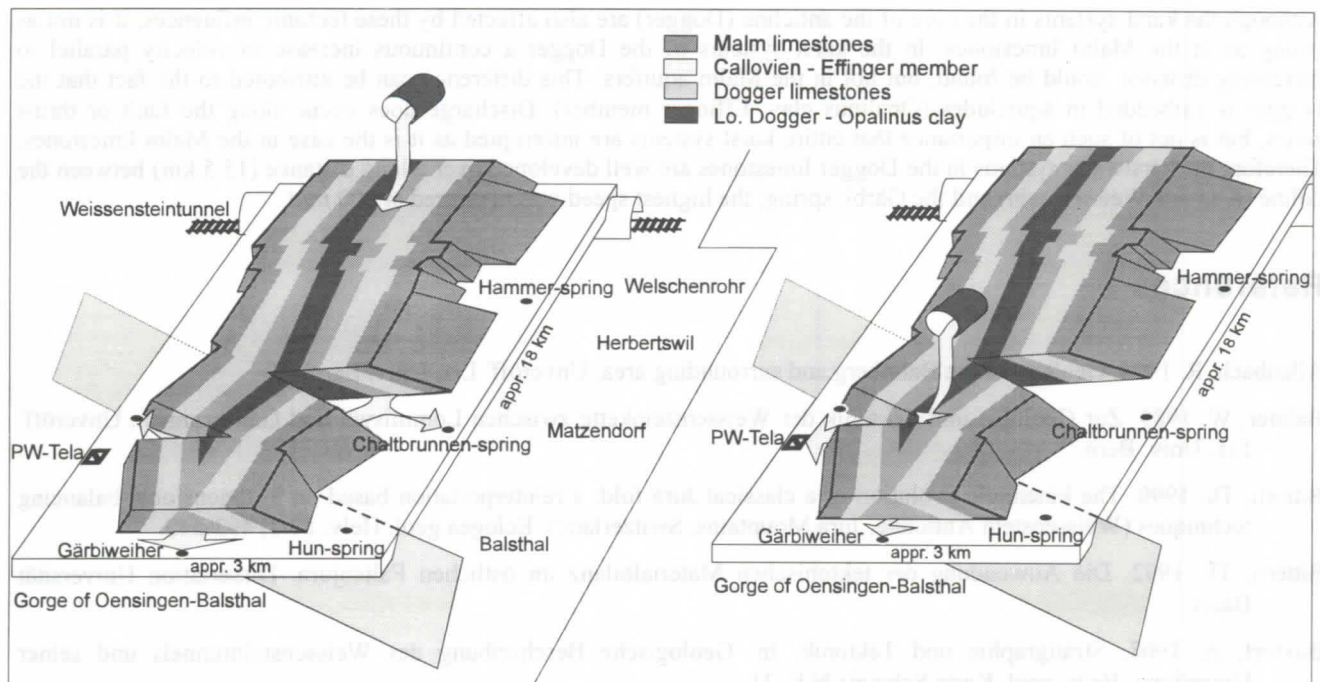

Fig. 3: Schematic crosscut (horizontal) through the Weissenstein anticline for demonstrating the cracking of the limbs as an effect of the bended anticline chain. On the left side was the tracer induced at the Kurhaus Weissenstein, on the right side was the tracer induced near the gorge of Oensingen - Balsthal.

The second line occurs in the middle of the anticline. Here, it bends on the other side in comparison to the first line near the gorge of Oensingen-Balsthal. On the northern flank of the Weissenstein it is probable that a similar extensive tectonic mechanism exists, as described above. In this way flow path crossing the anticline from the interior through the impermeable layers into the Dünnergäu valley is made possible for the northern part of the Weissenstein anticline. This was proved by the tracer experiments for the Chaltbrunnen spring in the Dünnergäu valley. The tracer induced into the anticline core at the Kurhaus Weissenstein appeared in Gärbi-Weiher, situated in the Dogger limestones in the gorge (Fig. 2 + 3) and in the Chaltbrunnen spring, situated in the Malm limestones (Fig. 3).

But for this second line on the southern flank of the Weissenstein it is not possible to determine any corresponding thrusts. It may be that they do not exist because the tectonic mechanisms are not exactly identical, or that existing thrusts or faults are integrated into the western situated fault zones. The most probable explanation is that they are hidden under the great rockslide masses of the south limb.

3 Conclusion

Interpreting the results of the multitracer experiment and the special character of the fault zones, a first interpretation of the tectonic influence on the karst systems in the Dogger and Malm aquifer is possible:

The southernmost WSW-ENE striking anticline complex of Jura fold and thrust belt (Weissenstein) represents a large fault affected two aquifers anticline. In the part of the Weissenstein anticline between the Oensingen-Balsthal defile and the Weissenstein railway tunnel north of Solothurn the course of the fold axis is not in a straight line. This is caused by tectonic conditions. During the folding of this anticline this irregular course was dictated by pre-existing NNE-SSW directed faults. The modelling of its geometry in the third dimension and the results of multitracer experiments has shown the strong influence of these pre-existing faults on the function of the karst systems:

- 1) Through these forces, the fold axis of the Weissenstein is bent along two lines. They lead on the stretched part of the anticline to an open pathway for the existing karst systems both on the surface (Malm) and in the anticline-core (Dogger), which is normally separated by aquicludes. In this way it is possible for the water to pass from the core by flow paths perpendicular to the anticline through the impermeable interlayers and to get into the Dünnergäu valley or Dünnergäu before reaching the topographical deepest point in the gorge of Oensingen by Gärbi Weiher.
- 2) In the limestones of the Malm they cause an intense interruption and drainage of the karst systems of the Malm

limestones. This thrusts or faults are always related to the great springs. As the tracer experiments have shown not only the karst waters of the Malm limestones are lateral drained but also a small portion of the largest karstsystem in the Dogger

Although the karst systems in the core of the anticline (Dogger) are also affected by these tectonic influences, it is not as strong as in the Malm limestones. In the karst systems of the Dogger a continuous increase in velocity parallel to increasing distance could be found, but not in the Malm aquifers. This difference can be attributed to the fact that the Dogger is embedded in aquicludes (Opalinus clay, Effinger member). Discharge does occur along the fault or thrust zones, but is not of such an importance that entire karst systems are interrupted as it is the case in the Malm limestones. Therefore the karstwater systems in the Dogger limestones are well developed over a long distance (15.5 km) between the doline (Kurhaus Weissenstein) and the Gärbi spring; the highest speed was measured at 800 m/d.

References

- Allenbach, R. 1994. Geology of the Balmberg and surrounding area. Unveröff. Liz. Univ. Bern.
- Balmer, W. 1989. Zur Geologie und Tektonik der Weissensteinkette zwischen Lommiswil und Gänsbrunnen. Unveröff. Liz. Univ. Bern.
- Bitterli, Th. 1990. The kinematic evolution of a classical Jura fold: a reinterpretation based on 3-dimensional balancing techniques (Weissenstein Anticline, Jura Mountains, Switzerland). *Ecloga geol. Helv.* 83/3, 493-512.
- Bitterli, Th. 1992. Die Anwendung der tektonischen Materialbilanz im östlichen Faltenjura. Dissertation Universität Basel.
- Buxtorf, A. 1908. Stratigraphie und Tektonik. In: Geologische Beschreibung des Weissensteintunnels und seiner Umgebung. *Beitr. geol. Karte Schweiz N.F.* 21.
- Geotechnisches Institut, 1996: Grundwassergebiet Dünnerngäu/Aaregäu, Strömungsgrobmodell und Pflichtenheft für Detailmodell. Bericht Nr. 161.0257.
- Kinzelbach, W. 1992. Numerische Methoden zur Modellierung des Transports von Schadstoffen im Grundwasser. Oldenburg Verlag München, Wien, 2. Auflage.
- Kinzelbach W. & R. Rausch 1995. Grundwassermodellierung. Eine Einführung mit Übungen. Gebrüder Bornträger Berlin, Stuttgart.
- Krebs, D. 1984. Geologie der zweiten Jurakette östlich der Klus von Gänsbrunnen. Unveröff. Diplomarbeit Univ. Basel.
- Laubscher, H. & L. Hauber. 1982: Querschnitt durch das Juragebirge zwischen Oensingen und Balsthal (Exkursion F am 17. April 1982). *Jber. Mitt. oberrh. geol. Ver. N.F.* 64, 73-77.
- Laubscher, H. & U. Pfirter. 1984: Bericht über die Exkursion der Schweizerischen Geologischen Gesellschaft in den östlichen Faltenjura, vom 15. bis 17. Oktober 1983. *Ecloga geol. Helv.* 77/1, 205-219.
- Lüscher, P. 1975. Beiträge zur Hydrometeorologie und Hydrologie des Dünnerntals (Solothurnerjura) Dissertation Universität Bern, Zibo Druck Bottmingen, 1977.
- Meier, B. 1977. Zur Geologie der Klus von Balsthal-Oensingen (Ostseite). Unveröff. Diplomarbeit Univ. Basel.
- Meyer, J. 1977. Zur Geologie der Klus von Mülliswil. Unveröff. Diplomarbeit Univ. Basel.
- Regli, Ch. 1997. Grundwassermodell für die Klus von Oensingen-Balsthal, Kt. Solothurn. Diplomarbeit NDS der ETH-Zürich, unveröffentlicht.
- Tschumi, P. 1983. Geol. Untersuchungen in der Weissensteinkette westl. der Klus von Balsthal. Unveröff. Liz. Univ. Bern.
- Unmüssig, N. 1995. Grundwassermodell für das Dünnerntal(Herbertswil bis Klus Oensingen-Balsthal). Diplomarbeit NDS der ETH-Zürich, unveröffentlicht.
- Wiedenmayer, C. (1923): Geologie der Juraketten zwischen Balsthal und Wangen a.A. *Beitr. geol. Karte der Schweiz N. F.* 48.

Speleogenesis of phreatic channels in bedding-planes in the frame of karst aquifer (Škocjanske jam Caves, Slovenia)

by Martin Knez

Institute for Karst Research ZRC SAZU SI-6230 Postojna, Slovenia

Abstract

There have been much less researchers looking for the initial water ways in karst along the bedding-planes than those who deduced the origin of cave channels from tectonic structures.

It is hard to say whether bedding-planes or faults and joints are more important for initial guides for water in early stages of speleogenesis. The very detailed study had identified that the basic idea of bedding-plane importance at the initiation of cave channels was correct but also, that the interrelation is different as it had been supposed.

By my research I tried to light up the problem after the example of initial passages in Velika dolina collapse dolina in Škocjanske jame Caves.

Résumé

La genèse des conduits à partir de joints de stratification a été beaucoup moins étudiée que la genèse à partir de la structure tectonique.

Il est cependant difficile de dire si ce sont les joints de stratification ou les failles et fissures qui sont les plus importants pour la genèse des conduits initiaux pendant les premières phases de la spéléogénèse. L'étude très détaillée a montré que l'idée de l'importance du rôle des joints de stratification pour l'initiation des galeries est correcte mais les relations sont différentes de celles supposées.

L'article veuille éclairer ce problème en étudiant les galeries initiales dans Velika dolina (Škocjanske jame).

1. Introduction

Wider area of Škocjanske jame Caves belongs to the karst called Škocjanski Kras. To the southeast this part of the classical Karst is situated against the impermeable flysch rocks of the Brkini Hills from where flows the Reka river that had excavated the Škocjan Cave System, about 5 km in length. Velika Dolina is collapsed doline located close to the actual swallow-hole of the Reka river.

Why we have chosen just Velika Dolina collapse doline for detailed geological and speleogenetical studies that might bring the answer to the question why underground passages in phreatic zone developed in some bedding-planes only and why just in these bedding-planes and not elsewhere.

Until 1983 archaeological, historical, turistical and hydrographical descriptions and reports prevail in the publications related to Škocjanske jame Caves. Geological data related to the cave system and its vicinity were more or less based on geological maps and their commentaries. Various authors mostly assessed how active and fossil passages developed in the Quaternary.

The second reason lies in fact that in Škocjanske jame Caves bedding is well pronounced and bedding-planes seem to exercise a decisive influence on speleogenesis. Further comparison between the data obtained in the Velika Dolina collapse doline with entrance and inner parts of the cave is possible and also, these results may be included into studies of wider vicinity of the cave.

As a third reason I can without doubt confirm that Škocjanske jame Caves is one of the central objects in the Classical Karst developed in the rocks typical of this karst.

2. Problematics

The aim of my research was to focus the scientific attention on the sphere where the answers within the sedimentology might be expected. The study had identified that the basic idea of bedding-plane importance at the initiation of cave water channels was correct but also, that the interrelation is different as it had been supposed. Single lithological, petrological or stratigraphical parameters of the initial water channels are only partly known, or merely guessed. My researches threw light on the problem of initial phreatic channels met in Velika dolina in Škocjanske jame Caves. Cave passages, or their fragments and other traces of the underground karstification do not appear scattered at random on the walls but they are obviously gathered along small number of so called *formative bedding-planes*.

The choice of literature within the sphere of wider problematics is rather modest. There are only about five units dealing with bedding-planes as medium of initial channels: DAVIES (1960), EWERS (1966), RAUCH & WHITE (1970), FORD & EWERS (1978).

Other researchers, as for example DREYBRODT (1988), WHITE (1988), FORD & WILLIAMS (1989), PALMER (1991), WORTHINGTON (1991), LOWE (1992), ŠUŠTERŠIČ (1994) cite the mentioned authors, perform some previously expected conclusions and introduce new basic karstological starting-points.



Figure 1. Location of Škocjanske jame Caves.

The basic working method was to locate the phreatic channels or their fragments, to sample and microscope those parts of the layers adjacent to a bedding-plane. Somewhere a whole layer was considered. Other methods were: regional distribution of caves, photographing, inventarisation and classification of speleogens and complexometry, the latter providing the purity of limestones.

3. Discussion of the studied bedding-planes

By microscope analyses I did not assess either characteristic sedimentary sequences or remarkable differences within a rock. This is why I focused concern on other researches.

One of the main focuses was also researche of calcite veins.

Calcite veins are essentially more numerous in immediate vicinity of formative bedding-planes than in the area between them. Close below the formative bedding-planes there is essentially less of calcite veins than close above a formative bedding-plane.

Calcite veins are essentially thicker close to formative bedding-planes than farther.

Increased number and the location of calcite veins in microscopic preparations clearly indicate that along formative bedding-planes the interbedded slides occurred. I did not notice it macroscopically during the field work and it was later determined by thin sections only. As I sampled continuously it was clearly shown that the beds are damaged or crushed (in a distance from formative bedding-plane - above or below it) only within degree of order of some millimeters to some centimeters. It was impossible to absolutely determine the product of slide. We may assume that they are due to attrition among beds (KNEZ, 1996).

4. Results

Briefly, we may answer two basic questions:

1. In fact former channels are very concentrated along **only three** "formative" bedding-planes among 62 observed (means **less than 5%**) and this concordance cannot possibly be only apparent.
2. Formative bedding-planes differ from the others by the following properties at least:
 - a. the rock along these bedding-planes is typically damaged, indicating interbedded wrench-fault;
 - b. the calcite level is slightly (0,33%) however typically, higher than farther on;
 - c. the rock along them is less porous than farther on;
 - d. formative bedding-planes are dividing-lines among sedimentary cycles.



Figure 2. Well seen bedding-planes.

5. Conclusions

The original former water channels are practically **gathered along only three formative bedding-planes - out of 62 measured (4,8% only)**; their close vicinity differs from the others in several important properties: typically damaged rock, higher level of calcium carbonate, smaller porosity and others. Consequently the mentioned concordance cannot possibly be only apparent.

From the lithological point of view I did not get neither substantial argument nor explanation for selective karstification. However it was identified that, at least in respect of a concrete example from Velika dolina, **the inception started along interbedded slides that without doubt pushed the beds aside leaving an interval.**

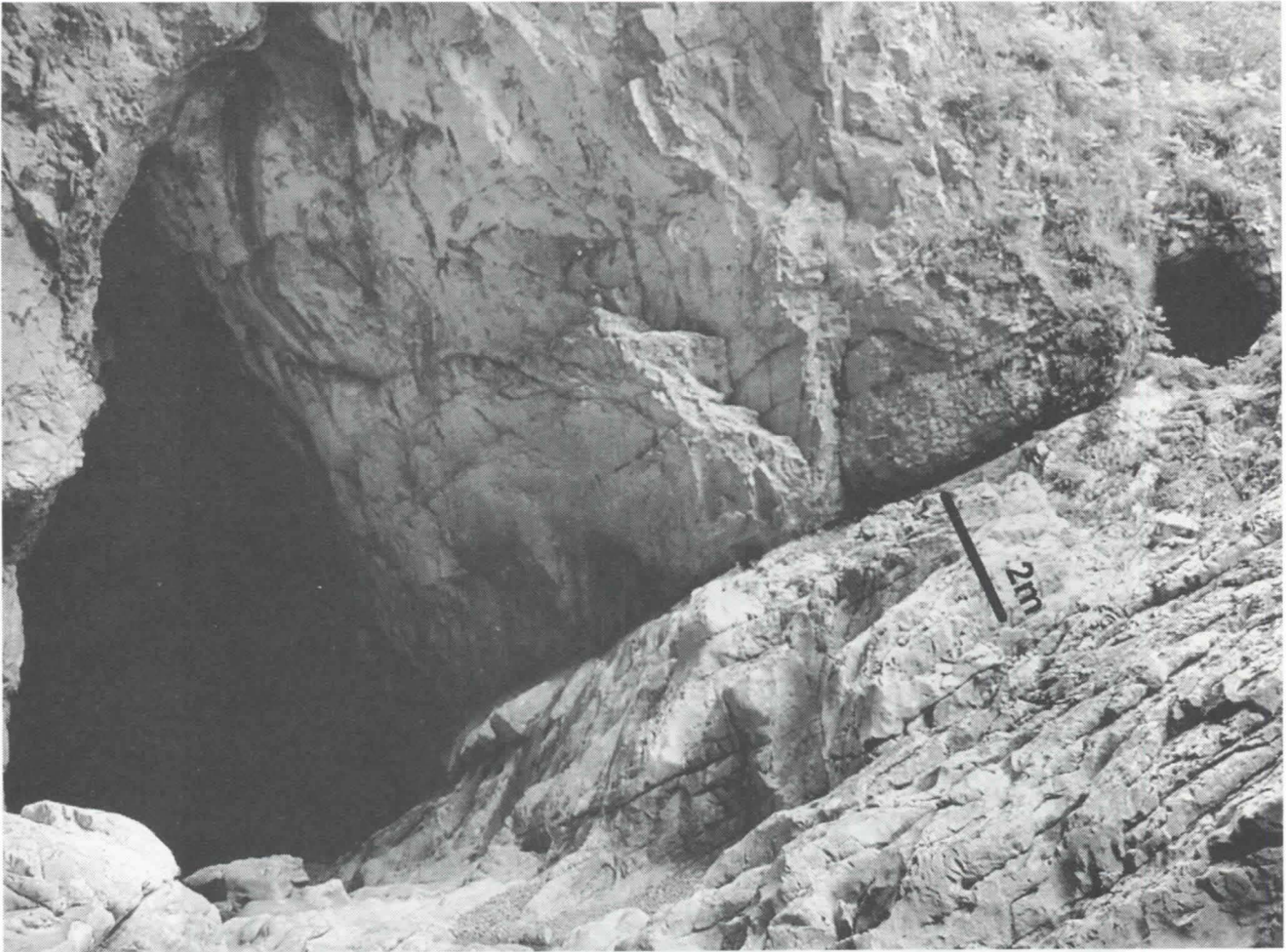

Figure 3. One of formative bedding-planes and swallow-hole of Reka river.

References

- DAVIES, W. E. 1960. Origin of Caves in Folded Limestone. *Bulletin of National Speleological Society*, 22, 1, 5-22, Alexandria, Virg.
- DREYBRODT, W. 1988. *Processes in Karst Systems. Physics, Chemistry, and Geology*. Springer-Verlag, XII+288 p., Berlin, Heidelberg.
- EWERS, R. O. 1966. Bedding-plane Anastomoses and Their Relation to Cavern Passages. *Bull. Nat. Spel. Soc.*, 28, 3, 133-140, Arlington.
- FORD, D. C. & EWERS, R. O. 1978. The development of limestone cave systems in the dimensions of length and depth. *Canadian Journal of Earth Sciences*, 15, 11, 1783-1798.
- FORD, T. D. & WILLIAMS, P. 1989. *Karst Geomorphology and Hydrology*. XV + 601 p., Unwin Hyman, London.
- KNEZ, M. 1996. Vpliv lezik na razvoj kraških jam. (Primer Velike doline, Škocjanske jame). *Znanstvenoraziskovalni center SAZU*, 14, 186 str., Ljubljana.
- LOWE, D. J. 1992. The origin of limestone caverns: an inception horizon hypothesis. Unpublished PhD thesis, XIX+512 str., Manchester Polytechnic, Manchester.
- PALMER, A. N. 1991. Origin and morphology of limestone caves. *Geological Society of American Bulletin*, 103, 1-21.
- RAUCH, H. W. & WHITE, W. B. 1970. Lithologic Controls on the Development of Solution Porosity in Carbonate Aquifers. *Water Resources Research*, 6, 4, 1175-1192, Pennsylvania State University, Pennsylvania.
- ŠUŠTERŠIČ, F. 1994. Jama Kloka in začetje. *Naše jame*, 36, 9-30, Ljubljana.
- WHITE, W. B. 1988. *Geomorphology and hidrology of karst terrains*. Oxford University Press, 464 p, New York.
- WORTHINGTON, S. R. H. 1991. *Karst hydrogeology of Canadian Rocky Mountains*. Unpublished PhD thesis, XVII + 227 str., McMaster University Hamilton, Hamilton.

Caractérisation du karst de La Rochefoucauld (Charente, France) à l'aide des analyses corrélatoire et spectrale

Marie Larocque¹, Alain Mangin², Moumtaz Razack¹ et Olivier Banton³

¹Laboratoire d'Hydrogéologie, URA CNRS 721, Université de Poitiers, 40 ave. Recteur Pineau, 86022 Poitiers Cedex, France, e-mail : larocque@hydrogeo.univ-poitiers.fr

²Laboratoire souterrain du CNRS, Moulis 09200, St-Girons, France

³ INRS-Eau, Université du Québec, 2800 rue Einstein, C.P. 7500, Ste-Foy, Québec, G1V 4C7, Canada

Abstract

The objective of this work was to demonstrate that correlation and spectral analysis can be used with various types of time-series data to provide valuable spatio-temporal information on the hydrodynamic characteristics and flow conditions in the La Rochefoucauld karst (Charente, France). Results show that the aquifer has an important inertia and large storage capacities. It is recharged by precipitation and by three of the four rivers flowing on its domain. The aquifer presents a large spatial heterogeneity and most rapid flow appears to occur in the northern part of the aquifer. Hourly piezometric and electrical conductivity chronicles indicate that there is an important temporal heterogeneity as some conductive channels become desaturated during the low waters. The observation of earth tides and barometric effects were used to identify the total porosity and specific capacity of the aquifer.

Résumé

L'objectif de ce travail était de montrer que les analyses corrélatoire et spectrale peuvent être utilisées avec différents types de chroniques pour fournir une information spatio-temporelle sur les conditions hydrodynamiques dans l'aquifère du karst de La Rochefoucauld (Charente, France). Les résultats montrent que l'aquifère a une inertie importante et de grandes capacités d'emmagasinement. La recharge provient des précipitations ainsi que de trois des quatre rivières coulant sur le domaine. L'aquifère présente une grande hétérogénéité spatiale, la partie Nord étant la plus karstifiée. Les chroniques piézométriques et de conductivités électriques mettent en évidence une variabilité temporelle des écoulements. L'observation des effets de la marée terrestre et de la pression atmosphérique ont permis le calcul de la porosité totale et de l'emmagasinement spécifique de l'aquifère.

1. Introduction

Il n'est pas facile de modéliser les écoulements dans un aquifère karstique principalement à cause de la très grande hétérogénéité du milieu qui en rend difficile la description. Différentes méthodes doivent donc être mises en œuvre pour caractériser le mieux possible le milieu à modéliser. Les méthodes classiques (essais de pompage, traçages) et l'approche systémique sont nécessaires à la description du milieu, mais les informations ainsi obtenues sont souvent incomplètes. Les analyses corrélatoire et spectrale sont un outil complémentaire dans la connaissance d'un milieu karstique.

Les analyses corrélatoire et spectrale ont été utilisées (MANGIN, 1984 ; MORALES-JUBERIAS, 1996) pour relier les débits aux précipitations dans différents aquifères karstiques. D'autres types de séries temporelles peuvent aussi être analysées pour acquérir plus d'information sur le milieu étudié. L'objectif de ce travail est de montrer que les analyses corrélatoire et spectrale peuvent être utilisées avec différents types de chroniques pour caractériser les conditions hydrodynamiques et approfondir la connaissance de l'aquifère du karst de La Rochefoucauld (Charente, France). Un grand nombre de chroniques sont disponibles sur cet aquifère : débits à la résurgence, débits dans les rivières, niveaux piézométriques, conductivité électrique de l'eau en rivière et à la résurgence, pression atmosphérique et précipitations. Les résultats sont interprétés comme des informations additionnelles pour le choix de la meilleure approche de modélisation et pour la paramétrisation du modèle.

La théorie des analyses corrélatoire et spectrale utilisée dans ce travail provient des travaux de MAX (1980), de MANGIN (1984) et de BOX *et al.* (1994).

2. Le karst de La Rochefoucauld

Le karst de La Rochefoucauld (Figure 1) s'étend sur une superficie d'environ 600 km². Il est localisé dans les calcaires du Jurassique moyen et supérieur qui se développent à l'Est de la ville d'Angoulême (Charente, France). L'aquifère prend naissance à l'Est au contact du Massif central et se développe vers l'Ouest jusqu'à la faille de l'Echelle qui bloque l'écoulement. Ces calcaires ont été soumis à la karstification sur plus d'une centaine de mètres. Des variations importantes de niveaux piézométriques et de débits à la résurgence principale sont des manifestations de la présence d'écoulements rapides. D'autre part, des essais de pompage ont montré que l'aquifère se comporte localement comme un milieu fracturé. L'aquifère, qui est en nappe libre, repose sur les formations imperméables de l'Aalénien et du Toarcien.

Quatre rivières coulent sur l'aquifère. Le Bandiat et la Tardoire prennent leur source sur le Massif central et ne sont pas pérennes. La Bonnière coule toute l'année dans la partie Nord de l'aquifère. L'Echelle coule non loin de la faille du même nom sur la limite Ouest de l'aquifère. Les pertes du Bandiat et de la Tardoire sont une composante importante des débits du Bouillant et de la Lèche (51% selon un bilan hydrique annuel). Les lignes d'écoulement déduites de données piézométriques montrent qu'en basses eaux, une partie de la Bonnière contribue aux résurgences alors qu'en hautes eaux, la Bonnière draine la partie Nord de l'aquifère. Des traçages (QUELENNEC *et al.*, 1971) réalisés à différents endroits sur le Bandiat et la Tardoire ont montré l'existence d'un lien direct et rapide (vitesses entre 44 et 98 m/h selon la période de l'année) entre ces rivières et les résurgences.

La résurgence pérenne du Bouillant est localisée sur la limite Ouest non loin de la faille qui bloque l'aquifère. La résurgence secondaire de la Lèche est située environ 500 m en amont. Les

deux résurgences se combinent avec l'Echelle pour former la Touvre (débit moyen de 12.8 m³/s). Les contributions de la Lèche et de l'Echelle sont faibles (débit moyen combiné de 0.9 m³/s).

Les débits de la Touvre sont mesurés à la station de Foulpougne en aval des résurgences et représentent essentiellement les débits du Bouillant (étant donnés les faibles débits de l'Echelle et de la Lèche). Les débits de la Lèche sont mesurés individuellement. Les débits en rivières sont mesurés sur l'Echelle (Chez Drau), sur le Bandiat (à Feuillade en amont des pertes principales), sur la Tardoire (à Montbron en amont des pertes principales et à Coulgens en aval des pertes principales) et sur la Bonnieure (à Villebette). Huit piézomètres mesurant les niveaux d'eau dans le karst sont distribués sur l'aquifère : à Agris, au Bouillant (dans le conduit principal de la résurgence), à Bouëx, à Chazelles, à la Fosse Mobile, à La Rochefoucauld, à Mornac et à St-Amant. Des chroniques de conductivités électriques horaires ont été relevées dans le Bandiat (à Feuillade), dans la Tardoire (à Montbron) et dans le Bouillant pendant l'année 1992 (SQUARCIONI, 1993).

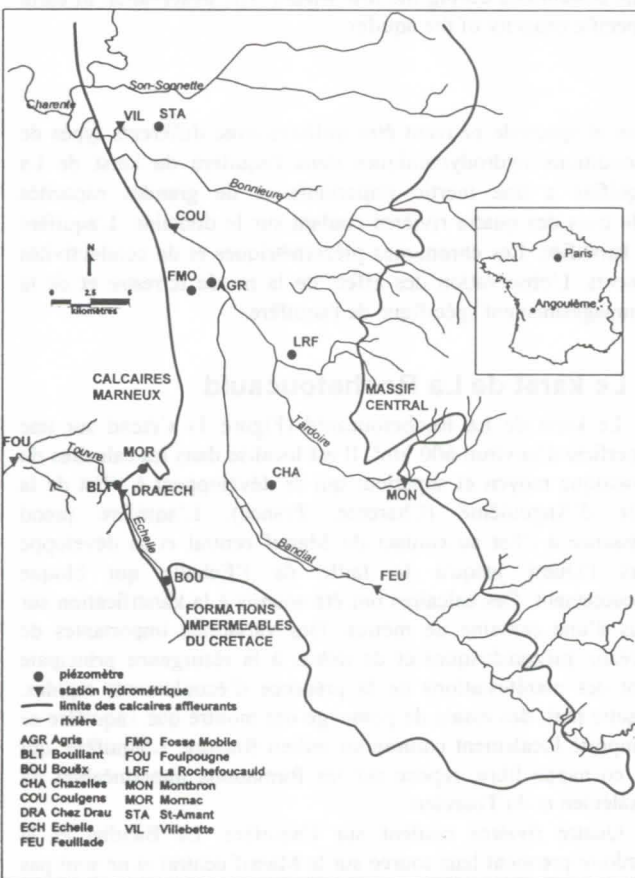

Figure 1 : Le karst de La Rochefoucauld (Charente, France)

3. Résultats

Chroniques de débits

Une analyse à court terme (une année) des chroniques de débits aux résurgences et en rivières a été réalisée. Les corrélogrammes de ces chroniques (Figure 2) diminuent très lentement, ce qui est une indication que l'aquifère possède des réserves importantes qui se vidangent sur une longue période. Le temps de régulation, qui définit la durée d'influence du signal d'entrée et qui peut aussi être assimilé à la longueur de la réponse impulsionnelle du système, est de 76.4 et 72.9 jours pour les chroniques de Foulpougne et de la Lèche respectivement. Une analyse à long terme (sept ans) de ces mêmes chroniques a

permis de mettre en évidence une importante composante annuelle de l'écoulement. Cette composante est un autre indice des réserves importantes de l'aquifère qui régularise les cycles annuels de la recharge.

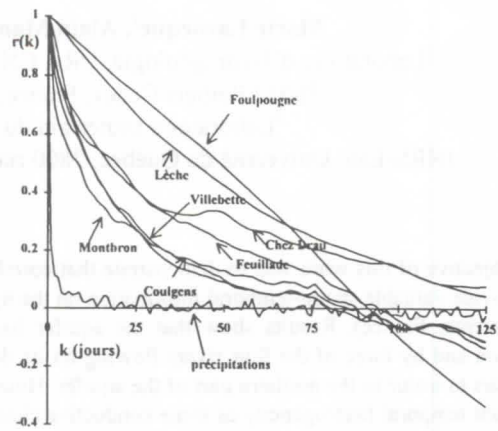

Figure 2 : Corrélogrammes des chroniques de débits

Les résultats de l'analyse corrélatrice croisée, avec la chronique des précipitations comme fonction d'entrée et les chroniques de débits aux résurgences comme fonctions de sortie, sont illustrés à la Figure 3. Le maximum de corrélation est atteint six et huit jours après un événement pluvieux pour Foulpougne et la Lèche respectivement, délai représentant le temps de transfert de l'onde de pression à travers l'aquifère. Les corrélations maximales faibles indiquent que l'aquifère amorti substantiellement la fonction d'entrée. La décroissance lente des corrélogrammes croisés indique à nouveau une grande inertie de l'aquifère et des réserves importantes. La fonction de cohérence, qui exprime l'intensité et la linéarité du lien entrée-sortie, est de 0.68 pour Foulpougne et de 0.48 pour la Lèche, ce qui indique que la partie de l'aquifère drainée par le Bouillant se comporte de manière linéaire par rapport aux précipitations alors que le secteur drainé vers la Lèche transforme le signal plus comme un milieu fracturé. Ces observations confirment les résultats de Blavoux *et al.* (1988) selon lesquels la partie Sud de l'aquifère (milieu essentiellement fracturé, peu de karstification) serait drainée principalement vers la Lèche alors que la partie Nord serait drainée vers le Bouillant (milieu plus karstifié).

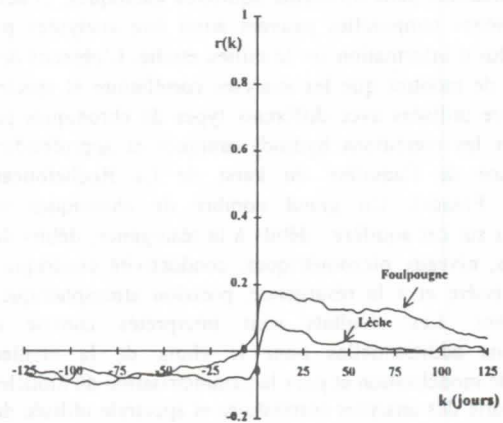

Figure 3 : Corrélogrammes croisés des chroniques de débits

Une analyse corrélatoire croisée, avec les chroniques de débits en rivières comme fonction d'entrée et les chroniques de débits aux résurgences comme fonctions de sortie, a aussi été réalisée. Cette analyse confirme la présence d'un lien rivières/résurgences pour toutes les rivières sauf l'Echelle qui ne participe donc pas à la recharge de l'aquifère. Les relations rivières/Foulpouagne sont plus linéaires (corrélations maximales de 0.70 à 0.78) que les relations rivières/Lèche (corrélations maximales de 0.51 à 0.53).

Chroniques piézométriques

Les chroniques piézométriques représentent l'état du système à différents endroits et comportent des renseignements importants sur la variabilité spatiale de l'hydrodynamique de l'aquifère.

Les corrélogrammes croisés, avec la chronique des précipitations journalières comme fonction d'entrée et les chroniques piézométriques journalières comme fonctions de sorties, sont similaires pour les stations d'Agris, de Mornac, de St-Amant et de la Fosse Mobile avec des maximums de corrélation entre 0.12 et 0.15 et un délai variant entre 10 et 15 jours. Les corrélations maximales sont plus retardées pour les stations de La Rochefoucauld et Chazelles (59 et 61 jours respectivement). Ces délais plus longs indiquent sans doute le passage à travers un milieu moins karstifié. La fonction cohérence est faible pour les piézomètres de Chazelles et de Bouëx (secteur Sud) et est maximale pour Agris et la Fosse Mobile (secteur Nord), ce qui confirme à nouveau les résultats de Blavoux *et al.* (1988).

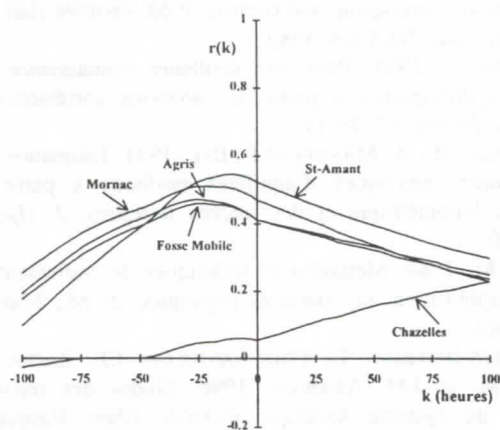

Figure 4 : Corrélogrammes croisés des chroniques piézométriques horaires

Les chroniques piézométrique horaires ont été analysées pendant deux périodes distinctes (hautes et basses eaux) afin de mettre en évidence une éventuelle variabilité temporelle des écoulements. Une analyse corrélatoire croisée a été réalisée avec les chroniques piézométriques horaires réparties sur l'aquifère comme fonction d'entrée, et la chronique piézométrique horaire du Bouillant comme fonction de sortie. Pendant la période de hautes eaux (Figure 4), quatre des cinq stations analysées (le piézomètre de Chazelles faisant exception) présentent un corrélogramme inversé avec des maximums de corrélations pour les temps négatifs (délais de -11 à -23 heures). Cette inversion indique que le niveau d'eau au Bouillant réagit aux impulsions avant les niveaux des autres piézomètres. Une partie de l'impulsion se déplace rapidement à travers l'aquifère sans doute à la faveur de fractures karstifiées très conductrices, et atteint le Bouillant avant d'atteindre les piézomètres. L'apparence très différente du corrélogramme croisé pour la station de Chazelles

peut s'expliquer par le fait que ce piézomètre est localisé dans la partie Sud de l'aquifère (moins karstifiée). Pendant la période de basses eaux, on n'observe pas cette inversion. Ceci laisse supposer que la baisse des niveaux d'eau en période sèche désature certaines fractures fortement conductrices. L'aquifère serait donc moins transmissif en basses eaux qu'en hautes eaux.

Une analyse corrélatoire croisée avec les chroniques de pression atmosphérique horaires comme fonctions d'entrée et les chroniques piézométriques horaires comme fonctions de sortie, a permis de retrouver l'influence de la pression sur les niveaux piézométriques. L'effet de la marée terrestre a aussi été observé sur certaines chroniques piézométriques. Le traitement mathématique des chroniques a été réalisé selon la méthode de Marsaud *et al.* (1993) et a permis de déduire la porosité totale et l'emménagement spécifique de l'aquifère en différents endroits. Les valeurs obtenues pour la porosité totale varient de 1 à 2% et celles de l'emménagement spécifique varient de 10^{-6} à 10^{-7} . L'observation de ces effets à très court terme (12 et 24 heures) indique que l'aquifère se comporte comme une nappe captive (ces effets étant négligeables en nappe libre). Ce comportement peut s'expliquer par la présence d'une grande hétérogénéité verticale du milieu. Localement, il peut exister une couche conductrice transportant d'importants volumes d'eau et se comportant de manière captive par rapport aux calcaires moins karstifiés avoisinants.

Conductivités électriques

Les chroniques de conductivités électriques de l'eau renseignent sur le déplacement de l'eau dans le système. Ces chroniques (horaires) sont analysées pendant deux périodes distinctes (hautes et basses eaux) afin de mettre en évidence des variations temporelles dans le mode de transfert des particules.

Une analyse corrélatoire croisée a été réalisée avec les conductivités électriques en rivières comme fonctions d'entrée, et les conductivités électriques au Bouillant comme fonction de sortie (Figure 5). Pendant la période de recharge, les corrélogrammes croisés montrent que les réactions des rivières et de la résurgence sont opposées : lorsque les conductivités électriques diminuent en rivières, elles augmentent à la résurgence. Ceci peut être interprété comme un effet de chasse. Lorsque les débits augmentent en rivière (après un événement pluvieux), les conductivités y diminuent par dilution. Simultanément, il y a augmentation de l'apport d'eau dans l'aquifère, principalement via les pertes en rivières, mais aussi par la recharge diffuse. Cette eau additionnelle crée un front de pression qui chasse l'eau en place minéralisée par la roche, celle-ci est mobilisée rapidement vers la résurgence probablement par l'intermédiaire de fractures karstifiées très conductrices. Cette eau fortement chargée en minéraux atteint rapidement la résurgence, y créant ainsi un pic de conductivité électrique. Lorsque toute l'eau minéralisée a été remplacée, les conductivités à la résurgence diminuent à nouveau et le corrélogramme croisé devient positif après 138 et 163 heures pour la Tardoire et le Bandiat respectivement. Ces temps de transfert sont similaires à ceux observés lors des traçages (QUELENNEC *et al.*, 1971). Le comportement de l'aquifère est différent pendant la période de basses eaux. A ce moment, la réaction rivières/résurgence est directe : lorsque les conductivités diminuent dans les rivières, elles diminuent aussi à la résurgence, après 295 et 355 heures pour la Tardoire et le Bandiat respectivement. Ce comportement peut s'expliquer par le fait qu'en basses eaux certains drains sont désaturés, le transfert rapide est beaucoup moins important et l'eau minéralisée rejoint la résurgence lentement à travers des fractures peu ouvertes.

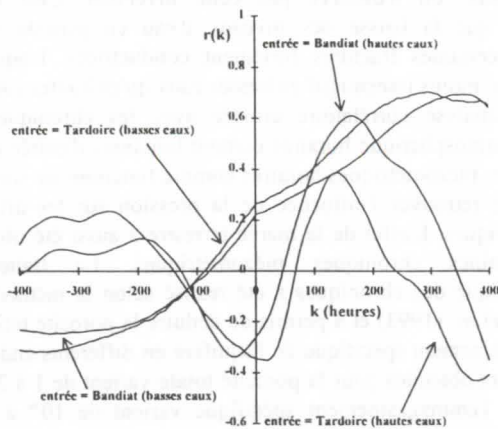

Figure 5 : Corrélogrammes croisés des chroniques de conductivités électriques

4. Discussion et conclusion

Malgré la variabilité spatiale de ses caractéristiques hydrodynamiques, le karst de La Rochefoucauld présente une grande inertie et des réserves importantes. De plus, les observations sur le terrain ont montré que de manière générale les gradients hydrauliques sont plutôt faibles. Une modélisation en milieu continu équivalent de cet aquifère pourrait donc procurer une première approximation réaliste des écoulements à l'échelle régionale. Toutefois, même si les écoulements sont globalement laminaires, il est possible que les écoulements dans les fractures karstifiées les plus ouvertes soient turbulents. Dans ce cas, une modélisation en milieu continu équivalent (basée sur la loi de Darcy) ne permettrait pas de décrire les écoulements dans les conduits karstiques.

D'autres renseignements importants pour la connaissance et la modélisation de cet aquifère ont pu être déduits des analyses corrélatrice et spectrale. Ainsi, la nature de la recharge de l'aquifère ainsi que ses limites ont été précisées. L'analyse a montré qu'il existe une relation entre les précipitations et les résurgences d'une part et entre trois des quatre rivières et les résurgences d'autre part. L'analyse corrélatrice croisée a montré que ces rivières influencent à la fois le Bouillant et la Lèche. Ces résultats confirment que la Bonnière fait partie du bassin hydrogéologique, au moins pendant une partie de l'année. Le lien entre l'Echelle et les résurgences semble toutefois presque inexistant. Pour cette raison, on pourrait exclure ce cours d'eau de la modélisation. La variabilité spatiale des caractéristiques hydrodynamiques du milieu a aussi été démontrée par les analyses croisées rivières/résurgences et par les différentes réponses des niveaux piézométriques aux signaux d'entrée. Cette information confirme que la partie Sud de l'aquifère transfère les signaux plus lentement et de manière plus atténuée que la partie Nord. Le secteur le plus karstifié semble être situé dans les environs des piézomètres d'Agris et de la Fosse Mobile. L'observation des effets de la marée terrestre et de la pression atmosphérique met en évidence l'importante variabilité verticale du milieu. Deux périodes d'écoulement émergent aussi de l'analyse comme ayant des caractéristiques distinctes : les hautes eaux pendant lesquelles des fractures très conductrices sont saturées et les basses eaux pendant lesquelles le milieu saturé est moins transmissif.

L'utilisation des analyses corrélatrice et spectrale avec différents types de séries temporelles distribuées spatialement sur l'aquifère a fourni des renseignements très utiles concernant les caractéristiques hydrodynamiques et les conditions d'écoulement sur le karst de La Rochefoucauld. Les résultats confirment la grande variabilité spatiale des écoulements et précisent la localisation de certains secteurs plus conducteurs. D'autre part, les résultats ont mis en évidence les réserves importantes de cette aquifère, un aspect de l'écoulement souvent négligé devant des manifestations karstiques parfois impressionnantes (pertes en rivières, résurgences).

La collecte et l'analyse des séries temporelles de types variés et distribuées spatialement est une opération importante et relativement peu coûteuse qui devrait faire partie de toute campagne de caractérisation d'un aquifère karstique. Lorsqu'elles sont étudiées avec les analyses corrélatrice et spectrale, ces chroniques fournissent des renseignements pertinents sur la structure et le comportement du milieu. Les analyses corrélatrice et spectrale sont donc un important outil d'investigation du milieu karstique qui complète bien les techniques classiques.

Références

- BLAVOUX, B., J. MUDRY et D. ROULLER. 1988. Identification des eaux d'infiltration diffuse et concentrée dans l'écoulement d'une source karstique : exemple de la Touvre et de la Lèche (Angoulême - Charente). Ann. Scien. Univ. Besançon. Géol. Mémoire hors série no 6. Quatrième Colloque d'hydrologie en pays calcaire. Besançon, Suisse. 29/9-1/10 1988. pp. 83-90.
- BOX, G.E.P., G.M. JENKINS and G.C. REINSEL. 1994. Time series analysis : forecasting and control. 3^e éd. Prentice Hall Inc. Englewood Cliffs, NJ, USA. 598p.
- MANGIN, A. 1984. Pour une meilleure connaissance des systèmes hydrologiques à partir des analyses corrélatrice et spectrale. *J. Hydrol.* 67 :25-43.
- MARSAUD, B., A. MANGIN et F. BEL. 1993. Estimation des caractéristiques physiques d'aquifères profonds à partir de l'incidence barométrique et des marées terrestres. *J. Hydrol.* 144:85-100.
- MAX, M. 1980. Méthodes et techniques de traitement du signal et application aux mesures physiques. 2^e éd., Masson. Paris, France.
- MORALES-JUBERIAS, T., CRUZ-SANJULIAN J.J., ZAFRA, P., OLAZAR, M. et J.M. ARANDES. 1996. Etudes des réponses naturelles du système karstique d'Olalde (Pays Basque) : approche de la reconnaissance de sa structure interne. *Hydrogéologie* 1:39-51.
- QUELENNEC, R.E., J.C. SAURET, M. SEGUIN et J. VOUVE. 1971. Les résurgences de la Touvre. Etude préliminaire. Ann. Sci. Univ. Besançon. Géol. 3^e série. Fasc. 15. Colloque d'hydrologie en pays calcaire. Besançon, Suisse. 8/10-9/10 1971. pp. 197-255.
- SQUARCIONI, P. 1993. Etude du transit de l'eau dans le réservoir karstique de la Touvre au moyen des courbes de flux chimique débit. Hydro-Invest rapport no 93010090. Etude réalisée pour le Conseil Général de la Charente.

Hydrologie karstique en région de pergélisol : l'exemple du Yukon septentrional, Canada

par Bernard Lauriol *, Ian D. Clarck * & Jacques Cinq-Mars **

* Centre géoscientifique Ottawa-Carleton, Université d'Ottawa Ottawa, Ontario, K1N 6N5, Canada

** Commission archéologique du Canada, Musée Canadien des Civilisations, 100, rue Laurier, Hull, Québec, Canada

Abstract

The karst hydrology of the northern Yukon is influenced by the topography, the occurrence of permafrost, and geomorphological characteristics remnant from the Tertiary. The hydrology of the high plateaux and catchment regions is distinct from that of the low plateaux and valley bottoms. Groundwater circulation occurs both in the active zone and through talik zones within the thick permafrost of this region. Circulation through talik is strongly related to accumulations of snow and/or ponded water at the surface, which maintain or expand thawed ground. The principal points of recharge to the limestone terrain are associated with karst features produced during Tertiary, when permafrost did not exist in the region.

Résumé

L'hydrologie karstique au Yukon septentrional est influencée par la topographie, le pergélisol et l'héritage géomorphologique du Tertiaire. Il est possible en effet de distinguer l'hydrologie des hauts plateaux de celle des bas plateaux et l'hydrologie des versants de celle des fonds de vallée. Par ailleurs il existe une circulation d'eau dans la couche active et une autre dans la masse du pergélisol, suivant des taliks dont l'origine est associée à d'importantes accumulations de neige ou à des nappes d'eau. Finalement les principaux points de pénétration des eaux dans les massifs calcaires sont souvent liés à des formes mises en place quand le pergélisol n'existait pas dans la région, c'est-à-dire, au Tertiaire.

1. Introduction

L'hydrologie des karsts canadiens est dans l'ensemble très affectée par l'effet des glaciations quaternaires et en plus, dans les régions arctiques, par le pergélisol (FORD, 1987). Mais au Yukon septentrional la karstification a suivi une dynamique différente car en dépit de sa haute latitude (Figure 1) les glaciers ont été absents ou bien d'une dimension très restreinte. On se trouve donc en présence d'un karst qui a surtout été développé pendant le Tertiaire et qui a été partiellement détruit par l'incision fluviale au Quaternaire. Mais grâce à la karstification tertiaire et à un pergélisol pas trop froid, les eaux souterraines peuvent continuer à circuler. Cet article décrit la distribution des écoulements tels qu'ils nous sont apparus lors de divers séjours dans cette région. On présente les résultats en se déplaçant des sommets jusqu'au fond des vallées, soit de la toundra à la forêt boréale. Le climat de cette région est très froid en hiver (moyenne du mois de janvier: -27°C) et assez chaud en été (moyenne du mois de juillet: $+13^{\circ}\text{C}$). Ces conditions thermiques ont engendré un pergélisol continu dont l'épaisseur est indéterminée.

2. L'infiltration sur les hauts plateaux

Les sommets des massifs calcaires au Yukon septentrional culminent vers 1000 m d'altitude. Dans l'ensemble ils forment des arêtes très étroites séparant des ravins. Cependant, aux environs des massifs de Bear Cave et de Tsi-it-toh-Choh, il existe quelques plateaux développés dans les formations dévoniennes Gossage-Ogilvie (NORRIS, 1980). Sur ces plateaux se trouvent des dolines d'effondrement qui sont habituellement remplies de neige et

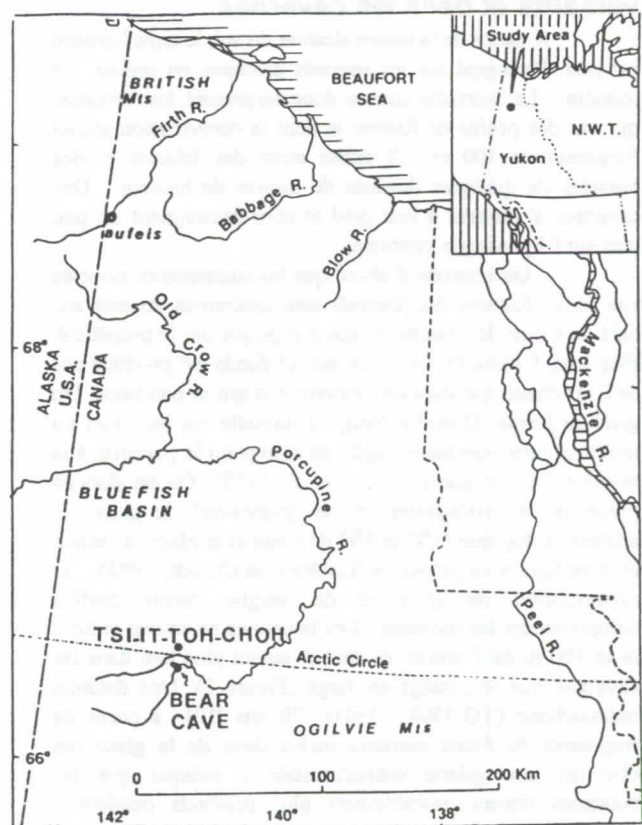

Figure 1. Carte de localisation de la région étudiée et des principaux noms de lieux.

occasionnellement inondées. L'origine de l'eau n'a pas été déterminée mais on suppose que lors de la fonte printanière des neiges il peut arriver qu'un bouchon de glace bloque le drainage. L'eau s'accumule jusqu'à ce que la glace disparaisse. Cependant habituellement un talik existe sous les dolines: il permet à l'eau de fonte de s'acheminer dans la masse calcaire.

Entre les dolines, le pergélisol réduit les possibilités d'infiltration: on a noté que lors de très fortes pluies le sol devient saturé en eau. De petits ruisseaux chargés de limon alimentent les ravins qui dissèquent les plateaux. L'infiltration n'a qu'un caractère accidentel: dans un cas l'eau ruisselle directement dans une caverne; elle y rencontre un barrage de glace lequel cède occasionnellement ce qui permet à l'eau de continuer son cheminement à l'intérieur du massif calcaire. Quand la vidange du lac est terminée, une nouvelle glace referme le passage. On a aussi observé dans un puits de 27 m de profondeur, obstrué en partie par de la neige pérenne, une arrivée d'eau à -5 m de l'entrée. Cette eau disparaissait à la base du puits, à travers des blocs, ce qui laisse supposer l'existence d'un talik. Enfin au pied d'un talus rocheux haut de 4 m et formant l'escarpement amont d'une terrasse de cryoplanation, on a pu voir une source de quelques litres/seconde. Elle s'écoulait sur une courte distance avant de s'infiltrer à nouveau dans le sol.

3. Le ruissellement des eaux sur les versants et dans les cavernes

A cause de la nature alcaline du sol, le tapis herbacé est peu développé sur les versants calcaires en milieu de toundra. La pierraille couvre donc largement les versants, qui ont des profils de Richter et dont la dénivellation atteint fréquemment 500 m. Il existe aussi des falaises et des pinacles de quelques dizaines de mètres de hauteur. Des cavernes s'ouvrent à leur pied et elles renseignent un peu plus sur l'hydrologie karstique.

On constate d'abord que les suintements associés aux micro-fissures des plafonds sont totalement absents au-delà de 4-5 m de l'entrée, ce qui s'explique par le pergélisol. Plus loin, l'humidité observée aux plafonds est produite par de l'air chaud qui vient de l'extérieur et qui se condense. Du givre se forme. Quand il fond, il ruisselle sur les murs ou tombe goutte-à-goutte et regèle en atteignant le parterre, à la manière d'un verglas (LAURIOL *et al.*, 1988). On est alors en présence de "stalagmites" et de "planchers" de glace. L'analyse isotopique $\delta^{18}\text{O}$ et $\delta^2\text{H}$ de l'eau et la glace a permis de bien figurer ce processus (LAURIOL et CLARK, 1993). L'accumulation de givre et de verglas ferme parfois complètement les passages. Les bouchons se situent entre 2 m et 100 m de l'entrée: ils sont d'autant plus loin dans les cavernes que le passage est large (Figure 2). Une datation radiocarbone (TO-3508: 7350 +/- 70 ans BP) à partir de fragments de *Picea mariana* inclus dans de la glace qui obstruait une galerie subhorizontale a indiqué que les bouchons étaient probablement plus profonds pendant l'hypothermal holocène (LAURIOL *et al.*, 1994). D'autres datations faites à partir de *Dryas octopetala* et *Cassiope tetragona* suggèrent au contraire que la glace était probablement plus épaisse entre 1300 et 800 ans BP.

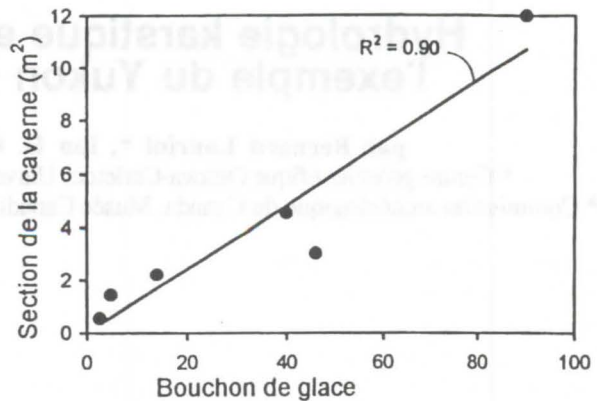

Figure 2: Relation entre la distance (en m) des bouchons de glace dans les cavernes à partir de l'entrée et la dimension des passages.

L'absence ou la rareté du silt sur les versants favorise grandement l'infiltration rapide de l'eau dans la pierraille lors des pluies ou de la fonte des neiges. L'essentiel de l'eau s'écoule à l'interface de la roche et des cailloux ou dans la zone rocheuse dégelée. Il nous est arrivé d'entendre le bruit de l'eau circulant entre les pierres à quelques mètres de profondeur. Par ailleurs l'eau suinte du plafond jusqu'à 4-5 m de distance à partir de l'entrée des cavernes. Ces deux phénomènes ne se produisent qu'après des orages, ce qui indique que l'écoulement est rapide dans la zone de la couche active.

L'écoulement concentré est rare mais ne paraît pas complètement absent dans les cavernes qui s'ouvrent sur les versants. Il y présente un caractère très épisodique. Par exemple, dans Bear Cave, une des plus importantes cavernes de la région, on a noté en juillet 1996 que les couloirs inférieurs avaient été inondés: un film de glace suspendu à 1,5 m du sol, long d'une dizaine de mètres, large de 80 cm, épais de 2 à 3 cm contenait encore des morceaux de bois qui avaient flotté. La température est négative (-1 à -2°C) dans ces couloirs, même au mois de juillet. Quelle fut la cause de l'inondation est une question à laquelle nous n'avons pas pu répondre. Où est allée l'eau demeure aussi une énigme. Cependant une cascade de glace (10 m x 15 m x .5m) localisée sur une paroi dans une caverne située en dessous de Bear Cave et, issue d'une eau ayant jailli d'un étroit passage pourrait être associée à la vidange des couloirs. La "découverte" d'une inondation dans une caverne où nous en avions jamais soupçonné la possibilité nous a permis de comprendre la position de vestiges organiques qui pendant plusieurs années nous avait dérouter.

4. Le drainage sur les bas plateaux, en zone de forêt boréale

Entre 300 et 500 m d'altitude les plateaux sont couverts par la forêt boréale et par des terrains tourbeux et parfois par des lacs. Comme dans d'autres régions calcaires

du Canada, notamment dans les régions de la Nahanni, des monts Mackenzie et du Grand Lac de L' Ours (FORD et WILLIAMS, 1989; VAN EVERDINGEN, 1981) les tourbières et les lacs peuvent être drainés par des dolines ou bien par des pertes localisées dans le talweg de leur émissaire. Une des plus spectaculaires se situe au sud de la plaine de Bluefish, vers 330 m d' altitude. Elle se trouve à l' extrémité d' un petit vallon d' une centaine de mètres de long qui draine un lac de 2 km² suivant une pente contraire à celle du versant sur lequel il est établi. La présence de galets de grès bien roulés et d' ossements du Pléistocène suggère que la perte pourrait avoir été fonctionnelle quand le lac glaciaire Old Crow existait, c' est-à-dire entre 30 et 15 ka (HUGHES, 1971).

Dans la même région, au sud-ouest de la plaine de Bluefish, un lac se vidange chaque année au mois de mars. Il mesure 2,5 km² et une dizaine de mètres de profondeur. Il est plein d' eau en été, puis il se couvre de glace à l' automne. Vers le mois de mars il se draine à partir d' une dépression située en son centre et qui est semblable aux dolines locales. Il se remplit à nouveau, au mois de mai, à la fonte des neiges. De tels phénomènes ont été aussi décrits dans les régions citées ci-dessus (Nahanni, monts Mackenzie et Grand Lac de L' Ours). Ils sont sûrement en relation avec la formation de bouchons de glace qui s' édifient après la vidange, à la fin de l' hiver et qui mettent plusieurs mois à fondre.

Est-ce que des lacs sont eux-mêmes alimentés par des eaux souterraines? Certains étangs au pied de versants calcaires reçoivent en effet des eaux souterraines car ils ont des émissaires actifs mais pas d' affluents visibles. Des analyses hydrochimiques ont montré que leur eau a une dureté voisine de 100 mg/l ce qui est assez caractéristique des autres eaux souterraines dans la région (THIBAudeau *et al.*, 1988). Par ailleurs, selon les gens d' Old Crow, un lac au sud des monts British serait alimenté par une source jaillissant dans son fond ainsi que le suggère un bouillonnement.

5. Les résurgences dans les vallées

Les cours d' eau qui drainent les massifs calcaires du Yukon septentrional sont souvent à sec sur plusieurs kilomètres pendant les étés les plus chauds, avant d' être interrompus par une résurgence. Celle de la Fishing Branch, située au pied de Bear Cave, a un débit de quelques mètres cubes à la seconde. Elle fonctionne durant l' hiver et constitue un *Fishing Hole* c'est-à-dire un endroit propice à la pêche hivernale.

Les *Fishings Holes* sont cependant assez rares. Le plus souvent les résurgences donnent naissance à des aufeis (ou icing, naled, glaçage). Leur localisation est largement contrôlée par la géologie locale et leur fonte, par la radiation solaire (LAURIOL *et al.*, 1991). Le plus vaste est celui de la rivière Firth: il mesure 28 km de long, un à 2 km de large et 2,5 à 3 m d' épaisseur. Son volume estimé est de 80 à 95 x 10⁶ m³ de glace. C' est un des plus importants au Canada. Des calculs conduits à partir de données météorologiques, hydrologiques et géologiques ont montré que les eaux souterraines représentent 50% de l' alimentation dans le bassin (CLARK et LAURIOL, 1997). C' est un pourcentage proche de celui des terrains en zone libre de pergélisol où les

taux d' infiltration sont fréquemment de 50 à 80% (BONI et BONO, 1984). L' analyse $\delta^{13}\text{C}$ indique par ailleurs du méthane dans les eaux souterraines (environ 700 $\mu\text{g}\cdot\text{CH}_4\cdot\text{L}^{-1}$): elle serait due à la décomposition de la matière organique en conditions anaérobiques.

6. Conclusion: les dépôts de calcite associés à l' hydrologie karstique.

Les divers types d' écoulements notés au Yukon septentrional peuvent être groupés en fonction des dépôts de calcite qu' ils ont produits:

--d' abord, comme dans les Rocheuses et les monts Mackenzie (HARMON *et al.* 1977), les cavernes du Yukon septentrional renferment de nombreuses spéléothèmes. Les datations faites à l' université McMaster, sous la direction de Derek Ford, indiquent que pour l' essentiel les concrétions sont du Tertiaire, c' est-à-dire d' une époque où le pergélisol n' existait pas (LAURIOL *et al.*, 1997). A ce moment là les eaux circulaient dans les micro-fissures, dissolvaient et transportaient de la calcite. Le développement du pergélisol au début du Quaternaire, en scellant par de la glace les micro-fissures, a interrompu le processus. Lors d' interglaciaires assez longs et chauds, tel celui du stade isotopique 5, le pergélisol est devenu discontinu. Une circulation d' eau souterraine de faible ampleur est apparue. Elle a été accompagnée d' un concrétionnement près de l' entrée des cavernes plus particulièrement dans celles exposées au sud. --mais ce qui s' est surtout produit pendant les interglaciaires, c' est une précipitation de calcite dans la zone qui dégèle annuellement. Cette précipitation a donné naissance à des encroûtements sous la face inférieure des galets, semblables à ceux décrits entre autres, par SWEET (1974). Mais elle a formé aussi des encroûtements dans des fissures qui se sont élargies au fur et à mesure de l' épaissement de la croûte: la calcite provenant de la face opposée à celle sur laquelle la croûte s' est développée. Il s' agit d' un processus de croissance encore mal connu mais qui pourrait être associé à des bactéries: elles grugerait la roche et construiraient la croûte par leur déjection. Ces bactéries puiseraient leur énergie dans la matière organique apportée par les eaux souterraines. On n' a cependant pas encore pu observer les bactéries responsables du processus.

-- enfin le gel des eaux karstiques engendre des poudres de calcite cryogénique, c' est-à-dire des poudres issues du gel de l' eau riche en carbonates de calcium. Il s' agit d' un sédiment blanc ou gris, parfois un peu jaunâtre. Les analyses isotopiques $\delta^{13}\text{C}$ ont montré une grande différence entre la poudre produite par la formation des glaces souterraines et celle associée au gel des résurgences: dans les cavernes la formation de verglas se déroule en quelques secondes. Cela ne permet pas la réalisation des réactions d' équilibre dans la calcite formée. Il se produit alors un fractionnement cinétique qui conduit à un enrichissement en ^{13}C qui peut atteindre +17 ‰ (CLARK et LAURIOL, 1992). C' est une des valeurs les plus élevées observée en milieu ouvert, et plus particulièrement dans les sédiments karstiques.

Références

- BONI, C.F. et BONO, P., 1984. Essai de bilan hydrologique dans une région karstique de l'Italie centrale. In: (Burger and Dubertet, eds): Hydrology of karstic terrains, case histories. International Contributions of Hydrology, Vol. 1, Heise pp 27-31.
- CLARK, I. D. et LAURIOL, B., 1992. Kinetic enrichment of stable isotopes in cryogenic calcites. *Chemical Geology*, 102: 217-228.
- CLARK, I. D. et LAURIOL, B., 1997. (sous presse) Aufeis of the Firth River basin, northern Yukon, Canada: insights to permafrost hydrogeology and karst. *Arctic and Alpine Research*.
- FORD, D.C., 1987. Effects of glaciations and permafrost upon the development of karst in Canada. *Earth Surface Processes and Landforms*, 12: 507-521.
- FORD, D.C. et WILLIAMS, P., 1989. Karst geomorphology and hydrology. Unwin Hyman, London, 601p
- HARMON, R.S., FORD, D.C. et SCHWARZ, H.P., 1977. Interglacial chronology of the Rocky and Mackenzie Mountains based on $^{230}\text{Th}/^{234}\text{U}$ dating of calcite speleothems. *Canadian Journal of Earth Sciences*, 14: 2543-2552.
- HUGHES, O.L., 1971. Northern Yukon Territory and Northwest District of Mackenzie. Surficial Geology. Geological Survey of Canada. Map 1319 A.
- LAURIOL, B., CARRIER, L. et THIBAudeau, P., 1988. Topoclimatic zones and ice dynamics in the caves of the northern Yukon. Canada. *Arctic*, 41: 215-220.
- LAURIOL, B., CINQ-MARS, J. et CLARK, I.D., 1991. Localisation, genèse et fonte de quelques névés du Yukon, Canada. *Permafrost and Periglacial Processes*, 2: 225-236.
- LAURIOL, B. et CLARK, I.D., 1993. An approach to determine the origin and age of massive ice blockages in two arctic caves. *Permafrost and Periglacial Processes*, 4: 77-85.
- LAURIOL, B., CLARK, I.D. et PRÉVOST, C., 1994. Étude d'une glace de la fin de l'hypsithermal dans une caverne du nord du Yukon, Canada. Actes du 3^e symposium international Cavités glaciaires et cryokarst en régions polaires et de haute montagne. Chamonix, France. In (Griselin, ed.): Annales littéraires de l'université de Besançon, n° 561, série Géographie, Besançon, 1995, pp:89-92.
- Lauriol, B., Ford, D.C., CINQ-MARS, J. et MORRIS, W.A. 1997 (soumis). The chronology of speleothem deposition in northern Yukon and its relationship to permafrost, *Canadian Journal of Earth Sciences*.
- NORRIS, D.L., 1980. Geology of Northern Yukon and Northwest District of Mackenzie. Geological Survey of Canada. Map 1581A.
- THIBAudeau, P., ROBERGE, J. et LAURIOL, B., 1988. Agressivité chimique des eaux dans les massifs calcaires du nord du Yukon. Canada. *Revue de Géomorphologie Dynamique*, 37: 61-74.
- SWEET, T. K., 1974. Calcrete crusts in an arctic permafrost environment. *American Journal of Sciences*, 274: 1059-1063.
- VAN EVERDINGEN, R.O., 1981. Morphology, hydrology and hydrochemistry of karst in permafrost near Great Bear Lake, Northwest Territories. National Hydrological Research Institute of Canada, Paper 11.

Remerciements

Les auteurs remercient Énergie, Mines et Ressources Canada pour l'aide logistique (Étude du Plateau Continental Polaire, projets 666-95, 639-95, 512-95). L'étude a été financée par des subventions CRSNG (octrois OGP 0007995 à Ian Clark et OPG 0042590 à Bernard Lauriol) et par le Ministère des Affaires Indiennes et du Nord. Les auteurs remercient aussi la communauté d'Old Crow pour son aide et son accueil et les étudiants qui ont participé aux nombreux travaux et analyses de terrain et de laboratoire, plus particulièrement Caroline Duchesne, Clément Prévost, Luc Carrier et Pierre Thibaudeau.

Mots clefs:

Canada, Yukon, cavernes, pergélisol, permafrost, aufeis, eaux souterraines, glaces souterraines, dépôts de calcite, processus cryogéniques.

Caractéristiques hydrogéologiques de deux aquifères calcaires des Préalpes romandes

par Jean-Christophe Maréchal, Michel Looser & Antonio Dematteis
Laboratoire de Géologie de l'École Polytechnique Fédérale de Lausanne, CH-1015 Lausanne

Abstract

The Avants Great Spring and the Grandchamp springs are the emergences of two karstic aquifers of the Prealpin type. Both are characterised by a hydrogeological basin well delimited by the tectonics and without anthropic influence. They are exploited by means of three galleries situated near the base of the aquifer. These three springs are connected to the network of the water services of Vevey-Montreux : they supply a mean flow nearing 20 000 l/min.

The Avants aquifer is constituted by Lias fissured limestone which plays the role of reservoir while the Grandchamp aquifer is situated within the Malm karstified limestone. Flows are directed by local tectonics : they are concentrated respectively in Planniaz and Rochers de Naye synclinals. The base of the aquifer is constituted by Trias marls and limestone for the former and by Dogger marls in the latter. The time series of discharges have been used to characterise the hydrodynamic functioning of each of the aquifers. It reveals their different response to the melting of snow, in relation with the structure of the karst. The study of the hydrochemical behaviour of the two aquifers allows us to validate the decomposition of hydrograms. Analysis of trace elements in solution in the water has shown the influence of evaporitic rocks, which necessitates a new approach of tectonics usually admitted in this area. The variation of sulphate quantities allow us to localise evaporates in the saturated zone of the aquifer.

Résumé

La Grande Source des Avants et les sources de Grandchamp illustrent deux aquifères karstiques de type Préalpin. Toutes deux sont caractérisées par un bassin hydrogéologique bien délimité par la tectonique et sans influence anthropique importante. Elles sont captées à l'aide de galeries situées au niveau du plancher d'écoulement. Ces trois sources qui alimentent le réseau du Service des Eaux de Vevey-Montreux (SEVM), fournissent globalement un débit moyen de près de 20'000 l/mn.

L'aquifère des Avants est constitué des calcaires fissurés du Lias qui forment la roche réservoir tandis que l'aquifère de Grandchamp se situe dans les calcaires karstifiés du Malm. Les écoulements sont guidés par la tectonique locale : ils sont concentrés respectivement dans les synclinaux de la Planniaz et des Rochers de Naye. Le plancher des écoulements dans le premier est constitué par les marnes et calcaires du Trias tandis que dans le second le niveau de base est formé par les marnes du Dogger. Le suivi temporel des débits a été utilisé pour caractériser le fonctionnement hydrodynamique de chacun des deux aquifères. Il met en évidence notamment leur réponse différente à la fonte des neiges, en relation avec la structure du karst. L'étude du comportement hydrochimique des deux sources a permis de valider la décomposition des hydrogrammes de crue. L'analyse des éléments en traces en solution dans les eaux a par ailleurs mis en évidence l'influence de roches évaporitiques, ce qui nécessite une interprétation nouvelle de la tectonique généralement admise dans cette région. Les variations des teneurs en sulfates permettent de localiser celles-ci dans la zone noyée de l'aquifère.

1. Introduction

Les aquifères calcaires fissurés des Alpes ont été peu étudiés jusqu'à présent. Pourtant, ils représentent une importante ressource dans des régions où les besoins en eau ne cessent de croître suite notamment au développement touristique. Les informations acquises sur les débits et caractéristiques hydrochimiques des deux sources étudiées dans ce travail permettent de mieux cerner le mode de circulation des eaux dans ce type d'aquifère, différent par ses caractéristiques hydrogéologiques des aquifères karstiques jurassiens ou pyrénéens. Situées au bord du Lac Léman, sur le flanc des Préalpes Romandes, les zones sourcières des Avants et de Grandchamp sont d'importance majeure; elles alimentent le réseau du Service des Eaux de Vevey-Montreux (SEVM).

2. Situation géologique et hydrogéologique

Les deux bassins sourciers se situent dans les Préalpes médianes, unité tectonique formée d'une succession d'anticlinaux et de synclinaux d'axe SW-NE (Badoux, 1965; Weidmann, 1993).

Sources de Grandchamp - aquifère calcaire du Malm:

Les sources de Grandchamp, ont été réalisées entre 1907 et 1913 sous la direction du géologue Maurice Lugeon. Deux galeries, "le Confin du Renard" (290 m de long) et "de Repremier" (130 m de long), permettent de capter un débit moyen d'environ 9'000 l/mn. Le bassin hydrogéologique des sources de Grandchamp (figure 1) est limité tectoniquement au synclinal des

Rochers de Naye. Le niveau de base des écoulements est constitué par le Dogger formé essentiellement de marnes et marno-calcaires et de calcaires spathiques à silex. Le Malm est le siège principal de l'aquifère: il est constitué de calcaires à pâte fine, parfois à silex, en bancs massifs qui forment les parois et les arêtes de la région. Le coeur du synclinal est formé des terrains calcaires et marno-calcaires d'âge Crétacé, moins perméables.

La couverture quaternaire est rare, limitée à quelques placages de moraine locale et à des voiles d'éboulis. Des indices de karstification sont présents. Un lapiez partiellement recouvert subsiste sur les calcaires du Malm au NE du massif des Rochers de Naye qui abrite de nombreuses cavités. L'altitude du bassin oscille entre 2045 m (Rochers de Naye) et 526 m (galerie du Confin du Renard), pour une altitude moyenne de 1500 m. Le bassin hydrogéologique, très allongé, possède une longueur d'environ 6.5 km pour une largeur moyenne de 800 m.

Sources des Avants - aquifère calcaire du Lias:

La Grande source des Avants captée vers 1888 sur les conseils des géologues A. Heim et E. Renevier, à l'aide d'une galerie d'environ 20 m, fournit en moyenne 10'000 l/mn.

Le bassin hydrogéologique de la zone sourcière des Avants est limité tectoniquement par le synclinal de la Planniaz. Généralement, les marnes et calcaires du Trias forment le plancher des écoulements qui ont lieu dans le synclinal. Le siège de l'aquifère est lié à la base du Lias, constitué de calcaires

siliceux. Les marnes schisteuses et les calcaires argileux du Dogger forment le toit de l'aquifère, moins perméable.

La couverture quaternaire est limitée à quelques placages de moraine locale. Les calcaires du Lias, siliceux, n'autorisent pas le développement de lapiez, mais les nombreuses fractures qui affectent le front de la nappe permettent l'apparition de châteaux (torrents) qui favorisent l'infiltration des eaux de ruissellement lors des pluies. L'altitude du bassin oscille entre 1800 m (Pierra Perchia) et 1033 m (Grande source des Avants), pour une altitude moyenne de 1300 m. Le bassin a une longueur de près de 10 km pour une largeur moyenne de 900 m.

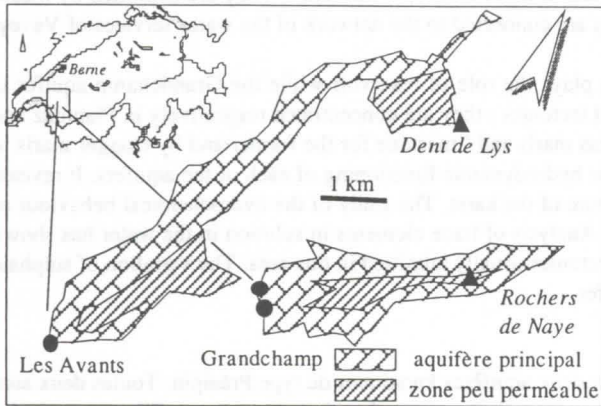

Figure 1 : Carte géologique simplifiée des 2 aquifères étudiés

3. Examen des hydrogrammes

Mise en évidence d'un phénomène de trop-plein

Des mesures de débits ont été effectuées hebdomadairement aux sources entre 1987 et 1994. Les trois sources sont caractérisées par un régime de type nivo-pluvial (figure 2) : une forte crue au printemps liée à la fonte des neiges est suivie d'une récession soutenue par les pluies d'automne qui peuvent être, selon les années, à l'origine de pics secondaires ou d'une crue aussi importante qu'au printemps (exemple de l'automne 1992).

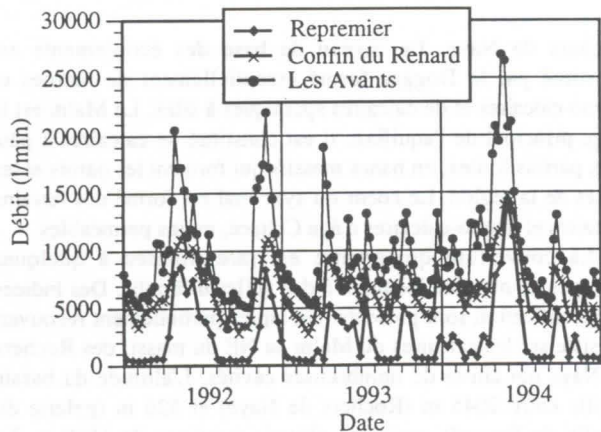

Figure 2 : Hydrogramme des trois sources (période 1992-1994).

La source de Repremier se distingue par l'existence de périodes de décrues très marquées. Tandis que les débits des deux autres sources sont soutenus et décroissent progressivement, celui de la galerie de Repremier décroît très rapidement et reste constant à moins de 500 l/min. Son rapport Q_{MAX}/Q_{MIN} est dix fois supérieur à ceux de Confin et Les Avants (tableau 1).

Source	Q_{MOY}	Q_{MIN}	Q_{MAX}	Q_{MAX}/Q_{MIN}
Les Avants	9859	3200	27300	8,5
Confin du Renard	6430	1742	15850	9,1
Repremier	2510	132	14400	109

Tableau 1 : Principales caractéristiques des hydrogrammes des trois sources (période 1987-1994)

La galerie de Repremier, distante de 250 m et située à une altitude plus élevée (40 m) que le Confin du Renard, semble jouer le rôle de trop-plein de celle-ci. Ceci est illustré par le graphique de la figure 3 qui met en relation le débit au Confin du Renard avec celui de Repremier. On voit en effet que, pour des débits inférieurs à 5800 l/min au Confin du Renard, la galerie de Repremier draine moins de 600 l/min. La relation entre les débits des deux galeries est linéaire avec un coefficient angulaire égal à 0,08. Au delà de 5800 l/min, la galerie de Repremier commence à fonctionner en trop-plein de sorte que les débits augmentent linéairement beaucoup plus rapidement (coefficient angulaire = 1,36) pour atteindre en période de crue un débit semblable à celui du Confin du Renard.

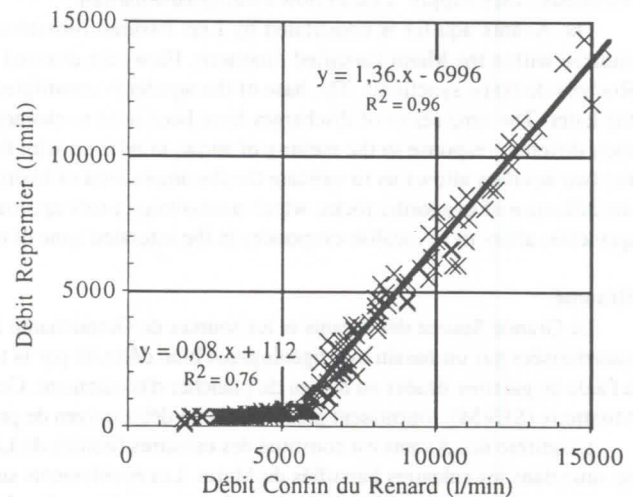

Figure 3 : Relation entre le débit au Confin du Renard et le débit à Repremier (période 1987-1994).

Afin d'étudier la réponse hydrogéologique de l'aquifère de Grandchamp, il convient donc de considérer la somme des débits de Repremier et Confin du Renard. La comparaison du régime hydrogéologique des deux aquifères de Grandchamp et Les Avants est alors possible (figure 4).

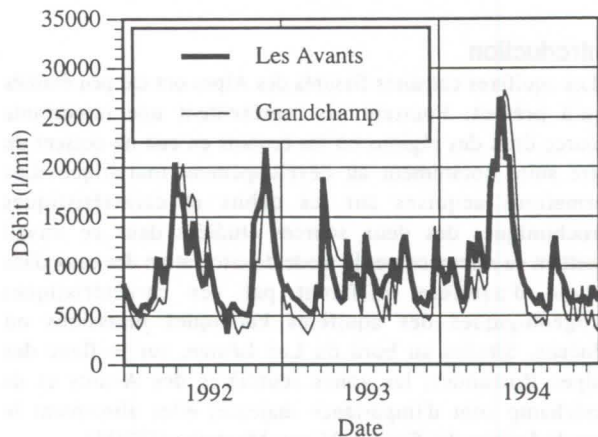

Figure 4 : Hydrogrammes des sources de Grandchamp et Les Avants

Les deux hydrogrammes sont très semblables avec des cycles de pics et récessions quasi simultanés. Le pic des crues de printemps est souvent en avance aux Avants. Les pics des crues sont égaux aux émergences des deux aquifères; on constate toutefois un débit de base légèrement inférieur à Grandchamp.

Décomposition des hydrogrammes

La méthode d'ajustement des hydrogrammes par une fonction exponentielle et une fonction homographique, développée par Mangin (1975) à l'intention des aquifères karstiques a été appliquée aux deux aquifères étudiés. Elle consiste à séparer un

épisode de récession après une crue, en deux composantes. L'une correspond à l'infiltration rapide à travers la zone non saturée (décrue) et l'autre à la vidange lente du karst noyé (tarissement). La première est ajustée au moyen d'une fonction homographique tandis que la seconde l'est selon le modèle exponentiel de Maillet (1905).

L'équation du débit à la source en fonction du temps s'écrit :

$$Q_t = q_0^b \cdot e^{-\alpha \cdot t} + q_0^* \cdot \frac{1 - \eta t}{1 + \varepsilon t}$$

où les paramètres α , ε et η [j^{-1}] traduisent les caractéristiques de l'aquifère.

Les ajustements (figure 5) ont été effectués durant la récession du printemps 94 sur une série de débits hebdomadaires.

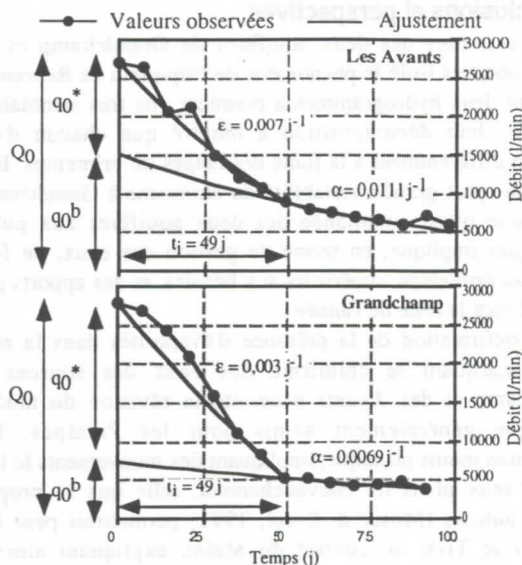

Figure 5 : Décomposition de la récession du printemps 1994

La décroissance du débit de base (courbe de tarissement) est plus rapide aux Avants ($\alpha = 0,0111 j^{-1}$) qu'à Grandchamp ($\alpha = 0,0069 j^{-1}$). Ce paramètre de vidange indique que la transmissivité de la zone noyée aux Avants est supérieure à celle de Grandchamp. La forme de la décrue rapide est par ailleurs semblable aux deux sources : les paramètres qui la caractérisent sont en effet très proches. Les durées ($t_i = 1/\eta$) sont égales (49 jours) et les concavités des courbes diffèrent peu ($\varepsilon = 0,007 j^{-1}$ aux Avants et $0,003 j^{-1}$ à Grandchamp).

L'examen des volumes drainés par les sources (tableau 2) permet de déterminer la part respective de chacune des composantes dans le débit total des sources.

	Q_0	q_0^b	q_0^*/Q_0	V_0	V_0^b / V_0	V_0^*/V_0
	(l/min)	(l/min)	(%)	(m^3)	(%)	(%)
A	27000	15249	43.522	2352288	84.1	15.9
G	27799	7354	73.546	2221662	69.1	30.9

Tableau 2 : Débits et volumes caractérisant la récession (A : Avants - G : Grandchamp)

Les volumes totaux (V_0) s'écoulant aux deux sources sont similaires; dans les deux cas, la part du volume lié au tarissement (V_0^b) est supérieure à la part due à la vidange rapide (V_0^*). A Grandchamp, la zone d'infiltration rapide est plus développée en termes de volume qu'aux Avants. L'existence d'un épikarst et d'un réseau karstique en surface bien développés à Grandchamp font en sorte que le volume d'eau transitant rapidement sans passer par la zone saturée est plus important qu'aux Avants. Il en résulte une plus grande dépendance du régime hydraulique par rapport aux conditions climatiques.

4. Caractéristiques physico-chimiques des eaux

Évolution et variation du chimisme

La conductivité électrique, indicatrice de la minéralisation totale, diminue dans les deux sources lorsque les débits augmentent au moment de la fonte des neiges du printemps (figure 6a). Ce phénomène de dilution est plus marqué à la source du Confin du Renard (Grandchamp) qu'à la Grande source des Avants. Ceci est en accord avec les résultats de la décomposition des hydrogrammes. Les circulations rapides au travers de la zone d'infiltration, peu minéralisées (provenant de la fonte des neiges), sont plus importantes à Grandchamp et marquent de manière plus notable le chimisme de la source. Il est possible de quantifier ce phénomène. Pour cela on résout un simple modèle de mélange entre des eaux peu minéralisées liées à la décrue rapide et des eaux fortement minéralisées liées au tarissement de l'aquifère.

L'équation de mélange s'écrit au temps $t=0$, (pic de crue) :

$$Q_0 \cdot \sigma_{Q_0} = q_0^b \cdot \sigma_{q_0^b} + q_0^* \cdot \sigma_{q_0^*}$$

où σ désigne la conductivité électrique des différentes composantes du débit à la source. Les conductivités utilisées sont $60 \mu S/cm$ pour l'eau de fonte de neige ($\sigma_{q_0^*}$) et la conductivité généralement observée lors des faibles débits (absence de flux rapide) pour la phase de tarissement ($\sigma_{q_0^b}$). En reprenant les valeurs des débits déterminées lors de la décomposition des hydrogrammes, on peut recalculer la conductivité globale σ_{Q_0} de la source en période de crue (tableau 3). On obtient bien à peu près les conductivités observées aux deux sources lors des crues le 23 mai 1994 (valeurs observées : aux Avants $\sigma_{mes} = 321 \mu S/cm$ et à Grandchamp $\sigma_{mes} = 253 \mu S/cm$).

	q_0^b	$\sigma_{q_0^b}$	q_0^*	$\sigma_{q_0^*}$	Q_0	σ_{Q_0}
	(l/min)	($\mu S/cm$)	(l/min)	($\mu S/cm$)	(l/min)	($\mu S/cm$)
A	15249	535	11751	60	27000	328
G	7354	700	20445	60	27799	229

Tableau 3 : Termes de l'équation de mélange et calcul de σ_{Q_0} (A : Avants - G : Grandchamp)

La similitude entre les conductivités calculées et observées (écarts inférieurs à 10 %) permet de valider le modèle d'écoulement aux deux sources : soit une décrue rapide peu minéralisée ($60 \mu S/cm$) liée à la fonte des neiges et un débit de base plus minéralisé ($535 \mu S/cm$ aux Avants et $700 \mu S/cm$ à Grandchamp) lié au tarissement de l'aquifère.

Composition chimique et origine des eaux

Les analyses chimiques des eaux (tableau 4 et figure 6b) montrent qu'en débits moyens et élevés les eaux des deux sources sont de type bicarbonaté calcique sulfaté, faiblement magnésien (de type $Ca-(Mg)-HCO_3-SO_4$ selon la classification de Jäckli, 1970). En basses eaux, au Confin du Renard les eaux deviennent plus sulfatées (type $Ca-(Mg)-SO_4-HCO_3$), aux Avants le type d'eau reste plus stable, bien que le pourcentage de magnésium augmente légèrement (type $Ca-Mg-HCO_3-SO_4$). La présence de sulfates en quantités appréciables (médiane > 90 mg/l, tableau 4) n'est pas chose courante dans les aquifères carbonatés. Les aquifères typiques des formations calcaires possèdent une teneur médiane égale à 10 mg SO_4/l (Dematteis, 1995). L'origine des sulfates dans les eaux n'est pas inconnue et leur présence est généralement liée aux roches évaporitiques. Dans le cas des sources de Grandchamp et des Avants, cette origine n'est pas évidente a priori, puisque selon la géologie généralement admise, le Trias qui contient du gypse, est séparé des deux aquifères de respectivement 600 et 100 mètres de marnes.

	Confin du Renard			Les Avants		
	N	MAX	MED	N	MAX	MED
T°C	110	8.8	7.9	33	7.2	6.8
pH	198	8.40	7.70	50	8.40	7.87
Conductivité (µS/cm)	199	942	532	50	613	483
Alcalinité (mg/l CaCO ₃)	199	183.0	155.0	50	175.0	153.3
Dur. tot. [°F]	198	55.4	29.6	49	31.9	25.2
Dur. carb. [°F]	199	18.3	15.5	49	17.5	15.3
Dur. perm. [°F]	198	40.6	13.6	49	16.0	9.5
HCO ₃ (mg/l)	7	253.2	207.4	8	210.5	199.8
Ca (mg/l)	93	184.8	97.4	33	101.2	78.6
Cl (mg/l)	194	5.0	1.1	50	7.0	1.0
Fe (mg/l)	71	0.4	0.0	19	0.2	0.1
H ₄ SiO ₄ (mg/l)	3	13.6	13.2	4	15.5	14.4
K (mg/l)	47	2.9	0.7	25	0.8	0.4
Mg (mg/l)	92	98.1	7.8	33	18.4	11.9
Na (mg/l)	47	8.9	2.7	25	5.7	1.8
NO ₃ (mg/l)	144	5.4	1.7	46	3.2	2.0
SO ₄ (mg/l)	160	397.4	97.8	45	158.2	92.4
Sr (mg/l)	3	2.4	1.3	3	1.5	1.4
B (µg/l)	3	55.9	33.8	3	28.6	25.0
Ba (µg/l)	3	104.4	95.9	3	11.6	10.6
Br (µg/l)	3	3.0	1.7	3	2.7	2.5
I (µg/l)	3	44.1	17.3	3	28.4	13.3
Li (µg/l)	3	8.1	5.9	3	3.9	3.3
Mo (µg/l)	3	1.2	0.6	3	1.0	1.0
U (µg/l)	3	0.6	0.4	3	0.4	0.4

Tableau 4 : Paramètres chimiques mesurés au Confin du Renard (Grandchamp) et aux Avants. (N=nombre d'analyses)

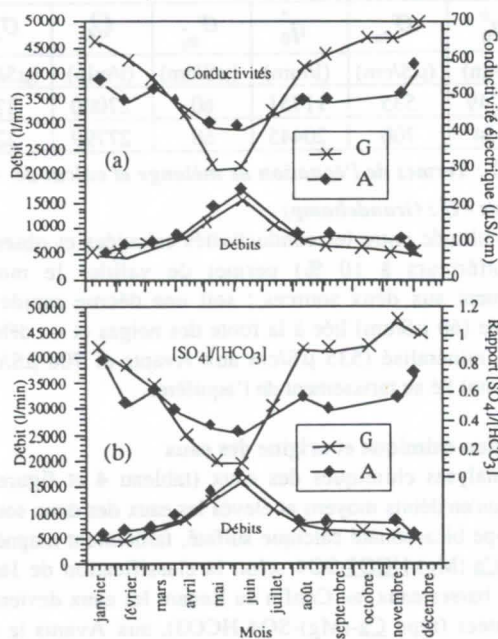

Figure 6 : Moyennes mensuelles de la conductivité électrique (a) et de la teneur relative en sulfates (b) parallèlement aux variations de débit (période 1959-1992).

Les aquifères évaporitiques du Trias dans le bassin Lémanique du Rhône présentent des anomalies importantes en magnésium et strontium et plus faible en lithium et bore (Dematteis 1995). Ces éléments se retrouvent en teneurs anormales dans les eaux de Grandchamp et des Avants (tableau 4) ce qui permet de suspecter une influence évaporitique. Le baryum, dont la teneur est près de 10 fois plus élevée dans les sources de Grandchamp (104 µg/l) qu'à la source des Avants, marque bien l'influence des calcaires du Malm (Dematteis, 1995).

Le rapport SO_4/HCO_3 augmente lorsque le débit diminue (figure 6b). Le marquage géochimique des eaux de décrue rapide (bicarbonatées) est différent de celui des eaux du flux de base (très sulfatées). Celles-ci sont plus sulfatées suite à leur circulation dans la zone noyée à proximité du plancher de l'aquifère, en contact avec les roches évaporitiques supposées présentes au cœur des synclinaux. Par ailleurs le rapport est nettement supérieur à Grandchamp, ce qui indique une plus forte présence d'évaporites au sein de l'aquifère. Les teneurs en éléments traces indicateurs d'évaporites (magnésium, lithium, bore et strontium) sont d'ailleurs toutes supérieures à Grandchamp.

5. Conclusions et perspectives

Les exutoires des deux aquifères de Grandchamp et des Avants, une fois isolé le phénomène de trop-plein de Repremier, possèdent deux hydrogrammes à première vue très semblables. Toutefois, leur décomposition a montré que chacun d'eux répondait différemment à la fonte des neiges du printemps. Il en résulte une plus grande variabilité du chimisme à Grandchamp. La réponse quasi simultanée des deux aquifères aux pulses climatiques implique, en terme de gestion des eaux, de forts apports au printemps, supérieurs aux besoins, et des apports plus faibles durant le reste de l'année.

La confirmation de la présence d'évaporites dans la zone noyée, marquant le chimisme des eaux des sources de Grandchamp et des Avants nécessite la révision du modèle tectonique généralement admis pour les Préalpes. Une déformation moins plastique, impliquant des mouvements le long de nombreux plans de chevauchement, telle que la propose certains auteurs (Mosar & Borel, 1992) permettrait peut être d'amener le Trias au contact du Malm, expliquant ainsi le marquage chimique des eaux de Grandchamp et des Avants par des roches évaporitiques. L'étude du chimisme des autres grands aquifères en roches carbonatées de la région de Montreux permettra de vérifier si un tel modèle se justifie ou s'il faut rechercher le taux de sulfates de Grandchamp dans une anomalie purement locale.

Remerciements

Les auteurs remercient M. Lauener, directeur du SEVM, et MM. Keller et Aerny pour leur disponibilité et leur collaboration.

Références

- BADOUX, H. 1965 : Atlas géologique de la Suisse, feuille 1264 Montreux. *Commission géologique Suisse*.
- DEMATTEIS, A. 1995 : Typologie géochimique des eaux des aquifères carbonatés des chaînes alpines en Europe centrale et méridionale. *Thèse EPFL*, 1995.
- JÄCKLI, H. 1970 : Kriterien zur Klassifikation von Grounwasservorkommen. *Eclogae geol. Helv.*, 63/2, p 389-434.
- MANGIN, A. 1975 : Contribution à l'étude hydrodynamique des aquifères karstiques. *Thèse de doctorat, Univ. Dijon*, 258 pp.
- MOSAR, J. & Borel, G. 1992 : Paleostress from the Préalpes Médiannes (Switzerland). *Annales Tectonicae*. Vol VI n.2 pp115-133.
- SEVM (1956 - 1994) : Sources des Avants et de Grandchamp. *Archives du Service des Eaux de Vevey-Montreux (SEVM)*.
- WEIDMANN, M. 1993 : Atlas géologique de la Suisse, feuille 1244 Châtel-St-Denis. *Commission géologique Suisse*.

Aspect hydraulique de l'écoulement karstique et ses conséquences sur le fonctionnement du système aquifère

par Borivoje F. Mijatović,

Institut de l'aménagement des eaux, Université de Novi Sad, Place D. Obradovića 8. Yougoslavie

Abstract

Methodological approach of studying groundwater karstic flow needs different adaptation of scheme for system aquifer. This approach is based on units of two types of groundwater circulation: (1) macroscopic circulation through privileged channels, which formed the drainage network, and (2) microscopic circulation through the system of fine fissures in block-matrices of aquifers. The last one performs the function of groundwater storage, which feeds the drainage network of privileged collectors.

Résumé

Une approche méthodologique dans l'étude d'écoulement karstique nécessite une adaptation au schéma du système aquifère, dans lequel l'eau s'écoule à travers un réseau des conduits ouverts et diversement connectés entre les zones faiblement perméables par rapport au réseau. Ce modèle du système aquifère, au point de vue hydraulique, peut être considéré comme dû à la réunion de deux types de circulation souterraine: (1) une circulation macroscopique dans les conduits privilégiés, formant ainsi le réseau d'écoulement, et (2) une circulation microscopique dans des itinéraires secondaires au dedans des blocs-matrices, qui assument la majeure partie de la fonction de stockage du système aquifère et alimentent le réseau des conduits privilégiés.

1. Introduction

L'organisation discontinue particulière du milieu aquifère que nous observons sur le terrain karstique, couvre l'ensemble des eaux comprises dans le réseau de conduits et dans les blocs-matrices interconnectés dans la zone saturée du système aquifère. Ceci permet de qualifier l'écoulement karstique comme dû à la réunion de deux types de circulation: (1) une circulation macroscopique dans les itinéraires privilégiés (larges fissures, chenaux, cavités) consistant une sorte de réseau d'écoulement, et (2) une circulation microscopique dans les itinéraires secondaires (réseaux de petites fissures) des blocs-matrices ainsi délimités, qui assument la majeure partie de la fonction de stockage du massif karstique et alimentent le réseau d'écoulement privilégié.

Dans l'optique de présente communication, l'objectif majeur est d'examiner ces systèmes d'écoulement souterrain, définis par le champ de potentiel hydraulique (ϕ) et de flux des écoulements (\bar{q}). Pour y parvenir, on aura besoin de disposer de caractères physiques du milieu aquifère (la perméabilité et l'emménagement), ce qui doit permettre de rendre compte au aspect hydraulique des multiples comportements des écoulements karstiques et ses conséquences sur le fonctionnement du système aquifère.

2. Base structurale du système aquifère

Pour l'étude de l'évolution de la karstification et des écoulements souterrains une approche théorique de la déformation apparaît fondamentale. Il s'agit donc du processus de rupture des roches carbonatées qui met en jeu notamment les relations angulaires entre plans des ruptures et directions des contraintes principales; ceci permet d'apprécier l'héritage morphologique relatif aux diverses reprises des phases tectoniques, en compression et en distension. On retrouve ainsi au niveau structural supérieur l'ensemble des discontinuités d'origine tectonique dont l'identification de façon précise peut être établie à partir d'une classification cinématique, compte tenu des modèles théoriques de déformation.

L'approche structurale, tectonique et microtectonique, permet donc, de distinguer et d'individualiser à l'échelle du massif et de l'affleurement, trois principaux groupes de fissures ou de ruptures: - fissures de tension, - fissures de compression ou de relâchement, et - fissures de cisaillement conjuguées (dextres et senestres) (figure 1).

Les nombreuses mesures effectuées sur les affleurements de roches carbonatées apportent la confirmation de ce modèle théorique, pouvant expliquer l'apparition des fissures, leurs relations angulaires et leur rôle lors des déformations.

L'orientation des contraintes principales, celles de σ_1 , σ_2 et σ_3 par rapport aux déformations, conditionne son jeu par le développement de ces trois types de fractures, soit en ouverture, soit en fermeture et influe par ce biais sur la perméabilité du milieu fissuré. Dans les conditions d'un état de contrainte triaxial, on s'aperçoit que les fractures les plus favorables à une ouverture seront celles proches d'une position orthogonale à σ_3 (contrainte minimale) alors que les fractures orthogonales à σ_1 (contrainte maximale) auront tendance à se fermer. Quant aux fractures de cisaillement conjuguées elles traduisent un type de discontinuité marqué par des accidents de décrochement, très favorables pour un développement notable des écoulements souterrains (figure 2).

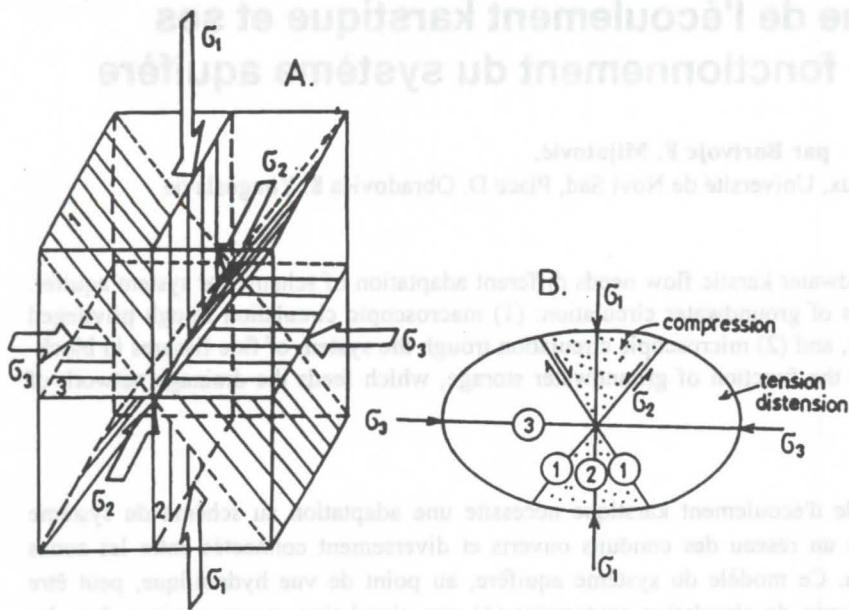

Figure 1 : Relation entre les principales contraintes tectoniques et principaux groupes de fissures. A - Blocdiagramme, B - Ellipse de déformation. 1 - Fissures de cisaillement conjuguée (dextres et senestres), 2 - Fissures de tension, 3 - Fissures de compression ou de relâchement.

3. Particularités de réactions hydrauliques du système aquifère

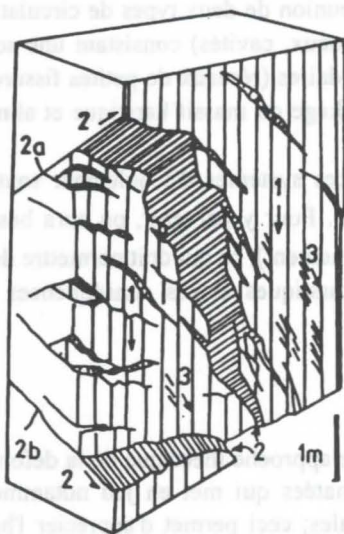

Figure 2 : Blocdiagramme des failles observées dans terrains calcaires: les trois jeux successifs sont numérotés 1(normal), 2(inverse), 3(normal); les failles inverses 2a et 2b sont conjuguées.

Bien que le milieu karstique se présente hétérogène et anisotrope il peut être opérationnalisé par la reconnaissance d'une structuration et hiérarchisation de deux différents champs de caractères physiques, l'un dans des blocs-matrices et l'autre dans des réseaux de conduits. A ce propos la structure complexe de champs de distribution spatiale de majeurs paramètres physiques, tels que perméabilité et porosité, se caractérise par: (1) la distribution statistique dans les blocs-matrices, (2) la distribution ponctuelle dans les réseaux des écoulements et (3) l'effet d'échelle sur ces champs.

Ces considérations, pourtant, demandent à être bien distinguées, notamment dans le domaine de fracturation des

Au point de vue hydrogéologique on peut remarquer que les écoulements souterrains, étroitement liés à la perméabilité et au gradient hydraulique sont une résultante d'une interaction beaucoup plus complexe des composantes tectoniques structurales et de champ des vecteurs vitesse des écoulements plutôt qu'une fonction simple de la densité de fracturation. L'étude de l'évolution de fissuration et de karstification, par conséquent, implique non seulement une connaissance approfondie des aspects pétrologique-lithologique, tectonique-structurale et paléogéographique, mais aussi elle devrait porter sur la dynamique des écoulements, profondément modifiée en fonction du gradient hydraulique et de la vitesse d'écoulement, intimement liés au degré de la karstification.

Dans les régions karstiques les séries chronologiques de pluie et de débit, leurs analyses corrélatoires-spectrales et les réponses naturelles du système aquifère (par des variations de potentiel et de vitesses d'écoulement) en périodes de crue et d'étiage, mettent en évidence un modèle général pour le magasin karstique. Ce modèle confirme, plus ou moins, une schématisation effectuée sur le comportement du système aquifère: les blocs-matrices, fissurés et faiblement perméables, sont drainés par un réseau des conduits extrêmement perméables. Dans la zone saturée le réseau de conduits karstiques draine les blocs matriciels en périodes d'étiage et les aliment en périodes de crue (figure 3).

C'est un phénomène connu comme l'inversion du gradient hydraulique (DROGUE, 1980). Les écoulements microscopiques dans les blocs-matrices, responsables pour l'aptitude à emmagasiner l'eau souterraine seraient semblé à une variété de circulation lente (filtration de Darcy). D'autre part les écoulements dans les conduits du réseau karstique, correspondant de temps en temps aux vrais rivières souterraines à caractère torrentiel, rendent les flux et les potentiels hydrauliques, sur l'ensemble du système aquifère, irréguliers et perturbants.

Ces comportements particuliers apportent constamment sa vérification dans différents sites auprès des grandes zones de drainage karstique (captages en galérie drainante sur la côte dalmate - MIJATOVIC, 1984; source du Lez, source du Lamalou, site du Terrieu - GAO XU, 1990).

massifs calcaires, qui sont sous l'influence de l'effet d'échelle. Il se pose alors la question sur la répartition des valeurs de perméabilité et de porosité efficace sur l'ensemble du système aquifère lorsque l'échelle varie.

Quelques résultats des paramètres physiques et hydrauliques observés dans les aquifères karstiques

Plusieurs auteurs se sont penchés sur le problème de la représentativité des mesures ponctuelles de la perméabilité, exprimée par le coefficient K (LT^{-1}). Cependant, il faut remarquer, qu'au sens classique du terme, la perméabilité caractérisant les milieux homogènes et anisotropes peut être ainsi adoptée pour les blocs-matrices fissurés comme un tenseur de perméabilité. Pour les réseaux d'écoulements karstiques il convient d'appliquer la notion de conductivité hydraulique, qui est "l'aptitude d'un conduit naturel ou d'un ensemble de conduits, dans un milieu aquifère discontinu, à permettre le mouvement de l'eau sous l'effet d'un gradient de charge hydraulique donné, dans la direction diffère en général de celle de l'écoulement" (CASTANY & MARGAT, 1977).

Dans trois régions du karst Dinarique (Buško blato, Peruća, Kruščica - 3 barages de retenue) une analyse statistique de perméabilité, par essais d'injection d'eau de type Lugeon, a été procédée par BORELLI et PAVLIN (1967), sur l'hypothèse de la corrélation entre caractères physiques des roches carbonatées et l'apparition possible de cavernes et conduits karstiques. La distribution des mesures de perméabilité est présentée de façon exemplaire par des courbes de fréquence cumulative: de 80 à 95% de valeurs présentées se situent entre $1 \cdot 10^{-6}$ et $5 \cdot 10^{-5}$ m/s. Dans les forages décrits, la perméabilité diminue nettement avec la profondeur, suivant la loi exponentielle (les valeurs élevées se trouvent dans la premiers 60 m des forages). On peut s'apercevoir qu'il y a de fortes chances pour que la tendance exprimée ne soit plus démontrable, à partir d'une certaine profondeur où des tests statistiques sont très approximatifs, à cause de la dispersion de valeurs mesurées (BORELLI & PAVLIN, 1967). Les distributions citées caractérisent en effet les blocs-matrices à petite échelle, volumineux mais peu perméables, avec une fissuration prédominante et fine.

En ce qui concerne les valeurs du coefficient d'emmagasinement S , il n'existe pratiquement aucune valeur sûre de ce paramètre dans les calcaires considérés en grandes dimensions. La porosité efficace ($m_e=S$) étant presque exclusivement liée au développement de karstification, elle peut être approchée de divers manières. Par des de pompage sur les forages profonds en Jura Suisse, dont la perméabilité ne dépasse pas une valeur de $5 \cdot 10^{-6}$ m/s les coefficients d'emmagasinement sont de l'ordre de 3 à 5 pour mille. Sur l'ensemble du bassin versant des systèmes aquifères karstiques dans Dinarides externes ces valeurs ne dépassent pas habituellement de 1 à 3%.

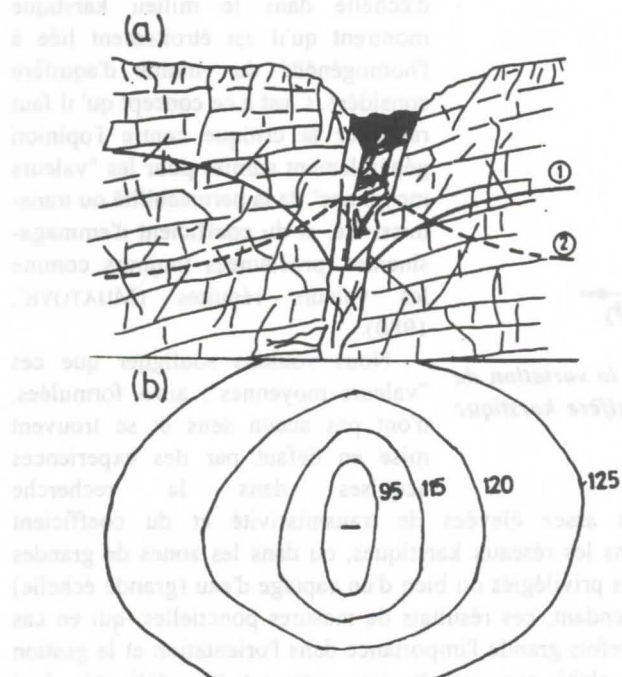

Figure 3 : (a) Schéma explicatif de multiple compartement d'écoulement karstique dans un système aquifère: (1) en périodes d'étiage, (2) en périodes de crue.

(b) Surfaces équipotentielle irrégulières affectées par un conduit d'écoulement privilégié, pendant la période d'étiage.

Les rares essais de pompage effectués directement dans les parties des réseaux karstiques très perméables (cavités, zones de sources) nous renseignent sur la perméabilité à grande échelle, donc sa distribution locale, car l'influence d'un tel essai s'étend loin, mais bien limité au dedans du réseau karstique; sur l'ensemble de l'aquifère cet influence ne touche que le réseau karstique.

Après avoir effectué un essai de pompage sur la source de Verdier en France, PALOC (1964) trouve une valeur de perméabilité de $9 \cdot 10^{-2}$ m/s à 10^{-1} m/s, et coefficient d'emmagasinement 0,038. MIJATOVIC (1970) calcule la transmissivité d'après les courbes de tarissement de deux sources karstiques au Liban (Safa et Barouk) et trouve une valeur de $T=9 \cdot 10^{-1}$ m²/s, et pour la source Jadro sur la côte dalmate la transmissivité s'élève à $T=4,7$ m²/s. Sur la côte Libanaise une campagne des essais de pompage dans une crevasse quaternaire (effondrée sur une zone des dolines karstiques dans les calcaires cenomano-turonien recouverts par les marnes senonien) a donné des résultats intéressants. Les calcaires sont en général compacts ($T=9,8 \cdot 10^{-5}$ m²/s dans certains forage F_3) mais ils peuvent présenter des zones karstiques très importantes ($T=1,3$ m²/s dans crevasse) avec une perméabilité entre 10^{-2} et 10^{-3} m/s. Les essais de pompage dans une galerie de captage avec un piézomètre, sur la côte dalmate, mérite d'être mentionné. Les coefficients T et S sont déterminés sur la base de deux essais de pompage en régime non-permanent (avec deux palier à part, 15 l/s et 40 l/s), à savoir: transmissivité étant de $1,4 \cdot 10^{-1}$ m²/s à $1,24 \cdot 10^{-2}$ m²/s et la coefficient d'emmagasinement de 0,0709 à 0,0976 (MIJATOVIC, 1980, 1984).

Une comparaison de différentes valeurs de perméabilité de transmissivité et de porosité efficace, obtenues dans les

forages et au laboratoire, dans les galeries drainantes et dans les zones de sources, montre clairement que l'effet d'échelle sur ces paramètres ne fait aucun doute. Ce phénomène est dû à la coexistence du réseau des conduits connectés de densité et du volume faible mais de perméabilité grande, et des blocs-matrices volumineux mais peu perméables. C'est pourquoi l'effet d'échelle joue le rôle prépondérant dans la détermination de limite de validité ou du rayon d'action des essais hydrauliques dans les aquifères karstiques.

Remarques générales

L'écoulement des eaux souterraines étant tributaire de l'homogénéité, on conçoit que dans les aquifères karstiques cette hypothèse n'a pas de signification réelle. Il en est ainsi, en particulier, des singularités ponctuelles que l'on trouve dans multiple comportement des écoulements.

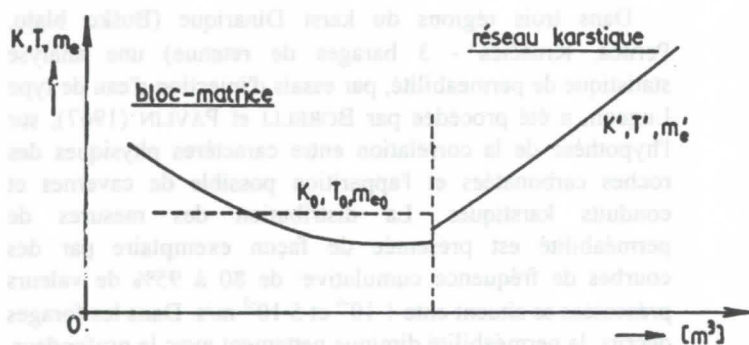

Figure 4 : Représentation schématique de l'effet d'échelle sur la variation de paramètres hydrogéologiques (K, T, m_e) dans un système aquifère karstique lorsque l'échelle varie.

hydrogéologique des aquifères karstiques. Ainsi, les valeurs assez élevées de transmissivité et du coefficient d'emmagasinement, obtenues sur la base des essais de débit dans les réseaux karstiques, ou dans les zones de grandes sources, sont représentatives à l'échelle d'un réseau d'écoulements privilégiés ou bien d'un captage d'eau (grande échelle) et non pas à l'échelle du système aquifère (petite échelle). Cependant, ces résultats de mesures ponctuelles, qui en cas d'extrapolation pourraient conduire à des graves erreurs, ont toutefois grande l'importance dans l'orientation et la gestion de recherche hydrogéologique. Cette conclusion n'est évidemment valable que pour des compartiments bien délimités, dont les valeurs de transmissivité et de porosité efficace ne pourront être considérées comme des valeurs moyennes d'échantillons d'ordre de grandeur différent, mais comme des valeurs de distribution locales, qui nous renseignent à la fois sur la structure des champs de perméabilité, de potentiel hydraulique et de vitesse des écoulements dans la zone saturée du système aquifère (figure 4).

C'est pourquoi les lois hydrodynamiques des écoulements dans les aquifères karstiques, relatives à un niveau d'échelle générale restent inopérantes si on ne dépasse pas au niveau d'observation locale en des points directement accessibles.

Ainsi, on revient au problème d'échelle de la recherche dans les terrains karstiques, pour pouvoir décider à quel niveau d'échantillonnage les relations entre caractères physiques et les champs de leur distribution ainsi que l'anisotropie sont meilleur prononcées.

Références

- BORELLI, M. & PAVLIN, B. 1967 : Approach the problem of underground water leakage from the storage in karst regions. AIHS-UNESCO publ. No. 73. Vol. I, pp. 120-138, Actes du colloque de Dubrovnik.
- CASTANY, G. & MARGAT, J. 1977 : Dictionnaire français d'hydrogéologie. pp. 249, Bull. du BRGM, Orléans.
- DROGUE, C. 1980 : Essai d'identification d'un type de structure de magasins carbonatés, fissurés. Application à l'interprétation de certains aspects du fonctionnement hydrogéologique. Mém. h. sér. Soc. Géol. France, 11: pp. 101-108.
- GAO XU 1990 : Etude de certains caractères des zones saturées et non saturées de l'aquifère karstique. Thèse de doctorat, 142 p. Université Montpellier II.
- MIJATOVIC, B. 1970 : Method of studying hydrodynamic regime of karst aquifers by analysis of the discharge curve and level fluctuations during recession. Bull. Inst. Geol. and Geophys. Research, ser. B, No. 8, pp. 41-74, Belgrade.
- MIJATOVIC, B. 1980 : Effet d'échelle sur les paramètres hydrauliques dans le karst. 26^e Congrès Géologique International, 3 pages, No section 15, No d'ordre 0167, Paris.
- MIJATOVIC, B. 1984 : Captage par galerie dans un aquifère karstique de la côte Dalmate: Rimski Bunar, Trogir (Yougoslavie). Hydrogéologie des terrains karstiques - Des histoires des cas. AIH - IUGS - UNESCO, Volume 1, pp. 152-155, Heise, Hannover.
- PALOC, H. 1964 : Caractéristiques hydrogéologiques des dolomites de la région languedocienne. Mémoires du Centre d'Etudes et de Recherches Hydrogéologiques, Vol. 1, pp. 123-127, Montpellier.

Quelques réflexions sur l'effet d'échelle dans le milieu karstique montrent qu'il est étroitement lié à l'homogénéité du volume d'aquifère considéré. C'est à ce concept qu'il faut rattacher la critique contre l'opinion généralement admise pour les "valeurs moyennes" de la perméabilité ou transmissivité, et du coefficient d'emmagasinement, proclamées toujours comme les valeurs réduites (MIJATOVIC, 1980).

Nous voulons souligner que ces "valeurs moyennes", ainsi formulées, n'ont pas aucun sens et se trouvent mise en défaut par des expériences acquises dans la recherche

Les écoulements karstiques du polje de Ban Vieng, Laos central

par Claude Mouret (*) et François Brouquisse (**)

(*) La Tamanie, F-87 380 MAGNAC-BOURG

(**) 14, Cité Foch, F-65 000 TARBES

Abstract

Investigations in 1996 were conducted in the 17 X 7 km large polje. Water flows are transverse, due to the location of springs and sinkholes along the rim of the polje. During flood periods, the polje is commonly drowned, because of the too low absorption rate of the water-collecting caves, while emissive caves and a few ponors bring water in large quantities. The regional drainage is directed towards the Mekong River, which is located to the SW. Possible outlets of water from the polje are discussed within the framework of regional structures.

Le polje de Ban Vieng (PBV) est l'une des remarquables dépressions karstiques géantes du karst du Khammouane, long de 290 km au Laos et large de 35. Il est situé à 30 km au NE de Thakhek, une grosse ville au bord du Mékong, et orienté NW-SE. Sa taille est de 17 X 2 à 7 km (environ 70 km²). Il est prolongé par deux appendices principaux, l'un vers l'ouest (7 X 1 km), l'autre vers le S-SW (9 X 0,5 km).

Le polje est bordé sur presque tout son périmètre de pentes fortes et de falaises hautes de 200 à 500m. Un seul col permet l'accès en véhicule, au SE. De rares autres cols permettent le passage à pied. Les massifs qui l'entourent sont des karsts très rocheux, difficilement pénétrables. Quelques hums occupent sa partie plus large, au NW et au NE.

1.Contexte géologique

Le polje est creusé dans des roches paléozoïques. Les calcaires qui l'entourent et forment une grande partie de son substratum sont carbonifères, avec une possibilité de Permien Inférieur dans les parties les plus hautes de la série. Ces calcaires sont dolomitiques en proportion variable et interstratifiés avec des dolomies. Dans la partie sud-est du polje, des collines arrondies de quelques dizaines de mètres de haut sont attribuées à des séries argilo-gréseuses litées du Carbonifère inférieur, avec des bancs occasionnels de chert.

L'histoire géologique a été interprétée par FROMAGET (1927), PHAN CU TIEN (1990 et 1991) et MOURET (1994a et b). Une longue érosion, au Trias et au Lias, a suivi la sédimentation. Cette discordance, liée à l'orogénèse indosiniennne, représente dans le secteur une lacune stratigraphique de l'ordre de 60 millions d'années, mais la période d'érosion a été d'environ 20 à 30 millions d'années, chiffres réajustés à partir de nouvelles données sur l'orogénèse indosiniennne (MOURET, 1994b). Cette période a été favorable à la formation de paléokarsts, prouvés en d'autres points de la région (MOURET, 1994a). Une sédimentation Mésozoïque a suivi, essentiellement continentale et argilo-gréseuse, visible sur les reliefs qui bordent le karst au NE, et à Thakhek. Le Tertiaire a été une période de soulèvement lent et d'érosion, depuis environ 65 MA (MOURET, 1994b). La mise à l'air libre des carbonates est en fait relativement récente (Paléogène à Néogène) et se poursuit de nos jours, de façon centrifuge: cuesta du Mésozoïque au NE des calcaires.

Le polje est creusé principalement dans la direction des plis et ses appendices au SW perpendiculairement.

2.Contexte climatique

La pluviométrie sur le karst de Khammouane et ses alentours est connue pour 1991 (huit stations): 1800 à 2500 mm. Ces données sont imprécises pour les mois les plus secs. La station de Nakhon Phanom (NP de la carte) en Thaïlande mais proche, fournit des données sur 30 ans, voir tableau.

Le climat est tropical, avec deux saisons contrastées:

- une saison sèche d'octobre à avril, avec des précipitations mensuelles entre 1,2 et 105,2 mm en moyenne à NP,
- une saison des pluies de mai à octobre, avec à NP un pic en juin de 468,6 mm et 23 jours de pluie et un autre en août de 620,5 mm et 25,6 jours.

Les fortes pluies sont hétérogènes dans l'espace, comme en 1991 celles de juin ou du typhon du 18 août, qui a déversé en un jour ou moins 146,3 mm à Thakhek mais seulement 42,9 mm à Kamkeut (au NE du karst). Environ 140 à 160 mm, voire plus, sont tombés sur le karst en 24 heures au plus. Dans les chroniques annuelles de NP, on trouve des valeurs journalières de 459 mm en juin, 326 en août et 158 en septembre.

Les températures sont les plus élevées en avril: 28,8°C en moyenne mensuelle à 140 m d'altitude (NP), puis elles décroissent dès le début de l'augmentation de nébulosité et d'humidité associées à l'arrivée de la saison des pluies. Le minimum est de 22,0°C en décembre, pendant la saison sèche, -Koun Houai Fouang (k), vaste grotte à écoulement fond du polje commence à couler lors des crues avant les 4 puis l'augmentation progressive se fait plus rapide en mars.

L'évaporation mesurée sur surface libre à NP a son maximum de 167,1 mm/mois en avril (mois le plus chaud) et son minimum de 98,6 mm/mois en août (mois le plus humide: 86,8 %). L'évapotranspiration réelle calculée avec la formule approchée de TURC annuelle est de 1852 mm/an, soit 63% des précipitations.

3.Distribution des écoulements

Alimentation périphérique du polje

Plusieurs émergences ont été reconnues:

- Koun Houai Haeng (j de la carte), ensemble de 4 griffons impénétrables, temporaires, dans la dolomie à la base du versant. 50m plus à l'est, un petit ponor impénétrable sur le griffons. Le talweg peu marqué suggère un débit modéré.
- Koun Houai Fouang (k), vaste grotte à écoulement temporaire, se dirigeant vers l'ouest. Exploration commencée.
- Tham Koun Tcham Tcham (l). Grotte dans un éboulis

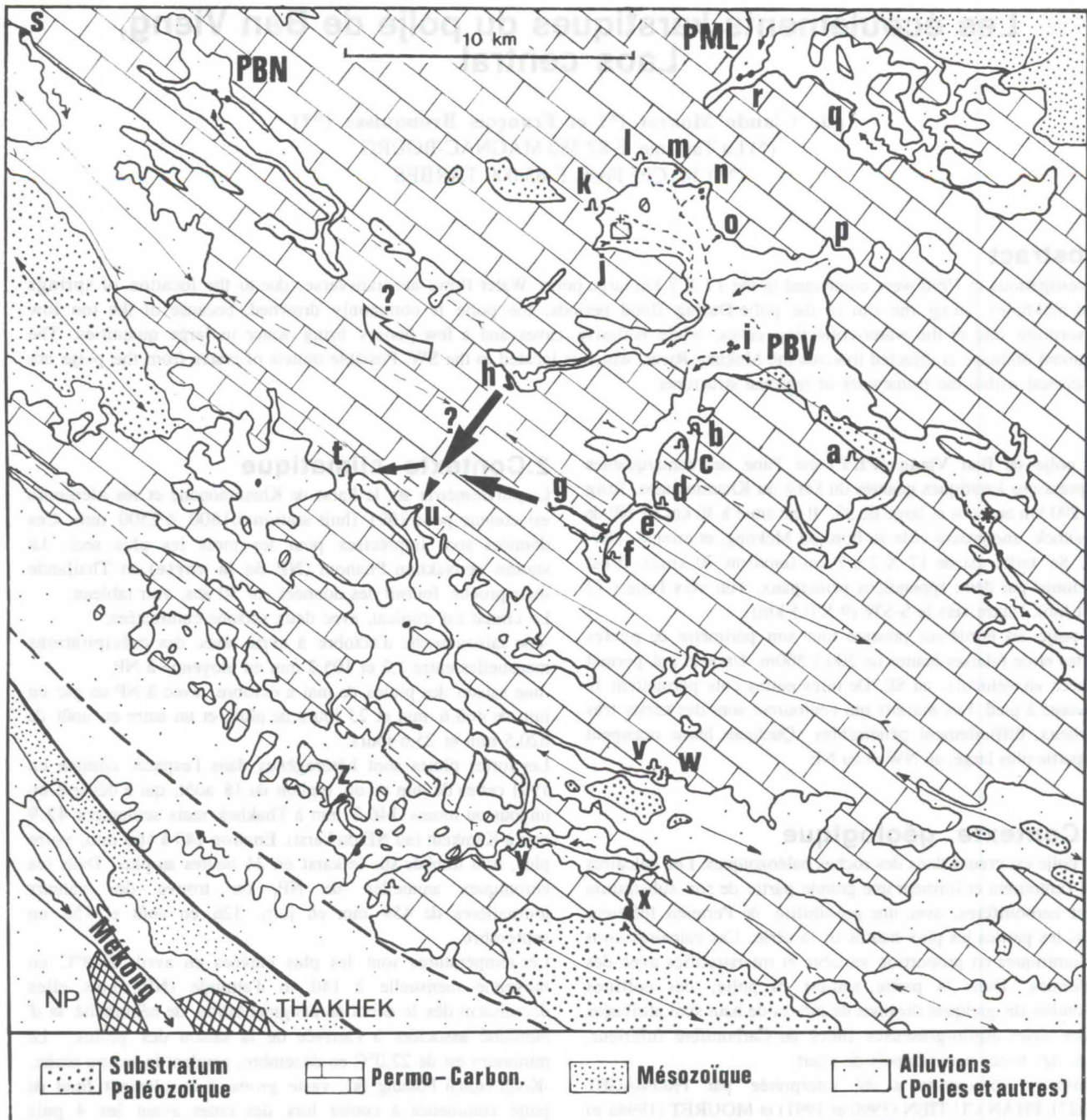

en pied de versant, au début d'un gros talweg temporaire. Environ 15m sous le fond du polje, il y a une galerie active: 3 à 5 l/sec le 8 mars 1996. Lors des crues, il y a mise en charge et un gros débit alimente le talweg (section mouillée d'environ 15m²). Deux autres sorties d'eau temporaires et impénétrables existent au pied du versant; la plus éloignée est à 50m.

-**Koun Nam Boh Phou Koh (m)**. Sortie d'eau entre des blocs sur le fond du polje près du versant. Débit quasi nul indiqué par un borbier. Puits artificiel voisin avec eau entre blocs.

-**Koun Ban Nat (Nam Hok Boh)(n)**. Sortie d'eau en fond de talweg (0,5 l/sec le 8 mars), à environ 300 m du versant; vasque de 7 à 8 m, peu profonde, sur fond de cailloutis. A une centaine de mètres plus au SE, sur le versant en pente faible du talweg (toujours dans le polje), un **orifice impénétrable** est le point d'origine d'une trainée de blocs à allure fraîche. L'ouverture de cette émergence est probablement récente et due à une sortie d'eau violente lors

des crues. Elle se développe vraisemblablement au détriment de la précédente.

-**Koun Nam Boh Anglin (o)**. Source sans grotte, pérenne, en pied de falaise (1 l/sec le 8 mars).

Koun Vang Kiet (p). Source pérenne du principal cours d'eau du polje.

Dans la branche ouest du polje et dans sa partie sud, plusieurs grottes donnent sur un plan d'eau calme qui s'élève lors des pluies et se déverse par l'entrée:

-**Tham Nam (c)**. Petite grotte descendante se terminant sur un lac.

-**Tham Hua Pakah (d)**, longue de 62m; le niveau monte de 4m lors des crues.

-**Grotte en pente (f)**, avec sable, menant à un lac. Dans son voisinage, une **galerie sur diaclase** vers le SE montre aussi une pente descendante, et pourrait mener vers un plan d'eau (P. BENOIT, comm. pers.).

- **Tham Louk Kouang (a)**: son lac à 35m de l'entrée monte de 2 m lors des crues.

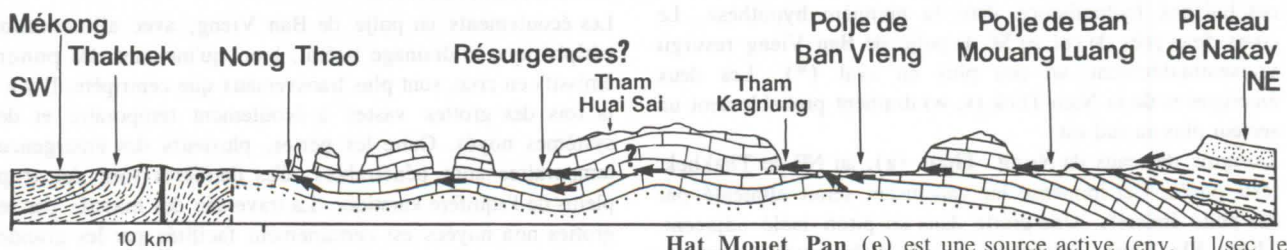

NAKHON PHANOM - MOYENNES ANNUELLES		
Altitude 140 m		
PLUIE (mm)	2293,9	
PLUIE (jours)	138,5	
HUMIDITE (%)	74,2	
TEMP.MIN. (°C)	21,0	1956-1985
TEMP.MOY. (°C)	25,9	
TEMP.MAX. (°C)	31,2	
TEMP.EXTR.MIN. (°C)	3,1 (janv.)	
TEMP.EXTR.MAX. (°C)	42,0 (avr.)	
INSOLATION (heures)	2431,3	1957-1985
EVAPORATION (mm)	1557,8	1981-1985
EVAPOTRANSPIRATION (mm)	1452	1956-1985

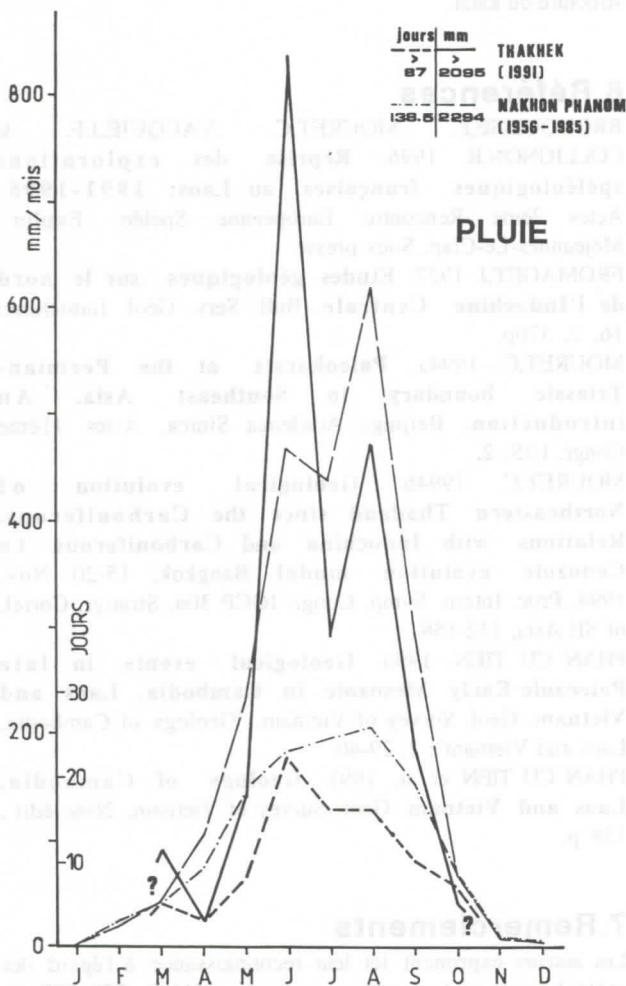

Hat Mouet Pan (e) est une source active (env. 1 l/sec le 4/3/96). L'eau traverse le polje et se perd à 300 m plus à l'ouest dans la falaise.

Alimentation centrale du polje

Trois lacs vaclusiens (i), sans écoulement le 9/3/96 découpent à l'emporte-pièce le fond du polje.

Pertes drainant le polje

Seules les deux principales semblent pénétrables:

-Tham Kagnung (h) est pérenne (env. 10 l/sec le 7/3/96). C'est une galerie de 10 X 10 m, avec des élargissements de dimensions doubles. La longueur connue est de 500 m.

-Tham Houai Sai (g) est temporaire. La galerie a peu d'affluents sur les plus de 2,5 km suivis; elle mesure 10 à 40 m de large et 5 à 40 m de haut. La pente est très faible, dans l'incertitude de la mesure (quelques mètres). Le sol est soit éboulés. Plusieurs lacs suspendus coupent la progression. A formé de graviers et de sable, avec présence de mégarides et de creusements en auge, indiquant des vitesses élevées, soit rocheux avec des marmites, soit recouvert d'énormes blocs 2,4 km de l'entrée, une petite arrivée d'eau forme un lac et se reperd. Un affluent coté est, près de l'entrée, draine aussi le polje.

Au SE du polje, un cours d'eau vers le col d'accès (*) se perd probablement.

Origine de l'eau arrivant dans le polje

Ces eaux ont deux origines: d'une part, les pertes de cours d'eau (q, r) descendant des massifs gréseux plus à l'est: plateau de Nakay; d'autre part, le drainage des massifs karstiques environnants. Le point de résurgence précis de chaque perte est pour l'instant inconnu, mais globalement il ne semble pas y avoir d'autre solution qu'une liaison entre ces pertes et certaines résurgences dans le polje. Koun Vang Kiet (p) est une candidate évidente pour ce rôle. Ces pertes alimentent aussi l'aquifère karstique noyé, en plus de l'infiltration directe au-dessus du massif karstique.

Destination des eaux du polje

La destination des eaux n'est pas encore fermement établie. La perte de Tham Houai Sai peut alimenter des résurgences (t, u) plus à l'ouest, vers l'aval hydraulique régional et dans le sens du pendage. La plus probable est (u). Les eaux de Tham Kagnung (h) peuvent soit suivre la même direction, en suivant les fractures NE-SW très visibles sur l'imagerie satellitaire, soit rejoindre le polje de Ban Nakh (PBN) plus au NW, en suivant un axe synclinal possible. Les eaux de

N°	Date	Lieu	T eau °C	pH	TH °f	TAC °f	HCO3 mg/l	Cl mg/l	SO4 mg/l	NO3 mg/l	Na mg/l	K mg/l	SiO2 mg/l	Cond. µS/cm
3	04.03.96	Sce de Hat Mouet Pan	[22.0]	7.54	19.5	17.1	209.0	1.3	1.7	0.22	0.39	0.23	5.0	321
4	05.03.96	Tham Louk Kouang	22.8	7.75	22.5	19.3	235.0	1.0	7.7	tr	0.75	0.51	10.0	355
5	08.03.96	Sce de Ban Tham Kuai	26.8	7.85	16.4	15.0	181.0	1.2	3.1	1.12	0.49	0.63	4.0	274
6	08.03.96	Sce de Koun Ban Nat	24.0	7.08	25.5	23.9	290.0	*	*	0.62	0.71	0.32	2.0	345
7	10.03.96	Tham Pla Sua	25.7	7.46	13.0	11.8	143.0	*	*	tr	0.33	0.22	16.5	203

Tham Houai Sai (g) se branchent peut-être sur la première de ces liaisons hydrauliques, dans la première hypothèse. Le cours d'eau près du col au SE du polje de Ban Vieng resurgit vraisemblablement un peu plus en aval (*). Les deux émergences de la Nam Thok (v, w) drainent probablement un secteur plus au sud-est.

L'origine des eaux du **Nong Thao (z)**, au NE de Thakhek, reste posée. Cet immense lac vaclusien serait alimenté par des puits émissifs. Une grotte dans un piton isolé adjacent, **Tham Pla Sua**, l'alimente aussi lors des crues, à partir de l'aquifère. Dans ce secteur barré hydrauliquement par les déformations le long de la faille de Thakhek, l'eau de l'aquifère provient nécessairement à la fois du NE et du SE, dans le secteur de **Tham En (x)**. Les trains de plis complexes peuvent offrir des points de passage pour les écoulements, notamment aux fermetures périclinales, en plus des nombreuses fractures NE-SW. Le toit de l'aquifère karstique est très peu penté, à l'instar des faibles pentes des vallées à l'échelle régionale (env. 50 cm/km).

Engorgement hydraulique du polje lors des crues: bilan entrées-sorties

Lors des crues, le polje s'envoie pour des durées variables. Ceci est dû au débit majoré de toutes les émergences/résurgences, à l'écoulement vers l'extérieur dans des cavités comme Tham Hua Pakah (d), Tham Koun Tcham Tcham (I), etc. et à la mise en charge et extravasement des ponors de Ban Louang (i).

Les pertes sont insuffisantes pour absorber tout le débit, à cause de leur nombre réduit et de leur pente faible. Une barque stationnée dans le polje (un peu au nord de (e)) suggère une tranche d'eau d'un mètre au moins sur de longues périodes. Vers les ponors de Ban Louang, l'inondation est identique; les récoltes, même de riz, sont souvent compromises lorsque l'elle se prolonge. Ce n'est que peu à peu que les écoulements par les pertes et l'évaporation assèchent le polje.

4. Composition chimique des eaux

Quatre analyses préliminaires ont été réalisées pour le polje et une près du Nong Thao. Les températures des sources varient entre 22.8 et 26.8 °C. Les valeurs les plus élevées correspondent à des débits faibles ou à des plans d'eau larges, et peuvent être influencées par la température de l'air. 22 à 24°C semblent mieux caractériser le karst local. Les pH sont neutres à basiques: 7.08 à 7.85.

Les eaux les plus minéralisées sont celles de l'émergence vaclusienne de Koun Ban Nat (n), du plan d'eau de Tham Louk Kouang (a) et de la source de Hat Mouet Pan (e). La source à débit très faible de **Ban Tham Kuai (+, près de k)**, peu chargée, draine la zone vadose d'un piton isolé.

L'interprétation des mesures de Tham Pla Sua est délicate. Ces eaux devraient être minéralisées, or elles le sont peu. Les mesures ont été réalisées hors de la période d'écoulement et comme le plan d'eau se trouve dans un piton isolé, peut-être l'eau phréatique pourrait avoir été diluée par des suintements d'origine vadose. Ceci suggérerait que le plan d'eau échantillonné soit suspendu au-dessus de l'aquifère. Toutefois ceci n'est pas confirmé par la silice. Ces problèmes sont à résoudre pour bien comprendre l'origine de ces eaux.

Les teneurs en silice, élevées pour des eaux karstiques, pourraient indiquer le degré de contact des eaux avec le substratum gréseux, dans la zone saturée. Les 10 mg/l de Tham Louk Kouang correspondent effectivement à sa proximité. Les eaux de Tham Pla Sua ont pu être en contact prolongé avec lui.

5. Conclusions

Les écoulements du polje de Ban Vieng, avec alimentation périphérique et drainage latéral, bien qu'incluant des ponors émissifs en crue, sont plus transversaux que centripète. Il y a à la fois des grottes vastes à écoulement temporaire et des systèmes noyés. Outre les pertes, plusieurs des émergences temporaires sont pénétrables. Ces dernières sont des trop-pleins de l'aquifère karstique. La traversée des massifs par les grottes non noyées est certainement facilitée par les grandes fractures NE-SW perpendiculaires aux équipotentielles régionales, qui peuvent permettre aux écoulements d'échapper aux contraintes structurales liées aux plis; jusqu'à quel point reste à préciser. Ces résultats préliminaires sont à affiner par des explorations nouvelles, qui permettront de mieux préciser la géométrie des écoulements. Elles inclueront nécessairement des plongées sous-aquatiques dans les systèmes noyés, notamment aux résurgences liées au barrage du karst près de la faille de Thakhek (Nong Thao) ou à des remontées sur des flancs d'anticlinaux (**Huai Namyen, s**). De nouvelles données chimiques devraient être acquises.

Ces résultats peuvent permettre de mieux lutter contre les crues dévastatrices de récoltes, en connaissant mieux la structure du karst.

6. Références

- BROUQUISSE, F., MOURET, C., VACQUIÉ, J.F. & COLLIGNON, B. 1996. **Reprise des explorations spéléologiques françaises au Laos: 1991-1996.** Actes 2ème Rencontre Européenne Spéléo. Explor., Méjeannes-Le-Clap. Sous presse
- FROMAGET, J. 1927. **Etudes géologiques sur le nord de l'Indochine Centrale.** Bull. Serv. Géol. Indochine: 16, 2, 370p.
- MOURET, C. 1994a. **Paleokarsts at the Permian-Triassic boundary in Southeast Asia. An introduction.** Beijing, Academia Sinica, Actes 11ème Congr. UIS: 2,
- MOURET, C. 1994b. **Geological evolution of Northeastern Thailand since the Carboniferous. Relations with Indochina and Carboniferous to Cenozoic evolution model.** Bangkok, 15-20 Nov. 1994, Proc. Intern. Symp. Congr. IGCP 306, Stratigr. Correl. of SE Asia, 132-158
- PHAN CU TIEN. 1990. **Geological events in late Paleozoic-Early Mesozoic in Cambodia, Laos and Vietnam.** Geol. Survey of Vietnam, "Geology of Cambodia, Laos and Vietnam": 2, 29-40
- PHAN CU TIEN et al. 1991. **Geology of Cambodia, Laos and Vietnam.** Geol. Survey of Vietnam, 2ème édit., 158 p.

7. Remerciements

Les auteurs expriment ici leur reconnaissance à l'égard des spéléologues qui les ont accompagnés: MM P. BENOIT, C. FERRON, H. FOUART, J. LORDON et J.F. VACQUIÉ. Rien n'aurait été possible sans nos amis du Laos, le regretté Claude VINCENT, qui nous avait accordé toute sa confiance, Mr Vannivong SOUMPHOLPHAKDY tout spécialement, et aussi MM LAI, KHAM et nos chauffeurs. Sans la bienveillance des autorités du pays, rien n'aurait été possible non plus. Nous tenons à exprimer ici notre démarche constructive et notre espoir que nos travaux soient utiles au Laos.

Hydrodynamic Behavior of a Karst Aquifer (Trnovski gozd Plateau, Slovenia)

by Barbara Reichert *, Heinz Hötzl * , Willibald Stichler ** & Peter Trimborn **
 * Department of Applied Geology, University of Karlsruhe, Kaiserstraße 12, 76128 Karlsruhe, Germany
 ** GSF-Institute for Hydrology, D-80764 Neuherberg, Germany

Abstract

Sustainable management of karst aquifers in respect to quality and quantity is only possible by a reasonable knowledge of the hydrodynamic behavior. Karst aquifers exhibit a great diversity of fast and slow flow components. Short residence times characterize the preferential flow in karst conduits, while the storage in the microfissured zones results in a relatively slow, and therefore much more retarded matrix flow component. Based on natural and artificial labeling combined with classical hydrogeological and hydrological investigations storage and discharge behavior of several karst springs discharging the Trnovski gozd plateau, SW Slovenia is defined.

1. Introduction

The knowledge and the quantification of the hydrodynamic processes of a karst system is essential for a sustainable management of these prolific groundwater resources. The great heterogeneity of karst environments is determined at the one hand by the external framework of the system, given by its geological and tectonical characteristics, and at the other hand by its internal structure such as the hierarchical organization of the flowpaths. The various karst processes, mainly the dissolution of the soluble rocks results in a complex net of pathways with variable spacing, aperture and length. Heterogeneity even starts in the recharge mode ranging from diffuse input over the whole outcrop to a predominantly point recharge in a small number of swallow holes. Flow and transport mechanism show great physical differences in the saturated zone as a result of the strong hydraulic discontinuities. Preferential flowpaths (interconnected conduits) have high velocities and short residence times. The almost unaltered rock matrix reacts as storage area, where fine fractures and matrix pores form the pathways and where water moves slowly and thus residence times is much longer. Compared to porous and fissured aquifers a rapidly modification of the initial characteristics of a karst aquifer results from ongoing solution processes.

In order to obtain sufficient information on a karst system several research methods are applicable (e.g. COST 1995). Our paper shows the possibilities of natural and artificial labeling combined with classical hydrogeological investigations to describe the storage and discharge behavior of a karst aquifer. Investigations were carried out in the Trnovski gozd plateau, SW Slovenia. Performed in the framework of the research of the International Association of Tracer Hydrology (ATH) (HABIC & KRANCJ 1997) our research was focused on the hydrodynamic behavior of the karst springs Hubelj, near the city Ajdovsina, Mrzlek, and Lijak near Nova Gorica.

2. Hydrogeological characterization

The well developed karst system of the karst plateau Trnovski gozd is characterized by an almost exclusively subsurface drainage system. It is drained by several huge karst springs. The whole system is strongly influenced by the geological structure and the fault pattern (Fig. 1). The tectonic repetition of mainly Mesozoic limestones and dolomites and Cretaceous to Tertiary flysch sediments of the nappe pile causes a characteristic alteration of permeable and impervious layers (Fig. 2). Due to strong vertical tectonics and lateral displacement of the nappe pile during and after the Alpidic thrust tectonics, hydraulic connections between the prolific limestone aquifers exist.

Preferable discharge conditions in NW-SE and N-S are predominant (Fig. 1).

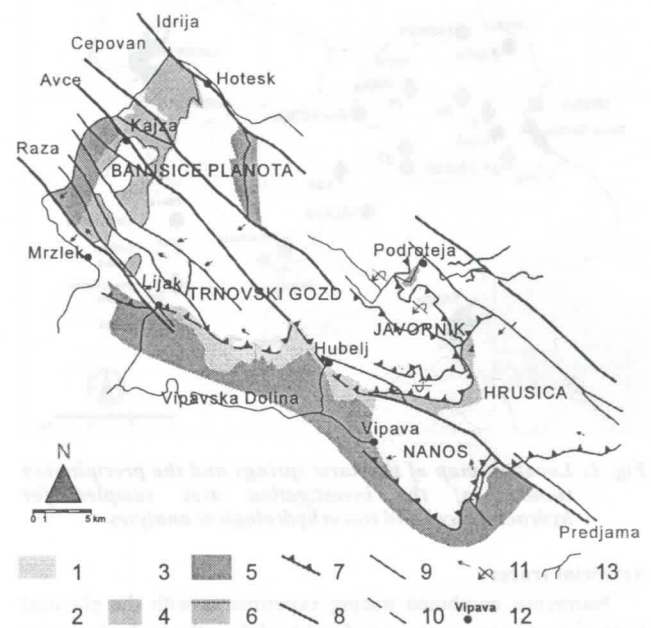

Fig. 1: Hydrogeological sketchmap of Trnovski gozd plateau, Slovenia, which forms the recharge area of various karst springs. (simplified after JANEZ 1996, STAHL 1994). [1 = porous aquifer (Quaternary slope debris); 2 = karst aquifer (Upper Triassic to Cretaceous limestones); 3 = fissured karstified aquifer (Triassic dolomites); 4 = impermeable aquiclude (flysch, Trnovo nappe); 5 = impermeable aquiclude (flysch, Hrusica nappe); 6 = erosional contact; 7 = overthrust; 8 = strike-slip fault; 9 = fault; 10 = fault supposed; 11 = strike and dip; 12 = karst spring; 13 = surface stream].

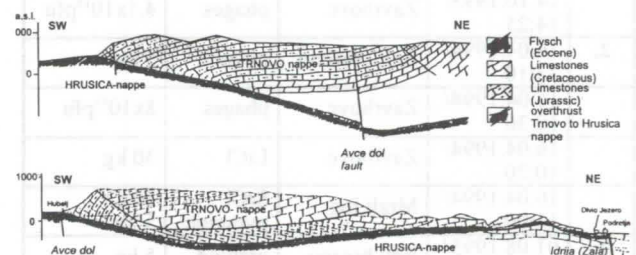

Fig. 2: Geological NW-SE profiles of the Trnovski gozd plateau (PLACER & CAR 1994), showing the overthrust of the hanging Trnovo nappe in form of a sheared SW-verging fold to the Eocene flysch of the Hrusica nappe.

3. Methodological approach

Environmental Isotopes

As a part of the water molecule the environmental isotope oxygen-18 (^{18}O) serves as an ideal tracer for the water flow. In addition to and in combination with other investigation methods ^{18}O provides reliable information on the mean altitude of catchment areas and on residence times and therefore on the storage capacities of a karst aquifer.

Precipitation as the input to the system was collected at six stations (Fig. 3), mostly in monthly intervals, partly diurnal for the evaluation of short term hydrological events. Water samples of the various karst springs (Fig. 3), the output of the system, were sampled at least once a week for the whole observation period. Although diurnal samples from selected springs are partly available. ^{18}O analyses were performed at the GSF Institute of Hydrology, Neuherberg. The $\delta^{18}\text{O}$ -values are given as relative ‰-deviation from the International standard water V-SMOW; the measuring accuracy (2σ) is equal to 0.1 ‰ in the $\delta^{18}\text{O}$ -scale.

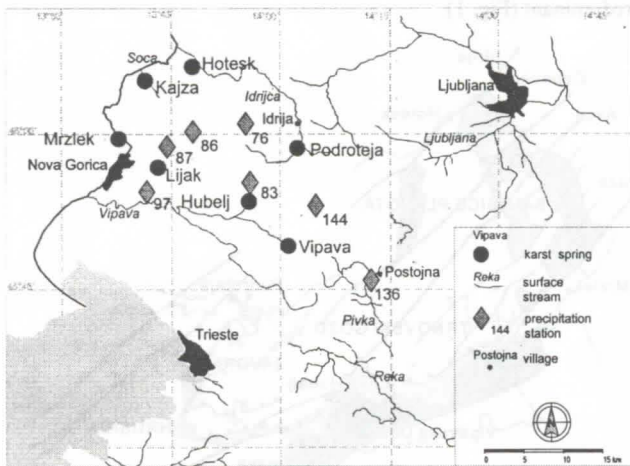

Fig. 3: Location map of the karst springs and the precipitation stations of the investigation area sampled for hydrochemical and tracerhydrological analyses.

Artificial tracers

Numerous combined tracing experiments with the classical hydrologic tracers were carried out to define the hydrodynamics of the fast components of the aquifer as well as to localize underground connections (HABIC & KRANCJ 1997). An overview of the tests performed is given in Tab. 1. Tracer-analyses were done in the usual way (details: HABIC & KRANCJ 1997).

Tab.1: Tracing experiments performed in the framework of the ATH-research project (Habic & Krancj 1997).

No.	Date /Time	Place	Tracer	Amount
1.	14.10.1993/ 13:10	Beli brezno	uranine	5 kg
	14.10.1993/ 14:25	Zavrhovc	phages	4.1×10^{15} pfu
2.	16.04.1994/ 13:10	Beli brezno	uranine	5 kg
	16.04.1994/ 10:30	Zavrhovc	phages	8×10^{15} pfu
	16.04.1994/ 10:20	Zavrhovc	LiCl	30 kg
3.	16.04.1994/ 11:00	Mrzli log	SrCl pyranine	50 kg 5 kg
	01.08.1995/ 11:37	Beli brezno	uranine	5 kg
	01.08.1995/ 10:34	Zavrhovc	phages	8×10^{15} pfu
	01.08.1995/ 10:35	Malo polje	pyranine	8.5 kg

Repeated tracing experiments were applied to define the variations of the fast component under different hydrologic conditions. As an example for the general flow behavior during the tracing tests the discharge of the Hubelj spring is shown in Fig. 4. The injection in autumn 1993 took place during very high karst water levels and multiple intensive precipitation events in the recharge area during the sampling period. In spring 1994 high, but compared to autumn 1993 lower, karst water levels and several rain events are characteristic. The injection in summer 1995 was carried out during prevailing baseflow conditions. Rain events starting 650 hours after the injection resulted in a remarkable increase of the discharge.

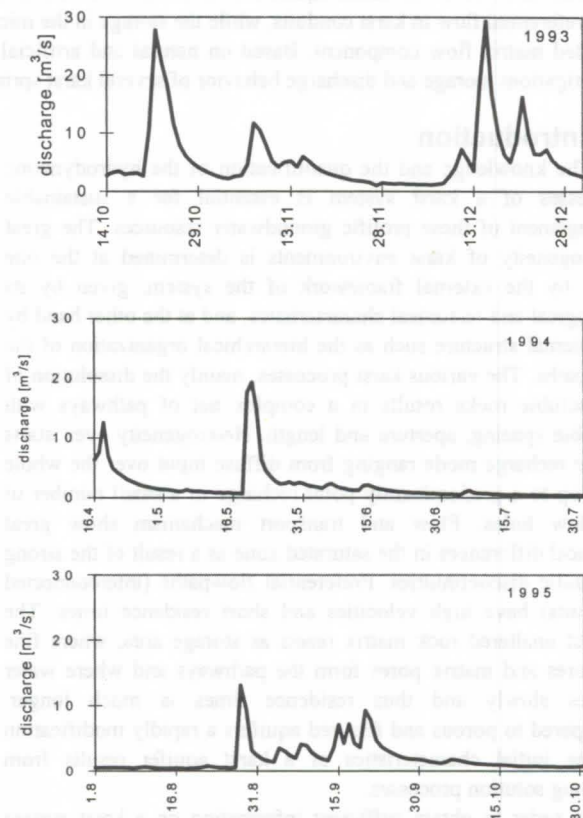

Fig. 4: Discharge behavior of the Hubelj during the tracing tests in autumn 1993, spring 1994 and summer 1995.

4. Results

Environmental Tracer

For the calculation of the altitude correlation in the karst plateau the weighted annual average of the $\delta^{18}\text{O}$ -values of all available precipitation stations (Fig. 3) was used (STICHLER et al. 1997). Fig. 5 shows, separately for each observation year, the correlation between the altitude of the station and the mean $\delta^{18}\text{O}$ -values. The resulting mean altitude effect for the complete observation time can be described by: $\delta^{18}\text{O} = -0.0024 h - 6.03$ (h = altitude in m a.s.l.).

All the karst springs investigated exhibit as expected the classical sinusoidal seasonal variations of the $\delta^{18}\text{O}$ -content (Fig. 6, Fig. 7), but the absolute values show a distinct difference according to the altitude of their catchment areas. Based on the above given mean altitude effect (Fig. 5) the mean altitudes of the catchment area for the springs Hubelj, Mrzleek, Kajza, Hotesk and Podroteja are calculated (Tab. 2) (STICHLER et al. 1997).

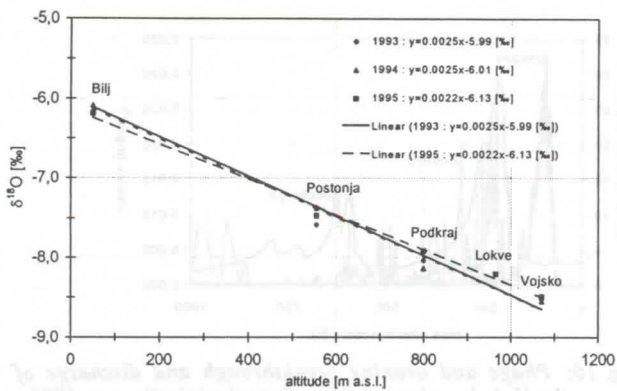

Fig. 5: Altitude effects calculated on the basis of the weighted mean $\delta^{18}\text{O}$ -values of the precipitation stations separately for each observation year.

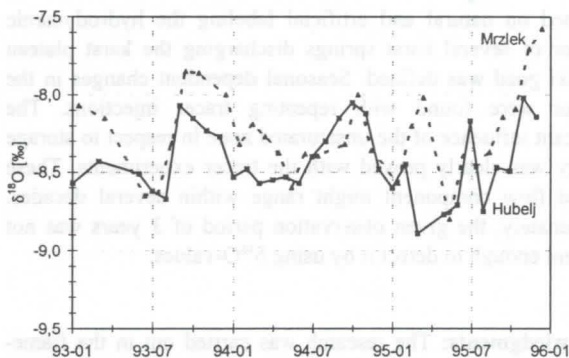

Fig. 6: Seasonal variations of $\delta^{18}\text{O}$ -content of the karst springs Mrzlek and Hubelj during the observation period from January 1993 to December 1995.

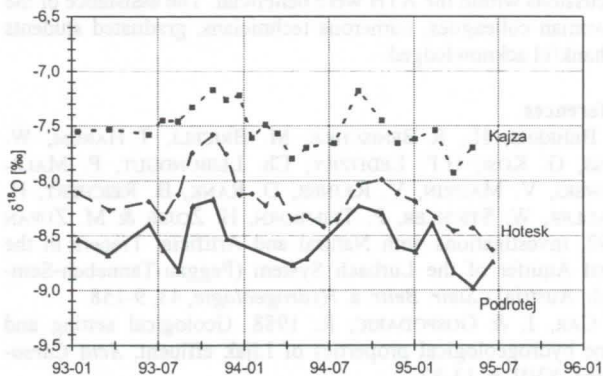

Fig. 7: Seasonal variations of $\delta^{18}\text{O}$ -contents of water of the karst springs Kajza, Hotesk and Podroteja during the observation period from January 1993 to June 1995.

Tab.2: Calculated mean altitude of the recharge areas of the karst springs Hotesk, Podroteja, Kajza, Hubelj and Mrzlek based on the mean altitude correlation (Fig. 5).

Spring	$\delta^{18}\text{O}$ [‰]	Altitude [m a.s.l.]
Kajza	-7.52 ± 0.20	620 ± 80
Hotesk	-8.18 ± 0.20	900 ± 100
Mrzlek	-8.24 ± 0.29	920 ± 120
Hubelj	-8.43 ± 0.23	$1,000 \pm 100$
Podroteja	-8.57 ± 0.24	$1,060 \pm 100$

For the estimation of the mean transit times in the karst plateau Trnovski gozd by means of the $\delta^{18}\text{O}$ -values the dispersion model (DM) was applied (STICHLER et al. 1997). Taking the given annual sinusoidal function of the isotopic curves for both the input (precipitation) and the output (springs) into account the transit times can be easily estimated by using the

amplitude ratio and the phase shift between the input and output iteratively. The mathematical background is given in detail in STICHLER et al. (1997). Based on the seasonal long-term variations (Fig. 6, 7) the calculations resulted in very short mean transit times of about five months for all springs (Tab. 3). For the direct runoff (with a portion of about 15 %) in the Hubelj travel times of one to two days were calculated, (STICHLER et al. 1997).

Tab.3: Calculated mean transit time (T) and dispersion parameter (P_D) of the springs (STICHLER et al 1997).

Spring	T [months]	P_D [-]
Kajza	5.4	0.28
Hotesk	5.5	0.30
Mrzlek	5.0	0.25
Hubelj	5.8	0.25
Podroteja	5.5	0.29

Considering the given hydrogeological conditions with catchment areas ranging from 60 to 80 km², aquifer thickness up to 700 m and unsaturated zones of about 400 to 600 m thickness the estimated residence times seem to be too low to characterize the flow component of the unsaturated zone and the microfissured rock matrix. This seems to be especially true in comparison to other karst systems such as the Lurbach system (BEHRENS et al. 1992), with calculated flow velocities in the range of 20 to 40 years in spite of a 10 times smaller recharge area. For a clear definition of these slow component which might range in several decades for the Trnovski gozd plateau, a much longer observation period is necessary.

Artificial Tracer

The tracing tests (Tab. 1) performed proved partly the main drainage system to NW-SE and N-S given by the structural geological pattern (Fig. 8).

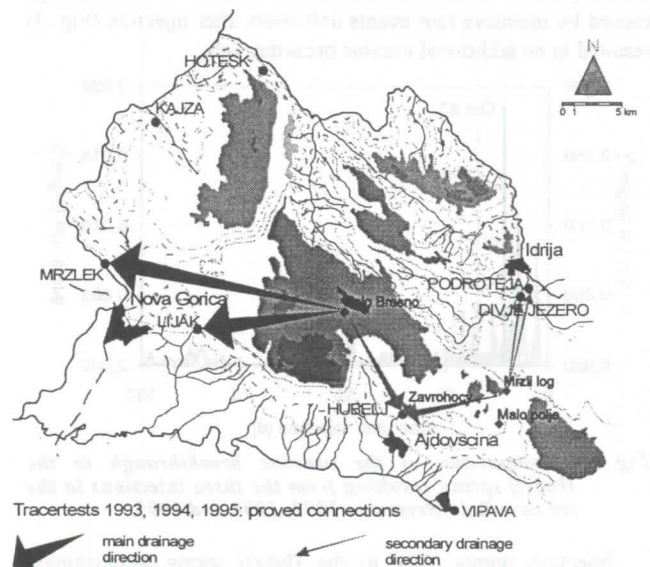

Fig. 8: Proved flow connections resulting from the tracing experiments in the years 1993 to 1995.

Following the general SW-dip of the limestone sequences and the S-dip of the overthrust plane, directed by the NW-SE striking strike slip faults, main reoccurrence of the tracers injected in the central part of the Trnovski gozd plateau (Belo Bresno) was the Mrzlek spring at the deepest regional base level. During all hydrologic situations tested Mrzlek was the main outlet (Fig. 9). During base flow conditions tracer breakthrough in Mrzlek spring started as a reaction of heavy rain falls in the recharge area 650 hours after the injection. The tracer was stored

in the about 600 m thick unsaturated zone till the infiltrating rain was able to transport it to the saturated zone. The resulting breakthrough curve shows features comparable to the former test. Caused by the flooding of the Mrzlek spring by the Soca river due to the construction of the Solkan hydroelectric plant, no discharge measurements are available and thus no calculation of the recovery rate is possible.

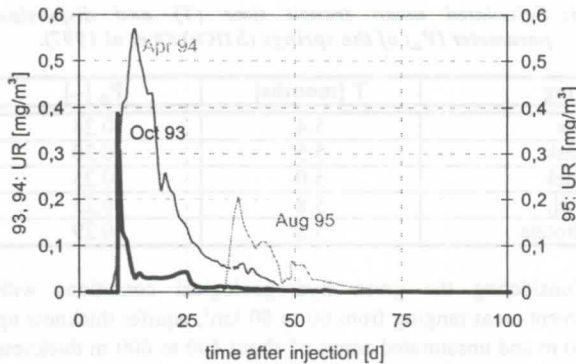

Fig. 9: Comparison of the uranine breakthrough in the Mrzlek spring resulting from the three injections in the ice cave Belo Bresno in 1993, 1994 and 1995.

Beside Mrzlek the periodical spring Lijak shows a significant uranine breakthrough in autumn 1993. Due to technical reason no sampling took place in spring 1994 and during base flow conditions Lijak was dry. CAR & GOSPODARIC 1988 postulated that Lijak reacts as an overflow spring of the Mrzlek, which was proved by the test 1993. The reaction pattern of the Hubelj spring was completely different (Fig. 10). The injection in the central part of the plateau, and although all injections in greater distances resulted in irregular tracer breakthrough. During base flow conditions (summer 1995) only singular peaks occurred. Contrary to the Mrzlek the remarkable increase of the discharge caused by intensive rain events 650 hours after injection (Fig. 3) resulted in no additional uranine breakthrough.

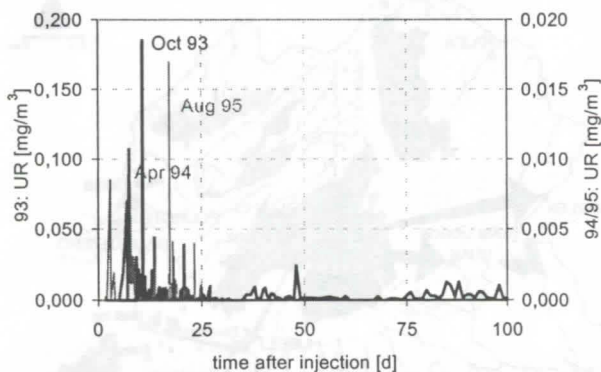

Fig. 10: Comparison of the uranine breakthrough in the Hubelj spring resulting from the three injections in the ice cave Belo Bresno in 1993, 1994 and 1995.

Injection points close to the Hubelj spring astonishingly proved a fast percolation of the about 600 m thick unsaturated zone of the karst aquifer (Fig. 10). Applying the dispersion model for the interpretation of the classical phage breakthrough curve result in a mean flow velocity of 20 m/h and a longitudinal dispersivity of 37.5 m for the sum of the vadose and phreatic flow distance. Despite the classical breakthrough, only a small tracer recovery of less than 1 % was found. Both, the irregular tracer recovery from all injection points in the plateau and independent from the hydrologic conditions as well as the small phage breakthrough resulting from a nearby injection place in the Hubelj manifested the importance of the up to 600 m thick unsaturated zone as storage area of the karst aquifer.

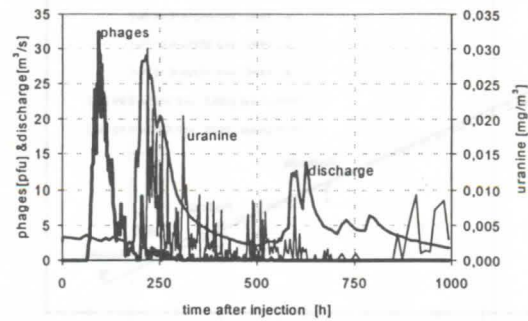

Fig. 10: Phage and uranine breakthrough and discharge of the Hubelj spring resulting from the injections in 1993.

5. Summary

Based on natural and artificial labeling the hydrodynamic behavior of several karst springs discharging the karst plateau Trnovski gozd was defined. Seasonal dependent changes in the behavior were found with repeating tracer injections. The significant influence of the unsaturated zone in respect to storage capacity was clearly proved with the tracer experiments. These retarded flow component might range within several decades. Unfortunately, the given observation period of 3 years was not sufficient enough to detect it by using $\delta^{18}\text{O}$ -values.

Acknowledgments: The research was carried out in the framework of a project of the International Association of Tracer Hydrology (ATH) under the chairmanship of the Slovenian Academy of Science, Karst Research Institute (Dr. P. Habic, Dr. A. Krancj). At the various stages during the investigations the discussions within the ATH were beneficial. The assistance of the Slovenian colleagues, numerous technicians, graduated students is thankful acknowledged.

References

- BEHRENS, H., R. BENISCHKE, M. BRICELI, T. HARUM, W. KÄSS, G. KOSI, H.P. LEDITZKY, Ch. LEIBUNDGUT, P. MALOSZEWski, V. MAURIN, V. RAJNER, D. RANK, B. REICHERT, H. STADLER, W. STICHLER, P. TRIMBORN, H. ZOJER & M. ZUPAN 1992, Investigations with Natural and Artificial Tracers in the Karst Aquifer of the Lurbach System (Peggau-Tanneben-Semriach, Austria).- *Steir. Beitr. z. Hydrogeologie*, 43, 9-158.
- CAR, J. & GOSPODARIC, R. 1988. Geological setting and some hydrogeological properties of Lijak effluent, *Acta Carsologica*, XVII, p. 13-32.
- COST Action 65, 1995. Karstgroundwater protection. Final report, *Europ. Commission*, Report EUR 16547 EN, 246 p;
- HABIC, P. & A. KRANCJ 1997. Karsthydrogeological investigations in SW-Slovenia, *Acta Carsologica*, XXVI, 300 p., (in press).
- JANEZ, J. 1997. Hydrogeology, in: HABIC, P. & A. KRANCJ 1997. Karsthydrogeological investigations in SW-Slovenia, *Acta Carsologica*, XXVI, 300 p. (in press).
- PLACER, L. & CAR, J. 1974. The hydrogeological problematic of the high karst between Idrijca and Vipava River (Trnovski gozd, Kriza gora and the plateau of Crni Vrh), *Acta Carsologica*, VI, p. 81-93.
- STAHL, W. 1994. Geologische und Hydrogeologische Untersuchungen im Einzugsgebiet der Hubelj-Quelle bei Ajodvscina/Slovenien. Unpubl. Master thesis, Applied Geology, University Karlsruhe, 101 p.
- STICHLER, W., TRIMBORN, P., MALOSZEWski, P., RANK, D., PAGESCH, W. & REICHERT, B., 1997. Environmental isotope investigations.- in: HABIC, P. & A. KRANCJ 1997. Karsthydrogeological investigations in SW-Slovenia, *Acta Carsologica*, XXVI, 300 p. (in press).

Structure tectonique et typologie karstique : cas des karsts de Vaucluse et de Port-Miou (région Provence - Alpes - côte d'Azur, SE de la France)

par Claude Rousset

Laboratoire de Chimie et Environnement, case 29, Université de Provence, 13331 Marseille Cédex 3, France

Abstract

By the way of the relations created between the different elements of the calcareous massive, the tectonical structuration plays a mayor part in the karstification process. So the karst typology is, at a given time of the geological story, closely linked to this heritage. Two examples taken in the SE of France, may emphasize such a differentiation. On the one hand, the karst of Vaucluse, grown into a thick limestone plate, moderately affected by tectonics along its borders, is a relatively simple holokarst with a well-developed drainage system. On the other hand, the Port-Miou karst is very more complex ; its annex-systems and terraced divisions carry on dominating ; this karst is not easily adjusting itself to a very multiphase tectonic framework, with many overthrusts, folds and faults. The very important differences in respect to the karstic typology are still present in spite of a more than 50 millions years old common geological and climatic story.

Résumé

Par les rapports qu'elle crée entre les éléments d'un massif de roches carbonatées, la structuration tectonique joue un rôle majeur dans le processus de karstification. A un instant donné de l'histoire régionale, la typologie du karst est donc très fortement dépendante de cet héritage.

Deux grands exemples illustrent cette différenciation dans une partie du SE de la France, pourtant soumise depuis plus de 5 millions d'années à des facteurs géodynamiques et climatiques communs. Le karst de Vaucluse, installé dans un panneau calcaire surtout tectonisé sur ses limites et de façon modérée, est un holokarst relativement simple à système de drainage bien développé. Le karst de Port-Miou, beaucoup plus complexe avec ses systèmes annexes et ses compartiments étagés encore dominants, s'adapte avec difficulté à un cadre tectonique polyphasé, très morcelé en début d'évolution par des écaillages et des chevauchements.

Les divers types de modélisation font d'autant plus avancer l'interprétation théorique du karst qu'ils sont basés sur l'observation naturaliste, qualitative et quantitative, et qu'un va-et-vient permanent s'établit entre terrain et modèle pour la validation de ce dernier. A vrai dire, certains chercheurs sont plus attirés par la démarche de terrain, d'autres par la modélisation et la perfection est approchée lorsqu'une collaboration s'établit entre ces deux populations.

Sur le terrain, les massifs karstifiables *str.s.*, uniquement ou de façon très majoritaire, constitués de roches carbonatées, présentent trois aspects que le naturaliste doit savoir appréhender : l'aspect litho-structural ou géologique, l'aspect morphogénétique et l'aspect hydrologique. Ces trois aspects sont étroitement liés et découlent l'un de l'autre dans l'ordre exposé. Il en résulte que la **typologie** du karst, classiquement basée sur les deux derniers aspects est sous la contrainte des données géologiques. C'est surtout l'histoire structurale qui guidera la morphogénèse superficielle et souterraine et l'organisation des circulations d'eau.

Paléo-contraintes et contraintes résiduelles ajoutent leurs effets pour déterminer la répartition des grands vides -donc, des drains et des zones de stockage des eaux - et des barrages. Les premiers s'organisent dans les parties en extension et les derniers, dans les aires en compression. Ces notions simplistes correspondent en fait à une complication singulière sur le terrain, quand l'on a affaire à des massifs karstifiés affectés par une tectonique polyphasée, ce qui est le cas habituel dans les régions touchées par le cycle orogénique alpin. Deux grands karsts du SE de la France, ceux de Vaucluse et de Port-Miou, me serviront à illustrer les différences qualitatives que peuvent induire des traits structuraux liés à une situation géodynamique partiellement différente.

1. Point de vue lithologique et structural

Jusqu'à l'intervention des phases de compression Sud-Nord pyrénéo-provençales (PP) (Crétacé supérieur à Eocène supérieur), les deux régions de Vaucluse et de Port-Miou voient leur destinée liée à celle du bassin du Sud-Est. Simplement, la seconde, située en zone haute au SE de la faille d'Aix-en-Provence, fonctionne plus tôt en plate-forme carbonatée. Mais au Barrémo-Bédoulien, cette unité orographique s'étend à l'ensemble, avec dépôt des calcaires urgoniens. Il est à noter que la bordure nord de l'aire vauclusienne correspond au linéament O-E du Mont-Lozère (ROUSSET, 1985) et que sa bordure ouest dépend du faisceau de la faille de Nîmes - ces accidents rejoignant dès le Crétacé inférieur au moins, sinon, comme les failles des Cévennes et d'Aix, dès le Lias.

Lors de l'apogée finale des phases PP, la couverture se décolle sur les niveaux évaporitiques du Trias. Un gradient de déformation décroissante s'établit nettement du Sud vers le Nord. Au Sud du *front nord-provençal* (ROUSSET, 1975 ; GUIEU & ROUSSET, 1980) se mettent en place de véritables nappes de couverture, avec chevauchements épiglyptiques et séries entraînées et des écaillages de socle. Dans une zone intermédiaire, on trouve des plis et des écaillages de couverture. Enfin, au Nord, l'écaillage du socle, sans déplacement tangentiel important, intervient jusqu'au Nord de la faille du Mont-Lozère, déterminant des déformations modérées de la couverture.

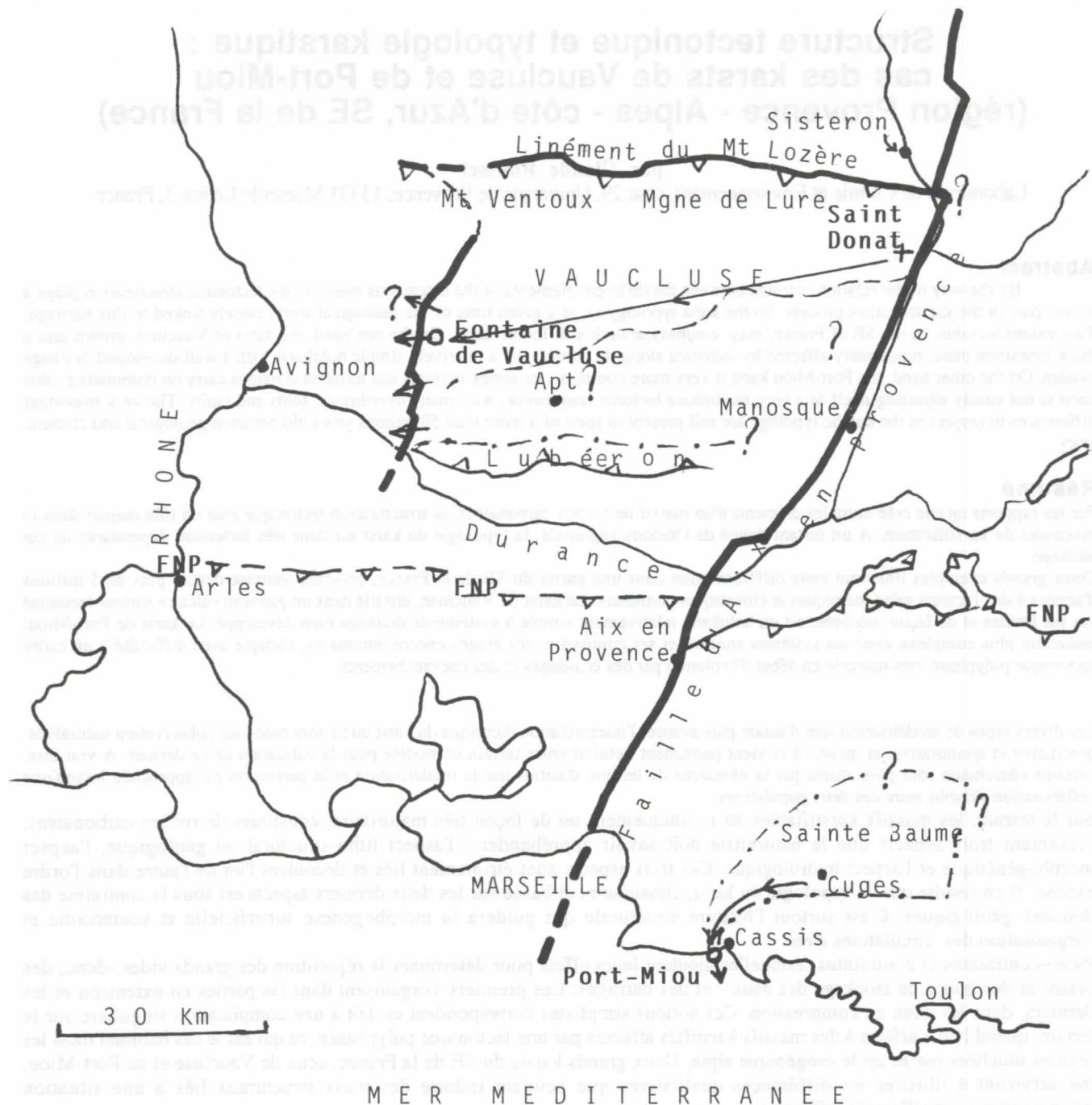

Figure : Carte schématique de la région étudiée

Pour le karst de Vaucluse, une limite en tireté est suggérée entre le massif calcaire Nord et les synformes d'Apt et de Manosque-Forcalquier ; les ? font allusion aux interrogations posées dans le texte ; le trait tireté-ponctué donne la limite Sud de l'ensemble calcaire susceptible d'être drainé par la Fontaine de Vaucluse en Lubéron ; le trait fin fléché représente l'axe de drainage vraisemblable, des trop-pleins de Saint-Donat à la Fontaine ; les flèches à l'Ouest montrent les sorties d'eau du karst. Pour le karst de Port-Miou, la zone d'émergence est unifiée, le trait tireté-ponctué donne une idée de l'extension de l'aquifère et le drain est représenté par un trait fléché en aval de Cuges. FNP : front des charriages de basse Provence ou Front Nord-Provençal sensu ROUSSET.

A l'Oligocène, la distension O-E, liée aux grabens ouest-européens, réactive les failles sub-méridiennes, entre les linéaments des Cévennes et d'Aix. Les fossés de cette direction interfèrent, à l'Est de la faille d'Aix, avec des bandes affaissées O-E liées à l'extension liguro commençante. Dans le premier lot, il faut placer le bord ouest du massif de Vaucluse, le fossé de Sault et les failles de Banon, la "fosse à sel" de Manosque et le bassin d'Aix-les Milles. La zone d'interférence correspond aux petits bassins de Marseille, Aubagne, St Zacharie et Bandol.

Enfin, les phases néo-alpines du Miocène créent une compression N-S à NE-SO qui engendre des déformations dont le gradient est naturellement inverse de celui des phases PP. La dalle de Vaucluse se ploie dans son axe, avec l'antiforme des Monts de Vaucluse et le synclinal d'Apt, mais surtout, chevauche au Sud dans le Lubéron et au Nord dans l'ensemble

Ventoux-Lure. Les failles sub-méridiennes héritées jouent et se complètent d'accidents conjugués (réseau de Daubrée). Au SE, de cette dalle, la couverture glisse vers le Sud le long de la faille d'Aix, créant les écaillés de Beaumont contre un segment transverse du linéament. Simultanément, l'aire sud-orientale - et notamment la région de Port-Miou - est affectée, à l'Est de la faille d'Aix, par des mouvements à dominante verticale qui surélèvent la plate-forme marine du Miocène supérieur, ménageant des zones de moindre soulèvement et, sans doute, des zones d'affaissement dans le Golfe du Lion. Les mouvements atteignent +1000m en Sainte Victoire et +400 (Sud), +700 (Nord) et +900m (Est) en Sainte Baume.

L'abaissement eustatique de la Méditerranée au Messinien se conjugue avec ces mouvements positifs pour une reprise d'érosion qui fait évoluer les reliefs vers leur état actuel. Deux remarques : le secteur SE, dont la région de Port-Miou, paraît moins affecté et il n'y existe pas de canyon comblé à terre - et rien ne prouve encore qu'un canyon messinien ait existé au droit de Fontaine de Vaucluse, le karst qu'elle draine paraissant bien isolé entre les rias pliocènes du Rhône et de la Durance.

2. Les deux karsts

Les massifs karstifiés de Vaucluse et du SE de Marseille sont surtout drainés par deux fortes exurgences : la Fontaine de Vaucluse et Port-Miou. Dans les deux cas existent cependant des émergences secondaires, de surface et sous-alluviales pour V, de surface et sous-marines pour PM. Dans les deux cas aussi, l'extension réelle de l'aquifère n'est pas encore parfaitement connue. A l'entrée comme à la sortie subsistent donc, dans les deux cas, des incertitudes malgré les acquisitions récentes (MUDRY, 1982 ; PUIG, 1987 ; COULIER, 1985 ; ROUSSET, 1988). Par contre, la typologie des deux karsts est bien connue.

Le karst de Vaucluse (BLAVOUX et al, 1992) comporte des drains bien évolués, à peu près disposés suivant son axe géographique, au Nord de la synforme d'Apt qui est une structure en compression sur plusieurs centaines de mètres d'épaisseur. Ces drains remontent jusqu'au bord est de l'unité aquifère, sur 70Km, avec un gradient inférieur à 0,3%. Le karst est établi dans une série de 500m environ de puissance, comprenant les calcaires de l'Aptien, du Barrémien et d'une partie de l'Hauterivien, au moins au Sud.

La fonction "stockage" est relativement peu développée et les systèmes annexes semblent discrets. D'ailleurs, la partie la plus active du karst comporte des avens profonds, montrant une bonne liaison entre la surface, des écoulements limités de zone II *sensu* CVIJIC et la nappe en réseau.

L'extension sur 70Km à l'Est de la Fontaine résulte de travaux récents sur les Sorgues de Saint Donat, près du val de Durance, qui s'avèrent des trop-pleins du système, liés à des pertes contribuant à son alimentation (ROUSSET, 1997). Dans le même secteur Est de Lure, les calcaires de l'aquifère constituent localement le lit de la Durance et de son affluent le Jabron. Une participation de ces rivières à l'alimentation du karst n'est pas à exclure au vu du terrain. Les arguments tenant à la géochimie des eaux que l'on oppose à l'éventualité de cette participation tiennent-ils assez compte de la dilution certainement importante?

Deux autres problèmes concernant l'extension du karst persistent : celui de la participation éventuelle de calcaires oligocènes (et miocènes ?) du bassin de Manosque-Apt et celui des relations, apparemment obligatoires, avec le flanc Nord du Lubéron. S'y ajoutent les incertitudes sur les débits diffusant vers d'autres aquifères, notamment alluviaux, à l'Ouest et au SO.

Outre les avens, nombreux et largement répartis, et les lapîès, de grandes formes caractéristiques : dolines, ouvalas, poljés fossiles... se rencontrent sur le karst de Vaucluse. Les cours des hautes vallées ne coulent qu'en saison humide et l'on rencontre de vraies vallées sèches.

Le karst de Port-Miou est pourvu d'un système drainant efficace dans sa partie aval, du bord ouest du *poljé* de Cuges jusqu'aux émergences. La principale, Port-miou, montre une galerie d'exhaure de 20m de diamètre ; comme celle du Bestouan, elle a été reconnue sur plusieurs Km en plongée. Les deux s'enfoncent graduellement en système vauclusien, la première gagnant en diamètre alors que la seconde s'achèverait sur des fissures impénétrables. D'autres sources secondaires existent sous la mer, jusqu'à environ -50m. Depuis le poljé de Cuges, le gradient hydraulique est de l'ordre de 0,6% - mais l'extension des drains n'est que d'une quinzaine de Km.

Le bassin-versant est limité dans sa partie aval à la zone des drains : à l'Ouest, le massif des calanques ne présente pas de nappe karstique et, à l'Est, les marnes superposées à l'Urgonien forment barrage hydraulique. En amont, il se développe par contre largement dans le massif de la Sainte Baume, suivant une typologie originale qui autorise des émergences secondaires parfois notables à partir de systèmes annexes bien développés. En outre, les barrages structuraux, parfois calcaire/calcaire, ont engendré des karsts étagés qui se déversent les uns dans les autres, jusqu'à la zone des drains. Ces barrages sont, suivant le cas, des contacts d'écaillés de série entraînée, le contact de base de la série charriée ou des failles d'extension tardives.

Ainsi, dans le ravin de Saint-Pons, une source munie de trop-pleins jaillit d'une écaille d'Urgonien en série renversée-entraînée ; les hydrogrammes sont caractéristiques d'un système annexe et le bilan fait apparaître un déficit au profit de drains profonds allant vers Port-Miou. 200m environ au Nord, des venues temporaires provenant d'ébouillements m'ont incité à installer un forage qui a pénétré dans l'Aptien sous-jacent à l'Urgonien de la source. Une nappe en charge y a été trouvée, sous 60m de marne imperméable et le débit emprunté au forage, généralement artésien, ne retient pas sur celui de la source. Quelle est la destinée normale de cette eau, à part les venues de saison humide par la faille-limite en extension ? Certainement Port-Miou, par des cheminements profonds qui rejoignent plus au Sud ceux de la source.

A la carrière Bronzo, c'est même un système annexe perché 70 à 80m au-dessus même des drains majeurs, qui a été atteint par forage. Il s'est développé dans la partie décomprimée d'une antiforme.

Les caractéristiques typologiques du karst de Port-Miou sont donc totalement opposées à celles du karst de Vaucluse. La fonction stockage y est très développée, fût-ce au profit d'écoulements sortant du système, grâce à la présence de systèmes annexes encore non recoupés par les drains. Ceux-ci présentent une pente deux fois plus forte qu'à Vaucluse et se développent beaucoup moins vers l'amont. Il faut ajouter que le karst est ici nettement moins pénétrable, les grands systèmes d'intérêt spéléologique étant localisés au NE, dans des zones structurellement plus simples. Les grandes figures de surface se limitent pratiquement ici au poljé de Cuges et à la cuvette de corrosion de Coulin, alignées sur des failles d'extension et sur le drain majeur du karst qui les suit de Cuges à Coulin. Le réseau des vallées sèches est peu dense.

3. Complexité structurale et complexité typologique

Les calcaires impliqués dans les deux karsts étudiés sont très proches du point de vue lithologique : ce sont des carbonates de plate-forme, de même âge, où les faciès de type urgonien, bio-détritique ou bio-construit, dominant. La paléogéographie originelle n'est donc pas sensiblement différente.

Les deux régions étudiées sont affectées, depuis la fin du Miocène, par des facteurs d'évolution similaires. A part la frange montagnarde, plus développée et plus élevée en ce qui concerne Vaucluse, l'on se trouve sous un climat tempéré méditerranéen que les phases froides du Quaternaire ont infléchi dans le même sens, sous l'influence du paléo-Mistral qui a fait avancer le pergélisol jusqu'à la basse vallée du Rhône. Lié à ces phases, le recul glacio-eustatique de la mer n'a pu que favoriser le surcreusement, le développement des drains, des karsts littoraux, tel Port-Miou. Or c'est en Vaucluse que cette évolution est la plus avancée, engendrant une typologie finalement plus simple.

La grande différence est donc dans la structuration tectonique, intervenue entre ces deux périodes de développement de caractères similaires.

On pense aussi au cas des Causses, auxquels le modèle simple de CVIJIC s'applique, sans faire appel à des notions plus modernes : holokarsts des Grands Causses - karsts perchés des Petits Causses des Cévennes. Les Causses ont, plus encore que Vaucluse, un passé structural simple et les puissantes séries carbonatées y sont relativement peu déformées.

C'est donc bien l'héritage structural qui est le plus contraignant pour l'évolution du karst. Il détermine d'abord les rapports entre roches carbonatées et roches imperméables ou moins perméables ; il y ajoute, au sein même des premières, les barrières des zones en compression, aux fractures obstinément fermées, donc non corrodables. Les rapports compliqués entre des unités très divisées défavorisent l'évolution morphologique typique de surface et de profondeur. Seules quelques structures majeures tardives, en extension, peuvent, par recoupement du cadre existant, donner naissance à des drains et à des formes spectaculaires. Mais dans l'intervalle entre ces structures, la complexité originelle prévaut, qui induit une conservation d'un type et d'un fonctionnement plus primitifs, favorables au stockage des eaux souterraines.

Références

- BLAVOUX, B, MUDRY, J. & PUIG, J.M. 1992. Rôle du contexte géologique et climatique dans la genèse et le fonctionnement du karst de Vaucluse. *Intern.Contrib. to Hydrogeology*, vol. 13, 115-131.
- COULIER, Ch. 1985. Hydrogéologie karstique de la Sainte Baume occidentale (Bouches du Rhône, Var). Thèse Doct.Spéc., Marseille, 399 p.
- GUIEU, G. & ROUSSET, C. La Provence. *Public. 26° Congr.Géol.Intern.* 65-80 et livret-guide.
- MUDRY, J. 1982. Etude du fonctionnement hydrodynamique de l'aquifère karstique de la Fontaine de Vaucluse (SE de la France) à partir des analyses physico-chimiques hebdomadaires. *Ann.Sci.Univ.Besançon*, mém. n° 1, 191-204.
- PUIG, J.M. 1987. Le système karstique de la Fontaine de Vaucluse. Thèse Doct.Spéc. Avignon, 208 p.
- ROUSSET, C. 1975. Apports de la méthode rétro-tectonique à la connaissance de la paléogéographie régionale : l'exemple des bauxites de Provence. *C.R.Acad.Sci.*, Paris, t 281, série D, 375-378.
- ROUSSET, C. 1985. Le cadre linéaire du Sud-Est de la France, à partir d'observations nouvelles sur son rôle dans la sédimentation tardi- et post-hercynienne. *Bull.Soc.Géol.Fr.*, (8), t. II, 487-497.
- ROUSSET, C. 1988. Apports de nouveaux forages à la connaissance de l'aquifère karstique de Port-Miou. Communes de Cuges et de Gèmenos, Bouches du Rhône, France. IV° Coll.Hydro.en pays calc., *Ann.Scientif.Univ.Besançon, Géol.*, Mém.h.s. n° 6.276-280.
- ROUSSET, C. 1996. Données nouvelles concernant l'extension de l'aquifère karstique de Vaucluse (France). Rés. Com. 16° R.S.T., éd. *Soc.Géol.Fr.*148.
- ROUSSET, C. 1997. Relations entre la limite Est du karst géant de Vaucluse et la faille-linéament d'Aix en Provence.(Région Provence-Alpes-Côte d'Azur, France). *C.R.Acad.Sci. Paris*, sous presse.

Approche de la structure et du fonctionnement d'un bassin hydrologique en pays calcaire : exemple du bassin du Suran, Jura méridional

par Abdelkader Sbai

Université Mohamed 1^{er}, Département de Géographie, Oujda, Maroc

Résumé

L'exploitation des aquifères karstiques nécessite une bonne connaissance de leur structure et de leur fonctionnement, ce qui passe par l'acquisition de nombreuses données (pluie, débit) et leur traitement. Dans cette note nous essayons d'approcher le comportement du bassin du Suran (Jura méridional) à partir de plusieurs types de traitements numériques, dont l'analyse des courbes de récession et l'analyse corrélatoire et spectrale.

Abstract

The karstic aquiferous exploitation necessitates a good knowledge of their structure and their functioning, this requires acquisition of many data (rainfall, discharge series) and their treatment. In this note we try to approach the behaviour of the basin of Suran (southern Jura) from several types of numerical treatments, among which recession curves analysis and autocorrelation and spectral analysis.

1. Introduction

L'hétérogénéité qui caractérise les systèmes karstiques et hydrologiques rend leur exploitation complexe. Celle-ci nécessite une excellente connaissance de la structure et du fonctionnement de ces aquifères pour limiter les risques d'échec et établir un mode d'exploitation approprié. Les investissements nécessaires à une telle approche peuvent être minimisés en faisant une étude préalable. Cette étude consiste en premier lieu à déterminer les réserves exploitables à partir de données existantes (pluie, débit) et à l'aide de moyens analytiques de mise en oeuvre aisée. Cette première étape débouche sur une classification des systèmes karstiques et hydrologiques qui conditionne les études complémentaires à envisager avant un éventuel aménagement.

2. Présentation du bassin du Suran

Le bassin du Suran (349 km² à Pont d'Ain) se situe dans le Revermont. Ses altitudes s'échelonnent de 600 m au nord de Loisia à 235 m à l'exutoire; l'altitude moyenne étant de 392 m. Il s'inscrit en majeure partie dans de puissantes séries calcaires et marneuses du Jurassique supérieur et du Crétacé inférieur. Ces séries sont plissées et faillées selon une direction NNE-SSW qui est celle du "faisceau plissé du Revermont". Dans le centre du bassin subsistent des dépôts fluvioglaciaires et glaciaires (Figure 1). Ce plateau entaillé par le Suran est le siège de phénomènes karstiques très développés. En surface, les formes karstiques sont représentées par des dolines et le poljé de Drom. En profondeur, il existe de multiples conduits dont les plus importants se développent dans l'axe même du synclinal du Suran. Ce sont là de véritables galeries larges de plusieurs mètres avec une hauteur de 0,5 à 0,8 m, qui suivent un tracé très voisin de celui de la rivière depuis Villereversure à l'amont jusqu'à Fromente à l'aval.

Le module du Suran pour la période 1973-74/1990-91 est de 6,36 m³/s à Pont d'Ain; 3,89 à Planche et 0,39 à Lasserra. Son régime hydrologique suit dans l'ensemble celui des pluies. L'étude de ses principales caractéristiques permet de le ranger parmi les bassins hydrologiques pluvio-niveaux, à tendance évaporale marquée (SBAI, 1992).

Signalons enfin que le Suran draine une nappe de fond de vallée qui intervient sur le comportement hydrologique de ce cours d'eau en augmentant son débit surtout en période pluvieuse.

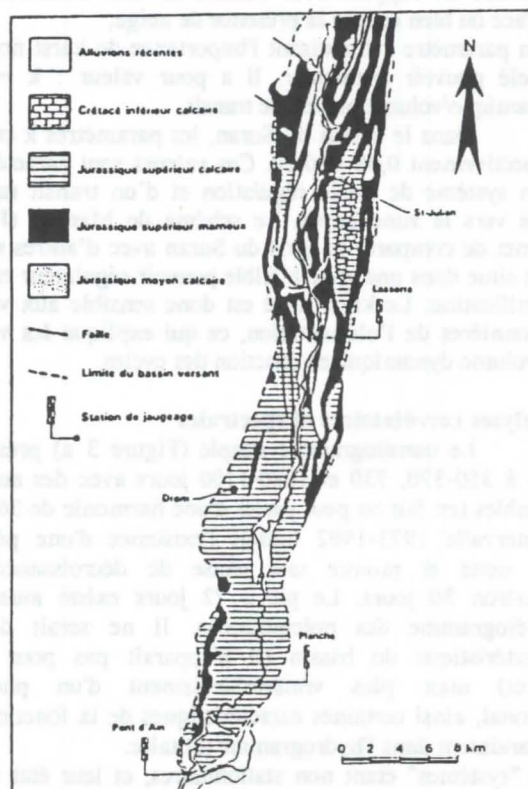

Figure 1 : Carte géologique du bassin du Suran

3. Moyens analytiques

Notre but est d'avoir le maximum d'information sur le fonctionnement et la structure du système à partir de la relation pluie-débit (données journalières); le fonctionnement est ensuite interprété en terme de structure. En plus de l'étude géologique nécessaire à la définition de la géométrie du réservoir et des limites de l'impluvium, deux types d'analyses sont employés :

- L'analyse des courbes de récession qui consiste à étudier la partie décroissante de l'hydrogramme de crue (SCHOELLER, 1962; DROGUE, 1967; MANGIN, 1970, 1975).
- L'analyse corrélatrice et spectrale (ACS) qui s'inscrit dans le cadre de l'approche systémique du karst. Elle repose sur l'utilisation du corrélogramme et du spectre (analyse simple), selon les méthodes appliquées au traitement des signaux; le système étant assimilé à un filtre qui module le signal d'entrée. L'étude du signal sortie (débits) fournit une indication sur la conservation, l'élimination ou la modification des informations fournies par le signal d'entrée (pluies). L'analyse entrée-sortie (analyse croisée) décrit la manière dont les informations d'entrée sont reproduites à la sortie (signature du système) (MANGIN, 1981 a, 1981 b, 1984).

4. Étude hydrogéologique

Analyse des courbes de récession (SBAI et al., 1994)

Nous avons travaillé avec les chroniques de la période 1973-1992. Les différents paramètres obtenus sont récapitulés dans le tableau 1.

Paramètres	Minimum	Moyenne	Maximum
coefficient de tarissement	0,0027	0,0307	0,0687
Volume dynamique (millions de m ³)	0,4080	6,7210	16,5000
Temps de la décrue (jours)	8	24	56

Tableau 1 : Paramètres de l'analyse des courbes de récession

La présence de réserves est confirmée par la valeur du volume dynamique qui varient entre 0,408 et 16,5 Mm³.

Pour reporter le système du Suran dans la classification de MANGIN (1975), deux paramètres ont été calculés à partir de l'analyse des courbes de récession:

* un paramètre *i* représentatif de l'infiltration et correspondant à la valeur prise par la fonction $Y(t)$ au bout d'un temps égal à 2 jours. Il caractérise la forme de l'hydrogramme de décrue et traduit les retards à l'infiltration sur les systèmes. Ceux-ci sont à mettre en rapport avec l'existence d'un ruissellement de surface ou bien encore la présence de neige;

* un paramètre *k* traduisant l'importance du karst noyé; il est appelé pouvoir régulateur. Il a pour valeur : $k = \text{volume dynamique} / \text{volume moyen de transit}$.

Dans le bassin du Suran, les paramètres *k* et *i* valent respectivement 0,08 et 0,24. Ces valeurs sont caractéristiques d'un système de faible régulation et d'un transit rapide des eaux vers la zone noyée. Le schéma de Mangin (Figure 2) permet de comparer le karst du Suran avec d'autres systèmes. Il se situe dans une zone à faible pouvoir régulateur et de forte karstification. Le karst noyé est donc sensible aux variations saisonnières de l'alimentation, ce qui explique les variations de volume dynamique en fonction des cycles.

Analyses corrélatrices et spectrales

Le corrélogramme simple (Figure 3 a) présente des pics à 350-370, 730 et 1080-1100 jours avec des amplitudes variables (en fait on peut parler d'une harmonie de 365 jours). L'intervalle 1973-1992 traduit l'existence d'une périodicité très nette et montre une phase de décroissance rapide d'environ 30 jours. Le pic à 72 jours existe aussi sur le corrélogramme des précipitations. Il ne serait donc pas caractéristique du bassin (il n'apparaît pas pour d'autres cycles) mais plus vraisemblablement d'un phénomène régional; ainsi certaines caractéristiques de la fonction entrée apparaissent dans l'hydrogramme unitaire.

Les "systèmes" étant non stationnaires, et leur état se modifiant au cours d'un épisode pluvieux sous l'effet de la succession des impulsions, on doit retrouver dans l'hydrogramme unitaire toutes les variations de l'entrée de périodicité inférieure à la durée de la réponse impulsionnelle (Mangin, 1981). En fait, les pics peuvent indiquer la conservation (en partie) de l'information entrée grâce aux drains à transit rapide.

Le spectre de densité de variance (Figure 3 b) présente un pic de forte amplitude pour les basses fréquences, correspondant à la période annuelle (357 jours). C'est la tendance saisonnière liée au cycle hydrologique. Un deuxième pic domine à 179 jours. D'autres pics mais de faible amplitude apparaissent à des périodes plus courtes : 86, 69, 52, 46, 40, 35, 28. Ces pics sont liés au signal d'entrée et correspondent en fait aux variations annuelles, à l'influence des

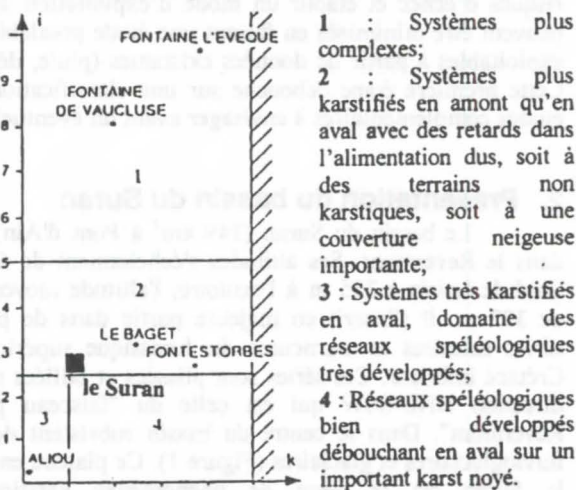

Figure 2: Position du système du Suran dans la classification de Mangin

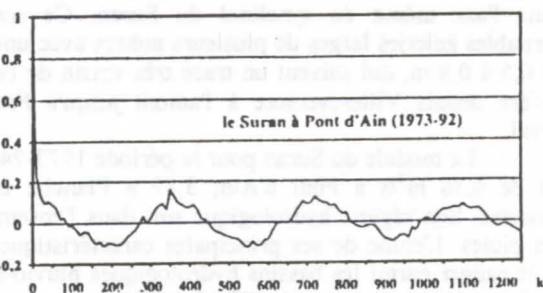

Figure 3a : Corrélogramme simple

périodes pluvieuses et aux variations saisonnières et mensuelles. Ils seraient donc à mettre en relation avec le spectre de la pluie pour la même période (Fig.3 b). Jusqu'à la fréquence de 0,2 (5 jours), tous les pics de fréquence contenus dans la pluie se retrouvent dans les débits. La fréquence de coupure est donc de 0,2.

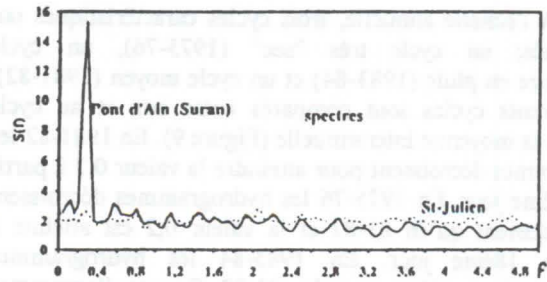

Figure 3b : Spectre des débits et des pluies

La fréquence de coupure du système du Suran à Pont d'Ain est de 0,176 (7 jours), l'effet mémoire est de 12-26 jours et le temps de régulation est de 9,13 jours.

Des impulsions brèves seront donc filtrées par ce système. Le pic à 0,028 (357 jours) apparaît sur le spectre (ainsi que sur celui des pluies) et traduit la variance saisonnière.

Ces remarques impliquent des réserves globales faibles, et une restitution de la fonction d'entrée presque sans modification et une réponse impulsionnelle de courte durée, traduisant une bonne organisation des écoulements. Le fonctionnement de ce bassin à alimentation variée est donc de type ruissellement de surface.

Le corrélogramme croisé pluie/débit (Fig.4), a une valeur maximale du coefficient de corrélation de 0,52. Il présente un pic très étroit et anguleux traduisant une réponse plus nette ce qui correspond aux résultats obtenus par l'analyse corrélatrice simple. Si l'on interprète les corrélogrammes croisés en termes d'hydrogrammes unitaires, ce cours d'eau présenterait des crues plus intenses et plus brèves.

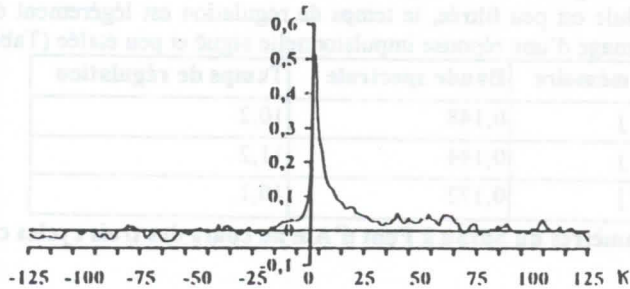
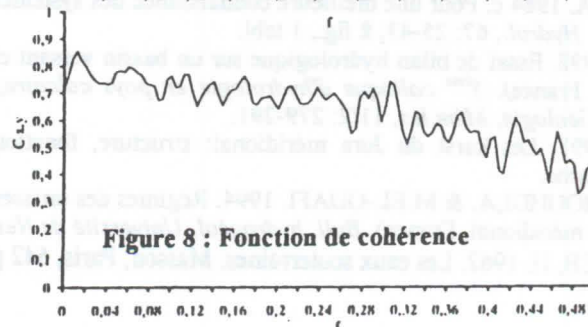
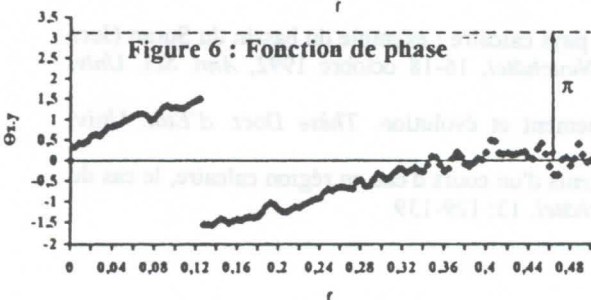
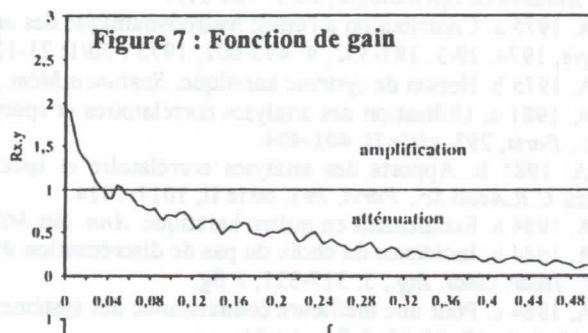
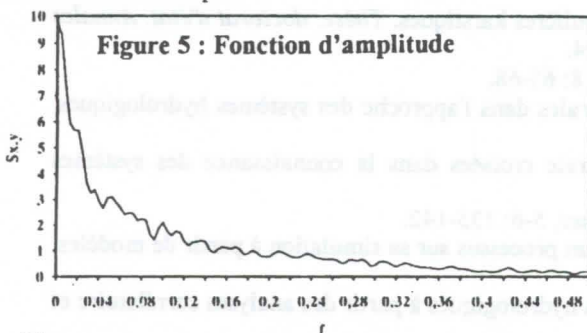

Figure 4 : Corrélogramme croisé

Les spectres croisés (Figures 5-8) fournissent différentes informations :

- La fonction d'amplitude (Figure 5) a un pic important à $F=0,08$ (125 jours), qui est présent aussi sur les spectres de pluie. On peut constater que pour les périodes inférieures à 6 jours environ (fréquence supérieure à 0,19), elle présente des valeurs négligeables. Autrement dit, ce système atténue considérablement les événements de courte période.
- La fonction de phase (Figure 6) indique un déphasage entre les événements de l'ordre de 2-3 jours, mais à prendre avec précaution puisque les cohérences sont moyennes. Même en tenant compte du temps de concentration, il existe un certain retard dans la propagation des impulsions d'entrée, donc dans l'infiltration.
- La fonction de gain (Figure 7) montre une faible amplification des très basses fréquences ($<0,016$: 63 j) et confirme la faible volume des réserves. Toujours dans le domaine inférieur à la fréquence de coupure, elle montre une atténuation rapide. Le pouvoir inertiel du système est assez important, ce qui indique des réserves globales non négligeables.
- La fonction de cohérence (Figure 8) présente des valeurs relativement constantes (de 0,6 à 0,7 pour les fréquences inférieures à la fréquence de coupure) montrant une bonne corrélation entre les événements d'entrée et de sortie (la linéarité du "système" est bonne, et les facteurs qui l'altèrent apparaissent sous forme de seuils). Ce système a un fonctionnement complexe.



A l'échelle annuelle, trois cycles caractéristiques ont été étudiés: un cycle très "sec" (1975-76), un cycle excédentaire en pluie (1983-84) et un cycle moyen (1981-82). Les différents cycles sont comparés entre eux et au cycle proche de la moyenne interannuelle (Figure 9). En 1981-82 les hydrogrammes décroissent pour atteindre la valeur 0,2 à partir du 19-29ème jour. En 1975-76 les hydrogrammes décroissent plus rapidement qu'en 81-82 et la valeur 0,2 est atteinte à partir du 18ème jour. En 1983-84 les hydrogrammes décroissent plus rapidement qu'en 81-82. Ces corrélogrammes montrent que ce système est peu inertielle et les réserves sont faibles. Il est de plus en plus inertielle de l'amont vers l'aval et les réserves plus importantes.

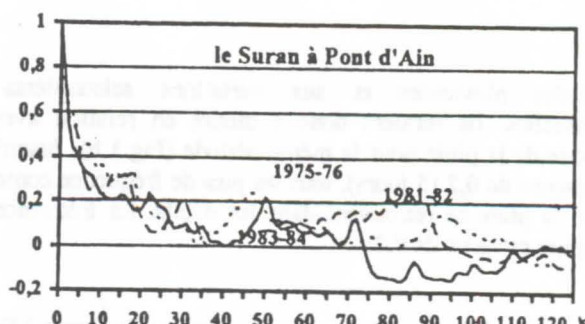

Figure 9 : Corrélogrammes de trois cycles caractéristiques

Par ailleurs, un système hydrologique voit son pouvoir régulateur augmenter de l'amont vers l'aval. Les pertes de charge s'accroissent et la mémoire des événements est de plus en plus importante et structurée (les réserves sont de plus en plus importantes). Cela donne un hydrogramme de plus en plus étalé de l'amont vers l'aval du système. Les temps de régulation (Tableau 2) définis à partir des spectres de variance semblent mieux répondre aux particularités des cycles et témoignent d'une organisation des écoulements d'autant meilleure que le cycle est excédentaire. L'information pluie est peu filtrée, le temps de régulation est légèrement élevé (10,1-11,2 jours). Le corrélogramme croisé fournit l'image d'une réponse impulsionnelle aiguë et peu étalée (Tableau 2).

	Effet mémoire	Bande spectrale	Temps de régulation
1976	18-21 j	0,148	10,2
1982	19-25 j	0,144	11,2
1984	13-27 j	0,172	10,1

Tableau 2. Paramètres du Suran à Pont d'Ain au cours des trois cycles caractéristiques

5. Conclusion

Les analyses corrélatrices et spectrales mettent en évidence les réactions du "système" par rapport à un signal d'entrée, apportant ainsi des renseignements sur son fonctionnement. Nous pouvons confirmer que ce système se caractérise par de faibles réserves, des structures de drainage bien développées et une réponse assez rapide aux impulsions d'entrée. Ces conclusions confirment celles issues de l'étude des courbes de récession, en les précisant. Ces méthodes ont l'avantage d'être facile à mettre en oeuvre et ne font pas intervenir la subjectivité des méthodes graphiques. Elles sont de plus favorables à un traitement de données importantes nécessaire à l'obtention de paramètres significatifs. Enfin, les ACS définies par les chroniques peuvent servir de base à une modélisation.

Références

- DROGUE, C. 1967. Essai de détermination des composantes de l'écoulement des sources karstiques. Evaluation de la capacité de rétention par chenaux et fissures. *Chronique d'hydrogéologie*, 10: 43-47.
- MANGIN, A. 1970. Contribution à l'étude des aquifères karstiques à partir de l'analyse des courbes de décrue et tarissement. *Annales de Spéléologie*, 25/3: 582-610.
- MANGIN, A. 1975 a. Contribution à l'étude hydrodynamique des aquifères karstiques. *Thèse. doctorat d'état. Annales de Spéléologie*, 1974, 29/3: 283-332; 4: 495-601; 1975 : 30/1: 21-124.
- MANGIN, A. 1975 b. Notion de système karstique. *Spelunca Mém.*, 8: 65-68.
- MANGIN, A. 1981 a. Utilisation des analyses corrélatrices et spectrales dans l'approche des systèmes hydrologiques. *C.R.Acad.Sc., Paris*, 293, série II, 401-404.
- MANGIN, A. 1981 b. Apports des analyses corrélatrice et spectrale croisées dans la connaissance des systèmes hydrologiques. *C.R.Acad.Sc., Paris*, 293, série II, 1011-1014.
- MANGIN, A. 1984 a. Ecoulement en milieu karstique. *Ann. des Mines*, 5-6: 135-142.
- MANGIN, A. 1984 b. Incidence du choix du pas de discrétisation d'un processus sur sa simulation à partir de modèles. *Bull. BRGM., Hydr. Géol. Ing.*, 3: 317-321, 2 fig.
- MANGIN, A. 1984 c. Pour une meilleure connaissance des systèmes hydrologiques à partir des analyses corrélatrice et spectrale. *J. Hydrol.*, 67: 25-43, 8 fig., 1 tabl.
- SBAI, A. 1992. Essai de bilan hydrologique sur un bassin versant en pays calcaire : exemple du bassin du Suran (Jura méridional, France). *5^{ème} colloque d'hydrologie en pays calcaire, Neuchâtel*, 16-18 octobre 1992, *Ann. Sci. Univ. Besançon, Géologie, Mém.h.s.*, 11/2: 279-291.
- SBAI, A. 1997. Les karst du Jura méridional: structure, fonctionnement et évolution. *Thèse Doct. d'Etat. Univ. d'Oujda. Maroc*.
- SBAI, A.; MOUHDI, A. & M.EL-OUAFI. 1994. Régimes des tarissements d'un cours d'eau en région calcaire, le cas du Suran (Jura méridional, France). *Bull. hydrogéol. Université de Neuchâtel*, 13: 129-139.
- SCHOELLER, H. 1962. Les eaux souterraines. Masson, Paris, 642 p.

Hydrogeology of glacial and subglacial karst aquifers: Small River, British Columbia, Canada

by Chris C. Smart

Department of Geography, University of Western Ontario, London, Ontario, N6A 5C2, Canada. SMART@SSCL.UWO.CA

Abstract

The Small River Glacier overlies two active conduit karst aquifers and has been studied to understand the nature of subglacial karst hydrology. Profoundly undersaturated surface meltwaters recharge the karst through moulines focused on the crest of large hummocks. Supraglacial traces reached karst springs faster than extraglacial waters, perhaps a result of paraglacial occlusion of sinks beyond the glacier margin. Glacier-karst flow routes were open channel and maintain very low (atmospheric) water pressures at the glacier bed. Variable divergence of replicate traces demonstrated that hydrogeographic divides were fuzzy and unstable. Divergence occurs through overflow and hydraulic switching rather than changes in the conduit. Subglacial flow followed a complex "submarginal" drainage system to the snout which gave highly anomalous hydraulic characteristics.

1. Introduction

Glaciated karst is a common feature of temperate and subalpine landscapes, but little is known about hydrological processes in karst beneath alpine and continental glaciers. Geomorphological evidence suggests that glaciers derange and infill karst (Ford 1979), but sites where karst springs emerge from glacierised catchments suggest active karstic recharge. Explorations in Castleguard Cave beneath the Columbia Icefield in Canada have demonstrated active subglacial hydrology, and this led Ford (1979) to suggest that high subglacial water pressures "stimulated" underlying karst by increasing hydraulic gradients. Unfortunately, this work has rested largely on the complex geomorphic aftermath of glaciation, and hydrological speculation. There have been only limited process studies of the hydrology and chemistry of the karst glacier bed.

Preliminary work on the Castleguard System revealed karstic capture and drainage of over 100 km² of the Columbia Icefield. Unfortunately, the massive scale and heavily crevassed character of the glacier prevented serious study, although dye tracing demonstrated karstic capture of glacier drainage (SMART 1983). As a result, research was started at Small River, British

Columbia, a site where a relatively small glacier overlies two hydrologically active karst aquifers (LOWE 1983). This paper provides an overview of hydrogeological research on Small River Glacier and subglacial karst aquifers.

Small River Glacier is a temperate alpine glacier of ~2.8km² located at 53°10'N, 119°29'W. The glacier lies on the southern flank of an east-west syncline and is underlain by two northward dipping carbonate units of the Cambrian Mural Formation, separated by ~120 m siltstone aquiclude (Figure 1), and sandwiched between quartzites and sandstones. The two aquifers discharge through respective North and South Springs which emerge from fault-guided conduits in the subalpine zone. These and other springs and up to six proglacial streams have been monitored for discharge, electrical conductivity temperature, hydrochemistry and turbidity over several summers from 1988. Water tracing has progressed from hydrogeographic mapping to high precision continuous monitoring of replicate traces (SMART & ZABO, this publication). Traces were run from extraglacial stream sinks both within and outside the Neoglacial limit, from supraglacial streams and from glacier boreholes.

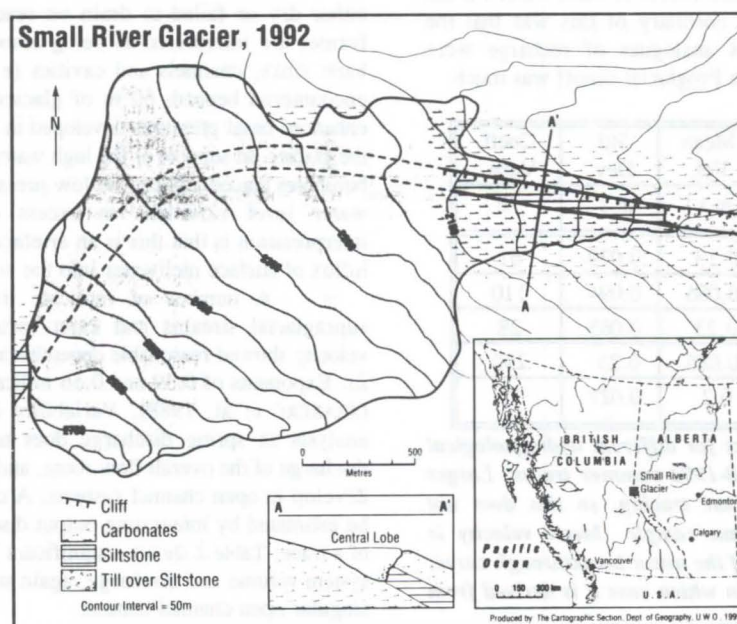

Figure 1. Small River Glacier hydrogeology. The major outlets, geology injection sites and drill area are shown.

2. Glacier karst hydrogeology

Diurnally varying discharge from the springs was sustained long after seasonal snow packs were gone. Simple water budgets demonstrated that aggregate discharge of sinking streams could not account for observed discharge and the glacier bed was the only reasonable recharge source within hydrogeological and topographic constraints. However, spring waters were much less turbid than proglacial streams and demonstrated less flow variability. Assuming that the highly volatile proglacial streams represent a glacier recharge analogue, a relatively diffuse karst aquifer was hypothesised. This was surprising as the massive limestone hosts extensive caves.

Water tracing (HUNTLEY 1990) demonstrated that the two carbonate units hosted independent aquifers. However, karst ground water velocities ($\sim 0.13 \pm 0.079 \text{ m s}^{-1}$, Table 1) around and beneath the glacier were comparable to surface stream velocities. This was taken to indicate a well-developed conduit aquifer, presumably incapable of filtering recharge waters. The remaining possibility was that the glacier bed was the site of water storage, retardation of recharge impulses and settling/filtration of fines. This might have arisen from an extensive soft bed, infilling of sink points or an extensive "distributed" basal drainage system (e.g., HOOKE 1989). Deglaciated carbonate surfaces preserve remnants of basal drainage channels (WALDER & HALLET, 1978). The carbonate surfaces at Small River are remarkably free of till. Many sinks in the glacier forefield were choked by till, but this is inferred to have been a paraglacial effect, largely occurring shortly after deglaciation (SMART 1994). Lee cavities characteristic of a distributed (linked cavity) system covered perhaps ten percent of the most hummocky terrain, although a number of entrenched Nye Channels linked into karst sinks, suggesting relatively free basal drainage. Recharge routed through a linked cavity system would result in damping and filtration of melt water. Quantitative tracing allowed this hypothesis to be tested.

On the glacier, surface melt water recharged the karst either directly through crevasses, or collected into supraglacial streams feeding moulins. Supraglacial streams were traced to karst springs, demonstrating extensive glacial recharge of the aquifer. However, rather than being slower than extraglacial traces, supraglacial-karst ground water velocities were considerably faster (Table 1), invalidating the notion that a linked cavity system was retarding flow. However, the traces revealed that the firn zone of the upper glacier was the dominant source of karst water for the stable-flowing South Spring. A corollary of this was that the proglacial streams identified as analogues of recharge were draining pure ablation zones. The Proglacial runoff was much

more "flashy" than streams responsible for karst recharge. Furthermore, most turbidity was found to be derived from extraglacial sources, especially a massive till derived from the siltstone aquiclude (Figure 1); firn and supraglacial meltwater contain little suspended sediment at Small River (LOCKREY 1996). It was concluded that the firn aquifer was responsible for damping the runoff response and sustaining flows.

Not only were supraglacial streams traced to karst springs faster than extraglacial karst traces, but they were also faster than traces to proglacial streams (Table 1). This may result from an absence of debris in subglacial sinks compared to those in proglacial areas. Furthermore, subglacial sinks often occur on the of bedrock hummocks and ridges, rather than in depressions which collect debris. This arises because the majority of moulins occur at the upper edge of crevasse clusters formed over $\sim 10 \text{ m}$ amplitude bedrock hummocks at the glacier bed. This means that moulins remain focused on the summit of upstanding features of the glacier bed, despite glacier motion. Such subglacial recharge has left many of the larger bedrock hummocks in the glacier forefield cut by Nye channels and karst sinks (HUNTLEY 1990). Subglacial recharge is therefore spatially incompatible with pre-existing closed depressions. Extending this idea, as glacier ice becomes thicker, only larger bedrock steps will induce crevassing. Under fuller glacial conditions the pattern of recharge will therefore shrink not only due to crevasse closure but also as the equilibrium line falls and local runoff is reduced.

In some cases, recharge penetrates directly into shafts, in others it follows the glacier bed down into closed depressions. Recharge shafts associated with crevasses have been observed in Castleguard Cave under $\sim 300 \text{ m}$ of glacier ice. The shafts generally pass directly through the cave passage to a lower level system. Sharply-etched, clean-washed bedrock suggest that recharge waters are highly corrosive and carry little suspended sediment. Supraglacial waters generally have very limited solutional capacity, although they are profoundly undersaturated with respect to calcite. This is not necessarily the case during early season snowmelt when enriched nival waters may be released (SHARP 1996).

What of water pressures at the karst glacier bed? The morphology of Nye channels indicates that they developed under open channel (low pressure) conditions. To tackle this question directly, a swath of glacier boreholes was drilled across a zone of karst sinks in 1989 and 1990 (SMART 1996). Most boreholes were either dry or failed to drain on reaching the glacier bed. The former are interpreted as being associated with freely draining karst sinks, channels and cavities (e.g. a 2 m high cavity was encountered beneath 60 m of glacier ice). The latter represent enhanced basal pressures developed in areas supporting the load of the glacier. In support of the high water pressure hypothesis, a few boreholes placed adjacent to low pressure areas displayed diurnal water level variations in excess of 80 m. Our current interpretation is that this is an artefact, the result of uncontrolled influx of surface meltwater into the borehole.

A number of replicate traces were made between supraglacial streams and karst springs. Tracer (straight-line) velocity showed reasonable dependence on spring discharge (Table 2). Exponents of 0.39 and 0.56 indicate open channel conditions (SEABERG et al. 1988). Variability is expected in this simple analysis as spring discharge does not adequately characterise discharge of the overall flow route, and considerable hysteresis can develop in open channel systems. A crude "system volume" can be estimated by integrating output discharge over the travel time of a trace. Table 2 shows a significant linear relationship between system volume and discharge, again supportive of the notion of a singular open channel conduit.

Several supraglacial traces travelled to both karst and

Hydrogeological Environment		n	Mean Vel. m s ⁻¹	Std. Dev. m s ⁻¹	Coeff. Varn. %
Input	Output				
Extragl.	Karst	12	0.13	0.079	61
Supragl.	Progl.	13	0.086	0.094	110
Supragl.	Karst	26	0.23	0.065	28
Subgl.	Progl.	11	0.085	0.25	290
Subgl.	Karst	3	0.2	0.027	13

Table 1. Tracer velocity statistics for different hydrogeological environments derived from 1988-1992 summer traces. Larger sample sizes result from replicate tracing, so this does not constitute a random independent sample. Mean velocity is generally derived from centroid of the tracer breakthrough curve, unless the curve is ill-defined, in which case it is derived from time to peak concentration.

proglacial outlets, but this divergence was inconsistent, implying “fuzzy” (inexact) and unstable (variable in time) divides. P.L.SMART (1977) suggested that “fuzzy”(inexact) divides should be drawn using recovery weighting to determine an imaginary line delineating 50–50 partitioning of tracer. However, this does not help with the unstable divides found in this case. Instead a graphical procedure for presenting such complex data has been developed, in which a rectangle is positioned at each injection site and is subdivided into a number of horizontal bars to represent each trace. The bars are shaded to represent the outlet to which they are routed. Divides can simply be drawn between the rectangles. Divergent traces are represented by subdividing the shading on the relevant trace bar in proportion to the relative recovery of tracers. Inconsistently shaded rectangles highlight zones of inherent instability.

Hydraulic conditions for replicate traces are ill-controlled, but there is a crude association of divergence with higher discharge, implying a simple overflow mechanism. Instability may also result from the inherent instability of glacier drainage systems; conduits are subject not only to thermal erosion, but closure due to creep and sliding. Consideration of glacier hydrology can help resolve this question.

3. Glacier hydrogeology

Proglacial data are not quite so readily obtained as spring data, stage and the channel are highly volatile, leading to equipment failure, water can be very turbid and defining “velocity” for highly dispersed (and often multi-peaked) breakthrough curves can be very difficult. Nevertheless, traces to proglacial streams were consistently slower, but much more varied than karst traces (Table 1). Surprisingly, the average velocities are almost identical for borehole and supraglacial traces, and both show extremely high coefficients of variation. It was expected that supraglacial streams would be connected to low resistance conduits and therefore much faster and less varied than borehole traces. Boreholes might be expected to feature a higher fraction of “unsuccessful traces” because of their random placement, and the finite coverage of the basal drainage system. However, borehole injections are normally preceded by five minutes of water injection to determine if a borehole is “connected”, and followed by thirty minutes of flushing in an attempt to drive the tracer into the local drainage system.

The velocity data might imply that a spatially consistent mix of distributed and conduit drainage was being equally exploited by supraglacial and borehole traces. However, most of the supraglacial traces were replicates which means that the hydraulic character of the flow route was changing radically as discharge varied. The exponents of the velocity–discharge for supraglacial–proglacial traces (Table 2) are considerably greater than one. Under any coherent system of hydraulic geometry, the maximum value for the exponent b is unity, obtained in a closed pressure conduit (SEABERG ET AL. 1988). Was it possible that the basal conduit was changing in size in response to discharge and water pressure? Under thin ice, maximum water pressures are too low and creep closure too slow. Overall head of <200 m and subglacial discharges of $< 0.1 \text{ m}^3\text{s}^{-1}$ do not release enough potential energy to enlarge the conduit significantly by frictional dissipation.

A related anomalous result is that the system volume coefficient is negative (Table 2). This implies that the flow route volume is *smaller* at higher discharge, which is contrary to any conceivable hydraulic adjustment. Table 2 also reveals that the characteristics of Old Drill and Propane traces (plus traces from neighbouring sinks) are quite distinct. These traces are following different routes; Propane traces are faster, accelerate relatively little with discharge and have a smaller system volume than Old Drill traces. Our interpretation is that as discharge increases, water levels within the glacier rise to activate more open and direct high level overflow routes. The lower level flow routes followed by Old Drill traces at low discharge have a minimum observed volume of $\sim 30,000 \text{ m}^3$, equivalent to an unreasonable cross-sectional area of 46 m^2 . This high figure arises because the integration of discharge at the snout includes water following the fast overflow route. Subtracting the Propane Stream system volume drops the Old Drill volume to $\sim 20,000 \text{ m}^3$. Additional overflows would further reduce the volume. Nevertheless, the “equivalent pipe” would still average a few metres in diameter, and require impossibly large friction factor. The simplest means of maintaining a high volume high friction system is through alternating numerous resistive constrictions with large open volumes. These are exactly the hydraulic characteristics of a linked cavity system (e.g. Hooke 1989).

The glacial drainage system at Small River has been termed “submarginal” and consists of a deep distributed system

Flow Route		Velocity = aQ^b					Volume = $c + dQ$			
Velocity (m s^{-1}) or Volume (m^3s^{-1})	Discharge at Q ($\text{m}^3 \text{s}^{-1}$)	n	a	b	r	Signif @95%	c	d	r	Signif @95%
Propane Supraglacial Stream	South Spring	8	0.26	0.39	.63	~ No	3800	6100	0.78	Yes
Icefall Pond Supraglacial Stream	South Spring	11	0.21	0.56	.92	Yes	8200	6500	0.94	Yes
Old Drill Supraglacial Stream	Central Proglacial Stream	5	0.12	2.8	.91	Yes	57300	-67400	-0.98	Yes
Propane Supraglacial Stream	Central Proglacial Stream	3	0.27	1.5	0.97	~ No	9100	-5500	-0.96	~ No

Table 2. Replicate supraglacial traces to South Spring and to Central Proglacial Stream. Coefficients and exponents for the relationship $V = aQ^b$, correlation coefficient (r), sample size (n), and results of a statistical test of $r=0$ at the 95% confidence level. Constant c and coefficient (d) and test of the linear relationship between “system volume” and discharge.

grading up towards the glacier margin into an efficient conduit system. Marginal channels are envisaged as cutting down "dip" across the longitudinal grain of the system. These serve to equalise head across segments of the system resulting in lower velocities in the deep system under high discharge.

Tracer divergence at Small River does not seem to result from short-term changes in the geometry of conduits. Rather, it arises from discharge-dependent routing effects in a complex heterogeneous drainage network.

4. Conclusions

Under thin (< ~300 m), temperate alpine glaciers surface meltwater reaches the bed through tectonic crevasses and moulins. Despite low summer solution capacity, the water penetrates into underlying carbonates to link into karst drainage systems. At Small River, subglacial karst drainage is faster than proglacial drainage which appears to suffer from paraglacial disruption. Basal water pressures are low on karst glacier beds and open channel flow dominates in active subglacial karst. Subglacial "stimulation" of karst does not appear to result from enhancement of water pressures. It is more likely a combination of the absence of sediment and profoundly undersaturated waters reaching debris-free areas of the bed. Divides at the glacier-karst interface are fuzzy and unstable, largely the result of hydraulic switching from a low level distributed system to efficient high level overflows. Unsteady flow effects may not be uncommon in conventional karst tracing, but they require high precision replicate tracing to be discriminated.

Active karst might be expected to have some impact on overlying glaciers. First, sustained low pressures will substantially retard glacier sliding. In addition, free drainage will result in substantial loss of heat energy from the bed, and will probably prevent development of the integrated conduit system normally developing in areas of intensive recharge. Finally, high solute loads in basal regelation waters might be expected to significantly retard regelation sliding. Glaciers on karst might well be expected not only to discharge less water, but also to move more slowly, become steeper and perhaps advance less than conventional neighbours.

Although a great deal has been learned about subglacial karst from Castleguard and Small River, these results have limited applicability to continental glaciation where great thicknesses of cold ice overlie the karst.

Acknowledgments

Field and laboratory work reported here has been generously funded by the Natural Sciences and Engineering Research Council of Canada, and the University of Western

Ontario. Numerous students have worked on the tracer and hydrogeological work, in particular thanks go to D.Huntley, R. Rogalski, K.Carr and L.Zabo.

References

- FORD, D.C., 1979 The impact of glaciation on karst aquifers. *Journal of Hydrology*
- HOOKE, R. Le B., 1989.Englacial and subglacial hydrology: a qualitative review. *Arctic and Alpine Research* 21 221-233.
- HUNTLEY, D.H., 1990.*Hydrogeomorphology of an alpine karst*. Unpublished MSc Thesis, University of Western Ontario.
- LOCKREY, D.A., 1996.*Suspended sediment variations in a glaciated alpine catchment*. Unpublished MSc Thesis, University of Western Ontario.
- LOWE, D.J., 1983.The Anglo-Canadian Rocky Mountain speleological expedition, 1983. *Transactions of the British Cave Research Association* 10 213-244.
- SEABERG, S.Z., SEABERG, J.Z., HOOKE, R. Le B., & WIBERG, D.W., 1988. Characteristics of the englacial and subglacial drainage system in the lower part of the ablation area Störglaciaren, Sweden, *Journal of Glaciology* 34 217-227.
- SHARP, M.J., 1996.Weathering pathways in glacial environments: hydrological and lithological controls. In BOTTEREL,S.H.(Ed.) *Proc. VI International Symposium on the Geochemistry of the Earth's Surface*, Ilkley. 652-655.,
- SMART, C.C., 1983. The Hydrology of the Castleguard Karst, Columbia Icefields, Alberta, Canada. *Arctic and Alpine Research*, 15.4, 471-486.
- SMART,C.C., 1994.Paraglacial karst: landform evolution on deglaciation. *International Association for Geomorphology*, Hamilton. Abstract.
- SMART,C.C., 1996. Statistical evaluation of glacier boreholes as indicators of basal drainage systems. *Hydrological Processes* 10 599-614.
- SMART, P.L., 1979.Catchment determination in a karst area by the use of quantitative tracer methods. *III Int. Symposium of Underground Water Tracing, Ljubjuna, Jugoslavia*, 291-298.
- WALDER, J.S.& HALLET, B., 1978 Geometry of former subglacial water channels and cavities. *Journal of Glaciology* 23 335-346.
- ZABO, L., 1995. *Fluorometric Tracing of Subglacial Hydrology, Small River Glacier, British Columbia, Canada*. Unpublished MSc Thesis, University of Western Ontario.

Underground water level regime of the Kungur cave region

K.A. Gorbunova, N.G. Maximovich & S.M. Blinov
Perm University, 4, Genkel Street, Perm, 61 4600, Russia

Kungur ice cave is located in the vicinity of Kungur city (Perm region) to the north-west of Ufimskoye plateau. The cave entrance is in the lower part of the northern side of Sylva river valley at the level of an aggradation terrace. The terrace width near the cave entrance is 100-150 m, and downstream the terrace pinches out and valley side borders the river. The total length of the cave is 5,6 km.

The cave is formed in gypsum and anhydrite of the lower part of Lower Permian Kungur state Iren horizon, and is represented by an alternation of gypsum-anhydrite and limestone-dolomite members. In the lower part of the cave dolomite of the Filippovsky horizon is found. Eluvial loam and detrital-shaly sediments with a thickness exceeding 10 m cover the Lower Permian rocks. The field over the cave is complicated by numerous sinks, the largest ones being situated over large grottos.

The south-eastern part of the cave near the entrance is cold. Various ice crystals, stalagmites, stalactites, columns, and overflow ice are found here. The central and north-western parts of the cave are notable for the lakes, numbering more than 60. The cave is horizontal, grottos and passages are aligned mainly north-east and north-west east and north-west.

Karst water in the cave occurs on the dolomite. Water containing rocks are cleaved karstic gypsum, anhydrite and detrital-shaly products of rock destruction. The aquifer is recharged by atmospheric precipitation absorbed by numerous sinks above the cave, condensation water of aeration zone, with a thickness of 70-80 m, and river water during the flood period. Karst water in the cave is exposed by 3 wells and basins of underground lakes.

The regime of the karst water is influenced by climatic, hydrologic and geologic factors. The climate of the region is moderate continental, and average annual precipitation is about 500 mm. Maximum precipitation occurs in summer time. Snow cover lasts up to 180 days a year. Climatic factors cause seasonal fluctuations of regime data. They influence the flood height and level of river and karst waters. The influence of hydrological factors is expressed by close connection of cave karst water level with Sylva river level. During the flood period river water penetrates in cave massif for a short time by infiltration into alluvial deposits of the first terrace or by inflow into the karst rocks adjacent to the river. The lowest levels of river water (low-flow) are registered in the winter and before flood.

The following geological factors influence the karst water regime: the degree of fissuring and karsting of rocks, their composition and conditions of occurrence.

According to G.N.Kamensky's classification the cave massif is attributed to the nearbank type of regime. In heavily karsted areas the nearbank regime is changed by absorption regime and far away from the river it is changed by divide regime. Hydrochemical observations showed that after the flood period the mineralization of sulfate-calcic karst water decreases. Water becomes aggressive to gypsum and anhydrite. Seasonal fluctuations of rock and water temperature, air humidity, wind regime, level and mineralization of karst water are the factors that promote karst processes and cause the evolution of this complex cave system.

Groundwater recharge in thermoglacial karst springs, South Spitsbergen.

Stein-Erik Lauritzen

Department of Geology, University of Bergen
Allégaten 41, N-5007 Bergen, Norway
stein.lauritzen@geol.uib.no

The Hilmarfjellet karst, South Spitsbergen, is an extreme end-member case in the hydrological interaction between karst and glacier aquifers. The hydrogeology of the powerful karst spring, Trollosen, and other springs in the vicinity was investigated with respect to subglacial recharge. The karst appears to pirate almost all discharge from Vitkovskibreen (the nearest glacier) and deliver a mixture of glacial meltwater and deep thermal water. Trollosen discharged turbid water at a rate of $13\text{--}15\text{ m}^3\text{ sek}^{-1}$ at $3.9\text{--}4.1\text{ }^\circ\text{C}$ in July 1992. Chemohydrographs, isotopic studies and water tracing experiments suggests an aquifer structure as depicted below (Figure 1), where substantial amounts of supra- and englacial meltwater enter the karst aquifer, where it is mixed with saline, thermal water; the mixing ratio of the two depending on the discharge.

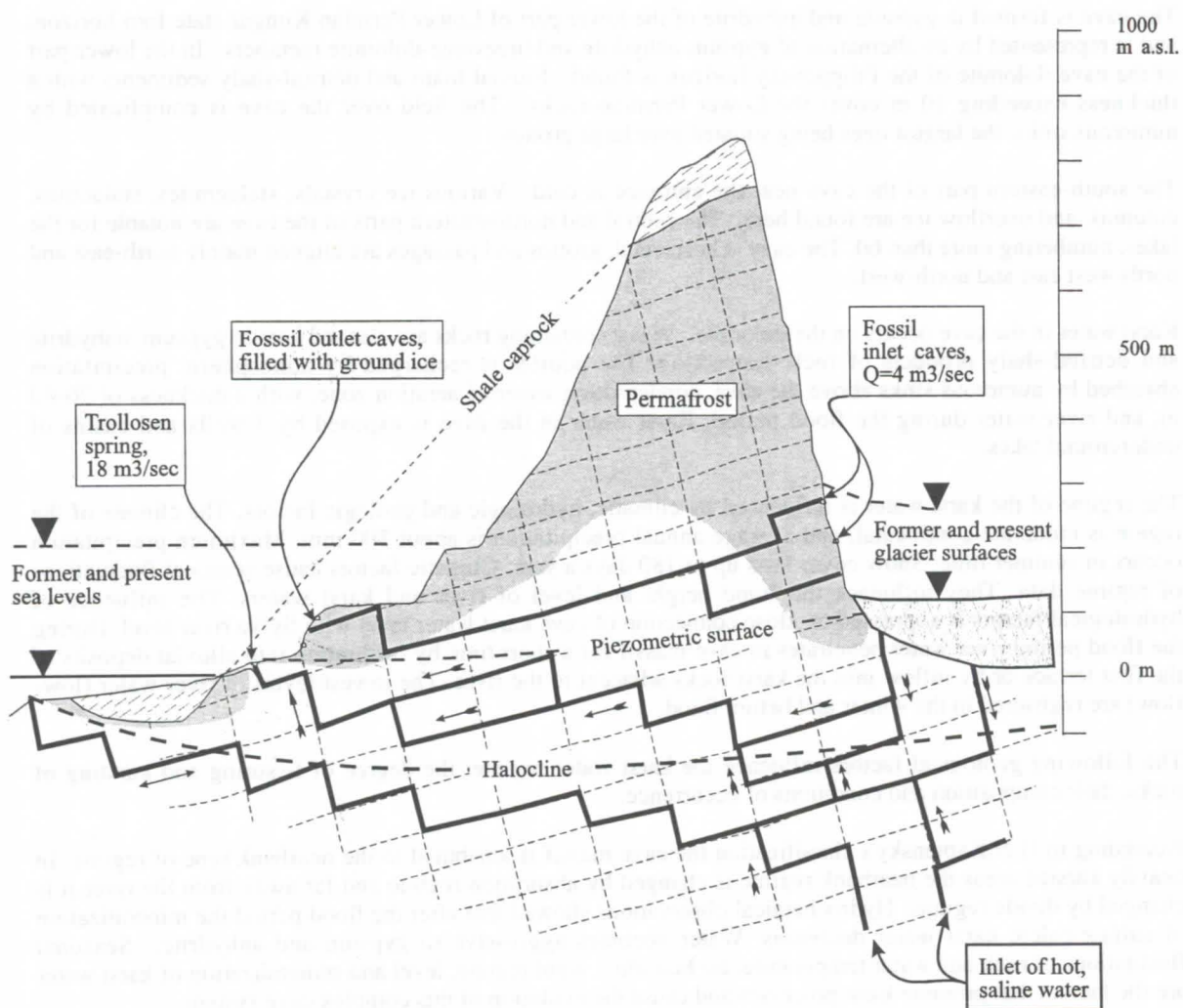

Figure 1. Conceptual model of the internal structure in Hilmarfjellet karst aquifer, Sørkappland, Spitzbergen.

References

LAURITZEN, S.E. & BOTTRELL, S. 1994: Microbiological activity in thermoglacial karst springs, South Spitsbergen. *Geomicrobiology journal* Vol. 12, pp 161-173.

LAURITZEN, S.E. 1996: Interaction between glacier and karst aquifers: Preliminary results from Hilmarfjellet, South Spitsbergen. *Kras i Speleologia (XVII)*, pp17-28

Studies on the mechanism of tidal phenomena observed in the Aggtelek karst region

L. Maucha

Water Resources Research Centre (VITUKI) Plc 1095 Kvassai Jenő út 1, Budapest, Hungary

Abstract

Tidal phenomena have been observed in the yield hydrographs of some springs and in the fluctuations of the karst water table. These have been traced back to tidal deformations of the solid crust, as demonstrated by the parallel fluctuations of the vertical lithoclase fissure with measured in one cave and the lunisolar gravity curve. The shear displacement of the rock faces in the fissure observed revealed simultaneously changes, which resembled the fluctuations observed in the yield time series of the cave spring. The most frequent tidal fluctuation observed in spring discharge had a period of close to 6 hours, whereas the period of tidal fluctuation is close to 12 hours. This contradiction has prompted in the development of the "collapsible fissure grid model", by the application of which the causes of the observed changes could be interpreted and the role of the rainfall load in the tidal fluctuation appearing in the spring discharge hydrograph could be identified.

Zusammenfassung

In der Schüttungsänderung einiger Quellen und auch in der Schwankung des Karstwasserniveaus in dem Aggteleker Karstgebiet könnte man Gezeiten-Erscheinung beobachten. Die Erscheinung wird durch die Gezeiten-Deformation der Erdkruste verursacht. Das wird von der Tatsache bewiesen, dass die Kluftbreite der senkrechte Lithoklase in einer Höhle hat gleiche Fluktuation mit der lunisolaren Gravitationskurve gezeigt. Gleichzeitig konnte man in dem gemessenen Bruch die Scherbewegung der gegenüberstehenden Wandoberflächen zu der Zeitreihe der Quellflut und Gezeiten-Schwankung ähnliche Änderung beobachten. Die häufigste Periodenzeit des Gezeiten-Änderung der Quellschüttung beträgt beinahe 6 Stunden. Die Periodenzeit der Gezeiten-Schwankung ist gegenüber beinahe 12 Stunden. Dieser Widerspruch führte uns zur Ausarbeitung des "Zusammenklappbaren Bruch-Gitter-Modells", mit seiner Anwendung konnte man die Ursachen der gennengelernten Änderungen interpretieren, und haben wir die Rolle des Niederschlags in den Gezeiten-Schwankung der Quellschüttung erkannt.

1. Introduction

Evidence of tidal fluctuation was detected in the yield changes of four springs emerging in the Aggtelek karst area. Fluctuations attributed to tidal effects were observed in the yield of the Kis-Tohonya spring at the beginning, middle and end of the recession period after storm triggered floods. Following the peak of the flood hydrograph sudden yield drops, in the middle period of recession yield fluctuations of appr. 6-hour period, while towards the end of the falling limb a succession of yield increases were registered repeatedly. Continuous 12 - 24 hour fluctuations in the karstwater level, at mean water close to 6-hour tidal fluctuation were also observed. According to the most recent measurements, the amplitude of waterlevel changes caused by tidal effects was 20 cm in dolomite and 2 cm in limestone.

2. The mechanism of tidal phenomena in karst region

For exploring the mechanism of the phenomenon, a measuring station on lithoclase fluctuation was established in a passage developed along one of the main faults in the Vass Imre cave. The instruments were set up to enable expansion between the opposite cave walls further horizontal-vertical shear displacements to be measured with

0.1 micrometer accuracy. The expansion movements were found to describe in a manner similar to gravimeters the time series of lunisolar fluctuations in identical and opposite phases as well. The shear displacements, on the other hand, were found to change parallel and opposite to the yield time series of the Kis-Tohonya spring which drains the cave. The relative rock movements along the cave varied from 0.5 to 5 micrometers. The measurement data provided clear evidence that relative movements of the rock masses situated on the two sides of the lithoclase were caused not only by the tidal phenomenon of the crust, but also by the weight of precipitation. It was of interest to clear the mechanisms by which this particular interaction is realised.

The main fault network dissects the Aggtelek karst into elementary rock blocks of rd. 50 by 50 m area in plan. Compression at low tide and expansion at high tide causes the fault network to perform movements resembling those of a collapsible grid. (Fig. 1.) In the course thereof the approximately square basic pattern of the elementary blocks is changed to a trapezoidal form both by tension during high tides and by compression during low tides. The reason why the shear displacements of the lithoclase fluctuations follow the shape of the hydrograph of spring yields

THE EFFECT OF PRECIPITATION LOAD

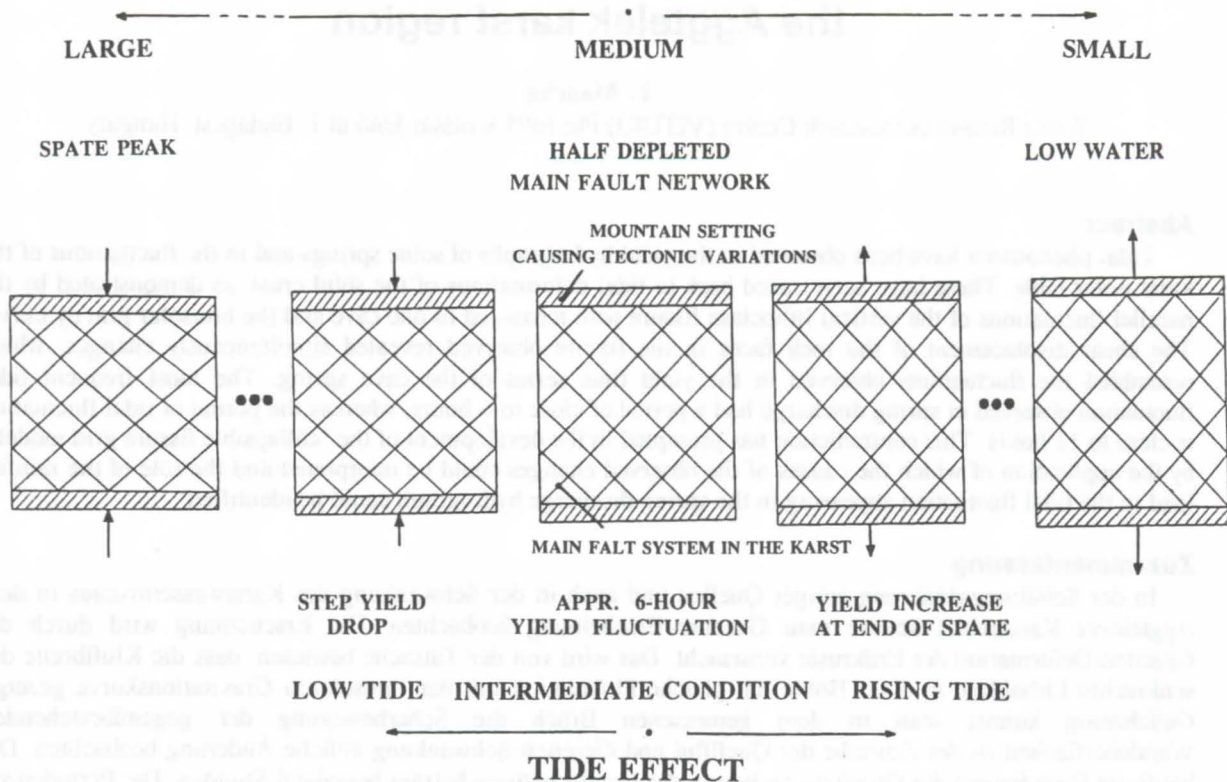

Fig. 1. Deformation of the fissure network in karstified rock under variable precipitation load. This is responsible for the appreciable effect at medium load of the much weaker tidal influence in opening and closing the main fissure network. The place of the hydrologic phenomena accompanying these changes are also indicated.

is that the same movement of the fault network is caused also by precipitation falling on, and infiltrating from, the surface, and subsequently by the depletion of the karst. These latter movements are, however, larger by one order of magnitude than the former. The weight of precipitation is sufficiently large to cause, under the principle of isostatics, 1-2 mm depression and horizontal compression of the karstified rock mass. As a consequence thereof, the precipitation load is capable of controlling the development of the different kinds of tidal fluctuation.

After the passage of the hydrograph peak, the tide causes an increase of the pore volume by expanding the fault network for a few hours. This results in the sudden yield drops. However, the compressed system has a higher internal friction, and for this reason these changes appear in a random manner in periods, when internal friction is reduced by seismic effects. On the boundary of the tensioned-compressed states (where the pore volume is largest), the fault network is contracted in high- and low tide periods alike, which leads necessarily to the development of the rd. 6 hour period in yield fluctuation (the tidal period is halved). At the end of the hydrograph the system is in a tensioned state (this being the normal state). Under such conditions high tides can and do cause yield increases of 12 hour or longer period alone.

3. Conclusions

The "collapsing fault grid" model has thus provided an explanation for the phenomenon that in the case of a normal precipitation load the karst tidal phenomenon results in a decrease of rock porosity at high- and low tides alike. In such periods maximum pore volume occurs around the point of counterflexure on the lunisolar curve. At high precipitation loads it is the low tide, whereas at low loads the high tide, which cause the pore volume to drop. In low-water periods a precipitation load will cause first an increase, then a decrease in pore volume, while at high loads the porosity is decreased only. The influence of these actual microtectonic changes on pore volume was verified in all respects by the measurement data.

Literature

- MAUCHA, L. 1968. Ausweise der Gezeiten-Erscheinungen des Karstwasserspiegels. Budapest, Hungary. *Karszt és Barlangkutatás* Vol. V. 101-116. (in German)
- MAUCHA, L. 1995. Studies of the mechanism of tidal phenomena in karstified rocks in the Vass Imre cave. Budapest, Hungary. *Karszt és Barlangkutatás*. Vol. 10. 71-101. (in Hungarian)

Authors' Index

AAEMM	III	191	Borowsky Richard	III	359	Damyantov Y.	I	111
Abbate R.	II	205	Borsato Andrea	I	247	Damyantov Y.	I	105
Abdul-Nour Hani	III	35	Borsato Andrea	I	77	Damyantov Y.	I	107
Abul-Hab Jalil	III	369	Borsato Andrea	II	57	Damyantov Y.	I	110
Adank Markus	IV	65	Boutin Claude	III	350	Damyantova A.	I	110
Adbesselam Malek	II	247	Boyd Clifford C.	III	37	Damyantova A.	I	111
Aigoun C.	II	247	Brandt Cyrille	IV	71	Damyantova A.	I	105
Aimé Gérard	III	5	Brouquisse François	II	299	Damyantova A.	I	107
Allison Cara	I	16	Brouquisse François	II	61	Daoxian Yuan	I	300
Ancel Bruno	III	195	Brouquisse François	IV	47	Daoxian Yuan	II	123
Ancel Bruno	III	245	Buchas Holger	I	453	Day Michael J.	I	133
Ancel Bruno	III	249	Bulichov Anatoly	V	89	Day Michael J.	I	215
Andreev Sergiu P.	III	321	Bundschuh Jochen	II	129	de Bonis L.	I	424
Andreo B.	II	251	Burri Ezio	II	201	De Broyer C.	V	103
Arcenegui Rocio	I	183	Buzjak Nenad	III	301	De Paola Marco	I	202
Argant Alain	III	105	Calvet Jean-Paul	III	261	Décréau Frédéric	III	91
Argant Alain	III	160	Cañaveras J. C.	II	103	Deflandre G.	I	93
Arlt Thilo	III	203	Capellini Dante Terence	III	145	Deharveng Louis	IV	47
Arlt Thilo	III	253	Cappa Emanuele	III	9	Delaby Serge	IV	111
Arlt Thilo	III	257	Cappa Emanuele	IV	79	Delaby Serge	IV	115
Armand Dominique	III	109	Cappa Giulio	III	9	Delannoy Jean-Jacques	I	61
Arrigo Cyril	IV	13	Cappa Giulio	IV	79	Delannoy Jean-Jacques	II	69
Astruc J.-G.	I	424	Carlson Kent R.	III	347	Delannoy Jean-Jacques	I	257
Atteia Olivier	II	125	Carrasco F.	II	251	Dematteis Antonio	II	291
Atteia Olivier	II	141	Casati Luigi	IV	67	Denneborg Michael	I	341
Audra Philippe	I	165	Cassou Jean-Pierre	V	53	Denys Christiane	I	424
Audra Philippe	I	337	Castellani Vittorio	III	265	Denys Christiane	III	165
Audra Philippe	I	429	Castellani Vittorio	III	269	Denys Christiane	III	178
Auler A.	II	271	Cech Brigitte	III	209	Destombes Jean-Luc	I	257
Ayub Soraya	IV	45	Chabert Jacques	IV	83	Destombes Jean-Luc	II	69
Ayub Soraya	V	35	Chabert Jacques	V	111	Destombes Jean-Luc	I	61
Badescu Adrian	I	25	Changyun Zhang	IV	55	Dimuccio Luca Antonio	I	202
Badino Giovanni	I	483	Chauve Pierre	II	247	Dimuccio Luca Antonio	I	400
Bakalowicz Michel	II	23	Chazine Jean-Michel	III	101	Djurovic Predrag	I	421
Bakalowicz Michel	II	55	Choppy Jacques	I	3	Dodelin Christian	V	73
Balbi A.	I	69	Choppy Jacques	I	367	Doerfliger Nathalie	II	133
Balderer Werner	II	275	Choppy Jacques	I	401	Doerfliger Nathalie	II	209
Banton O.	II	283	Choppy Jacques	IV	83	Doerfliger Nathalie	II	47
Barczewski M.	II	55	Christe Romain	II	221	Dogwiler Toby	I	178
Barredo Silvia P.	I	69	Cigna Arrigo A.	I	203	Dominguez Carmen	I	485
Barsanti Cecilia M.	III	217	Cimino Antonio	II	205	Dragan-Bularda Mihail	III	285
Bartholeyns Jean-Pierre	V	103	Cinq-Mars J.	II	287	Dragoni Walter	III	265
Bärtschi Hans-Peter	III	233	Clarck I. D.	II	287	Draily Christelle	III	61
Bayle Christian	II	1	Clemens Torsten	I	301	Dreybrodt Wolfgang	II	75
Becker José Henrique	V	35	Clemens Torsten	II	107	Dreybrodt Wolfgang	II	81
Bedos Anne	IV	47	Clemens Torsten	II	65	Drouin Philippe	IV	119
Bella P.	I	85	Clemens Torsten	I	307	Drouin Philippe	III	113
Benderev Alexey	II	255	Closson Damien	V	13	Drysdale R. N.	I	73
Bengeanu Monica	I	235	Closson Damien	I	322	Du Fayet de la Tour Alain	III	79
Benischke Ralf	I	425	Clottes Jean	III	103	Dublyansky Yuri V.	II	267
Bernasconi Reno	III	333	Clottes Jean	III	4	Dublyansky Yuri V.	I	271
Bernasconi Reno	III	337	Coca Spencer	IV	87	Dubois Paul	I	3
Berstad Ida Malene	I	53	Codrea Vlad	III	179	Ducimetière Pascal	IV	13
Bini Alfredo	I	345	Coineau N.	III	350	Duday Henri	III	79
Bitinskaya L. N.	V	31	Collet Guy-Christian	III	83	Duffaud S.	I	424
Bitterli Thomas	IV	5	Collignon Bernard	II	263	Dumont Laurent	IV	13
Bitterli Thomas	I	349	Collignon Bernard	IV	57	Ehret Michel	III	221
Bixio Roberto	III	269	Cordonnier M.	II	69	Einevoll Sølvi	I	53
Bland J.	I	111	Cortel Adriano	I	183	Eisenlohr Laurent	II	81
Blinov S. M.	II	319	Cortel Adriano	I	179	Eiswirth Matthias	II	213
Blondel C.	I	424	Coste Thierry	V	85	Ek Camille	I	297
Bock Matthias	III	199	Cours Serge	III	79	Ek Camille	I	322
Bodin Jacques	II	259	Cox Nicholas J.	I	285	Ek Camille	V	13
Boehm Peter	III	203	Craven Stephen Adrian	V	15	Emblanch Christophe	II	17
Bohly Bernard	III	221	Crochet Jean-Yves	I	424	Emblanch Christophe	II	5
Bolanz Jean-Jacques	IV	75	Cruz C. M.	II	95	Engel Scott	I	21
Bolliger Thomas	III	141	Cruz de la A. V.	II	95	Epis Lorenzo	V	29
Bonacci Ognjen	II	27	Dalmeri Gianpaolo	I	77	Eraso Adolfo Romero	I	483

Eraso Adolfo Romero	I	485	Ginés Angel	I	37	Hückinghaus Dirk	II	107
Espinasa Luis	III	359	Ginés Joaquin	I	37	Hückinghaus Dirk	II	145
Eszterhás István	I	469	Glazek Jerzy	I	85	Hückinghaus Dirk	II	65
Faeh A.	II	9	Glazek Jerzy	I	405	Huff Warren	I	25
Fage Luc-Henry	III	101	Glazek Jerzy	I	45	Huggenberger Peter	II	221
Faillat Jean-Pierre	II	111	Glowacki Piotr	I	366	Huntoon Peter W.	I	311
Faillat Jean-Pierre	II	85	Gobrunova K. A.	II	319	Imper David	III	229
Fairchild Ian J.	I	247	Goggin Keith E.	I	381	Isayevitch A. G.	V	31
Fang Jinfu	I	395	Gogniat Stéphane	II	229	Jaillet Stéphane	I	171
Farina Daniele	I	143	Goldie Helen S.	I	285	Jalov Alexey	IV	25
Favre Gérard	IV	13	Goodbar James	V	3	Jambresic Gordana	III	157
Felici Alberta	IV	79	Grady Frederick	III	175	Jan Vit	I	45
Felici Alberto	III	9	Gradzinski Michal	I	275	Jeanbourquin Pascal	II	13
Felisiak Ireneusz	I	17	Gradzinski Michal	I	81	Jeannin Pierre-Yves	I	195
Ferguson Lynn M.	III	315	Gradzinski Michal	I	85	Jeannin Pierre-Yves	II	149
Fernandez-Jalvo Yolanda	III	165	Gradzinski Michal	IV	91	Jeannin Pierre-Yves	II	91
Fiedler Suzana	III	301	Grandgirard Vincent	I	331	Jeannin Pierre-Yves	IV	1
Filippov Andrey G.	I	465	Grasso Alessandro D.	II	91	Jeannin Pierre-Yves	I	293
Fischer M. J.	I	73	Guadelli Jean-Luc	III	117	Jeannin Pierre-Yves	I	349
Fluck Pierre	III	187	Guardiario J. D. A.	II	199	Jifang Shen	IV	55
Foltete Jacques	I	169	Guglielmi Yves	II	137	Johnson Jerald	III	41
Font Estramar, Ass. Rech.	IV	71	Guyot Jean Loup	IV	51	Jonsson Sigurdur S.	I	485
Ford Derek C.	I	44	Guyot Jean-Loup	II	271	Jordan P.	II	275
Ford Derek C.	I	88	Guzvica Goran	III	121	Jordi Martin	V	77
Ford Derek C.	II	120	Habermann Dirk	I	251	Jull Timothy A. J.	I	65
Ford Derek C.	II	195	Halliday William R.	I	437	Junwei Wan	IV	55
Ford Derek C.	I	105	Halliday William R.	I	199	Kadlec Jaroslav	I	13
Ford Derek C.	I	107	Halliday William R.	I	461	Kadlec Jaroslav	I	387
Ford Derek C.	I	111	Hanneberg Armin	III	203	Kalmbach Uwe	IV	29
Ford Derek C.	I	146	Hanneberg Armin	III	253	Karlén W.	I	55
Ford Derek C.	I	261	Hanneberg Armin	III	257	Kashima Naruhiko	III	281
Ford Derek C.	I	262	Hapka Roman	III	3	Käb Werner	II	187
Forgeot Olivier	I	9	Hapka Roman	III	57	Käb Werner	II	55
Fornos Joan J.	I	37	Harlacher Christof	I	307	Kawashiti I. S.	III	371
Forti Paolo	I	187	Hartenberger J.-L.	I	424	Kejonen Aimo	III	53
Forti Paolo	I	226	Hartmann A.	II	239	Kejonen Aimo	IV	93
Fosse Philippe	III	149	Hartmann Jens	I	100	Kempe Stephan	I	100
Fratila Gheorghe	III	179	Hartmann Jens	I	453	Kempe Stephan	I	453
Fratila Gheorghe	I	231	Hassan H. A.	III	371	Kempe Stephan	III	13
Frisia Silvia	I	247	Hauns Michael	II	141	Kempe Stephan	I	445
Frisia Silvia	I	77	Häuselmann Philipp	II	31	Kempe Stephan	I	449
Frumkin Amos	I	139	Häuselmann Philipp	IV	1	Keppens E.	I	93
Fuchs Gerald	I	425	Havlicek David	I	481	Ketz-Kempe Christhild	III	13
Funcken Luc	III	205	Heaton Tim	I	77	Kicinska Ditta	I	168
Funcken Luc	IV	7	Heijnis H.	I	73	Kienle J.	II	163
Funcken Luc	IV	9	Heller Martin	V	127	Kiss Stefan	III	285
Furquim Scaleante Oscarlina A.	I	363	Hercman Helena	I	45	Klimchouk Alexander	I	157
Gaál Lúdvít	I	464	Hercman Helena	I	85	Klimchouk Alexander	I	161
Gabrovsek Franci	IV	23	Hercman Helena	I	87	Klimchouk Alexander	I	306
Gadat J.-Y.	II	69	Hermann Felix	II	141	Knez Martin	II	279
Gaiffe M.	I	297	Herold Thilo	II	275	Knez Martin	I	156
Galdenzi Sandro	I	187	Hill Carol A.	I	226	Korshunov Viktor A.	I	29
Gale S. J.	I	73	Hill Carol A.	I	390	Korzhyk Vitali	V	7
Galik Alfred	III	65	Hobbs III H. H.	III	345	Kósa Attila	V	129
Gallerini Giuliano	I	143	Hobléa Fabien	II	35	Kosel Vladimir	III	310
Garasic Mladen	IV	123	Hobléa Fabien	I	429	Kostov Konstantin	I	409
Garasic Mladen	IV	125	Hof Alex	I	137	Kovacevic Tihomir	IV	125
Garasic Mladen	I	147	Hofenpradli Angelica	I	235	Krasnoshtein Arkady E.	V	31
Garcia A. E.	II	95	Hoffmann Guido	V	65	Krawczyk Wieslawa Ewa	I	493
Garcia Michel	III	79	Holland Ernst	V	39	Krekeler Mark P. S.	I	21
Gaspar E.	I	41	Holler Cato Jr.	III	305	Krklec Nevenka	III	157
Gaspar Radu D.	II	175	Holmgren K.	I	55	Krouse Roy H. P.	I	105
Gaspar Radu D.	II	217	Holsinger John R.	III	347	Krouse Roy H. P.	I	107
Genereux D.	II	199	Horat Peter	II	9	Krouse Roy H. P.	I	65
Genty Dominique	I	61	Hoti Makir	IV	129	Krutaj Farudin	IV	129
Genty Dominique	I	257	Hötzl Heinz	II	187	Kusch Heinrich	III	17
Georgiev L. N.	I	105	Hötzl Heinz	II	213	Labau V.	I	41
Georgiev L. N.	I	107	Hötzl Heinz	II	303	Laconas Erikas	III	169
Ghargari Lucretia	I	231	Hoyos M.	II	103	Lami H.	II	247
Ghargari Lucretia	I	227	Huang Yiming	I	77	Larocque Marie	II	283
Giannandrea Paolo	I	202	Hubbard David	III	37	Lascu Cristian	I	25
Gietl Diana	I	497	Hubbard David	III	175	Lastennet Roland	II	17
Gillieson David	I	327	Hubbard David A. Jr.	III	311	Lastennet Roland	II	5

Laudet Frédéric	I	424	Masotti Daniel	V	9	Oelze Rainer	I	251
Laudet Frédéric	III	165	Massoli-Novelli R.	II	201	Onac Bogdan Petroniu	I	235
Laudet Frédéric	III	178	Matthews Peter	V	72	Onac Bogdan Petroniu	I	227
Laureti Lamberto	III	236	Matthews Peter	V	72	Onac Bogdan Petroniu	I	231
Lauriol Bernard	II	287	Matthews Peter	V	72	Orecchio S.	II	205
Lauritzen Stein-Erik	I	178	Maucha Laszlo	II	157	Otonicar Bojan	I	417
Lauritzen Stein-Erik	I	45	Maucha Laszlo	II	321	Otz Martin	II	31
Lauritzen Stein-Erik	I	55	Mauduit Eric	III	261	Paar Werner	III	209
Lauritzen Stein-Erik	I	57	Mavlyudov Bulat R.	I	191	Pacher Martina	III	65
Lauritzen Stein-Erik	I	85	Maximovich N. G.	II	319	Pajón Morejon Jesús M.	I	97
Lauritzen Stein-Erik	II	320	McDermott Frank	I	77	Pajón-morejón Jesús M.	II	95
Lauritzen Stein-Erik	I	49	Mecchia Marco	I	483	Pandurska Rumiana	III	367
Lauritzen Stein-Erik	I	53	Medville Douglas M.	I	381	Partridge T. C.	I	55
Le Bec G.	II	111	Medville Douglas M.	I	457	Pascu Maria	II	175
Le Penne Robert	II	39	Medville Hazel E.	I	457	Pashenko Serguei E.	I	271
Lee-Thorp J.	I	55	Meier Edi	II	221	Patrick Rosenthal	III	225
Leel-Ossy Szabolcs	I	116	Melloul Abraham J.	II	225	Paunica I.	III	217
Legendre S.	I	424	Melo Filho Leonildes	IV	51	Paunica T.	I	41
Lesinsky Gabriel	III	325	Melo-Filho Leonildes	II	271	Pavuz Rudolf	I	7
Leszkiewicz Jan	I	489	Menichetti Marco	I	187	Pechhold Eberhard	I	211
Lewandowski Klaus	III	213	Menne Benjamin	II	119	Pedde Sara	III	67
Lhenaff R.	I	297	Menne Benjamin	IV	33	Perego Renata	III	124
Li Juzhang	I	395	Menne Benjamin	III	289	Perego Renata	III	136
Liedl Rudolf	II	107	Messouli M.	III	350	Perna Giuliano	I	397
Liedl Rudolf	II	145	Meus Philippe	II	55	Perret Catherine	IV	65
Liedl Rudolf	II	153	Michel G.	V	103	Perret Jean François	IV	51
Liedl Rudolf	II	65	Michel J.	V	81	Perrette Yves	I	257
Liedl Rudolf	I	195	Michel Raymond	V	13	Perrette Yves	I	61
Liessmann Wilfried	III	237	Michie Neville	V	43	Perrin Jérôme	II	99
Lignereux Yves	III	71	Middleton Gregory	I	437	Perrin Jérôme	IV	19
Lin Junshu	I	395	Mihevc Andrej	I	57	Petitta Marco	II	201
Linge Henriette	I	49	Mijatovic Borivoje F.	II	295	Petrochilou Anna	III	64
Lips Bernard	IV	41	Miserez Jean-Jacques	II	229	Philippe Michel	III	113
Liu Zaihua	I	300	Mixon David	I	21	Philippe Michel	III	125
Liyanyun X. C. C.	II	21	Mohrlök Ulf	II	163	Philippe Michel	III	136
Ljubojevic Vladimir	I	421	Mohrlök Ulf	II	167	Philippe Michel	III	161
Lochner Bernd	III	241	Moldovan Oana	III	319	Pinto Ana Cristina	III	171
Loiseleur Bernard	I	355	Montandon Paul-Etienne	II	229	Plagnes Valérie	II	179
Loiseleur Bernard	I	441	Montero Garcia Ismael Arturo	III	20	Plesa Corneliu	III	329
Longinelli Antonio	I	247	Montero Garcia Ismael Arturo	V	80	Porter Megan L.	III	345
Looser Michel	II	291	Morel Laurent	V	99	Postawa A.	II	235
López-Chicano M.	II	43	Morel Philippe	III	3	Preiswerk Christian	IV	37
Lowe David J.	I	436	Morel Philippe	III	137	Prokhorenko Vitaliy	V	93
Lozan Mina N.	III	321	Morin Denis	III	225	Prokhorenko Vitaliy	V	95
Lundberg Joyce	I	178	Motyka Jacek	II	171	Proudlove Graham S.	III	351
Lundberg Joyce	I	101	Motyka Jacek	II	235	Proudlove Graham S.	III	355
Macaluso M.	II	205	Mouret Claude	II	299	Puech Vincent	I	293
MacDonald William D.	I	105	Mouret Claude	IV	57	Puig J. M.	II	5
MacDonald William D.	I	107	Mouret Claude	III	363	Pulido-Bosch Antonio	II	43
MacDonald William D.	I	60	Mousny Vincent	V	13	Pulina Marian	I	323
Madry B.	II	81	Mudry Jacques	II	137	Pulina Marian	I	366
Magniez Guy J.	III	341	Mudry Jacques	II	17	Pulina Marian	I	489
Maire Richard	I	359	Mudry Jacques	II	247	Pulina Marian	I	493
Maltsev Vladimir A.	I	29	Mudry Jacques	II	251	Quinif Yves	I	93
Maltsev Vladimir A.	I	219	Mudry Jacques	II	5	Quinif Yves	I	257
Maltsev Vladimir A.	I	267	Mueller Robert J.	I	215	Quinif Yves	I	61
Mangan C.	II	137	Muglova Penka	III	95	Radanovic-Guzvica Biserka	III	121
Mangin Alain	II	283	Muglova Penka	I	207	Rage J.-C.	I	424
Mania Jacky	II	247	Mulaomerovic Jasminko	III	87	Ragsdale Michael	I	21
Manolache Elena	III	285	Müller Claudia	I	301	Rathgeber Thomas	III	153
Marandat B.	I	424	Müller Elisabeth	II	239	Ravazzi Cesare	III	124
Maréchal Jean-Christophe	II	149	Müller Imre	II	221	Razack M.	II	259
Maréchal Jean-Christophe	II	291	Müller Imre	II	243	Razack M.	II	283
Marinova E.	I	107	Muñoz Alfonso	I	179	Ré G.	I	69
Martin Philippe	I	129	Munson Cheryl Ann	III	45	Redonte Gabriel Jorge	IV	99
Martín Rosales W.	II	43	Munson Patrick J.	III	45	Rehák Josef	I	493
Martinek Klaus-Peter	III	253	Mylroie John E.	I	178	Reichert Barbara	II	303
Martinek Klaus-Peter	III	257	Naef F.	II	9	Reiner Gerhard	III	181
Martini Jacques E.J.	I	223	Niggemann Stefan	I	251	Reisinger Christian	III	129
Martini Sergio	III	217	Niggemann Stefan	I	151	Reisner Victor	IV	103
Martini Sergio	I	315	Nini Roberto	III	273	Remy J.-A.	I	424
Masotti Daniel	V	21	Oberwinder Matthias	I	453	Renner Sven	II	153
Masotti Daniel	V	25	Oberwinder Matthias	I	449	Reynard Emmanuel	V	17

Reynaud A.	II	137	Sigé B.	I	424	Vacquié Jean-François	IV	57
Richter Detlev K.	I	251	Simões Washington	III	83	Vadillo I.	II	251
Rigal Didier	IV	47	Simon-Coinçon R.	I	424	Valdés J. J.	II	95
Rogers Bruce W.	III	45	Singh Ramesh B.	I	369	Vallejos A.	II	43
Rognon P.	II	229	Slabe Tadej	I	377	van Beyden P. E.	II	120
Rosendahl Wilfried	III	25	Smart Chris C.	II	183	Van Beynen P. E.	I	262
Rospondek Mariusz	I	81	Smart Chris C.	II	315	Vanara Nathalie	II	115
Rossi Carlos	I	179	Smart Chris C.	II	51	Vanara Nathalie	I	359
Rossi Carlos	I	183	Smart Peter L.	I	16	Vasileva Danica	I	175
Russet Claude	II	307	Smyk Boleslaw	I	275	Vasiliev Andrey G.	III	321
Rouvinez Fabienne	III	57	Soler V.	II	103	Vendramini Guilherme	IV	51
Rouzaud François	III	261	Somelette Luc	II	111	Veni George	I	373
Rouzaud François	III	49	Song Linhua	I	279	Verheyden Sophie	I	93
Rouzaud François	III	71	Song Linhua	I	319	Verheyden Sophie	IV	111
Rouzaud François	III	79	Song Linhua	I	433	Verheyden Sophie	IV	115
Rouzaud François	III	97	Souillac, Spéléo-Club de	III	161	Versa Dorotea	V	69
Rouzaud François	III	91	Soulier Michel	III	71	Vianey-Liaud M.	I	424
Rouzaud Jean-Noël	III	91	Spahlinger Wolf	IV	29	Viehmänn Iosif	I	227
Rowling Jill	I	263	Spicher Michel	I	331	Viehmänn Iosif	III	133
Rozkowski Jacek	I	323	Spiro Baruch	I	77	Vremir Matei	I	413
Rubbioli Ezio	IV	51	Stibrányi Gustáv	V	119	Wan Junwei Y.	II	21
Ruggieri Rosario	IV	61	Stichler W.	II	303	Wang Daqing	III	311
Ruggieri Rosario	I	125	Stiefelhagen Willy	II	221	Wang Fuchang	I	433
Saiers J. E.	II	199	Stoiev Alexey	I	207	Watson Patty Jo	III	29
Salvatori Francesco	V	107	Stoiev Alexey	III	95	Weber Dieter	III	307
Salvatori Francesco	V	115	Stoiev Dimitar	I	207	Weidmann Yvo	IV	37
Salvatori Francesco	V	117	Stoieva Mina	III	95	Weidmann Yvo	IV	65
Sanchez-Moral S.	II	103	Strassenburg Jan	I	453	Weisgerber Gerd	III	216
Sanz-Rubio E.	II	103	Striebel Thomas	I	473	Weissensteiner Volker	I	425
Sarbu Serban	I	25	Stroutchkova Tatiana	III	78	Werner Andreas	II	187
Sasowsky Ira	I	25	Stuart-Williams Hilary	I	88	White Elisabeth L.	II	191
Sauter Martin	II	107	Sudre J.	I	424	White Elizabeth L.	I	155
Sauter Martin	II	145	Summers Engel Annette	I	21	White Elizabeth L.	I	305
Sauter Martin	II	153	Summers Engel Annette	I	25	White William B.	II	191
Sauter Martin	II	167	Sustersic France	I	117	White William B.	I	155
Sauter Martin	II	65	Swinburne Nicola	I	88	White William B.	I	305
Sauter Martin	I	195	Szulc Joachim	I	275	White William B.	I	89
Sauter Martin	I	301	Szulc Joachim	I	81	Wilcock John D.	V	61
Sauter Martin	I	307	Tacchini Pascal	IV	19	Willems Luc	I	477
Sauter Martin	I	318	Tamas Tudor	I	413	Williams Paul W.	I	92
Sbai Abdelkader	I	297	Tankersley Kenneth B.	III	75	Wollman S.	II	225
Sbai Abdelkader	II	311	Tankersley Kenneth B.	III	45	Wolniewicz Klaus	I	453
Schäferjohann Volker	I	473	Tarhule-Lips Rozemarijn F. A.	I	146	Wookey	V	57
Scherrer Nadim C.	I	73	Tarhule-Lips Rozemarijn F. A.	I	261	Worthington Stephen R. H.	II	195
Scherrer S.	II	9	Tasler R.	I	481	Wutzig B.	III	277
Schifferdecker François	III	137	Terlau Craig A.	I	133	Xiyang Xiao	IV	55
Schmid G.	II	55	Teutsch Georg	II	163	Xuewen Zhu	II	121
Schnegg Pierre-André	II	47	Teutsch Georg	II	65	Yaseen Ahmed E.	III	371
Schöne Tilo	III	277	Thys G.	V	103	Yonge Charles J.	I	107
Schwarz Henry P.	I	88	Tognini Paola	I	345	Yonge Charles J.	I	111
Schwarz Henry P.	II	120	Tomova Bisera	V	131	Yonge Charles J.	I	436
Schwarz Henry P.	I	262	Toth V. A.	II	120	Yonge Charles J.	I	65
Scott Jane	I	436	Toussaint Michel	III	21	Yonge Charles J.	I	105
Sebela Stanka	I	113	Tremblay Marc	I	497	Yonge Charles J.	I	60
Seiler Klaus-P.	II	239	Trimborn P.	II	303	Zabo L.	II	51
Semikolennykh Andrei A.	I	29	Trofimova Elena	I	391	Zaenker Stefan	III	307
Semikolennykh Andrey A.	V	87	Tsankov Ludmil T.	I	105	Zambo Laszlo	I	44
Semikolennykh Andrey A.	III	293	Tsankov Ludmil T.	I	107	Zechner Eric	II	199
Shanov Stefan	II	255	Tsankov Ludmil T.	I	110	Zhao Jingbo	I	300
Shanov Stefan	III	367	Tsankov Ludmil T.	I	111	Zhaohui Zhang	III	297
Shaw D. Patrick	III	347	Tsankov Ludmil T.	I	65	Zhu Xuewen	I	385
Shaw P. A.	I	55	Tuccimei Paola	I	37	Zhu Yuanfeng	V	47
Shelepin Aleksey	IV	103	Tulis Ján	IV	107	Zuber A.	II	171
Shen Jifang	II	21	Turberg Pascal	II	243	Zuccoli Luisa	I	345
Shopov Yavor Y.	I	105	Turchinov Igor	I	121	Zupan Hajna Nadja	I	33
Shopov Yavor Y.	I	107	Turchinov Igor	I	239	Zurbrügg Ch.	II	9
Shopov Yavor Y.	I	110	Tyc Andrzej	I	289	Zwahlen François	II	209
Shopov Yavor Y.	I	111	Tyc Andrzej	I	323			
Shopov Yavor Y.	I	65	Tyson P. D.	I	55			
Shopov Yavor Y.	I	103	Tysseiland Magne	I	235			
Shrivastava V. K.	III	31	Uhrin Marcel	III	325			
Siebenlist-Kerner V.	III	203	Urbani Franco	I	243			
Siemens H.	II	75	Usuloglu Ender	V	123			



Réseau de Covatannaz, VD, Switzerland (Photo Rémy Wenger)



Sarrazine: l'entrée lors d'une crue, France (Photo Pali Berg/Urs Widmer)

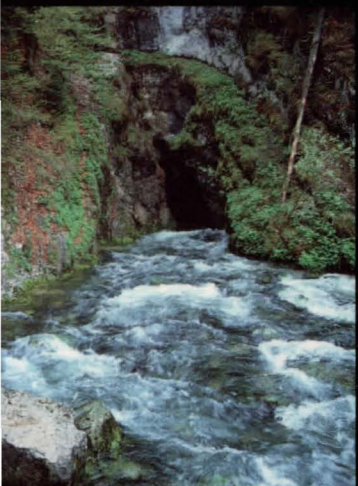

Source du Doubs, France (Photo Oliver Trueb)



Blautopf, Blaubeuren, Germany (Photo Pali Berg)