

ICS 2009

15TH INTERNATIONAL CONGRESS OF SPELEOLOGY

Proceedings, Volume 1

Symposia Part 1



OUR SPONSORS



Volume 1, Symposia, Part 1

Proceedings

15th International Congress of Speleology

**Kerrville, Texas
United States of America
July 19–26, 2009**

Editor:
William B. White

Cover design:
Beth Fratesi

Layout and design:
Greyhound Press



GREYHOUND PRESS

Library of Congress Control Number 2009930608
ISBN 978-1-879961-33-3

PROCEEDINGS

15TH INTERNATIONAL CONGRESS OF SPELEOLOGY

VOLUME 1

SYMPOSIA, PART 1

Kerrville, Texas

United States of America

July 19–26, 2009

Produced by the organizing Committee of the
15th International Congress of Speleology

Published by the International Union of Speleology

© 2009 National Speleological Society, Inc.

Individual authors retain their copyrights as indicated in the text. All rights reserved. No part of this work may be reproduced or transmitted in any form or by any means, electronic or mechanical, including photocopying, recording, or any data storage or retrieval system without the express written permission of the copyright owner. All drawings and maps are used with permission of the artists.

Unauthorized use is strictly prohibited.

Printed in the United States of America.

2005–2009 BUREAU OF THE INTERNATIONAL UNION OF SPELEOLOGY

President:	Andrew Eavis
General Secretary	Dr. Fadi Nader
Vice Presidents	Dr. Pavel Bosák Dr. Alexander Klimchouk
Adjunct Secretaries	Carlos Benedetto Roman Hapka Dr. Stein-Erik Lauritzen Efrain Mercado Dr. Andrej Mihevc Dr. George Veni Dr. Paul Williams Dr. Kyung Sik Woo

PRODUCTION OF THE PROCEEDINGS

Science Committee	Dr. Louise D. Hose (USA) – Chairman Dr. Joaquin Arroyo-Cabrales (Mexico) – Paleontology Dr. Penelope Boston (USA) – Life and Planetary Sciences Dr. James Brady (USA) – Archaeology Dr. Linda El-Dash (Brazil) – Stewardship/Social Sciences Dr. Alexander Klimchouk (Ukraine) – Earth Science/Exploration Dr. Donald McFarlane (UK and USA) – Paleontology/Earth Science Dr. Oana Moldovan (Romania) – Life Sciences Dr. José Palaciós-Vargas (Mexico) – Life Sciences Dr. James Pisarowicz (USA) – Exploration/Social Sciences Dr. Wilfried Rosendahl (Germany) Archaeology Dr. Patricia Seiser (USA) – Stewardship/Social Sciences Dr. Rickard Toomey (USA) – Paleontology/Stewardship Abel Vale (Puerto Rico) – Stewardship/Social Sciences Dr. George Veni (USA) – Earth Science/Archaeology Dr. Paul Williams (New Zealand) – Earth Sciences Dr. Kyung-Sik Woo (Korea) – Earth Sciences
Proceedings Editor	Dr. William B. White (USA)
Production Manager	G. Thomas Rea (USA)

Proceedings of the 15th International Congress of Speleology

Errata and Omissions

The Proceedings of the 15th International Congress of Speleology contain either abstracts or full papers of the 500 contributions presented at the Congress. The three volumes of the Proceedings total 2130 pages. The pathway to this mass of material was as follows: Prospective authors submitted an initial abstract to the ICS Science Committee. These abstracts were reviewed by the Committee to ascertain that the subject matter was appropriate for the Congress. The abstracts were then returned to the authors with suggestions and an invitation to prepare a full paper limited to six printed pages. Few papers were rejected, but some were withdrawn so that of 540 initial submissions, 500 were presented at the Congress. The draft papers were sent to the Science Committee who distributed them for review after which they were returned to the authors for such adjustments as the reviewers deemed necessary. The final papers were received by the Science Committee for formal acceptance and were forwarded to the editor. The edited papers were then transmitted to Production Manager for page layout and preparation for the printer.

All of this movement of abstracts and manuscripts was done electronically. In the process of transmittals, various reviews, and editorial handling, a few errors and omissions were created. The lists that follow contain the additions and corrections that have been brought to our attention. We have limited the corrections to matters of fact; small errors in spelling, punctuation, and formatting are not addressed. We apologize to the authors whose papers were mishandled in some manner.

The Editorial Team

Errata

Volume 1, Page 541

Cave Sediments Related to Cretaceous-Tertiary Paleokarst Developed in Eogenetic Carbonate Rocks: Examples from SW Slovenia and NW Croatia by Bojan Otoničar.

The abstract was truncated in printing with only the first few lines appearing in the Proceedings. The full abstract follows.

In the SW Slovenia and NW Croatia a regional paleokarstic surface separates the passive margin shallow-marine carbonate successions of different Cretaceous formations from the Upper Cretaceous to Eocene palustrine and shallow marine limestones of the synorogenic carbonate platform. Thus, the paleokarst corresponds to an uplifted peripheral foreland bulge, when diagenetically immature eogenetic carbonates were subaerially exposed and karstified.

Among the subsurface paleokarstic features vadose and phreatic forms are recognized. For the epikarst, pedogenic features and enlarged root related channels are characteristic. Vadose channels, shafts and pits penetrate up to a few tens of meters below the paleokarstic surface, where they may merge with originally horizontally oriented phreatic cavities. The latter comprise characteristics of caves forming in fresh/brackish water lenses. The phreatic cavities were found in different positions regarding to the paleokarstic surface, the lowest one being some 75 meters below it. Usually only one distinct paleocave level occurs per location, although indistinct levels of spongy porosity and/or irregularly dispersed cavities of different sizes have been noticed locally. The cavities had been subsequently partly reshaped and entirely filled with detrital sediments and flowstones in the upper part of the phreatic, epiphreatic and vadose zones. The internal cave sediments and flowstones may also occur as clasts in deposits (mostly breccias) that fill subsurface paleokarstic cavities and cover the paleokarstic surface. In general, the variety of cave infilling deposits and the amount of surface derived material decrease with the distance from the paleokarstic surface. Below the paleokarstic surface $\delta^{13}\text{C}$ and $\delta^{18}\text{O}$ values of cavity deposits usually exhibit good correlation with trend significant for meteoric diagenesis.

Relatively small phreatic cavities of the lowermost part of the paleokarstic profiles are commonly geopetally infilled with laminated mudstone derived from incomplete dissolution of the hostrock overlain by coarse grained blocky calcite of meteoric or mixing meteoric/marine origin. Somewhat larger phreatic caves located shallower below the paleokarstic surface usually exhibit more complicated stratigraphy. Although the lower parts of the caves are still mainly infilled with reddish stained micritic carbonate sediment, different types of flowstone, especially calcite rafts, become more prominent higher in the cave profiles. Gradually in the upper parts of the caves, sediments derived from the paleokarstic surface prevail over autochthonous deposits. Especially channels of the epikarst zone are almost entirely infilled with pedogenically modified material derived directly from the paleokarstic surface. Regardless of their origin, cave deposits had been often intensively modified by pedogenic processes while they were exposed to the paleokarstic surface by denudation. Just prior to marine transgression over the paleokarstic surface some cavities or their parts had been infilled by marine derived microturbidites. It will be shown that especially deposits related to denuded phreatic caves may be of great importance for the study of speleogenetic, geomorphologic and hydrogeologic evolution of a specific karst region.

Volume 2, page 650

Medical and Governmental Considerations of CO₂ and O₂ in Volcanic Caves by William R. Halliday

The final sentence of the first paragraph on page 652 contains incorrect wording. The sentence should read:

“The issue resurfaced when U.S. Geological Survey and National Park Service personnel applied OSHA standards to volunteers in volcanic caves with non-toxic levels of O₂ and CO₂.”

Volume 2, page 662

Unusual Rheogenic Caves of the 1919 “Postal Rift” Lava Flow, Kilauea Caldera, Hawaii by William R. Halliday

The first paragraph on page 664 contains several errors and misstatements. The corrected paragraph should read:

“Noxious gas (probably HCl) was encountered only in one tiny cave on the edge of Halemaumau Crater. Presumed sulfate fumes were encountered in numerous caves but were found to be essentially non-toxic. Eye irritation rarely was encountered (Halliday, 2000b). Two types of CO₂ monitors previously untested in volcanic caves were required for the last five field trips. They were found to be useless in hyperthermal caves and no significant elevation of CO₂ was identified in normothermic examples (Halliday, 2007). In no cave was significantly elevated CO₂ identified by changes in normal breathing (Halliday, this volume).”

Volume 2, Page 785

Symposium #11, **Speleogenesis in Regional Geological Evolution and Its Role in Karst Hydrogeology and Geomorphology** was arranged by Alexander Klimchouk and Arthur N. Palmer (not by John Mylroie and Angel Ginés as listed on the title page of the symposium in the Proceedings).

Volume 2, Page 1033

Uranium Mapping in Speleothems: Occurrence of Diagenesis, Detrital Contamination and Geochemical Consequences

The correct authors for this paper are: Richard Maire, Guillaume Deves, Ann-Sophie Perroux, Bassam Ghaleb, Benjamin Lans, Thomas Bacquart, Cyril Plaisir, Yves Quinif and Richard Ortega. The names of Bassam Ghaleb and Yves Quinif were omitted in the Proceedings Volume.

Volume 3, Page 1307

Species Limits, Phylogenetics, and Conservation of *Neoleptoneta* Spiders in Texas Caves by Joel Ledford, Pierre Paquin, and Charles Griswold

James Cokendolpher, Museum of Texas, Texas Tech University, Lubbock, Texas was also a co-author for this paper.

Omissions

The Fossil Bears of Southeast Alaska by Timothy H. Heaton and Frederick Grady was inadvertently omitted in the final stages of page layout. The reviewed and edited paper follows:

THE FOSSIL BEARS OF SOUTHEAST ALASKA

TIMOTHY H. HEATON¹, FREDERICK GRADY²

¹Department of Earth Sciences, University of South Dakota, Vermillion, SD, 57069, USA

²Department of Paleobiology, Smithsonian Institution, Washington, DC, 20560, USA

Southeast Alaska is home to brown bears (*Ursus arctos*) and black bears (*U. americanus*) with an unusual distribution. Both species inhabit the mainland, while only black bears inhabit the islands south of Frederick Sound and only brown bears inhabit the islands north of Frederick Sound. Brown bears of the northern islands belong to a distinct lineage and are genetically more similar to polar bears than their mainland counterparts. Bears are among the most common fossils found in caves in the region, and they indicate that both species made greater use of caves as dens when the climate was colder. But no bear fossils are known from the Last Glacial Maximum (LGM), even at On Your Knees Cave where foxes and marine mammals have been recovered across most of this interval. This begs the question of whether bears survived the LGM on coastal refugia or recolonized the islands after the ice retreated. No evidence has been found to settle the question for black bears. Black bears are far more common than brown bears in On Your Knees Cave for the period before the LGM, but they were slower than brown bears in expanding their range across the islands after the ice melted. The evidence for survival in a local refugium is much stronger for brown bears. While they are less common before the LGM, they had a greater distribution than black bears immediately following the LGM, including some of the outermost islands of the archipelago. The lack of brown bear fossils from mainland sites during early postglacial times may indicate that the mainland was not the source of this population. The distinct genetic character of modern island brown bears also suggests that they did not derive from the mainland. Two fossil brown bears from caves of Prince of Wales Island have had successful DNA extractions and match the distinct lineage that now lives only on the northern islands of Southeast Alaska. A refugium for brown bears may have been offshore on the continental shelf which was exposed during the LGM but was flooded by rising sea level in the early postglacial period.

1. Introduction

Our research in southeast Alaska began in 1991 after several bear skeletons were found in El Capitan Cave on Prince of Wales Island by a caving expedition (HEATON and GRADY, 1992, 1993). El Capitan Cave is Alaska's largest known cave and has passages that flood during storms, but the fossils were found in a quiet upper passage near the surface. One skeleton was complete and undisturbed, suggesting that the bears were denning in the cave, so cavers called this passage the Hibernaculum. It was apparent that the bears accessed the cave by an entrance that had become sealed with soil and logs, and we were able to reopen this entrance to conduct an excavation of the site. Soon cavers discovered skeletons in other caves of the region with similar dimensions, namely horizontal passages 1.5-2.5 meters in diameter. Several natural trap caves with bear fossils were also discovered. Although our research has expanded to include a variety of mammals, birds, and fishes (HEATON and GRADY, 2003), bears have remained a major focus, and our fossil discoveries have contributed to solving the question of whether animals survived the Ice Age in Southeast Alaska.

Most islands of Southeast Alaska are home to bears, but currently there is no more than one species per island. Black bears (*Ursus americanus*) inhabit Prince of Wales Island and most other islands south of Frederick Sound, while brown bears (*Ursus arctos*) inhabit the islands north of Frederick Sound, namely Admiralty, Baranof, and Chichagof (ABC) islands. Both species inhabit the nearby mainland (MACDONALD and COOK, 2007). Prior to the discovery of a fossil record, KLEIN (1965) proposed that this island distribution resulted from a postglacial colonization history: brown bears arriving from the north and black bears from the south. This hypothesis was based on the prevailing assumption that no land animals survived the Last Glacial Maximum (LGM, 24,000-13,000 radiocarbon years B.P.) in Southeast Alaska because of complete ice cover. Although the islands of Southeast Alaska exhibit a nested mammalian fauna suggestive of recent colonization (CONROY et al., 2000), fossil and genetic studies of bears have revealed a much more complex history in the region.

The complete skeleton from El Capitan Cave, as well as portions of several others, were of black bears, distinguished from the living bears on the island only by their large size. Their size seemed especially significant since they appeared to be females based on the lack of bacula and the gracile structure of their skulls. Even more significant was the discovery of even larger bear remains that we identified as brown bear. Finding that Prince of

Wales Island had been home to additional species in early postglacial time conflicted with the simple postglacial colonization model held by KLEIN (1965) and other biologists. In addition to brown bears, we also discovered fossil remains of Arctic fox (*Alopex lagopus*), red fox (*Vulpes vulpes*), and caribou (*Ranifer tarandus*) that no longer inhabit the island. Rather than lacking a fauna at the end of the Ice Age, Prince of Wales Island simply had a different fauna that was adapted to the colder and less forested habitat.

Following this initial discovery we set out to expand our dataset both geographically and chronologically by searching for caves with fossil deposits on different islands and the mainland, in diverse habitats, and of greater antiquity. During the 1990s fossil sites were brought to our attention by cavers exploring the region, often working with the support of Tongass National Forest and guided by forest agendas. After 2000 we began coordinating searches for caves specifically to fill in gaps in our dataset. In spite of limits imposed by limestone distribution and the difficulty of finding sites over 12,000 years old, a long history for both brown and black bears has emerged. During this same period geneticists began DNA studies on living bear populations in Southeast Alaska that complemented our work (HEATON et al., 1996), and we have worked in conjunction with ancient DNA researchers to trace bear lineages back in time. What has emerged is a greatly expanded, but not entirely complete, picture of bear history in Southeast Alaska.

2. Postglacial History

The postglacial record of bears in Southeast Alaska is spectacular. Following the discovery of black and brown bears in El Capitan Cave (130 m elevation), additional brown bear skeletons were found in two high elevation caves (over 500 m) on northern Prince of Wales Island: two juveniles in a natural trap called Blowing in the Wind Cave, and parts of 12 individuals in a horizontal tube called Bumper Cave, including skeletons of what appeared to be a mother and her two cubs (Table 1). By contrast, lower elevation caves (below 200 m) on the island, such as Kushtaka and On Your Knees caves (den sites) and Tlacatzinacantli Cave (a natural trap) contained only black bears from the postglacial interval (Table 2). This apparent partitioning of den sites by the two species must be kept in mind when considering other parts of Southeast Alaska where samples from diverse elevations are not available. This does not mean that brown bears were restricted to high elevations because their isotopic signature indicates a stronger marine diet than black bears (HEATON 1995; HEATON and GRADY, 2003).

Table 1. List of radiocarbon dated brown bear (*Ursus arctos*) fossils from caves of Southeast Alaska in order of age.

Laboratory #	Age (years B.P.)	$\delta^{13}\text{C}$	Site	Island	Sample
AA-15224	7,205 ± 65	-17.9	Bumper Cave	POW	Dentary
AA-56996	9,590 ± 95	-20.5	Deer Bone Cave	Coronation	Radius
AA-07794	9,760 ± 75	-18.0	El Capitan Cave	POW	Humerus
AA-10451	9,995 ± 95	-18.5	Blowing in the Wind Cave	POW	Ribs
AA-52223	10,700 ± 100	-17.1	Enigma Cave	Dall	Humerus
AA-15225	10,970 ± 85	-19.5	Bumper Cave	POW	Molar
AA-15223	11,225 ± 110	-16.8	Bumper Cave	POW	Humerus
AA-52221	11,600 ± 100	-14.6	Enigma Cave	Dall	Dentary
AA-44450	11,630 ± 120	-18.2	Colander Cave	Coronation	Humerus
AA-15222	11,640 ± 80	-17.8	Bumper Cave	POW	Rib
AA-15226	11,715 ± 120	-16.0	Enigma Cave	Dall	Humerus
AA-32122	11,910 ± 140	-18.1	El Capitan Cave	POW	Rib2
AA-52222	11,930 ± 120	-14.6	Enigma Cave	Dall	Skull
AA-10445	12,295 ± 120	-18.3	El Capitan Cave	POW	Pelvis
AA-33783	26,820 ± 700	-16.3	On Your Knees Cave	POW	Astragalus
AA-52219	29,040 ± 600	-16.3	On Your Knees Cave	POW	Rib
AA-52220	29,590 ± 980	-17.7	On Your Knees Cave	POW	M2/
AA-33792	31,700 ± 1900	-16.2	On Your Knees Cave	POW	Molar
AA-52218	31,900 ± 1,300	-19.6	On Your Knees Cave	POW	Claw
AA-52207	33,300 ± 1,500	-17.0	On Your Knees Cave	POW	Phalanx 1
AA-15227	35,365 ± 800	-15.9	On Your Knees Cave	POW	Femur
AA-52215	38,800 ± 3,000	-10.0	On Your Knees Cave	POW	Phalanx 2

AA-33791	39,400 ± 3100	-17.1	On Your Knees Cave	POW	Tooth
AA-52216	34,000 +	-17.4	On Your Knees Cave	POW	M/1
AA-52201	40,900 +	-16.8	On Your Knees Cave	POW	P4/
AA-52217	41,100 +	-15.4	On Your Knees Cave	POW	Vertebra

Table 2. List of radiocarbon dated black bear (*Ursus americanus*) fossils from caves of Southeast Alaska in order of age.

Laboratory #	Age (years B.P.)	δ¹³C	Site	Island	Sample
CAMS-27263	2,790 ± 60	-23.2	Kushtaka Cave	POW	Artifact
AA-57000	3,425 ± 50	-12.5	Lawyers Cave	Mainland	Humerus
CAMS-31068	3,960 ± 50	-20.7	On Your Knees Cave	POW	Dentary
AA-36637	4,847 ± 58	-21.2	Hole 52 Cave	Mainland	Skull
SR-5265	6,290 ± 50		Lawyers Cave	Mainland	Phalanx
AA-10447	6,415 ± 130	-22.1	El Capitan Cave	POW	Skull
CAMS-24967	8,630 ± 60	-21.4	Kushtaka Cave	POW	Rib
AA-18451R	9,330 ± 155	-23.9	Kushtaka Cave	POW	Femur
AA-32118	10,020 ± 110	-22.1	Tlacatzinacantli Cave	POW	Femur
AA-36641	10,080 ± 120	-21.6	Hole 52 Cave	Mainland	Phalanx
AA-33780	10,090 ± 160	-21.2	On Your Knees Cave	POW	Phalanx
CAMS-42381	10,300 ± 50	-20.7	On Your Knees Cave	POW	Artifact
AA-36636	10,350 ± 100	-18.9	Hole 52 Cave	Mainland	Skull
AA-36640	10,420 ± 110	-21.6	Hole 52 Cave	Mainland	Skull
AA-07793	10,745 ± 75	-21.1	El Capitan Cave	POW	Humerus
AA-32120	10,860 ± 120	-21.8	Tlacatzinacantli Cave	POW	Skull
AA-32117	10,870 ± 120	-21.8	Tlacatzinacantli Cave	POW	Ulna
AA-36638	10,930 ± 140	-19.8	Hole 52 Cave	Mainland	Skull
AA-32119	10,970 ± 120	-22.4	Tlacatzinacantli Cave	POW	Fragment
AA-33202	11,460 ± 130	-19.9	Hole 52 Cave	Mainland	Canine
AA-10446	11,540 ± 110	-20.0	El Capitan Cave	POW	Skull
AA-10448	11,565 ± 115	-18.7	El Capitan Cave	POW	Skull
AA-21569	28,695 ± 360	-20.7	On Your Knees Cave	POW	Calcaneum
AA-21570	29,820 ± 400	-20.8	On Your Knees Cave	POW	Vertebra
AA-33781	36,770 ± 2300	-18.6	On Your Knees Cave	POW	Femur
AA-33194	38,400 ± 3000	-18.4	On Your Knees Cave	POW	Humerus
AA-33198	39,000 ± 3100	-19.5	On Your Knees Cave	POW	Rib
AA-16831	41,600 ± 1500	-20.7	On Your Knees Cave	POW	Tibia
AA-36653	25,000 +	-22.0	On Your Knees Cave	POW	Premolar
AA-36655	27,000 +	-18.2	On Your Knees Cave	POW	Baculum
AA-33196	38,500 +	-19.4	On Your Knees Cave	POW	Scapula
AA-52206	38,500 +	-20.8	On Your Knees Cave	POW	Metapodial
AA-52204	39,100 +	-20.2	On Your Knees Cave	POW	Canine
AA-33200	39,400 +	-19.3	On Your Knees Cave	POW	Canine
AA-33195	40,100 +	-18.4	On Your Knees Cave	POW	Humerus
AA-33199	40,200 +	-19.9	On Your Knees Cave	POW	Canine
AA-44448	41,000 +	-21.7	On Your Knees Cave	POW	Molar
SR-5110	43,050 +		On Your Knees Cave	POW	Vertebra
SR-5111	44,940 +		On Your Knees Cave	POW	Skull

Several postglacial deposits have also been found on the mainland near the town of Wrangell and on two of the outermost islands of the Archipelago: Coronation and Dall Islands (HEATON and GRADY, 2003). Today only black bears inhabit Dall Island while no bears inhabit Coronation Island (MACDONALD and COOK, 2007). Three early postglacial cave deposits have turned up six individuals, all of which match brown bear (Table 1). Deer Bone Cave is a den cave while Colander Cave is a natural trap, and Enigma Cave is larger and more complex with bear skeletons both in horizontal den passages and at the bottom of pits. All these caves are at 200 m elevation or lower. By contrast, two postglacial cave deposits on the mainland, a den site called Lawyers Cave and a complex cave with horizontal passages and pits called Hole 52, contain only black bear remains (Table 2). Brown bears may have denned at higher elevation, but no such sites are known. The remarkable conclusion from these sites is that the two bear species had nearly the opposite distribution in the early postglacial period than they do today. Currently both species inhabit the mainland while only black bears inhabit the southern islands of Southeast Alaska. Shortly after the Ice Age only brown bears inhabited the outer islands, both species occupied the large Prince of Wales Island, and only black bears are documented from the mainland.

Discovering the postglacial history of bears in the northern islands of Southeast Alaska, where only brown bears live today, has been hampered by a paucity of limestone and a lack of any fossil discovery. Since brown bears thrived in the southern islands in early postglacial times, there is no reason to doubt their presence farther north. Whether black bears ever colonized the northern islands remains a mystery. To the south of Alaska a pattern similar to Prince of Wales Island has been documented by Canadian investigators. Haida Gwaii (Queen Charlotte Islands) and Vancouver Island are currently home only to black bears. Fossil black bears have been found dating back to 10,000 years B.P. on Haida Gwaii (RAMSEY et al., 2004; FEDJE et al., 2004) and from about 9,800 to 12,000 years B.P. on Vancouver Island (NAGORSEN et al., 1995; NAGORSEN and KEDDIE, 2000). Brown bears from Haida Gwaii have been found dating from 10,000 to 14,500 years B.P., showing that they once were widespread on coastal islands.

Another remarkable pattern visible in Tables 1 and 2 is the sheer number of early postglacial bears. With the exception of the sealed hibernaculum of El Capitan Cave, all of these sites remain open for potential denning today. Yet far more specimens of both black and brown bears date between 9,000 and 12,000 years B.P. than date to the 9,000 years since then. Most of these remains were exposed on the cave floors (not fully buried) so were not selected for dating based on their potential antiquity. Either bears were more numerous in early postglacial times or they were denning in caves much more regularly. The fact that natural trap caves (at least a third of the sites) show this same pattern suggests a high bear population. None of the other species we have studied show this distinct chronological pattern. Perhaps the early successional stages of forest development following the melting of the glaciers provided a high density of berries and other edible foods preferred by bears for the herbivorous part of their diet. Since climax forests are lacking in such foods, modern bears are attracted to forest clear-cuts, shorelines, and other disturbed areas where such plants grow.

3. Ice Age History

The single site in Southeast Alaska that has produced an extensive Ice Age record (prior to 13,000 radiocarbon years B.P.) is On Your Knees Cave. It is a small cave on the northern tip of Prince of Wales Island discovered during a logging survey and had only a few bones initially exposed. The significance of the site was only recognized when a partial brown bear femur was radiocarbon dated to 35,365 years B.P. (Table 1). Excavation began in 1996 and continued until 2004. An extensive record of mammals, birds, and fish was discovered covering at least the last 45,000 years (HEATON and GRADY, 2003) plus an extensive archaeological record including the oldest human remains from Alaska or Canada (DIXON et al., 1997). Devil's Canopy Cave on Prince of Wales Island is the only other site where we obtained an Ice Age radiocarbon date (on marmot), but extensive excavation produced only a few rodent and insectivore remains. Our extensive efforts to find an Ice Age site on the outer islands of Southeast Alaska have so far been unsuccessful.

For a single site, On Your Knees Cave provides a superb record of animals during the LGM and the preceding interstadial. As can be seen in Tables 1 and 2 many bone dates are beyond the radiocarbon limit, but uranium dates on speleothem fragments date back to $185,800 \pm 2,800$ years B.P. (DORALE et al., 2003). Both black and brown bears were present and probably used the cave as a den from at least 41,000 years B.P. until the approach of the LGM (Tables 1 and 2). We have not dated enough samples to be certain exactly when their use of the cave ceased, but no bear remains have been dated to the glacial maximum itself. A sample of 25 ringed seal (*Phoca hispida*) specimens were radiocarbon dated from $24,150 \pm 490$ to $13,690 \pm 240$ years B.P., which is the very interval that the

bears (and caribou) are missing. Arctic and red foxes, other marine mammals, and sea birds also date to the LGM, so the cave was available and used as a den (by foxes) during that interval. One ringed seal humerus has bite marks that match bear canines, but it could be a polar bear (*Ursus maritimus*) kill that was scavenged by foxes.

Black bear fossils outnumber brown bear fossils in On Your Knees Cave by a ratio of about 10:1. This is not evident in Tables 1 and 2 because we selected specimens of both species for dating. This difference could represent a greater abundance of black bears or a partitioning of den sites by elevation like we see during the postglacial period. Other elements of the fauna suggest that conditions during the interstadial were similar to the early postglacial interval before a climax forest was established.

4. Genetics

TALBOT and SHIELDS (1996) found that brown bears of Admiralty, Baranof, and Chichagof (ABC) islands (Southeast Alaskan islands north of Frederick Sound) are distinct from all other populations based on mitochondrial DNA and are more closely related to polar bears than to their mainland counterparts. Using nuclear microsatellite variations PAETKAU et al. (1998) confirmed this result for females but detected some exchange of males with the local mainland population. LEONARD et al. (2000) discovered a fossil from Yukon Territory matching the ABC bears and dating to $36,500 \pm 1,150$ years B.P., so this clade had a wider distribution before the LGM. Nevertheless, the current restricted range of this clade suggests that the islands of Southeast Alaska acted as a refugium for this population during the glacial maximum (HEATON et al., 1996). Further support for this hypothesis comes from early postglacial fossils of Prince of Wales Island and Haida Gwaii. After several failed attempts at extracting ancient DNA, BARNES et al. (2002) reported that a brown bear fossil from Blowing in the Wind Cave (AA-10451 on Table 1) belongs to the ABC clade. Further work by Sarah Bray (personal communication) also linked a bear from Bumper Cave (AA-16553 on Table 1) and ones from Haida Gwaii to the ABC clade.

STONE and COOK (2000) found that black bears from the southern islands of Southeast Alaska belong to a mitochondrial lineage that is also found on the islands and coastal mainland of British Columbia and down the coast to northern California. Several other mammal species have distinct coastal lineages with a similar range, but it remains unclear whether the source of these lineages was south of Cordilleran glaciers or on coastal refugia, possibly in Southeast Alaska (COOK et al., 2001, 2006).

5. Conclusions

The absence of a fossil record of bears from the LGM leaves open the question of whether they survived the glacial expansion in Southeast Alaska on coastal refugia or recolonized afterward. Cave faunas document that both brown and black bears were present during the preceding interstadial and reappeared in great numbers soon after the ice melted. Genetic evidence for a distinct coastal lineage, where refugial isolation is the simplest explanation, is strong for brown bears but more equivocal for black bears. Both bears are refugial species in the sense that they were adversely affected by glaciation and struggled to survive under unfavorable climatic conditions. By contrast, other carnivores such as ringed seals, Arctic foxes, and likely polar bears flourished and expanded their ranges during the LGM. The extent to which the Arctic and refugium faunas competed with one another is unknown, but their interactions could have been a factor in the temporary loss of black and brown bears from On Your Knees Cave.

What we learn from postglacial bears is that the species were able to move about freely and colonize territory that was favorable for them, rather than being restricted by barriers and competition. Solving the full puzzle of bear history in Southeast Alaska will require finding additional faunas of similar antiquity to On Your Knees Cave, as a single site cannot document the movements of species. During the LGM the expanding glaciers pushed mammal populations westward, while falling sea level opened up new habitat to the west and changed the configuration of the coastal corridor. The possibility that populations of bears and other mammals found suitable refugia to survive the LGM in Southeast Alaska is very possible.

References

- BARNES, I., P. MATHEUS, B. SHAPIRO, D. JENSEN, and A. COOPER (2002) Dynamics of Pleistocene population extinctions in Beringian brown bears. *Science* 295:2267–2270.
- CONROY, C. J., J. R. DEMBOSKI, and J. A. COOK (1999) Mammalian biogeography of the Alexander Archipelago of Alaska: a north temperate nested fauna. *Journal of Biogeography* 26:343–352.

- COOK, J. A., A. L. BIDLACK, C. J. CONROY, J. R. DEMBOSKI, M. A. FLEMING, A. M. RUNCK, K. D. STONE, and S. O. MACDONALD (2001) A phylogeographic perspective on endemism in the Alexander Archipelago of the North Pacific. *Biological Conservation* 97:215-227.
- COOK, J. A., N. G. DAWSON, and S. O. MACDONALD (2006) Conservation of highly fragmented systems: The north temperate Alexander Archipelago. *Biological Conservation* 133:1-15.
- DIXON, E. J., T. H. HEATON, T. E. FIFIELD, T. D. HAMILTON, D. E. PUTNAM, and F. GRADY (1997) Late Quaternary regional geoarchaeology of Southeast Alaska karst: A progress report. *Geoarchaeology* 12(6):689-712.
- DORALE, J. A., T. H. HEATON, and R. L. EDWARDS (2003) U-Th dating of fossil-associated cave calcites from southeastern Alaska. *Geological Society of America Abstracts with Programs*, vol. 35, no. 6, p. 334.
- FEDJE, D. W., Q. MACKIE, E. J. DIXON, and T. H. HEATON (2004) Late Wisconsin environments and archaeological visibility on the northern Northwest Coast. In *Entering America: Northeast Asia and Beringia before the Last Glacial Maximum*, D. B. Madsen (ed.), University of Utah Press, p. 97-138.
- HEATON, T. H. (1995) Interpretation of $\delta^{13}\text{C}$ values from vertebrate remains of the Alexander Archipelago, southeast Alaska. *Current Research in the Pleistocene*, vol. 12, pp. 95-97.
- HEATON, T. H., and F. GRADY (1992) Preliminary report on the fossil bears of El Capitan Cave, Prince of Wales Island, Alaska. *Current Research in the Pleistocene* 9:97-99.
- HEATON, T. H., and F. GRADY (1993) Fossil grizzly bears (*Ursus arctos*) from Prince of Wales Island, Alaska, offer new insights into animal dispersal, interspecific competition, and age of deglaciation. *Current Research in the Pleistocene* 10:98-100.
- HEATON, T. H., and F. GRADY (2003) The Late Wisconsin vertebrate history of Prince of Wales Island, Southeast Alaska. In *Ice Age Cave Faunas of North America*, B. W. Schubert, J. I. Mead, and R. W. Graham (eds.), Indiana University Press, p. 17-53.
- HEATON, T. H., S. L. TALBOT, and G. F. SHIELDS (1996) An Ice Age Refugium for Large Mammals in the Alexander Archipelago, Southeastern Alaska. *Quaternary Research*, 46(2):186-192.
- KLEIN, D. R. (1965) Postglacial distribution patterns of mammals in the southern coastal regions of Alaska. *Arctic* 18:7-20.
- LEONARD, J. A., R. K. WAYNE, and A. COOPER (2000) Population genetics of Ice Age brown bears. *Proceedings of the National Academy of Sciences* 97(4):1651-1654.
- MACDONALD, S. O., and J. A. COOK (2007) Mammals and amphibians of Southeast Alaska. *Museum of Southwestern Biology Special Publication* 8:1-191.
- NAGORSEN, D. W., and G. KEDDIE (2000) Late Pleistocene Mountain Goats (*Oreamnos Americanus*) From Vancouver Island: biogeographic Implications. *Journal of Mammalogy* 81(3): 666-675.
- NAGORSEN, D. W., G. KEDDIE, and R. J. HEBDA (1995) Early Holocene black bears, *Ursus americanus*, from Vancouver Island. *Canadian Field-Naturalist* 109(1):11-18.
- PAETKAU, D., G. F. SHIELDS, and C. STROBECK (1998) Gene flow between insular, coastal and interior populations of brown bears in Alaska. *Molecular Ecology* 7:1283-1292.
- RAMSEY, C. L., P. A. GRIFFITHS, D. W. FEDJE, R. J. WIGEN, and Q. MACKIE (2004) Preliminary investigation of a late Wisconsinan fauna from K1 cave, Queen Charlotte Islands (Haida Gwaii), Canada. *Quaternary Research* 62(1):105-109.
- STONE, K. D., and J. A. COOK (2000) Phylogeography of black bears (*Ursus americanus*) of the Pacific Northwest. *Canadian Journal of Zoology* 78:1218-1223.
- TALBOT, S. L., and G. F. SHIELDS (1996) Phylogeography of brown bears (*Ursus arctos*) of Alaska and paraphyly within the Ursidae. *Molecular Phylogenetics and Evolution* 5:477-494.

TABLE OF CONTENTS

Preface 17**Plenary Lectures 19**

An up to date report on cave exploration around the world. Andy Eavis. 21

State of the art in the speleological sciences. Paolo Forti. 26

UIS – The organization of international speleology. Jose Ayrton Lebegalini. 32

UNESCO World Heritage caves and karst: Present situation, future prospects and management requirements. Paul Williams. 38

Symposium 1. Archaeology and Paleontology in Caves 45

Mgharet Al-Hourriye: A speleo-archaeological project. Hani Abdul-Nour, Samer Amhaz, Lorine Mouawad, Badr Jabbour-Gedeon. 47

A dendroarchaeological approach to understanding the nineteenth century saltpetre-mining industry in the southeastern United States. Sarah A. Blankenship, Henri D. Grissino-Mayer. 51

Heart of the Earth, heart of the community: The role of caves in the validation of settlement space. James E Brady, Ann M. Scott. 58

New researches in a famous karst area: The cradle of humankind (Gauteng, South Africa). Laurent Bruxelles, Jose Braga, Francis Durathon, Francis Thackeray. 64

The contribution of cavers to the development of Maya cave archaeology. Allan Cobb, James E. Brady. 69

Mortuary caves and sinkholes in the interior low plateaus and southern Appalachian Mountains in the eastern United States. G. Crothers, P. Willey. 74

Late Pleistocene to historic vertebrate faunas from caves and karst features at Camp Bullis, Texas. David Froehlich, Laura Froehlich, Rickard Toomey, George Veni. 80

Fossil mammals from Island Ford Cave, Virginia, USA. Fred Grady, David A. Hubbard Jr. 86

Rock art and other archeological cave use on the North American plains from Canada to northern Mexico. John Greer, Mavis Greer. 90

Speleo-archaeology in Papua New Guinea: The discovery of paleolithic flint mines on the shores of the Soloman Sea. Roman Hapka. 97

Sand blasting as an archaeological restoration tool in caves. Ray Keeler. 105

Contributions of Edwards Plateau cave deposits to Pleistocene vertebrate paleontology. Ernest L. Lundelius Jr. 106

Identifying prehistoric trackways using stride lengths: Behavioral inferences from Jaguar Cave, Tennessee. Kyle McCormick. 110

The significance of cave bears for passage morphology. Lukas Plan, Doris Döppes, Thomas Wagner. 116

A new tool-type from the upper stratigraphic layers of Petralona Cave. Dr Nikos A. Poulianos. 117

Combined new paleoclimatologic and chronologic evidence from Petralona Cave. Nikos Poulianos, Athanasios Koutavas, Xianfeng Wang, Larry Edwards, Aris Poulianos. 121

Texas caves: Texas ossuaries. Ron Ralph. 122

Geoarchaeological characterization of rock shelters in a karst context in Minas Gerais (Brazil). Maria Jacqueline Rodet, Joël Rodet. 129

Prehistoric cave art in southeastern North America. Jan F. Simek, Alan Cressler. 135

Application of U-series dating method to fossil bones: new perspectives. Grzegorz Sujka, Helena Hercman. 140

The importance of karst sites as paleontological localities. Rickard S. Toomey III. 141

Graffiti in the Melidoni Cave in Crete, Greece. Yannis Z. Tzifopoulos, Nikos Litinas. 142

The world of the past in the world underground. Patty Jo Watson. 147

Archaeology in Brazilian caves. Leandro A.F., Xavier, Divaldo R. Sampaio. 153

Symposium 2. Educating Citizens about Living in Karst 159

Karst education in Western Australia. Jay Anderson. 161

Cave environmental education: The Greek example. Konstantina Aretaki. 165

- School didactics on caves and caving in Italy. Giovanni Badino, Daniele Berardi, Simona Bonardi, Giampiero Marchesi, Marco Ottalevi, Chiara Silvestro. 171
- Guatemala show caves participative diagnostic. Ferdinando Didonna, Lucrecia Gordillo, Nancy Mollinedo, Andres Ulloa. 174
- Exploring karst in Google Earth: A tool for education and sharing information. Katarina Z. Doctor, Daniel H. Doctor. 181
- Proyecto Bellamar. Esteban Grau González-Quevedo, Ivonne Vázquez de la Torre. 184
- US/Chinese efforts in water resource development in southwest China's karst regions through education. Chris Groves, Yuan Daoxian, Jennifer Turner. 185
- Say, what's a cave? Dis, qu'est-ce qu'une grotte? Badr Jabbour-Gedeon, Ghada Salem, Maya Chehab, Sara Zoghbi, Helene Richmany. 186
- Learning package for teachers about caves and karst. Pierre-Yves Jeannin, Urs Eichenberger. 191
- Training, outreach, and exploration in the East Mountain Plateau, Mengzi County, Yunnan Province, China. Patricia Kambesis, Chris Groves. 192
- Flying the flag for karst and geodiversity in NSW, Australia. Stephen F Meehan. 193
- Lidar-3-D photo real modeling of Devils Sinkhole in Rocksprings, Texas. Bobbie Neubert, J.A. Bellian, Xueming Xu, Kevin McGowan, Geary M. Schindel, E. Calvin Alexander Jr. 197
- The Devils Sinkhole Lidar Project, Edwards County, Texas, USA. Geary Schindel, Allan B. Cobb, Travis Scott, Randy Rosales. 198
- IDEC: An imagery data extraction collaborative and education tool for cave and karst. Jessica R. Snider, Diana E. Northup, Johann Van Reenen, M. Alex Baker, Christy Crowley, Brian Freels-Stendel, Jennifer J.M. Hathway, Linn Marks Collins, Mark L.B. Martinez, James E. Powell. 199
- The Project Underground education program. Carol Zokaites. 205
- The Virginia karst education program. Carol Zokaites, Wil Orndorff. 209

Symposium 3. Evolution and Ecology of Salamanders in Karst 217

- The biogeography and rapid radiation of central Texas Neotenic salamanders. Nathan F. Bendik, Andrew G. Gluesenkamp, Paul T. Chippindale. 219
- Biogeography and evolution of subterranean salamanders. Ronald M. Bonett, Danté Fenolio. 226
- Texas cave and spring salamanders (*Eurycea*): New discoveries and new surprises. Paul T. Chippindale, Andrew G. Gluesenkamp, Nathan F. Bendik. 227
- Sampling elusive species in karst environments: Design and demographic modeling considerations. Bret A. Collier, Danté B. Fenolio. 228
- Recent findings about the biology, ecology, and systematics of the grotto salamander, *Eurycea spelaea*. Danté Fenolio, Ronald Bonett. 234
- Salamanders of the genus *Eurycea* at Camp Bullis, Bexar County, Texas. Krista McDermid, Andrew Gluesenkamp. 238
- Systematics and evolutionary history of subterranean *Gyrinophilus* salamanders. Matthew L. Niemiller, Brian T. Miller, Benjamin M. Fitzpatrick. 242
- A survey of the cave-associated herpetofauna of the eastern United States with an emphasis on salamanders. Matthew L. Niemiller, Brian T. Miller. 249
- Recent records of epigeal salamanders (genus *Eurycea*) from central Texas springs. Chad W. Norris. 257
- Estimation of Jollyville Plateau salamander (*Eurycea tonkawae*) populations using surface counts and mark-recapture. Lisa O'Donnell, Andy Gluesenkamp. 264
- Behavioral ecology of aquatic salamanders colonizing subterranean habitats. Jakob Parzefall. 270

Symposium 4. Frontiers in Cave Mineralogy Studies 275

- Cryomineral formations from Koungur Ice Cave (Russia). Viacheslav N. Andreychouk. 277
- The Naica project. Tullio Bernabei, Giuseppe Casagrande, Alicia Davila, Antonio de Vivo, Antonieta Ferreira, Giuseppe Giovine, Gonzalo Infante, Francesco Lo Mastro. 283
- Isotopic study of nitrates from Upper Mississippi Valley saltpetre caves. Greg Brick, E. Calvin Alexander Jr, Daniel H. Doctor. 289
- Measurement of relative humidity in caves. Robert H. Buecher. 294
- Cave mineral database: A joint collaboration between geologists, librarians, and programmers. Beverly Caggiano, Bogdan P.

- Onac, Todd Chavez. 295
- Halite macrocrystalline stalactites of the Atacama caves (Chile). Jo De Waele, Paolo Forti, Vincenzo Picotti, Luca Zini. 296
- Minerogenesis in the Naica Caves (Chihuahua, Mexico) Paolo Forti, Ermanno Galli, Antonio Rossi. 300
- Isotopic investigations on gypsum deposits from caves in central Italy. Marco Menichetti, Mirona Ioana Chirienco, Bogdan P. Onac, Simon Bottrell. 306
- Preliminary data on mineralogical aspects of cave rims and vents in Cova des Pas de Vallgornera, Mallorca. Antoni Merino, Joan J. Fornós, Bogdan P. Onac. 307
- Mineralogy of chemical deposits in hypogenic Phiseua Cave, Khammouane, Central Laos Claude Mouret, Philippe Lapointe. 312
- Mineralogical and stable isotope investigations of minerals from caves on Cerna Valley (Romania). Bogdan P. Onac, Jonathan Sumrall, Tudor Tămaș, Cristina Cizmaș, Veronica Dârmiceanu, Ioan Povară, Lucian Nicolită. 318
- Cioclovina Cave (Romania): A unique mineralogical setting. Bogdan P. Onac, Herta S. Effenberger, Radu C. Breban, Joe B. Kearns. 324
- Mineral diversity in caves from Mallorca Island, Spain. Bogdan P. Onac, Joan J. Fornós, Àngel Ginés, Joaquin Ginés, Glen Hunt, Antoni Merino. 325
- Describing the microstructure of a soda straw. Victor J. Polyak, Paula P. Provencio. 326
- Which features of the cave environment control the growth of speleothems? Charles Self. 332
- Speleosol: A subterranean soil. Michael N. Spilde, Ara Kooser, Penelope J. Boston, Diana E. Northup. 338
- Venezuelan cave minerals: Second review. Franco Urbani. 345
- Speleothem ontogeny: Lessons from crystal growth theory and technology. William B. White. 346

Symposium 5. Geomicrobiology of Cave and Karst Environments 349

- Iron-manganese colonies of microorganisms from Zoloushka Cave (Ukraine). Viacheslav Andreychouk. 351
- Atacama Desert caves: Analogues for possible microbial life habitats on Mars. A. Azúa-Bustos, C. Gonzáles, R. Mancilla-Villalobos, L. Salas, J. Zúñoga. R. Vicuña. 352
- Mathematical modeling of biological and physical processes in complex mazelike cave biomats and desert crusts. P.J. Boston, J. Curnutt, E. Gomez, K.E. Schubert, D.E. Northup, H. Sun, C.P. McKay, A. Rinehart. 353
- Tracing the origins of chromophoric dissolved organic matter in karst aquifers. Kathleen M. Brannen, Annette Summers Engel, Justin E. Birdwell. 354
- Iron (III) bio-mineralization and its significance in Odyssey Cave, Bungonia, New South Wales, Australia. Annalisa K. Contos, Julia M. James. 360
- Evidence of ammonia oxidizing archaeal community in the Gruta da Caridade, Rio Grande do Norte State, Brazil. Marcelo Augusto De Freitas Kramer, Lucymara Fassarela Agnez-Lima. 362
- Discovering new diversity in Hawaiian lava tube microbial mats. Matthew G. Garcia, Monica Moya, Michael N. Spilde, Fred D. Stone, Diana E. Northup. 364
- Aqueous geochemical environments of Systema Zacatón, Mexico. Marcus O. Gary, Jason Sahl, Philip C. Bennett, John Spear, John M. Sharp, Jr. 370
- Microbial community energetics in Roraima Sur Cave, Venezuela. J. Giarrizzo, P. Suarez, B. Muench, M. Broering, E Banks, K. Venkateswaran, H.A. Barton. 372
- Microbial activity in the removal of xenobiotic compounds from karst aquifers. B. Iker, B. Lubbers, P. Kambesis, H.A. Barton. 375
- Microbially induced calcitic moonmilk deposits lead to inhibition of microbial activity in caves. I. Janices, M.C. Portillo, S. Cuezva, J.M. Gonzalez, J.C. Cañaveras, S. Sanchez-Moral. 378
- Biodiversity and biogeography of extremely acidic sulfidic cave snottites. D.S. Jones, J.L. Macalady. 381
- What can molecular microbiology tell us about Lascaux Cave? V. Jurado, F. Bastian, C. Alabouvette, C. Saiz-Jimenez. 384
- Microbial diversity in Kartchner Caverns, a carbonate cave in southern Arizona, USA. Antje Legatzki, Marian Ortiz, Julia W. Neilson, Matt Creamer, Karis Nelson, Hanh Th. Chu, Codie E. Banczak, Barry M. Pryor, Leland S. Pierson III, Raina M. Maier, Michael J. Vaughan, Robert R. Casavant, Rickard S. Toomey. 389
- Sulfur-oxidizing extremophiles from the caves of Acquasanta Terme, Italy. J.L. Macalady, D.S. Jones, D. Tobler, I. Schaperdoth, S. Galdenzi, M. Mainiero. 392
- The hunt for the hidden biodiversity of sulfidic caves: A case study of unique chloroflexi affiliated species and other novel species from Lower Kane Cave, Wyoming, USA. Daniela B. Meisinger, Annette Summers Engel, Megan L. Porter, Michael Schmid, Stefan Spring, Natuschka M. Lee. 395

- The geology of cave pools: Clues for the microbiology. L.A. Melim, D. Gustafson, A. Kooser, D.E. Northup, M.N. Spilde. 397
- Microbial diversity from the sulfidic karst spring, Žveplenica-Dolenja Trebuša, Slovenia. Janez Mulec, Annette Summers Engel, Andreea Oarga, Karen Rossmassler, Barbara J. Campbell, Stanka Šebela. 399
- Comparison of three moonmilk cave habitats associated with troglobitic beetles. M.G. Paoletti, M. Beggio, A. Pamio, T. Gomiero, M. Brilli, A.L. Dreon, V. Toniello, A.S. Engel. 400
- Energy flow and productivity-diversity relationships in chemolithoautotrophically-based ecosystems. Megan L. Porter, Annette Summers Engel. 404
- Microorganisms involved in the formation and dissolution of carbonate deposits in Spanish Caves. M.C. Portillo, E. Porca, S. Cuezva, S. Sanchez-Moral, J.M. Gonzalez. 406
- An autonomous robotic exploration of deep phreatic sinkholes reveals a wealth of microbial diversity. Jason W. Sahl, J. Kirk Harris, Marcus O. Gary, Bill Stone, John R. Spear. 408
- The control of a fungal outbreak in a show cave. Cesareo Saiz-Jimenez, Valme Jurado, Estefania Porca, Soledad Cuezva, Angel Fernandez-Cortes, Sergio Sanchez-Moral. 410
- How can buffered vadose and phreatic water dissolve CaCO_3 and form caves: A bacterial answer. Stephanie Schwabe, James L. Carew. 413
- Investigation of bacterioplankton communities in aquatic karst pools in Bärenschacht Cave of Bernese Oberland. Tatiana Shabarova, Jakob Pernthaler. 416

Symposium 6. Inventory of Cave and Karst Resources 423

- Karst potential index: A tool for mapping karst at the regional scale. James C. Currens, Randall L. Paylor, Matthew M. Crawford. 425
- Troggle: A novel system for cave exploration information management. Aaron Curtis. 431
- Cave inventory situation in Central America. Ferdinando Didonna, Carlos Goicoechea, Gustavo Quesada, Andres Ulloa. 437
- Creation of an international digital karst database and an interactive worldwide map of karst. Emily Hollingsworth, Van Brahana, Ethan Inlander, Michael E. Slay. 442
- The work of the UIS Informatics Commission. Peter Matthews. 447
- Examples of UIS Informatics Commission work. Peter Matthews. 451
- The Texas Speleological Survey: 48 years of data gathering. Ron Ralph. 452
- A new karst map of the United States. David J. Weary, Daniel H. Doctor. 457

Symposium 7. Island Karst 461

- On the origin of dissolution pipes. Jo De Waele, Stein-Erik Lauritzen, Mario Parise. 463
- Speleogenesis of extensive underwater caves along the Gulf of Orosei (center-east Sardinia, Italy). Jo De Waele, Markus Schafheutle, Thorsten Waelde. 469
- Mechanism of salt contamination of karstic springs related to the Messinian deep stage: The speleological model of Port Miou (France). Eric Gilli, Thomas Cavalera. 475
- About the genesis of an exceptional costal cave from Mallorca Island (western Mediterranean). The lithological control over the pattern and morphology of Cova des Pas de Vallgornera. Joaquín Ginés, Angel Ginés, Joan J. Fornós, Antoni Merino, Francesc Gràcia. 481
- Cave surveying and cave patterns in the southeastern coastal karst of Mallorca Island (Spain). Angel Ginés, Joaquín Ginés, Francesc Gràcia, Joan J. Fornós. 488
- Corrosion patterns related to meteoric-marine mixing zone in coastal cave systems of Mallorca Island (western Mediterranean). Francesc Gràcia, Joan J. Fornós, Antoni Merino. 496
- Environmental features, copepod taxonomic diversity and distribution patterns in coastal caves on Mallorca Island, Spain. S. Iepure, A. Ginés, F. Fiers. 501
- Coastal karst of Caguanes National Park, Sancti Spiritus, Cuba. Patricia Kambesis, Paul Berger, Mike Lace, Joel Despain. 502
- Coastal speleogenesis in Puerto Rico. Michael J. Lace, Patricia N. Kambesis. 509
- Geomorphic and archeological features of coastal caves in Madre de Dios Archipelago (Patagonia, Chile). Richard Maire, Bernard Tourte, Stéphane Jaillot, Joel Despain, Benjamin Lans, Franck Brehier, Luc-Henri Fage, Laurent Marc Pouilly

- Morel, Thibault Datry, Marc Massault, Dominique Genty, Christophe Moreau, Karine Wainer, Vincent Willy Dabin Ridoux, Jean-Francois Pernette, Marcelo Agüero Faridoni, Maria-Jose Manneschi. 516
- Cova des Pas de Vallgornera: An exceptional littoral cave from Mallorca Island (Spain). Antoni Merino, Antoni Mulet, Guillem Mulet, Antoni Croix, Francesc Gràcia. 522
- Effects of continental overprinting on cave development in eogenetic karst: An example from the Florida-Bahamas Platform. Paul J Moore. 528
- Flank margin cave development as syndepositional caves: Examples from the Bahamas. John E. Mylroie, Joan R. Mylroie. 533
- New minerals in caves from San Salvador Island, Bahamas. Bogdan P. Onac, Jonathan Sumrall, John E. Mylroie, Joe B. Kearns. 540
- Cave sediments related to Cretaceous – Tertiary paleokarst developed in eugenetic carbonate rocks: Examples from SW Slovenia and NW Croatia. Bojan Otoničar. 541
- Eogenetic karst of the carbonate islands of the northern Marianas. Kevin W. Stafford, John W. Jenson, John E. Mylroie. 542
- Coastal discharge features from an uplifted carbonate island aquifer: northern Guam, Mariana Islands. Danko Taboroši, John W. Jenson, John M.U. Jocson, John E. Mylroie. 548
- Precipitation of phreatic overgrowths at the water table of meteoric-marine mixing zones in coastal cave systems: A useful tool in sea level change reconstruction.. Paola Tuccimei, Michele Soligo, Joan J. Fornós, Angel Ginés, Joaquin Ginés, Bogdan P. Onac, Igor M. Villa. 554
- Speleogenesis in Cenozoic limestones on a passive continental margin: southeastern Australia. Susan White. 561

Symposium 8. Latest Advances in Karst Geophysics 569

- Discrimination between caves, overhangs, and large vugs using long-wave infrared imaging. Barbara Anne Am Ende. 571
- Detection of sub-travertine lakes using electrical resistivity imaging, Sistema Zacatón, Mexico. Marcus O. Gary, Todd Halihan, John M. Sharp Jr. 575
- Characterizing spring drainage areas using MODFLOW-DCM, a conduit/diffuse flow modeling tool. Ronald Green, Scott Painter, James Winterle. 580
- Mapping of karst solutional features using remote sensor technology. Josua D.Kenney, J, Gregory C. Willden, Ronald N. McGinnis, Ben A. Abbott, Ronald T. Green. 581
- The distribution rule of paleo-karst collapse pillars in northern China and their new exploration methods. He Keqiang, Lu Yaoru. 586
- Karst instrumentation to study site effect examples in Choranche Cave (France) and Madre de Dios Archipelago (Chile). L. Morel, Stephane Jaillet, Anne Sophie Perroux, Jan-Jacques Delannoy, Yves Perrette, Vincent Lignier, Emmanuel Malet, Richard Maire, Ultima Patagonia 2008. 591
- Characterization of karst solutional features using high-resolution electrical resistivity surveys. James Prikryl, Ronald McGinnis, Ronald Green. 597
- Paleomagnetism and magnetostratigraphy of cave sediments in Slovenia. Petr Pruner, Pavel Bosák, Nadja Zupan Hajna, Andrej Mihevc. 603
- Geophysical prospecting for a major spring conduit in the Ozark karst system (Missouri, USA) using audio-magnetotelluric (AMT) soundings. David J. Weary, Herbert A. Pierce. 604
- Electrical resistivity imaging and synthetic modeling of an inferred collapse structure – Inner Space Caverns, Texas, USA. Blake Weissling. 611
- Towards an positioning system for the subterranean world (U-GPS). Ramy Wenger, Pierre-Yves Jeannin. 612

Symposium 9. Lava Caves 619

- The ancient spring: Water in the land of fire. Edoardo Bellocchi. 621
- Pahoehoe and lava tubes in Payunia, North Patagonia, Argentina. Carlos Benedetto. 625
- Exploration of Manu Nui Lava Tube, Hawai'i, USA. Ann Bosted, Peter Bosted. 629
- Some aspects of speleogenesis in extraterrestrial environments: 1-Mercury and Mars. Vittorio Castellani, Arrigo A. Cigna. 634
- Some aspects of speleogenesis in extraterrestrial environment: 2-Moon and Venus. Vittorio Castellani, Arrigo A. Cigna. 640
- High precision U/Th dating of recent lava flows using syngenetic non-silicate cave minerals. Julian Dillon, Victor Polyak, Yemane Asmerom. 645
- Medical and governmental considerations of CO₂ and O₂ in volcanic caves. William R Halliday. 650
- A steeply inclined Pliocene (?) lava tube cave in Death Valley National Park, California. William R Halliday. David Ek. 653

- Mineral-lined thermal erosion channels in a hollow tumulus complex, Kilauea Caldera, Hawaii, USA. William R Halliday. 657
- Unusual rheogenic caves of the 1919 "Postal Rift" lava flow, Kilauea Caldera, Hawaii. William R. Halliday. 662
- Principles of pyroduct (lava tunnel) formation. Stephan Kempe. 668
- Interpreting the genesis of Thurston Lava Cave, Kilauea, Hawai`i. Stephan Kempe, Horst-Volker Henschel. 675
- Archaeology and ¹⁴C dates of the Kamakalepo/Waipouli/Stonehenge area, Nahalehu, Hawai`i. Stephan Kempe, Horst-Volker Henschel, Harry Schick, Basil Hansen. 682
- Jordanian lava caves and their importance to understand lava plateaus. Stephan Kempe, Ahmad Al-Malabeh, Horst-Volker Henschel. 690
- Possible lava tube development in the San Luis Valley and southeastern San Juan Mountains, Colorado. Douglas Medville. 698
- Seventeen years beneath Hualalai: A summary of caving experience. Douglas and Hazel Medville, Peter and Ann Bosted, Don Coons, Dave Bunnell, Nevin and Judy Davis, Bob Richards, John Rosenfeld, Steve Smith, Bernard and Sandy Szukalski. 703
- Composition of bacterial mats in El Malpais National Monument, New Mexico, USA: Comparison and contrasts with bacterial communities in Hawai`i lava tubes. Monica Moya, Matthew G. Garcia, Michael N. Spilde, Diana E. Northup. 709
- Umm Jirsan: Arabia's longest lava-tube system. John J. Pint. 714
- Identification of the microbial communities associated with roots in lava tubes in New Mexico and Hawaii. Jessica R. Snider, Monica Moya, Matthew G. Garcia, Michael N. Spilde, Diana E. Northup. 718
- As-Suwayda lava caves (southern Syria): speleological study combining geology and history. Johnny W. Tawk, Fadi H. Nader, Sami Karkabi, Waleed Jad. 724

Symposium 10. Protection and Management of Rare and Endangered Subterranean Fauna 731

- Gating a cave protects a bat colony...eventually. Debbie C. Buecher, Andrea K. Goodbar. 733
- Regional habitat conservation planning in karst terrain, Williamson County, Texas, USA. S.W. Carothers, K. White, G.L. Galbraith, G.D. Boyd. 738
- Inciting public interest and professional partnerships in the inventorying and monitoring of cave invertebrates, Kartchner Caverns State Park. Robert Casavant, Steve Willsey, Steve Casper, Supapan Seraphin. 739
- The role of karst fauna areas in the advancement of karst conservation in central Texas. C. Clover Clamons, P.G. Pierre Paquin. 740
- Speleothems and living organisms: What kind of relationship? Paolo Forti. 741
- Conservation and management of the Brazilian free-tailed bat: Colony size and activity patterns using thermal imaging. Nikolay I. Hristov, Margrit Betke, Thomas H. Kunz. 748
- Biogeographical distribution of subterranean fauna in Apulia (Italy), in the context of the paleo-geographical evolution of the area. Salvatore Inguscio, Emanuela Rossi, Mario Parise. 749
- Detection probabilities of karst invertebrates in central Texas. Jean K. Krejca, Butch Weckerly. 755
- Bats: going...going...gone with the wind Thomas H. Kunz, Edward R. Arnett. 760
- Cave animals in show caves in Slovenia. Andrej Mihevc. 761
- On rarity and the vulnerability of subterranean fauna. Oana Teodora Moldovan. 762
- Cave microbial communities: Is protection necessary and possible? Diana E. Northup. 763
- Management of endangered karst invertebrates on the Balcones Canyonlands Preserve, Austin, Texas. Kathleen M. O'Connor, Mark Sanders, Paul Fushille. 768
- Conservation of species on the wrong track? Is conservation of species losing its way? Boris Sket, Franci Gabrovšek. 769
- Karst invertebrate habitat and the role of excavation. Peter Sprouse, Jean Krejca. 770
- Karst landscape evolution: Impacts on speciation, biogeography, and protection of rare and endangered species. George Veni. 771
- Preserve design for endangered karst invertebrates in Bexar County, Texas. Cynthia A. Watson. 777
- Phylogeographic modeling of the Edwards Aquifer karst as a management tool for rare and endangered species in central Texas: A case study using troglobitic *Cicurina* spiders. K. White, P. Paquin. 783

Symposium 11. Speleogenesis in Regional Geological Evolution and Its Role in Karst Hydrogeology and Geomorphology 785

- Origin and development of the Dam-Valley Lakes and related karst hydrogeologic systems: Amtkeli River (western Caucasus). G.N. Amelichev, B.A. Vakhrushev, V.N. Dublyanskiy. 787

- Base level rise and *per ascensum* model of speleogenesis (PAMS). Interpretation of deep phreatic karst, Vaucluse springs and chimney-shafts. Philippe Audra, Ludovic Mocochain, Jean-Yves Bigot. 788
- The pattern of hypogenic caves. Philippe Audra, Ludovic Mocochain, Jean-Yves Bigot, Jean-Claude Nobecourt. 795
- Morphology and genesis of caves in iron-rich rocks. Augusto Auler, Luís B. Piló. 801
- The alkali speleogenesis of Roraima Sur Cave, Venezuela. Hazel A. Barton, Paula Suarez, Brittany Muench, Juan Giarrizzo, Mark Broering, Eric Banks, Kathhuri Venkateswaran. 802
- Relations between speleogenesis and surface morphogenesis of an exhumed karst plain (the Slunj Karst Plain, Dinaric Karst, Croatia). Neven Bočić. 808
- How can ghost rocks help in karst development. Laurent Bruxelles, Yves Quinif, Michel Wiéin. 814
- Evolution of Portuguese karst regions in a basin-inversion setting: Importance of faulting and confinement on cave development and spring locations. José António Crispim. 819
- Age of caves in the Cordillera de la Sal (Atacama, Chile) Jo De Waele, Vincenzo Picotti, Paolo Forti, George Brook, Cucchi Franco, Zini Luca. 825
- Kraushöhle (Austria): Morphology and mineralogy of an alpine sulfuric acid cave. Jo De Waele, Lukas Plan, Philippe Audra, Antonio Rossi, Christoph Spötl, Victor Polyak, Bill McIntosh. 831
- The age of cave systems in central-east Sardinia: Preliminary data. Jo De Waele, Darryl Granger. 838
- Preliminary development of a quantitative karst classification system, PHORMS. Daniel H. Doctor, Benjamin F. Schwartz, Marcus O. Gary. 843
- Tectonic influences on speleogenesis in the Guadalupe Mountains, New Mexico and Texas, USA. Harvey R. DuChene, Kimberly I. Cunningham. 849
- Speleogenesis of the New England marble caves. Trevor Faulkner. 855
- The general model of cave development in the metalimestones of the Caledonide Terranes. Trevor Faulkner. 863
- Flow distribution at early stage of karstification and 3D geometry of cave systems. M. Filipponi, P.-Y. Jeannin. 871
- Morphology of Tjoarvekräjge – the longest cave of Scandinavia. Torstein Finnesand, Rane Curl. 878
- Correlation between passage levels in the Bellamar Cave System and marine terraces surrounding the Bay of Matanzas, Cuba. Esteban Grau González—Quevedo, Ivonne Vázquez de la Torre, Humberto Fernández Ramos. 884
- How karst works in Grand Canyon, Arizona, USA. Carol A. Hill, Victor J. Polyak. 885
- The possible speleogene-hypogene origin of the Warda Iron Ore Mine deposit (Jordan). Stephan Kempe, Ahmad Al-Malabeh, Horst-Volker Henschel. 891
- The deepest cave in the world in the Arabika Massif (western Caucasus) and its hydrogeological and paleogeographic significance. A.B. Klimchouk, G.V. Samokhin, Y.M. Kasian. 898
- Hypogenic speleogenesis in the Piedmont Crimea Range. A.B. Klimchouk, E.I. Tymokhina, G.N. Amelichev. 906
- Bathypheatic speleogenesis of some large karst springs in Croatia. Mladen Kuhta, Andrej Stroj, Željka Brkić, Alan Kovačić. 907
- First elements of the karstic evolution of a continental chalk catchment area of the Paris Basin, upper Avre River (Normandy, France). Laurent Magne, Joël Rodet. 908
- Speleogenesis of the hypogenic caves in central Italy. Marco Menichetti. 909
- Unique dissolutional morphologies in caves: A result of convective flow regimes. John E. Mylroie, Joan R. Mylroie. 916
- Karst Development in the Castile Formation of Eddy County, NM and Culberson County, TX: A study of multiple models for regional speleogenesis. Raymond Nance, Kevin Stafford. 923
- The speleogenesis of Kanaan Cave, Lebanon: Geomorphological interpretation and paleoenvironment records of Antelias Region. Carole K Nehme. 930
- The geomorphological mapping of Kanaan Cave, Lebanon: A new approach in the speleogenesis of a cave. Carole K. Nehme. 936
- Early Carboniferous unlithified cave sediments: Their implications. R.A.L. Osborne. 939
- Geologic history of the Black Hills Caves, South Dakota, USA. Arthur N. Palmer, Margaret V. Palmer, Victor Polyak, Yemane Asmerom. 946
- Geologic setting, structure, tectonic history and paleokarst as factors in speleogenesis in the Guadalupe Mountains, New Mexico and Texas, USA. J. Michael Queen. 952
- Pre-drainage development of the caves of the Guadalupe Mountains, New Mexico and Texas, USA. J. Michael Queen. 958

- Post-drainage evolution of the caves of the Guadalupe Mountains, southeastern New Mexico and west Texas, USA. J. Michael Queen. 964
- Regional geologic evolutionary effects on speleogenesis at Villa Luz Park, Tabasco, Mexico. Laura Rosales-LaGarde, Penelope J. Boston, Andrew Campbell, Dana Ulmer-Scholle, Peter Scholle. 971
- Geological evolution of the Cobleskill Plateau, New York State, USA. Paul A. Rubin. 972
- Cave sediments as records of landscape evolution in the eastern Alps. Diana Sahy, Philipp Häuselmann, Bernhard Grasemann, Peter Kubic, Bettina Schenk, Kurt Stüwe, Thomas Wagner, Markus Fiebig. 979
- Speleogenesis as a component of corrosion of the Earth surface, with an example from the Big Levels of the Appalachian Plateau, USA. Ira D. Sasowsky. 980
- Hypogene processes in the Balcones Fault Zone, Edwards Aquifer, south-central Texas, USA. Geary M. Schindel, Steven B. Johnson, E. Calvin Alexander Jr. 983
- Geomorphic and hydrogeologic evolution of karst in the Burnsville Cove, Virginia, USA: New evidence and perspectives. Benjamin F. Schwartz, Daniel H. Doctor. 984
- Ascending water of the Delaware Basin, southeastern New Mexico, and far west Texas. Kevin W. Stafford, Raymond Nance. 991
- Typology, genesis, and evolution of tunnel-caves in southwestern China. Nathalie Vanara, Richard Maire. 998
- Messinian karst in Monferrato gypsum areas (north Italy). Bartolomeo Vigna, Adriano Fiorucce, Jo De Waele, Cinzia Banzato. 1003
- Bullita Cave, Gregory Karst, N.T. Australia: A maze cave in Proterozoic dolomite. Susan White, Nicholas White. 1010
- Symposium 12. Unearthing Secrets of the Past from Speleothem Studies** 1015
- Evolution of karst system from U-series dating and fabric analysis: A case-study from Romania. Silviu Constantin. 1017
- Temporal variability of cave-air CO₂ in central Texas. Brian D. Cowan, Michael C. Osborne, Jay L. Banner. 1018
- Age ~ depth model construction using full information from samples age and depth distributions basing on ²³⁰Th/U, radiocarbon and ²¹⁰Pb dating results. Helena Hercman. 1024
- Factors promoting preservation bias in speleothem growth. Eric W. James, Jay L. Banner. 1025
- Glacial cave ice as the cause of wide-spread destruction of interglacial and interstadial speleothem generations in central Europe. Stephan Kempe, Ingo Bauer, Heiko Dirks. 1026
- Dating of speleothems from deep parts of the world's deepest cave – Krubera (Arabika Massif, western Caucasus). A.B. Klimchouk, G.V. Samokhin, H. Cheng, R.L. Edwards. 1032
- Uranium mapping in speleothems: Occurrence of diagenesis, detrital contamination and geochemical consequences. Richard Maire, Guillaume Deves, Anne-Sophie Perroux, Benjamin Lans, Thomas Bacquart, Cyril Plaisir, Richard Ortega. 1033
- Geochemical study of a Holocene stalagmite from the Jeita Cave (Lebanon): Implications for paleoclimate reconstruction in the Levant Region. Fadi H. Nader, Hai J. Cheng, Lawrence R. Edwards, Rudy Swennen, Sophie Verheyden. 1039
- Sea level high stand at 81 ka: Evidences from coastal caves of Mallorca. Bogdan P. Onac, Jeffrey A. Dorale, Joan A Fornós, Angel Ginés, Paola Tuccimei, David W. Peate. 1045
- Heinrich event 4 in a Puerto Rico stalagmite. Bogdan P. Onac, Victor Polyak, Limaris Soto, Thomas E. Miller, Ana-Voica Bojar, Yemane Asmerom. 1046
- Reconstructing paleo-rainfall in the western tropical pacific: Developing speleothem proxies. Judson W. Partin, Jay L. Banner, John W. Jenson, Fred W. Taylor, Terrence M. Quinn, Daniel Sinclair, M. Bayani Cardenas. 1047
- Capability of isotopic profiles from cave speleothems: Numeric correlation. Jacek Pawlak, Helena Hercman. 1050
- Comparative isotopic study of different types of ice in Scărișoara Ice Cave, Romania. Aurel Perșoiu, Bogdan Onac. 1056
- A high-resolution record of atmospheric-oceanic teleconnections during the late Holocene from a Florida speleothem. Jason S. Polk, Philip E. Van Beynen. 1057
- Overcoming initial ²³⁰Th problems in uranium-series dating without using ²³⁴U/²³²Th – ²³⁰Th/²³²Th isochrons. Victor Polyak, Yemane Asmerom. 1060
- Combined new paleoclimatologic and chronologic evidence from Petralona Cave, Greece. Nickos Poulianos, Athanasios Koutavas, Xianfeng Wang, Larry Edwards, Aris Poulianos. 1065
- Application of U-series dating method to fossil bones – new perspectives. Grzegorz Sujka, Helena Hercman. 1068
- Stable isotope variations during marine isotope stage 3 recorded in a stalagmite from V11 Cave, NW Romania. Tudor Tămaș, Bogdan P. Onac. 1069

- New Zealand cave records show the Southern Hemisphere to be paleoclimatically different: LGM at stage 4, no Younger Dryas, and a Polynesian Warm Period. Paul W. Williams, H. Neil, Jian-Xin Zhao. 1070
- Investigating the controls on non-linear relationships between drip rate and drip-water composition in central Texas karst, USA. Corinne Wong, Jay L. Banner. 1071
- Symposium 13. 2009 International Cave and Karst Management Symposium: Worldwide Horizons in Cave and Karst Management** 1079
- Development and spatial distribution of karst systems on the Tongass National Forest, southeast Alaska. James F. Baichtal, Johanna L. Kovarik. 1081
- Karst and caves of the Hoholotna River region, southwestern Alaska. James F. Baichtal, Marti L. Miller, Susan M. Karl, Dwight C. Bradley, Robert B. Blodgett. 1082
- Geohydrology of a Sonoran Desert mountain-front karst aquifer. Robert Casavant, Eric Cook, Heidi Lauchstedt. 1083
- Rusticles of Kartchner Caverns State Park – lessons in speleogenesis, engineering, and show cave management. Robert Casavant, Heidi Lauchstedt, Mary Kumiega. 1084
- The ISCA management guidelines for show caves. Arrigo A. Cigna. 1085
- The International Commission on sustainable development in show caves. Arrigo A. Cigna, David Summers. 1089
- Preliminary developments for karst protection in Quintana Roo, Mexico. James G. Coke IV. 1092
- Cavern of Santa Catalina's management plan. Esteban Grau González-Quevedo, Ivonne Vázquez de la Torre, Ercilio Vento Canosa. 1096
- Mitigating oil and gas drilling and production operations in karst lands: Ten years of problem solving and progress. James R. Goodbar. 1097
- The European Cave Protection Commission (ECPC) – a new movement for cave protection in Europe. C. Grebe, V. Lascu, I. Meleg, A.S. Reboleira. 1102
- European speleology in European politics. C. Grebe, V. Lascu, I. Meleg, A.S. Reboleira. 1103
- Leye-Fengshan, a new applicant of global geopark Inguangxi, China. Yuanhai Zhang, Chen Weihai, Huang Baojian. 1104
- What can you do with a worn-out show cave? Dunbar Cave, Tennessee as a success story. William R. Halliday. 1108
- Environmental problems of *Telaga* (Doline Pond) in Gununsewu Karst, Java Indonesia. Eko Haryono, Tjahyo Nugroho Adji, Margareta Widyastuti. 1112
- Utility of cave cricket monitoring method developed by Cumberland Piedmont network ecologists for Mammoth Cave National Park. Kurt Lewis Helf, Robert Woodman. 1117
- A comparison of two cave cricket (*Hadenocetus subterraneus*) monitoring protocols. Kurt Helf, Kathleen H. Lavoie, Robert Woodman, Thomas L. Poulson. 1121
- Environmental deteriorations, policies, and management of Indonesian karst. Masneliyarti Hilman, Heddy S. Mukna, Edy S Nugroho, Eko Haryono. 1122
- An overview survey of cave and karst resources managed by Parks Canada. Greg Horne. 1123
- High CO₂ concentrations and cave ventilation test in the Milandre Cave, Jura Mountains, Switzerland. P.-Y. Jeannin, E. Weber, R. Wenger, P.-X. Meury. 1129
- Cave and karst conservation and management in Switzerland. Pierre-Yves Jeannin, Oliver Hitz. 1134
- Karst features discovered during motorway construction. Martin Knez, Tadej Slabe. 1139
- Shilin – lithological characteristics, form and rock relief of the Lunan Stone Forests (South China karst). Martin Knez, Tadej Slabe. 1145
- Cave conservation online. Hilary Lambert, Val Hildreth-Werker. 1150
- Cave protection acts: Are they effective? Thomas Lera, . 1154
- Ecotourism management plan for “El Sauce” Cavern, Piedras Grandes, Córdoba Argentina. E. Lipps, T. Remia, P. Blanco, E. Gonzalez, M.I. Albe. 1162
- Classifying cave environments based on the energy flow levels (Case study of the Cave of Santana, Sao Paulo State, Brazil). Heros Augusto Santos Lobo, José Alexandre de Jesus Perinotto, Paulo César Boggiani, Ivo Karmann, Silmara Zago, Fábio Tomaz Leonardo, Stanislas Pourou, Oduvaldo Viana Júnior. 1166
- Trends for tourist carrying capacity in Brazilian caves. Heros Augusto Santos Lobo, Paulo César Boggiani, José Alexandre de Jesus Perinotto. 1167

- Complex speleological exploration of Kapova Cave (Shulgantash) as basis for protection of its unique paleolithic painting. Y.S. Lyahnizkiy, A.A. Yushko, O.A. Minnikov, O.J. Chervyazova. 1168
- Karst and geodiversity initiatives in NSW, Australia. Stephen F. Meehan. 1173
- Baatara Pothole site: Overview and development perspectives. Marc Metni, Johnny Tawk. 1179
- Kassarat Cave – Antelias: Catchment works hazard assessment. Marc Metni, Sami Karkabi, Issam Boujawdeh, Rena Karanouh, Maia Sarrouf. 1185
- Robber Baron: Restoring an urban cave preserve. Joseph N. Mitchell, Linda K. Palit. 1191
- Monitoring of microbial populations in Kartchner Caverns State Park – a cost-effective cave management and outreach strategy. Julie W. Neilson, Luisa A. Ikner, Robert R. Casavant, Rickard S. Toomey, Ginger Nolan, Raina M. Maier, Eric Cook. 1197
- Cave and karst management in Great Smoky Mountains National Park. Daniel C. Nolfi. 1198
- The guides of Venezuela’s Guacharo Cave: A historical and ethnographic study of local’s contribution to its promotion, exploration, and conservation. María Alejandra, Pérez, Govinda Galindo. 1202
- Bold new resource management program at Timpanogos Cave National Monument, a National Park Service centennial strategy. Camille Pulham, Andy Armstrong. 1208
- Urbanization-induced trends in spring discharge from a karstic aquifer – Barton Springs, Austin, Texas, USA. John M. Sharp Jr, Leslie E. Llado, Trevor J. Budge. 1211
- Sedimentology of particulate accumulation and its remediation, Skull Ice Cave, Lava Beds National Monument, California, U.S.A. John C. Tinsley III, Kenneth Miller, Robert A. Johnson. 1217
- Relighting Mammoth Cave’s New Entrance: Improving visitor experience, reducing exotic plant growth, and easing maintenance. Rickard S. Toomey, Richard A. Olson, Steve Kovar, Mike Adams, Robert H. Ward. 1223
- Mammoth Cave International Center for Science and Learning. Rickard S. Toomey, III, Shannon R. Trimboli, Robert H. Ward, Mike Adams, Blaine Ferrell. 1229
- Save the Hole World campaign – cave protection in the European Parliament. Baerbel Vogel, Christiane Grebe. 1233
- Prototype site for integrated speleological research: La Cueva de las Barrancas. Val Hildreth-Werker, Jim C. Werker, Penelope J. Boston. 1238
- Speleothem repair: Rehang large broken stalactites. Jim C. Werker, Val Hildreth-Werker. 1246
- Hydro-electric power proposal, Iralalero-Paitchau Karst, Timor-Leste. Susan White, Nicholas White, Greg Middleton. 1253
- Fungus and cave management. Nicholas White. 1260
- A comparative cave climate study in southeastern Arizona – partnerships in cave management and climate change modeling. Steve Willsey, Robert Casavant, Rick Toomey, Jerry Trout, Ginger Nolan. 1266
- Cave conservancy management. John M. Wilson, Diane Cousineau. 1267

Contributed Papers in the Biological Sciences 1275

- Hot caves record in Mexico. Saúl Aguilar, Ada Ruiz, Juan Morales-Malacara. 1277
- Epikarst microbial assemblages in Padurea Craiului Mountains (NW Romania). Traian Brad, Adriana Bica, Ioana Meleg, Oana Moldovan. 1279
- Guanophile ecosystem of an urban cave polluted with raw sewage. Greg Brick. 1280
- Description of the biota on a representative sample of the systems of karst (Guanentina Region and Vélez Province) Santander – Colombia. Diego Casallas-Pabón, Mario Andrés Murcia López, Yaneth Muñoz-Saba. 1281
- Preliminary report on the cave Diplura of Colorado (Hexapoda: Diplura: Campodeidae). Lynn M. Ferguson. 1283
- Development and application of a database for the subterranean amphipod crustacean genera *Stygobromus* and *Bactrurus*. John R. Holsinger, Justin Shafer, Grace Schulte. 1286
- The cave fauna of Texas. Jean K. Krejca, James R. Reddell, George Veni. 1290
- White-nose syndrome in hibernating bats: Are these affected bats the next “canary in the mine”? Thomas H. Kunz, David S. Blehert, Paul M. Cryan, Jeremy T.H. Coleman, Alan Hicks, Merlin D. Tuttle. 1291
- Effects of incubation conditions on quantification of chemoheterotrophic bacteria from caves. Kathleen H. Lavoie, Diana E. Northup, Jessica R. Snider, Nwamaka A. Nwagbologu. 1292
- Invertebrate colonization and deposition rates of guano in a man-made bat cave, the Chiroptorium, Texas, USA. Kathleen H. Lavoie, Diana E. Northup. 1297
- Effects of missing legs on distribution and jumping behavior in the cave cricket, *Hadenoeus subterraneus*. Kathleen H.

- Lavoie, Mohammed Chandoo, Suganthi Thirunavukarasu, Utsave Pandey, Elizabeth Lavoie, Kurt Helf. 1302
 Species limits, phylogenetics, and conservation of *Neoleptoneta* spiders in Texas caves. Joel Ledford, Pierre Paquin, Charles Griswold. 1307
- Untangling the webs in California's caves: The biogeography and systematics of the cave spider genus *Usofila*. Joel Ledford, Charles Griswold, Rosemary Gillespie. 1308
- Zoogeography and evolution of the subterranean asellid isopods of North America. Julian J. Lewis. 1309
- Structure characterization of the arthropod fauna community in cave of "The Rascadero," Santander, Columbia. Mario Andrés Murcia López, Diego Casallas-Pabón, Yaneth Muñoz-Saba. 1315
- Small-scale spatial distribution of aquatic fauna in caves from northwestern Romania (eastern Europe). Ioana Nicoleta Meleg, Oana Teodora Moldovan, Sanda Iepure, Traian Brad. 1316
- Ecological studies in interstitial habitats of Romanian Carpathians (eastern Europe). Oana Teodora Moldovan. 1317
- Energy flow in the caves with emphasis in its arthropofauna with special reference to (Santander) Colombian caves. Yaneth Muñoz-Saba, Ligia Rosario Benavides-Silva, Manuel Antonio Hoyos-Rodríguez, Mario Andrés Murcia López, Diego Casallas-Pabón. 1318
- Colombian bats from the caves. Yaneth Muñoz-Saba, Manuel Antonio Hoyos-Rodríguez, Diego Casallas-Pabón. 1320
- Biospeleological provinces in Columbia. Yaneth Muñoz-Saba, Luis Guillermo Baptiste, Danilo Salas. 1321
- Methods for counting cave crickets. G. Robert Myers III. 1322
- Review and assessment of known cavernicoles and rare epigean biology of karst and caves, Great Smoky Mountains National Park. Daniel C. Nolfi. 1323
- From cryophily to troglomorphy: Morphological and molecular evidence for the evolution towards troglomorphy in three different lineages of the genus *Cicurina* (Araneae: *Dictynidae*) Pierre Paquin, Nadine Dupérré. 1329
- Cave *Myotis* (*Myotis velifer incautus*) roost monitoring and protection on Fort Hood Army Installation, Texas, USA. Charles E. Pekins. 1330
- New studies of *Speoplatyrhinus poulsoni* (Pisces: Amblyopsidae). Thomas L. Poulson. 1337
- Field metrics for cave stream bio-integrity. Poulson, Thomas L. 1343
- Visual observations of the macroscopic life in Puerto Rican caves. Ronald T. Richards 1349
- Vertebrate species in underground features of Arizona. Thomas R. Strong. 1356
- Cave communities in Missouri – A comparison of nutrient rich and nutrient poor settings. Michael Sutton. 1361
- Spatial and temporal distribution of terrestrial macroinvertebrates in Lehman Caves, a tourist cave in Great Basin National Park, Nevada, USA. Steven J. Taylor, Jean K. Krejca, Michael E. Slay. 1367

Contributed Papers in Conservation and Management 1369

- Documentation of caves and karst in Western Australia. Ross Anderson. 1371
- Preliminary studies on soil erosion intensity grading in southwest karst area, China. Jianhua Cao, Jiang Zhongcheng, Yang Desheng, Pei Jianguo, Yang Hui, Luo Weiqun. 1372
- Research priorities for underground ecosystems in Colombia. Brigitte Luis Guillermo Baptiste, Yaneth Muñoz-Saba, Danilo Salas, Manuel Antonio Hoyos-Rodríguez. 1380
- A cave survey for research and tourist cave management. Julia M. James, David J. Martin, Gregory M. Tunnock, Alan T. Warild. 1381
- Cave and karst resource inventory and monitoring on the Tongass National Forest, southeast Alaska, USA. Johanna L. Kovarik, 1388
- Karst cave system types and their protection in China. Yaoru Lu, Keqiang He. 1375

Contributed Papers in the Earth Sciences 1399

- Karst cave features of Mongolia. E. Avirmed. 1401
- Thermal sedimentation in caves: A note. Giovanni Badino. 1402
- The sound of natural caves. Giovanni Badino. Roberto Chignola. 1403
- The Cueva de los Cristales micrometeorology. Giovanni Badino. 1407
- Decline of cave ice – a case study from the Austrian Alps (Europe) based on 416 years of observation. Michael Behm, Veronika Dittes, Robert Greilinger, Helga Hartmann, Lukas Plan, Dieter Sulzbacher. 1413

- Effects of surface morphologies on flow behavior in karst conduits. Aaron Bird, Gregory S. Springer, Rachel F. Bosch, Rane L. Curl. 1417
- Preliminary water quality and boundary redefinition of the Scott Hollow Drainage Basin, Appalachian Plateau, USA. Melisa R. Bishop, Ira D. Sasowsky, William K. Jones. 1422
- Flow characterization from epikarst and shallow bedrock springs across a range of hydrologic conditions, Savoy Experimental Watershed, Ozark Region, U.S. Van Brahana, Ralph Davis, Phillip D. Hays, Kenneth F. Steele. 1428
- Fluorescence characterization of karst aquifers. Terri Brown, Sid Jones, Larry McKay. 1429
- Atrazine contamination and suspended sediment transport within Logsdon River, Mammoth Cave, Kentucky, USA. Julie E. Schenck Brown, Stephen T. Kenworthy. 1435
- Tiankengs in the karst of China. Weihai Chen, Zhu Xuwen. 1440
- Delineating spring flow systems in the Texas Hill Country, USA. Ali H. Chowdhury, Chad Norris. 1446
- Karst microclimate monitoring in the northern Alps, Austria: Initial results. Aaron Curtis. 1452
- Geomorphological evolution and digital mapping of the Ksiromero Region, western Greece. Miljana Golubovic Deligianni, Kosmas Pavlopoulos, George Veni, Issaak Parcharidis. 1458
- Morphological relationships between erratic boulders and associated bedrock limestone fins or “rock comets”, Madre de Dios Archipelago, Chile. Joel Despain, Richard Maire, Stephan Jalliet. 1463
- Extreme increase of CO₂ in Belgian Caves. Camille Ek, Jean Godissart. 1467
- Overview of the non-karst caves in Hungary. István Eszterhás, George Szentes. 1474
- From the Plains of Abraham to Dodo Canyon: Remarkable dolomite karst in permafrost in the MacKenzie Mountains, Northwest Territories, Canada. Derek Ford. 1481
- New Research in the South Nahanni Karst, MacKenzie Mountains, Northwest Territories, Canada. Derek Ford, Stephen Worthington. 1482
- DNA analysis of fecal bacteria to augment an epikarst dye trace study at Crumps Cave, Kentucky, USA. Rick Fowler, Brian Ham, Chris Groves, Carl Bolster. 1483
- Dating a biblical lady: An unroofed salt cave gives birth to Lot’s wife. Amos Frumkin. 1490
- Geologic and hydrogeologic conditions in speleogenesis of the longest and deepest caves in karst of Croatia. Mladen Garašić, Davor Garašić. 1495
- Problems with caverns which were found on the route of the highways in Croatian karst region (Dinaric Karst). Mladen Garašić. 1500
- Dye tracing oil and gas drilling fluid migration through karst terrain: A pilot study to determine potential impacts to critical groundwater supplies in southeast New Mexico, USA. James R. Goodbar. 1507
- Cave development influenced by hydrocarbon oxidation: An example from the Polish Tatra Mts. Michał Gradziński, Marek Duliński, Helena Hercman, Michał Żywiecki, Janusz Baryła. 1511
- Study of temperature and airflow in the Schellenberger Ice Cave (Berchtesgadener Limestone Alps, Germany). C. Grebe, J. Ringeis, A. Pflitsch. 1512
- Differentiating karstic and pseudokarstic caves and closed depressions in the American Southwest, USA. William R. Halliday. 1513
- Using conservative and biological tracers to better understand the transport of agricultural contaminants from soil water through the epikarstic zone. Brian Ham, Rick Fowler, Chris Groves, Carl Bolster. 1519
- The karst hydrogeochemical features in the catchment of Baiyandong underground river, Baojing, Hunan, China. Shiyi He, Pei Jianguo, Xie Yunqiu. 1524
- Recent observations in a remarkably dynamic, sulfide-rich, hypogenic cave in southern Mexico. Louise D. Hose. 1525
- The big cave and chambers in Poyue Underground River drainage in south China and its controlling factors. Huang Baojian, Zhang Yuanhai, Chen Weihai. 1531
- Twenty years of monitoring, tests and experiments in the Milandre Cave, Jura Mountains, Switzerland: Inputs for karst hydrogeology. Pierre-Yves Jeannin. 1536
- Impact assessment of a tunnel on two karst springs, Flims, Switzerland. Pierre-Yves Jeannin, Philipp Häuselmann, Eric Weber, Andres Wildberger. 1537
- Tracing groundwater flowpaths in the Edwards Aquifer recharge zone, Panther Springs Creek Basin, northern Bexar County, Texas, USA. Steve Johnson, Geary Schindel, George Veni. 1538
- Urban karst drainage problems in the Ensor Sink – Tires-to-Spare System, Cookeville, Tennessee, USA. Sidney W. Jones,

- Richard C. Finch. 1539
- The importance of karst aquifers to public and domestic water supplies in the United States. William K. Jones, 1544
- Some evidence of hydrothermal speleogenesis in the Akka Limestone, northern Kitakami Massif, Japan. Naruhiko Kashima, Hidesato Kuwahara. 1548
- Evolution of the Biś Nik Cave environment (Krakow-Wielun Upland, southern Poland) Katarzyna Kasprowska, Viacheslav Andreychouk. 1551
- Morphogenetic classification of talus caves based on geometry of clasts and sequential development. Ernst H. Kastning, 1555
- The sinkholes of Layla Lakes: Saudi Arabia and their singular sub-lacustrine gypsum tufa. Stephan Kempe, Heiko Dirks, Ingo Bauer, Randolph Rausch. 1556
- Geomicrobiology and hydrology of pool precipitates in the Guadalupe Mountains, New Mexico, USA. Ara Kooser, Laura Crossey, Diana Northup, Mike Spilde, Leslie Melim. 1562
- Conduit flow process (CFP) for MODFLOW-2005. Eve L. Kuniatsky, W. Barclay Shoemaker. 1568
- Anthropogenic sinkholes in the Delaware Basin region of west Texas and southeastern New Mexico, USA. Lewis Land. 1575
- Carbonate dissolution in cold water: *In situ* experiments and the consequences for subglacial karstification. Lauritzen, Stein-Erik. 1581
- Fracture control of caves in marble: Earthquake mediated? Examples from Scandinavia. Stein-Erik Lauritzen. 1582
- Natural history of Clay Cave, Napa County, California. Matt Leissring, Rolf A. Aalbu, Bruce W. Rogers. 1583
- Unusual talus-fissure caves in Tuolumne County, California. Matthew Leissring, William Frantz, Bruce W. Rogers. 1584
- Contaminant transport in two central Missouri karst recharge areas. R.N. Lerch. 1585
- Recording a flood event inside the Water Sinks Cave. Philip C. Lucas, 1593
- Stratigraphic and structural control of cave development in Sinkhole Flat, Eddy County, New Mexico, USA. Lucas C. Middleton, Raymond G. Nance, Kevin Stafford. 1597
- Collapse dolines of the Divača Karst, Kras Plateau, Slovenia. Andrej Mihevc. 1600
- Bellholes and bellbasins: Biogenic (bat) cave features of Puerto Rico and the neotropics. Thomas E. Miller, Maria Figueroa-Mulet. 1605
- Morphology of solution-dominated vs. clastic-dominated cave passages in the Caves Branch Karst, Belize. Thomas E. Miller. 1612
- Airflow and CO₂ in Robber Baron Cave. Joseph N. Mitchell, Evelyn J. Mitchell. 1613
- Monitoring dripwater chemistry in El Refugio Cave (southern Spain) as a contribution to understanding infiltration and speleogenetic processes in karst aquifers. M. Mudarra, B. Andreo, I.J. Fairchild, J.A. Barbera, I. Vadillo. 1620
- A major unmapped fault in Ganter Cave, and possible geomorphological effects on Turnhole Bend of Green River, Mammoth Cave National Park. Rickard A. Olson, Rickard S. Toomey. 1626
- Jewel Cave and Wind Cave vs. one Black Hills Cave System. Andreas Pflitsch, Julia Ringeis. 1632
- Jewel Cave and Wind Cave – differences and common features of the two large cave systems in the Black Hills of South Dakota. Andreas Pflitsch, Julia Ringeis. 1637
- Geology and tectonics of Polovragi Cave – Romania. Gheorghe Ponta, Gheorghe Aldica. 1638
- Influence of meteorology on speleothem deposition: Example from Križna Jama, Slovenia. Mitja Prelovšek. 1643
- The Lost City: Hot springs, mixing and a possible model for folia development. J. Michael Queen. 1650
- Morphodynamic incidences of the trepanning of the endokarst by solution pipes. Examples of chalk caves in western Europe (France and Belgium). Joël Rodet, Luc Willems, Joël Brown, Sylvie Ogier-Halim, Marie Bourdin, Jean-Pierre Viard. 1657
- Development and function of a perched aquifer in the covering layers of the chalk limestone in the Paris Basin (France). Joël Rodet, Joël Brown, Jean-Paul Dupont. 1662
- Cyrenaica Karst project (north-eastern Lybia). Rosario Ruggieri, Mohamed Abdelmalik. 1667
- Mormon Lake – an Arizona USA polje. Graham M. Schindel, Geary M. Schindel. 1672
- Caves formed by cambering in the southern Cotswold Hills, England. Charles Self. 1673
- Karst hydrology in Utah – an overview. Lawrence E. Spangler. 1678
- Groundwater/surface-water relations and water quality within the Mammoth Spring watershed, Markagunt Plateau, southwestern Utah, USA. Lawrence E. Spangler. 1685
- Karst and groundwater in northeastern Coahuila: An Edwards Aquifer mirror. Peter Sprouse. 1690
- Microclimatic changes during the total solar eclipse on August 11, 1999 and their impact on bat colony activity. Alexey Stoev, Penka Stoeva, Trifon Daaliev. 1693
- Influence of the solar and geomagnetic activity on cave climate. Penka Stoeva, Alexey Stoev, Trifon Daaliev. 1694

- International caving studying thermographic anomalies of cave or lava tube entrances for NASA, analog Moon and Mars. Jim Thompson. 1695
- Hidden Spring – a long-known resurgence with a newly identified carbonate aquifer chemistry in Sequoia and Kings Canyon National Parks, California, U.S.A. John C. Tinsley III. 1666
- Estimating karst conduit length using conductivity and discharge measurements in Lilburn Cave, Kings Canyon National Park, California. Benjamin Tobin, Daniel H. Doctor. 1702
- Classification of karst deposits from the Franconian Alb (southern Germany). Martin Trappe. 1707
- Identifying hypogenic features in Greek caves. M. Vaxevanopoulos. 1713
- Preliminary hydrogeologic survey of Petralona Cave, Chalkidiki, Greece. George Veni, Nickos A. Poulianos, Miljana Golubovic Deligianni, Aris N. Poulianos. 1707
- Cave climate studies and the potential extent of the Jewel Cave System. Michael E. Wiles, Rene Ohms, Andreas Pflitsch. 1723
- The cadmium forms in the soil of karst region and their effects on water quality. Yunqiu Xie, Zhang Min, Deng Yan. 1728
- Study of soil factors and karst processes of different land uses of vertical zoned climatic area, Jinfo Mountain, Chongqing, China. Cheng Zhang, Yuan Daoxian. 1731
- Age of cave fills in Slovenia. Nadja Zupan Hajna, Andrej Mihevc, Petr Pruner, Pavel Bosák. 1735

Contributed Papers on Exploration 1737

- Exploration in Dry Cave 2005–2009, Guadalupe Mountains, New Mexico. Stan Allison, Aaron Stockton. 1739
- Two hundred kilometers in Lechuguilla Cave. Andy Armstrong, John T.M. Lyles. 1744
- Resurvey of Sitting Bull Crystal Caverns, South Dakota, USA. Andy Armstrong. 1750
- The Grand Coyer Karst, exploration at the Coulomp Spring (Alpes-de-Haute-Provence, France). Philippe Audra, Ludovic Mocochain, Jean-Yves Bigot, Jean-Claude D'Antoni-Nobecourt. 1755
- The Kronio Project: A first note. Giovanni Badino, Antonio de Vivo, Roberto Prelli, Francesco Sauro, Giuseppe Savino, Spartaco Savio, Roberta Tedeschi. 1760
- The Naica Caves survey. Giovanni Badino, Antonieta Ferreira, Paolo Forti, Giuseppe Giovine, Italo Giulivo, Gonzalo Infante, Francesco Lo Mastro, Laura Sanna, Roberta Tedeschi. 1764
- Exploration in Mammoth Cave. James Borden, Bob Osburn. 1770
- The karst of remote Houaphan Province in northern Laos. Jos Burgers, Joerg Dreybrodt, Francois Brouquisse. 1771
- The Teng Long Dong System and the caves and karst features of Lichuan County, Hubei Province, southwest China. Gerard Campion. 1772
- Mexpe: Sistema Tepepa and area. Christian Chenier. 1778
- Recent explorations in the Whippistle Cave System, Edmonson County, Kentucky, USA. Joel Despain, Pat Kambesis, John All, Don Coons. 1784
- Geomorphology of the Boquerones Cave System, Sancti Spiritus, Cuba. Joel Despain, Pat Kambesis, Javier Mugica Jeronimo, Cyndie Walck. 1785
- Recent explorations in the St. Paul Karst (Palawan, Philippines). Antonio De Vivo, Leonardo Piccini, Marco Mecchia. 1786
- Tláloc 2008 exploración – Mexico-Italia, Hueytamalco, Puebla, Mexico. J. Domínguez-Navarro, S. Santana-Muñoz, M. Díaz-Ávila, E. Hernández-Vargas, C. Cruz-García, M. Garcés-Trenado, J. M. Mangas-Moreno Trujillo-López, J. Madrigal-Gómez, V. Cruz-García, G. Pérez-Montes, A. Rodríguez-López, R. Álvarez-D. Brugali Rangel, A. Buzio, F. Camillieri, A. Corna, F. Finali, R. Gaiti, A. Iemmolo, N. Manno, F. Merisio, G. Pannuzzo, S. S. Virgillito Piccitto, F. Vitale, G. Zaccaria. 1793
- Exploration, geology, and hydrology of Sugar Run Cave System, Virginia. Andrea Futrell, Mike Futrell. 1799
- Caves of Tongzi, Wulong County, Chongqing, China. Mike Futrell. 1800
- Sub-alpine karst in northern New Mexico. John Ganter, John T.M. Lyles. 1801
- Study of the localization of the pits in the Plateau of Jurd Afqa (Mount Lebanon) using a geographical information system (GIS). Pierre-Charles Gerard, Badr Jabbour-Gedeon. 1802
- The fissure caves of North Carolina's Mystery Mountain, Rumbling Bald. Cato Holler. 1807
- Successful management of long-term survey projects. Patricia Kambesis, Peter Sprouse, Joel Despain. 1812
- Bob Osburn, John Pollack, Aaron Addison, Dave Bunnell. Tham Khoun Xe of Khammouane Province, Lao People's Democratic Republic (PDR). Patricia Kambesis. 1813
- Exploration of Krubera Cave, the deepest cave in the world: Twenty eight years beneath the Ortobalagan Valley, Arabika,

- western Caucasus. Y.M. Kasian, A.B. Klimchouk, K.S. Markovskoy, G.V. Samokhin. 1817
- 2008 Tongass Cave Project expeditions in south central and southeast Alaska. Johanna Kovarik, Kevin Allred, Steve Lewis. 1818
- Ten years underground with the Maya in Belize, Central America. David Larson, Eleanor Burns Larson, Brian Pease. 1823
- Crystal caves in Hungary. Szabolcs Leél-Össy. 1827
- Soaking wet in Dry Cave: The history of exploration with a promise for the future. Philip C. Lucas, William M. Balfour. 1828
- Eight years of exploration in China by Hongmeigui Cave Exploration Society. Erin M. Lynch, Duncan Collis, Mike Futrell. 1833
- Sistema Sima de la Cornisa – Torca Magali (-1507 m) (Picos de Europa, Spain). Jan Masschelein, David de Roest, David Lagrou, Wim Janse, Vicent Coessens. 1840
- New discoveries in underwater cave systems in Riviera Maya, Mexico. Zdeněk Motyčka. 1841
- New discoveries in the Amaterska Cave – the longest cave system of the Czech Republic. Zdeněk Motyčka. 1845
- 2005 to 2008 speleological discoveries in caves of Khammouane, Laos. Claude Mouret, Jean-Francois Vacquie, Charles Ghommhid, Jean-Michel Ostermann, Jacques Rolin, Helmut Steiner and the Team. 1848
- The international speleological expedition to Iran (2008). Fadi H. Nader, Jean-Pierre Bartholeyens, Mladen Garasic, Reinhold Heinrich (Rene) Scherrer, Simon Brooks, Javad Nezamdoost, ISEI Team. 1854
- Exploration and mapping of Sunnybrook Blowing Cave, Wayne County, Kentucky, USA. Randy Paylor. 1859
- The Centre-Terre Expeditions to Patagonian karst islands: An historic overview. Jean-François Pernette, Bernard Tourte, Richard Maire. 1860
- Preliminary overview on the karst areas of Kalaw (Myanmar). Leonardo Piccini, Antonio de Vivo, Francesco Lo Mastro, Tim Stratford. 1866
- The lava caves of Khaybar, Saudi Arabia. John J. Pint. 1873
- New light on old Guadalupian caves: Grays Cave rediscovered and Hamblens Cave entrance lost. J.M. Queen, M.O. Rosacker, A. Stockton. 1879
- Detailed speleological topography Angel Cave (Lucena, Córdoba, Spain). Fernando Rodríguez-Rojas. 1892
- Priego Subterranean Exploration Group (GESP). 50 years of speleology in Priego de Cordoba (Cordoba – Spain). Fernando Rodríguez-Rojas. 1896
- Houet Tabet: New discovery approach. Ghada Salem, Joseph Tabet, Jack Safi, Lorine Mouawad, Samer Amhaz, Mazen Arzouni, Carole Nehme. 1902
- Five years of speleological investigation in the karst of Sierra Mixteca-Zapoteca, south of Tehuacán, Oaxaca, Mexico. Francesco Sauro, Leonardo Piccini, Marco Mecchia. 1904
- Piani Eterni: Twenty years of explorations in the deepest cave of Dolomite Mountains, Venetian Alps, Italy. Francesco Sauro, Marialuisa Perissinotto, Alberto Riva, Cristiano Zoppello. 1911
- Dalovica Pecina, Montenegro. Jan Sirotek, Zdeněk Motyčka. 1918
- Xilitla: Locus of Mexican caving. Peter Sprouse. 1922
- Webster Cave complex survey update. Benjamin Tobin, Andrea Croskrey, Benjamin Hutchin, Chris Anderson. 1924
- Proyecto Akemabis 2008. Gustavo Vela Turcott, Al Warild, Franco Attolini Smithers. 1927
- Caves of Costa Rica (Central America) and their geologic origin. Andrés Ulloa. 1930
- Use of speleological techniques in ancient mine exploration. M. Vaxevanopoulos. 1936
- Recent exploration at Jewel Cave. Michael E. Wiles. 1937
- Large caves in China. Yuanhai Zhang. 1938

Contributed Papers on the Human Side: Art, History, Medicine, Philosophy, and the Social Sciences 1945

- The presence of Floyd Collins in the Mammoth Cave (KY) area today. John M. Benton. 1947
- Statistical analysis of American cave accident data. Richard L. Breisch. 1949
- The myth of the American Cave Man. Greg Brick. 1955
- Speleophilately: Some odd cave stamps. Jacques Chaber. 1957
- American underground: “Experiences out of time” and chronobiology. Allel Chama. 1964
- 38 years of publication of the Speleological Abstracts. Patrick Deriaz, Reno Bernasconi. 1970
- African Americans and the use of caves as hidden spaces in the antebellum and Civil War South. Joseph C Douglas. 1974

- The Naica Caves and human physiology. Giuseppe Giovine, Giovanni Badino, Antonio de Vivo, Francesco Lomastro, Giuseppe Casagrande, Alicia Davila, German Gonzalez Hidalgo. 1980
- Evolution of speleology in Costa Rica. Carlos Goicoichea, Gustavo Quesada, Andres Ulloa. 1985
- Over 130 years of study and research of Schellenberger Ice Cave and the ice caves at Untersberg (Berchtesgadener Limestone Alps, Germany). C. Grebe, J. Ringeis, A. Pflitsch. 1986
- Josef Anton Nagel and his 1748 manuscript about his cave expedition to Carniola (Slovenia) and Moravia (Czech Republic). Stephan Kempe, Klaus Suckstorff. 1987
- Early cave visits by women and the travel accounts of Lady Elisabeth Craven to the Grotto of Antiparos (1786) and Johanna Schopenhauer to Peaks Cavern (1803). Stephan Kempe, Christhild Ketz-Kempe, Erika Kempe. 1993
- Visitor inscriptions in the old passage of Postojnska Jama (Adelsberger Grotte)/Slovenia. Stephan Kempe, Hans-Peter Hubrich. 2000
- A cave survey project for the Duke of Edinburgh's Silver Award. Stephen Kennedy, Craig M. Barnes, Julia M. James. 2006
- The oldest printed cave maps in the world. Massimo Mancini, Paolo Forti. 2011
- Cave conservation through the arts: Carlsbad Caverns National Park's art gallery. Lois Manno. 2012
- Ethics of speleological expeditions to foreign countries. Claude Mouret. 2016
- Human use of caves in Martinique and Guadeloupe Islands, West Indies. Claude Mouret. 2021
- The map of ancient underground aqueducts: A nationwide project by the Italian Speleological Society. Mario Parise, Roberto Bixio, Ezio Burri, Vittoria Caloi, Sossio Del Prete, Carla Galeazzi, Carlo Germani, Paolo Guglia, Marco Meneghini, Mariangela Sammarco 2027
- Venezuela's Chaima indigenous community and its relation to national speleological practice. María Alejandra Pérez. 2032
- A rescue pre-plan for Lechuguilla Cave, Carlsbad Caverns National Park, New Mexico. John Panches, Anmar Mirza, Stan Allison. 2033
- Arch Spring and cave. Jack H Speece. 2038
- National and international partnership building for speleology: The U.S. National Cave and Karst Research Institute. George Veni. 2044
- Spelean history revealed when naming features for a cave survey. Jenny L. Whitby, Kath A. Bellamy, Julia M. James. 2048
- The National Speleological Society Museum: History, progress, and future directions. Amber J. Yuellig, Craig Hindman. 2054
- Contributed Papers on Methods and Technologies for Science and Exploration 2055**
- Blunder detection in complex survey networks. Peter Bosted. 2057
- LASER scanning use in cave contexts: the cases of Castellana (Italy) and Naica (Mexico) Erminio Paolo Canevese, Roberta Tedeschi, Paolo Forti. 2061
- Digital modes for cave radios. Raymond (Ray) Cole Jr. 2068
- The use of ground penetrating radar in karst areas: methodology, feasibility and interpretation. Jose Antonio Crispim. 2072
- The international trainings of cave rescue organized by the french since 1997. Christian Dodeli. 2073
- Always ready cave photography. Bill Frantz. 2074
- Terrain modeling and GIS techniques for cave expeditions in China. Mike Futrell. 2078
- The importance of geography and GIS in underground rescue. Rodrigo Valentin Gomez-Bermudez. 2083
- Organization of international caving camps: the Humpleu example. Philipp Häuselmann. 2084
- The UISIC workgroup "Topography and Mapping" and its activities. Philipp Häuselmann. 2088
- Making a digital map of Wind Cave, Wind Cave National Park, South Dakota. Rodney D. Horrocks, Daniel C. Austin. 2091
- The Sierra Negra in a PDA: expedition-wide electronic cave surveying. Luc Le Blanc. 2095
- A method for detecting cave connections by induced air flow. Philip C. Lucas, Frank Marks Jr, Nevin W. Davis. 2100
- The history of caving packs. Scott McCrea. 2106
- The Swaygo gear rack trap. Scott McCrea. 2107
- Digital photography in support of the LIDAR project, Edwards County, Texas USA. Kevin McGowan, Xueming Xue, Allan B. Cobb. 2108
- Very long zip-line with speleology techniques: modelization and measurements. Laurent Morel and Frédéric Chambat. 2113
- Light-emitting diodes in the illumination of show caves. Ján Novomeský. 2119
- Author Index 2121**

PREFACE

Five Hundred papers were presented at the Fifteenth International Speleological Congress, Kerrville, Texas, USA on July, 19–26, 2009 by speleologists from all over the world. These volumes contain the written record for those papers. Authors who chose to do so were invited to prepare full papers of up to six pages. Authors who preferred a more limited text contributed abstracts of their papers for the Proceedings.

The papers fall into two categories: those that were incorporated into the 13 symposia – 300 papers – and those that were contributed to topical sessions – 200 papers. Written accounts appear for both oral presentations and papers that were presented as posters. The papers are arranged alphabetically by first author in the sequence Plenary lectures, Symposia papers, and Contributed papers.

Both abstracts and papers received comprehensive technical reviews by the Science Committee. The authors had the opportunity to revise their papers in response to reviewer's comments. It is hoped that the review process has improved the clarity of the papers so that information transfer is enhanced.

The papers in these Proceedings span the entire range of subjects that might be of interest in the study of caves. Science, of course. There are papers describing new

findings in archaeology, biology, microbiology, geology, hydrogeology, geophysics, meteorology, mineralogy, and paleoclimatology. Certainly of great interest is exploration. Speleologists who have been pushing the frontiers in all corners of the world and have been tackling caves of extreme difficulty report their latest discoveries. There are papers on new techniques for exploration, cartography, and research. There are a very large number of papers dealing with conservation and management of caves and karst regions. The human side of speleological interests has not been forgotten. There are papers concerning art, history, and the social sciences.

Because of the planetary (or perhaps interplanetary) scale of interest both in subjects and in contributors (we have papers on Mars but so far, no contributions by Martians) the International Congress of Speleology represents an up-to-date cross-section of the current knowledge of all matters pertaining to caves. Many of the papers have extensive bibliographies which will guide the reader deeper into the subject of interest.

We thank everyone of the hundred of authors for their contributions. We also thank the reviewers who were generous with their time and efforts to improve the quality of these Proceedings.

William B. White
Proceedings Editor

PLENARY LECTURES

AN UP TO DATE REPORT OF CAVE EXPLORATION AROUND THE WORLD

ANDY EAVIS

*President of the International Union of Speleology (UIS)
Tidesreach, Redcliff Road, Hessle, East Yorkshire, United Kingdom, HU13 0HA*

I am pleased to report that cave exploration around the world is still flourishing. We are arguably still in its Golden Age and long may it continue. We must remember that we are exceedingly lucky to be working in one of only two truly unexplored regions on the planet, the other being deep ocean.

As cave exploration has progressed, so has technology. This has opened up more difficult caves, both in terms of endurance—greater length and depth, including underwater—and also by means of digging sediment-filled passages or enlarging small connecting passages to get into bigger caves. This means that in many areas of the world where past glaciations have blocked entrances; there is still a considerable amount of cave passage to be discovered. In my own country, Great Britain, it is probable that less than 50% of caveable passage has so far been explored with new and often spectacular discoveries being made all the time. This is true of all the traditional developed caving areas, particularly Europe and North America.

More remote areas that have not previously been visited by speleologists are also being opened up. There are many completely untouched places that have been visited and many more to be looked at into the future. China is a prime example. Very little had been done prior to 1982 and now less than 30 years later, it has many of the largest, longest and deepest known caves in the world with undoubtedly a lot more to go at. Other countries of Asia, Africa, South America, etc. are still quite unknown as far as cave exploration is concerned. It is probable that less than 10% of all the world's caves with the potential for human exploration are so far known. Cave diving has yielded spectacular results with relatively new areas such as the Yucatan Peninsular in Mexico and Australia's Nullarbor Plain producing hundreds of kilometres of submerged passage. Again technology is moving fast and who knows, maybe mini-submarines will become common in underwater cave exploration. Parallel with cave discoveries in limestone has been exploration in non-limestone caves including volcanic rocks, quartzite, salt, gypsum and ice with, in some cases, underground voids being a combined result of more than one process.

This leads on to the continuing growth of cave science. While occasionally cave discoveries lead to archaeological finds adding to the knowledge of mankind's ancient past, their historical record goes back far beyond that. Our understanding of the hundreds of thousands, even millions, of years of historical information contained in the speleothems, sediments and the rock itself is continually progressing. There is no doubt that the understanding of cave science greatly assists the explorer on his quest for more passage.

1. Introduction

Dr. John Hemming the previous Director of the British Royal Geographical Society wrote in his book entitled *The Golden Age of Discovery*, "gallant cavers are exploring their underground frontier in all parts of the world, moving on from caves of Europe, Canada, and the United States to new systems in such countries as Mexico, Peru, Vietnam, and the Republics of the former Soviet Union in Central Asia. They are probably too busy penetrating unexplored caves and establishing new records to consider that we are also living in the golden age of Speleology." This view by a very eminent explorer sums up the wonderful situation we are in.

Unfortunately in preparing this presentation, it became obvious that it would not be possible to cover anything like everything that is currently going on around the world in speleological exploration. So this is an almost random selection of activities, hopefully picking out many of the more important ones, and should give an overview of who is doing what in many places.

At the end of this paper, there is a list of people who have contributed towards this compendium. I thank them most sincerely for their efforts. Use of the internet in conjunction with individual names should enable any reader to home in

on many of the activities mentioned.

For this report I have broken the world down into regions:

1. Europe; 2. The whole of Asia including Central East, West and South; 3. Australasia; 4. North and Central America; 5. South America; and, 6. Africa.

Since I am British, that is where I will start. I intend in many cases to cover what is going on in a country or region then what the speleologists from this region are doing in other parts of the world.

2. Europe

The British at home have continued with an extraordinary amount of digging and diving in all the British karst areas. In the Yorkshire Dales the Ireby Fell cave had its downstream sump bypassed after digging for 135 meters along a small sediment-filled passage. This dig was finally successful after 15 years of effort. In the Mendip Hills, an upper flood swallet was the major recent discovery where a dig going on since the 1960s in the final boulder choke was passed to get to a large stream passage, which is now 2.6 km long and still going. Derbyshire is dominated by Titan, a shaft in Peak Cavern, which is the largest underground pitch in Britain. This was explored initially from the bottom and only recently connected to the surface by a 40 meter deep shaft sunk mostly through solid rock.

The British have also been busy elsewhere in Europe. An annual trip to Matienzo, Spain, continues to produce 7 to 10 km each year. British cavers in the Austrian Dachstein are involved with many caves over 700 meters deep: Pig Pen 2 and Schmelzwasser Hohle, to name but two. In Crete, where there is a relatively unknown limestone with a serious depth potential, there are now 10 new caves over 100 meters deep and one over 200 meters. Further afield the British are also busy in Malaysia, India, China, Mexico, Laos, Vietnam, South America, etc.

Inside France, discoveries continue in the spectacular limestone countryside. Outside of France, the French speleologists are working in many countries. Within Europe, this includes Portugal, Macedonia, Spain, Greece, Romania, etc. Outside of Europe, they are working in Central and South America, Chile, Mexico (including the Yucatan Peninsular), Dominican Republic, Brazil, Costa Rica, Cuba, Guatemala, etc. In Asia, they are involved with China, Vietnam, Laos, Nepal, and Thailand. Elsewhere in the world, they are involved in Africa, Morocco, Madagascar, New Caledonia, and Mongolia. In 2008 alone, they had over 31 expeditions producing more than 130 km of cave passage.

Within Italy, the Italians are working with friends from Cuba on the Marmo Platano exploration and survey. Elsewhere in Europe, the Italians are working in close surrounding countries such as Slovenia, Albania, Bosnia, Greece, Turkey, Croatia, and Montenegro. Further field they are also in Spain, Georgia, and Iceland.

Outside of Europe in Central America, many Italian expeditions are visiting Cuba, and also Argentina, Honduras, Mexico, Chile, and Ecuador. In Africa, they are involved in Ethiopia, Madagascar, Tanzania, Libya, Namibia, Morocco, Algeria, Tunisia, and in the rest of the world. Italian expeditions have worked with local people in China, Syria, Myanmar (Burma), Mongolia, India, and Vietnam.

In many ways the home of speleology, Slovenia, has been the subject of many collaborative ventures. The Slovenians have worked with foreign cavers from Britain, the Czech Republic, Slovakia, Hungary, Germany, and France. Of course, they also do a lot of independent caving, particularly in the winter when you can see blow holes in melting snow. As in many other western established caving countries, a lot of cave exploration is done by digging and diving. In Slovenia, there are dives now down to 160 meters depth. There are six caves in Slovenia deeper than 1000 meters and documents on 1500 caves are sent annually to the national well-organized caving register with about 200 new cave systems added each year. Slovenia is about to implement a new cave protection law that could well be a model for the rest of the world. The Karst Research Institute of Slovenia, which provides the offices of the International Union of Speleology at Postojna, has been very involved with this legislation. The Slovenians also get involved in countries such as Montenegro, Philippines, Ukraine, the USA, and New Zealand, to name but a few. With only 7000 square kilometers of karst, Slovenia has spectacular caves and world depth potential.

I am not saying that cave exploration is alive and well in the Czech Republic but on the 8th February 2009 there was a live television broadcast of a cave being discovered in the Moravian karst. Javorika Cave is now 1150 meters long and 104 meters deep. The Czech cavers in Europe have been working in the Mesacny Tien cave in the Tatra mountains of Slovakia. It is now more than 17 kilometers long and 441 meters deep although it was only discovered in 2004. The Czechs are also in Montenegro and Sardinia.

Outside of Europe, along with several other international groups, they have worked at Krubera. In Iran, they have been involved with the longest salt cave in the world at Bandar Abbas and in the Yucatan peninsula, Sistema Jooli is now

over 6 kilometers long and all under water. The Czech and Slovak cavers continue work in Venezuela in the spectacular quartzite caves.

On the edge of Eastern Europe, the Ukrainian cavers are still very active. Within Ukraine, they have been involved with Optymisty Chan Cave, which is now nearly 250 kilometers long and firmly established as the second longest cave in the world. Nearby is Ozerma cave, which now has a total length of 128 kilometers.

3. Asia

The work abroad by the Ukrainians and Russians takes us to Asia, which for these groups has been dominated by the work in Georgia in the western Caucasus. In 2007, Krubera, which is only 50 kilometers or less from the edge of Europe, was dived at the bottom to give another 45 meters and the total depth of 2191 meters. Krubera is now, by far, the deepest cave in the world. Also in this Arabika area, Moscow cavers have pushed Iljukhina to a depth of 1273 meters. In August 2008, Russian cavers in the western Caucasus connected Iljuziyal cave with Snezhnaya cave to give a system 1753 meters deep, the second deepest in the world.

In Siberia, Russians have extended Botovskaya cave to 62 kilometers in length and in the Urals, Ordynskaya cave, which is developed in gypsum, has been extended by more than 4500 meters of underwater passage.

Many countries in Asia, including Southeast Asia, have developing local caving clubs and are doing a lot of their own exploration. I am sure there will be a lot more sharing of information at this Congress.

In China, work is being done by local cavers helped by many foreign groups, including the French, Americans, and British. In the last few years, the British China Caves Project has mapped over 100 kilometers in Guangxi and Guizhou provinces and has worked with the Anglo American Hongmeigui group, who have mapped over 300 kilometers in the last 8 years. Their achievements include exploring the spectacular vertical area of Tian Xiang in Chongqing, which has numerous 200-meters-plus shafts, and includes Miao Keng, which at 500 meters deep is the second deepest underground shaft in the world. Also, the two deepest caves in China have been explored by this group. Dongxue Xitong at -1020 meters and Da Keng at -775 meters. In Wulong county, San Wang Dong, over 41 kilometers long, and Er Wang Dong, 35 kilometers long, are the second and fifth longest caves in China.

In Guangxi province, the areas of Nandan and Leye have produced over 65 kilometers of passage including the Hongmeigui chamber, which at 200 x 300 meters is one of the largest in the world. Many large Tiankengs (dolines) have been visited in the Chongqing and Sichuan provinces

At Xinglong, the great doline and Difeng system still have to be completed, they are a great exploration challenge.

The French group PSCJA have explored Shuang He Dong to over a 114 km making it still the longest cave in China. A lot of other work has also been going on in China with the deeply incised Yangtze upper river getting particular attention. It has open shafts with over 2000 meter depth a possibility.

Longmen Dong is the longest and deepest conglomerate cave in China at over 13 kilometers long and 355 meters deep.

Local cavers are getting ever more active in both peninsular and the Borneo karst areas of Malaysia. Mulu, on the island of Borneo, still continues to yield huge quantities of magnificent cave passage. In 2005, the British explored 18 kilometers and found API chamber, which is 300 meters long and 200 meters wide. It is among the ten largest rooms in the world. A return in 2007 gave another 25 kilometers and earlier this year another expedition produced 25 more. A considerable length was added to Clearwater cave, re-establishing it firmly in the top 10 longest caves in the world. These 2009 discoveries include a huge river passage, which is a continuation of the Clearwater River. This finishes very close to the surface with the Melinau river. The lack of draft, however, suggests a surface connection may have to be dug – an excellent caving project.

In 2006, five kilometers of new passage was discovered in Laos but it is certain there is a lot more to be found. The French speleologists have had several expeditions there and work continues.

India is comparatively little known and there is undeniably a lot to go at. Megalaya in the North East, close to the Myanmar border, has been looked at many times by Anglo-Indian teams with lots of other nationalities also being involved. In 2006, 16 kilometers of cave were discovered. In 2007, another 15 kilometers, including extensions to Krem Liat Prah, made that cave in Jaintia Hills 26 kilometers long and the longest cave in India. In 2008, another 14 kilometers was added and Krem Liat Prah was connected to Krem Labbit, making the system now 31 kilometers long, ten kilometers longer than anything else on the Indian subcontinent.

Vietnam has continued to yield spectacular results close to the Chinese border, where huge caves have been known for many years, but in Vietnam they probably get even bigger. This year, a passage has been discovered that is even larger than Deer Cave in Mulu, making it the largest known cave chamber in the world. It is interesting that in 2009 speleologists can still find huge passage never before visited by anybody who realized their significance.

The Italians have been working in the spectacularly beautiful Ha Long Bay off the Vietnamese coast.

There is no doubt that Myanmar (Burma) contains a lot of cave passage. Several western expeditions have worked with the Burmese, including the French, Italians and British but these trips have tended to be little more than reconnaissance's. In the Northern and Eastern areas, the limestone looks very good but the politics are still very difficult.

Cave exploration by local and foreign groups is also going on in the Philippines with the Slovenians and Italians. Thailand, with a number of international cavers involved, and many other Asian countries, including Indonesia, Nepal, Mongolia, and Japan, are yielding enormous quantities of new caves.

4. Australasia

There are a number of caving areas in Australia, but due to the size of the country and the low population of people, they tend to be very remote. Exploration is largely on an occasional expedition basis. The Nullarbor Plain is a typical example where the annual trip by the Victorian Speleological Association uses an ultralite aircraft to find the entrances. Last year, over 200 entrances were found in a 600 square kilometer area. There is no doubt that there are an enormous number of entrances to be found. Cocklebidy Cave and several new smaller caves on the Roe Plain have been explored by divers through long underwater passages. New South Wales divers have also extended caves in Jenolan and the Wellington caves area.

In South Australia, Tank Cave, a shallow underwater system, has now been explored for more than 8 kilometers. At Mt. Gambia, divers on mixed gases are down to -124 meters. In Western Australia, the Ning Bing area of the Kimberley region has produced a number of underwater caves. Divers have gone down to 110 meters.

There are two relatively new caving areas in the Northern Territories in dolomite. The Bullita system first looked at 20 years ago now has a continuous passage length of 117 kilometers. In the same area, other caves in dolomite total 60 kilometers.

The Pungalina karst is also dolomitic. Here there is now over 40 caves, which are not easy to explore. In the wet season they are full of water and in the dry season 30°C and 100% humidity plus high CO₂. Fresh water crocodiles add extra interest.

Australia has many examples of pseudokarst solutional sandstone in the Purnululu National Park, which was inscribed as a World Heritage Site recently. There are also other known caves in Northern Australia where wind and water have produced caves in non-carbonate rocks.

As ever, a lot of caving activity is going on in North and South Islands of New Zealand. The most successful area seems to be Mount Owen with Bulmer Caverns yielding very beautiful extensions and is New Zealand's longest cave at 52 kilometers. Nettlebed at 889 meters is still the deepest cave and has been since 1986. Also on Mount Owen, Deep Thought was explored in 2007 to a depth of 422 meters. Earlier this year, an expedition to Fjordland was working above the tree line at over 1000 meters where there are caves in marble that could go down to sea level.

There have been a number of expeditions to the New Guinea islands. Irian Jaya has not been visited by speleologists recently, but there have been French and British expeditions to Papua New Guinea, New Britain, and New Caledonia. Significant cave has been explored and work done towards conserving areas and setting up protection for the caves.

5. North and Central America

The USA is obviously characterized by very long caves. Mammoth still continues to grow and, at the time of this Congress, it is likely to be over 600 kilometers long. It is very close to Fisher Ridge Cave, which is itself 180 kilometers long, and also close to Martin Ridge cave system at 55 kilometers long, so watch this space!

In South Dakota both Jewel Cave at 230 kilometers and Wind Cave 210 kilometers have had extensions. In Virginia, Omega Cave is an arduous 40 kilometers long and 385 meters deep, the deepest cave in the Eastern USA.

Lechuguilla continues to grow and is over 200 kilometers long. The nearby Big Manhole cave has a huge draft in the boulder choke and has been dug for the last 20 years. The motto here has been "breakthrough is imminent." Also in New Mexico, Fort Stanton Cave is now 22 kilometers long. A grim, long dig led to the Snowy River, which is 6 kilometers long and still going upstream and downstream. The white calcite floor in Snowy River is claimed to be the longest speleothem in the world.

Kazamura Cave in Hawaii has been pushed in the last few years to a depth of 1102 meters. It is not only the deepest cave in the USA but also the deepest lava tube in the world. It is interesting to note that this cave extends for 65 kilometers in a single nearly straight passage down the slope of Kilauea volcano. Probably this cave has the largest linear extent of any cave in the world.

A big item in Mexico is the new cave in the Naica Mine with its giant crystals. At the moment access is very difficult and one wonders what will happen when the gold mine finishes. Is there a way the pumps can continue to stop this being reflooded? In Huautla, J2 is the newest cave to go deep at 1205 meters. Zacaton is a Mexican water filled pit that was surveyed by a robotic submarine funded by NASA. Is this the way of things to come? In the Yucatan Peninsular of Mexico there are now over 310 kilometers of passage almost all under water. Sistema Ox Bel Ha at 173 kilometers and Sistema Sac Actun at 99 kilometers are two of the longest caves in the world above or below water. They are mostly flooded. The Czech speleologists have had a trip to Sistema Joolis now 6 kilometers long and again all underwater.

Things have been progressing in Canada with Castleguard Cave and Vancouver Island being looked at by British teams.

In the Caribbean, Cuba has attracted a lot of foreign expeditions with the Italians and French teams working with local cavers. French cavers have also been to Costa Rica and Guatemala. Cavers in Puerto Rico continue to extend their numerous caves complementing with scientific studies.

6. South America

In Brazil, the Toca De Boa Vista Cave is now 107 kilometers long. In Para State, there are now more than 1000 caves in iron ore, some are over a kilometer long. Guy Collet Pit in Amazonas State at 896 meters is the deepest pit in metaquartzite in the world. Aroe-jari Cave is in sandstone with speleothems over one meter long.

There is also a lot of interesting activity in other South American countries. In Paraguay there have been international expeditions with locals joined by Argentineans and Brazilians. The Italians have joined locals on trips to Patagonia in Chile and Argentina. The French have been to Patagonia Chile and also Peru. The British have explored very high caves in Peru at nearly 5000 meters altitude. At 300 meters deep, these shafts are very hard work.

Work continues in Venezuela with long and deep quartzite caves. Bolivia has had cave divers from Italy and Brazil. The

Italians have also been to Ecuador and the Atacama Desert in Chile.

7. Africa

Although there is undoubtedly an enormous amount of cave to be discovered in Africa, of all the caving continents it is probably receiving the least attention from speleologists. With the exception of South Africa, most published material on African caves and karst has been done by foreigners. The Italians have been looking at a number of karst areas in Ethiopia, Morocco, Namibia, Tunisia, Madagascar, and Tanzania. The French have been busy in at least Morocco and Madagascar. The British have continued work in Ethiopia, extending caves in Tigray, the Blue Nile basin, and the Ogaden basin in southeast of the country. The longest cave, Sof Omar, is over 15 kilometers long with the total of mapped caves in Ethiopia of less than 40 kilometers. In 2003 and 2005, the Mechara area was visited by a joint Italian-Ethiopian expedition that explored Eyefeyiti-Garayti and Rukiessa cave. A couple of trips have also been to Ethiopia looking at lava tubes and there is undoubtedly a considerable amount of volcanic speleology to be done in the future. In 2004, a highly international expedition visited Kenya and Tanzania doing excellent work helping and encouraging the local cavers.

8. Summary

In this paper I have travelled around the planet looking at some of what is going on in cave exploration. It is obvious there is still a lot left to be done. My personal guess is that only 10% of cavable caves in the world have been explored. The fact that the biggest passage in the world has been discovered in the last 6 months suggests there are world beating caves still to be found.

This sketchy overview does little more than cover some of the main areas of activity. To cover everything would have been an impossible task and produce a book rather than a lecture.

Sincere apologies to the many hard working cave explorers whose work has been omitted. Little mention has been made of cave science and other cave related activities. These, however, are vital and essential pieces of cave exploration but beyond the scope of the paper here.

Contributors:

Pavel Bosak, Rob Eavis (my son), Paolo Forte, Alexander Klimchouk, Jose Labegalini, Erin Lynch, Andrej Mihevc, Fadi Nader, Abel Vale, George Veni, Olivier Vidal, Nick White, and Paul Williams.

STATE OF THE ART IN THE SPELEOLOGICAL SCIENCES

PAOLO FORTI

Department of Geological Sciences, University of Bologna, Via Zamboni 67, 40126 Bologna Italy, paolo.forti@unibo.it

The word “speleology” usually indicates the different activities man can conduct inside caves. Speleologists are, above all, explorers. Therefore, speleology cannot be considered as a science in itself, in this context, as geology, biology, or physics are, but its practice may reveal a strong connection to the different fields of human knowledge. Cave environments, in fact, should be considered amongst the most important natural laboratories. In some cases, it is possible to complete studies and research in caves that would be absolutely impossible to do in any other place. In other instances, studies are easier and simpler when carried out in the subterranean environment. The scope of this paper includes the principal scientific research topics in caves that are or could be undertaken worldwide and to explore how it might be possible to improve scientific cave research in the near future in a quantitative and qualitative way. Finally, beyond the science itself, the most important problem that pure and applied scientific research will have to resolve is the preservation of the cave environment.

1. Introduction

The word “speleology” usually indicates all the different human activities inside caves. Speleologists are, above all, explorers and in fact most of their time underground is spent in exploring and mapping caves. There may be many other motivations that cause man to frequent the underground world from time to time; the attraction of risk and adventure, the joy of coming in contact with uncontaminated nature, and lastly, scientific research, though to a less degree. Therefore, in this context speleology cannot be considered as a science in itself, as geology, biology or physics, but its practice may reveal a strong means

of support for the different fields of human knowledge (GUNN, 2004).

Underground environments are amongst the most important natural laboratories; it is possible to complete studies and research in caves that, in some cases, would be impossible in any other place, while others are easier and simpler when carried out in the underground environment. When thinking of a scientific discipline that can take advantage of the cave environment, the first that comes to mind is geology, both in the general sense and its specific branches (hydrogeology, stratigraphy, mineralogy, etc.).

Discipline		Fields of interest
Archaeology		remains, graffiti, rock-paintings
Social Sciences		history, theology, folklore,
Biology		adaptation strategies, microbiology, chemioautotrophic environments
Physics		meteorology, climatology
Engineering		large voids, oil deposits, show caves
Medicine		speleo-therapy, physiology, psychology, psychiatry
Geology	Geomorphology	karst, speleogenesis, palaeoenvironmental reconstruction
	Geochemistry	stable isotopes, absolute dating
	Geophysics	earth tides, seismology
	Hydrogeology	karst aquifers
	Mineralogy	cave minerals, low enthalpy processes
	Palaeontology	lairs, sedimentation traps
	Sedimentology	clastic sediments, speleothems
	Stratigraphy	stratigraphical sequences
	Structural Geology	structural elements, neotectonics
	Volcanology	lava flow morphologies, deep volcanic structure

Table 1: Main pure and applied sciences interested in cave environments (after FORTI 2002, modified).

However, this identification of a cave's scientific interest for geology is limiting, contrary to what one would suppose; other fields have the same scientific interest if not even more.

Caves are underground environments characterized by a constant total absence of light and often have minimum variations of most environmental parameters (temperature, relative humidity, etc.). The rock walls that separate them from the outside world minimize, or even eliminate completely in some cases, the influence that the external climatic and/or other environmental variations can have on the cave's interior. To summarize the situation, a natural cave is generally a very stable environment, a perfect "accumulation trap" that conserves everything it collects over time. These characteristics are exploited by most scientific researchers interested in cave environments.

It would be impossible to give a complete list of all types of research that are effectively being carried out where caves are scientifically utilized. It will be sufficient to outline the most important lines of research (Table 1) and, where possible, provide some general bibliographic indications.

1.1 Archaeology

Caves have represented an environment of fundamental importance to man for an extremely long period and the use of caves as temporary or permanent homes is still cultivated in some places today. Primitive man has used caves for many different reasons: homes, cemeteries, temples, mines. Caves form a formidable and often unique archive where it's possible to find evidence particularly relative to the Paleolithic period and also of older or more recent eras. The sacred caves that maintain the most fascinating and important vestiges of prehistoric man with their graffiti and pictures couldn't have been preserved so perfectly in their delicate state until today if cave environments hadn't protected them, not only against atmospheric agents but also from human vandalism.

1.2 Social Sciences

Theology should be deeply interested in caves. In fact, the cavern environment has been fundamental for most religions. The great majority consider caves as holy places where most of the processes occurred that allow life, while others consider them devil holes. In any case, a comparative study of different religions cannot exclude the underground world.

Some of the most important events in the recent human history are directly linked to caves. For example, caves

provided saltpeter for the U.S. war of independence, which was key in defeating the English army, while the Cuban revolution had the possibility to grow and to become successful thanks to the caves in La Sierra de los Organos (NUNEZ JIMENEZ, 1987).

But caves have an even greater importance in the study of the folklore of local populations. Each nation or country has hundreds of tales, superstitions, and taboos which survive to the present. Rapa Nui Island is probably one of the best examples. The lives of the inhabitants, since the beginning of their history up to the present, is strictly related to ceremonies performed inside caves. Nowadays, anthropologists have the target of defining the recently developed extra-national aggregations (new tribes) of cavers, caving reunions, and/or associations.

1.3 Palaeontology

A great quantity of animal remains, some very ancient, have often been found in caves. Therefore it was possible to reconstruct a detailed paleo-environment that otherwise would have remained unknown. These remains are either of animals that utilized caves as dens (e.g., *hyena crocuta spelaea*, *gulo gulo*) or of prey animals. Surely the most famous large predator was the cave bear, *Ursus spelaeus*, which shared caves with cavemen, the latter being probably responsible for its extinction. However, the remains of large animals have little importance from a scientific point of view, either because they are rare or because they provide only little information about the paleo-environment and paleoclimate. The situation with the micro-mammals is quite different; these provide a highly precise reconstruction of surface climate variations. Similar studies can also be undertaken with pollen trapped in the same sediments or in speleothems.

1.4 Biology

The cave environment is, in general, hostile to life. Consequently, caves are not highly populated and the animals found there have adapted to the extreme conditions present underground through loss of pigmentation, loss of sight organs, and the lengthening of sensorial organs. Other adaptations include a reproductive strategy that only provides a small number of fully developed new beings (CULVER, 1982). Biologists are therefore extremely interested in caves in general and in the study of evolutionary steps induced by the cave environment in particular. Moreover, study of cave dwelling populations permits us to reconstruct remote environmental and climatic events when caves became shelters for animals not able to survive outside due to

changes in their ecosystem.

Presently, the most advanced cave research is microbiology. It involves the study of some peculiar and important microorganisms, like those related to the sulfur cycle, which is the basis of the deep sea food chain and gives rise to chemautotrophic ecosystems inside hypogean caves (SARBU *et al.*, 1996).

1.5 Physics

Physics is perhaps one of the first sciences to become interested in caves. In fact, in the 1600s there had already been a document published about underground meteorology. At the moment, papers on cave meteorology and climatology have a noticeable theoretic importance. Some interesting studies in this field have begun on water physics at a low temperature (BADINO, 2000). Above all, the detailed studies on underground meteorology have a much greater impact, not only practical, that is of fundamental importance in the planning, implementing, and managing of tourist caves (CIGNA *et al.*, 2000).

1.6 Geophysics

Geophysics utilizes caves in passive ways, as ideal places for measurements and experiments and in active ways by studying the response of the cave system to physical actions. In the first case, the underground environment appears ideal to investigate physical phenomena that are very slight when compared to the background noise coming from other natural or anthropogenic processes. The thickness of a cave's surrounding rock, that separates it from the outside, has an efficient isolation effect, thereby minimizing external perturbations on measurements. One example is research on earth tides, as it's impossible to measure the induced gravity variations unless they are recorded inside a cave.

Recent interest in another geophysical field involving caves is seismology and paleoseismology (QUINIF, 1998). It's been verified that caves can be amongst the most powerful natural registers of seismic waves, especially for relative high energy events which cause both breakdown and/or deflections on stalagmites' growth axes. Such studies are not only theoretically important but, even more, of practical value as they supply seismic information on the cave area in the last 600,000-800,000 years. Therefore, they enhance the estimate of seismic risk that otherwise would have to be calculated on a historic period that is absolutely insufficient if compared to geologic time.

The last field in which caves are useful for geophysical research is the study of natural emissions of radon gas, which

therefore is often present in medium to high concentrations inside caves. These studies offer an immediate practical utility, as radon can be dangerous to the human health, especially if an individual remains exposed to it for many hours a day, as in the case of the guides of show caves.

1.7 Geology

Practically all the branches of geology provide useful and often exclusive information from the cave world. Stratigraphy can easily take advantage of the vertical caves which goes down for more than 2100 meters deep inside formations which are normally, but not only carbonate. Structural geology uses caves as a powerful tool to obtain a detailed definition of the structural fabric of an area. In general, it's much easier to observe tectonic and stratigraphic elements in a cave, instead of outside where meteoric erosion often mask them. Moreover, speleogenetic mechanisms normally use the already existent discontinuities to develop galleries and other cave features, thus magnifying the original structural elements (JAKUCS, 1977).

Sediments left by cave rivers are often protected and remain unaltered for very long periods of time. It is then possible to carry out sedimentological studies that corresponding surface deposits can't always guarantee. Caves offer vast potentials for mineralogical research, since there are many minerogenetic processes potentially active in caves. Sometimes caves host also minerals exclusive to their environment (HILL & FORTI, 1997). Natural cavities are also the best places to study low enthalpy reactions which may be responsible for the genesis and diagenesis of ore bodies. During the last 10 years, calcium carbonate speleothems are revealed to be the best natural archive for the paleo-environmental and paleoclimatic reconstruction of the recent Quaternary, thereby, in some cases, permitting weather resolutions in the order of a solar year.

Geomorphology even has its own specific sector for studying processes, peculiar forms and agents that develop inside the caves and generally in karst regions (FORD & WILLIAMS, 2007). Geochemists are interested in the study of the chemistry and isotopic composition of fluid inclusions trapped within speleothems and/or speleothems themselves in order to reconstruct environmental conditions at the time of their development, and also to date them.

Hydrogeology is certainly the one field that shows the most interest in caves and the water stored there. Karst aquifers are of great importance as drinking water supplies throughout the world, representing more than 30% of the available drinking water, and up till now only a minimum

part of this reserve has been utilized (FORTI, 2002). The peculiarity of karst aquifers, derive from their extreme non-homogeneity, makes it impossible to apply the same quantitative and qualitative study methods used for porous aquifers which are essentially homogeneous. Fortunately, advanced technologies for the study and safeguard of the karst aquifers have been developing in the last few years. These results would absolutely not have been possible without the regular and constant speleological activity inside caves, which represent the natural conduit systems within karst aquifers.

Finally volcanologists can investigate the morphology and the evolution of lava flows by analyzing lava tubes. These volcanic conduits and related features are windows for easily obtaining data on magma chambers and other deep volcanic structures.

1.8 Engineering

Engineers are interested in caves for numerous reasons, some theoretical but mostly practical. Caves are a marvelous natural laboratory for engineers where they can verify some of their theories and calculations relative to “empty spaces.” One of the main engineering problems in fact, is relative to the design and excavation of large underground chambers used for many purposes (mining, geophysics laboratories, strategic controls, stockpiling of strategic and/or waste materials, etc.). Excavation of large empty spaces inside a rock mass creates the problem of pressure discharge along the wall and vault. This can be very complex to resolve through only theoretical calculations and an error could cause the entire structure to collapse. However, caves contain chambers of absolutely enormous dimensions; Sarawak Chamber in Borneo is the largest natural underground span in the world and has dimensions of about 600x400x80 m. Therefore, it’s evident how the study of equilibrium surfaces, stress monitoring of surroundings, and modeling their evolution over a short time can be of great help and save a large amount of money.

Lastly, engineering has to be considered in the complex field of planning, implementing, and managing show caves. The economical importance of the cave tourism is relevant on a worldwide scale. It provides direct and/or indirect income for 150 million people, especially in rapidly growing undeveloped countries (CIGNA *et al.*, 2000).

1.9 Medicine

The search for natural medicines, like epsomite in the prehistoric age, was one of the motivations for man to explore the depths of caves as there was no way of obtaining

it from outside. The materials people looked for in many other cases had more to do with magic than with medical science (stalagmite powder, prehistoric animal bones, moonmilk, etc.). The therapeutic use of thermal caves is very ancient, so much so, that there is a specific term for these particular activities: speleotherapy. In more recent times, east European countries have begun to also make widespread use of non-thermal, caves in order to cure allergies and infections of the respiratory tract.

Interesting studies that began in the early 1960’s involved temporal space isolation experiments taking place inside caves. They united psychologists and physiologists with speleologists who volunteered to stay inside caves for very long periods. The results demonstrated that in the absence of temporal-space reference, the vital body rhythm tends to progressively slow down passing from a daily frequency toward one based on a double cycle (48 hr).

One of the last medical disciplines to mention is pharmacology, found halfway between medicine and biochemistry. During the last couple of decades, some research groups have begun to make specific investigations in cave environments with the intention of identifying both the active ingredients to use in new medicines, and the organisms that can carry those ingredients inside our body in a selective manner.

Finally the very recent exploration of the thermal caves of Naica, Mexico, gave the opportunity for physiologists to obtain experimental data on “hyperthermia,” a deadly condition induced by high temperature and high humidity. The effects of this condition on human beings were unknown until few years ago, when the speleological exploration of Naica started.

2. Research Challenges

The importance of the cave environment in pure and applied scientific research has grown enormously during the last ten years and will surely largely increase in the near future. The most important fields in which it is reasonable to expect a noticeable rise in interest are: 1- high resolution paleoenvironmental reconstruction, 2-microbiology, and 3- special ecosystems

Caves are amongst the most lasting geomorphologic features and represent perfect sedimentological traps for physical and chemical deposits that may be kept untouched therein over long spans of time. In the last decade, caves and speleothems provided the best and most powerful information to reconstruct paleo-environments, paleo-earthquakes and

paleo-climates, sometimes allowing a resolution up to 1 measurement/year or lower. It is therefore reasonable to forecast a very fast increase of all these research topics.

In the last few years, microbiology proved to be fundamental in caves; plenty of bacteria and other micro-organisms passively and/or actively affect cave evolution. The complex biochemical reactions involved in the development of the different cave deposits, though still not completely understood, clearly have an importance far exceeding the simple speleogenetic interest (. Normally they are low-enthalpy reactions and to know about them is fundamental to improve our understanding of the natural mechanisms by which even ore bodies of economic interest are formed and then mobilized. The study of biologically driven reactions is also fundamental to enhance our knowledge over peculiar environments like the chemautotrophic ones. Thus it is reasonable to expect an increase in the co-operation between cave biologists and cave geochemists in the near future.

Some of the most important challenges for the whole of humanity will probably be solved within karst environments. Among them and worthy of mention are: 1- extensive search for new drinking water resources and, 2- new active ingredient in medicine.

The most relevant problem for future generations will surely be drinking water supplies. In fact, pollution and increase in demand are rapidly depleting many known sources for water. Karst aquifers started to be heavily utilized as civil water supplies in the last decades of the 2nd Millennium, and it is highly likely that in the near future, water in karst areas will become if not the single, then surely the most important low cost source for drinking water.

Caves should become extremely important sites for medical research. In fact, even if it is still questionable, the fact that caves could have been the “nursery” for new terrible diseases like Ebola and/or AIDS (HALLIDAY, 1999), it has been definitely demonstrated that they may host specific and, in some cases, new viruses, bacteria and/or other micro-organisms. Research started on this specific topic during the last decade and the first results suggest that the studies will be very fruitful; several hundreds of new micro-organisms and viruses have been observed in caves and some tens have been selected as potential “Trojan horses” to cure diseases and other ailments.

But the most important problem that pure and applied scientific research will have to resolve, even before

improving its use inside caves, is the preservation of the cave environment. In fact no real attention has been focused on the degradation of caves during scientific research.

3. Final Remarks

Cave environments are and will become more and more important for exciting research in plenty of scientific fields, while their importance in terms of renewable resources will be greatly enhanced. As a direct consequence of its development, scientific speleology will have to also face several hard risks for caves and karst areas. To ensure adequate preservation of caves and karst for future generations it is necessary that the speleological community voluntarily exercises worldwide control, and in some cases prohibitions, on the activities to be performed in caves on behalf of preservation. In particular, scientific oversampling must be avoided. This cautious approach should be the main target of the whole speleological scientific community in the near future.

References

- ANTONIOLI F., SILENZI S., FRISIA S. (2001) Tyrrhenian Holocene palaeoclimate trends from spelean serpulids. *Quaternary Science Reviews*, **20**(15), 1661–1670.
- BADINO G. (Ed.) (2000) *Proceedings of “Vth Int. Workshop on Glacier Caves and cryokarst in polar and high mountain regions”*, Courmayeur, Italy
- CIGNA A., CUCCHI F., FORTI P. (2000) Engineering problems in developing and managing show caves. *J. Nepal Geol. Soc.*, **22**, 85–94.
- CULVER D.C. (1982) *Cave life evolution and ecology*. Harvard University press, 189 p.
- FORD D.C., WILLIAMS P.W. (2007) *Karst Geomorphology and Hydrology*. John Wiley & Sons, Chichester, 562 p.
- FORTI P. (2002) Speleology in the Third Millennium: Achievements and Challenges. *Theoretical and Applied Karstology* **15**, 7–26.
- GUNN J. (Ed) (2004) *Encyclopedia of caves and karst science*. Fitzroy, New York, 902 p.
- HALLIDAY W.R. (1999) Overview of the 8th International Symposium on Vulcanospeleology. *Int. J. Speleol.* **27B** (1/4), 9–10 p.

Plenary Lectures

HILL C.A., FORTI P. (1997) *Cave Minerals of the World*.
Nat. Spel. Soc., Huntsville, 464 p.

JAKUCS L. (1977) *Morphogenetics in karst landforms*
Higler, Bristol, 284 p.

NUNEZ JIMENEZ A. 1987 *Geografia y Espeleologia en
Revolucion* CENFAR, La Habana, 190 p.

31

2009 ICS Proceedings

QUINIF Y. (Editor) (1998) *Karst & Tectonics*.
Speleochronos, hors serie 199 p.

SARBU S.M., KANE, T.C., KINKLE, B.K., (1996)
A chemoautotrophically based groundwater
ecosystem. *Science* **272**, 1953-1955.

UIS: THE ORGANIZATION OF INTERNATIONAL SPELEOLOGY

JOSE AYRTON LABEGALINI

ja.labegalini@uol.com.br

The acronym UIS stands for the Union Internationale de Spéléologie, in the original French. Although the name may be written differently in other languages, as International Union of Speleology in English, the original acronym is maintained. The UIS is a non-profit, non-governmental organization which promotes the development of interaction between academic and technical speleologists of a wide range of nationalities to develop and coordinate international speleology in all of its scientific, technical, cultural and economic aspects.

1. History

People have visited and used caves since prehistory, but speleology, as a new branch of science, was born a little more than a hundred years ago. Following human development, caves were used as shelters, burial places, holy places, and mines (Forti, 2001). Probably the oldest human artifacts (from *Homo habilis*) were found in Wonderwek Cave, in South Africa, from two million years ago. After thousands of years of visiting and using caves, during humanity's historical period people began to register data on caves, but speleology as a science was still far from being established. Speleology was practiced, even though the term and science were not yet "invented" (Gèze, 1993). Approximately during the middle of the contemporary Historical Period, the few people practicing speleology felt the need to organize. The year 1887, as homage to Edouard-Alfred Martel, was established as the end of the proto-historical speleological period and the start of the historical period of the speleology.

Speleology took its first steps toward recognition as a science when techniques developed at the end of the 19th Century. In the mid-1900s, the international speleological community, mostly Europeans, had the idea of holding international speleological congresses. In a meeting on August 22-23rd, 1949, in Valence-sur-Rhône, France, the decision was made to hold the first International Congress of Speleology in Paris, France, in 1953 (Pavan, 1949). Thereafter, an International Congress of Speleology (ICS) was organized every four years in a different country.

The initiative of speleologists at the 4th ICS, in 1965, led to the proposal for the creation of an international entity to bring together speleologists from all around the world and coordinate their speleological activities. The Union Internationale de Spéléologie (UIS) was founded on September 16th, 1965, during the closing session of the 4th International Congress of Speleology in the Festival Room

of the University of Ljubljana. The General Assembly of the Congress was composed by 23 delegates; from them, 22 delegates voted for the foundation of the UIS and 21 approved the first statutes. The countries with delegates in that Congress were: Austria, Belgium, Bulgaria, Congo, Czechoslovakia, Denmark, East Germany, France, Great Britain, Ireland, Italy, Japan, Lebanon, Poland, Romania, Spain, Sweden, Turkey, USA, USSR, West Germany, and Yugoslavia. The first board of officers elected was: Bernard Gèze (France) as president, Gordon T. Warwick (England) as Vice-President, Stjepan Mikulec (Yugoslavia) as second Vice-President, and Albert Anavy (Lebanon) as General Secretary. Since its foundation, the symbol adopted for representing the UIS is this one drawn in dark blue and shown on the cover of this volume.

2. Structure

At present, the UIS is presided by the following officers: a President, two Vice Presidents, a General Secretary (who is also the Treasurer), and eight Adjunct Secretaries (the number is defined by the General Assembly); each must be from a different country. These officers are elected at the general assemblies, organized at the International Congresses of Speleology. The board includes the past-presidents (without right of voting) and an invited Advisory Council. The complete list of the UIS Bureau, including the outgoing officers and past presidents, (except the first president, Bernard Gèze, who died on August 12th, 1996), is shown in Table 1.

To coordinate the technical and scientific development of international speleology, the UIS created various Departments, each one composed by Commissions and Working Groups, that have their own individual presidents and members. These groups work independently, organize their own meetings, develop projects, interact with other institutions, often publish their own bulletins, and maintain Web sites. Their presidents, however, are elected

Position	Name	Country	Address
President	Andrew James EAVIS	England	eavis@windcrown.co.uk
Vice Presidents	Alexander KLIMCHOUK	Ukraine	klim@klim.carrier.kiev.ua
	Pavel BOSAK	Czech Republic	bosak@gli.cas.cz
General Secretary	Fadi NADER	Lebanon	fadi.nader@gmail.com
Adjunct Secretaries	Andrej MIHEVC	Slovenia	andrej.mihevc@guest.arnes.si
	Carlos BENEDETTO	Argentina	benedetto@rucared.com.ar
	Efrain MERCADO	Puerto Rico	enlacepr@caribe.net
	George VENI	USA	gveni@nckri.org
	Kyung Sik WOO	Republic of Korea	wooks@kangwon.ac.kr
	Paul WILLIAMS	New Zealand	p.williams@auckland.ac.nz
	Roman HAPKA	Switzerland	roman.hapka@bluewin.ch
	Stein-Erik LAURITZEN	Norway	stein.lauritzen@geo.uib.no
Past Presidents	Arrigo A. CIGNA	Italy	arrigocigna@tiscali.it
	Adolfo ERASO ROMERO	Spain	karmenka@usal.es
	Derek C. FORD	Canada	dford@mcmaster.ca
	Hubert TRIMMEL	Austria	Hubert.Trimmel@reflex.at
	Paolo FORTI	Italy	paolo.forti@unibo.it
	Julia Mary JAMES	Australia	jmj@chem.usyd.edu.au
	José Ayrton LABEGALINI	Brazil	ja.labegalini@uol.com.br

Table 1. 2005–2009 UIS Bureau, including past presidents.

at the International Congress of Speleology and report their activities at that time. The five UIS Departments are: Department of Protection and Management (DPM), Department of Scientific Research (DSR), Department of Exploration (DE), Department of Documentation (DD), and Department of Education (DE). The complete list of Departments and their Commission and Working Groups is shown in Table 2.

Although UIS is an organization at the global level, it supports the organization and development of speleology at all the possible levels, from the caver or autonomous speleologist to speleological groups, regional organizations, national societies, and international federations (FEALC, SFEC, BSU, etc.). Figure 1 hierarchically displays the ideal interrelationship of speleological organizations in the international and respective government organizations, including the levels of publications, and the structuring of commissions and regional organizations.

3. UIS Norms and Rules

The UIS has adopted norms and policies to create and maintain its structure and to promote the development of speleology and good relationships among its member countries and with speleologists and cavers from all over the world. The UIS rules are approved by the General Assembly. Following are descriptions of the current major documents of the UIS:

15th International Congress of Speleology

UIS Statutes: The UIS Statutes were first approved in 1965 by the General Assembly of the 4th ICS, when the UIS was founded. They have been updated three times by the General Assembly of the 5th ICS (Stuttgart, Germany, 1969), 7th ICS (Sheffield, Great Britain, September, 1977), and 12th ICS (La Chaux-des-Fonds, Switzerland, 1997). During the 14th ICS (Athens, Greece, 2005), the General Assembly approved a correction of the orthography of its text.

UIS Internal Regulations: This document, the organizational core of the UIS, was adopted by the General Assembly of the 5th ICS (Stuttgart, Germany, 1969). A new version was re-written. It was approved by the current Bureau and will be submitted to the General Assembly of this ICS (Kerrville, USA, 2009).

UIS Code of Ethics: This code lacks the power of a law, but it is the recommendations of the UIS for good speleological practices by cavers all around the world. The first document was approved by the General Assembly of the 12th ICS (La Chaux-des-Fonds, Switzerland, 1997) and updated by the next General Assembly (Brasilia, Brazil, 2001).

Instructions and general recommendations for organizers of an ICS: This document, which

	Commission or Working Group	President	Country
DPM	Commission on Protection, Management and Tourism in Caves and Karstic Regions	Jean-Pierre BARTHOLEYNS	Belgium
DSR	Commission on Physics, Chemistry & Hydrogeology of Karst*	Yavor Y. SHOPOV	Bulgaria
	Commission on Paleokarst and Speleochronology	Stein-Erik LAURITZEN	Norway
	Commission on Glacier Caves and Karst in Polar Regions	Adolfo ERASO	Spain
	Commission on Volcanic Caves*	Jean Paul VAN DER PAS	Netherlands
	Working Group on Hydrothermal Karst	Yuri V. DUBLYANSKI	Russia
	Commission on Hydrogeology and Speleogenesis*	Alexander KLIMCHOUCK	Ukraine
	Commission on Cave Mineralogy*	Carol HILL	USA
	Working Group: Speleothem Protection and Conservation		
	Working Group: Bibliography	Katalin Takacsne BOLNER	Hungary
	Working Group: Mineral Ontogeny	Charlie SELF	United Kingdom
	Working Group: Speleothem Repository/Library	Paolo FORTI	Italy
	Commission on Pseudokarst	Istvan ESZTERHÁS	Hungary
	Commission on Archeology and Paleontology in Caves	R. HAPKA/D. HUBBARD	Switzerland/USA
	Commission on Speleotherapy	Svetozar DLUHOLUCKY	Slovakia
	Commission on Artificial Caves	Joep ORBONS	Nederland
DE	Commission for Cave Rescue*	Christian DODELIN	France
	Commission for Materials and Techniques	David McCLURG	EUA
	Commission for Cave Diving	Phillippe BRUNET	France
DD	Commission on Bibliography*	Patrick DERIAZ	Switzerland
	Commission for Great Caves	Luiz Carlos MEMBRADO	Spain
	Commission for the Atlas of Karstic Regions	Karl-Heinz PFEFFER	Germany
	Informatics Commission*	Peter MATTHEWS	Australia
	Working Group: Survey and Mapping*	Philipp HAUSELMANN	Switzerland
	Working Group: Karst Surface Map Symbols*	Philipp HAUSELMANN	Switzerland
	Working Group: Cave Data Exchange Format*	Peter MATTHEWS	Australia
	Working Group: Caver's Dictionary*	Mladen GARAŠIĆ	Croatia
Commission for the History of Speleology	Karl MAIS	Austria	
DE	Commission of the Teaching of Speleology	Marcel MEYSSONIER	France

* Commissions and Working Groups that maintain their own home pages, accessible through the UIS Web site

Table 2: UIS Commissions and Working Groups with respect to their Departments, Presidents, and countries.

provides the guidelines for organizing an ICS, was adopted by the General Assembly of the 5th ICS (Stuttgart, Germany, 1969). A new version was re-written, approved by the current Bureau, was used in the organization of this Congress, and will be submitted to the General Assembly of this ICS for approval (Kerrville, USA, 2009).

4. International Congress of Speleology (ICS)

Every four years, the UIS organizes the International Congresses of Speleology. Through its scientific and

technical commissions at the congresses, the UIS promotes the development of speleology in all areas of knowledge, motivates the sharing of information among speleologists and the exploration of new caves worldwide, and supports the protection of the world's speleological heritage. The International Congresses of Speleology were held in:

1st ICS - France (Paris, 1953): Planned on August 22 and 23, 1949, Valence-sur-Rhône, among French, British, Greek, Swiss and Italian speleologists

2nd ICS - Italy (Bari, 1958)

3rd ICS - Austria (Vienna, 1961)

4th ICS - Yugoslavia (Ljubljana, 1965): Foundation of the UIS and establishment of the first UIS statutes

5th ICS - Germany (Stuttgart, 1969): Approval of the UIS Internal Regulations

6th ICS - Czechoslovakia (Olomouc, 1973)

7th ICS - Great Britain (Sheffield, 1977): First ICS out of Continental Europe

8th ICS - USA (Bowling Green, Kentucky, 1981): First ICS out of Europe and first ICS in an American continent

9th ICS - Spain (Barcelona, 1986)

10th ICS - Hungary (Budapest, 1989)

11th ICS - China (Beijing, 1993): First ICS in Asia

12th ICS - Switzerland (Chaux-des-Fonds, 1997)

13th ICS - Brazil (Brasilia, 2001): First congress in the South Hemisphere and second ICS in an American Continent

14th ICS - Greece (Athens-Kalamos, 2005)

15th ICS - USA (Kerrville, Texas, 2009): The second ICS organized in the USA, first time a country organizes more than one ICS, third ICS in an American continent, and fifth out of Europe

5. Present Activities

Currently, the UIS has more than 60 member countries, located on all the continents of the world, except Antarctica, and is open to affiliation with all national associations and federations. Below are some of its major present activities.

5.1 Documentation center

Through the UIS Bibliographic Commission and in agreement with the Swiss Speleological Society (SSS), the UIS Documentation Center is maintained in the library of the SSS in La Chaux-des-Fonds. The UIS Documentation Center stores all UIS books and publications. The UIS maintains agreements with the documentation centers of many national societies and institutions to support research

and speleological development around the world. The Web site of the UIS Documentation Center is the same as the Swiss Speleological Society - www.ssslib.ch.

5.2 BBS/SA - Speleological Abstracts

In 1954, prior to the foundation of the UIS, due to the initiatives of Hubert Trimmel, the "Internationale Bibliographie für Spaeläologie Jahr 1950" was published as a supplement to "Die Höhle." In 1969, at the 5th ICS in Stuttgart, Germany, the Bibliographic Commission was founded, with the objective of collecting and publishing information in the Bulletin Bibliographique Speleologique/ Speleological Abstracts (BBS/SA), under the responsibility of Reno Bernasconi from the Swiss Speleological Society. It was established that Speleological Abstracts (also known as "Bulletin Bibliographique Spéléologique") would be written in either English or French. Its acronyms are respectively SA and BBS and used together as BBS/AS (UIS Bulletin 2, 1970). BBS/SA contains:

1. An annual compilation of worldwide publications relating to speleology (articles, journals, books, etc.);
2. From 4000 to 5000 new references per year;
3. Listing from many scientific journals (Géochronique, Ground Water, Karstologia, Journal of Hydrology, etc.) and nearly all existing caving journals;
4. Materials on all speleological subjects: karstology and geospeleology, regional speleology, biospeleology, anthrospoleology, palaeontospoleology, applied speleology, technical speleology, documentary speleology, etc.;
5. Country and author indexes;

Since 1995, the BBS/SA has been available on a CD-ROM. Speleological Abstracts continues to be the responsibility of the UIS Bibliographic Commission, whose president is Patrick Deriaz (Switzerland)

5.3 International Journal of Speleology (IJS)

The IJS is a multidisciplinary scientific publication established in 1964. Since 1978, it has been the official scientific publication of the UIS, and since 1981 it has been edited, printed and distributed by the Italian Society of Speleology in agreement with UIS. The first editorial board was composed of G. Claus (USA) and R. Husson (France). It has an international editorial board and the present editor-in-chief is Jo De Waele (Belgium). The IJS is published annually, but special topics or events can justify special editions, such as volume 28-B, dedicated to "Karst

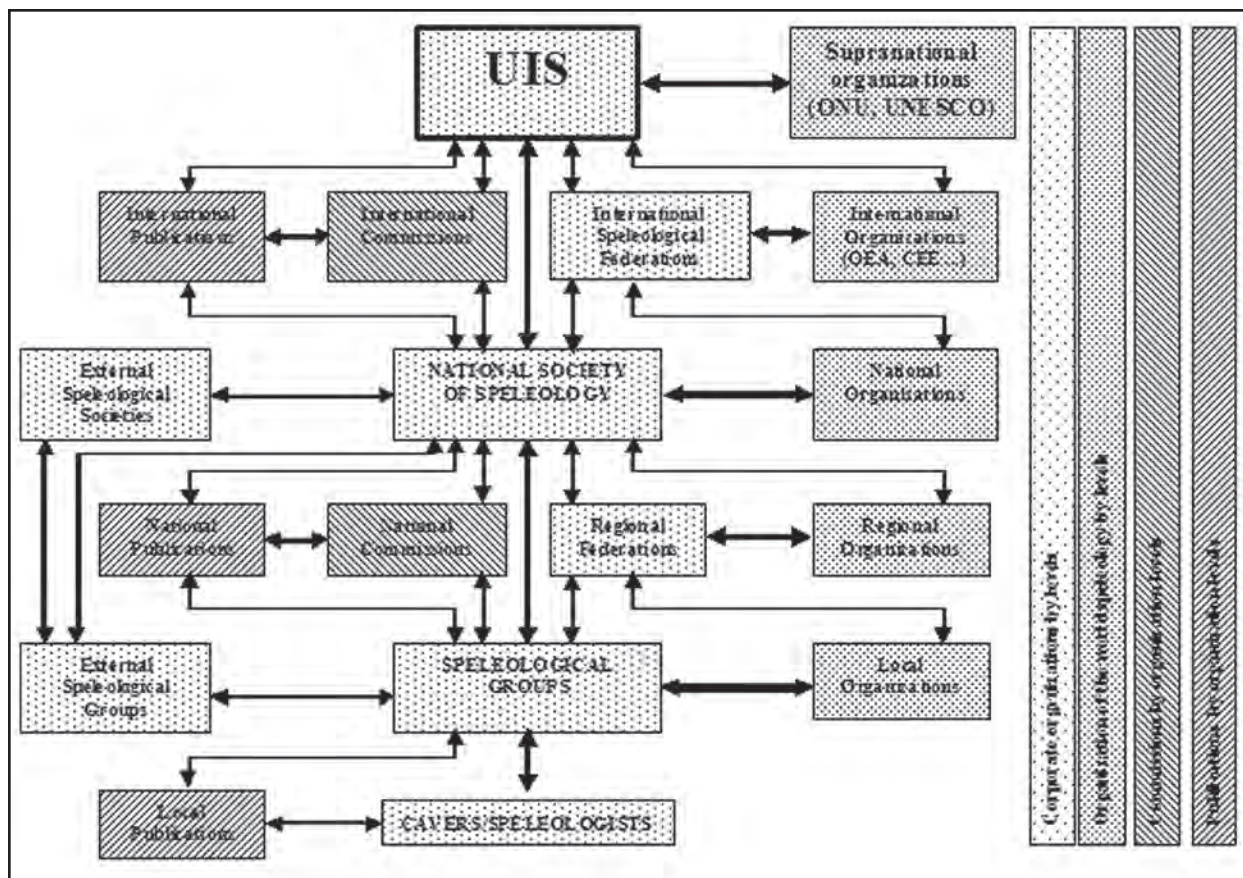

Figure 1: Outline of the relationship that a national society of speleology among the world's speleological organizations, and its ideal interrelationships with those entities (adapted from Forti, 2009).

and Agriculture in the World,” and volume 31, “Implications of Speleological Studies for Karst Subsidence Hazard Assessment.” The last issue printed was the volume 38 (1) 2009, with Cesareo Saiz-Jimenez as guest-editor. Since March 2004, the journal has been available in electronic form on the site www.ijs.speleo.it.

5.4 UIS Bulletin

The UIS-Bulletin was established at the 5th ICS (Stuttgart, Germany, 1969) to distribute news from the UIS to delegates, national organizations, etc. The collection of information, editing, layout, printing, and distribution are the responsibility of the General Secretary. The first number was printed in 1970, with the following aims and rules about its edition and distribution (UIS Bulletin 1, 1970):

1. Provide information about the activity of the UIS and its committees;
2. Provide information about the international congress (and symposia), national meetings, and scientific special issues which may be significant for several countries;
3. Provide information about the topics and work of

the committees;

4. Provide information about speleology in the member countries of the UIS, their organization and successes;
5. Publish bibliographical information;
6. Publish the official documents of the UIS;
7. Publish other information as necessary.

Since 2003, although the great majority of people and organization preferred to receive a printed copy of the UIS Bulletin, it was also made available on the UIS Web site and distributed by e-mail as a PDF or MS WORD attachment.

5.5 UIS Web site

The General Assembly of the 9th ICS (Barcelona, Spain, 1986) created the Informatics Commission with Peter Matthews (Australia) as its chairman (UIS Bulletin, 1-2/31, 1987). The proposal came from the Documentation Commission of the Australian Speleological Federation, with the perspective of facilitating the comparison, exchange and consolidation of karst and cave data among different areas of the world (UIS Bulletin, 2/30, 1986). For a long time Peter Matthews worked on his own, structuring and

managing the UIS Website. Nowadays the UIS Internet Team is composed by Manuel Freire (Portugal) as Leader, Website Manager and Calendar Editor, Erik Vdbroeck (Belgium) as Addresses Manager, Peter Matthews as Technical Manager, Stefan Näff (Switzerland) as DNS Manager and provider of the Site Host. The UIS website provides access to the UIS Statutes, Internal Regulations, Code of Ethics, issues of the UIS Bulletin, the Multi-Lingual Speleological Dictionary, the calendar of coming speleo events, a list of member countries, a list of the addresses of the officers of all the internal organizations, a list of the national delegates, and a list of the Commissions and Working Groups, as well as many links with the websites of all of the national organizations of most countries. The Web address of the UIS is: <http://www.uis-speleo.org>.

5.6 International expeditions

In 2004-2005 the UIS started organizing international expeditions to support the development of the speleology in countries where little or no speleological organization exists. The first expedition happened in Tanzania (2004-2005) and the second in Iran (2008). Other expeditions may be organized in the near future.

5.7 Headquarters

Since 2002, the UIS has its address at Tilov trg 2, 6230 Postojna, Slovenia, in the Karst Research Institute (KRI), as approved by the General Assembly of the 13th ICS (Brasilia, 2001), and as a guest of the Slovenian government.

5.8 Agreements

In order to facilitate the development of all areas of international speleology, the UIS maintains relationships with other organizations. Some of their relationships involve the signing of cooperative agreements for promoting and/or participating in international projects which can contribute to the development of speleology

5.9 Departments, commissions and working groups

At present, the UIS has five Departments, with twenty Commissions and nine Working Groups. The list of Commissions and Working Groups, with the respective presidents, their countries, and Internet address is shown in Table 2.

5.10 Outgoing bureau

The present officers (Table 1) were elected at the last general assembly in August 2005, in Athens, Kalamos, in Greece. Their term will expire at the 15th ICS and a new Bureau elected.

References

- Forti, P. (2001) *Speleology in the 3rd millennium: achievements and challenges*. Opening Lecture - 14th International Congress of Speleology, Brasilia, Brazil.
- Forti, P. (2002) Speleology in the 3rd millennium: achievements and challenges. *Theoretical & Applied Karstology*, **15**, 7-26.
- Forti, P. (2009) Porque uma só associação nacional de espeleologia? *Informativo SBE*, **93**.
- Gèze, B. (1993) Simposio Internazionale sulla Protostoria della Speleologia: p 3, Editorial
- Labegalini, J.A. (2005) *UIS: past, present and future* Opening Lecture - 14th International Congress of Speleology, Athens-Kalamos, Greece
- Pavan, M. (1949) La Réunion Internationale de spéléologie. *Rassegna Speleologica Italiana*, **1**, 2-3.

UNESCO WORLD HERITAGE CAVES AND KARST: PRESENT SITUATION, FUTURE PROSPECTS, AND MANAGEMENT REQUIREMENTS

PAUL WILLIAMS

*School of Geography, Geology & Environmental Science, Auckland University, PB 92019, Auckland, New Zealand
p.williams@auckland.ac.nz*

The World Heritage Committee considers caves and karst to be well represented on the World Heritage List, and so the scope is limited for further nominations. This paper reviews caves and karsts already represented on the World Heritage List, identifies gaps in coverage, and assesses the potential for nomination of new karst sites. It also briefly considers management issues relevant for a successful nomination.

A review of World Heritage properties shows there to be 43 with karst of international significance of which 24 are judged to be of outstanding universal value. As a first step in assessing how comprehensively these sites represent world karst, their locations are plotted on a world map of carbonate rocks and on a graph that depicts their morphoclimatic setting. This shows there to be significant gaps in (1) the geographical distribution of karst sites, representation being particularly poor in Southern Hemisphere locations and in parts of Eurasia and the Middle East; and (2) the natural environmental distribution of karst sites, there being particularly poor representation in arid, semi-arid, and periglacial environments. It is also evident that (3) karsts on evaporite rocks are totally unrepresented on the World Heritage List.

There are numerous World Heritage properties with significant karst in humid temperate and tropical regions, and many of the existing properties include outstanding caves with rich and varied biota, superb speleothem decoration and fossil-rich cave sediment accumulations, and the hydrogeological conditions under which they evolved encompasses a wide range of genetic conditions. Thus there is little scope for justifying inscription of new sites in those environments. Nevertheless, the process of nomination and inscription has been *ad hoc* and, as a result, has led to a suboptimal representation of karst values. This is apparent when considering the Dinaric Karst of Europe, the type region from which karst derives its name, the features and values of which are inadequately represented. Consequently, and assuming that Phase 2 of the South China Karst nomination will proceed, the highest priorities for completion of a comprehensive range of karst sites (including caves) are (a) to cover more adequately the karst type region of Europe, (b) to fill gaps in cold, arid and tropical oceanic regions and (c) to nominate evaporite karsts.

1. Introduction

In 1972, member states of UNESCO adopted the "Convention Concerning the Protection of the World Cultural and Natural Heritage." This is known as the World Heritage Convention and it was adopted to try to ensure the proper identification, protection, and conservation of the world's heritage. The Convention established the "World Heritage Committee" and a "World Heritage Fund" and both have been in operation since 1976. The World Heritage Committee has developed guidelines concerning the implementation of the Convention and these are revised from time-to-time (UNESCO 2008). This has been with the professional assistance of the International Union for the Conservation of Nature (IUCN), which has a formal role as the Advisory Body to the UNESCO World Heritage

Committee and makes recommendations concerning World Heritage nominations.

At a meeting of the World Heritage Committee in 2007, it was formally noted that caves and karst are well represented on the World Heritage List and that in the interests of maintaining credibility of the List there is increasingly limited scope for recommending further karst (including cave) nominations. Therefore the purpose of this paper is to review the representation of caves and karsts already on the World Heritage List and to assess the potential for nomination of new cave/karst sites by identifying significant gaps in existing coverage. The paper also briefly considers management issues relevant to the success of any future nominations.

2. Requirements of Natural World Heritage

World Heritage sites are the best of the best. They are considered to be of *outstanding universal value*, i.e. of a significance that extends far beyond the confines of the country in which the property is located, being of importance to the whole of mankind. For a potential World Heritage site to be deemed of outstanding universal value it must meet UNESCO's conditions of *integrity*, which is a measure of the wholeness and intactness of the natural heritage and its attributes, and it must also have an adequate protection and management system to ensure its safeguarding, including formal legal protection.

World Heritage sites must be accessible to the public: accessible both in terms of physical access and in terms of mental accessibility. People should be able to view, comprehend and appreciate the significance of the site, because successful long-term conservation and management depends upon public understanding of its outstanding universal value and upon on-going political support. Consequently, small areas of specialised features, the significance of which is really only understood by scientists or other specialists are not appropriate for World Heritage, even if they are extremely rare, fragile and scientifically important. To use two analogies from physical and cultural landscapes: we want the whole mountain not just the rare plants or endangered animals that it contains; we want the whole cathedral not just its exquisite stained-glass windows. These special and perhaps unique phenomena may well be eminently worthy of conservation, of course; but their safeguarding is better achieved using another convention, such as Geoparks (UNESCO 2007) in the case of geological features. Recognition of geological and geomorphological heritage outside the World Heritage Convention is discussed by Dingwall et al. (2005). We must also remember that the national park system in many countries provides excellent management and robust legal protection; so World Heritage status may bring little or no enhancement to protection, only prestige.

World Heritage is an important brand with considerable international prestige and importance for tourism. So while we may have high altruistic ideals about conservation for posterity, the principal motivation of some proponents for trying to secure World Heritage status for a site is often economic and has little to do with conservation for the sake of our children let alone our grandchildren. Nevertheless, we must be realistic, because in poorer countries this may be the only way in which investment in the management of an area and the securing of its legal protection can be obtained.

This is a kind of enlightened self-interest, and tourism can raise public awareness of the importance of a site and so can contribute to its protection, provided tourist activity is well managed and carried out in a sustainable manner.

3. Existing World Heritage Cave and Karst Properties

A review of natural World Heritage properties shows there to be 43 with karst of international significance of which 24 are judged to be of outstanding universal value. Further details concerning these properties are available in the IUCN publication "World Heritage Caves and Karst" (Williams, 2008). All the judgements are subjective and are based on the international experience of the numerous experts who have reviewed the nominations made to the World Heritage Committee. It is evident that our understanding of what might qualify as having "outstanding universal value" has evolved and become more demanding over the 30+ years since the World Heritage Convention became operative. Some of the earlier successful nominations would probably not meet the standards currently required. It is also evident that World Heritage sites have accumulated in an unsystematic, *ad hoc* manner. In the case of caves and karst, for example, no one ever asked the question: "what are the most important cave and karst sites on the planet?", and then made steps to ensure that they became represented on the World Heritage List. Instead, we accumulated sundry sites of varying significance as and when the State Parties concerned nominated them to UNESCO. So what are the most important cave and karst sites on the planet, and are they on the World Heritage List? Is there an appropriate balance in the representation of caves and karst from a range of natural environments or are some environments under-represented?

As a first step in assessing how comprehensively natural World Heritage sites represent world karst, their locations are plotted, firstly, on a world map of carbonate rocks (Figure 1) and, secondly, on a graph that depicts their environmental setting (Figure 2). This approach shows there to be significant gaps (1) in the geographical distribution of karst sites, representation being particularly poor in Southern Hemisphere locations and in parts of Eurasia and the Middle East; and (2) in the natural environmental distribution of karst sites, there being particularly poor representation in arid, semi-arid, and periglacial environments. It is also evident that (3) karsts on evaporite rocks are totally unrepresented on the World Heritage List. Nevertheless, we should not forget that the World Heritage is concerned with "outstanding universal value," and there

is no reason why regions possessing this should occur evenly across the world; thus there is no imperative to seek a uniform coverage. Some areas are better endowed with outstanding karst and caves than others.

There are numerous World Heritage properties with significant karst in humid temperate and tropical regions, and many of the existing properties include outstanding caves with rich and varied biota, superb speleothem decoration and fossil-rich cave sediment accumulations. The hydrogeological conditions under which they evolved also encompass a wide range of genetic conditions. Thus there is little scope for justifying inscription of new sites in those environments.

Nevertheless, more must be done in Europe. The *ad hoc* process of nomination has led to a suboptimal representation of karst values. This is regrettably obvious when considering the Dinaric Karst of Europe, the features and values of which are completely inadequately represented by three small sites: Plitvice Lakes (Croatia), Durmitor National Park (Montenegro) and Skocjan Caves (Slovenia). This is the region from which *karst* derives its name; the region in which the groundbreaking research of Jovan Cvijić (e.g. Cvijić 1893) was undertaken at the turn of the 19th and 20th centuries and which gave rise to modern karst science. I wonder what areas of the Dinaric Alps Cvijić would have selected to represent the natural heritage of the “Classical Karst”?

The other great karst region of the world is in southern China. The government of the Peoples’ Republic of China has taken action to conserve representative areas of this great karst area by means of a serial World Heritage nomination presented to UNESCO in 2 Phases. Phase 1, that included three important areas numbered 14 on Figures 1 and 2, was successfully concluded in 2007 and work that will lead to the nomination of several more areas in Phase 2 is underway. This is a complex nomination because it requires the support of different Provincial governments in China, but its successful outcome is of immense importance for those of us concerned with the conservation of the greatest karsts of our planet.

4. What More Needs to be Done?

Assuming that Phase 2 of the South China Karst nomination proceeds successfully, the highest priorities for completion of a comprehensive range of karst sites (including caves) are:

- (1) to cover more adequately the karst type region of

- Europe (the Dinaric Karst);
- (2) to fill gaps in cold, arid and tropical oceanic regions; and
- (3) to nominate evaporite karsts.

4.1 Dinaric Karst

A major problem in securing adequate representation of the Dinaric Karst is that it crosses several national boundaries, and some of these neighbours have not always got on very well together. However, it is encouraging to see that progress is already being made. At the 5th International ProGEO Symposium on the Conservation of Geological Heritage at Rab, Croatia, in October 2008, point 9 of the Final Declaration stated that:

We endorse cross-border cooperation between countries of karst regions with aim to develop a joint karst framework in order to achieve best practice in karst conservation and sustainable development. This is most important relative to collaboration with existing national parks and nature parks to protect parts of the Dinaric Alps karst, and to further action that will encompass karst regions of the world in accordance with the requirements for integrity and management that should apply to karst on the world heritage list.

I’m sure everyone here would wish them every success in achieving their conservation objectives and I hope the national delegates of the Dinaric countries present at this Congress take their responsibility in this matter very seriously. Cooperation is needed for the greater good, the ultimate aim being a serial transnational nomination. It would include a representative range of karst values and features of all scales above and below ground from the mountains to the sea. The nominated sites would explicitly compliment rather than duplicate the karst values already covered in the three existing World Heritage sites of the region.

4.2 Cold, arid, and tropical oceanic regions

There are only two World Heritage sites in cold regions that contain significant karst and both of these are in Canada: Nahanni National Park and the Canadian Rocky Mountain Parks (8 and 9 on Figure 1). Although these are superb and large properties it is doubtful that they represent all the attributes of caves and karst associated with cold regions. There are, for example, enormous areas of arctic Russia that contain karst that has experienced very little glaciation compared to Canada. But the region is totally unrepresented on the World Heritage List, although a nomination for the

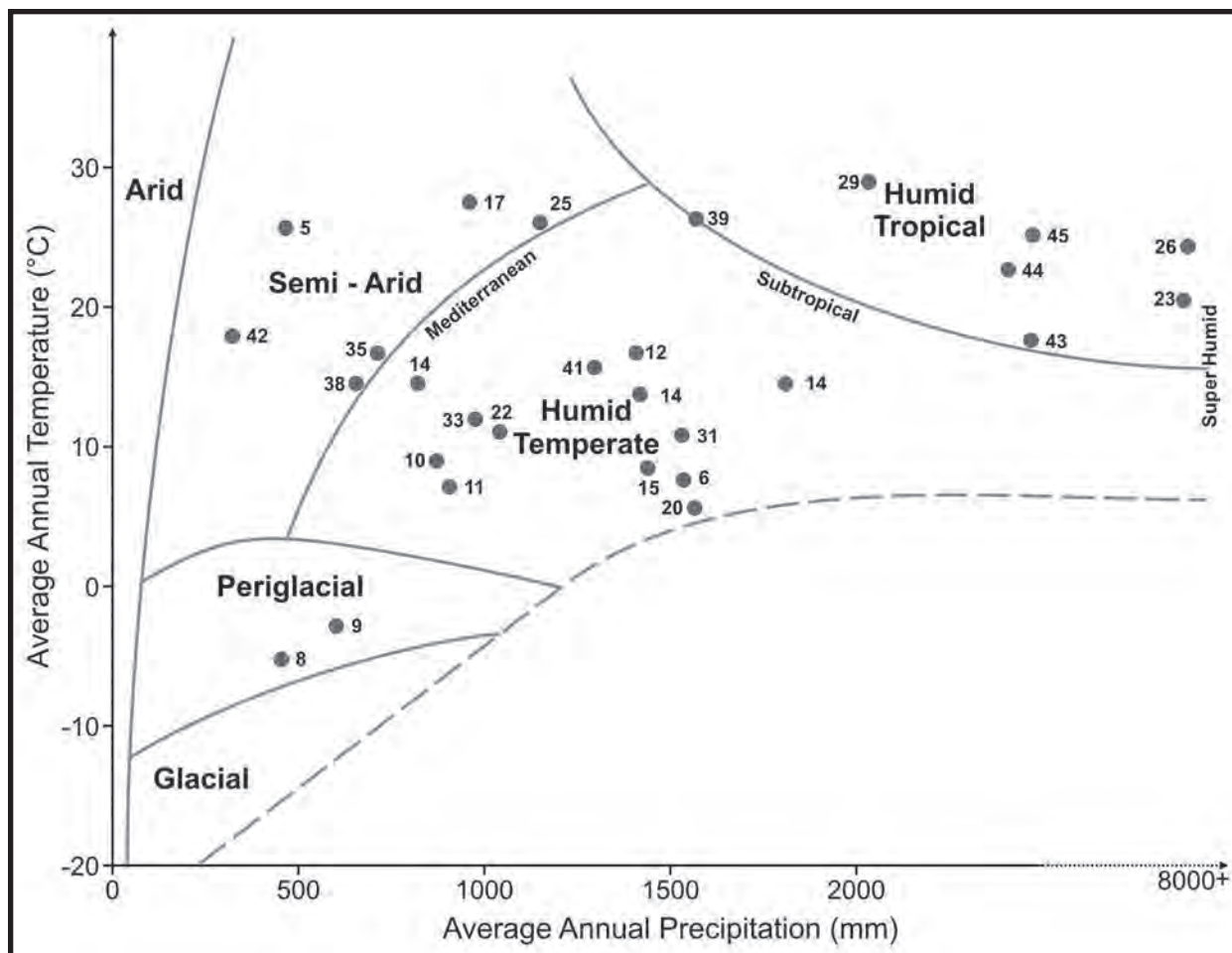

Figure 2. The climatic context of World Heritage properties with outstanding karst values (using same numbers as sites shown on Figure 1). Plotting position is approximate because some properties cover a wide range of temperature and precipitation conditions. (From Williams, 2008).

Lena Pillars is under consideration (the region contains karst, but it is not an important feature of the application).

Tropical arid and semiarid regions contain considerable karst but also are under-represented. Carlsbad Caverns National Park (USA) is the best example of a World Heritage karst site in this environment (42 on Figure 1) and it clearly has scope for expansion within the Guadalupe Mountains. The only other World Heritage karst sites in arid to semiarid regions are those that are important for their fossils rather than their karst: the Fossil Hominid Sites of Sterkfontein, Swazkrans, Kromdraai and Environs in South Africa and the Riversleigh area of the Australian Fossil Mammal Sites in tropical Queensland. There are huge areas of carbonate rock across North Africa through the Middle East and into Iran (Fig. 1), much of it with caves and karst developed under wetter climates in the past, yet the scenic and scientific importance of these areas is barely recognized. The type-site for tropical semiarid karst

landforms is in Australia; in the limestone ranges of the Kimberley in Western Australia. Australia also contains the great arid karst of the Nullarbor Plain with its well known caves. There is clearly scope for an Australian arid karsts serial nomination.

Humid tropical and subtropical karsts in continental areas are well represented on the World Heritage list, but the karsts of tropical islands are not. Although carbonate islands are small they are often of considerable scientific and scenic importance for both their biodiversity and geodiversity. Darwin made sure of that in his writings on coral reefs. Karst in coral is best expressed in uplifted coral islands, which may also be important for their calcareous aeolianite. Henderson Island (UK) in the South Pacific is the only such island on the World Heritage List (39 on Figure 1), although there are several low coral islands and reefs nominated principally for their biological values, e.g. East Rennell (Solomon Islands), Aldabra (Seychelles),

and the Great Barrier Reef (Australia). There is scope for a transnational serial nomination from low islands to high islands that would demonstrate the evolution of biodiversity and geodiversity (including caves and karst) in tropical coral islands. The best region for this would be the South Pacific and it would take into account the existing World Heritage property of Henderson Island.

4.3 Evaporite karsts

There are no evaporite karsts on the World Heritage List. This is possibly because they tend to support relatively unspectacular relief compared to carbonate karsts, despite containing very long and interesting caves such as Optimistychna Cave (214+ km) in Ukraine and Kungur Ice Cave in Russia. This is partly a consequence of the constraint imposed by relatively thin lithological sequences compared to many carbonate rocks. Nevertheless, this is not the case for the salt “glaciers” or *namakiers* of Iran, which are the spectacular surface expression of salt domes as they are extruded by lithostatic pressure and flow across the surface. There are 130 salt domes of 1–10 km across in the Southern Zagros mountains (Bosak et al. 1999, Waltham 2007) and the “glaciers” extruded from them can extend for several kilometres. Karst features including caves are well developed where salt glacier flow is not too active. A carefully selected group of sites that together demonstrate the evolution of *namakiers* and their landforms could make an excellent World Heritage nomination. Significant evaporite karst also occurs in Arctic regions in both oceanic and continental settings, such as in the Svalbard Archipelago (Norway) and in Pinega valley east of Akhangel’sk in Russia.

Thus the nomination of some important sites in evaporite rocks might also help to redress the relative absence of World Heritage properties in both arid and cold regions.

5. Management Requirements

This is an important issue for successful World Heritage nomination, because a property will only be inscribed on the World Heritage List if there is assurance that it can be safeguarded appropriately both by formal legislation and by adequate management. For a property to be deemed of outstanding universal value it must meet UNESCO’s conditions of integrity and must have an adequate protection and management system to ensure its safeguarding (UNESCO 2008). Integrity is defined as a measure of the wholeness and intactness of the natural heritage and its attributes, although the World Heritage Committee appreciates that no area is totally pristine, that activities of traditional societies often occur in natural areas,

and that where these activities are ecologically sustainable they may be consistent with the outstanding universal value of the World Heritage area.

Within a karst context the requirement for integrity implies that the natural processes which ensure the continued operation of the bio- and geo-values of the karst system are maintained and unimpeded. In practice this means that the quality and quantity of autogenic and allogenic drainage into the karst is protected, even if some of the allogenic drainage area lies beyond the proposed boundary of the nominated area. Effective legal protection will be required.

But legislation alone is not enough. An adequate protection and management system must also be in place to ensure that the key values of the proposed World Heritage property are safeguarded in practice.

6. Proposing an Area for World Heritage

Nominations are made by the government of the country to UNESCO, because the highest level of guarantee and commitment is required for the safeguarding of World Heritage properties. So cavers and scientists who consider that they have identified an area of outstanding universal value worthy of World Heritage status must make a case through formal channels in their country and request their government to send a nomination proposal to UNESCO.

Sometimes the importance of an area is first recognized by scientists and cavers on an expedition in a foreign country, and the local people and authorities may be unaware of the considerable heritage value of the property within their territory. In these cases it is necessary to bring the significance of these sites to the government concerned. This is best done using the channels provided by formal scientific associations, such as the local Academy of Science, or through the services of international scientific unions, such as the International Geological Union, International Union of Biological Sciences or the International Union of Speleology. These unions cannot be expected to make the case for you, but they can offer advice and objective scientific review. They have international standing and so their opinions and support will be taken seriously by government authorities. They can also open formal channels of communication. The first step should be to consult the report by Badman et al. (2008) *Natural World Heritage Nominations: a resource manual for practitioners*. This offers advice on what is required for a successful nomination.

References

- Badman, T., Dingwall, P. and Bomhard, B. (2008) Natural World Heritage Nominations: a resource manual for practitioners. IUCN World Heritage Studies 4, Gland, Switzerland, 40 p.
- Bosak, P., Bruthans, J., Filippi, M., Svoboda, T., and Smid, J. (1999) Karst and caves in salt diapirs, S E Zagros Mountains, Iran. *Acta Carsologica*, **28(2)**, 41–75.
- Cvijić, J. (1893) *Das Karstphänomen*. Versuch einer morphologischen Monographie, Geographische Abhandlungen herausgegeben von A. Penck, Bd., V.H, 3. Wien, p. 218–329.
- Dingwall, P., Weighell, T. and Badman, T. (2005) Geological World Heritage: a Global Framework. IUCN Protected Area Programme, 51 p.
- UNESCO (2007) Global Geoparks Network. Guidelines and Criteria for National Geoparks seeking UNESCO assistance to join three Global Geoparks Network, 10 p.
- UNESCO (2008) Operational Guidelines for the Implementation of the World Heritage Convention. UNESCO World Heritage Centre, Paris, WHC, 08/01, 163 p.
- Waltham, T. (2007) Karst and caves within the salt domes of Iran. *Cave and Karst Science*, **43(2)**, 91–96.
- Williams, P.W. (2008) World Heritage Caves and Karst: a Thematic Study. IUCN World Heritage Studies 2, Gland, Switzerland, 26 p. + 16 photos and 2 tables.

Symposium 1

ARCHAEOLOGY AND PALEONTOLOGY IN CAVES

Arranged by:
David Hubbard
Roman Hapka

MGHARET AL-HOURRIYÉ: A SPELEO-ARCHAEOLOGICAL PROJECT

HANI ABDUL-NOUR^{1,2}, SAMER AMHAZ¹, LORINE MOUAWAD¹, BADR JABBOUR-GEDEON¹

¹Association Libanaise d'Etudes Spéléologiques - ALES. P.O. Box 31, Mansourieh, Metn, Lebanon

²Scientific consultant of the Mgharet al-Hourriyé excavation

Mgharet Al-Hourriyé, a cave of great archaeological importance, was discovered by the Association Libanaise d'Etudes Spéléologiques (ALES) in 2000. Situated in the Kadisha Valley, the cave is relatively difficult to reach (a sheer 70 m cliff, a vertiginous accidental foot trail and a narrow entrance), which explains the scarceness of the anthropogenic utilization dating after the Bronze Age, to which most of the layers are related.

Three seasons of excavation (2001, 2003 and 2004) have been carried out by the archaeologists of ALES in collaboration with specialists in different disciplines from various institutions (Lebanese University, St Joseph University, American University of Beirut / Lebanon, Austria, Germany).

1. Localisation Géographique et Topographique

La grotte est située vers le fond de la vallée de la Qadisha, sur la rive droite dans le flanc Nord du Nahr Abou Ali, sous le plateau de Krabribé, en contrebas et à 600m environ au Sud – Est du monastère Notre Dame de Hamatoura, Karm Saddé, Liban. Cette cavité est creusée dans le crétacé, dans la formation géologique Cénomanién –Turonien.

Feuille topographique d'Etat Major 1/20 000° Amioun (P6)

2. Historique de la Découverte

En l'an 2000 lors d'une prospection dans la vallée de la Qadisha, une équipe de l'ALES tombe sur l'entrée d'une cavité naturelle inconnue qui contient une quantité remarquable des vestiges archéologiques. Vu la nécessité et l'urgence de sauvegarder la grotte et ces vestiges anthropiques (ossements, poteries et bois), le comité administratif de l'ALES a soumis à la Direction Générale Des Antiquités – DGA un rapport préliminaire de cette découverte.

Un décret ministériel N° 19/2001, 3 Mai 2001 autorise l'ALES de mener 3 missions de fouilles archéologiques sur une période de 3 ans.

Les difficultés d'accès, les problèmes de logistique affrontés et la complexité de site lui-même, ont pu être résolus, durant les 3 saisons de fouille 2001, 2003 et 2004, grâce à une fructueuse collaboration de différents groupes et institutions officielles et privées ainsi qu'à l'apport scientifique de spécialistes de différentes disciplines.

3. Description de la Cavité et Observation Préliminaire

L'entrée est formée de deux parties superposées de tailles différentes, la partie supérieure (15mx3m), la plus grande, elle mène à la galerie ascendante difficile d'accès et sert de pouponnière de chauves-souris. La partie inférieure de profil oblongue (1.5m x 0.5m) se déverse directement dans un puits de 4.5m, celui-ci donne accès à une galerie à profil méandrique et subhorizontale de 22m de longueur. Au fond de laquelle se trouve une cheminée de 8m qui rejoint l'étage supérieur à travers un boyau relativement étroit. La morphologie de la grotte a permis de diviser la galerie méandrique en 3 parties :

Partie I : C'est une salle de 4.5mx 1.5m localisée sous le puits d'entrée dont le sol est jonché de cailloux, de quelques morceaux de bois, et d'ossements d'animaux.

Partie II : c'est un passage horizontal étroit de 0.4m de large mène à une galerie de 12m de longueur, des vestiges archéologiques sont visibles en surface (ossements humains et animaliers, tessons de poteries, des coquilles, et beaucoup d'excréments.

Partie III : de direction NE, défendu par un ressaut oblique, le sol est parsemé de caillasses mélangés à quelque tessons de poteries.

Partie IV : c'est l'étage supérieur qui se communique avec la galerie de 22m par une cheminée de 8m. Le sol est jonché de guano et d'excréments mélangés à la terre fines. Quelques tessons de poteries se trouvent éparpillées un peu par tout.

L'observation macroscopique a décelé la présence d'une perturbation qui serait éventuellement liée à la présence des rongeurs dans la cavité. Des nids de rongeurs ont été repérés.

4. Buts de la Fouille de Mgharet al-Houriyé

- Décrypter le maximum d'informations avant la destruction du site
- Comprendre le but de l'utilisation de la grotte à travers les vestiges
- Définir la présence d'un cimetière dans une grotte très difficile d'accès
- Eclaircir sur l'apport de la spéléologie dans le domaine de l'archéologie
- Connaître l'histoire ancienne de la montagne libanaise
- Aider les jeunes locaux de comprendre l'importance de préserver leur patrimoine
- Approfondir la connaissance des spéléologues de diverses disciplines en relation avec le milieu souterrain
- Mettre en évidence l'importance de la collaboration entre secteurs privés et secteurs publics dans la réussite des projets de sauvegarde de l'héritage historique et archéologique
- Concevoir une stratégie de protection

5. Stratégie de Travail

Trois axes de travail ont été suivis en parallèle afin d'épauler la fouille à atteindre ses buts :

5.1 Travaux d'aménagement

- Aménagement d'un camp de base, sur le plateau et à plus que 2 km de la cavité, pour entreposer le matériel excavé et assurer une logistique nécessaire (des tentes équipées fournies par l'Armée Libanaise, une cuisine avec tout le nécessaire, une salle de bain et une toilette) pour rendre cet habit agréablement viable, dans cet endroit isolé, durant les saisons de fouilles.

Installation d'un éclairage dans la cavité (lumière blanche) et à l'extérieur (au camp de base) avec des groupes électrogènes et des câbles de plus de 2 km de longueur ainsi qu'un éclairage de secours alimenté par des batteries.

Montage d'un échafaudage perché dans la cavité à 50cm du sol parsemé des vestiges archéologiques avec des barres en fer réglables ancrées aux parois sur lesquelles ont été posées des planches en bois.

Fournir les différentes équipes : (équipe d'archéologues, équipe de spéléologues, et équipe du camp de base) d'un système de communication en Wireless Walkies-talkies

Aménagement des accès à la grotte : un sentier de plus que 2 km a été nettoyé et un agencement de marches a eu lieu pour assurer la voie pour les non-initiés à la technique de spéléologie alpine. Une installation de système de tyrolienne avec deux balanciers assurés le transport du matériel archéologiques le long d'une falaise de 50m et d'une pente de 100m. Installation d'une falaise de 50m avec les méthodes et équipements de spéléologie alpine. Assurer la descente du puits de 4.5m dans la grotte avec des échelles.

5.2 Technique de fouille et observation

La technique de fouille suivie est celle de Harris Matrix. La surface fouillée a été divisée en carrées de 1m chacune. L'épaisseur des couches varie de 41 cm à 51 cm.

La première campagne 2001, une surface de 7m² a été choisie dans la zone médiane là où des vestiges humains et animaliers sont visibles en surface. 0.65m ont été excavées sans arriver à la roche mère. Un sondage de 0.92m x 0.84m a eu lieu en supplémentaire avant de clôturer la saison.

La saison 2002 a été consacrée au triage, triage et classement et catalogage du matériel archéologique fouillé.

La deuxième campagne de 2003, la surface a été étendue vers la base du puits. Une technique plus affinée a été suivie dans la méthode de fouille afin de progresser la mise en valeur de la stratigraphie et d'atteindre les couches archéologiques les plus profondes.

En 2004, la troisième et la dernière campagne de fouille selon le cahier de charge signé avec la DGA. Les objectifs sont de répondre aux interrogations laissées par la fouille des campagnes précédentes ainsi d'atteindre le « bed-rock ».

5.3 Transport et équipe du camp de base

Il ne s'agit pas de l'intervention seule de l'équipe de spéléologues-archéologues de l'ALES à cette découverte, cependant, tous les membres de l'association, de disciplines différentes, ont été engagés directement aux trois campagnes

de fouilles, certains d'entre eux ont aussi collaboré dans les missions de la post-fouille.

Equipe des spéléologues-archéologues licenciés en histoire et archéologie, responsables de l'excavation, le l'inventaire, le catalogage et l'étude

Equipe de spéléologues non archéologues responsable de toutes les technicités nécessaire en spéléo-alpine pour le remontage du matériel archéologique jusqu'au camp de base. (par la voie équipée ou à dos de mule,...)

Equipe de spéléologues non archéologues et des jeunes locaux, responsable au camp de base du triage, du lavage, du marquage, du labelling et du stockage du matériel excavé. Cette équipe fut dirigée par un membre de l'ALES qui a suivi une formation spécialisée.

Equipe de spéléologues non archéologues responsable de la logistique avec une cuisinière locale.

6. Le Matériel Excavé, Analyse et Résultat.

Une série de 7 groupes de couches archéologiques d'apparence et de contenu différent a permis a livré un matériel riche et diversifié. Il comprend la céramique, des ossements humains, des objets métalliques en alliage (Copper alloy) des pièces en bois des fragments en tissus, des silex, des pierres travaillées des perles de coraline, des coquillages marins travaillés des ossement d'animaux et des escargots. Ce site est d'une importance capitale pour la connaissance de l'Histoire ancienne de la montagne libanaise. De Nombreuses questions restent encore sans réponse:

- Pourquoi le style des poteries est-il si étrangement semblable à celui de Byblos ?
- Que signifie la présence de deux rites différents d'inhumation ?
- Que fais ce bois de cèdre, daté de 4000 ans, dans la caverne ?
- Et enfin: Cette caverne étant une sépulture utilisée pendant plusieurs siècles....où donc se trouvait l'agglomération correspondante?

Ce n'est certes pas la première fois que l'on découvre une grotte naturelle contenant des vestiges de l'âge de Bronze au Liban, mais elle est de loin la mieux préservée et la plus riche. Cela est certainement dû aux difficultés de son

accès, et il est significatif qu'une équipe de spéléologues archéologues qui l'ait à la fois découverte et ait entrepris son étude.

Le grand nombre d'ossements humains, incinérés ou non, certain étant même en connexion anatomique montre à l'évidence que cette cavité était un lieu de sépulture connu deux rites différents d'inhumation : avec ou sans incinération remontant à la fin du Bronze Ancien début du Bronze Moyen, au Liban et dans les pays voisins.

Ces deux rites funéraires ont-ils été pratiqués par une seule population qui, pour des raisons quelconques ont changé de pratiques, ou s'agit-il d'un témoin de l'existence de deux populations distinctes se succèdent dans le temps et ayant utilisé la même cavité ? La stratigraphie, dans l'état actuel des fouilles, a montré l'antériorité de la pratique d'inhumation simple sur celle avec incinération. Ya-t-il eu hiatus temporel entre ces deux pratiques ?

La grande ressemblance du matériel céramique de la grotte de Hourriyé avec celle de Byblos entraine des questions sur les relations commerciales et culturelles entre ces deux sites, qui ne sont éloignés l'un de l'autre que de 25 km à vol d'oiseau. La poursuite de l'étude par une équipe pluridisciplinaire pourraient éventuellement répondre à ces questions.

Avant de quitter le chantier, la zone de fouille est recouverte par du géotextile et d'un filet en métal inoxydable pour empêcher toute perturbation animale en attendant la réouverture du chantier dans quelques années

Seul 30% du gisement a été fouillé, ce qui a donné plus de 500 kg de matériel céramique a étudier A la fin de la campagne de fouilles de 2004, une porte métallique a été installée à l'entrée de la cavité en guise de protection, car il faudra attendre quelques années avant de continuer ...Double protection: des barbelés installés par l'armée....

Ce projet n'aurait pas été possible sans la collaboration active de plusieurs parties nous citons les plus importants:

Secteur Privé

- Mr Ghassan Tayoun : Europtima Group s.a.r.l.

- Monastère Hamatoura Pour les Grecs Orthodoxe

Secteur public

- La DGA

- Armée Libanaise

- Municipalité de Karm Saddeh & son Président
Cheikh Khalil El Houry

Donateurs:

- Europtima Group s.a.r.l.

- Cheikh Pierre al Daher

- Municipalité de Karm Saddeh

- Union municipalités de Sahel Zgharta

- Fares Foundation

On ne peut qu'être très reconnaissant pour la dédication et les sacrifices des membres de l'ALES, des archéologues de l'université Libanaise, des membres du Spéléo Club de Wadi al Aarayech des jeunes de Karm Saddeh qui, sans eux ce projet n'aurait pas été possible.

Equipe de spécialistes :

Carola Berszin, Antropologue physique, Landesdenkmalamt
Baden-Württemberg, Arbeitsstelle Osteologie, Konstanz,
Allemagne

Raymond Gèze, étude géomorphologique et ossements
(Université Libanaise – Liban)

Hani Abdul-Nour et Najla Zeidan Gèze, Faune souterraine
(Université Libanaise – Liban)

Otto Cichocki, Dendrochronologie et datation C₁₄
(Vienna Institut for Archaeological Science, Autriche)

Corine Yazbeck, outillage lithique (Université Saint Joseph,
Liban)

MGHARET AL-HOURRIYÉ: A SPELEO-ARCHAEOLOGICAL PROJECT

HANI ABDUL-NOUR^{1,2}

SAMER AMHAZ¹

LORINE MOUAWAD¹

BADR JABBOUR-GEDEON¹

¹*Association Libanaise d'Etudes Spéléologiques - ALES. P.O. Box 31,
Mansourieh, Metn, Lebanon*

²*Scientific consultant of the Mgharet al-Hourriyé excavation*

Mgharet Al-Hourriyé, a cave of great archaeological importance, was discovered by the Association Libanaise d'Etudes Spéléologiques (ALES) in 2000. Situated in the Kadisha Valley, the cave is relatively difficult to reach (a sheer 70 m cliff, a vertiginous accidental foot trail and a narrow entrance), which explains the scarceness of the anthropogenic utilization dating after the Bronze Age, to which most of the layers are related.

Three seasons of excavation (2001, 2003 and 2004) have been carried out by the archaeologists of ALES in collaboration with specialists in different disciplines from various institutions (Lebanese University, St Joseph University, American University of Beirut / Lebanon, Austria, Germany).

1. Localisation géographique et topographique

La grotte est située vers le fond de la vallée de la Qadisha, sur la rive droite dans le flanc Nord du Nahr Abou Ali, sous le plateau de Krabribé, en contrebas et à 600m environ au Sud – Est du monastère Notre Dame de Hamatoura, Karm Saddé, Liban. Cette cavité est creusée dans le crétacé, dans la formation géologique Cénomanién –Turonien. Feuille topographique d'Etat Major 1/20 000° Amioun (P6)

2. Historique de la découverte

En l'an 2000 lors d'une prospection dans la vallée de la Qadisha, une équipe de l'ALES tombe sur l'entrée d'une cavité naturelle inconnue qui contient une quantité remarquable des vestiges archéologiques. Vu la nécessité et l'urgence de sauvegarder la grotte et ces vestiges anthropiques (ossements, poteries et bois), le comité administratif de l'ALES a soumis à la Direction Générale Des Antiquités – DGA un rapport préliminaire de cette découverte.

Un décret ministériel N° 19/2001, 3 Mai 2001 autorise l'ALES de mener 3 missions de fouilles archéologiques sur une période de 3 ans.

Les difficultés d'accès, les problèmes de logistique affrontés et la complexité de site lui-même, ont pu être résolus, durant les 3 saisons de fouille 2001, 2003 et 2004, grâce à une fructueuse collaboration de différents groupes et institutions officielles et privées ainsi qu'à l'apport scientifique de spécialistes de différentes disciplines.

3. Description de la cavité et observation préliminaire

L'entrée est formée de deux parties superposées de tailles différentes, la partie supérieure (15mx3m), la plus grande, elle mène à la galerie ascendante difficile d'accès et sert de pouponnière de chauves-souris. La partie inférieure de profil oblongue (1.5m x 0.5m) se déverse directement dans un puits de 4.5m, celui-ci donne accès à une galerie à profil méandrique et subhorizontale de 22m de longueur. Au fond de laquelle se trouve une cheminée de 8m qui rejoint l'étage supérieur à travers un boyau relativement étroit.

La morphologie de la grotte a permis de diviser la galerie méandrique en 3 parties (BEAYNO, et al., 2004):

Partie I : C'est une salle de 4.5mx 1.5m localisée sous le puits d'entrée dont le sol est jonché de cailloux, de quelques morceaux de bois, et d'ossements d'animaux.

Partie II : c'est un passage horizontal étroit de 0.4m de large mène à une galerie de 12m de longueur, des vestiges archéologiques sont visibles en surface (ossements humains et animaliers, tessons de poteries, des coquilles, et beaucoup d'excréments).

Partie III : de direction NE, défendu par un ressaut oblique, le sol est parsemé de caillasses mélangés à quelques tessons de poteries.

Partie IV : c'est l'étage supérieur qui se communique avec la galerie de 22m par une cheminée de 8m. Le sol est jonché de guano et d'excréments mélangés à la terre fines. Quelques tessons de poteries se trouvent éparpillés un peu par tout. L'observation macroscopique a décelé la présence d'une perturbation qui serait éventuellement liée à la présence des rongeurs dans la cavité. Des nids de rongeurs ont été repérés.

4. Buts de la fouille de Mgharet al-Houriyé

- Décrypter le maximum d'informations avant la destruction du site
- Comprendre le but de l'utilisation de la grotte à travers les vestiges
- Définir la présence d'un cimetière dans une grotte très difficile d'accès
- Eclaircir sur l'apport de la spéléologie dans le domaine de l'archéologie
- Connaître l'histoire ancienne de la montagne libanaise
- Aider les jeunes locaux de comprendre l'importance de préserver leur patrimoine
- Approfondir la connaissance des spéléologues de diverses disciplines en relation avec le milieu souterrain
- Mettre en évidence l'importance de la collaboration entre secteurs privés et secteurs publics dans la réussite des projets de sauvegarde de l'héritage historique et archéologique
- Concevoir une stratégie de protection

5. Stratégie de travail

Trois axes de travail ont été suivi en parallèle afin d'épauler la fouille à atteindre ses buts :

Travaux d'aménagement (ABDUL-NOUR, 2004)

- Aménagement d'un camp de base, sur le plateau et à plus que 2 km de la cavité, pour entreposer le matériel excavé et assurer une logistique nécessaire (des tentes équipées fournies par l'Armée Libanaise, une cuisine avec tout le nécessaire, une salle de bain et une toilette) pour rendre cet habit agréablement viable, dans cet endroit isolé, durant les saisons de fouilles.
- Installation d'un éclairage dans la cavité (lumière blanche) et à l'extérieur (au camp de base) avec des groupes électrogènes et des câbles de plus 2 km de longueur ainsi qu'un éclairage de secours alimenté par des batteries.
- Montage d'un échafaudage perché dans la cavité à 50cm du sol parsemé des vestiges archéologiques avec des barres en fer réglables ancrées aux parois sur lesquelles ont été posées des planches en bois.
- Fournir les différentes équipes : (équipe d'archéologues, équipe de spéléologues, et équipe du camp de base) d'un système de communication en Wireless Walkies-talkies
- Aménagement des accès à la grotte : un sentier de plus que 2 km a été nettoyé et un agencement de marches a eu lieu pour assurer la voie pour les non-initié à la technique de spéléologie alpine. Une installation de système de tyrolienne avec deux balanciers assuré le transport du matériel archéologiques le long d'une falaise de 50m et d'une pente de 100m. Installation d'une falaise de 50m avec les méthodes et équipements de spéléologie alpine. Assurer la descente du puits de 4.5m dans la grotte avec des échelles.

Technique de fouille et observation

La technique de fouille suivie est celle de Harris Matrix. La surface fouillée a été divisée en carrées de 1m chacun. L'épaisseur des couches varie de 41 cm à 51 cm (BEAYNO et Mattar, 2004).

- La première campagne 2001, une surface de 7m² a été choisie dans la zone médiane là où des vestiges humains et animaliers sont visibles en surface. 0.65m ont été excavée sans arriver à la roche mère. Un sondage de 0.92m x 0.84m a eu lieu en supplémentaire avant de clôturer la saison.
- La saison 2002 a été consacrée au triage, triage et classement et catalogage du matériel archéologique fouillé.
- La deuxième campagne de 2003, la surface a été étendue vers la base du puits. Une technique plus affinée a été suivie dans la méthode de fouille afin de progresser la mise en valeur de la stratigraphie et d'atteindre les couches archéologiques les plus profondes.
- En 2004, la troisième et la dernière campagne de fouille selon le cahier de charge signé avec la DGA. Les objectifs sont de répondre aux interrogations laissées par la fouille des campagnes précédentes ainsi d'atteindre le « bed-rock ».

Transport et équipe du camp de base (ABDUL-NOUR et al, 2004)

Il ne s'agit pas de l'intervention seule de l'équipe de spéléologues-archéologues de l'ALES à cette découverte, cependant, tous les membres de l'association, de disciplines différentes, ont été engagés directement aux trois campagnes de fouilles, certains d'entre eux ont aussi collaboré dans les missions de la post-fouille.

- Equipe des spéléologues-archéologues licenciés en histoire et archéologie, responsables de l'excavation, le l'inventaire, le catalogage et l'étude
- Equipe de spéléologues non archéologues responsable de toutes les technicités nécessaire en spéléo-alpine pour le remontage du matériel archéologique jusqu'au camp de base. (par la voie équipée ou à dos de mule,...)
- Equipe de spéléologues non archéologues et des jeunes locaux, responsable au camp de base du triage, du lavage, du marquage, du labelling et du stockage du matériel excavé. Cette équipe fut dirigée par un membre de l'ALES qui a suivi une formation spécialisée.
- Equipe de spéléologues non archéologues responsable de la logistique avec une cuisinière locale.

6. Le matériel excavé, analyse et résultat.

Une série de 7 groupes de couches archéologiques d'apparence et de contenu différent a permis de livrer un matériel riche et diversifié. Il comprend la céramique, des ossements humains, des objets métalliques en alliage (Copper alloy) des pièces en bois des fragments en tissus, des silex, des pierres travaillées des perles de corail, des coquillages marins travaillés des ossements d'animaux et des escargots (BEAYNO et al., 2004).

Ce site est d'une importance capitale pour la connaissance de l'Histoire ancienne de la montagne libanaise...

De nombreuses questions restent encore sans réponse:

- Pourquoi le style des poteries est-il si étrangement semblable à celui de Byblos ?
 - Que signifie la présence de deux rites différents d'inhumation ?
 - Que fait ce bois de cèdre, daté de 4000 ans, dans la caverne ?
 - Et enfin: Cette caverne étant une sépulture utilisée pendant plusieurs siècles...où donc se trouvait l'agglomération correspondante?

Ce n'est certes pas la première fois que l'on découvre une grotte naturelle contenant des vestiges de l'âge de Bronze au Liban, mais elle est de loin la mieux préservée et la plus riche. Cela est certainement dû aux difficultés de son accès, et il est significatif qu'une équipe de spéléologues archéologues qui l'a à la fois découvert et ait entrepris son étude.

Le grand nombre d'ossements humains, incinérés ou non, certains étant même en connexion anatomique montre à l'évidence que cette cavité était un lieu de sépulture connu deux rites différents d'inhumation : avec ou sans incinération remontant à la fin du Bronze Ancien début du Bronze Moyen, au Liban et dans les pays voisins

Ces deux rites funéraires ont-ils été pratiqués par une seule population qui, pour des raisons quelconques ont changé de pratiques, ou s'agit-il d'un témoin de l'existence de deux populations distinctes se succédant dans le temps et ayant utilisé la même cavité ? La stratigraphie, dans l'état actuel des fouilles, a montré l'antériorité de la pratique d'inhumation simple sur celle avec incinération. Ya-t-il eu hiatus temporel entre ces deux pratiques ?

La grande ressemblance du matériel céramique de la grotte de Hourriyé avec celle de Byblos entraîne des questions sur les relations commerciales et culturelles entre ces deux sites, qui ne sont éloignés l'un de l'autre que de 25 km à vol d'oiseau. La poursuite de l'étude par une équipe pluridisciplinaire pourraient éventuellement répondre à ces questions (BEAYNO et Mattar, 2004).

Avant de quitter le chantier, la zone de fouille est recouverte par du géotextile et d'un filet en métal inoxydable pour empêcher toute perturbation animale en attendant la réouverture du chantier dans quelques années

Seul 30% du gisement a été fouillé, ce qui a donné plus de 500 kg de matériel céramique à étudier. A la fin de la campagne de fouilles de 2004, une porte métallique a été installée à l'entrée de la cavité en guise de protection, car il faudra attendre quelques années avant de continuer ...

Double protection: des barbelés installés par l'armée....

Ce projet n'aurait pas été possible sans la collaboration active de plusieurs parties nous citons les plus importants:

Secteur Privé

- Mr Ghassan Tayoun : Europtima Group s.a.r.l.
- Monastère Hamatoura Pour les Grecs Orthodoxe

Secteur public

- La DGA
 - Armée Libanaise
 - Municipalité de Karm Saddeh & son Président Cheikh Khalil El Houry

Donateurs:

- Europtima Group s.a.r.l.
- Cheikh Pierre al Daher
- Municipalité de Karm Saddeh
- Union municipalités de Sahel Zgharta
- Fares Foundation

On ne peut qu'être très reconnaissant pour la dédication et les sacrifices des membres de l'ALES, des archéologues de l'université Libanaise, des membres du Spéléo Club de Wadi al Aarayech des jeunes de Karm Saddeh qui, sans eux ce projet n'aurait pas été possible.

Equipe de spécialistes :

Carola Berszin, Anthropologue physique, Landesdenmalamt Baden-Württemberg, Arbeitsstelle Osteologie, Konstanz, Allemagne

Raymond Gèze, étude géomorphologique et ossements (Université Libanaise – Liban)

Hani Abdul-Nour et Najla Zeidan Gèze, Faune souterraine (Université Libanaise – Liban)

Otto Cichocki, Dendrochronologie et datation C₁₄ (Vienna Institut for Archaeological Science, Autriche)

Corine Yazbeck, outillage lithique (Université Saint Joseph, Liban)

Références

- BEAYNO F., MATTAR C., et ABDUL-NOUR H., (2004), « Magharet al Hourriyé (Karm Saddé, Caza de Zgharta). Rapport préliminaire de la première campagne de fouille » Baal, 6, 2002, p.133-176.
- ABDUL-NOUR H., (2004), « Une aventure pas comme les autres : Mgharet Al-Hourriyé ». SPELEORIENT, 4, 2004, p.16-32
- BEAYNO F., et C. MATTAR, (2004), « Mgharet al Hourriyé : Sépulture collective de l'âge du Bronze dans une caverne de la Qadisha », Decade, (1995-2004), p. 426-447.

A DENDROARCHAEOLOGICAL APPROACH TO UNDERSTANDING THE NINETEENTH CENTURY SALTPETER-MINING INDUSTRY IN THE SOUTHEASTERN UNITED STATES

SARAH A. BLANKENSHIP¹, HENRI D. GRISSINO-MAYER¹

¹Department of Anthropology, 250 S. Stadium Hall, University of Tennessee, Knoxville, TN, 37996 USA

²Laboratory of Tree-Ring Science, Department of Geography, University of Tennessee, Knoxville, TN, 37996 USA

During the nineteenth century, the increasing demand for saltpeter, a vital ingredient in gunpowder, led to both large- and small-scale saltpeter-mining operations in caves throughout the southeastern region of the United States. Although the general procedures in the historic processing of saltpeter are fairly well understood, very little archaeological research has been undertaken on specific saltpeter-mining sites. Historic documentation of mining activities within these caves is scarce, thus systematic studies of these sites are integral to a greater understanding of this early extractive industry. The research presented in this paper is the first in the region in which archaeological and dendrochronological investigations were used in conjunction in an attempt to remedy this absence of formal study.

The dry environment of saltpeter caves allows for excellent preservation of the material record, thus a number of saltpeter-mining sites still contain the equipment used in the mining operations, much of it still in context. The subject of this study, Cagle Saltpetre Cave, in Van Buren County, Tennessee, is one such site. During the mining episodes at Cagle Saltpetre Cave, wooden leaching vats needed for the lixiviation of saltpeter from mined sediments were constructed and used within the cave. When mining operations ceased, these artifacts were abandoned and preserved *in situ*, some remaining virtually intact. Their remarkable preservation enabled tree-ring dating of timbers associated with these artifacts. The results of these analyses indicate that saltpeter was mined and processed on site at various times throughout the nineteenth century. When considered in conjunction with the extant historical data on the saltpeter-mining industry, these dates indicate that Cagle Saltpetre Cave, in addition to other remote southeastern U.S. caves, was likely mined in response to both local and global politico-economic pressures.

1. Introduction

For centuries, the recipe for gunpowder consisted of the following ingredients (often in varying quantities): seventy-five parts saltpeter, ten parts sulfur and fifteen parts charcoal. Of the three ingredients, saltpeter (derived from the Latin *sal petrae*, meaning “salt of rock”), is arguably the most critical, as it gives gunpowder its explosive properties. In comparison to sulphur and charcoal, saltpeter also has required the most effort to obtain. Due to the high solubility of saltpeter (and other nitrate minerals referred to as saltpeter) (HILL, 1981), there are few deposits on the Earth’s surface that contain the quantities needed to sustain the manufacture of gunpowder at a large scale. Prior to the development of nitrogen-fixation technologies during the first part of the twentieth century, the nitrate-rich sediments found in the many dry caves of the southeastern region of the U.S. proved to be some of the most reliable, domestic sources for the production of saltpeter.

A variety of nitrate minerals have been identified in

cave saltpeter deposits, and include (HILL, 1977: 127; HILL and FORTI 1997: 157-162): niter (KNO_3), soda-niter (NaNO_3), ammonia-niter (NH_4NO_3), darapskite ($\text{Na}(\text{NO}_3)(\text{SO}_4 \bullet \text{H}_2\text{O})$), nitromagnesite ($\text{Mg}(\text{NO}_3)_2 \bullet 6\text{H}_2\text{O}$) and nitrocalcite ($\text{Ca}(\text{NO}_3)_2 \bullet 4\text{H}_2\text{O}$). The hygroscopic and deliquescent nature of the latter nitrate minerals (HILL, 1977: 127; HILL and FORTI 1997: 159, 161-162) required their conversion to niter (potassium nitrate), which is less deliquescent; therefore certain procedures were followed when mining and processing cave saltpeter (BLANKENSHIP, 2007: 20; see also, ELLER, 1981; LECONTE, 1862; RAINS, 1862; SMITH, 1990):

- (1) Leaching vats or hoppers were constructed near a water source either inside or outside of the cave.
- (2) The leaching vats were filled with mined cave sediments.
- (3) To lixiviate the nitrates, water was poured onto the vats one or more times and the resulting nitrate-rich leachate was collected in troughs.

- (4) The leachate was combined with potash (i.e., wood ash) lye to chemically convert the nitrate solution to a potassium nitrate solution. The chemical conversion involves the removal of calcium and magnesium from the solution by the potash lye (potassium hydroxide [KOH]) through the precipitation of the insoluble hydroxides of calcium (Ca) and magnesium (Mg), as expressed in the following equation (ELLER, 1981: 106): $[Ca^{+}, Mg^{+}, NH_4^{+}] (NO_3) \text{ solution} + KOH \rightarrow K^{+} + NH_4^{+} + [NO_3]^{-} + Ca(OH)_2 + Mg(OH)_2$
- (5) The potassium nitrate solution was then filtered and impurities such as lime and/or sulfates (which are soluble at relatively low temperatures [ELLER, 1981: 107]) were removed by boiling the solution.
- (6) The refined solution was allowed to cool in order for the nitrate crystals to form.
- (7) The nitrate crystals were then collected, dried, packed, and sent to the powder mills.

Prior to the development of modern gunpowder manufacturing technologies, the American colonies—and later, United States—relied heavily on the importation of saltpeter from British India. However, fluctuations in the overseas market, due in large part to European military campaigns and the often unstable relations among the United States and European powers, often interrupted the supply of imported saltpeter for munitions. Sustainable domestic production of saltpeter therefore became essential. Because large quantities of saltpeter naturally occur in some caves, these subterranean locales became invaluable to the domestic munitions industry. However, it is uncertain as to when saltpeter was first obtained from America's caves; the earliest records indicate that the intensive mining of cave nitrates likely began in Virginia during the late eighteenth century (DOUGLAS, 2001; FAUST, 1964; HOVEY, 1897; POWERS, 1981), as the rising demand (and price) for the commodity just prior to the American Revolutionary War led to the emergence of the widespread, if fragmented, domestic saltpeter mining and processing industry (for a more in-depth discussion of the historical development of the U.S. saltpeter industry see: BLANKENSHIP, 2007, 2008; DOUGLAS, 2001). The dry environment typical of the saltpeter caves of the southeastern U.S. allows for excellent preservation of the material record, thus some saltpeter-mining cave sites still contain the equipment used in the mining operations, at times still in primary context. The subject of this study, Cagle Saltpetre Cave in Tennessee, USA, is one such site.

2. Site Description and Summary of Dendroarchaeological Research

Cagle Saltpetre Cave is located in Van Buren County, Tennessee, and lies along the western escarpment of the Cumberland Plateau physiographic province, which is the southern portion of the Appalachian Plateaus structural province of the eastern U.S. (as defined by FENNEMAN [1938] and MILLER [1994]). The cave has a surveyed length of 368 m and a total depth of 30 m and consists of two main levels and three primary passages that extend to the west, south, and southeast from the lower level (Fig. 1). The entrance to the cave is located at the contact of the Upper Mississippian-age Hartselle Formation (consisting primarily of greenish-gray to yellowish-brown, fine-grained sandstone [HARDEMAN, 1966]) and the underlying Monteagle Limestone. The cave is formed entirely within the Monteagle formation, which is a gray, micrograined to coarse-grained, thick-bedded limestone (HARDEMAN, 1966).

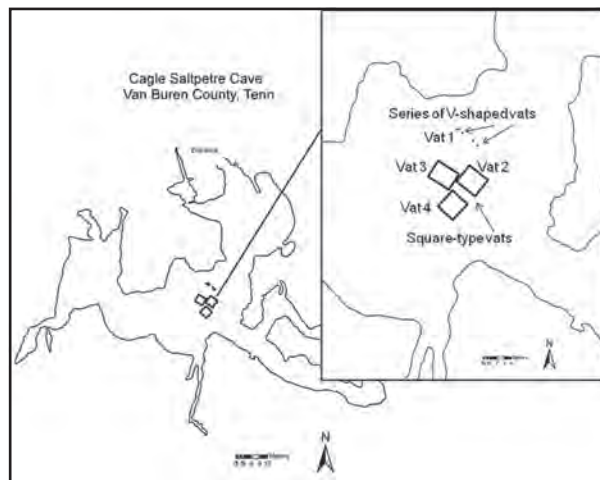

Figure 1: Plan view map of Cagle Saltpetre Cave, showing the locations of the V-shaped vats and square-type vats discussed in this study (from, BLANKENSHIP et al., 2009: Figure 2).

The archaeological survey of Cagle Saltpetre Cave (BLANKENSHIP, 2007, 2008) identified the remains of four extant leaching vats, located in the lower level of the cave (see Fig. 1), that were used in the historic saltpeter operations; all are fairly well-preserved and remain *in situ*. Three of the vats are of the “square-type” or “box-style” construction (designated Vats 2–4) and overlie the remaining vat, which is “V-shaped” (designated Vat 1) (detailed descriptions of these general vat forms can be found in: DUNCAN, 1995: 55; FAUST, 1955: 14-16, 1967: 48-59). Examples of the square-type and V-shaped leaching vats at Cagle Saltpetre Cave are shown in Figure 2. Their remarkable preservation enabled the application of tree-ring dating (i.e., dendrochronology) of white oak (*Quercus alba* L.) timbers used in their construction (for

a detailed report of the dendrochronological methods and analyses employed, including descriptive statistics, see: BLANKENSHIP et al., 2009). The final chronology developed from the 39 dated series sampled from the Cagle Saltpetre Cave leaching vats was shown to be highly correlated ($p < 0.0001$) with the Norris Dam State Park white oak reference chronology from Anderson County, Tennessee, USA

(DUVICK, 1981) that spans the period AD 1633 to 1980 (BLANKENSHIP et al., 2009: 15) (Fig. 3). These results verified that our site chronology extends from AD 1692 to 1861 (BLANKENSHIP et al., 2009: Table 1). From these analyses, cutting dates were established for the preserved leaching vats, which were found to cluster on four discrete dates: Vat 1, the V-shaped vat, dates to AD 1811; Vat 3, a square-type vat, dates to AD 1854; Vat 4, a square-type vat, dates to AD 1860; and Vat 2, a square-type vat, dates to AD 1861 (see also, BLANKENSHIP et al., 2009: 17, Table 1). To date, no historic documents exist that concern the

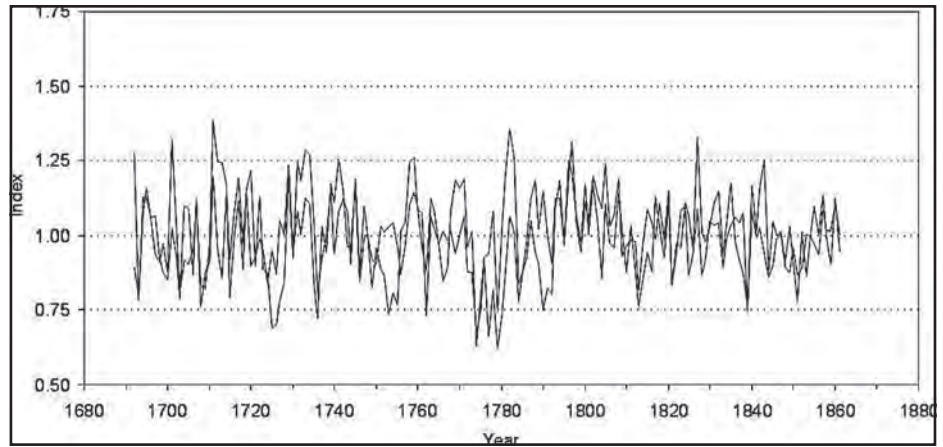

Figure 3: Comparison of the Norris Dam State Park white oak reference chronology (gray line) and the Cagle Saltpetre Cave white oak chronology developed by dendrochronological analyses (darker line) (from, BLANKENSHIP et al., 2009: Figure 5).



Figure 2: Vats with square-type construction (A and B) overlying an exposed V-shaped vats (C) at Cagle Saltpetre Cave.

mining operations at the site. Thus, the dendrochronological analyses were invaluable for establishing a significant level of chronometric control for the site; this enabled both a better understanding of the historic saltpeter mining and processing activities that took place at Cagle Saltpetre Cave

U.S. States, Territories, and Districts	Saltpeter Production		
	No. of Caves	Pounds Made	Value in U.S. Dollars (1810)
Maine (District)			
Massachusetts		23,600	9,303
New Hampshire			
Vermont			
Rhode Island			
Connecticut			
New York			
New Jersey			
Pennsylvania			
Delaware			
Maryland			
Virginia		59,175	16,244
Ohio			
Kentucky		201,937	33,648
North Carolina			
East Tennessee			2,913
West Tennessee	22	144,895	18,326
South Carolina			
Georgia			
Orleans (Territory)			
Mississippi (Territory)			
Louisiana (Territory)			
Indiana (Territory)			

Illinois (Territory)			
Michigan (Territory)			
Colombia (District)			
Total	22	429,607	80,434

Table 1: Saltpeter production among the U.S. States, Territories, and Districts for the year 1810 (COXE, 1814).

(BLANKENSHIP, 2007; BLANKENSHIP et al., 2009) and helped to situate the site within the larger context of the early industrial development of the Cumberland Plateau region.

3. Discussion and Conclusions

When considered in conjunction with the extant historical data on the domestic saltpeter-mining industry, the dates obtained from the dendrochronological analyses further indicate that Cagle Saltpetre Cave, in addition to other (then) remote caves in the Cumberland Plateau region, were likely mined in response to both local and global politico-economic pressures throughout the nineteenth century. In fact, surveys indicate that in Tennessee alone some 250 caves were mined for saltpeter during this era (PLEMONS, 1995).

In 1803 Britain declared war on France and the ensuing Napoleonic Wars led to disrupted shipping in the Atlantic, which hindered the importation of high quality saltpeter from British India (HICKEY, 1989; O’DELL, 1995). By 1807, Britain was attempting to gain control of all neutral trade with the European continent. France’s response, the Berlin Decree of 1806 and the Milan Decree of 1807, forbade neutral shipping that complied with British trade regulations. In an effort to cease France and Britain’s interferences with U.S. shipping, the United States subsequently passed the 1807 Embargo Act, and later in 1810, Macon’s Bill Number Two. Increasing hostilities led to the United States’ declaration of war against Britain in June of 1812. Data obtained from the 1810 U. S. Arts and Manufactures Census (COXE, 1814), shown in Table 1, indicate that the caves of the Cumberland Plateau region (considered then to be part of “Western Tennessee”) were valuable sources of saltpeter for the U.S. during this turbulent period. Along with Tennessee, the southeastern states of Kentucky and Virginia were the major domestic suppliers of the saltpeter for the year 1810 (contributing a combined total of 406,007 lbs.). The data concerning saltpeter production by Tennessee’s counties for that year (Tables 2 and 3), illustrate that the adjacent White and Warren counties comprised the bulk of the state’s saltpeter

production (contributing a combined total of 129,695 lbs.). Furthermore, saltpeter production (in lbs.) in the Western District of Tennessee was six times greater than that of the Eastern District. In 1810, Cagle Saltpetre Cave would have been included in White County (Van Buren County was formed from portions of White, Warren, and Bledsoe counties in January of 1840). Although it was certainly not the largest supplier of saltpeter in Tennessee, the 1811 vat construction date from Cagle Saltpetre Cave suggests that mining operations may have been instigated at the site, along with other caves in Middle Tennessee, in response to lessening saltpeter supplies both regionally and throughout the country as a whole. These ventures would surely have been profitable, as the 1810 market price for crude saltpeter is said to have increased from 17 cents per pound to \$1.00 per pound during the war (DEPAEPE and HILL, 1981: 90).

Tenn Counties	Saltpeter Caves		
	Number	Pounds	Value in U.S. Dollars (1810)
Bedford			
Davidson			
Dickson			
Franklin			
Giles			
Hickman			
Humphries			
Jackson	3	5,200	864 ¹⁶ / ₁₀₀
Lincoln			
Montgomery			
Maury			
Overton			
Robertson			
Rutherford			
Sumner			
Smith		10,000	1,250
Stewart			
Wilson			
Williamson			
White	19	29,695	3,712
Warren		100,000	12,500
Total	22	144,895	18,326 ¹⁶/₁₀₀

Table 2: Saltpeter production in the Western District of Tennessee for the year 1810 (COXE, 1814).

Tenn Counties	Salt peter Production	Gunpowder Production
	Value in U.S. Dollars (1810)	Value in U.S. Dollars (1810)
Carter		5,400
Sullivan		3,000
Hawkins		
Washington		7,500
Greene	780	200
Cocke		3,000
Jefferson		335
Granger		
Claiborne		
Campbell	2,133	5,300
Anderson		
Knox		
Sevier		
Blount		1,554
Roane		37
Rhea	1,250	100
Bledsoe		
Total	2,913	26,426

Table 3: Saltpeter production in the Eastern District of Tennessee for the year 1810 (COXE, 1814).

A renewed interest in saltpeter mining at Cagle Saltpetre Cave after the Second American War with Great Britain is evidenced by the possible square-type vat construction date of 1854. In general, this period has previously been given incidental mention in regards to the nineteenth century domestic saltpeter industry. However, in Tennessee there is evidence for revitalization of the industry by the mid 1850s. Saltpeter mining apparently recommenced at Big Bone Cave, one of the largest historic saltpeter-mining cave sites in Middle Tennessee (located not far from Cagle Saltpetre Cave), by 1855:

“By a deed dated December 3, 1855, David Williams granted Thomas B. Eastland and Montgomery C. Dibrell use of water and timber adjoining Big Bone Cave for saltpetre manufacturing. In February, 1856, Eastland and Dibrell were incorporated by the legislature, with the name “White County Mining and Saltpetre Mining and Manufacturing Company”...Also in the late 1850’s, additional Van Buren County deeds show that Charles, Charles C., and George Henshaw

of Boston Massachusetts, and William Campbell and M.D.W. Loomis of Cincinnati, Ohio, each briefly held shares in the mining of Bone Cave” [SMITH, 1985: 1].

Englands Cave (also known as Cave Hill Saltpeter Pits), in White County, Tennessee, was also owned by the aforementioned David Williams, who sold the cave and the adjoining property in 1856. Documents indicate that ownership of the cave subsequently changed hands a number of times; in 1859 Walter Mead of New York City sold the cave and property to the Cumberland Saltpeter and Mining Manufacturing Company based in New York City (SMITH, n.d.). Marion O. Smith, a cave historian who has researched the history of the cave states that “...is not known how much saltpeter was obtained from Englands Cave during the 1856-61 period, but undoubtedly there was some production.”

ANDERSON (1967) notes that the Crimean War, fought among the United Kingdom, France, and Imperial Russia, again hindered trade with between the U.S. and European powers. As we have previously suggested, a possible renewed interest in the domestic saltpeter industry may again reflect a disruption in the shipment of refined British saltpeter to the U.S. (BLANKENSHIP et al., 2009: 18).

The onset of the U.S. Civil War also stressed the domestic saltpeter supply, especially in the Confederate States, where Union blockades greatly restricted access to southern ports. In April of 1861, the governor of Tennessee, Isham G. Harris, formed the three-member Military and Financial Board, whose job it was to oversee the state’s preparations for the ensuing war (SMITH, 1997: 98). The Board encouraged the production of saltpeter for the Confederate gunpowder mills by arranging contracts with local businesses or individuals (SMITH, 1997: 102). In doing so, saltpeter agents were instructed to visit potential saltpeter operations throughout the Cumberland Plateau region of Tennessee and Alabama (quoted in SMITH, 1997, 102):

“We wish you to visit salpetre caves near Chattanooga; viz Nicajack, Lookout, & Sauta Caves (the latter in Jackson cty Ala) the Big bone caves in Van Buren Cty worked by Mr Randal & other caves in that & adjoining counties, & the caves being worked through the mountains.

We wish you...to get parties to work all the Caves where sal-petre can be made. To this end we authorize you to make contracts for all the salpetre that can be made in eight & Ten months for 25 cents per pound delivered

on the railroads.

We wish you to observe...& take notes of the quantity being produced at each cave, the number and capacity of the vats, the machinery employed, the number of persons employed, in digging earth...boiling & c, the quantity produced each day & ability, such as respects capacity, energy capital & instructions of each party to increase the production..."

No records exist to date that indicate that Cagle Saltpetre Cave was mined for the Confederate war efforts; however the later construction dates of 1860 and 1861 obtained from Vats 4 and 2 at the site suggest that the cave, in addition to other caves in Van Buren County, may have supplied the Confederacy with saltpeter prior to the Union occupation of middle Tennessee in February of 1862.

Acknowledgments

We are grateful to the Fall Creek Falls State Park staff, for their continued support of this project. We also thank Charles H. Faulkner, Jan F. Simek, Joseph C. Douglas, Sarah C. Sherwood, Nicholas Herrmann, and Marion O. Smith for their continued support and guidance throughout this research. We also wish to thank Meta Pike, Georgina DeWeese, Saskia Van De Gevel, Daniel Lewis, Whitney Kocis, Trudy Rogers, Donnie Anderson, and Mary Jane Kirkham for assisting us in the field and laboratory. Funding support was provided by the Tennessee Historical Commission, the Dogwood City Grotto (Atlanta, Georgia), and the University of Tennessee, Knoxville. Thanks also to David Hubbard for his constructive comments on this paper. Any shortcomings that remain are ours alone.

References

ANDERSON, O. (1967) *A Liberal State at War: English Politics and Economics during the Crimean War*, St. Martin's Press, New York, New York, USA

BLANKENSHIP, S.A. (2007) *Archaeological and Dendrochronological Investigations at Cagle Saltpetre Cave, Van Buren County, Tennessee*, M.A. thesis, The University of Tennessee, Knoxville, Tennessee, USA

BLANKENSHIP, S.A. (2008) Cagle Saltpetre Cave in Van Buren County, Tennessee: The archaeology of nineteenth-century saltpeter caves in the Midsouth, in *Cave Archaeology of the Eastern Woodlands: Essays in Honor of Patty Jo Watson*, D. H. Dye (Ed.), The University of Tennessee Press, Knoxville, Tennessee, USA, pp 219–233.

BLANKENSHIP, S.A., M.G. PIKE, G.G. DEWEESE, S.L. VAN DE GEVEL, H.D. GRISSINO-MAYER (2009) The dendroarchaeology of Cagle Saltpetre Cave: A 19th century saltpeter mining site in Van Buren County, Tennessee, USA. *Tree-Ring Research* 65(1), 11–22.

COXE, T. (1814) *A Statement of the Arts and Manufactures of the United States of America, for the Year 1810*, A. Cornman, Jr., Philadelphia, USA

DEPAEPE, D., C.A. HILL (1981) Historical Geography of United States Saltpeter Caves. *National Speleological Society Bulletin* 43, 88–93.

DOUGLAS, J.C. (2001) *An Environmental History of American Caves, 1660–1900*, Ph.D. dissertation, Department of History, University of Houston, Texas, USA

DUNCAN, M.S. (1995) Kentucky's 1812 saltpeter caves: A case study and literature review, in *Historical Archaeology in Kentucky*, K. A. McBride, W. S. McBride, and D. Pollack (Eds.), Kentucky Heritage Council, Frankfort, Kentucky, USA, pp 51–66.

DUVICK, D.N. (1981) Norris Dam State Park, IGBP PAGES/World Data Center for Paleoclimatology Data Contribution Series # 03613-08405, National Oceanic & Atmospheric Administration /National Geophysical Data Center (NOAA/NGDC) Paleoclimatology Program, Asheville, North Carolina, USA

ELLER, P.G. (1981) Chemical aspects of the conversion of cave nitrates to saltpeter. *National Speleological Society Bulletin* 43, 106–109.

FAUST, B. (1955) Saltpetre mining tools used in caves. *The National Speleological Society Bulletin* 17, 8–18.

FAUST, B. (1964) Saltpetre caves and Virginia history. in *Caves of Virginia*, H.H. Douglas (Ed.), Virginia Cave Survey, Falls Church, Virginia, USA, pp 31–56.

FAUST, B. (1967) *Saltpetre Mining in Mammoth Cave, Ky*, The Filson Club, Louisville, Kentucky, USA, 96 pp.

FENNEMAN, N.M. (1938) *Physiography of the Eastern United States*. McGraw-Hill, New York, New York, USA

- HARDEMAN, W.D. (1966) *Geologic Map of Tennessee*. State of Tennessee, Division of Geology, Nashville, Tennessee, USA
- HICKEY, D.R. (1989) *The War of 1812: A Forgotten Conflict*. University of Illinois Press, Urbana, Illinois, USA
- HILL, C.A. (1981) Mineralogy of cave nitrates. *National Speleological Society Bulletin* 43, 127-132.
- HILL, C.A., and P. FORTI, (1997) *Cave Minerals of the World*. 2nd ed. National Speleological Society, Huntsville, Ala, USA
- HOVEY, H.C. (1897) Our saltpeter caves in times of war. *Scientific American* 76(19), 291.
- LECONTE, J. (1862) *Instructions for the Manufacture of Saltpetre*. Charles P. Pelham, State Printer, Columbia, South Carolina.
- MILLER, R.A. (1994) *The Geologic History of Tennessee*. Reprinted. State of Tennessee, Department of Environment and Conservation, Division of Geology, Nashville. Originally published 1974, Bulletin No. 74, State of Tennessee, Department of Environment and Conservation, Division of Geology, Nashville, Tennessee, USA
- O'DELL, G.A. (1995) Saltpeter Manufacturing and Marketing and Its Relation to the Gunpowder Industry in Kentucky During the Nineteenth Century, in *Historical Archaeology in Kentucky*, K.A. McBride, W.S. McBride, and D. Pollack (Eds.), Kentucky Heritage Council, Frankfort, Kentucky, USA pp 67–105..
- PLEMONS, D.W. (1995) The nitre gardener's guide and home companion: The saltpeter cave survey. *Journal of Spelean History* 29, 3–40.
- POWERS, J. (1981) Confederate niter production. *National Speleological Society Bulletin* 43, 94–97.
- RAINS, G.W. (1862) *Notes on Making Saltpetre from the Earth of the Caves*. Chas. H. Wynne, Printer, Richmond, Virginia.
- SMITH, M.O. 1985. Notes on the early history of Big Bone Cave. *Speleoneews* 23(4), 41–42.
- SMITH, M.O. (1990) *Saltpetre Mining in East Tennessee*. Byron's Graphic Arts, Maryville, Tennessee, USA
- SMITH, M.O. (1997) In quest of a supply of saltpeter and gunpowder in early Civil War Tennessee. *Tennessee Historical Quarterly* 56, 96–111.
- SMITH, M.O. (n.d.) Englands Cave (Cave hill Saltpeter Pits) in the late 1850s, unpublished manuscript in the possession of the author.

HEART OF THE EARTH, HEART OF THE COMMUNITY: THE ROLE OF CAVES IN THE VALIDATION OF SETTLEMENT SPACE

JAMES E. BRADY¹ and ANN M. SCOTT²

¹*Department of Anthropology, California State University-Los Angeles, Los Angeles, Calif*

²*Mesoamerican Archaeology Research Laboratory, The University of Texas at Austin, Austin, Tx*

Although archaeological investigation of caves in the Maya area of Central America has a long history, it is only in the last twenty years that archaeologists have given serious consideration to the role of caves in the validation of settlement space. This theory suggests that caves, because of their cosmological significance in ancient Maya religion, are a primary consideration in the selection of site location. It also holds that sites will be structured around their caves. The historical development of this theory is reviewed and the archaeological evidence supporting this interpretation is offered.

Results of a recent restudy of Quen Santo, Huehuetenango, Guatemala, a site investigated by Eduard Selser at the end of the nineteenth century, is presented. The chasm in which Selser's Caves 2 and 3 are located is shown to be a single ritual complex with many more features and much greater modification than documented by Selser. Selser's excellent work and insightful commentary are blended with recent discoveries to provide an interpretation of the site that underscores the central importance of the caves.

1. Introduction

Although archaeological investigation of caves in the Maya area of Central America has a long history, it is only in the last twenty years that archaeologists have given serious consideration to the role of caves in the validation of settlement space. This theory suggests that caves, because of their cosmological significance in ancient Maya religion, are a primary consideration in the selection of site location. It also holds that sites will be structured around their caves. As we will show, examples of major site architecture being built on top of or in relation to caves has been documented for over a century but the significance of such a relationship has been largely overlooked until recently.

From the beginning, archaeologists have been impressed with the size and beauty of Maya temple pyramids and saw them as analogous to western churches in being the center of community ritual. The great Mayanist, J. Eric THOMPSON (1970:183), however, noted that, in addition to temples, caves and mountain tops were the most important focuses of religious activity. In the first synthesis of Maya cave data, THOMPSON (1959: 124) briefly explored the relationship between caves and temples in noting, "It is difficult to know whether to attach significance to the sixteenth-century use in Yucatan of the term *actun* [cave] to signify both cave and stone building. At first, this appears to support Las Casas' inference that caves and temples were partially interchangeable as scenes for religious rites . . ." After setting up the possibility of a close relationship between caves and temples, Thompson

dismisses the notion by speculating that stone buildings might have fallen into ruin by that time and therefore looked like artificial caves. In a later discussion of caves, THOMPSON (1975: xxii) ends the description of a chamber at Quen Santo by remarking, "It reminds one of temple sanctuaries at Maya sites, particularly Palenque," but the implications are not followed through, and the possibility of a close cave/temple relationship is dropped. With advances in hieroglyphic decipherment it is now clear that pyramids were called *witz*, hills or mountains (STUART, 1987), and that the pyramid temple was essentially an artificial representation of the mountain cave. This relationship runs very deep in Maya thinking so that STUART and HOUSTON (1994: 86) remark that what "is perhaps most striking is that . . . the idiom for referring to human construction is often a metaphor for 'hill.'" Hills and caves are significant in being the embodiment of the most important element of Maya religion, the sacred *Earth*.

The centrality of *Earth* in Mesoamerican religion has important implications for the way in which indigenous people viewed human settlement. It was not the people that were of first importance but rather the landscape that they inhabited. In Central Mexico, the nahuatl term for community, *altepetl*, literally means "water-filled mountain" and refers to the group's sacred mountain (BRODA, 1996: 460). The place glyph for a settlement shows a hill with a second element that identified the particular *altepetl*. In the Maya area, Stuart's (VOGT and STUART, 2005) reading of the "impinged bone" glyph, a common glyph in

Maya inscriptions, as *ch'een* or “cave” led to the discovery that human communities were referred to as *chan ch'een* or “sky-cave” (MARTIN, 2001: 178). Thus, throughout Mesoamerica communities were strongly identified with landmarks in the sacred geography and rituals carried out at these landmarks validated the settlers claim to the land. GARCÍA-ZAMBRANO (1994:218) in his study of rituals associated with the founding of a settlement underscored the importance of cave in stating that, “These cavities, when ritually dedicated to the divinities, became the pulsating heart of the new town, providing the cosmogonic referents that legitimized the settlers’ rights for occupying that space and for the ruler’s authority over that site.”

As noted earlier, examples of caves associated with important architecture have been mentioned for over a century. In his report at the beginning of the 20th century Eduard SELER (1901) noted alignments between the site’s architecture and a series of caves. Although he felt that it was important, he was unable to interpret the reason for the alignment. We will return to this example below. In 1895, while investigating a pyramid on the main plaza at Chichen Itza, Edward Thompson discovered a passageway at the center point of the pyramid that led down to a cave that had been covered over by the construction of the pyramid (THOMPSON, 1938). During the 1920s and 1930s a number of additional examples were reported at Tulum (LOTHROP, 1924:109–110), Cozumel (MASON, 1927: 278; also see SANDERS (1955: 191–192), Pusilha (JOYCE, 1929; JOYCE et al., 1928), Polol (LUNDELL, 1934: 177; also see PATTON, 1987) and Chuncanol (CARTER, 1935: 58). In the 1950s the cave and site at Las Cuevas (DIGBY, 1958, ANDERSON, 1962) was investigated.

These discoveries, however, passed pretty much without notice. In first synthesis, THOMPSON (1959: 128) appears to acknowledge the existence of these alignments in his statement, “Mention should be made of caverns beneath buildings, notably the High Priest’s Grave at Chichen Itza, but discussion of them would vastly extend our subject.” This statement suggests that THOMPSON was aware of enough examples to require an extended discussion but since it appeared near the end of the paper, it would also suggest that he did not consider the association of caves with surface architecture as important as the other issues that formed the core of the article. This is confirmed in Thompson’s second synthesis where the issue is relegated to the category “Other Uses.” THOMPSON (1975: xlii) simply says, “One should also note Maya structures built over caverns, of which the High Priest’s Grave at Chichen Itza is the most important

because of the human bones, worked jades, pearls, and vase of Mexican onyx, all seemingly thrown into the cavern before the aperture was closed.” No interpretation was ever put forward as to the significance of the relationship between cave and architecture.

The plainest case for importance of the cave–architecture relationship was presented in 1970 with the discovery of a cave beneath the Pyramid of the Sun at Teotihuacan in Central Mexico. The mouth of the cave was located beneath the foot of the central stairway and the cave terminated under the center of the pyramid. It appeared that the location, size, and orientation of the second largest pyramid in Mesoamerica had been determined by the cave. René MILLON (1981: 235) immediately appreciated this in noting: “Nevertheless, the stubborn fact remains: the pyramid must be where it is and nowhere else because the cave below it was the most sacred of sacred places.” Although Doris Heyden argued that the cave was a cosmogonic anchor of the community, she did not see this as a general pattern. After learning about the similarity of the placement of the High Priest’s Grave at Chichen Itza to the cave beneath the Pyramid of the Sun, HEYDEN (1981: 14) clearly missed the implication in saying that, “This, of course, presupposes a cave per structure, which is doubtful.”

The theory that caves served to validate settlement space and, therefore, would regularly be incorporated into a site’s major architecture was first explicitly formulated and tested with the Petexbatun Regional Cave Survey in Peten, Guatemala. The systematic recording of caves within the boundaries of the Dos Pilas settlement uncovered far more examples of cave – architecture relationships than previously imagined. Two of the three major architectural complexes had been built in relation to caves and the third might have been. Palaces and range structures were built over moderate sized caves while individual housemounds were found on top of small caves. In addition, the main plaza of a small tertiary center about 12 km from Dos Pilas was laid around a cave (BRADY, 1997; BRADY et al., 1997, DEMAREST et al., 2003). In addition, mounting evidence leaves no doubt that cave – architecture relationships are common and widely distributed (BROWN, 2005; GARCÍA CRUZ, 1991; HALPERIN, 2005; KING and SHAW, 2003; MORALES LÓPEZ, 1987: 77–78; MORALES LÓPEZ and SUMNER-FAUST, 1986: 17–22; PRUFER and KINDON, 2005; PUGH, 2001, 2005; TERRONES GONZÁLEZ, 1990: 90–91).

2. The Quen Santo Restudy

Quen Santo is a large surface site located in a remote, Chuj-

speaking area of the Department of Huehuetenango, in northwestern Guatemala. The site is situated on a plateau surrounded by barrancas. Eduard Seler investigated the site from 1895–1897 and recorded three caves at the base of the western face of the barranca and suggested that many more were undoubtedly present (SELER, 2003:131). Seler's visit occurred just after the caves had been found, looted, and vandalized by the owner of the *finca*, Gustav Kanter. The event had occurred so recently that Seler was able to reconstruct much of the pre-discovery context from testimony of a witness.

California State University, Los Angeles conducted a reconnaissance of the site in 2006 and 2007. The purpose of the visit was to gather sufficient data to allow us to reinterpret Seler's finds in light of advances in Maya studies in the century since his work. We were particularly anxious to restudy the relationship between the caves in the barranca and the architecture on the plateau. GPS readings were taken on the tops of many of the surface structures allowing us to verify that Seler's pace map is, in fact, quite accurate. Exploration along the barranca located a total of six additional caves. All three of Seler's caves were mapped as were a number of the newly discovered caves. The expedition focused its greatest attention on Selers Caves 2 and 3 since these features had been the focus of the earlier study as well.

Ethnoarchaeological investigation allowed us to clear up a confusion created by Seler that was of fundamental importance. Seler appears to have been ambivalent about what the name *Quen Santo* referred to and this caused him to waffle on the translation. As he correctly notes, the "*Quen*" in Chuj means "stone" and "*Santo*" is a Spanish adjective meaning "sacred" or "holy." He concludes in one place that this "refers to the entire plateau and the ruins, and not only the cave" (SELER, 2003:131). But almost immediately he changes his mind and says that it means "cave of stone images" and refers most specifically to Cave 1, which contained several large stone sculptures. In other places, he translates *Quen Santo* as "Sacred Rock," "Cave of the Saints," and "Saints of the Ancients" (SELER, 2003:158, n. 2). Most of these translations seem to center on the caves. While it appears that Seler sensed that the caves were somehow special, he never came to a clear idea of their significance.

Our Chuj informants were very definite that the name means "holy stone" and refers specifically to the large exposed rock formation in which Cave 3 is located. This makes sense in that Cave 3 is the focus of pilgrimage that draws worshippers from Mexico as well as from the Chuj,

Jalkatek, and Kanjobal speaking areas of Guatemala. Although SELER (2003:131) noted that the caves have long been visited by the Maya, no evidence of modern activity at the site was mentioned. The fact that Seler took no note of the caves' singular religious importance to contemporary populations may have contributed to his failure to embrace the fact that the site name referred directly to the caves and to explore the implications of that naming.

Seler also vacillates on the significance of the caves even as he is finding large quantities of stone sculpture. In Cave 1, he discovered two monumental sculptures, a large carved trough, a series of smaller sculptures, and a heavy concentration of incense burners, ceramics and other artifacts. He does not see these items as part of a cave assemblage, however, but rather as valuables from the surface that were hidden in the caves when the site was abandoned. But the caves were not ordinary storehouses for as SELER (2003:135) says, "I was of the opinion that this cave was not selected arbitrarily as a hiding-place, but rather that these caverns were located directly below the temple pyramids and platforms of Pueblo Viejo *Quen Santo* and must have been of importance when the site was occupied." What that importance was, however, we are never told.

As noted earlier that our expedition focused its greatest attention on Selers Caves 2 and 3. The caves are interesting in that they are tectonic rather than solutional. Cave 2 is located at the southern end and Cave 3 at the northern end of a long fissure. It is possible to descend into the fissure near the southern end but moving northward, the ground level drops and the area is enclosed by high, sheer stone walls. The fissure is, therefore, a dramatically bounded natural feature that should be treated as a single large complex. Ethnographic study documents that the fissure operates as a single cultural unit today. Pilgrims climb down into the fissure near the southern end and stop first to make offerings at Cave 2 before continuing on to Cave 3.

A large number of archaeological features suggest that the entire fissure operated as a single complex in the past as well. A well-worn path runs along the eastern fissure wall that is sheltered from rain and has terraces where the ground slopes steeply downward. Finally, the space between the two caves is anything but featureless. Rock art in the form of faces is carved in several places along the wall. A third, fairly large cave that Seler apparently never saw was also found between Caves 2 and 3. The cave descends in several levels and a looted, doorless structure that appears to have been a tomb is found at the lowest level. In addition, there are another two small caves with cultural material in the western

wall of the fissure. Taken together with the modifications surrounding Cave 3, it becomes clear that the fissure is far more of a “built environment” than previously appreciated. We wish to stress this point because Seler’s description tends to suggest that the caves are more separated and the interconnectedness is never discussed.

Of the three caves, Cave 3 is the only one that Seler mapped reflecting the fact that it is clearly the most important feature in the fissure. Allan Cobb’s remapping verifies that Seler’s original map captured the general size and orientation of the cave. At the entrance to the cave, Seler observed two stone sculptures and a flat, stela-like slab of stone 2 m high by 80 cm wide. Some 7 m beyond the entrance, the cave splits into an eastern and a western passage. On the western side, the passage slopes slightly upward and is partially blocked by a wall of dry laid, but well-set, unshaped stones. The wall is 1.5 m high, 3.1 m long, north to south and 1.2 m thick. The wall directs traffic through a meter wide passage along the western cave wall and there is a single step upward even with the beginning of the wall. At the back of the wall a flat slab of limestone 1.51 m high, 72 cm wide and 9 cm thick at the base has been vertically set up like a stela. One of the corners was missing at the time that Seler recorded it and the piece appears to be unremoved from that time. Seler mentions a second slab, 2 m tall that we did not see, but which is shown in his photograph.

The floor beyond the first wall slopes gently upward to a second, more formal, wall. The access way is once again along the western cave wall, in line with the previous passage. The wall is 197 cm high, over a meter thick and runs for 2.5 m north to south. Because the floor slopes upward, the walls are high enough to block vision of anything beyond the wall. The access along the western wall also sets up a dramatic entry into the third chamber. On entering, one is immediately confronted with a stuccoed, masonry structure built into the northeastern corner of the chamber. Unfortunately, the “temple room,” as Seler calls it, had been looted only a few years before but the stucco was still painted a deep red at the end of the 19th century. Using an informant who had been present at the first discovery, Seler provides a reconstruction of the original setting. In the doorway were “ceramic jaguars as large as dogs” (SELER, 2003:151). Behind these were six large, pronged incense burners with elaborately modeled faces. At the rear of the chamber were two stone figures. Seler recovered fragments of one of these and restored it in Berlin. In the center between the sculptures was a perforated stone with a carved face. Plain bowls were also packed in along the floor.

Seler mentions in passing that the floor in the eastern branch of the cave is level. As modern cave archaeologists we immediately picked up on this fact and noted that the same could be said of the first 5 m of the cave entrance and at least 10 m in front of the cave. Along the eastern fissure wall just in front of the cave there is a small chasm 9.5 m long that descends 2 to 3 m to two small caves. The western wall of this chasm is formed by stone retaining walls on either side of a larger breakdown boulder. This offers clear evidence that at least part, but probably all, of the leveled area is an artificial construction.

3. Summary and Conclusions

The glimpse that Seler provides of the caves of Quen Santo is both tantalizing and frustrating. Tantalizing because of the architecture and preservation of an incredibly rich artifact assemblage, but frustrating because Seler could never quite appreciate the importance of what he was seeing. Certainly there were clues. He had a premonition that the entire site was somehow named after the caves; he recognized the relationship between the caves and surface architecture, and he documented the architecture and monumental sculpture. In the end his own preconceptions prevented him from accepting the caves as anything more than storerooms. Seler appears to have shared a widespread Eurocentric view of caves that grew out of the raging battle over evolution. Evolutionists were excavating in caves for fossil evidence of pre-modern humans to support their argument. Caves came to be seen not simply as places of habitation but habitation at low, primitive, or even pre-human level. Thus, it is not surprising that Seler had difficulty in understanding how the caves could play an important role at a highly developed, sophisticated site like Quen Santo.

Simply by applying more recent understandings of ancient Maya cave use, our superficial restudy of the site and caves allows us to advance a very different interpretation. Our discovery of additional caves documented that the relationship between caves and surface architecture noted by Seler occurs consistently and, therefore, must be accepted as deliberate. The fact that surface architecture is consistently and deliberately built over caves argues that the builders were linking the site and the caves. The caves, therefore, must be considered as part of the site complex. Seler’s site map suggests further relationships. At the northern end of the site, a formal masonry stairway leads from the plateau down to the level of the lip of the fissure. There appears to be a wide flat path that leads to the fissure, but excavation will be needed to determine if this is natural or artificial. At the very least, we can say that there is nothing else of note, other than the fissure, in the area of the stairway. Thus, it appears that

the fissure was of such importance that a major architectural feature was constructed to facilitate access to it.

We have argued further that the fissure represents a single ritual complex. This conclusion is based on the recording of many previously unrecognized features, including at least five caves not noted by Selser. The oversight may have had important implications for Selser's interpretation because the largest of the new caves contains an elaborate masonry tomb. The discovery of the tomb is certainly an element of first importance because elaborate masonry tombs are associated with the elite. Given the points made above, we suspect that the fissure served, in the words of GARCÍA-ZAMBRANO (1994:218), as "the pulsating heart" of Quen Santo.

References

- ANDERSON, A.H. (1962) Cave Sites in British Honduras. *Akten des XXXIV Internationale Amerikanisten-Kongresses*, Verlag Ernest Berger, Horn, Vienna, pp 326–331.
- BRODA, J. (1996) Calendarios, Cosmovisión y Observación de la Naturaleza. In *Temas Mesoamericanos*, coordinated by Sonis Lombardo and Enrique Nalda, Instituto Nacional de Antropología e Historia, Mexico, pp 427–469.
- BRADY, J.E. (1997) Settlement Configuration and Cosmology: The Role of Caves at Dos Pilas. *American Anthropologist* 99:602–618.
- BRADY, J.E., A. SCOTT, A. COBB, I. RODAS, J. FOGARTY, and M. Urquizú Sánchez (1997) Glimpses of the Dark Side of the Petexbatun Regional Archaeological Project: The Petexbatun Regional Cave Survey. *Ancient Mesoamerica* 8:353–364.
- BROWN, C.T. (2005) Caves, Karst, and Settlement at Mayapán, Yucatán. In *In the Maw of the Earth Monster: Mesoamerican Ritual Cave Use*, James E. Brady and Keith M. Prufer (Eds.), University of Texas Press, Austin, pp 373–411.
- CARTER, J.B. (1935) A Brief Description of the Ruins of Chucanob. *Maya Research* 2(1):36–59.
- DEMAREST, A., K. MORGAN, C. WOOLEY, and H. ESCOBEDO (2003) The Political Acquisition of Sacred Geography. In *Maya Palaces and Elite Residences: An Interdisciplinary Approach*, Jessica Joyce Christie (Eds.), University of Texas Press, Austin, pp 120–153.
- DIGBY, A. (1958) A New Maya City Discovered in British Honduras at Las Cuevas and an Underground Necropolis Revealed. *The London Illustrated News* 232:274–275.
- GARCÍA CRUZ, F. (1991) Aktunkin: A Maya Cavern in Campeche. *Mexicon* 13(3):45.
- GARCÍA-ZAMBRANO, A.J. (1994) Early Colonial Evidence of Pre-Columbian Rituals of Foundation. In *Seventh Palenque Round Table, 1989*, Merle Greene Robertson and Virginia Field (Eds.), Pre-Columbian Art Research Institute, San Francisco, pp 217–227.
- HALPERIN, C.T. (2005) Social Power and Sacred Space at Actun Nak Beh, Belize. In *Stone Houses and Earth Lords: Maya Religion in the Cave Context*, Keith M. Prufer and James E. Brady (Eds.), University Press of Colorado, Boulder, pp71–90.
- HEYDEN, D. (1981) Caves, Gods, and Myths: World-View and Planning in Teotihuacan. In *Mesoamerican Sites and World-Views*, Elizabeth P. Benson (Ed.), Dumbarton Oaks Research Library and Collection, Washington, D.C., pp 1–39.
- JOYCE, T.A. (1929) Report on the British Museum Expedition to British Honduras, 1929. *Journal of the Royal Anthropological Institute* 59:439–459.
- JOYCE, T.A., T. GANN, E.L. GRUNING, and R.C.E. LONG (1928) Report on the British Museum Expedition to British Honduras, 1928. *Journal of the Royal Anthropological Society* 58:323–349.
- KING, E.M., and L.C. SHAW (2003) A Heterarchical Approach to Site Variability. In *Heterarchy, Political Economy, and the Ancient Maya*, Vernon L. Scarborough, Fred Valdez, Jr., and Nicholas Dunning (Eds.), The University of Arizona Press, Tucson, pp 64–76.
- LOTHROP, S.K. (1924) *Tulum: An Archaeological Study of the East Coast of Yucatan*. Carnegie Institution of Washington, Publication No. 335. Washington, D.C.

- LUNDELL, C.L. (1934) *Ruins of Polol and Other Archaeological Discoveries in the Department of Peten, Guatemala*. Contributions to American Archaeology, No. 8, Carnegie Institution of Washington, Washington, D.C.
- MARTIN, S. (2001) Under a Deadly Star—Warfare Among the Classic Maya. In *Maya: Divine Kings of the Rain Forest*, Nikolai Grube (ed.), Könemann, Cologne, pp 174–185.
- MASON, G. (1927) *Silver Cities of Yucatan*. G. P. Putnam's Sons, New York.
- MILLON, R. (1981) Teotihuacan: City, State, and Civilization. In *Supplement to the Handbook of Middle American Indians, Vol. 1: Archaeology*, Jeremy A. Sabloff (Ed.), University of Texas Press, Austin, pp. 198–243.
- PATTON, J.L. (1987) The Architecture and Sculpture of Polol, El Peten, Guatemala. Master's thesis, San Francisco State University, San Francisco.
- MORALES LÓPEZ, A. (1987) Arqueología de Salvamento en la Nueva Carretera a Calakmul, Municipio de Champoton, Campeche. *Información* 12:75–109.
- PRUFER, K.M. and A. KINDON (2005) Replicating The Sacred Landscape: The *Ce'en* at Muklebal Tzul. In *Stone Houses and Earth Lords: Maya Religion in the Cave Context*, Keith M. Prufer and James E. Brady (Eds.), University Press of Colorado, Boulder, pp 25–46.
- PUGH, T.W. (2001) Flood Reptiles, Serpent Temples, and the Quadripartite Universe: The *Imago Mundi* of Late Postclassic Mayapan. *Ancient Mesoamerica* 12:247–258.
- PUGH, T.W. (2005) Cracks in the Carapace: Underworld Metaphors in Late Postclassic Maya Ceremonial Groups. In *Stone Houses and Earth Lords: Maya Religion in the Cave Context*, Keith M. Prufer and James E. Brady (Eds.), University Press of Colorado, Boulder, pp 47–69.
- SANDERS, W.T. (1955) *An Archaeological Reconnaissance of Northern Quintana Roo*. Carnegie Institution of Washington, Current Report No. 24, Washington, D.C.
- SELER, E. (1901) *Die Alten Ansiedlungen von Chaculá, im Distrikte Nentón des Departments Huehuetenango der Republik Guatemala*. Dietrich Reiner Verlag, Berlin.
- SELER, E. (2003) *The Ancient Settlements of Chaculá in the Nentón District of the Department of Huehuetenango, Republic of Guatemala*. Labyrinthos, Lancaster, Calif.
- STUART, D. (1987) *Ten Phonetic Syllables*. Research Reports on Ancient Maya Writing 14. Center for Maya Research, Washington, D.C.
- STUART, D. and S. HOUSTON (1994) *Classic Maya Place Names*. Studies in Pre-Columbian Art and Archaeology No. 33. Dumbarton Oaks Research Library and Collection, Washington, D.C.
- TERRONES GONZÁLEZ, E. (1990) Proyecto Salvamento Arqueológico Rancho Ina, Quintana Roo. *Mexicon* 12:89–92.
- THOMPSON, E.H. (1897) Cave of Loltun. *Memoirs of the Peabody Museum of American Archaeology and Ethnology, Harvard University*, Cambridge, 1:52–72.
- THOMPSON, E.H. (1938) *The High Priest's Grave, Chichen Itza, Yucatan, Mexico*. Prepared for publication, with notes and introduction by J. Eric Thompson. Field Museum of Natural History, Anthropology Series 27, No.1.
- THOMPSON, J.E. (1959) The Role of Caves in Maya Culture. *Mitteilungen aus dem Museum für Völkerkunde im Hamburg* 25:122–129.
- THOMPSON, J.E. (1970) *Maya History and Religion*. University of Oklahoma Press, Norman.
- THOMPSON, J.E. (1975) Introduction to the Reprint Edition. In *The Hill-Caves of Yucatan*, Henry C. Mercer. University of Oklahoma Press, Norman.
- VOGT, E.Z., and D. STUART (2005) Some Notes on Ritual Caves among the Ancient and Modern Maya. In *In the Maw of the Earth Monster: Mesoamerican Ritual Cave Use*, James E. Brady and Keith Prufer (Eds.), University of Texas Press, Austin, pp 155–185.

NEW RESEARCHES IN A FAMOUS KARST AREA: THE CRADLE OF HUMANKIND (GAUTENG, SOUTH AFRICA)

LAURENT BRUXELLES¹, JOSÉ BRAGA², FRANCIS DURANTHON³, FRANCIS THACKERAY⁴

¹INRAP (National Institute of Preventive Archaeology) - 561 Rue Etienne Lenoir, KM Delta, 30900 Nîmes, France ; UMR 5608 du CNRS - CRPPM/TRACES; laurent.bruxelles@inrap.fr

²Laboratoire d'Anthropobiologie, Université Paul Sabatier, France - 39 Allées Jules Guesde, 31 000 Toulouse, France; braga@cict.fr

³Muséum d'Histoire Naturelle et Laboratoire d'Etude et de Conservation du Patrimoine - 39 Allées Jules Guesde, 31000 Toulouse, France; francis.duranton@cict.fr

⁴Human Origins and Past Environments program (HOPE), Transvaal Museum, PO Box 413, Pretoria 0001, South Africa.

The valley of the Blauawbankspruit River, classified by the UNESCO since 1998, is considered as the cradle of the humankind. It yielded about one third of the remains of earliest hominids (the man's ancestor) known yet for all African continent (about one thousand). These fossils spread on a length of 3 million years (between -4 and -1 million years), the period which includes the appearance of the *Homo* genus (the first men).

Karstic morphologies are very rare in this valley, but the endokarst is highly developed. The Sterkfontein cave system constitutes a real labyrinth with more than 10 km of galleries. The fossils are preserved in breccias initially formed in underground rooms as in Silberberg Grotto (Sterkfontein) for example. But a lot of breccias can also be seen outside and correspond to old caves partially cut by the erosion.

The aim of our research program is to understand the geomorphological evolution of this valley and its cave system in order to describe the paleo-landscapes of the hominids and also to specify the taphonomy of the fossils. During the next missions, we will pursue the geomorphological cartography initiated this year but also the survey of the breccias and the underground fillings. To illustrate this approach, we will start a 3D cartography of the valley of the Blauawbankspruit associated with a detailed map of the caves of the area. The main rooms will be mapped in high resolution with a 3D laser scan.

Résumé : La vallée de la rivière Blauawbankspruit, site classé par l'UNESCO depuis 1998, est considérée comme le berceau de l'humanité. Elle a livré environ un tiers des vestiges d'hominidés anciens (les ancêtres de l'Homme) connus à ce jour pour tout le continent africain, soit un millier environ. Ces vestiges s'évalent sur une durée de 3 millions d'années (entre -4 et -1 million d'années), période clé pour comprendre l'apparition du genre *Homo* dont nous descendons (les premiers Hommes).

Si les morphologies karstiques de surface sont quasiment absentes dans cette vallée, l'endokarst est extrêmement développé. Les fossiles sont préservés dans des brèches formées initialement dans ces cavités et que l'on retrouve soit encore en grotte (Silberberg Grotto, Sterkfontein), soit en surface (Swartkrans, Kromdraai), suite au recoupement de ces remplissages par la surface topographique. L'objectif de notre programme de recherche est de connaître l'histoire géomorphologique de cette vallée afin d'en déduire les paléo-paysages contemporains de la présence des hominidés mais aussi de préciser les modalités de taphonomie des vestiges. Au cours des prochaines campagnes de fouille, nous allons poursuivre la cartographie géomorphologique initiée cette année ainsi que l'étude détaillée des paléokarsts et des remplissages souterrains. Pour documenter cette approche, nous allons lancer une cartographie en 3D de la vallée de la Blauawbankspruit couplée à une topographie détaillée de l'essentiel des cavités du secteur. Les principales salles seront topographiées en haute résolution à l'aide d'un scan laser 3D.

1. Introduction

During three missions, in 2007, 2008, and 2009, we started

the study of a karstic area which is called "the cradle of the humankind," classified by the UNESCO since 1998. It

yielded about one third of the remains of old hominids (the man's ancestor) known for all African continent (about one thousand) but also the only complete skeleton of Australopithecus (Fig.1). These fossils spread on a length of 3 million years (between -4 and -1 million years), the period which includes the appearance of the *Homo* genus (the first men) (Fig. 2). A collaboration between the Witwatersrand University (Johannesburg), the Transvaal Museum (Pretoria), the University Paul Sabatier (Toulouse), the Museum of

Natural History (Toulouse) and the French Institute of Preventive Archeology (INRAP), included in the HOPE program research (Human Origins and Past Environments) was established in order to study this famous area.

The purpose of this paper is to explain the different approaches that we plan to lead for a better understanding of the evolution of this karst and also to precise the paleoenvironments and the taphonomy of the different fossils.

2. Geomorphological Approach

The valley of the Blauawbankspruit is a large valley with a stream flowing toward the northeast (Fig. 3). It is located in the upper part of a large escarpment separating two big natural regions: the Highveld (altitude > 1,500 m) which corresponds to the African Surface and the Bushveld (around 1,000 m), included in the Post-African I Surface (Partridge and Maud, 1987).

Few elements permit to know the story of this landscape and the rhythm of the geomorphological evolution. We know that the African Surface correspond to a peneplain developed after the Cretaceous uplift and that the Post-African I Surface was formed after Early Miocene uplift. According to the surfaces formation, the nick point migration (Partridge and Maud, 1987) and the age of the



Figure 1: Little foot, the only complete skeleton of Australopithecus in the world, was found and is still excavated by Ron Clarke in Silberberg Grotto (Sterkfontein) (L. Bruxelles).

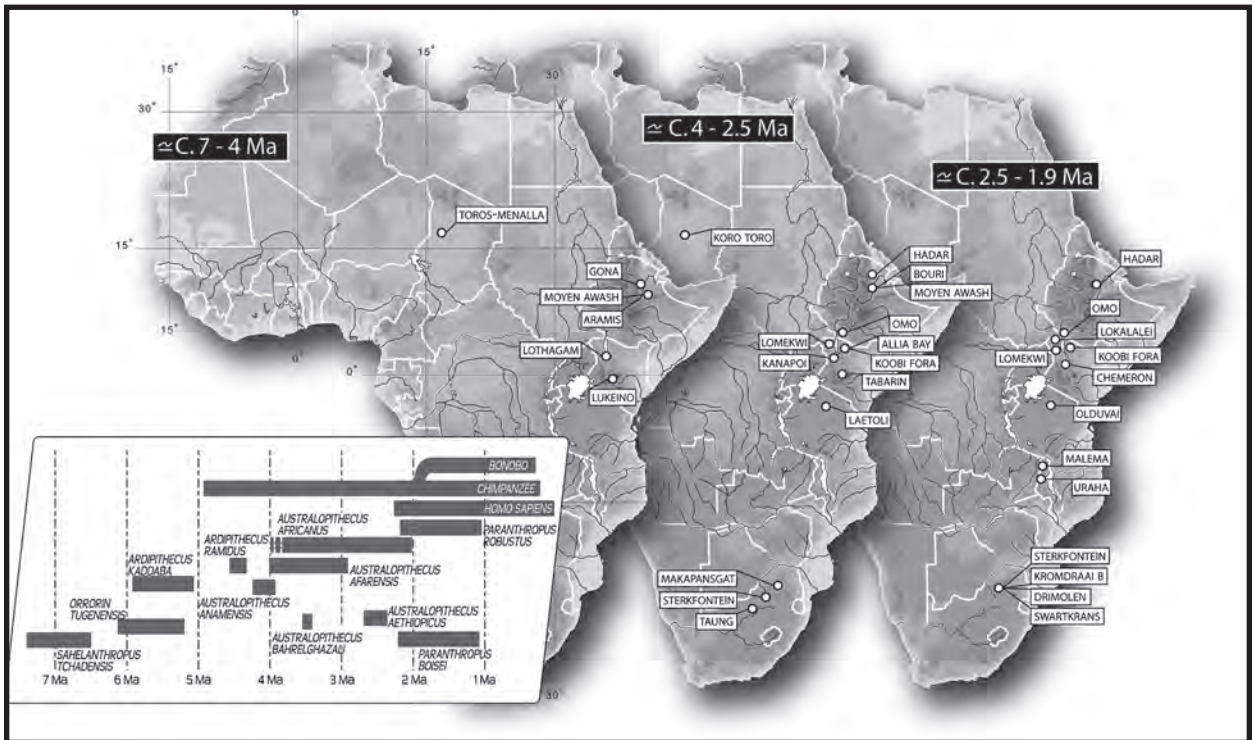

Figure 2: Geographic and chronologic distribution of hominids fossils remains between 7 and 2 millions years (from Crucezy, Braga and Larrouy, 2008).



Figure 3: View of the Blauwbankspuit valley from the NW (hill of Swartkrans) toward the SE, around Sterkfontein (L. Bruxelles).

breccias, the beginning of the speleogenesis might start around the end of the Miocene (Martini et al., 2003).

We started a survey of the morphologies and the superficial formations of the Blauwbankspuit valley. This approach can give us some new keys of the landscape evolution on the basis of the geometric relationships between morphologies and, with the help of the superficial formations, furnish

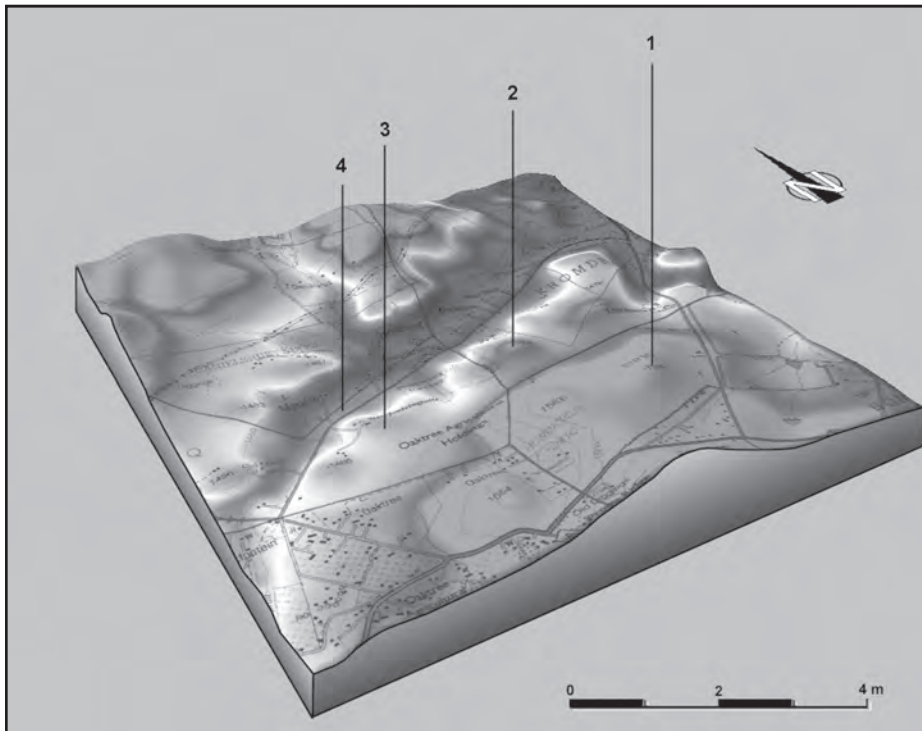

Figure 4: 3D view of the Blauwbankspuit valley around the Sterkfontein area showing the different horizontal surfaces: 1: The highest (around 1580 m of altitude); 2: Between 1,500 and 1,510 m; - 3: Large shelf, well preserved with laterite (1,480 m); 4: Lower shelf, covered with alluvium, a few meter above the river.

some indicators of their past functions. The evolution of the landscape left morphological indicators that we were able to recognize in the valley of Blauwbankspuit. For example, we distinguished several levels of horizontal surfaces in the valley (under the African Surface), on each side of the river (Fig. 4). The structure and the 30° dip to the north of the dolostone and cherts allowed us to exclude any lithologic influence to explain these forms.

The lower levels contain some old alluvium of the Blauwbankspuit. But in the middle of the valley, we found some thick ferruginous crusts that correspond to an old laterite. They provide paleoenvironmental indicators but they also offer the possibility to do paleomagnetism analysis and, perhaps, to obtain a date for their formation. This approach permits us to uncover some new stages of the story of the valley and to precise the hierarchical organization of these forms. It constitutes a first relative pattern into which it will be necessary to insert the development and the evolution of the karstic cavities that trapped the paleontological vestiges.

3. The Study of the Karstic Fillings

Karstic morphologies are very rare in this valley, but the endokarst is highly developed. There are a lot of caves, more or less large, in this part of the Blauwbankspuit River. The Sterkfontein cave system, for example, constitutes a real labyrinth with more than 10 km of galleries. But we have seen numerous other caves, more or less long and partially filled by colluviums, breccias and flowstones. The fossils are preserved in breccias initially formed in underground rooms, as in Silberberg Grotto (Sterkfontein), for example. But a lot of breccias can also be seen outside and correspond to old caves partially cut by the erosion.

These caves are parts of a huge network of galleries truncated by the erosion. During this evolution, detrital sediments, including

dead animals, penetrated from the surface through pits. They formed several big talus and some of the deposits were reworked by underground water streams. Water dripping from the roof of the cave produced flowstones but also consolidated the breccias. But, the lowering of the base level and the erosion of the upper part of the karst provoked the weathering of the top of the breccias (near the surface) and the erosion of the bottom of the deposit, the less calcified. By this way, voids appeared inside the breccias and were sometimes filled by a younger one (Fig. 5). So, karstic fillings are very complicated because we need to distinguish the different generations of breccias, interpenetrated and often in stratigraphic inversion.

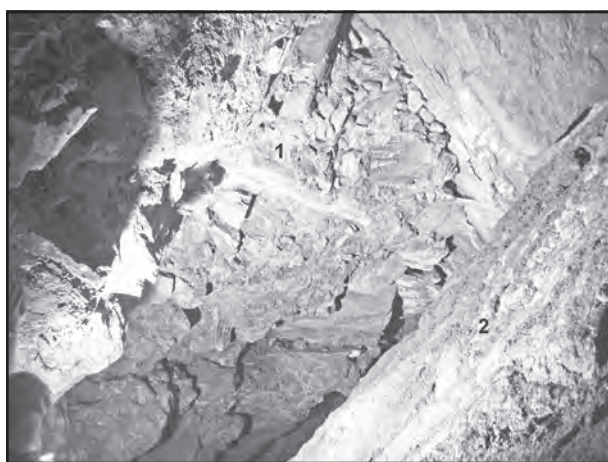

Figure 5: In the Name Chamber (Sterkfontein), the roof is constituted by two old breccias (1). A younger deposit forms a talus and has partially filled the chamber. This example shows how breccias are interpenetrated and often in stratigraphic inversion (L. Bruxelles).

To understand these deposits, we have started to list all the breccias in the caves, but also outside. We recorded the GPS coordinates, we described them and we looked for fossils. Underground, as we have done in Sterkfontein with Kathleen Kuman, Ron Clarke and Dominic Stratford (D. Stratford, L. Bruxelles, and R.J. Clarke, submitted), we want to realize a precise description of the stratigraphy, insisting on the geometry of the deposits, the composition, the presence of bones or stone tools. We also need to understand the geometric, chronologic and genetic relationships between the different fillings. By this way, we try to make correlations between the different generations of breccias and to know if they are reworked or not.

4. Detailed Cartography Project

Each breccias and each detrital talus in the cave has an outside origin. So, if we want to understand their origin

and their evolution, we need to study at the same time the topography of the caves and the morphology of the landscape. As soon as the geomorphological evolution of this valley becomes known, we will be able to understand how, and perhaps when, the galleries were cut by the surface and when the breccias were formed. To go further, we need to reconstruct a precise three-dimensional map of the caves and the outside topography.

So, in addition to the geomorphological cartography initiated this year, we will start a 3D cartography project of the valley of the Blauwbankspuit. The resolution that we need is, at least, one meter, both in location and in altitude precision. It requires the use of fixed laser telemetry or an airborne stereoscopy. All the caves, breccias, flowstones and superficial formations will be included in this map by the way of a GIS.

Concerning the different caves, no topographic datum is available at this time for our 3D map. We plan to make a detailed map of the caves of the area using the classic speleological topographic method for most of them and laser telemetry for some rooms with breccias or fossils. The main rooms will be mapped in high resolution with a 3D laser scan. The 3D cartography that we wish to launch is new, not only in this region of the world, but also in the field of the study of the human evolution. Except its use for fine scientific studies, this cartography 3D can allow us to propose a 3D simulation (topography and vegetation) of this region, and to show its evolution between 3 and 2 million years. A collaboration with South African paleobotanists, French computer scientists and geographers is envisaged for this purpose.

Acknowledgments

We would like to thank Kathleen Kuman (School of Geography, Archaeology and Environmental Studies, University of the Witwatersrand, South Africa), Ron Clarke (School of Anatomical Sciences, Medical School, University of the Witwatersrand, South Africa) and Dominic Stratford (School of Geography, Archaeology and Environmental Studies, University of the Witwatersrand) with whom we are studying Sterkfontein and Lincoln Cave. We also want to thank the French Ministry of Foreign Affairs and Mr. Samuel Elmaleh, Counselor for Science, Culture and Development of the Embassy of France in South Africa for their help and their support.

References

- Crubezy, E. J. Braga, and G. Larrouy, (2008).
Anthropobiologie, 2 Ed. Masson (Abrégés), Paris.

King, L.C. (1962) *The Morphology of the Earth* (Olivier and Boyd, Edinburgh and London).

Martini, J.E.J., P.E. Wipplinger, H.F.G. Moen, and A. Keyser, (2003) Contribution to the speleology of Sterkfontein Cave, Gauteng Province, South Africa. *International Journal of speleology*, **32** (1/4), 2003, pp 43–69.

Partridge, T. and R.R. Maud, (1987) Geomorphic evolution of southern Africa since the Mesozoic. *South African J. Geol.*, **90**, pp 179–208.

Stratford, D.J., L. Bruxelles, and R. Clarke, – Submitted. – New interpretations on the stratigraphy of the fossil and archaeology bearing deposits of the Name Chamber, Sterkfontein. *Journal of Human Evolution*.

THE CONTRIBUTION OF CAVERS TO THE DEVELOPMENT OF MAYA CAVE ARCHAEOLOGY

ALLAN COBB¹, JAMES E. BRADY²

¹4019 Ramsgate Street, San Antonio, TX 78230, USA

²Department of Anthropology, California State University, Los Angeles, Los Angeles, CA 90032, USA

A specialized field of Maya cave archaeology has only developed during the last two decades. As an academic discipline, archaeology has charted the growth and elaboration of cave archaeology through publications whose senior authors are invariably archaeologists. This has tended to obscure the fact that the subfield has benefited tremendously from the direct involvement of cavers who brought specialized skills in mapping, investigating and exploring to an environment that is generally unfamiliar to the archaeologist. Maps done by cavers were more detailed than those by archaeologists, presented more information and quickly convinced archaeologists that cave studies were a far more technical than they had realized. The immediate impact was that archaeologists without training and experience in caves left the work to specialists.

The caver contribution to cave archaeology was far more profound than simply mapping. Ann Scott has proposed that the basic method and theory of cave archaeology were established during what she calls the Foundation Period from 1980 to 1997. Among the most influential projects during that period were the Naj Tunich Project, the Petexbatun Regional Cave Survey, and the Man-Made Caves Project in Guatemala and the Copan Ritual Caves Project and the Talgua Project in Honduras. Cavers often outnumbered archaeologists on these projects and were intimately involved in the day-to-day discussions and decisions about method and theory. For instance it was a caver who pointed out the extensive breakage and movement of speleothems in Maya caves, leading to new insights into cave use. Cavers have also trained archaeologists on several archaeological projects to recognize broken speleothems at surface sites. Without any doubt the methodological, theoretical, and scientific growth of the subdiscipline can be directly attributed to the incorporation of cavers into archaeological projects.

1. Introduction

During the second half of the 20th century, cavers have made substantial contributions to the academic discipline of Maya archaeology. From the 1950s through the 1960s the contribution was limited to a great extent by archaeologists' general neglect of caves and tendency to exclude specialists outside of the narrow limits of their field. Nevertheless, cavers produced valuable data such as Jack GRANT and Bill DAILEY's (n.d.) suggestion that the walls in Loltun were defensive. Although never published, the manuscript was cited by numerous archaeologists. Russell GURNEY (1959, 1962, 1965) produced a number of important studies of caves in Alta Verapaz and even mounted a multi-disciplinary project that included archaeologist Richard Gould (GURNEY et al., 1968).

During the 1970s, the relationship between cavers and archaeologists in Belize changed significantly as C. J. Rushin-Bell and Barbara MacLeod conducted cave exploration with the Belizean Department of Archaeology (DOA). Logan McNatt later joined the DOA as well. For

a more detailed discussion of the contribution of cavers to Belizean archaeology see MCNATT (1996). In addition to collaborating on a number of archaeological investigations, these cavers were instrumental in raising the archaeological community's awareness of caves. Dorie Reents-Budet and MacLeod also mounted their own project in Petroglyph Cave that was noteworthy in having one of the longest field investigations in a cave up to that point. The results have been widely circulated among cave archaeologists in Reents-Budet's master's thesis (REENTS, 1980) and in an unpublished manuscript (REENTS-BUDET and MACLEOD, 1986). A close collaboration between cavers and archaeology appeared to be developing with the presentation of a joint paper by Barbara MacLeod and Dennis Puleston (1979) at the 1978 Palenque Mesa Redonda but Puleston's tragic death two weeks later put an end to that promising start.

In the late 1970s and 1980s, cavers continued to produce important data. Michel Siffre (1979A, 1979B, 1993) explored a number of caves in the southeastern portion of the

Peten and speculated on the significance of archaeological remains. Although his suggestions have not generally been accepted by the field, his reports and technical recording of sites have been valuable and have engendered restudies by the authors of several of his caves (BRADY, 1999; GARZA et al., 2001). Tom Miller (1980, 1981, 1990, 2000) mapped a number of caves with significant archaeological remains and his explorations brought caves to the attention of archaeologists. Although his maps have been used by a number of archaeologists, Miller's impact on archaeology has been relatively small because of his lack of interest in establishing collaborative relations.

Modern cave archaeology grew out of the discovery and later investigation of Naj Tunich (RODAS, 1980). Cavers Ernie Garza and Karen Witte (WITTE and GARZA, 1981) produced the first map of the cave which was used by both *National Geographic Magazine* (STUART, 1981) and the first archaeological investigation (BRADY, 1989). In 1988, art historian Andrea Stone brought caver George Veni to Naj Tunich to map the cave and, in the process, Veni discovered a series of previously unknown passages. The following year, Brady's archaeological exploration of the new passages included Veni and a second caver, Allan Cobb. While the work in the new passage followed general procedures that had been established in previous years, these were modified in consultation with Veni and Cobb. The cavers also modified their mapping procedures to place stations close to artifact concentrations and flagged artifacts as they moved through passages.

In 1990, Veni and Cobb began work on the Petexbatun Project. John Fogarty replaced Veni the following year and

the team of Cobb and Fogarty worked from 1991 through 1993. The sheer size of the Petexbatun Project presented methodological problems because of the complexity in terms of correlating caves with each other and with surface features. All details of the methodology from large to small were worked out in discussions between the archaeologist and two cavers so that it was often difficult assign intellectual credit for the final product to a single individual. Some elements, however, could clearly be credited to cavers. The mapping program used to correlate the data was developed by Fogarty. The cavers were also responsible for suggesting and carrying out the surface survey that tied all of the surface features together.

2. Cavers and Cave Mapping

In his discussion of the development of Maya cave studies at the session of the Society for American Archaeology, Brady (1997) noted that the quality of site maps tends to correlate with the quality of the work carried out. The clearest contribution of cavers to archaeological projects has been in the dramatic improvement in site maps. This reflects the sad reality that most archaeologists simply do not know how to map caves. In his discussion of the history of cave research, Brady (1989) repeatedly noted cave reports that did not contain maps. In another case, the archaeologists' map was misaligned by 90° (BRADY, 1995) (Fig. 1).

Cave archaeologists themselves, however, have not universally embraced the incorporation of cavers and caver techniques of mapping into their projects. Cobb has worked on an array of archaeological projects and has noted tremendous variation in the way that mapping is conducted. On some projects, surface mapping techniques



Figure 1: These two cave maps are of the same cave in Honduras. The map on the left was done by an archeologist while the map on the right was done by a caver. Note the orientation of the cave with reference to the north arrow. The map on the right was reduced so that the scales on both maps are the same. While remapping the cave in 1991, the authors double checked the survey data to confirm the proper orientation of the cave.

are simply transported underground. When Cobb inquired why a passage at a particular cave was not mapped to its termination, he was told that the ceiling was too low to set up a stadia rod. On another project, grids were laboriously set up in areas where artifacts were found. Gridded areas were tied together only if cavers were present to do the mapping. In this case the overall map was an adjunct to gridded areas rather than vice versa.

Our criticism of mapping by archaeologists is not limited simply to the issue of accuracy. Most archaeologists are extremely slow so that a disproportionately large percentage of the project's resources are devoted to mapping. Large surface projects frequently bring surveyors to produce site maps. Naj Tunich has over 3.5 km of passage and the Petexbatun Project had a number of caves over a kilometer in length, including one of over 6 km. Cave archaeologists should recognize the need for specialized help. On the projects where the authors have collaborated, the archaeology always takes longer than the mapping so that time archaeologists spend mapping reduces the time spent on archaeology. Cobb has observed that projects that delegate the mapping to cavers recover far more archaeological data and can say a great deal more about their caves.

3. Cave Exploration

A less frequently mentioned benefit of cavers mapping a site is that exploration occurs at the same time. Cavers are far more familiar with the cave environment than archaeologists and are trained to look for features that might suggest a continuation of a passage. At both Naj Tunich and in the Petexbatun, cavers discovered previously unexplored passages. In the Cueva de Sangre, 90% of the 3.6 km of passage was not known to first archaeologists who explored the cave. In many cases these passages are theoretically important because they have not been picked over by looters (BRADY et al., 1992).

Exploration is not limited to cave environments. Cavers often conducted overland pedestrian surveys looking for additional caves. On Brady's projects, cavers routinely make the first inspection of new caves reported by people in the area. In addition to gathering data on size, morphology, conditions and difficulty cavers are expected to evaluate the archaeological potential as well. Generally the decision to investigate or bypass a cave is based solely on their report. Here it must be mentioned that the cavers in question are experienced enough to recognize a range of ceramic types and know their chronological significance.

4. Theoretical and Methodological Contributions

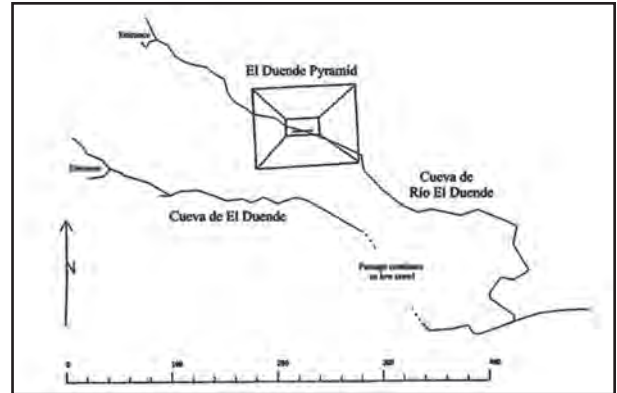

Figure 2: In addition to mapping caves, cavers also perform overland surveys and connect surface features such as the El Duende Pyramid at Petexbatun Project with a cave. As a result of linking the surface and subsurface surveys, it was shown that the cave passed directly under the pyramid.

Ann Scott (2004) has designated the interval between 1980 and 1997 the Foundation Period and characterizes it as the time when the basic theoretical and methodological approaches of cave archaeology were established. She also notes that the period is defined by 40 publications by James Brady so it is within his field projects that one must look for development of these new approaches. A well defined methodological approach can be shown to have crystallized during a relatively short period from 1989 to 1993, that is, during the last two field seasons of the Naj Tunich Project and the entire Petexbatun Project. During these years, Brady always worked with two cavers but only rarely with other archaeologists so that the approach that emerged was a direct result of the interchange between the two sides. As the only caver present for all five season, Cobb can speak some authority on the developments during that time.

Maps produced by the project recorded the presence of geological features, especially cave formations. While such data is routinely recorded by cavers, it was not a feature of most archaeological maps. The maps were a major factor in introducing cavers concern with topography and space into archaeology. Not surprisingly, the Naj Tunich report reflected these issues in sections that discuss differences in the utilization of wet and dry areas as well as large public spaces as opposed to small private ones (BRADY, 1989). In later years both cave maps and archaeological discussion increasingly focused on caves as landscapes and the human modification of them.

The Petexbatun Project, because of its size and complexity, presented an array of methodological problems. Correlating a large number of caves with each other and with surface features simply had not been attempted in archaeology

before this point. All details of the methodology, from large to small, were worked out in discussions between the archaeologist and cavers so that it was often difficult to assign intellectual credit for the final product to a single individual. Some elements, however, could clearly be credited to cavers. The mapping program used to correlate the data was developed by caver John Fogarty. The cavers were also responsible for suggesting and carrying out the surface survey that tied all of the surface features together.

It was also during the Petexbatun Project that Cobb pointed out that a high percentage of speleothems in the caves had been broken. Cobb also attempted the first report on the extent breakage in the Cueva de Sangre but this was not at all systematic. With the recognition that speleothems were being broken it became clear that most of the pieces of formation were being removed from the caves. The cavers trained members of the Dos Pilas Project in the recognition of speleothems and, as a result, several dozen were collected from cultural contexts. These efforts resulted in the first publication calling attention to the widespread breakage of speleothems in the Maya Area (BRADY et al., 1997). As a member of the Xibun Archaeological Research Project (XARP), Cobb pointed out the presence of large quantities of speleothems within the rubble of public architecture. He then gave formal training to XARP archaeologists in the recognition of speleothems and hundreds were documented at various sites (PETERSON et al., 2005). There are now a number of studies, either completed or ongoing, that are using geochemical methods for sourcing speleothems. These give promise of greatly expanding the theoretical implications of a discovery first noted by cavers.

5. Conclusions

Cavers have been an essential element in the development and the professionalization of Maya cave archaeology. As the field took shape in the 1980s, cavers' strength in mapping and exploration complimented corresponding weaknesses in archaeology. This freed archaeologists to concentrate on the interpretation of the cultural remains. At the same time, the presentation of detailed and professionally rendered maps served to set the work of the new discipline off from publications done previously. Finally, the types of maps produced by cavers and the information recorded influenced archaeological thinking and furthered the development of theoretical positions that treated remains in the context of the utilization of a subterranean landscape.

Cavers have also contributed to development of theoretical aspects of the new discipline. The recognition of the widespread breakage, movement and caching of

speleothems must be credited to Cobb. The implications of that observation are only beginning to be tapped but it is already clear the discovery has fundamentally changed archaeological thinking about caves. Cave archaeologists now tend to see their sites as being extensively modified rather than being largely unchanged natural givens. The recovery of huge quantities of speleothems in cultural contexts also has archaeologists recognizing that a reciprocal relationship existed between cave and surface sites. Prior to this tendency was to see a one way flow of cultural material from the surface into caves.

Cavers associated with archaeological projects are well-educated, accomplished individuals possessing a myriad of skills that have contributed to the success of the projects. For instance, among the cavers who have worked with on archaeological projects, Dr. George Veni and Beverly Shade are geologists, Dr. Barbara Luke is an expert in remote sensing, Cobb is a biologist and Fogarty is a computer engineer. The collaboration has worked well because the expertise that cavers bring to the project has been respected and their contributions appreciated. The payoff for archaeology has been clear and dramatic. At the beginning of the Foundation Period in the 1980s, Maya cave studies were seen as being very much on the fringe of accepted archaeology. Over approximately a decade this changed dramatically. The tone and orientation tended to reflect the geological and hard science concerns brought by cavers. By the middle of the 1990s archaeologists began to view cave studies as a highly technical subfield where one did not venture without proper background.

Finally, collaborative relationships take time to develop. In recent years, the authors have come to appreciate that the nearly seamless coordination that is all but taken for granted on their archaeological projects is a direct result of 20 years of development.

References

- BRADY, J.R. (1989) An investigation of Maya ritual cave use with special reference to Naj Tunich, Peten, Guatemala. PhD dissertation, Archaeology Program, University of California, Los Angeles, 478 pp.
- BRADY, J.R. (1995) A reassessment of the chronology and function of Gordon's Cave #3, Copan, Honduras. *Ancient Mesoamerica* 6, 29–38.
- BRADY, J.R. (1997) A history of Mesoamerican cave archaeology. Paper presented at the 62nd Annual Meeting of the Society for American Archaeology,

Nashville, April 2–6.

- BRADY, J.R. (1999) The Gruta de Jobonche: An analysis of speleothem rock art. In *Land of the Turkey and the Deer: Recent Research in Yucatan*, R. Gubler (Ed.), Labyrinthos Press, Lancaster, pp 57–68.
- BRADY, J.R., A. SCOTT, H. NEFF, and M. GLASCOCK (1997) Speleothem breakage, movement, removal and caching: An unreported aspect of ancient Maya cave modification. *Geoarchaeology* **12**, 725–750.
- BRADY, J.R., G. VENI, A. STONE, and A. B. COBB (1992) Explorations in the new branch of Naj Tunich: Implications for interpretations. *Mexicon* **16**, 74–81.
- GARZA, S., J.R. BRADY, and C. CHRISTENSEN (2001) Balam Na Cave 4: Implications for understanding preclassic Cave mortuary practices. *California Anthropologist* **28**, 15–21.
- GRANT, J. and B. DAILEY (1960) The defensive barriers of Loltun. Unpublished manuscript, 12 pp.
- GURNEE, R.H. (1959) Guatemalan underground. *National Speleological Society News* **17**, 133–135.
- GURNEE, R.H. (1962) The Caves of Guatemala. *National Speleological Society Bulletin* **24**, Part 1, 25–30.
- GURNEE, R.H. (1965) Seamay Cave (Caves of the Grand Staircase) Senahu, Alta Verapaz, Guatemala, C.A. *National Speleological Society News* **23**, 114–117.
- GURNEE, R.H., W. RANDOL, A. R. SMITH, R. GOULD, Br. G. NICHOLAS, C. E. MOHR, H. LAND, J. LIMERES (1968) Maya cave discoveries. *Explorers Journal* **46**, 146–186.
- MACLEOD, B. and D.E. PULESTON (1979) Pathways into darkness: The search for the road to Xibalbá. *Tercera Mesa Redonda de Palenque, Vol. 4*, M. G. Robertson and D. C. Jeffers (Eds.), Hearld Peters, Monterey, pp 71–77.
- MCNATT, L. (1996) Cave archaeology of Belize. *Journal of Cave and Karst Studies* **58**, 81–99.
- MILLER, T. (1980) Taulabé, Honduras. *Speleodigest* 40–42.
- MILLER, T. (1981) Houses of stone: Caving in Belize. *Caving International Magazine* **11**, 16–24.
- MILLER, T. (1990) Tunichil Muknal. *National Speleological Society News* **48**, 32–40.
- MILLER, T. (2000) Inside Chiquibul: Exploring Central America's longest cave. *National Geographic* **197**, No.4, 54–71.
- PETERSON, P.A., P.A. MCANANY, and A.B. COBB (2005) De-fanging the earth monster: Speleothem transport to surface sites in the Sibun Valley. In *Stone Houses and Earth Lords: Maya Religion in the Cave Context*, K. M. Prufer and J.R. Brady (Eds.), University Press of Colorado, Boulder, pp 225–247.
- REENTS, D.J. (1980) The prehistoric pottery from Petroglyph Cave, Caves Branch Valley, El Cayo District, Belize, Central America. M.A. thesis, University of Texas, Austin, 189 pp.
- REENTS-BUDET, D., and B. MACLEOD (1986) The archaeology of Petroglyph Cave, Belize. Unpublished manuscript.
- RODAS, H. (1980) Gruta de las inscripciones, con murales Mayas, descubierta en Petén, cerca de Belice. *Prensa Libre*, August 31, Guatemala, pp 2, 30.
- SCOTT, A.M. (2004) The historical context for the founding of Maya cave archaeology. Paper presented at the 69th Annual Meeting of the Society for American Archaeology, Montreal, March 31 - April 4.
- SIFFRE, M. (1979) *L'or des Gouffres: Découvertes dans les Jungles Mayas*. Flammarion, France, 237 pp.
- SIFFRE, M. (1979) *A la Recherche de L'Art des Cavernes du Pays Maya*. Editions Alain Lefevre, Nice, p 239.
- SIFFRE, M. (1993) *Découvertes dans les Grottes Mayas*. Arthaud, France, 187 pp.
- STUART, G.E. (1981) Maya art treasures discovered in cave. *National Geographic* **160**, 220–235.
- WITTE, T.A., and E. GARZA (1981) Naj Tunich: The writing on the wall. *National Speleological Society News* **39**, 149–151.

MORTUARY CAVES AND SINKHOLES IN THE INTERIOR LOW PLATEAUS AND SOUTHERN APPALACHIAN MOUNTAINS OF THE EASTERN UNITED STATES

G. CROTHERS¹, P. WILLEY²

¹William S. Webb Museum of Anthropology, University of Kentucky, Lexington, KY, 40506-0024, USA

²Anthropology Department, Chico State, Chico, CA, 95929-0400, USA

Caves and sinkholes were commonly used for prehistoric mortuary rites and as burial chambers in the Eastern U.S. Woodlands. We identify three regions where such sites are prevalent: Cumberland Plateau in northern Georgia and Alabama, Valley and Ridge province of northeast Tennessee and southwest Virginia, and Highland Rim section of central Kentucky-Tennessee and southern Indiana. We compare the burial pattern among these regions and demographic profiles between cave burial samples and contemporary surface cemeteries. Mortuary cave and sinkhole use was primarily a Woodland Period (1000 B.C. – A.D. 1000) and Late Prehistoric (A.D. 1000-1600) phenomenon, but each region is distinct in the types of karst features used and the burial patterns within them. Cumberland Plateau caves were an important component of Copena burial ritual during the Middle Woodland Period. All age groups and both sexes were buried in Copena cave sites, often elaborately interred similar to burials in Copena mounds on the surface. Valley and Ridge cave burials are primarily in pit caves and date to the Late Prehistoric period. All age groups were deposited in these caves. Males are more common than females in some of the Valley and Ridge pit caves; however, when combined the difference is not statistically significantly different from a contemporary village burial sample. Highland Rim caves show the most diversity in kinds of caves and karst features used for burial purposes. All age groups are found in these caves. When compared to a village burial sample and burial mound sample, only the burial mound sample is significantly different, overwhelmingly composed of adults contrasted with younger age groups. There is a slight tendency for more females to be found in Highland Rim caves, but the sample sizes are too small to draw any firm conclusions.

1. Introduction

Worldwide and cross-culturally one of the most common uses of caves is for mortuary purposes. This use includes both the placement of human remains in remote passages and dropping bodies into sinkholes or vertical shafts. The karst regions of the eastern U.S. are no exception. Caves and sinks are common features throughout much of the Southeast and Midcontinental U.S., and wherever caves are found, at least some were used for mortuary purposes. In this paper, we survey the literature from the eastern U.S. to summarize what is known about cave burial sites and offer a preliminary synthesis on mortuary use of caves through time and across regions.

Little systematic work has been done on burial cave sites in the eastern U.S. Unfortunately, many of these sites have been looted for artifacts or were excavated by amateurs or were excavated early in the history of professional archaeology and inadequate documentation exists. The early discovery of desiccated human remains in a number of dry caves in the southeastern U.S. garnered significant press at the time, but the context of these discoveries are

questionable, and, in at least the case of Mammoth Cave, the two best recorded discoveries appear to be accident victims rather than intentional burials (ROBBINS, 1974). WATSON'S (1974) excavations in the Salts Cave vestibule are a notable exception to the history of poor information. Nearly 2000 broken, cut, burned, and worked human bone fragments were recovered in the vestibule midden deposits. No primary burials were discovered. Salts Cave is a unique funerary situation, which we discuss below.

In the 1980s, we began investigating mortuary caves, especially in Tennessee, and compiling information on historically known burial caves. This renewed interest in burial caves was partly driven by then new state-level cemetery and grave desecration laws, which made us more aware of the destruction of these sites. Cemetery protection laws and the Native Americans Grave Protection and Repatriation Act (NAGPRA) have done a great deal to help preserve remaining mortuary cave sites; however, NAGPRA has also limited what we can learn about these sites through scientific excavations. For the time being, the knowledge we can garner about these prehistoric burial practices must

come from incomplete collections in museum repositories, which are rare, and descriptions of sites and collections in publications or museum archives.

Beginning with our work in the 1980s, it was clear that mortuary cave sites were common, but poorly reported. A recent incident in Kentucky confirmed to us that cave mortuary sites may be even more common than previously realized. In 2005, a small, relatively insignificant cave by Kentucky standards was accidentally opened during construction of a drainage and retention chamber for an industrial park. Subsequent survey of the cave—a mere 1000 ft in length, most of it a low crawl—revealed two places in the cave containing human remains. Both of these locations are associated with small sinkhole depressions on the surface that presumably were open in the past. If not for the keen observation of the cavers who mapped the cave, these remains may have been missed. Today, on the surface these two sinks are unremarkable. Unless this cave is an exceptional chance discovery, there could easily be hundreds if not thousands of similar mortuary sites in the sinkhole plain of the Interior Low Plateaus of Tennessee, Kentucky, and southern Indiana. These underground features are generally not considered to be potential archaeological sites by today's modern cultural resource survey practices.

While mortuary caves appear to be common, they are not the only mode of burial in regions where caves are found. In those regions with significant burial caves, we also commonly find contemporary prehistoric cemetery areas or burial mounds on the surface. A question that has always intrigued us is what determines whether an individual is interred in a cave or interred on the surface? Does association with caves during life determine one's final resting place, or, do the events of death determine one's final resting place? Do cave burials represent aberrant segments of the overall population? Are there patterns by age, sex, or other attributes among cave burial groups? The burial pit caves are a particularly interesting phenomenon because these sites have drops of 30 meters or more, which precluded in-cave mortuary ceremonies. Further, we cannot assume that bodies in pit caves were necessarily deceased before they entered the pit. Could skeletons in deep pit caves represent the execution of enemies or capital punishment of group members?

In this paper, we take a fundamental step by examining age and sex distributions of the individuals represented in burial caves compared to surface burials. Our comparisons are limited to readily available data; however, we consider it a first step to identify patterns, which can be subjected to

more detailed assessment and stimulate re-examination of curated collections. We begin by describing three regions in the eastern U.S. where mortuary caves are common: 1) Middle Woodland burial caves in the middle Tennessee River drainage of northern Alabama and Georgia, 2) Late Prehistoric burial pit caves in the upper Tennessee River drainage of southwest Virginia and northeast Tennessee, and 3) a broad area encompassing the Highland Rim Section of the Interior Low Plateaus from Alabama to Indiana.

2. Middle Woodland Copena Burial Caves

The Middle Woodland Copena Burial Cave Complex (200 B.C. – A.D. 500) was first described by WALTHALL and DEJARNETTE in 1974; their work remains the definitive statement on Copena burial caves. Copena was originally defined as a burial mound complex in the middle Tennessee River Valley of northern Alabama. Similar to the Ohio Hopewell mound complex, Copena is characterized by low, conical mounds containing subfloor burial pits and a set of distinctive burial artifacts, including copper ornaments and celts, galena nodules, steatite elbow pipes, marine shell cups, greenstone hoes and celts, and distinctive triangular projectile points. Unlike the Hopewell complex, however, the Copena burial complex also involved the use of small horizontal caves where extended burials and occasionally cremated human remains were placed in remote passages with distinctive Copena burial artifacts.

WALTHALL and DEJARNETTE (1974) describe six Copena burial caves in northern Alabama. Four of the sites are located in the Tennessee Valley proper and are associated with nearby Copena burial mounds. However, the other two caves (McCalla and Kymulga) are located south of the Tennessee River Valley, somewhat removed from the Copena heartland. WALTHALL and DEJARNETTE suggest that at least the use of Kymulga Cave for Copena burial ritual may have had something to do with nearby Hillabee schist deposits, an important source for making greenstone hoes and celts.

WALTHALL and DEJARNETTE also describe a cave in northwest Georgia (Pine Log Cave) that they consider to be part of a Copena-like burial cave complex. According to KELLY (1964), some 30 to 40 of these caves had been found in the area, but all had been severely looted. In the 1980s, we conducted a limited salvage excavation in Little Beaver Cave, Georgia, to recover exposed human remains (WILLEY, 1991), and a second site, Cureton's Mill Cave, reported by SNEED (1985) may also be a Copena-like burial cave.

Because the skeletal samples from the Copena burial caves were either not recovered or incompletely reported, we can determine little about the age and sex distribution. With a larger sample size we might expect all age groups to be represented, and based on the small sample from Little Beaver Cave, females are well represented (Table 1). However, the Little Beaver sample is extremely small and from a deposit that may contain many additional individuals. Fortunately, this cave is now protected.

Table 1: Age and sex distributions in Kymulga Cave, Alabama, and Little Beaver Cave, Georgia.

Age Group	Kymulga	Little Beaver
Infant (0-2 years)	1	1
Child (3-12)	0	2
Adolescent (13-18)	0	0
Adult (>18)	4	4
Total	5	7
Adult Female	no data	3
Adult Male		1

3. Late Prehistoric Burial Pit Caves

In the extreme southwest portion of Virginia and extending into northeast Tennessee is one of the largest concentrations of cave burial sites in the U.S. (CLARK, 1978). This is the headwater region of the Tennessee River system in the Valley and Ridge province of the southern Appalachian Mountains. The Valley and Ridge is a fold and thrust belt with resistant bedrock forming prominent ridges. Pit caves commonly form in these vertical strata. At least 37 burial caves are known in Virginia alone (BARBER and HUBBARD, 1997). The pit entrances vary in depth from 2.5 m to more than 60 m. Small horizontal burial caves are also known from this region, although they are not as common. Unfortunately, many of the Valley and Ridge caves have been severely looted (HUBBARD and

BARBER, 1997). Only Ausmus Cave, Tennessee (WEBB, 1938; TUCKER, 1989), was excavated professionally. Lake Hole Cave was extensively looted sometime in the late 1980s (WHYTE and KIMBALL, 1997); however, the human remains were recovered as part of an Archaeological Resources Protection Act investigation and an analysis performed before reburial (BOYD and BOYD, 1997). Bull Thistle Cave, Virginia, is largely intact and is now protected. Remains identified in this cave were only those elements exposed on the surface of the talus deposit (WILLEY and CROTHERS, 1986).

The Valley and Ridge caves appear to date primarily to the Late Prehistoric period (ca. A.D. 1000-1600). In addition to bodies dropped into these pits, the deposits also include Late Prehistoric diagnostic artifacts, such as platform pipes, marine shell beads, gorgets, celts, and shell-tempered pottery. Radiocarbon determinations dating to the Late Prehistoric Period were obtained on material from Lake Hole Cave and Higgenbotham Cave. Higgenbotham Cave is associated with the Late Prehistoric palisaded village site of Crab Orchard, which has a comparable burial sample excavated from the village area (MACCORD and BUCHANAN, 1980).

The age distributions of the four largest cave samples show only minor differences (Table 2). Most of the variation is among infants and children. The Lake Hole Cave is the most distinct, with higher proportions of preadolescents compared to adults. Lake Hole Cave and Crab Orchard Village are the two least biased samples in terms of recovery techniques. Lake Hole deposits were sifted through 3 mm mesh screen and complete burials were excavated at Crab Orchard. (Ausmus Cave was trowel sorted, Bull Thistle consists only of material identified on the surface, and we are uncertain how Higgenbotham material was recovered, but only mandibles were used to age the skeletons.)

Table 2. Age and sex distributions for Late Prehistoric cave and village sites.

Age Group	Ausmus Cave, TN		Lake Hole Cave, TN		Bull Thistle Cave, VA		Higgenbotham Cave, VA		Crab Orchard Village, VA	
Infant (0-2 years)	2	8%	23	23%	0	0%	5	5%	20	12%
Child (3-12)	2	8%	23	23%	2	18%	15	15%	30	18%
Adolescent (13-18)	1	4%	4	4%	1	9%	12	12%	10	6%
Adult (>18)	20	80%	49	50%	8	73%	68	68%	107	64%
Total	25	100%	99	100%	11	100%	100	100%	167	100%
Adult Female	4	20%	11	22%	2	25%			49	46%
Adult Male	11	55%	19	39%	2	25%	no data		47	44%
Adult Indeterminate	5	25%	19	39%	4	50%			11	10%

Comparing the Lake Hole Cave to Crab Orchard Village samples, the age distributions are not significantly different (Kolmogorov-Smirnov two-sample test, maximum difference = 0.165, α 0.05 = 0.1725, $p > 0.05$). The same proportion of age groups seem to be interred in both cave and village contexts in the upper Tennessee River valley.

The ratio of males to females in the cave samples shows an approximate 2:1 ratio ($n=32$ males to 17 females; Table 2). By comparison, the Crab Orchard village site had a ratio more closely approximating a normal population 1:1 ratio ($n=47$ males to 49 females; Table 2). Although there appears to be a tendency for males to be more frequently interred in caves, these values are not statistically significant ($\chi^2_{\text{obs.}} = 3.496$, critical value $\chi^2_{0.05, 1} = 3.841$). That is, burial location is independent of sex in the burial samples.

4. Woodland Period Burial Caves in the Interior Low Plateaus

The final region we discuss is not well defined temporally or culturally. This region is the broad Interior Low Plateaus that extend from northern Alabama, through Tennessee and Kentucky, into southern Indiana and Ohio. It also includes caves that are within the Cumberland Plateau escarpment to the east and south. We have identified some 54 burial cave sites from this region, but for most sites we have little information other than vague reports of human remains being found. Where we do have reliable information, however, it suggests that most of the cave deposits are Woodland Period in age (ca. 1000 B.C. – A.D. 1000). Three burial caves with more complete skeletal sample descriptions include Pinson Cave in Alabama (OAKLEY, 1971), Officer Cave in Tennessee (WILLEY et al., 1988), and Salts Cave in Kentucky (ROBBINS, 1974). We use the Libben Site (LOVEJOY et al., 1977) and Robbins Mound (unpublished data courtesy of George MILNER) for comparisons to a village cemetery and burial mound population, respectively. The Libben Site is a Late Woodland ossuary and village, which dates from A.D. 800–1100. Robbins Mound 15Be3 is a large Adena burial mound that contained numerous cremated and elaborately interred burials in log tombs (WEBB and ELLIOTT, 1942) and primarily dates to the Early Woodland Period (ca. 1000–200 B.C.).

OAKLEY (1971) excavated Pinson Cave and described it in his master's thesis. The cave has both a sloping horizontal entrance and a pit entrance. However, it appears that the deposition of human remains occurred as the result of being dropped into the pit. Human remains were scattered throughout the talus deposit with a few articulations. Although human bone dominated the assemblage, other

non-human animal bone was mixed with the material. Artifacts also occurred with the bones, and consisted mainly of flaked and ground stone implements (mostly projectile points), a few bone tools, shell beads, and a few pottery sherds. The artifacts are consistent with the Late Woodland Hamilton Focus (ca. A.D. 500–1000).

Officer Cave is a small, thoroughly looted cave. The entrance has a short drop that can be negotiated by hand. It does not appear to be a typical habitation site and its primary function may have been for mortuary use. The cave also contains petroglyphs, but it is unclear if these are associated with mortuary ceremonies. The deposit also contained Woodland pottery sherds, but looters may have removed other artifacts from the site. A minimum of 15 individuals was present among the human remains recovered from the cave (WILLEY et al., 1988).

As previously mentioned, the Salts Cave vestibule deposits contained extensive human remains, non-human animal remains, ash deposits, and other typical habitation debris (WATSON, 1974). The cave entrance is at the bottom of a large sink and descends steeply into a large vestibule. Little light penetrates the small opening, and inhabiting the vestibule required maintaining a fire. The vestibule deposits appear to be primarily Early Woodland in age (ca. 1000–200 B.C.), but may extend into the Late Archaic (ca. 3000–1000 B.C.). The fragmentary, cut, burned, and polished nature of the human bone led ROBBINS (1974, 158–162) to speculate on the nature of this skeletal sample, suggesting possible ritualistic cannibalism, or disarticulation and crematory processing.

The age distributions of these three cave samples are similar and all age groups are represented (Table 3). A comparison of Pinson and Salts caves with the Libben Site shows no statistically significant differences among age groups. (Officer Cave was excluded from comparison because of the small sample size.) However, there is a significant difference between Libben and Robbins Mound (Kolmogorov-Smirnov two-sample test, maximum difference = 0.381, α 0.01 = 0.1846, $p < 0.01$). Whereas all age groups are well represented in cave sites and the Libben village site, Robbins Mound contains a disproportionate number of adult individuals. It appears that mound burial location was age-related.

Both Pinson and Salts caves have slightly more females than males contrasted with Libben and Robbins, which have a nearly even sex ratio. However, these values are not statistically significantly different. The small sample sizes

from the cave sites, however, do not make these comparisons very robust. It is interesting to note that although Robbins Mound contains predominately adult burials, they are evenly distributed between males and females. Although many of these estimations may be biased by older sex estimation techniques and there is a high proportion of indeterminately sexed individuals at Pinson Cave, the Pinson and Salts skeletal samples have potential for reanalysis and further examination.

5. Conclusions

To summarize, in all three regions, all age groups seem to be well represented, suggesting no age-bias in cave burial. Although, there appears to be some sex bias in cave burials, at least in the burial pit caves in southwest Virginia and northeast Tennessee—adult males seem to have been preferentially placed in pit caves—the difference is not statistically significant. Caves in the Interior Low Plateau may have more adult females than adult males, but larger samples are required to assess this possibility.

In conclusion, the extensive sinkhole plain of the Highland Rim may contain significant numbers of small sinkhole burial sites that would not be routinely identified using standard archaeological survey techniques. Historically, filling sinkholes with sediment, rock, trash, and debris makes it extremely difficult to examine them for archaeological or osteological remains. While we do not advocate intentional excavation of preserved burial cave sites, we are concerned that many of these sites may go unreported and are being inadvertently destroyed by development projects. Few archaeologists have knowledge of karst environments. The lack of surface streams makes sinks, springs, karst windows, and other karst features extremely important in determining prehistoric land use patterns. The burial cave is one of the most important cultural components of karst landscapes. Our hope is that there will be renewed efforts to identify

and protect these overlooked and often desecrated sites.

Acknowledgments

We would like to thank Donna and Cliff Boyd for providing a copy of their report on Lake Hole Cave and interpretations of the data, and George Milner for providing his demographic spreadsheet for Robbins Mound. Patty Jo Watson and Charles Faulkner were instrumental in much of our cave work; we especially thank them for their support over the years.

References

BARBER, M.B., and D.A. HUBBARD JR. (1997) Overview of the human use of caves in Virginia: A 10,500 year history. *Journal of Cave and Karst Studies* 59, 132–136.

BOYD, C.C., and D.C. BOYD (1997) Osteological comparison of prehistoric Native Americans from Southwest Virginia and East Tennessee mortuary caves. *Journal of Cave and Karst Studies* 59, 160–165.

CLARK, W.E. (1978) An assessment of the archeological resources in the caves of Virginia. Sub-committees on Cave Protection Methods and on Cave Management. Virginia Commission on Conservation of Caves, 27 p.

HUBBARD, D.A. JR. and M.B. BARBER (1997) Virginia burial caves: An inventory of a desecrated resource. *Journal of Cave and Karst Studies* 59, 154–159.

KELLY, A.R. (1964) Introduction in *Hopewellian Studies*, J.R. Caldwell and R.L. Hall (Eds.), Illinois State Museum Scientific Studies Vol. 12, pp vi–viii.

Table 3. Age and sex distributions for Woodland Period cave and surface sites.

Age Group	Pinson Cave, AL		Salts Cave, KY		Officer Cave, TN		Libben Site, OH		Robbins Mound, KY	
Infant (0-2 years)	4	9%	8	20%	2	13%	328	25%	1	1%
Child (3-12)	14	30%	6	15%	3	20%	241	19%	6	7%
Adolescent (13-18)	5	11%	4	10%	1	7%	93	7%	4	5%
Adult (>18)	23	50%	23	56%	9	60%	627	49%	72	87%
Total	46	100%	41	101%	15	100%	1289	100%	83	100%
Adult Female	5	22%	8	35%	4	44%	163	26%	20*	27%
Adult Male	3	13%	6	26%	4	44%	153	24%	20	27%
Adult Indeterminate	15	65%	9	39%	1	11%	311	50%	33	45%

* One adolescent estimated to be female by Milner, for a total of 73 individuals.

- LOVEJOY, C.O., R.S. MEINDL, T.R. PRYZBECK, T.S. BARTON, K.G. HEIPLE, and D. KOTTING (1977) Paleodemography of the Libben Site, Ottawa County, Ohio. *Science* **198**, 291–293.
- MACCORD, H.A. SR., and W.T. BUCHANAN Jr. (1980) *The Crab Orchard Site, Tazewell County, Virginia*. Special Publication No. 8, Archaeological Society of Virginia, 156 pp.
- OAKLEY, C.B. Jr. (1971) *An Archaeological Investigation of Pinson Cave (1Je20)*. MA thesis, University of Alabama, 93 pp.
- ROBBINS, L.M. (1974) Prehistoric people of the Mammoth Cave area. Chap. 19 in *Archeology of the Mammoth Cave Area*, P.J. WATSON (Ed.), Academic Press, New York, pp 137–162.
- SNEED, J.M. (1985) Dade County burial cave. *1985 GSS Bulletin* (Georgia Speleological Survey), pp 18–20.
- TUCKER, C.E. (1989) *A Reanalysis of the Osteological and Cultural Remains from Ausmus Burial Cave, Clairborne County, Tennessee (43CE20)*. MA thesis, University of Tennessee, Knoxville, 113 pp.
- WALTHALL, J.A., and D.L. DEJARNETTE (1974) Copena burial caves. *Journal of Alabama Archaeology* **20**, 1–59.
- WATSON, P.J., (1974) Excavations in the vestibule of Salts Cave. Chap. 11 in *Archaeology of the Mammoth Cave Area*, P.J. Watson (Ed.), Academic Press, New York, pp 71–82.
- WEBB, W.S., (1938) *An Archaeological Survey of the Norris Basin in Eastern Tennessee*. Smithsonian Institution, Bureau of American Ethnology Bulletin 118, 398 pp.
- WEBB, W.S., and J.B. ELLIOTT (1942) *The Robbins Mounds, Sites Be3 and Be14, Boone County, Kentucky*. University of Kentucky, Reports in Anthropology and Archaeology **5**, 377–499.
- WHYTE, T.R., and L.R. KIMBALL (1997) Science versus grave desecration: The saga of Lake Hole Cave. *Journal of Cave and Karst Studies* **59**, 143–147.
- WILLEY, P. (1991) Abstract: Excavated human skeletons from Little Beaver Cave. *National Speleological Society Bulletin* **53**, 36–37.
- WILLEY, P., and G. CROTHERS (1986) Archaeological and osteological survey of Bull Thistle Cave (44TZ92), Virginia. Virginia Division of Historic Landmarks, Richmond, 43 pp.
- WILLEY, P., G. CROTHERS, and C.H. FAULKNER (1988) Aboriginal skeletons and petroglyphs in Officer Cave, Tennessee. *Tennessee Anthropologist* **8**, 51–75.

LATE PLEISTOCENE TO HISTORIC VERTEBRATE FAUNAS FROM CAVES AND KARST FEATURES AT CAMP BULLIS, TEXAS

DAVID FROEHLICH¹, LAURA FROEHLICH², RICKARD TOOMEY³, GEORGE VENI⁴

¹Austin Community College, Austin, TX, USA

²Froehlich and Froehlich Consulting, Austin, TX, USA

³Mammoth Cave International Center for Science and Learning, WKU, Bowling Green, KY, USA

⁴George Veni and Associates; currently with National Cave and Karst Research Institute, Carlsbad, NM, USA

Since 1993, multidisciplinary karst investigations have occurred at Camp Bullis, north of San Antonio in Bexar and Comal counties, Texas. Vertebrate remains have been recovered from 62 caves and 11 karst features. The majority were collected as loose bones on cave floors during reconnaissance for endangered species conservation and hydrogeologic research. In a few cases, limited test pits or excavations to further explore the caves and karst features have recovered vertebrate remains, and in two cases, detailed paleontological excavations have been carried out. Vertebrate remains range from introduced species to Pleistocene extinct fauna or extralimital taxa. The majority of the caves preserve demonstrably recent historic or late Holocene faunas, but several caves have significant paleontological potential. These include Flach's Cave (TMM-45555, *Mammuthus* and *Geochelone wilsoni*? present), Root Canal Cave (TMM-43430, fauna includes *Synaptomys cooperi*), B-52 Cave (TMM-43437, *Blarina* and *Microtus* present in one area), and Isocow Cave (TMM-43427, early Holocene to Pleistocene? stratified sample - *Geochelone wilsoni* present). In two cases, the conservation work required the systematic excavation of bone bearing sediments (Flying Buzzworm Cave TMM-43429, and Pain In the Glass Cave TMM-43442). Both of these caves yielded extensive microfauna during wet screening. The Flying Buzzworm fauna was a mixture of two components, a historic component that included historic debris and a Pleistocene? component (with extralimital taxa *Sorex*, *Thomomys*, and *Onychomys*). Pain In The Glass Cave yielded two stratified components, an upper mid-Holocene? fauna stratigraphically superposed over a Pleistocene? fauna (extinct *Mammuthus*, and *Equus*, as well as extralimital *Scalopus*, *Thomomys*, *Cynomys*, and ?*Glaucomyx*). Neither fauna is particularly unique, but were excavated for necessity. While not Camp Bullis' prime paleontological sites, their excavation demonstrate interesting assemblages of taxa and the potential for important vertebrate investigations in this protected and limited-access military reservation. We hope this paper will spur interest and further research at Camp Bullis.

1. Introduction

Camp Bullis is a military training facility in the Fort Sam Houston command located north of San Antonio, Texas in north-central Bexar County and southwestern Comal County. This 113.3 km² facility is situated among dissected limestone hills near the southern edge of the Edwards Plateau. Camp Bullis' primary mission is to provide field training and support for military activities in south Texas. In addition, management of groundwater, natural resources, and endangered species has been an ongoing focus in this rapidly developing area near San Antonio. The Camp Bullis area includes portions of the recharge zones of the regionally important Trinity and Edwards aquifers. As a part of the land management of Camp Bullis, an ongoing karst project (1993 to present) has been undertaken, initially focused on endangered cave species and groundwater monitoring. One additional aspect of these studies has been the collection and identification of vertebrate remains. Collecting and

studying vertebrate bone from caves and karst features is an important component of the geological, biological, and archeological assessments. Potentially, vertebrate remains are an important source of information about past floras, faunas, environments, climates, and the evolution of organisms and caves. Bones found during these studies demonstrate the presence of paleontologically significant caves on Camp Bullis and show the need for continued study of bone material from other caves.

2. Geology

Two units are exposed in the Camp Bullis Area; the Cretaceous (Aptian) Glen Rose and Kainer formations. The Glen Rose Formation was deposited on a shallow carbonate platform and is divided into a lower and upper member. Locally the uppermost 24 m of the total 100 m of section of the lower Glen Rose is exposed and consists of rudistid biohermal limestone, marly limestones, and

the distinctive “Corbula” bed at the top of the section. The upper Glen Rose is locally 137 m thick and consists of resistant limestones and dolomites interbedded with less resistant marls and claystones which weather to the distinctive “stair-step” topography so familiar in the Texas Hill Country. The Kainer Formation, which conformably overlies the Glen Rose is the lowermost formation within the Edwards Group and was deposited in an area of shallow to tidal marine sedimentation in an open marine environment. Only the Basal Nodular, Dolomitic, and Kirschberg members of the Kainer Formation are exposed at Camp Bullis. The Basal Nodular Member is a nodular, massive, fossiliferous, shaly mudstone and grainstone at the base of the Kainer. The Dolomitic Member is a massive, fossiliferous, cherty grainstone. The Kirschberg Member is a highly altered cherty crystalline limestone to chalky mudstone (for a more complete discussion of stratigraphy and lithology see Clark, 2003; Stein and Ozuna, 1995; and Veni et al., 2008 and references therein). Caves are found throughout the section but are concentrated in the Kainer, the top of the upper Glen Rose, and the biostromal limestone within Interval D of the upper Glen Rose. Most caves in the Camp Bullis area likely formed (based on stream incision rates, geochemical denudation rates, and radio-isotope dating of speleothems) in the Middle to Late Pleistocene, probably within the last 300 ka (Veni, 1997; Veni et al., 2008). This gives an upper limit to cave sedimentation and the accumulation of vertebrate remains.

3. Scope of Work

The study of vertebrate remains is not the primary focus of karst work at Camp Bullis. Instead it is an opportunistic line of research that accompanies karst work designed to understand and protect endangered species and karst aquifers. During biological and hydrogeological assessments of caves and karst features, bones are sometimes found. In the course of this project these bones have been collected for identification and analysis. Most collected bones were either exposed and loose on cave floors or recovered during hydrogeologic assessment excavations. Paleontological excavations have only been conducted in two caves at Camp Bullis: Flying Buzzworm Cave and Pain In The Glass Cave.

4. Methods

Identification of the material recovered from Camp Bullis caves was based on comparison to modern skeletal material as well as paleontological remains from other central Texas cave faunas. Modern specimens from both Froehlich and Froehlich Consulting and Texas Memorial Museum – Vertebrate Paleontology Lab (TMM-VPL) were used. Most

of the specimens recovered from Camp Bullis karst features represent taxa that are common in modern, archeological, and paleontological assemblages. For this reason most of the identifications are non-controversial.

In addition to identifying taxa present, a goal of the project has been to determine the potential age of deposits in the caves. This can provide information to assess the potential paleontological significance of karst features and to provide information on ages of fill for use in understanding their hydrogeological history. Preliminary age estimates have been made using several lines of evidence including associated artifacts, biostratigraphy (historic taxa, extinct taxa, and animals with known migration times), sedimentary correlation with dated central Texas cave sites (mainly rough correlations based on sediment and texture: Pleistocene deposits characterized by terra rossa clay Munsell 2.5YR 4/4, Early to Middle Holocene deposits characterized by red to reddish brown silty clay Munsell 5YR 3/3, and Late Holocene to Historic deposits characterized by a black silty clay Munsell 10YR 2/1), and bone condition. Unfortunately, there have been no radiocarbon determinations on any of the Camp Bullis cave faunas due to a lack of sufficient funding.

The paleontological significance of the various deposits is based on the inferred age, the diversity, and the depositional context of the respective faunas. Six caves at Camp Bullis have been identified as containing particularly significant paleontological remains; Isocow Cave (TMM-VPL 43427), B-52 Cave (TMM-VPL 43437), Flach’s Cave (TMM-VPL 45555), Root Canal Cave (TMM-VPL 43430), Flying Buzzworm Cave (TMM-VPL 43429), and Pain In The Glass Cave (TMM-VPL 43442).

5. Significant Caves

Isocow Cave consists of a series of pits and small rooms with a total depth of 42 m. At least three distinct ages of vertebrate material were recovered from the cave. Historic material was recovered from the entrance pit and crawlway, while Late Holocene material was recovered from another pit. Finally, and more importantly, Late Pleistocene material (based on the occurrence of multiple specimens of the extinct tortoise *Geochelone wilsoni*, and a large fossil *Terrapene* in a terra rossa clay, Milstead, 1956, Graham, 1976) was recovered from its 11.9 m deep pit and an associated short passage. The sediments from which these fossils were recovered are consistent with other central Texas Late Pleistocene deposits. No excavations have been done at this cave but further research could produce a significant Late Pleistocene cave fauna.

B-52 Cave is one of the longest (344 m) and the deepest cave (59 m) at Camp Bullis. It contains a Historic or Late Holocene fauna from the Upper Room, while there is an Early to Middle Holocene fauna from the Gordian Room. This older fauna (from a brown clay) has a mixed provenience but importantly preserves small vertebrate remains. Two mammals extralimital to the area today (animals whose modern range does not include Bexar County), *Blarina* (short-tailed shrew) and *Microtus* (vole), have been recovered in this fauna. The presence of these taxa indicates a moister environment than currently occurs in the area (Toomey, 1993, Toomey et al., 1993). It is likely that further collection or excavation will reveal a significant Early to Middle Holocene fauna.

Flachs Cave is a 6 m deep pit connected to a 100 m long intermittently flowing stream passage. Abraded and transported bones were recovered from the lower end of the stream passage. The fauna included at least two individuals of the extinct taxon *Mammuthus* (mammoth, an adult and a possibly fetal individual) as well as a variety of small common taxa (rabbits, rodents, and anurans). The fauna is unusual and significant in preserving a range of different sized individuals, and at least some of the fauna is definitely Pleistocene in age (Graham et al., 1994). This cave fauna also deserves further research.

Root Canal Cave consists of a complex series of pits (39 m total depth) and passageways (151 m total length). Three distinct faunas have been recovered from this cave, a Historic fauna, a Holocene (likely Early to Middle Holocene) fauna, and a Pleistocene fauna. The Early to Middle Holocene fauna is significant because it has abundant small mammals. The Late Pleistocene fauna, although limited, includes *Synaptomys cooperi* (bog lemming), an extralimital taxon that indicates moister conditions and deeper soils than are present today (Toomey, 1993, Toomey et al., 1993).

Flying Buzzworm Cave is a 1 m long passage that leads to a 9 m deep pit. Initial investigation indicated that excavation at the bottom of the cave might lead to further chambers, yet the sediment contained potentially interesting bones. Two areas were excavated in the room at the bottom of the cave: the upper (UX) and lower (LX) excavations. The LX excavations occur in the fall zone in the area that needed to be cleared of sediment for biological and hydrogeological study. In general, the material recovered from the upper and lower excavations consisted of bones from a diverse small animal community.

The taxa identified from both the upper and lower excavations are largely indicative of the modern community of vertebrates found in the area. However, there were a few significant surprises, including extralimital taxa such as *Sorex*, *Thomomys*, and *Onychomys*. The deposit also contained historical debris at numerous levels within the upper excavation. The lower excavation also held significant historical debris, but mostly toward the top of the deposit. The presence of the extralimital taxa in the lower excavation suggests that at least a portion of the fauna consists of older material. The age of the upper excavation's material seems no more than 100-200 years with historical debris throughout, and relatively few examples of taxa that are rare or no longer present in Bexar County (e.g., *Thomomys* and *Onychomys*). This is consistent with other lines of evidence such as the dark brown color of the clay-rich sediment. The deposit is not younger than about early to middle 20th century because it lacks the modern immigrant armadillo or the introduced *Mus* or *Rattus* (Graham et al., 1994). The age of the lower excavation materials is much more problematic. The historical debris is consistent with the dark color of the uppermost sediment. However, there are significant faunal differences that would suggest a much greater age for a portion of the material. The most surprising element of the fauna is a mandible with teeth and an upper incisor that is confidently identified as *Sorex*, probably *S. cinereus*. *Sorex* is only known from Late Pleistocene deposits in Texas (Graham et al., 1994) and thus indicates a significant age for some of this deposit. Note also that the occurrence of *Sorex* is coincident with the occurrence of *Thomomys* among the geomyid remains. It seems likely then that the lower excavation consists of at least two components, a younger historic component, potentially derived from the redeposition of material from the upper excavation, which overlies and is at least partially mixed with an older Pleistocene component that documents significantly different climatic conditions.

Pain In The Glass Cave is a 10-meter-deep pit that leads through a 4-meter-long passage to a 14-meter-deep pit. Bones were initially recovered during the excavation of trash from the entrance pit (thus the name). These initial bones included several enamel plates from the tooth of a mammoth (*Mammuthus* sp.) and six pieces of a bison (*Bison* sp.). After the initial investigations, sediments slumped and blocked access to the lower pit. During this period, more mammoth tooth plates were recovered, again demonstrating Pleistocene material in the fill. Bone was also recovered from a hanging remnant of orange-brown silts on the side of the entrance pit. The bone suggested that older, intact, bone-bearing deposits were present in the cave. The presence

of bone from the orange-brown fill combined with the presence of definitely Pleistocene material, suggested that Pain in the Glass Cave might have important Pleistocene, bone-bearing deposits. Their position on the side of the entrance required removal or stabilization before further endangered species and hydrogeological monitoring could proceed deeper in the cave.

The hanging remnant, an approximately 1.5 m thick sediment sequence, resided in an alcove about 2.5 m below the top of the entrance pit and on its east side. This sediment was systematically excavated in 5-cm-deep levels, although as the number and size of rocks increased toward the bottom of the unit, vertical control became increasingly difficult and some levels consisted of 10 and even 15-cm intervals. Several voids in the fill were noticed during the excavations. In one case, a relatively large void discovered along the margin of excavation extended from level 17 into 18 and contained loose material including some bone. Paleontological excavation ended when a sufficient section of the deposit was removed to allow safe access into the cave. While additional bone-bearing sediment remained, it was left undisturbed to preserve it should more paleontological excavation be warranted in the future. A concrete retaining wall was built in the entrance pit to protect the unexcavated portion of the deposit

The deposit consisted of clay-rich friable sediment that was initially dark gray (5Y 3/1) but became gradually redder as depth increased and organic content decreased. By level 10 (45-50 cm), the fill was dark reddish brown (5YR 3/4). The change in coloration with depth was gradual with no stratigraphic discontinuities noticed to indicate any subdivision. No articulated bone was noted in the deposit, although several units did have similar material from a single taxon suggesting the potential association of several elements.

The fossil material recovered from Pain in the Glass Cave is diverse and represents an excellent microfauna from a central Texas cave. Material from amphibians, reptiles, birds, and mammals were identified. The bird material is interesting and somewhat unusual. Because of the relative fragility of bird bones, they are not commonly recovered. The current relatively low diversity in the identified birds is a consequence of identification intensity rather than lack of material; as work progresses, the identified bird fauna should expand.

Two general preservation modes were noted: material that showed evidence of exposure, and more or less pristine

bones with little or no evidence of surface weathering. These modes probably represent material that was exposed on the surface in the catchment area and material that was deposited directly in the cave, either because the cave acted as a natural trap for some organisms or because the bones were carried in as prey by resident carnivores and omnivores. Some of the material, especially some of the small mammal remains, shows evidence of consumption and or digestion (e.g., eroded enamel on teeth, characteristic breakage patterns etc.) that presumably represent the activities of bird or mammal carnivores and omnivores.

There are a number of taxa found in this deposit that are interesting for various reasons. The most surprising taxon may be the southern flying squirrel (*Glaucomys volans*), a rare component of the central Texas fauna typically found in the more wooded environments of east Texas (Kutac and Caran, 1994). The identification of *Glaucomys* from a central Texas cave would be significant since it has not yet been definitively documented in the fossil record in the area (Graham et al., 1994), although Bexar County is on the extreme western edge of the current range. The presence of *Scalopus* (the eastern mole), geomyids (pocket gophers, *Geomys* and *Thomomys*), and *Cynomys* (prairie dog) document the presence of deep soils within the area of the cave. *Scalopus* requires well-drained soils but avoids extremely dry soils. Eastern moles are relatively rare in the local area but are present in specific habitats. The presence of *Scalopus* in levels 20 and 21 suggests deeper, moister soils than present in the area today. Likewise, pocket gophers (*Geomys* and *Thomomys*) need approximately 1 m of soil in which to burrow. Only *Geomys* is currently known from Bexar County, although largely from areas east of the Balcones Escarpment (Kutac and Caran, 1994). *Geomys* is found virtually throughout the deposit (only missing in levels 18, 21, 22, and 24). It is possible that the absence of this taxon in the lowest levels may indicate some environmental shift during that period of time. It is about coincident with the presence of *Scalopus* and *Blarina* (the short-tailed shrew). However, it is unclear at this point if there is any significance to the absence of *Geomys*. Specimens of *Thomomys* have been identified from levels 10 and 13. *Thomomys* typically is found in drier, sandier soil than *Geomys*. Like the geomyids, *Cynomys*, which was recovered from level 18, requires deep soils to burrow, generally 1-2 m (Nowak, 1999). Prairie dogs are known historically from Bexar County but were extirpated about 1800 (Kutac and Caran, 1994).

Another taxon recovered from Pain In The Glass Cave with important temporal significance is *Equus* (horse).

Horses were present in North America until the end of the terminal glacial cycle and then absent until reintroduction by Europeans (Graham et al., 1994). Consequently, the recovery of *Equus* teeth indicate a Pleistocene age (>10,000 BP) or an age within the last 400 years. A Pleistocene age for the deposit would accord well with the original discovery of *Mammuthus* tooth plates during the initial 1994 excavation of the trash that had been deposited within the cave.

The age of the fill in Pain In The Glass Cave is difficult to assign. Conflicting evidence points to a historic age, a Late Pleistocene or early Holocene age, or potentially a unit of mixed material. There is a historic component to the deposit as demonstrated by the presence of historic trash that filled the entrance pit as well as small amounts of glass and ceramics in the excavated deposit itself. However, the absence of armadillo (*Dasyus novemcinctus*) suggests an age older than the majority of the trash. Armadillo entered the area around 1900 (Humphrey, 1974, Davis and Schmidly, 1994). Its absence in the deposit is not necessarily indicative of the absence of armadillo when the deposit was formed, however, armadillo shells are composed of many small bone scutes, that are very likely to be incorporated into a deposit if armadillos are present. The presence of *Blarina* (the short tailed shrew) in levels 19-22 strongly suggests that portions of the deposit may be of considerable antiquity. *Blarina* was extirpated from the area in the mid-Holocene based on dated faunas in the area (see Graham et al., 1994), thus the presence of *Equus* in levels 1, 15, and 18 suggest either a Pleistocene or historic age for the deposit. It is possible that the horse tooth fragment recovered in level 1 may represent historic horse (although its preservation suggests that it is not modern), however the horse remains from levels 15 and 18 are much more problematic. The presence of fragmentary human remains in levels 11, 12, 14, and 16, overlapping in distribution with the *Equus* remains might suggest a much younger age (within the last 400 years) than indicated by the presence of *Blarina*. Alternatively, the presence of *Equus* with *Homo* might indicate a much older age (Late Pleistocene). Without other data, such as a radiocarbon date on the bone, there is no definitive way to distinguish between these possibilities. Much of the large material, including the horse teeth, are mineralized which may imply great age; however, this is a subjective assessment and can be incorrect. Finally, the presence of prairie dog (*Cynomys*) in level 18, eastern mole (*Scalopus*) in levels 20 and 21, and pocket gophers (*Geomys* and *Thomomys*) throughout the deposit would indicate a depth of soil not currently present on much of the Hill Country uplands, but their presence is not necessarily indicative of the area around the cave so much as the presence of deep soils within the range of carnivores or raptors using the cave (Toomey

et al., 1993). Given the uncertainties with the information provided by the fauna, establishing a definitive age for the deposit is currently impossible. However, it seems most likely much of the deposit dates to the Late Pleistocene or Early Holocene, possibly with the inclusion or mixture of more recent materials. Ongoing analysis of the remaining excavated material may answer some of these questions, as well as radiocarbon dating charcoal or bone derived from the deposit.

6. Conclusions

The caves and karst features of Camp Bullis preserve a diverse and important vertebrate record. Although the majority of cave and karst research has focused on areas other than the collection of vertebrate remains, numerous caves and karst features (62 and 11 respectively) have yielded fossil vertebrates. Some of these cave deposits at Camp Bullis have the potential to preserve important and unique faunal data for the study and reconstruction of the animals and climate of central Texas since the Late Pleistocene.

Acknowledgments

We thank all of the people who participated in this project, of particular note: from Camp Bullis, Jackie Schlatter, Chief of Natural and Cultural Resources, and Lucas Cooksey; our field team: Chris Murray, Chris Thibodaux, Dave Dufeu, and Ron Ralph; and material processing by Dave Dufeu and Michael Osborne.

References

- Clark, A.K. (2003) Geologic framework and hydrogeologic features of the Glen Rose Limestone, Camp Bullis Training Site, Bexar County, Texas. U.S. Geological Survey, Water-Resources Investigations Report 03-4081, 9 p. + 1 pl.
- Davis, W.B., and D.J. Schmidly (1994) *The mammals of Texas*. Texas Parks and Wildlife Department, Austin, 338 pp.
- Graham, R.W. (1976) *Pleistocene and Holocene mammals, taphonomy, and paleoecology of the Friesenbahn Cave Local Fauna, Bexar County, Texas*. Ph.D. dissertation, The University of Texas at Austin, 233 pp.
- Graham, R.W., E.L. Lundelius Jr, and FAUNMAP Working Group (1994) FAUNMAP: A database documenting Late Quaternary distributions of mammal species in the United States. *Illinois State Museum Scientific Papers*, 25 (1-2).

- Humphrey, S.R. (1974) Zoogeography of the nine-banded armadillo (*Dasybus novemcinctus*) in the United States. *Bioscience*, **24**, 457–462.
- Kutac, E.A. and S.C. Caran (1994) *Birds and other wildlife of south central Texas*. University of Texas Press, Austin.
- Milstead, W.W. (1956) Fossil turtles of Friesenhahn Cave, Texas, with the description of a new species of *Testudo*. *Copeia*, **1956**, 162–171.
- Nowak, R.M. (1999) *Walker's Mammals of the World, 6th edition*. Johns Hopkins University Press, Baltimore.
- Stein, W.G., and G.B. Ozuna (1995) Geologic framework and hydrogeologic characteristics of the Edwards Aquifer recharge zone, Bexar County, Texas. U.S. Geological Survey Water-Resources Investigations 95-4030, 8 pp + 1 pl.
- Toomey, III, R.S. (1993) *Late Pleistocene and Holocene faunal and environmental changes at Hall's Cave, Kerr County, Texas*. Ph.D. dissertation, The University of Texas at Austin, 561 pp.
- Toomey, III, R.S., M.D. Blum, and S. Valastro, Jr. (1993) Late Quaternary climates and environments of the Edwards Plateau, Texas. *Global and Planetary Change*, **7**, 299–320.
- Veni, G. (1997) *Geomorphology, hydrogeology, geochemistry, and evolution of the karstic Lower Glen Rose Aquifer, south-central Texas*. PhD dissertation, Pennsylvania State University, published as Texas Speleological Survey Monographs, 1, Austin, Texas, 409 pp.
- Zara Environmental and George Veni and Associates (2008) Hydrogeological, biological, archeological, and paleontological karst investigations, Camp Bullis, Texas, 1993-2008. Report for Natural and Cultural Resources, Environmental Division, Fort Sam Houston, Texas, San Antonio, Texas, 2736 pp.

FOSSIL MAMMALS FROM ISLAND FORD CAVE, VIRGINIA, USA

FREDERICK GRADY¹, DAVID A. HUBBARD JR²

¹Department of Paleobiology, Mail Stop 121, National Museum of Natural History, Washington, DC 20560

²retired, Virginia Department of Mines, Minerals and Energy's Division of Geology and Mineral Resources, DavidHubbard.AP@gmail.com

Fossil mammal remains have been found in three different localities in Island Ford Cave, Alleghany County, Virginia. In the first locality a nearly complete skeleton of a short-faced bear, *Arctodus simus* was recovered. This find has been discussed elsewhere. Two additional localities have been found closer to the entrance and consist mostly of small species of vertebrates. Both have similar lists of mammal taxa, but significantly different radiocarbon dates. Locality 2 consisted of a small pocket dominated by fish bone from which about 40 kilograms of matrix was collected and washed through fine mesh screens. Locality 3 was closer to the entrance and considerably larger and stratified. About 400 kilograms from this site was collected and similarly processed. Over 30 species of mammals were found at each site, most of them the same. One extinct species was found at each site, *Mammuthus* sp. from site 2 and *Canis dirus* from site 3. Extirpated species found at both sites were *Spermophilus tridecemlineatus*, *Phenacomys* sp., and *Microtus* cf. *M. ochrogaster*. *Microtus xanthognathus* was found only at site 2. Two radiocarbon dates were obtained from bone fragments at site 2: 33,000 +/- 1700 and 39,300 +/- 1100. A single date of 11,986 +/- 76 was obtained from site 3. Though differing in age by more than 20,000 years, these sites appear to show faunal stability.

1. Introduction

Island Ford Cave in Alleghany County, Virginia, was first brought to the attention of one of us (FG) by cavers who discovered several high school students with large bones they had collected in the cave. These were identified as a large bear. After a proper Virginia cave collection permit was obtained, a series of excavation trips were undertaken and the major part of a skeleton of a giant short-faced bear (*Arctodus simus*) was collected along with a small amount of associated fauna. GRADY (1997) gave a preliminary account of this work and this material is now being described by Blaine Schubert and FG. As the work on the bear site was finishing, a second site was located by DAH, which is designated Island Ford 2 (IF2). This was a small pocket of bone rich sediment of about 40 kg. It was bagged and wet screened outside the cave in fine mesh (0.7 mm openings) net bags and contained mostly small vertebrates. After this discovery DAH found a third locality IF3, which was more extensive both vertically and horizontally than IF2. This material was bagged with both horizontal and vertical coordinates. The vertical thickness varied from 1-45 cm depending on the stratigraphy, which was complex

in places because it was deposited over a substrate of breakdown. Approximately 400 kg of bone bearing matrix was collected from IF3. The matrix was screened in the same manner as IF2. The screened concentrates were separated into several size fractions to ease sorting. The finest fraction was sorted using magnification. All fossil specimens collected from the three sites are deposited in The National Museum of Natural History, Smithsonian Institution (USNM).

Two AMS radiocarbon dates were obtained on large unidentified mammal limb fragments from IF2: 33,000 +/- 1700 (AA42514) and 39,300 +/- 1100 (AA45375), while a single bone fragment from IF3 dated 11,986 +/- 76 (AA45376). Detailed locality data for the cave and the sites within is available from the authors for qualified researchers.

Island Ford Cave is a high visibility cave frequently visited by recreational cavers. The entrance is 4.5 to 6 m high by three meters wide and is developed in the western flank of an anticline. The cave extends some 168 m along the strike of the fold structure and contains some 425 m of passage

Species	common name	minimum number of individuals	
		IF2	IF3
<i>Sorex cinereus</i>	masked shrew	6	1
<i>Sorex hoyi</i>	pygmy shrew		1

<i>Sorex fumeus</i>	smokey shrew	2	
<i>Sorex</i> sp.	long-tailed shrew		1
<i>Blarina</i> cf. <i>brevicauda</i>	short-tailed shrew	9	14
<i>Parascalops breweri</i>	hairy-tailed mole	1	2
cf. <i>Condylura cristata</i>	star-nose mole		1
<i>Eptesicus fuscus</i>	big brown bat	36	26
<i>Myotis</i> spp.	small brown bats	74	78
<i>Perimyotis subflavus</i>	tri-colored bat	2	11
<i>Corynorhynchus</i> sp.	big eared bat	12	9
<i>Leporidae</i>	rabbit or hare	2	2
<i>Marmota monax</i>	woodchuck		1
<i>Tamias striatus</i>	eastern chipmunk	1	3
<i>Spermophilus tridecemlineatus</i>	thirteen-lined ground squirrel	1	1
<i>Glaucomys</i> cf. <i>volans</i>	southern flying squirrel	3	2
<i>Tamiasciurus hudsonicus</i>	red squirrel	2	
<i>Castor canadensis</i>	beaver	1	1
<i>Neotoma magister</i>	Allegheny woodrat	10	10
<i>Peromyscus</i> sp.	deer or white footed mouse	7	6
<i>Clethrionomys gapperi</i>	red-backed vole	14	11
<i>Phenacomys intermedius</i>	heather vole	2	1
<i>Microtus pennsylvanicus</i>	meadow vole	10	13
<i>Microtus chrotorrhinus</i>	rock vole	3	
<i>Microtus</i> cf. <i>xanthognathus</i>	yellow-cheeked vole	3	
<i>Microtus</i> sp.	vole	2	5
<i>Microtus pinetorum</i>	pine vole	6	5
<i>Microtus</i> cf. <i>ochrogaster</i>	prairie vole	5	7
<i>Synaptomys cooperi</i>	southern bog lemming	3	4
<i>Ondatra zibethicus</i>	muskrat	2	
<i>Zapus hudsonius</i>	meadow jumping mouse	2	
<i>Napaeozapus insignis</i>	woodland jumping mouse	5	1
<i>Erethizon dorsatum</i>	porcupine	1	
<i>Canis dirus</i>	dire wolf		1
<i>Mustela nivalis</i>	least weasel	1	
<i>Mustela frenata</i>	long-tailed weasel	1	1
<i>Mustela</i> cf. <i>vison</i>	mink		1
<i>Lontra canadensis</i>	river otter	1	
<i>Procyon lotor</i>	raccoon	1	
<i>Lynx</i> cf. <i>rufus</i>	bobcat	1	
<i>Cervus elaphus</i>	elk	1	
<i>Odocoileus virginianus</i>	white-tailed deer		1
<i>Mammuthus</i> sp.	mammoth	1	

Table 1: A list of species and the minimum number of individuals collected from the Island Ford Cave bone deposits IF2 and IF3.

developed in upper and lower level passages. A stream occupies the lower level passage, entering the rear of the cave as a siphon and traversing to within about 45 m of the entrance. These waters reappear in the Jackson River across the road from the entrance (HOLSINGER, 1975).

2. Discussion

All classes of vertebrates were found in both localities, although only the mammals have been identified (Table 1). There are large numbers of small fish bones in the material from both IF2 and IF3. A few of the fish vertebrae from IF3 are greater than 1 cm diameter, indicating a fairly large fish. Amphibians, small reptiles excluding turtles, and birds are present in modest numbers. Mammals are second to fish in abundance.

The vast majority of mammals from both IF2 and IF3 are small species. One large extinct species is represented from each site. From IF2, a single unworn tooth plate of a juvenile mammoth (*Mammuthus* sp.) was recovered. There was no cement on this tooth fragment and it probably represents an unerupted tooth. This is only the second record of mammoth from a Virginia cave. The other being an adult molar from Endless Caverns, Rockingham County (HUBBARD and GRADY, 1999). A single second lower molar (m2) of a dire wolf (*Canis dirus*) was found in IF3. The only other record of a dire wolf from Virginia was a cuboid from Clarks Cave, Highland County identified as *Canis cf. dirus* (GUILDAY et al., 1977; NOWAK, 1979).

Several species of small mammals from these two sites are believed to have disappeared from Virginia at the end of the Pleistocene. The yellow-cheeked vole (*Microtus xanthognathus*) was found at IF2. The 13-lined ground squirrel (*Spermophilus tridecemlineatus*) heather vole (*Phenacomys* sp.), and prairie vole (*Microtus cf. M. ochrogaster*) were found at both sites. *Microtus xanthognathus* and *Phenacomys* sp. are boreal species found far to the north, while *Spermophilus tridemenlineatus* and *Microtus ochrogaster* are mid-western species today. All four of these species are known from other cave sites in Virginia (MCDONALD et al, 1998; GUILDAY, 1962; GUILDAY et al, 1977).

The vast majority of mammal species found at IF2 and IF3 are either still present in Virginia or historically present and only extirpated in the last 200 years. Insectivores, including shrews and moles, include 4 species from IF2 and 5 from IF3. Bats (chiroptera) are the most abundant mammal order at both sites and include species of 4 different genera. Remains of the genus *Myotis* could not be identified to

species due to the fragmentary nature of the specimens (mandibles, broken maxillae). All of the bat species probably inhabited the cave during the time of deposition. Only a few tri-colored bats, formerly called the eastern pipistrelle, (*Perimyotis subflavus*) were noted living in the cave during the excavation of the fossil material.

Unidentified rabbits or hares were represented by isolated teeth, skull and mandible parts and ends of limb bones. *Sylvilagus* sp. and possibly *Lepus americanus* are present. Rodents had the highest ordinal diversity in both sites. The Allegheny woodrat (*Neotoma magister*) and deer or white-footed mice use the cave. Porcupine was found only in IF2 and was extirpated from Virginia in historic times (LINZEY, 1998). The remaining rodent species were probably brought into the cave by carnivores. Other than the dire wolf previously noted, all carnivores found in IF2 and IF3 remain present in Virginia. Carnivores are quite rare and include weasels at both sites, river otter at IF2, and raccoon and bobcat at IF3. All the carnivore species could have contributed prey items to the sites. The river otter was most likely responsible for bringing in the fish. Artiodactyls (even-toed ungulates) included a tooth fragment of an elk (*Cervus elaphus*), at IF2 and tooth parts of deer (*Odocoileus virginianus*) from IF3. The eastern elk (*Cervus elaphus canadensis*), was extirpated from Virginia in the middle of the 19th century (LINZEY, 1998).

3. Conclusions

The presence of three significant paleontological sites in a popular recreational cave is quite remarkable. Both IF2 and IF3 are perched above the main passage floor. All sites are well beyond the twilight-zone of the cave and the vast majority of the noted taxa were probably brought in by carnivores denning in the cave. The two radiocarbon dates from IF2 predate the last glacial maximum at ca. 25000 years, while the single date for IF3 post dates it and represents a terminal Pleistocene date. The similarity of the mammal faunas at the two sites, with noted exceptions, seem to indicate stability of the mammal fauna between those two time periods.

Acknowledgements

The present owners of the cave, The West Virginia Cave Conservancy, have enthusiastically supported paleontological research in Island Ford Cave. AMS radiocarbon dates were performed at the University of Arizona in the National Science Foundation-Arizona AMS Facility. Larry Smith facilitated the granting of Virginia cave excavation permits. Dr. Lynn Ferguson originally discovered the bone matrix site designated IF2. Many cavers assisted us,

especially in the excavation of the bear site.

5. References

- GRADY, F. (1997) The first record of *Arctodus simus* from Virginia. Selected Abstracts from the 1995 National Speleological Society National Convention in Blacksburg, Virginia, *Journal of Cave and Karst Studies* **59**, 58–59.
- GUILDAY, J.E. (1962) The Pleistocene local fauna of Natural Chimneys, Augusta County, Virginia. *Annals of the Carnegie Museum of Natural History* **36**, 87–122.
- GUILDAY, J.E., P.W. PARMALEE, and H.W. HAMILTON (1977) The Clarks Cave bone deposit and late Pleistocene paleoecology of the central Appalachian Mountains of Virginia, *Bulletin of the Carnegie Museum of Natural History* **2**, 87 pp.
- HOLSINGER, J.R. (1975) *Descriptions of Virginia Caves*. Virginia Division of Mineral Resources Bulletin 85, 450 pp.
- HUBBARD, D.A. JR, and F. GRADY (1999) Mammoth tooth found in Endless Caverns, Virginia. *Virginia Minerals* **45**, 1–3.
- LINZEY, D.W. (1998) *The Mammals of Virginia*. The McDonald & Woodward Publishing Company, Blacksburg, Virginia, 459 pp.
- McDONALD, J.N., R.E. ESHELMAN, F. GRADY, and D.A. HUBBARD, JR. (1998) The Late Wisconsin mammal fauna of Virginia. Appendix VI in *The Mammals of Virginia*, Donald W. Linzey, The McDonald & Woodward Publishing Company, Blacksburg, Virginia, 331–350.
- NOWAK, R.M. (1979) North American Quaternary *Canis*. Monograph of the Museum of Natural History, University of Kansas, **6**, 154 pp.

ROCK ART AND OTHER ARCHAEOLOGICAL CAVE USE ON THE NORTH AMERICAN PLAINS FROM CANADA TO NORTHERN MEXICO

JOHN GREER and MAVIS GREER

Dr. John Greer, Greer Services, Casper Wyoming USA, jgreer@GreerServices.com

Dr. Mavis Greer, Greer Services, Casper Wyoming USA, mavis@GreerServices.com

Rock art associated with caves is mostly pictographs (painted figures) although petroglyphs (engraved figures) occur in some entrance areas. Other kinds of cultural debris found in caves includes house remains, butchered bones, ocher mining, cold food storage, cultural deposits, log structures, human remains, stone and dirt platforms, placed objects and animal remains, and other items discarded from ritual. Natural light zones are divided into categories based on available light and personal orientation: Daylight, Twilight, Transitional Dark, and Dark zones. Rock art occurs in all zones, while other archeological manifestations mostly occur in Daylight to initial Transitional Dark zone settings. Rock art setting and position of other materials are generally evaluated relative to public and private use, or positions, although reevaluation of that distinction suggests the situation is more complex, and almost all rock art placement could be considered public in some sense. Most cultural materials in caves within the middle of the continent seem to date from the last 3500 years, with most in the last 1000 years. Implied function includes occupation in a protected setting, ritual activity, refuge areas for escape and hiding, ritual deposition of objects and animal remains, and disposal of the dead. Ease of reaching the desired location in the cave is highly variable, with open entrance areas easily accessed and other locations severely isolated by passage restrictions and complex navigation. Cave use throughout the region, as elsewhere, is part of generalized human activity and is not limited to particular cultural groups.

1. Introduction

Caves were used prehistorically by Native Americans through time for many purposes, with different activities occurring in different settings. The size, shape, and character of the utilized portion of the cave and the amount of available natural light influence what activity is conducted where, at any one time, but any activity, such as ritual resulting in rock art, can occur in any setting. Function of any activity can vary with different settings within a cave, or in caves of different characteristics.

Caves are measured from front to back, from mouth to most distant extent of the back wall. Rockshelters are wider than they are long (or deep), and caves are longer (or deeper) than they are wide. This traditional definition works well to distinguish cliff faces from deep caverns. Caves generally have some degree of light restriction because of an enclosed room, extended passageway, or complex underground system. The entrance may be large and allow entry of considerable light, or it may be small and difficult to negotiate. Large open entrance areas are essentially daylight settings, although they may change quickly in character and lead almost immediately into total darkness. Therefore, cave categories range from deep rockshelters to horizontal tubes, enlarged joints and cracks, large enclosed rooms, multiple rooms, multiple levels, larger complex systems, and expedition quality underground

caverns. Caves may be strictly horizontal, a combination of horizontal and vertical, or vertically oriented pits, and systems hundreds of meters deep that require use of technical equipment. Some caves are very large; others barely hold one person. It is within this broad definition of *cave* that we examine the kinds of use that occurred through the central part of western North America.

The North American Plains extend from Canada to Mexico and are bordered on the west by the Rocky Mountains. Extensive grasslands and sage-covered prairie are interrupted by island mountain ranges, such as the Black Hills of South Dakota and Wyoming, the Little Rocky Mountains of eastern Montana, and the high mesas of Colorado, New Mexico, and west Texas. These intermittent zones of limestone or sandstone are filled with caves of various sizes and shapes. Other cave systems also occur in the many rocky buttes and knolls filled with enlarged joints and collapsed depressions forming single rooms to vertical systems, such as Surratt Cave in New Mexico. Although only a few hundred caves on the Plains have been identified with archaeological remains, thousands of additional unexplored areas have a high potential for additional discoveries.

2. Natural Lighting Zones and Cave Forms

Archeological materials occur in all zones of natural light

and darkness, and setting obviously was selectively chosen. Caves provide darkness, isolation, visual effects, auditory stimulation, and various psychological reactions not available in daylight or in open-air settings, although some of the same conditions can be achieved at night in semi-enclosed cave rooms. Cave settings, however, can require greater preparation and energy for an activity. For example, ritual far below the surface in total darkness would require artificial light and could require transport of people and materials through restrictive areas of difficult access. Thus, lighting and location within a cave must be considered when analyzing remains within a cave. For purposes in categorizing archaeological remains, we have divided cave settings into four zones based on natural light and difficulty of personal orientation.

2.1 Daylight zone.

This is the immediate entrance where direct sunlight penetrates and lights up the area on a daily basis allowing for use without artificial light during daytime. The area could be illuminated by moonlight at night, which could limit the need for artificial light for some activities. This is universally the most common setting for archeological materials, and cultural remains include houses, hearths, bones, lithics, occupational debris, and rock art. Some remains appear to be the result of daily habitation activity, but some are clearly the result of ritual.

2.2 Twilight zone.

This shadow zone or penumbra is inside the cave in permanent shadow but with adequate light for visibility during most daylight hours. There is no direct sunlight, and artificial light may be necessary to view paintings on the walls and ceiling. There are numerous examples of rock art in these areas. The occurrence of structures and other features is unusual and probably associated with processing, storage, mineral extraction, or ritual in the eternal shadows, more than daily habitation.

2.3 Transitional dark zone.

This initial zone of total darkness, with absolutely no natural light, is away from the entrance but an area where natural entrance glow can be seen from a distance, either directly or with very little movement from the specific location. The cultural consideration is a beacon to guide one out of the cave, at least during the day, with little or no orientation problem and no fear of becoming lost. Traversing the route from a particular point toward the entrance may be a problem, depending on obstacles, but the distance and direction of exit are discernible. Rock art occurs through this zone, and other relatively rare items are almost certainly from ritual activity.

2.4 Interior dark zone.

Artificial light is necessary in this more distant area of total darkness far from the entrance and with no visible light orientation markers. Additionally, familiarity in maneuvering through such an environment in total darkness would be helpful. Exploration of deep pits would necessitate special equipment, although rawhide ropes, or special climbing tools, such as those used by honey climbers in Mexico, might suffice in some cases. Archeological materials are rare, although rock art and some human remains have been found in these areas.

In addition to natural light, shape and size of a cave are important when considering human activities. Whether the cave is a single room, a complex cavern, or a deep pit influenced how the cave was used. For our purposes in categorizing archaeological occurrence, we have divided cave forms into four categories.

2.5 Single room.

Entrance rooms of variable size, some very large and spacious, can have entrances that range from huge to small, nearly closed constricted openings. Some large rooms include twilight and dark zone settings, especially if they have restricted side passages or recessed ceiling domes, which were particularly attractive for rock art on the Northern Plains. Small cave rooms can support a Transitional Dark Zone if they have tiny entrances that open into larger rooms, such as the massive ceremonial U-Bar Cave in southwestern New Mexico. Rainbow Bear Cave in central Montana has a low duck-under entrance into a large room with hanging ceiling fans elaborately painted with ritual figures in a Transitional Dark zone requiring artificial light. Many single-room caves with restricted lighting appear to be associated with various forms of ritual activity (perhaps shamanism) more than simply expressing beliefs, myths, history, or other narrative aspects. Single-room caves with large entrances and better lighting conditions were used both as habitation and ritual locations, while sites with multiple rooms or horizontal passages were more often restricted for ritual and contain painted rock art, special structures, and unique artifact assemblages.

2.6 Multiple rooms and levels.

Archeological materials can occur in all four lighting zones in caves with multiple rooms and multiple levels. Zones can overlap, such as at Lookout Cave in Montana, where sunlight enters through a very small hole into an enclosed room and specifically lights up a small patch of wall with a red stylized bison while other figures around the room are in total darkness (M. GREER and J. GREER, 2007). At the

Comstock Airport Cave in southwest Texas an intensive chipping station and specialized artifacts were found in a very restricted lateral passage deep within the cave system, indicating specialized activity, while the nearby Whitehead Cave in Texas contains deep stratified cultural deposits in the dark zone of an interior room.

2.7 Cave systems.

Large complex horizontal or horizontal/vertical systems usually have cultural remains in the Daylight and Twilight zones. Frozen Leg Cave in southern Montana has pictographs of different ages and traditions in two large twilight rooms, plus other cultural materials and deposits in dark interior rooms and passages (J. GREER and M. GREER, 2006). Surratt Cave in New Mexico, a complex vertical system, has pictographs representing numerous ritual shrine locations all through the complex series of rooms and passages (J. GREER and M. GREER, 1997, 2002, 2007). Lick Creek Cave in central Montana had modern polychrome psychedelic art in the dark zone below the entrance — the only cave on the Northern Plains known to contain this early-1960s complex style and thus a unique representative of an important period of social change in American history. The U.S. Forest Service destroyed the panel, as graffiti, within a management concept of caves as static representations of a prescribed past, as opposed to dynamic cultural landscapes.

2.8 Vertical shafts.

Pits were used mainly for disposal of the dead. This includes both clean vertical shafts, some leading to rooms at the bottom of the entrance drop, and sloping entrance passages quickly dropping into a vertical shaft. There are several examples of this kind of occurrence in central Texas and northern Coahuila (see RALPH, 2009, this volume).

3. Kinds of Cultural Remains

Cultural remains in caves are as varied as they are in open-air sites or in rock shelters. While many materials are associated with various kinds of ritual activity, other activities also represented including habitation, mining, disposal of human remains, lost individuals, specialized activity, and refuge-safety for individuals or groups.

3.1 Rock art.

Rock art includes both painted images (pictographs) and engraved images (petroglyphs), and their presence in caves is often the most noticeable of cultural remains. Rock art most frequently occurs in entrance areas and in the Daylight Zone (J. GREER and M. GREER, 1997, 2002, 2007), with hundreds of examples, many just out of direct sunlight. The

large natural entrance of Carlsbad Caverns in New Mexico is one example. Variable function appears to include marking territory, vision quest, shamanism, hunting magic, and commemorating events.

Rock art, especially pictographs, also occurs in the Twilight Zone and Transitional Dark Zone. Several sites throughout the western Plains have paintings (and in rare cases, petroglyphs) in areas where artificial light is necessary to see the rock art, although navigating through that part of the cave may be minimally possible without extra light. In a few cases rock art extends from the Daylight Zone to the Dark Zone in a single site. At Triangle Cave in central Montana the wall from the cave entrance to the back of the phreatic tube is covered with paintings relating to shamanism. Long cracks and tubes in sandstone, though relatively rare, similarly extend back into near darkness. Two passages in the North Cave Hills and the Black Hills of South Dakota have walls intensively covered from front to back with carved petroglyphs.

Rock art in the Dark Zone is not common in this region, but it does occur. Caves in New Mexico provide some of the best examples. Surratt Cave has paintings throughout the vertically oriented system of passages and interior rooms, and Feather Cave is similarly painted in a system of enclosed rear rooms with extremely restricted access (J. GREER and M. GREER, 1997).

3.2 Ritual artifacts.

Rock art is usually assumed to be the result of ritual, as are some other cultural remains (J. GREER and M. GREER, 2006, 2007). Ceremonies leave behind offerings and trash, and discarded items and midden-like deposits may have been placed intentionally in organized arrangement (and later scattered by human and animal visitors), or they may be casual by-products of ceremonial activity. Such observed items include small artifacts (such as lithics or beads in prehistoric contexts and coins in historic contexts), figurines, pendants, and plants (including flowers, tobacco, and leaves), and candles or torches. Remains deliberately placed at specific locations deep within the cave, including small shrines at the base of rock art panels, have been found in such sites as Lookout Cave in Montana and Feather Cave, U-Bar Cave, and Arrow Grotto in New Mexico (J. GREER and M. GREER, 1997). Based on our ethnographic observations in northern Mexico, items are left whether two or three people cooperatively or communally conduct ceremonies in a room, with or without a larger group of people. The amount of debris left depends upon the number of participants, with more discarded material from larger

groups, or from repeated use of the location. Even when the group is large, the focus location within the cave is usually small and specific.

Ritual cave remains can also be identified from kind of object or from specific placement of objects. Skulls and other parts of power animals, such as bear or mountain lion, can be placed on ledges or constructed platforms within the cave, presumably as a request for supernatural assistance. Offerings can include finely made projectile points (often large spear points), feathers, flutes, beads, combs, prayer sticks, wands, and other decorative and ceremonial objects. Such offerings deep in the cave may be from a single person or associated with a group ceremony. Such offerings also may be buried or hidden. Conch shell masks probably transported from the Mississippi River area in the southeastern United States were found buried in a specially prepared area of Mask Cave in Montana, with its walls completely painted with red ochre.

3.3 Houses and habitation remains.

Constructed house floors or stone walls are occasionally found in the entrance areas of horizontal caves, and more rarely back into twilight areas, often associated with painted figures. Circular rock foundations for small wickiups are in the entrance of Juniper Cave in Wyoming, along with other house floors and painted figures, and other prehistoric stone foundations are in a nearby cave in Montana. In Montana and Wyoming, complete pole wickiups of the normal tall conical form — or the remains of such structures — occur in entrance areas. In other sites, interior rooms or small entrances are occasionally closed off with logs (M. GREER and J. GREER, 1997).

Frozen Leg Cave in southern Montana and Cave of the Logs in eastern Utah contain log structures, a large wickiup-like enclosure and a rectangular platform. These are horizontal systems of very difficult access, high on the canyon wall, and large logs, not available near the caves, were brought up to the entrances and transported with extreme difficulty into interior twilight and dark zone areas of the caves. The structures are considered associated with ritual, but their size and complexity are beyond normal wooden constructions in entrance areas.

Other kinds of habitation debris occur mostly in entrance areas. Common materials include hearths, stone and ceramic tools, chipped stone debitage, and butchered bones (J. GREER and M. GREER, 2006). At the heavily painted Two Hands Cave in Montana, a bone bead next to a hearth suggests additional activity. In the lower part of the entrance

passage of Horsethief Cave, a large cavern in Wyoming, ashy deposits with burned rock, chipped stone tools, debitage, and large amounts of butchered bone indicate repeated use of the interior entrance area for habitation.

Ice caves are common on the Northwestern Plains, and they undoubtedly provided refrigeration for prehistoric people, as they still did during historic times. No recognizable ritual remains or rock art have yet been recognized in caves with year-round ice deposits on the northern Plains, as they have in parts of western New Mexico. However, at Hand Stencil Sink in Montana the temperature at the bottom of the main room is nearly freezing, and there is evidence of wooden racks for hanging animals. The cave also contains rock art and an area of mineral extraction.

3.4 Stone and soil platforms.

At a few sites, the entrance area has been lined with stones, built up, and flattened, creating a platform. This suggests formal preparation of a habitation or ceremonial floor with a considerable amount of expended time and energy. Two entrance rooms in central Montana contain such platforms (GREER, 1995), both made by creating a stone facing of locally available rocks, and then filling in the faced area with dirt to create a flat floor. The floor provides a work area or place to sit in front of the entrance. Another site in Montana has a constructed rock walkway about 20 feet long leading away from the entrance and onto a flat area (THORSON and DAVIS, 1974).

3.5 Ochre mining.

Some caves on the Northern Plains contain mineral deposits used for paint pigment. An ethnohistorical reference describes Flathead Indians in Montana extracting red pigment from a limestone cave. Hand Stencil Sink in central Montana has several dark rooms and a small interior passage used for extraction of red iron oxide mineral, the main paint material in this region. Two negative handprints are located at the entrance of the cave.

3.6 Human remains.

Human remains are in caves for various reasons. Bodies are placed intentionally mostly in crevices or single rooms on the Northern Plains, such as Wyoming, or in larger cave rooms on the Southern Plains. In Texas and northern Mexico bodies also were both carefully placed and informally thrown into vertical shafts and vertically oriented small systems. Evidence of this practice has been found in the central and southwestern Texas, the Mexican state of Coahuila, and in the far eastern part of the Mexican state of San Luis Potosí (BEMENT, 1994; KUNATH,

2007:279-283; see RALPH, 2009, this volume). The small room surrounding a burial shaft in San Luis Potosí was covered with petroglyphs (GREER, 1974b; ARIAS FERNÁNDEZ, 2001:47-57). Remains are also found in deep, somewhat inaccessible parts of interior passages where people presumably died while wandering in the cave alone because they were lost. It is also possible, though unlikely, that bodies were carried far back into these remote areas for disposal. One such set of adult male remains about 5000 years old was found deep within Felton Cave in Texas. Another set of adult male remains about 8000 years old was found deep within another horizontal system in western Colorado (MOSCH and WATSON, 1997). In both cases, it is unknown if the person was lost, crawled into the cave to die, or if his body was placed there by other members of his social group.

3.7 Objects removed from caves.

Cave use is also evidenced by objects removed from caves and taken to another location either with or without modification. In some cases, most notably caves in northeastern Mexico (GREER, 1974a), cave formations have been intentionally broken and pieces removed from the cave, presumably for ceremonial use outside the cave. Likewise, cave crystals and pieces of formations have been found in archeological sites far from known caves. For example, a small stalactite artifact found on a river terrace in eastern Montana had been polished and then finely incised into what appears to be a highly decorated snake or salamander. The carved piece is at least 200 km from known cave areas.

4. Caves as Refuge Locations

Caves often blend into the surrounding environment and provide places for people to hide from enemies. Unfortunately, little is documented about use of caves as refuge locations. Boyd's Cave in southeastern New Mexico has a large flat sinkhole entrance, easily climbable, obscured and camouflaged by rock outcroppings and vegetation. The massive underground entrance chamber is documented to have been used by an entire band of Apache Indians hiding from the Army in the 1800s. Such use may have occurred more frequently than currently known, especially since there would be little, if any, remaining physical evidence for such a function. Human remains in some Texas caves are in locations and positions believed to indicate use of the cave for refuge during Indian attacks in the late 1800s (KUNATH, 2007:279-283).

5. Summary and Conclusions

People probably used caves across the Plains from the time

they entered the New World more than 13,000 years ago. The earliest dates for human remains in Texas caves are more than 11,000 years old (KUNATH, 2007:279-283). Cave use across the Plains from Canada to northern Mexico certainly dates back at least 8,000 years, but with widespread use during the last 3,500 years. Artifacts, cultural deposits, in-cave construction, and rock art all show an intensification of cave use during the last 1,000 years, with a dramatic increase in ritual use, particularly interior dark zone areas. Thus, use of caves in this region has a long and complex history covering thousands of years and many cultures.

Cave use, or site function, was equally complex, and caves were used by many cultures for both secular and religious reasons, with setting in the cave more important than available light. Daily habitation and most ritual activities were concentrated in areas with at least some entrance light. Rituals and ceremonies were conducted in all zones, perhaps because the Twilight Zone and many entrance rooms, especially enclosed rooms, at night are ideally dark and isolated from external influences of light and sound. At least some of the more elaborate and complex religious activities appear to have been reserved for the Dark Zone, suggesting that complete isolation, remoteness, and depth into the underworld were important. The characteristics of total darkness within a constricted space surrounded by solid rock, with the auditory effects of imagined supernatural noises and pounding trance-inducing reverberations of deep cavern passages cannot be replicated elsewhere. Also, the degree and intensity of interaction with the earth could change with the depth into which one goes into the cavern and the degree of isolation one would experience. Although activities could take place in enclosed entrance rooms, one would expect that those activities conducted far within the Dark Zone of a deep cavern would have different psychological, and presumably cultural, effects and meaning. Such use of the Dark Zone is reflected in various ways throughout this extended Plains zone, especially where paintings are far from entrances, and shrines were constructed far beyond the reach of natural light. Access to remote areas is often controlled by a tiny constriction — or notch — barely large enough for a small human body. Several such notches Surratt Cave in New Mexico are less than 30 cm in diameter. The back ritual rooms of Arrow Grotto, at the rear of the main passage in Feather Cave in New Mexico, are reached through a long low (est. 30 cm) passage ending at a very narrow notch entry into the first room. Comstock Airport Cave in Texas has an even smaller notch opening into a narrow passage with chipped stone debris from specialized ritual, and Whitehead Cave in Texas has a very narrow entrance leading down to the main

ritual area of a massive interior room. For other functions, such as ochre extraction or removing objects from the cave, the resource within the cave was more important than the degree of available light. Refuge use was dependent on the hidden nature of the entrance and the depth and complexity of the interior passages.

Rock art and ritual, and locations in sites in which they occur, are often evaluated relative to whether the art (or activity) was done for public use and observation, or if it was made only for the eyes of the specialist. The distinction is usually that *public* locations are those used by groups of people and thus have an outward orientation. *Private* locations are those presumably for use by only one or two people and have restricted viewing within a very small area. Based on this, it is generally assumed that a *public* place has a wall or altar facing a large, open area of ample space to hold a number of people and easily viewed by the group, while a *private* place is one occupied or utilized by only one person at a time, such as a small nook in the edge of a room, or a small isolated cavity. In applying these concepts to cave sites, particularly those with rock art, we have found that even the most private places still could accommodate a second or third participant, even if standing or lying a few feet away. The private location may not have been strictly private in the individual sense, and the private party may have consisted of a few, or even several, people. Equally important, however, there is no way to determine how many people may have participated in an activity in an open area that we class as public. It is possible that the number was very limited. Our ethnographic observations of ongoing native cave use in northern Mexico supports our views that *private* and *public* are inappropriate concepts relative to actual ritual conducted within a cave, usually taking place in a very restricted area, done privately by a specialist, but observed and supported by a group of people for whom the ceremony is actually intended.

In conclusion, evidence left in caves indicates that through time people have been attracted to caves as important locations for a variety of functions that range from secular to sacred. Each cave must be analyzed on its own from remaining cultural evidence to determine how it functioned, when it was used, and by which group or groups.

References

- ARIAS FERNÁNDEZ, R. (2001) *Sótanos de México, Abismos de Luz y Sombra*. Secretaria de Medio Ambiente y Recursos Naturales. México DF.
- BEMENT, L.C. (1994) *Hunter-Gatherer Mortuary Practices during the Central Texas Archaic*. University of Texas Press, Austin.
- GREER, J. (1974a) Aboriginally Occupied Caves in the Sierra de El Abra, San Luis Potosí and Tamualipas, Mexico. Association for Mexican Cave Studies, *Newsletter* 4(4):126–128. Austin.
- GREER, J. (1974b) Petroglyphs at Sótano de los Monos, Sierra de El Abra, San Luis Potosí, Mexico. Association for Mexican Cave Studies, *Newsletter* 5(1):23–30. Austin.
- GREER, J. and M. GREER (1997) Dark Zone Rock Art at Surratt Cave, A Deep Cavern in Central New Mexico. In *American Indian Rock Art*, Vol. 23, edited by S.M. Freers. pp 25–40. American Rock Art Research Association, San Miguel.
- GREER, J. and M. GREER (2002) Dark Zone Pictographs at Surratt Cave, Central New Mexico. In *Forward Into the Past: Papers in Honor of Teddy Lou and Francis Stickney*, *The Archaeological Society of New Mexico*, Vol. 28, edited by R.N. Wiseman, Thomas C. O’Laughlin, and Cordelia T. Snow, pp 37–46. Archeological Society of New Mexico, Albuquerque.
- GREER, J. and M. GREER (2006) *Archeological Use of Caves on the Northwestern Plains, USA*. Paper presented at the IFRAO – GLOBAL STATE OF THE ART, An International Rock Art Meeting at the UISPP XV Congress, Lisbon, Portugal.
- GREER, J. and M. GREER (2007) *Rock Art Associated with Ritual Cave Use in the Southwest and Northern Mexico*. Paper presented at the 72nd Annual Meeting of the Society for American Archaeology, Austin.
- GREER, M. (1995) *Archaeological Analysis of Rock Art Sites in the Smith River Drainage of Central Montana*. PhD Dissertation, University of Missouri-Columbia.
- GREER, M. and J. GREER (1997) *24BE601, Wickiup Cave, Addendum Site Form*. On file with the Montana SHPO Record’s Office, Missoula.
- GREER, M. and J. GREER (2007) *Lookout Cave, An Example of Ritual Cave Use in Montana*. Paper presented at the 72nd Annual Meeting of the Society for American Archaeology, Austin.

MOSCH, C.J. and P.J. WATSON (1997) An Ancient Rocky Mountain Caver. *Journal of Cave and Karst Studies* 59(1):10–14.

KUNATH, C.E. (2007) *50 Years of Texas Caving*. A&K Enterprises, San Angelo.

RALPH, R. (2009) Texas Caves, Texas Ossuaries. This volume.

THORSON, J. and S. DAVIS (1974) *24ME41 Site Form*. On file with the Montana SHPO Record's Office, Missoula.

SPELEO-ARCHAEOLOGY IN PAPUA NEW GUINEA: THE DISCOVERY OF PALEOLITHIC FLINT MINES ON THE SHORES OF THE SOLOMAN SEA

ROMAN HAPKA

Archéologue, membre de la Commission scientifique de la SSS et des clubs SCMN et SCPF, r.hapka@bluewin.ch

Speleo-archaeology in Papua New Guinea: The discovery of the mines of King Solomon. During the FFS Niugini 2001 » Caving Expedition on the island of New Britain, Papua New Guinea, archaeological prospecting was conducted in the caves of the Yombon region (Kandrian area), which borders the Soloman Sea. Ten underground sites were discovered, and most appear to have been quarries for the massive exploitation of the flint benches. Dating of tephras (volcanic ashes) from outdoor sites by Australian archaeologists indicate that the region has been occupied for more than 35,000 years. The discovery of these flint mines introduces new elements toward understanding the way of life of hunter-gatherers in the rain forest environment during the Paleolithic period.

C'est dans le cadre de l'expédition de la FFS Niugini 2001 dans l'île de Nouvelle-Bretagne faisant partie de la Papouasie-Nouvelle-Guinée, qu'a été effectuée une prospection archéologique des cavités de la région de Yombon (Kandrian) qui borde la mer de Soloman. Une dizaine de sites souterrains ont été repérés, la plupart fonctionnant comme carrières pour l'exploitation massive des bancs de silex. Des datations de téphras (cendres volcaniques) provenant de sites de plein air documentés par des archéologues australiens indiquent que la région est occupée depuis plus de 35.000 ans. La découverte de ces véritables mines de silex apporte des éléments nouveaux dans la compréhension du mode de vie des chasseurs cueilleurs du Paléolithique dans le milieu de la forêt tropicale.

1. Introduction

La Nouvelle-Guinée est la deuxième île en superficie du globe avec plus de 800.000 km², juste derrière le Groenland. Elle est divisée en deux états : l'Irian Jaya (Indonésie) qui occupe la partie orientale et la Papouasie, un état indépendant, qui occupe la partie occidentale, ainsi que plusieurs îles, dont la Nouvelle-Bretagne. Située entre la mer de Bismarck et la mer de Salomon, la Nouvelle-Bretagne a une superficie de près de 40.000 km², soit équivalente à la Suisse. Elle renferme la cavité la plus profonde de l'hémisphère sud, le gouffre de Muruk (-1178m).

La Nouvelle-Bretagne est une île volcanique qui se divise en deux zones ; une active au Nord qui comporte une dizaine de volcans en activité, dont le Mont Ulawun culminant à 2334m d'altitude ; une plus ancienne et non active au Sud comprenant de trois plateaux calcaires, la chaîne Hawlei, les Monts Nakanai (qui a part le Gouffre de Muruk, recèle également la méga doline de Naré), enfin la région de Kandrian.

C'est dans la région de Kandrian (Fig. 1) que s'est déroulé l'expédition spéléologique Niugini 2001 (Collectif Niugini 2001) au cours de laquelle ont été effectuées les diverses observations archéologiques. Le climat et la géologie s'y conjuguent à merveille pour donner une morphologie

karstique extrême de type polygonal, parsemé de vastes gouffres et recouvert d'une épaisse forêt primaire.

2. Aperçu Géomorphologie

La région de Kandrian (150°E-6°S) se situe sur la façade sud de la Nouvelle-Bretagne, dans la partie centrale de l'île au pied des Whiteman Range. Les plateaux karstiques qui ont été choisis comme objectif appartiennent à un ensemble de massifs calcaires constituant la majeure partie des bassins versants qui s'écoulent ici en direction de la mer de Salomon. Ces plateaux karstiques sont formés par les calcaires coralligènes du Yalam datés du Miocène. Ils forment une plateforme carbonatée de 400 à 600 m d'épaisseur inclinée vers le Sud entre 2000 m d'altitude et la côte.

Les plateaux calcaires reposent sur le socle composé par la croûte océanique d'âge oligocène. Sur la zone côtière Nord se développe une série de volcans de type explosifs. Ce volcanisme est particulièrement actif puisqu'il a produit la plus forte explosion de l'histoire de l'humanité dans la caldera du Dakataua. La ville de Rabaul a été détruite en 1994 par l'explosion des volcans Tavorvur et Vulcan. Encore actuellement, des tonnes de poussière sont expulsées journalièrement par ces deux volcans, alors qu'ils sont en période de calme relatif. Lors des éruptions cataclysmiques des quantités gigantesques de cendres retombent sur l'île

et la jungle est détruite sur plusieurs kilomètres de rayon; phénomène qui a son importance dans l'évolution du karst

et dans l'archéologie locale (Collectif Niugini 2001).

Le climat est équatorial avec des particularités insulaires et des périodes de moussons. En ce qui concerne la façade Sud, la période de novembre à avril est celle de la "saison sèche", car les vents dominants sont de secteur Nord et les précipitations sont partiellement barrées par la crête de l'île. Par conséquent, il ne pleut généralement que l'après-midi. Ces précipitations sont violentes, voire très violentes, plus de 200 mm mesurés le 3 février 2001 en moins de 3 heures... avant destruction du pluviomètre!

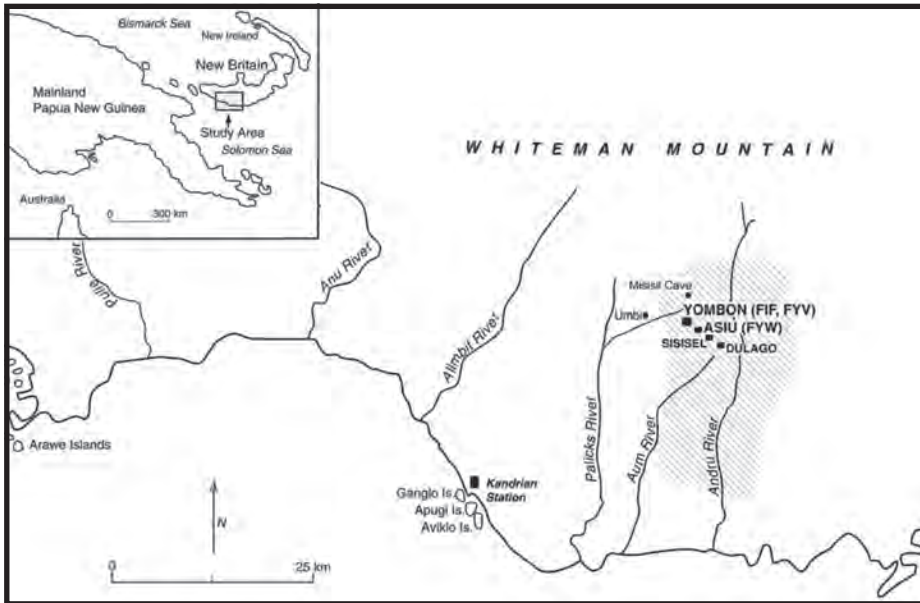

Figure 1: Situation de la région de Kadrian en bordure de la mer de Salomon (d'après PAVLIDES, 2004).

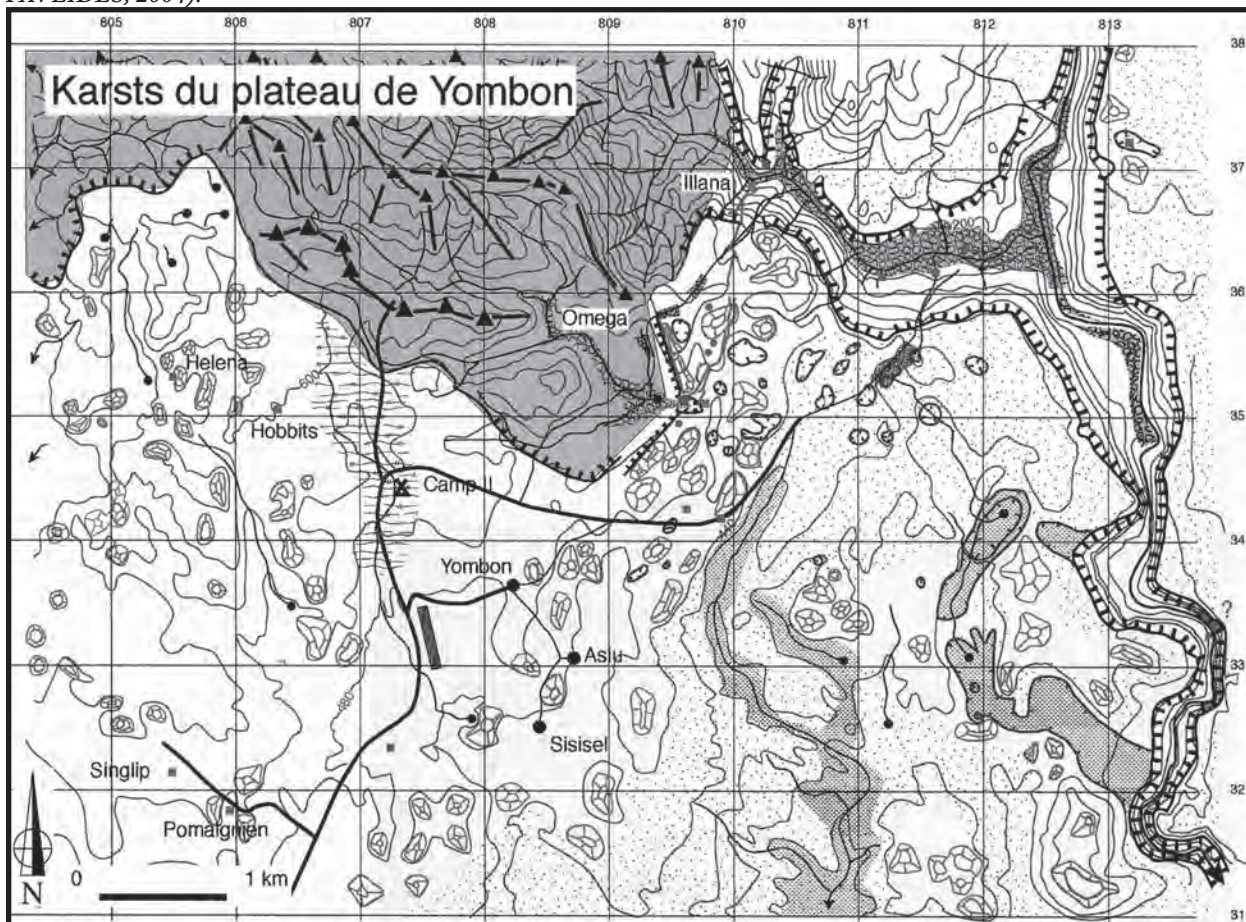

Figure 2: Aperçu géomorphologique des karsts du plateau de Yombon et situation des cavités explorées (d'après Collectif Niugini 2001).

La Nouvelle-Bretagne est la région où les pluies journalières les plus importantes ont été mesurées (400 mm/j à Kandrian).

Ce régime hydrologique quotidien très contrasté a une répercussion quasi immédiate dès que le sol est un tant soit peu imperméable. La concentration des écoulements en surface est très rapide et alimente des pertes au fond des dolines jointives qui criblent littéralement les plateaux calcaires. La conséquence principale pour l'exploration spéléologique est que les réseaux actifs sont en crue tous les jours ou presque pendant l'après-midi. Il s'agit alors, soit d'être déjà ressorti des cavités les plus étroites, soit de monter un bivouac de fortune dans les plus grands réseaux. La décrue s'effectue durant la nuit, ce qui permet de reprendre l'exploration au petit matin (Collectif Niugini 2001).

3. Le Plateau de Yombon

On accède au plateau de Yombon par une piste forestière damée construite par une compagnie d'exploitation forestière malaise entre 1994 et 1996. Au bout de cette piste se trouve une zone d'exploitation qui s'étend autour du village de Yombon sur un plateau parsemé de collines. Le campement principal a été installé à 2km du village, à proximité de la zone de contact entre les basaltes et les calcaires (Fig. 2).

Le paysage karstique est constitué de vastes secteurs aplanis ou les dépressions alternent avec des zones de collines (buttes karstiques). Le plateau est limité au Nord par le bassin versant perché de la Siki River et le canyon de la vallée de la Winam River. Au Nord-ouest, il y a continuité topographique entre la surface du plateau calcaire et les crêtes basaltiques légèrement en relief.

4. L'occupation et les Activités Humaines Modernes

Les vallées environnantes, plus difficiles d'accès, sont très peu occupées et la présence de petits cours d'eau pérennes à la surface du plateau de Yombon en fait au contraire une aire attractive. Les implantations sont dispersées autour d'une mission religieuse située près d'une piste d'atterrissage en terre. Lorsque les ponts sont praticables des véhicules 4x4 peuvent venir jusque-là.

L'activité principale des populations papoues est une agriculture de subsistance dans des jardins clos formant des trouées dans la jungle. Ces derniers sont abandonnés après seulement quelques saisons de culture. Ces pratiques impliquent un certain nomadisme et les anciens villages abandonnés ne sont pas rares.

A cette activité traditionnelle et locale s'ajoutent les activités extérieures plus ou moins répétées et plus ou moins permanentes. La plus permanente est l'installation d'une mission religieuse des New Tribes (traducteurs de la bible en langue locale) qui assure sporadiquement un enseignement un peu orienté et dispense quelques soins de première nécessité. Pour les affections plus graves la population locale ne doit compter que sur elle-même pour rejoindre à pied un dispensaire situé à plus de 30km ou "l'hôpital" de Kandrian à plus de 60km.

L'autre activité qui a marqué le paysage et la société papoue de façon quasi irréversible est l'exploitation de la forêt par une compagnie malaise : ouverture d'une piste carrossable, déforestation, instauration d'une économie de dépendance financière déstabilisant les structures sociales traditionnelles. Les incursions d'explorateurs et de scientifiques, telles que les campagnes de fouilles archéologiques australiennes et les expéditions spéléologiques françaises sont occasionnelles (Collectif Niugini 2001).

5. Explorations Spéléologiques

Trois grands types de réseaux spéléologiques ont été reconnus durant les trois mois de séjour de l'expédition Niugini 2001 (février – avril 2001) :

- les collecteurs alimentés par des pertes sur le Haut Plateau;
- les gouffres pertes de contact (Arrakis et Omega-Illana) et les dolines puits;
- les réseaux cutanés et les grottes tunnels.

Nous nous limiterons ici à la présentation de quelques découvertes effectuées sur le plateau de Yombon, région qui à livré à la fois les plus belles explorations au travers du réseau très aquatique Oméga – Illana et plusieurs cavités (réseaux cutanés et grottes tunnels) recelant d'importants vestiges archéologiques du Paléolithique.

6. Le Réseau Actif Oméga–Illana

La dépression d'Oméga (Fig. 3) est un grand cirque bien visible sur les photographies aériennes. Le site est impressionnant, la rivière Siki, s'écoulant sur les basaltes, bute contre une falaise calcaire de près de 100 m de hauteur. L'eau s'infiltre dans une vingtaine de pertes non pénétrables ; lors des crues journalières, le fond de la vallée s'inonde et forme un lac.

Par un orifice discret, sous des blocs effondrés et des troncs charriés par les crues, on atteint le sommet d'une diaclase au fond de laquelle gronde une rivière au bas de 70m de puits.

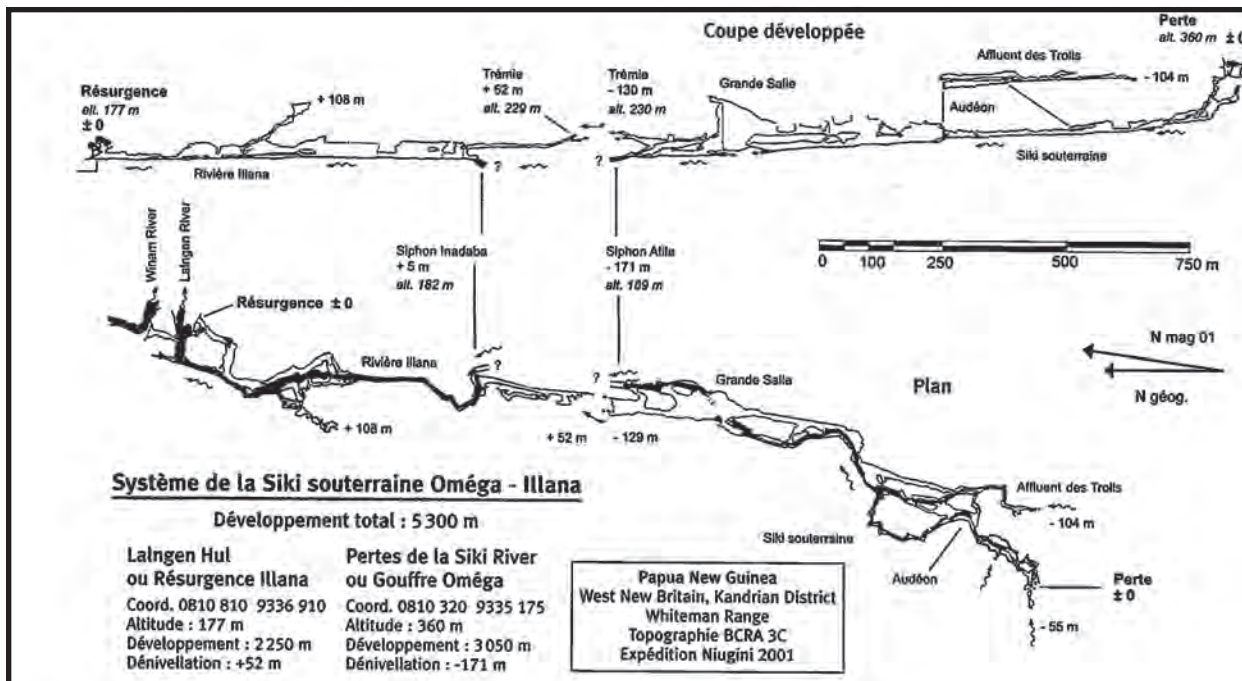

Figure 3: Topographie du tracé souterrain de la rivière Siki (perte d’Oméga – résurgence d’Illana (tiré de Collectif Niugini 2001).

L’amont de la rivière a été remonté jusque sous une trémie qui se situe exactement en dessous de la zone des pertes de la surface; c’est-à-dire que le lac de crue est pour ainsi dire suspendu au-dessus de la galerie. Vers l’aval, la rivière cascade dans un conduit de bonnes dimensions; en rive gauche, une importante arrivée d’eau, constitue le cours souterrain de la rivière Siki. Son débit est d’environ 1m³/s en basses eaux.

Sur le sol et les terrasses sédimentaires, des blocs de basalte noir contrastent avec la blancheur de la roche calcaire. Plusieurs passages donnent accès à un niveau fossile et superbement bien concrétionné. L’actif s’écoule en bassins profonds et disparaît parfois avant de réapparaître entre les blocs d’une grande salle large et haute de près de 100m. La rivière se fraie un chemin plein Nord, jusqu’à une voûte basse annonçant un siphon terminal tout proche. La galerie, de vaste dimension, passe au-dessus du siphon et vient buter sur un éboulement d’où souffle un courant d’air sensible, qui correspond à la trémie terminale de la rivière Illana. La topographie indique une distance d’environ 50m entre les deux terminus. Le développement total de la perte d’Oméga dépasse les trois kilomètres (-171m).

La résurgence de la rivière Siki est située aux abords de la rivière Winam dans une vallée encaissée; elle a pris le nom de rivière Illana. Outre le porche actif, trois entrées fossiles donnent accès à la zone d’entrée. Après une centaine de mètres ces galeries se rejoignent en un beau canyon parcouru par la rivière aux eaux troublées par du guano. Peu après,

une vaste galerie fossile en rive droite laisse le choix entre le dépôt de guano infesté de mygales ou un bain dans l’actif après avoir traversé la rivière encombrée de blocs de basalte arrondis. La rivière se poursuit en bassins profonds à la suite d’un second passage fossile, jusqu’à un coude au-delà duquel on rencontre un siphon inattendu mais bien réel.

Une escalade donne accès à un second niveau, d’abord actif puis fossile, se dirigeant plein Sud. Au terme de cette galerie longue de 200m, on atteint l’autre côté de l’éboulement terminal d’Oméga. Le développement total de la résurgence d’Illana atteint 2250m (Collectif Niugini 2001).

7. La Grotte Archéologique de Misisil

Située à mi-chemin entre la perte d’Oméga et la résurgence d’Illana, la grotte tunnel de Misisil est connue des Papous qui l’utilisent comme abri. L’imposant porche, d’une vingtaine de mètres de hauteur, donne accès à une galerie à fond plat et sableux encombrée de blocs. On peut gravir une coulée stalagmitique et ressortir par un orifice au plafond de la galerie (Fig. 4). En aval du porche, la suite de la galerie est effondrée et se poursuit en forte pente dans la forêt en direction du nord.

La grotte de Misisil est d’une importance particulière, puisque c’est ici qu’en 1980, l’archéologue australien Jim Specht a découvert les premiers vestiges d’une occupation Paléolithique en Nouvelle-Bretagne (SPECHT et al., 1981). Ces données ont été par la suite corroborées par d’autres

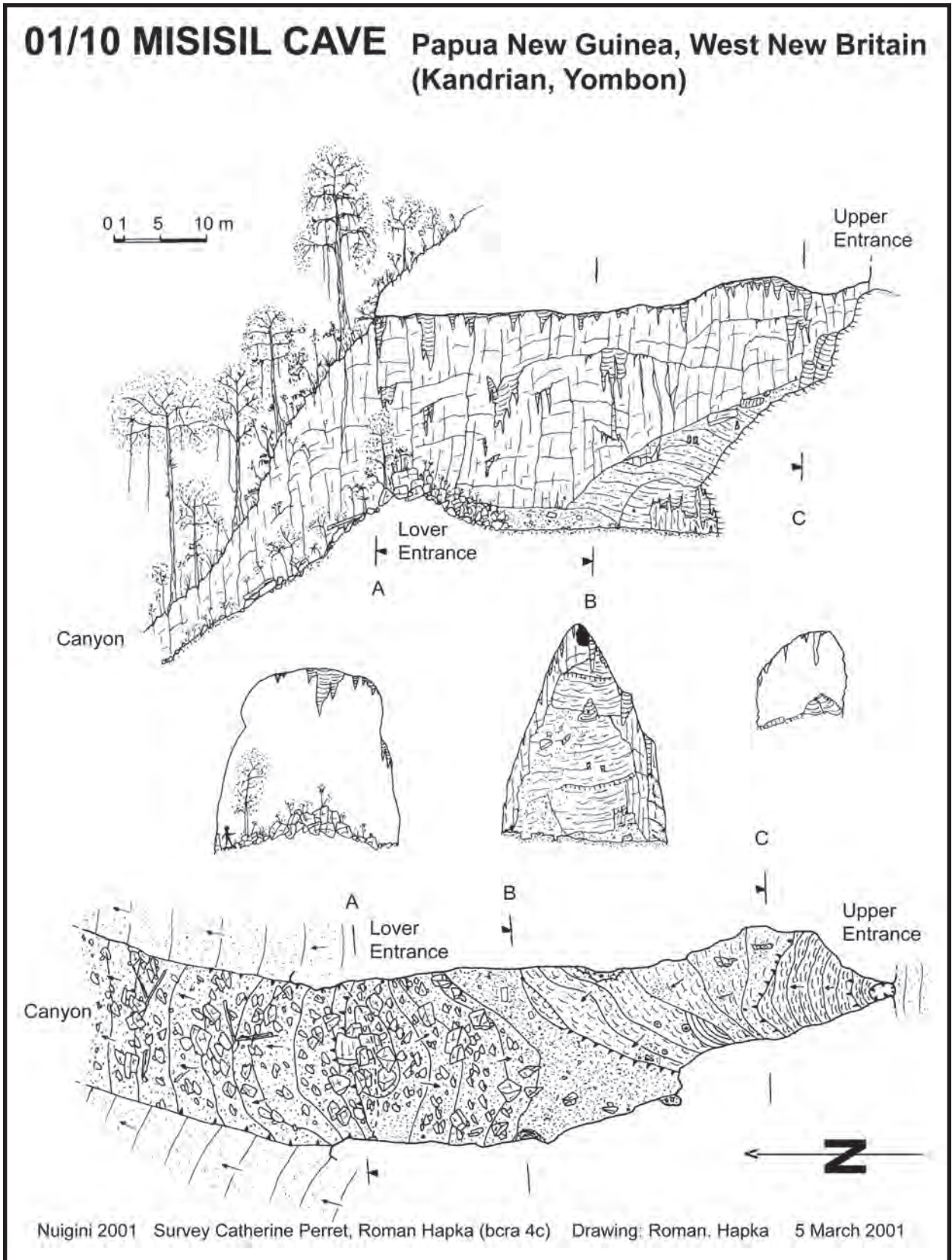

Figure 4: Topographie de la grotte de Misisil.

fouilles menées dans la région (VALIDES et GOSDEN, 1994). Des témoins de niveaux culturels et d'occupation du Pléistocène récent (35000 BP) ont ainsi été découverts lors des fouilles de sites de plein air sur le plateau de Yombon. Ces sites de surface, les plus anciens de Nouvelle Bretagne, semblent actuellement également constituer les plus anciens sites de plein air de forêts humides découverts dans le monde (VALIDES, 2004).

8. Karst, Basalte et Retombées Volcaniques

Les formations superficielles basaltiques provenant de l'érosion du socle et les retombées volcaniques (dénommées téphras) participent de façon notable à l'évolution du karst de Nouvelle-Bretagne. Les retombées de cendres volcaniques alimentent massivement les couvertures du sol et le remplissage des cavités. Dans le secteur de Yombon, les colluvions des vallons à fond plats et les zones d'entrées de certaines cavités présentent en alternance des couches de téphras sur toute l'épaisseur du sol. Des perspectives importantes s'ouvrent à partir de ces résultats, en particulier pour la recherche archéologique.

En effet, la conservation, la structure et la chronologie des sites de la forêt primaire de la Nouvelle-Bretagne sont étroitement connectées avec l'histoire du volcanisme insulaire. Les couches de téphras qui ont détruites et scellées des paysages entiers, agissent aujourd'hui comme d'excellents marqueurs stratigraphiques (Collectif Niugini 2001).

Les fouilles menées par Specht (SPECHT et al., 1981) dans la grotte de Misisil et par l'équipe de Pavlides en 1989 près de Yombon (PAVLIDES et GOSDEN, 1994 ; PAVLIDES, 2004) ont permis de documenter et de dater (de 2'500 BP à 33'500 BP, datations radiocarbone) cinq différents niveaux de téphras - entrecoupés de niveaux sédimentaires comportant des vestiges archéologiques - dans les coupes stratigraphiques (Fig. 5).

9. Grottes et Mines de Silex

Qui dit Paléolithique comprend outils en pierre taillée et dans ce domaine certaines grottes du plateau de Yombon font figure de cavernes d'Ali Baba. Dans une dizaine de cavités, les lampes des spéléologues font miroiter des centaines d'éclats et d'outils façonnés dans le plus pur silex. La plupart de ces sites ont fonctionné comme carrière pour son extraction massive. Les veines de silex sont mises à nu sur les parois des galeries par l'érosion des rivières.

Plus d'une centaine d'outils taillés et des milliers d'éclats de taille ont été trouvés (sans aucune activité de fouille archéologique) dans les talus des ruisseaux souterrains, pris

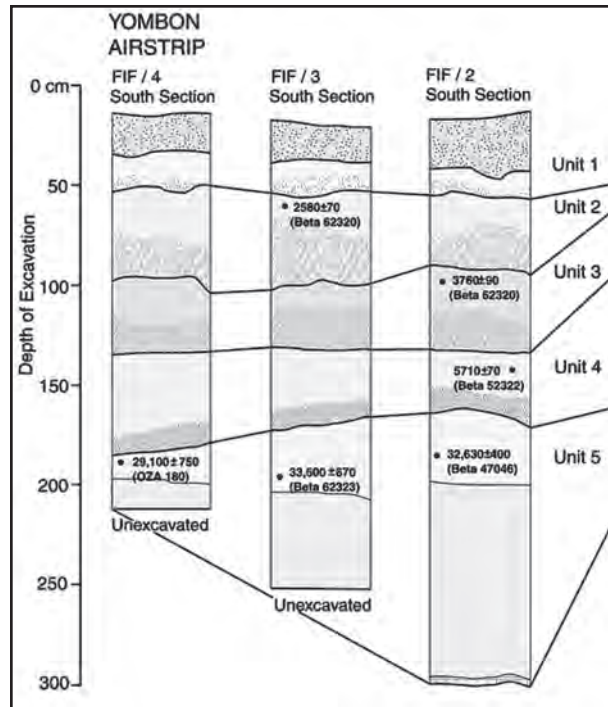

Figure 5: Relevés stratigraphiques des sites de surface du plateau de Yombon (d'après PAVLIDES, 2004).

dans des dépôts alluvionnaires remaniés et déplacés par l'eau. Quelques exemplaires particulièrement remarquables ont été dessinés et photographiés à titre d'exemple (Figs. 6 et 7), pour ensuite être remis en place (HAPKA, 2001).

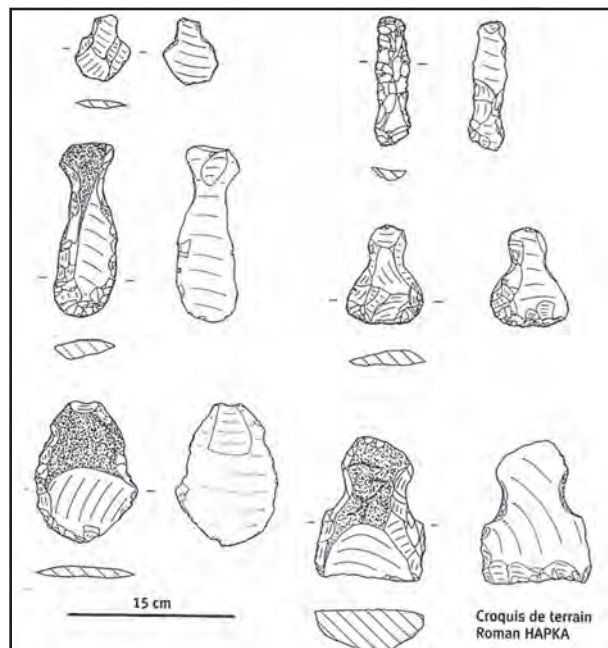

Figure 6: Croquis de quelques exemples d'outils en silex (haches et lames) découverts dans les grottes du plateau de Yombon.



Figure 7: Une hache en silex brun longue de 10cm photographié in situ dans les sédiments d'un ruisseau souterrain.

La grande quantité d'outils taillés découverts en l'espace de quelques explorations spéléologiques dans quatre cavités du plateau de Yombon, ainsi que les nombreux éclats de silex repérés dans trois autres (Table 1), est à comparer aux 29 outils et éclats datés récoltés durant les fouilles effectuées par les archéologues australiens dans les sites de surfaces de la région.

Dans une récente étude, l'archéologue australienne Pavlides (PAVLIDES, 2004) indique toujours ne pas connaître l'origine exacte des sources d'extraction du matériel lithique Pléistocène ; même si des nodules de silex sont présents *in situ* dans les calcaires Miocène de la région (affleurements dans de profondes pertes) et dans des dépôts alluvionnaires secondaires des rivières. La haute qualité du silex de l'outillage des sites de surface indique qu'il provient exclusivement de nodules de silex extraits directement des couches géologiques; c'est-à-dire de sources primaires. Cela alors même qu'une autre source de matière première (de moins bonne qualité cependant) est présente à profusion dans le lit des rivières. D'autre part, les éclats, récoltés dans les sites de surface et montrant divers stades de fabrication d'outils, indiquent une certaine proximité

Cavité	Vestiges archéologiques
Helena Hul Dév. 900m Dén. 26m	De nombreux outils (haches, grattoirs, lames) en silex ainsi qu'un certain nombre de haches en pierre verte et en basalte ont été repéré aux alentours des diverses entrées de Helena Hull. Un matériel abondant est également présent à l'intérieur des pertes, sans doute transporté par les eaux de crue. Les entrées supérieures (fossiles) comporte du matériel et ont pu servir d'habitat temporaire (peu d'espace disponible). Les rognons de silex présents dans la rivière et quelques bancs dans la cavité pourraient indiquer une zone d'extraction.
Talu Hul Dév. 40m, Dén. 0m	Outil (lame) en silex, quelques éclats. Important dépôt de sédiment, site d'habitat possible.
Pomalngen Hul Dév. 605m Dén. 15m	Des outils (haches, lames) et éclats en silex sont présents à proximité de la résurgence. Des outils et des éclats ont été repérés tout au long de la cavité. Des bancs de silex indique une zone d'extraction.
Singlip Hul Dév. ~500m Dén. ~-10m	Le lit du ruisseau souterrain est constitué d'épais dépôt de silex dans toutes les étapes de façonnage (rognons, nucléus, éclats, outils divers). Les bancs de silex des parois ainsi que les milliers de pièces présentes indiquent un important site d'extraction.
Rivière des Hobbits Dév. 500m, Dén. 15m	Présence d'éclats de silex.
Perte sur la Crête Dév. 20m, Dén. -15m	Une hache de silex a été trouvée au fond de la dépression, directement à l'entrée du méandre par où disparaît l'eau.
Pui Hul Dév. ~50m reconnus	Présence d'éclats de silex et d'une meule dans la zone d'entrée.

Table 1: Inventaire des cavités archéologiques du plateau de Yombon découvertes lors de l'expédition Niugini 2001.

des sites de production. Valides émet donc l'hypothèse d'un développement local d'une activité d'extraction permettant de se procurer une matière première de haute qualité: probablement des mines souterraines situées dans les pertes environnantes. Les découvertes effectuées quelques années auparavant lors de l'expédition Niugini 2001 viennent confirmer cette hypothèse.

10. Conclusion

La présence en grande quantité d'outils et d'éclats de silex dans diverses cavités découvertes et explorées sur le plateau de Yombon lors de l'expédition Niugini 2001 vient confirmer l'hypothèse des archéologues australiens: les paléolithiques occupant, voici plus de 35'000 ans, la forêt tropicale bordant la mer de Salomon, prospectaient la région à la recherche de sites d'extraction de silex. Les recherches spéléoarchéologiques ont eu pour résultat le repérage d'un certain nombre de sites probables: diverses grottes de la région permettant d'accéder directement aux

veines de silex de la meilleure qualité (Fig. 8). La présence de milliers d'éclats indique que les paléolithiques pratiquaient également une partie des opérations de taille dans ces véritables mines souterraines.

Cette découverte vient conforter les recherches de Pavlides qui conclue que « *les premiers colonisateurs des diverses îles de la Papouasie étaient des chasseurs-cueilleurs aptes à se mouvoir le long des côtes et à se procurer toutes les ressources que leur offrait la forêt tropicale* », y compris des ressources lithiques de très haute qualité.

Bibliographie

Collectif Niugini (2001) Niugini 2001 : retour chez les Papous.... Spelunca, 83, 11-28.

HAPKA R. (2001) Paléopapou 2001 : des archéologues dans la brume. Actes du 11^e Congrès National de Spéléologie, 296.

SPECHT J., I. LILLEY, et J. NORMU (1981) Radiocarbon dates from West New Britain, Papua New Guinea. Australian Archaeology, 12, 13-15.

PAVLIDES C., et C. GOSDEN (1994) 35.000 year old sites in the rainforests of West New Britain, Papua New Guinea. Antiquity, 68 (260), 604-610.

PAVLIDES C. (2004) From Misisil Cave to Eliva Hamlet: Rediscovering the Pleistocene in the Interior West New Britain. Records of the Australian Museum, Supplement 29, 97-108.



Figure 8: Explorateur des temps modernes redécouvrant un banc de silex exploité anciennement.

SAND BLASTING AS AN ARCHEOLOGICAL RESTORATION TOOL IN CAVES

RAY KEELER

National Speleological Society, USA

Abstract

Modern graffiti (within the last 50 years) has caused significant, adverse impact to archeological sites in caves. Access, nearby population centers, stable and easily available lighting, and spray paint have provided the tools to allow large scale vandalizing of many caves. Graffiti removal in caves can be achieved on a large scale to repair/restore the cave to its natural condition.

NSS cavers have developed a methodology where up to three in-cave teams can work independently addressing graffiti tags in their areas. The primary graffiti removal tool is sandblasting. Since 2001, nine caves in six states have been completely or partially cleaned of graffiti. Latest of the restorations have been Sandia Cave, New Mexico. Sandia Cave is a National Natural Landmark primarily for archeological discoveries made in the late 1930s. The cave is a single, 139 m, phreatic, horizontal passage which has received significant visitation and graffiti over the last several decades.

The Sandia Cave site preparation for preserving historic and pre-historic markings has included systematic photographing the cave's walls and ceiling. Over 1,100 digital photos have been taken. The photos have been correlated to survey stations and logged for possible significance. Areas of concern have been reviewed prior to the graffiti removal trips. Markings deemed to be saved have been noted and tagged. The type of blast media chosen allowed both coarse and fine graffiti removal. Individual layers of spray paint can be removed while protecting the historical and pre-historical layer below.

A trailer mounted compressor with 450 m of large-diameter, high-pressure hose provides compressed air. Near the work sites, the air is branched to three smaller diameter hoses through a pressure regulator. 180 m of smaller hose allows each team to eliminate specific tags. Electricity for the project lighting and electric brushes is supplied through a generator and over 580 m of extension cords. Additional graffiti removal is by electric brushes.

CONTRIBUTIONS OF EDWARDS PLATEAU CAVE DEPOSITS TO PLEISTOCENE VERTEBRATE PALEONTOLOGY

ERNEST L. LUNDELIUS JR

Department of Geological Sciences, Jackson School of Geosciences and Vertebrate Paleontology Laboratory, Texas Natural Science Center, University of Texas, Austin, Texas, USA

Vertebrate fossil assemblages from 37 caves and shelters on the Edwards Plateau of Central Texas are the basis for the reconstruction of the late Pleistocene faunal history of this area. These deposits are unevenly distributed in a geographic area of about 75,000 km² and, with one known exception, a temporal span of about 25 ka. The vagaries of mode of accumulation, geomorphology and cave morphology have resulted in many different types of deposits. Many fossiliferous cave deposits represent very short intervals of time. Others represent a more extended time frame. Some contain deposits and faunal remains that are the result of exceptional accumulation and taphonomic processes and provide samples of growth stages of one or more extinct species.

Two caves, which were opened by modern excavations, indicate that caves on the Edwards Plateau did not remain open for extended periods of time. One, containing deposits with reversed remnant magnetism indicating a date greater than 780 ka, was exposed in a quarry operation. The other, with multiple debris cones dating 24 ka, 15 ka and 13 ka, was discovered in a drilling operation. This suggests that caves do not stay open long enough on the Edwards Plateau to accumulate long unbroken sequences of deposits. Correlating the data from the various cave deposits, a record of faunal change documenting the extinction of large mammals and the disappearance of non-analog associations and extra-limital taxa has been established.

1. Introduction

Caves are a rich source of fossils from at least the Mississippian Period (LUNDELIUS, 2006). Plio-Pleistocene cave deposits have contributed significantly to our knowledge of terrestrial faunas of that time interval in many parts of the world. Caves span the gamut from relatively open shelters to completely enclosed rooms or passages to completely sediment filled caves that are known only through modern human excavations such as quarries, road cuts or drilling operations. Humans have frequently utilized the open shelters as living areas and strongly influenced the materials that are found in some deposits.

The Edwards Plateau of Central Texas is underlain by middle Cretaceous limestones that contain a large number of caves.

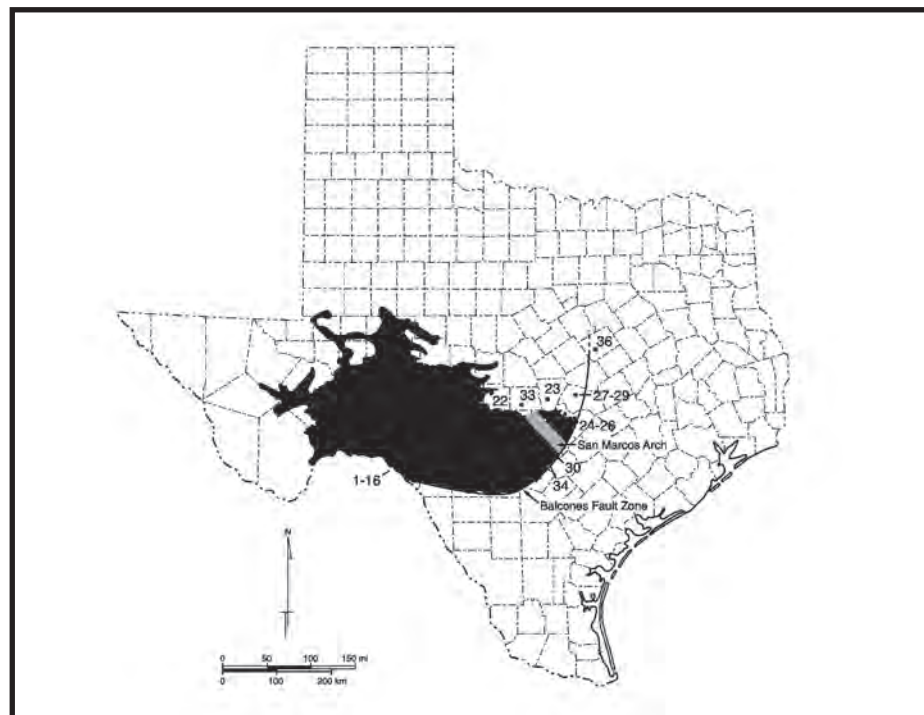

Figure 1: Map of Central Texas showing the Edwards Plateau (gray area) and caves that have contributed to the fossil record of the Quaternary fauna of the Edwards Plateau.

Vertebrate fossil assemblages from 37 caves and shelters on the Edwards Plateau of Central Texas are the basis for the reconstruction of the late Pleistocene faunal history of this area (Fig. 1). These deposits are unevenly distributed over a geographic area of about 75,000 km² and, with one known exception, span a period of about the last 25,000 years

2. Mode of Accumulation

Remains of animals accumulate in caves in a number of ways. Caves with open vertical shafts may act as traps for unwary animals. Hitzfelders Cave and Devils Sinkhole are examples on the Edwards Plateau but only the former has produced any bones, and these have not been studied. Some bones may be derived from animals that die on the surface of the surrounding area and are washed into the cave along with the sediments. Salamanders, bats, swallows and packrats spend much or all of their lives in caves. Their bones become incorporated in cave sediments after their death. Some species, such as peccaries, use shelters as refuges during extremes of weather. Predators frequently use caves and introduce remains of their prey and use them as shelters for their young. Human use of caves and shelters results in the introduction of bones other than those of food items. These various modes of accumulation introduce different biases into the fossil record, and all of these modes are found in caves on the Edwards Plateau.

3. Age of Cave Deposits

With one exception, all the cave deposits of the Edwards Plateau that either have been isotopically dated or whose ages can be inferred from archaeological materials have accumulated in the last 25,000 years. The exception is Fyllan Cave and the adjoining Kitchen Door locality, which were discovered in the process of a limestone quarry operation. This cave, which is completely filled with sediment, has no known surface expression and is only visible on the quarry face. The sediment has reversed magnetic orientation, which gives it an age of at least 780,000 years (TAYLOR, 1982; WINKLER AND GOSE, 2003). The vertebrate fauna from these deposits is assignable to the Irvingtonian North American Land Mammal Age. The other known cave deposits on the Edwards Plateau span the last 25,000 years but mostly give short "snapshots" of the faunas. The sequence has to be pieced together making allowance for the faunal diversity due to the east-west climatic gradient.

The reason for the lack of long sequences in the cave deposits appears to be that the entrances did not remain open for long periods of time. All of the older deposits, Fyllan Cave, the older unit in Friesenhahn Cave and all the fossiliferous units in Laubach Cave (Inner Space Cavern) are related to

openings that are now closed.

4. Faunal Change

The Pleistocene faunas from the cave deposits contain three elements: extinct species, extant extralimital species, and extant species currently living in the area. The extinct group contains many taxa that were distributed over a large part of North America such as mammoth *Mammuthus*, saber toothed cat (*Smilodon*), scimitar cat (*Homotherium*), camel (*Camelops*), sloth (*Paramylodon*), giant lion (*Panthera atrox*), and large wolf (*Canis dirus*). Many of the extinct taxa common in the eastern and midwestern United States such as American mastodon (*Mammut*), stag moose (*Cervalces*), giant beaver (*Castoroides*), woodland musk ox (*Bootherium*), and long nosed peccary (*Mylohyus*) are either absent, rare or are confined to the eastern edge of the Edwards Plateau. A few, such as the two large armadillos (*Holmesina* and *Dasybus bellus*) and the glyptodont (*Boreostracon*), are primarily southeastern in their distributions. Others such as the Shasta ground sloth (*Nothrotheriops*), shrub ox (*Euceratherium*), and mountain deer (*Navahoceros*), are found primarily in the western part of North America and are absent from the Edwards Plateau faunas.

Several extant extra-limital species no longer live on the Edwards Plateau. These are arvicoline rodents such as the bog lemming (*Synaptomys cooperi*), meadow vole (*Microtus pennsylvanicus*), pine vole (*Microtus pinetorum*), prairie vole (*Microtus ochrogaster*), shrews such as the masked shrew (*Sorex cinereus*), short tailed shrew (*Blarina brevicauda*), eastern chipmunk (*Tamias striatus*), and ermine (*Mustela erminea*). All of these species currently live to the north and/or east of Central Texas today in areas with somewhat cooler and moister climates.

These regional differences in the extinct elements of the faunas suggest regional climatic and ecological differences. When this is combined with the presence, in the Pleistocene, of extant extralimital species whose ecological requirements are known, the differences in the distributions of the extinct species become more understandable. Within Texas, the change in the makeup of the faunas at the Balcones Escarpment that separates the Edwards Plateau from the Gulf Coastal Plain, is marked.

Another characteristic of these Pleistocene faunas is the occurrence in most localities of associations of species that do not coexist in the same areas today. Examples are the hispid pocket mouse *Chaetodipus hispidus* and *Mustela erminea* found together in Cave Without a Name in Kendall County, *Synaptomys cooperi* and *Chaetodipus merriami* at

Friesenhahn Cave, *Sorex cinereus* and *Chaetodipus merriami* at Schultze Cave in Edwards County. These associations have been termed non-analog because they have no analogs in modern faunas. In many cases the pairs of species now have distributions separated by tens to hundreds of kilometers. These associations have been interpreted as indicating a more equable climate with smaller seasonal differences (HIBBARD, 1960). These associations are not restricted to Central Texas but are found all over North America as well as Australia and other continents (GRAHAM AND LUNDELIUS, 1984; LUNDELIUS, 1989). Although it has been suggested that the associations could be the result of stratigraphic mixing, time averaging or even very rapid climatic shifts in a given area, recent radiocarbon dates have shown that in many instances the dates of bones of non analog pairs of species are too close together for any of these to be credible explanations (STAFFORD et al., 1999).

The end of the Pleistocene was marked by the extinction of many of the large mammals. At the same time a number of the extralimital species disappeared from the Edwards Plateau. *Synaptomys cooperi*, *Sorex pennsylvanicus*, *Tamias striatus*, and *Mustela erminea* have not been found in faunas younger than about 10,000 years BP. The non-analog associations of species also disappeared at this time.

Holocene faunas consist of species making up the modern fauna plus a few Pleistocene holdovers in locally favorable refugia. These are the voles *Microtus pinetorum* and *M. ochrogaster*, the mole *Scalopus aquaticus* and gopher *Geomys bursarius*. The distributions of these species gradually diminished as the climate became drier. The pine vole (*Microtus pinetorum*) persisted into the 1930s near Kerrville (MCCARLEY AND BRADSHAW, 1953). During this time a few new species arrived: ringtailed cat (*Bassariscus astutus*) and rock squirrel (*Ammospermophilus variegates*).

Although most of the cave deposits represent short periods of time, Halls Cave in Kerr County, Texas, has an unusually detailed sequence. It is richly fossiliferous and with 150 radiocarbon dates has no significant hiatuses. It has provided a detailed record of the mammalian fauna over the last 17,000 years (TOOMEY, 1993). Magnetic susceptibility studies have identified several climatic shifts during the period of time represented by these sediments (ELLWOOD AND GOSE, 2006). In addition, stable strontium isotope analyses have provided information on the rate of soil erosion in that area (COOKE ET AL. 2003).

Friesenhahn Cave in Bexar County has produced a rich fauna, unusual in that there were articulated skeletons of the scimitar cat *Homotherium serum* and the long nosed peccary *Mylohyus nasutus*. These specimens provided new information about the osteology of these species. In addition there were a large number of teeth of juvenile mammoths, which has led to speculation that they were the prey of the scimitar cat. If the scimitar cat was responsible, the question arises as to how it was able to kill so many young mammoths. This has led to speculation as to whether the social structure of the mammoth was as effective as that of the modern elephants in protecting their young from predators. (RAWN-SCHATZINGER, 1992).

The growth series of *Homotherium* has provided information on the eruption sequence of the dentition. RAWN-SCHATZINGER (1983) pointed out that the scarcity of older juveniles in the sample indicates that this species was similar to the modern African lion in that those individuals with functional deciduous teeth and with permanent teeth just beginning to erupt had left the cave to hunt with the adults.

5. Conclusions

Caves on the Edwards Plateau contain deposits that have made important contributions to our knowledge of Late Pleistocene and Holocene faunas and environments. They have provided the basic data for the faunal changes taking place over this period of time. Exceptional preservation in a few caves has provided data on the osteology of several species and information bearing on the development and behavior of some. The short time span represented by nearly all of the cave deposits indicates that caves on the Edwards Plateau were not open to the surface for very long periods of time. This indicates that geomorphic processes have been operating to plug the entrances fairly soon after they were opened, which has constrained the accumulation of deposits containing fossil material. Thus the fossil record of this area has to be correlated from numerous localities.

Acknowledgements

I thank Judith Lundelius for editorial assistance and L. Murray and C. George for technical assistance.

References

- COOKE, M.J., L.A. STERN, J.L. BANNER, L.E. MACK, T.W. STAFFORD JR, R.S. TOOMEY III. (2003). Precise timing and rate of massive late Quaternary soil denudation. *Geology* **31**(10),853–856.

- ELLWOOD, B.B. and W.A. GOSE (2006) Heinrich H1 and 8200 yr B.P. climate events recorded in Hall Cave, Texas. *Geology* **34**(9),753–756.
- GRAHAM, R.W. and E.L. LUNDELIUS JR. (1984) Coevolutionary disequilibrium and Pleistocene extinctions. In: *Quaternary Extinctions: A Prehistoric Revolution*, P.S. MARTIN, and R.G. KLEIN, (eds.), Univ. Ariz. Press. Tucson, Arizona, pp 223–249.
- HIBBARD, C.W. (1960) An interpretation of Pliocene and Pleistocene climates in North America. *Michigan Academy of Science, Arts and Letters, 62nd Annual Report*, 1959–1960, 5–30.
- LUNDELIUS, E.L. JR. (1989) The implications of disharmonious assemblages for Pleistocene extinctions. *Journal of Archaeological Science* **16**, 407–417.
- LUNDELIUS, E.L. JR. (2006) Cave site contributions to vertebrate history. *Alcheringa Special Issue* **1**, 195–210.
- MCCARLEY, W.H. and W.N. BRADSHAW (1953) New locality records for some mammals of eastern Texas. *Journal of Mammalogy* **34**, 515–516.
- RAWN-SCHATZINGER, V. (1983) Development and eruption sequence of deciduous and permanent teeth in the saber-tooth cat *Homotherium serum* Cope. *Journal of Vertebrate Paleontology* **3**(1), 49–57.
- RAWN-SCHATZINGER, V. (1992) The scimitar cat, *Homotherium serum* Cope. Osteology, functional morphology and predatory behavior. *Illinois State Museum Reports of Investigations*, No. **47**, 80.
- STAFFORD, T.W. JR, H.A. SEMKEN JR, R.W. GRAHAM, W.F. KLIPPEL, A. MARKOVA, N.G. SMIRNOV, J. SOUTHON (1999) First accelerator mass spectrometry ¹⁴C dates documenting contemporaneity of nonanalog species in Late Pleistocene mammal communities. *Geology* **27**(10), 903–906.
- TAYLOR, A.J. (1982) The mammalian fauna from the mid-Irvingtonian Fyllan Cave local fauna, Travis County, Texas. *M.A. Thesis*, University of Texas, Austin.
- TOOMEY, R. (1993) Late Pleistocene and Holocene faunal and environmental changes at Hall's Cave, Kerr County, Texas. *Dissertation* University of Texas, Austin. 2 vols.
- WINKLER, A.J. and W. GOSE (2003) Mammalian fauna and paleomagnetism of the middle Irvingtonian (early Pleistocene) Fyllan Cave and Kitchen Door localities, Travis County, Texas. In *Ice Age Cave Faunas of North America*, B.W. SCHUBERT, J.I. MEAD, and R.W. GRAHAM (Eds.), Indiana University Press, pp 215–261.

IDENTIFYING PREHISTORIC TRACKWAYS USING STRIDE LENGTHS: BEHAVIORAL INFERENCES FROM JAGUAR CAVE, TENNESSEE

KYLE MCCORMICK

Department of Anthropology, California State University, Chico, California 95929-0400 USA

Besides metric and morphological analysis of foot impressions, foot impressions can be analyzed in context by examining the relationship of foot impressions to one another. In some instances, it is possible to follow the routes taken by prehistoric people; these routes are trackways. The stride length (the distance between two consecutive foot impressions) of these trackways is the preserved evidence of past locomotion patterns. This study identifies trackways from 274 foot impressions in Aborigine Avenue, a cave passage in Jaguar Cave, Tennessee, and infers the behavior that created them. Differences in the locomotion pattern of inbound and outbound trackways and observations of Aborigine Avenue suggest different individuals created inbound and outbound trackways. Also, more variable inbound stride lengths indicate the individuals that produced inbound trackways stopped more often than those who made outbound trackways, which is consistent with exploring. This study suggests that the earliest cave trips by humans in the southeastern United States were exploratory

1. Introduction

Evidence of past human activity comes from many archaeological materials. Archaeological remains often include artifacts (e.g. lithics), biofacts (e.g. animal bones) and features (e.g. building foundations). These materials are the byproduct of human activities and provide archaeologists with evidence of past human behavior. Archaeological knowledge is biased toward human activities that leave durable materials.

Under rare circumstances, however, perishable or ephemeral materials, such as organic remains and foot impressions, preserve in the archaeological record. These trace archaeological forms provide valuable insights to past human activities, such as locomotion patterns. Foot impressions provide information about the evolution of bipedalism, hominid kinetics, population composition, gender- and age-related activity roles, resource exploitation and land use (LEAKEY AND HAY, 1979; SCALES, 2002; ALLEN et al., 2003).

In some instances, it is possible to trace the route of individuals by identifying their trackways. An individual's stride length (the distance between successive foot impressions of a trackway) is influenced by extrinsic and intrinsic variables, different locomotion patterns, such as walking or running, leave variable but predictable distances between foot impressions in a trackway. By understanding how these variables influence the distance between foot impressions, locomotion patterns and behavior can be reconstructed. For example, if a person ran across a flat surface, the trackway has different stride lengths than a

trackway produced by someone walking across an irregular surface.

This study attempts to identify trackways from 274 prehistoric foot impressions in Aborigine Avenue, a cave-passage deep in Jaguar Cave, Tennessee. Radio carbon dates from associated charcoal suggest these impressions date to 4590 ± 75 b.p., making them the earliest example of cave use in the region (WATSON et al., 2005:30, 40). Previous research on these foot impressions suggested that the prehistoric cavers were exploring. WATSON et al. (2005) compared the shape, location and orientation of these foot impressions. Foot impressions nearer the front of the passage are more linearly distributed than those toward the back of the passage (WATSON et al., 2005:35). WATSON et al. (2005) concluded that similar to modern cavers, these prehistoric cavers wandered and explored as they entered the cave passage and made a more direct exit. The present study identifies trackways and reconstructs the locomotion patterns and behavior of these prehistoric cavers to examine this hypothesis.

2. Materials and Methods

This study employs Louise Robbins's and Patty Jo Watson's Jaguar Cave notes and maps curated at the William S. Webb Museum of Anthropology, University of Kentucky, Lexington. Materials used include personal correspondence, field notes and maps of 274 foot impressions from Aborigine Avenue in Jaguar Cave. These foot impressions were drawn on maps at eight survey stations (WATSON et al., 2005:29). Survey stations were established by National Speleological Society members as they explored and mapped

Aborigine Avenue (WATSON et al., 2005:27, 31). Each map was assigned the same number as the survey station (SS) and indicates locations of foot impressions near the SS. These field maps were numbered SS 10, 12, 13, 15, 16, 17, 18, and 22. Foot impressions were documented (mapping, photography and impression casting) on 21 trips by recorders between October 1976 and August 1993 (WATSON, unpublished notes). Each impression was assigned a number, and a Mylar tag with that number was placed in the impression (WATSON, unpublished notes).

Not all areas of Aborigine Avenue had foot impressions and not all areas containing foot impressions were appropriate for step length analysis. Areas with tracks in the same general direction and minimal confounding factors, such as overlapping and partial impressions, were appropriate for analysis. SS 12, 13, 15B, 16A, 16B, and 18 meet these criteria and were examined in the present study. SS 10 had a limited number of foot impressions ($n = 12$) and no trackways were identified from that area. SS 17 and 22 were also problematic for stride length analysis. These SS areas were near Aborigine Avenue's dead-end and had numerous overlapping impressions ($n \geq 52$, $n \geq 50$ for SS 17, and 22, respectively). In many cases, the orientation of the foot impression from these areas, either inbound or outbound, was unclear. Because of these limitations, SS 10, 17, and 22 were excluded from the present study.

To identify trackways of the prehistoric cavers, the results of JASUJA (1993) were used to estimate the most likely next step. Participants in the JASUJA (1993) study (283 Jat Sikh males from India) walked at their preferred speeds with ink-soaked feet across white paper on an even surface. Four to five foot prints, equivalent to three to four stride lengths, were recorded for each individual. This information makes it possible to estimate a location where the next step of a trackway may be located.

Using the average Jat Sikh stride length, analysis of the Jaguar Cave foot impressions was conducted using the following method. Stride length was measured from the field maps. A first foot impression was chosen. This foot impression was conspicuous and near one edge of the SS area, pointing toward the opposite side of the SS area. After this first foot impression was selected, three arcs were drawn around the foot impression, using the heel of the impression as the center of the arc. The middle arc represented the average expected stride length of the prehistoric cavers based on the average Jat Sikh stride length; the shorter and longer radii indicated two standard deviations from this average step length. The next step was expected to be within this

area 95% of the time. Any portion of a foot impression in this area was considered a possible next step.

Next, side of foot (left or right), orientation (inbound or outbound), and size of the foot impression were used to eliminate foot impressions in the defined area. First, foot impressions of the same side or of opposite orientation as the starting foot impression were eliminated. If more than one foot impression remained that were possible next steps, foot impression measurements were examined.

Statistical analysis is performed using SPSS 16.0 and an alpha level of 0.05. Descriptive statistics for inbound and outbound trackways and foot impressions include minimum and maximum lengths, mean length and standard deviations. Independent sample *t*-tests evaluate differences in average stride length and foot length of inbound and outbound trackways and the effect of ceiling height on step length.

3. Results

Using the methods outlined in the previous section, 16 trackways are identified in Aborigine Avenue (Table 1). These trackways consist of 2 to 6 foot impressions per trackway, for a total of 42 impressions. There are eight inbound trackways and eight outbound trackways. On average, inbound trackways have more impressions than outbound trackways, with ten more inbound than outbound impressions. Trackways 12 and 14 contain partial impressions without assigned numbers; these incomplete impressions have a heel, marking stride length measurements. No measurements, however, are possible for partial impressions.

Overall, inbound strides are longer and more variable than outbound strides (Table 3). The average stride length for the total trackway sample is 53.3 ± 10.8 cm (inbound 56.5 ± 11.59 cm and outbound 47.6 ± 6.6 cm; $t = 2.437$, $df = 22.961$, $p = 0.023$; Levene's Test not assuming equal variance). As stride length, inbound foot lengths are longer and more variable than outbound foot lengths (Table 2). The average foot impression length for the overall sample is 24.1 ± 2 cm (inbound 24.7 ± 2.1 cm and outbound 22.9 ± 1.1 cm; $t = 2.287$, $df = 23$, $p = 0.032$). There is no difference, however, from stride lengths between low and high ceiling areas ($t = -.833$, $df = 23$, $p = .413$). These results suggest that the prehistoric cavers used different locomotion patterns entering and exiting the cave passage, and these patterns were not affected by ceiling height. Also, inbound trackways represent taller (at least longer footed) individuals than those who produced outbound trackways ($t = 2.287$, $df = 23$, $p = 0.032$).

Trackway	SS Area	Impression	Foot Length	Ball Width	Heel Width	Side	Direction	Step Length
TW1	12	77	24	8.5	5	L	O	52.1
		78	21	7		R	O	60.5
		75	21	6	5	L	O	
TW2	12	79	24	8		R	O	50.9
		70	23	8	6	L	O	
TW3	12	76	26	7	5	R	O	50.8
		82	22.5	8	5	L	O	
TW4	13	116	24		6	L	I	64.4
		123	24		5.5	R	I	
TW5	13	119	29		7	L	I	72.2
		4	28.5	5.5	8	R	I	
TW6	13	117	23.5		5.5	L	O	41.3
		3	23	5	6	R	O	
TW7	13	118	24	8	6	L	O	40.6
		2	24	6	6	R	O	
TW8	13	108	27		8	R	I	66.2
		8	27.5	8	7	L	I	
TW9	15B	127	20	6.5	5	L	O	41.9
		126	23	7	6	R	O	47.6
		32	23	8	6	L	O	
TW10	15B	103	24	9		L	O	42.9
		100	24	7.5	7	R	O	
TW11	15B	19	28	9	6	L	I	62.1
		23	28	10	7	R	I	
TW12	16A	138	23	7	5.5	L	I	33.8
		147	23	8	5.5	R	I	76.5
		92	25	7.5	6.5	L	I	62.6
		–				R?	I	
		154	19	8.5	5.5	L	I	56.4
TW13	16A	152	25		6	R	I	47.3
		153	25			L	I	
TW14	16B	135	24	7	5	R	I	48.3
		38	25.5	6	6	L	I	54.1
		156	24		7	R	I	68.9
		–				L?	I	45.1
TW15	16B	161	25	8.5	6	R	I	
		39	26	7.5	7	L	I	48.9
TW16	18	158	25	10	7	R	I	
		215	22	8.5	6.5	L	I	49.9
		217	22	8	7	R	I	47.3
		218	22	8.5	6	L	I	

Table 1: Aborigine Avenue, Jaguar Cave trackway descriptive data. Foot impression measurements from WATSON et al. (2005). All measurements are in centimeters.

	N	Mean	Minimum	Maximum	s.d.
Step Length					
Inbound	16	56.5	33.8	76.5	11.59
Outbound	9	47.6	40.6	60.5	6.6
Total	25	53.3	33.8	76.5	10.8
Foot Length					
Inbound	16	24.7	21.5	29	2.1
Outbound	9	22.9	21	24.3	1.1
Total	25	24.1	21	29	2

Table 2: Mean stride and foot lengths of Aborigine Avenue, Jaguar Cave trackways. All measurements are in centimeters.

Cluster Individual	Number of Foot Impressions in Trackways		
	Outbound	Inbound	Total
1	0	3	3
2	0	2	2
3	1	3	4
7	2	0	2
8	2	0	2
9	7	7	14
Total	12	15	27

Table 3: The association of trackways and foot impression clusters.

4. Discussion

There are three possible explanations for differences in inbound and outbound walking patterns. The first explanation is the prehistoric cavers walked faster as they entered Aborigine Avenue than as they exited. The second explanation is the prehistoric cavers walked over a slipperier and more level surface exiting the cave passage than entering. The third explanation is different individuals created the inbound and outbound trackways. These explanations are not mutually exclusive, and a combination of factors may be responsible for differences in walking patterns.

4.1 Speed

If the prehistoric cavers walked faster entering Aborigine Avenue than exiting, this difference in speed suggests that they were not exploring. Longer inbound stride lengths indicate a faster walking speed; however, as walking speed increases, stride length increases and become less variable (CAVANAGH AND KRAM, 1989; JASUJA et al., 1997; JORDAN et al., 2007). If the prehistoric cavers walked faster entering Aborigine Avenue, then inbound trackways should be longer and less variable than outbound. Inbound step lengths, however, are longer but more variable than outbound step lengths. Thus, walking patterns are

inconsistent with faster inbound than outbound walking.

4.2 Surface properties

Pliable surfaces, where foot impressions form, produce less friction between the foot and surface than irregular surfaces. Individuals change their walking pattern to produce more friction by increasing the angle of contact between the foot and surface, which decreases stride length (COOPER et al., 2007). If outbound trackways were created on a slipperier surface than inbound trackways, this walking adjustment could explain the shorter outbound stride lengths. On the other hand, if inbound and outbound trackways were created on similar surface substrates, walking pattern differences could result from adjustments to an uneven surface when the prehistoric cavers entered the passage.

When terrain is uneven, longer stride length increases step duration and gives individuals more time to decide where to place the foot (MENZ et al., 2003). Longer and more variable stride lengths are consistent with walking pattern adjustments to an uneven surface and is the walking pattern observed in inbound trackways. If the prehistoric cavers were exploring Aborigine Avenue as they entered, they were unfamiliar with the cave passage and more likely to encounter irregular terrain than when they exited. Observations of the surface properties of Aborigine Avenue and the location of trackways in Aborigine Avenue can further examine these explanations.

Observations of the modern surface properties of Aborigine Avenue indicate that the surface substrate and level of inbound and outbound trackways is similar. In most cases, inbound and outbound trackways are located close to each other. And the surface consistency of Aborigine Avenue only shows marked differences between the front and back of the passage; the surface in the front of the passage is dryer than the back. The middle of the passage, where most trackways

are located, has a uniform surface level and consistency.

4.3 Different individuals

Longer inbound than outbound foot impressions suggests that different individuals produced inbound and outbound trackways. This inference is supported by comparisons of inbound and outbound trackways with cluster individuals by WATSON et al. (2005). Based on measurements and qualitative observations of the foot impressions, they believed nine people created the Jaguar Cave foot impressions (ROBBINS et al., 1981). Using this estimation, foot impressions were assigned to one of nine clusters using discriminant function analysis of foot length, ball width, and heel width measurements (WATSON et al., 2005:35-36). These clusters are compared to foot impressions from trackways to evaluate whether inbound and outbound trackways represent different individuals.

Six of nine cluster individuals are represented in trackways (Table 3). Cluster individuals 1 and 2 have only inbound foot impressions and a majority of cluster individual 3's foot impressions (3 out of 4) are also inbound. Cluster individuals 7 and 8 have only outbound foot impressions. Cluster individual 9, however, has an equal distribution of inbound and outbound foot impressions (7 inbound, 7 outbound). With the exception of cluster individual 9, cluster individuals are separated by inbound and outbound trackways, supporting the inference that different individuals produced inbound and outbound trackways.

5. Summary and Conclusions

Differences in locomotion patterns between inbound and outbound trackways in Aborigine Avenue could indicate different individuals produced inbound and outbound trackways. Different average foot impression length and comparisons of trackway foot impressions with cluster groups support this suggestion. Inbound foot impressions are longer than outbound and cluster individuals 1 and 2 are only represented by inbound trackways and cluster individuals 7 and 8 are only represented by outbound trackways.

Other possibilities for walking pattern differences, such as differences in surface properties or speed of walking, are not supported by the contextual evidence of Aborigine Avenue or trackway locomotion patterns. The relative uniformity of surface consistency and grade, and the close proximity of inbound and outbound trackways refute the possibility that walking pattern differences result from differences in surface properties. Despite longer inbound stride lengths,

it is unlikely the prehistoric cavers walked faster entering the cave passage than exiting. Stride length is less variable as walking speed increases, and inbound walking patterns are more variable than outbound. The more variable inbound stride lengths are consistent with repeated starts and stops during walking, suggesting exploration.

Also, inbound foot impressions were subject to damage by the foot impressions of the exiting prehistoric cavers, which should result in fewer inbound than outbound foot impressions (WATSON et al., 2005). In most cases, inbound and outbound trackways are located close to each other, suggesting outbound foot impressions probably destroyed some inbound foot impressions. Despite being subject to damage by outbound foot impressions, however, there are 27 more inbound than outbound foot impressions in Aborigine Avenue (150 inbound and 123 outbound; WATSON et al., 2005:35). The greater number of inbound than outbound foot impressions and greater variability in inbound stride lengths suggests the prehistoric cavers took more steps entering the passage, and they started and stopped walking more often when entering the passage. This behavior is consistent with exploring. The present study supports the hypothesis of WATSON et al. (2005) that the prehistoric cavers explored entering Aborigine Avenue and made a direct and expedient exit from the passage, which suggests the earliest cave trips in the region were exploratory.

Acknowledgments

I thank George Crothers for his hospitality, those at the William S. Webb Museum of Anthropology at the University of Kentucky, Lexington, for access to the Jaguar Cave field maps and other materials, Patty Jo Watson for her years of dedicated work on the Jaguar Cave foot impressions and her detailed field notes, and Kristin Bobo and the Southeastern Cave Conservancy for access to study the Jaguar Cave foot impressions *in situ*. Also, special thanks to P. Willey and Eric Bartelink, their tutelage cannot be underestimated.

References

- ALLEN, J.R.L., M.G. BELL and R.R.L. SCALES (2003) Animal and human footprint-tracks in archaeology: description and significance. *Archaeology in the Severn Estuary* 14:55-68.
- CAVANAGH, P.R. and R. KRAM (1989) Stride length in distance running: velocity, body dimensions and added mass effects. *Medicine and Science in Sports and Exercise* 21(4):467-479.

- COOPER, R.C., et al. (2007) Step length and required friction in walking. *Gait and Posture* doi:10.1016/j.gaitpost.2007.07.004.
- JASUJA, O.P., S. HARBHAJANAND, and K. ANUPAMA (1997) Estimation of stature from stride length while walking fast. *Forensic Science International* 86:181–186.
- JORDAN, K., J.H. CHALLIS, and K.M. NEWELL (2007) Walking speed influences on gait cycle variability. *Gait and Posture* 26:128–134.
- LEAKEY and HAY (1979) Pliocene Footprints in the Laetoli Beds at Laetoli, Northern Tanzania. *Nature* 278(5702):317–323.
- MENZ, H.B., S.R. LORDAN, and R.C. FITZPATRICK (2003) Acceleration patterns of the head and pelvis when walking on level and irregular surfaces. *Gait and Posture* 18:35–46.
- ROBBINS, L.M., R.C. WILSON, and P.J. WATSON (1981) Paleontology and Archeology of Jaguar Cave, Tennessee. *Proceedings of the 8th International Congress of Speleology Bowling Green.*, pp 377–380.
- SCALES, R.R.L. (2002) Footprint-tracks at Goldcliff East. *Archaeology of Severn Estuary* 13:31–35.
- WATSON, P.J., et al. (2005) Prehistoric footprints in Jaguar Cave, Tennessee. *Journal of Field Archaeology* 30(1):25–43.

THE SIGNIFICANCE OF CAVE BEARS FOR PASSAGE MORPHOLOGY

LUKAS PLAN¹, DORIS DÖPPES², THOMAS WAGNER³

¹Natural History Museum Vienna, Department for karst and caves; Museumsplatz 1/10, A-1060 Wien, Austria, lukas.plan@nhm-wien.ac.at

²Austrian Academy of Sciences, "Biologische Station Lunz" & Institute of Palaeontology, Althanstraße 14, A-1090 Wien, Austria
doris.doeppes@univie.ac.at

³Department for Earth Sciences, University of Graz, Universitätsplatz 2/II, A-8010 Graz, Austria, thomas.wagner@uni-graz.at

Abstract

Cave walls polished by passing cave bears (so called Bärenschliffe) are known from some dozen caves in Europe that were populated by cave bears in the Middle and Upper Pleistocene. Bärenschliffe are rounded and polished parts of cave walls and boulders originating from the passing cave bears, rubbing their fur along the walls. They mainly occur on edges that project into the passages but also on straight walls. Bärenschliffe were first noticed and interpreted as animal traces in 1806 from Drachenhöhle near Mixnitz (Styria, Austria), where they are very pronounced. However for some caves it is doubted that these features are traces of cave bears.

The aim of this presentation is to show that the features are Bärenschliffe by excluding any other geological or anthropogenic process that could have caused these features. Further we want to point out the significance of cave bear presence for the mesomorphology of that caves. We found that in some caves like Drachenhöhle, Arzberghöhle, and Peggauerwandhöhle, many boulders and often whole sections of cave walls (often several square meters) were reshaped due to passing by cave bears. To constrain the age of the Bärenschliffe a stalagmite that has grown on such a polished surface is being dated using the U/Th-disequilibrium method.

A NEW TOOL-TYPE FROM THE UPPER STRATIGRAPHIC LAYERS OF PETRALONA CAVE

DR NICKOS A. POULIANOS

Ministry of Culture, Ephorate of Palaeoanthropology-Spelaology, Ardittou 34b, Athens 11636, Anthropological Association of Greece, Daphnomili 7, Athens 11471 (e-mail: aee@otenet.gr)

Among the various hand-axes, cleavers, scrapers, points etc from Petralona Cave (Northern Greece, Macedonia, Chalcidice) a new tool type is described, which was unearthed in the upper stratigraphic layers. Its code number is B-103 and concerns a very heavy bauxite rock. It weights 3708 gm and the volume reaches 1090 cc. Compared to the other Petralona Palaeolithic findings, it may be considered as highly elaborated, since all of its surfaces are worked. One of the edges (supposedly the lower one) is transversally and bifacially flaked, further retouched as well. As a result a huge hacking-cutting edge of 120 mm is formed. Once the flaking is transversal and not parallel to the edge, the diagnosis of a “super-cleaver” must be excluded. Morphologically, it is reminiscent of a huge transverse scraper, a classification that because of its weight and dimensions must again be rejected (such a big tool type has not being previously recorded). Hyper-axe is the proposed term for the new tool type.

1. Introduction

Petralona cave provided, within a rich geospelaological context, a series of findings that concern Palaeoanthropology, Palaeolithic, as well as Palaeontology, Palaeobotany. Over the last half a century the fossil collections are enlarged, yielding to more and more clear chronological evidence. Despite several controversies met in the scientific bibliography regarding Petralona cave stratigraphy (layers 1–33), the most probable and updated age of about 0.55–0.8 Ma is considered. This is concordant to the more recent studies of palaeontological fossils, absolute datings, as well as bone and stone tools of the Lower Paleolithic (cf. A. Poulianos, 1971, 1982, N. Poulianos, 1995).

The data of the Anthropological Association of Greece are extracted under very harsh conditions, greatly hesitating the co-respective reports. Thus an extensive account, but still preliminary, of the Lower Palaeolithic stone tools (almost one 1000) from the Petralona stratigraphic sequence became possible for publication only lately (N. Poulianos, 2008).

It worth also to refer that the raw material used for tool making in Petralona mainly concerns bauxite and quartz, which do not belong to the cave geological context. Therefore, prehistoric humans transported these stone materials into the cavern from the vicinities (~2–3 km far). Only the few elaborated limestones, fallen and/or detached from the cave walls, may belong (besides stalagmites) to rocks selected from the inner cave spaces too. On the other hand just four flint items were discovered during the excavations. Flint is met almost 10–15 km away, indicating

that Petralona Archanthropuses did not usually “travel” far around the cave region, not excluding however that some groups left the cave without returning back (due p. ex. to overpopulation, adventure etc).

2. Description of the Finding and the New Tool Type

B - 103 (2nd code number: T.B. 1087) is a Lower Palaeolithic brown bauxite stone tool found the August 10th 1977, in the 2nd layer of Section B (see also Veni et al, 2009 in this volume). It regards an angled trapezoid large stone, which has a weight of 3708 grams and a volume of 1090 cc, leading to a comparatively high specific gravity of 3.4.(Fig. 1).

The face bearing the code number is defined as “outer”, since the 10 main (deeper) large scars are made there, while the opposite face is a little less elaborated presenting 7 main scars. Those towards the “lower” part of the tool (3 main on each face) are flaked longitudinally to the artifact’s axis and form the working edge. The latter is also further retouched by 18 semi-abrupt retouchings (12 short and 6 long), equally distributed on each face, some of which may be also due to the labor of the heavy tool by the inhabitants of Petralona cave circa 0.55 Ma ago.

Moreover the “outer” face possesses other 15 shallower scars, of which eight are intercepting to the “right,” 2 are also large to the “left,” while there are other 5 smaller. The “handle” (opposite to the working edge) has 4 scars, while the “inner” face other seven shallow and one deep made by a triple blow, perhaps in a try to cut off a stone projection.

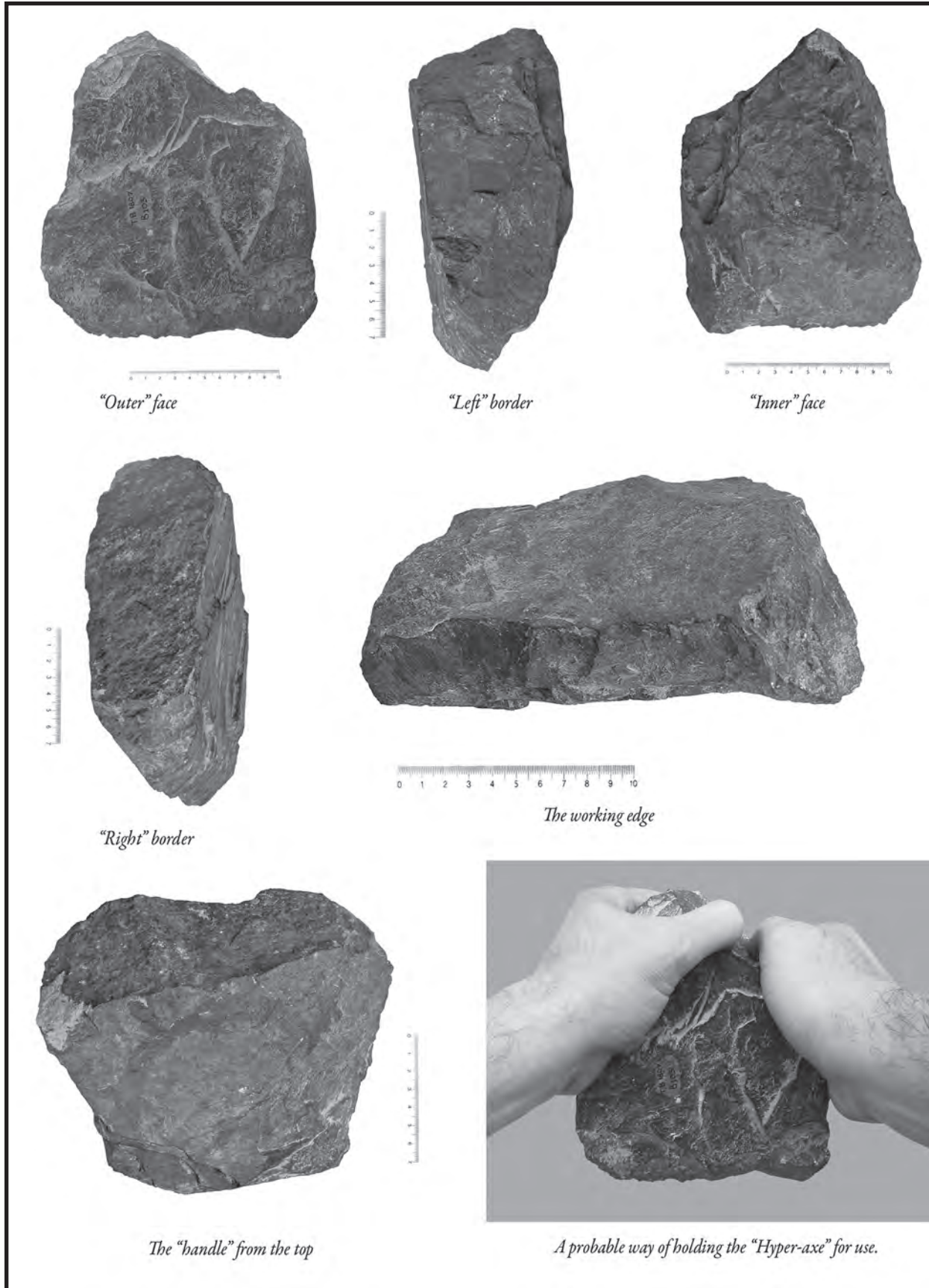

Figure 1: Collage of photographs showing various aspects of the artifact B-103.

Therefore a total of 43 scars are counted all around (or 45 if the triple one is not counted only as 1). Two of the central scars on both faces (more evident that on the “inner” one) are considered as “finger-sockets”, created to facilitate the handling of the tool.

Both of its faces, comparatively to the other Petralona stone tools, appear intensively elaborated, in a similar way however as other two cores: X-7b (made on quartz) and П-3 (made on flint) from Section E and almost from the same stratigraphic upper layers ½. The backing degree of the working edge is almost the 3rd one, in a scale from 1 (fresh) to 5 (totally blunt). Direct percussion of Lower Petralona Palaeolithic technology (clearly pre-“Achellean”) was evidently attributed, reconfirming the chronology of the object. The flaked surfaces, especially the larger scars, most probably indicate the use of the stone item also as a core.

Other dimensions of the bauxite tool regard (a) the total diagonal length: 197 mm, (b) the functional length (along to its morphological axis): 190 mm, (c) the maximum width: 150 mm, (d) the width at the middle: 145 mm, and (e) the maximum thickness: 73 mm.

As applied to all excavated Petralona cave findings, also the traces of the attached sediment are not removed from B-103 (see below reported photos), enabling thus eventual future verifications, comparisons and lab analyses. To the “left” upper corner of the finding sinter of the 1st stalagmitic layer is preserved, perhaps indicating that this corner was not entirely covered by the 2nd layer, and that it was somehow banking on (a stone, cave wall or other object). Attention must be drawn to that the chronology of the stone tool in description might not be confused with the age of the younger stalagmitic cover, and that the age of the 2nd layer must be attributed to it.

The above-mentioned working edge presents a huge hacking-cutting edge of 120 mm and a slight notch to the “left”. Once its flaking is transversal and not parallel to the edge, the diagnosis of a “Super-cleaver” must be excluded. Morphologically it resembles an enormous transverse scraper, classification that because of its weight and dimensions must again be rejected. Since such a big tool type has not been previously recorded, “Hyper-axe” is the proposed term for the new tool type.

Taking into consideration the great weight of the artifact, its probable use may be considered for the disjunction of articulations from various medium or big animal games (p. ex. spinal column, pelvis, femur etc), as well as cutting

of meat pieces from their bones. Limestone’s analogous use must be considered less probable for nutrition reasons, because it shatters easy even in minuscule pieces, which once remaining inside the meat would complicate its mastication. Another probable use may concern crashing big bones and/or their longitudinal fragmentation (by adequate cuts) in order to produce long bone tools (cf. above). Under these circumstances it could also be named as “Crasher,” but apparently the term “Hyper-axe” remains more appropriate. Probably it was held by both hands (as indicated in photo B-103 f), otherwise by only one hand but from a very strong individual.

A less probable use may regard the cut of tree branches or small trunks. The many traces of fire discovered during the excavations in various cave layers, could give reason to the elaboration of an analogous artifact. At the same time however the difficult transportation and moiling construction of such a tool, for works that could be easier done in an other way, weakens this hypothesis, since the cut of branches may be achieved by simple detach from the tree trunks and/or by the aid of acute rocks not elaborated, such as big lime stones that are abundant all over the region.

Anyway, according to the above, although the finding is unique and not repeated, there is no doubt that it is dealt with a huge axe. Perhaps the use of similar tools, when further backing (blunted), was limited only to that of fragmented cores. On the contrary B – 103 is preserved because it was still functional when deposited in the 2nd layer, a little before the cave has been sealed by sediments. Consequently, since further elaboration of similar artifacts as cores, for debouching flakes and producing more tools, is the most probable case, the discovery of “Hyper-axes” becomes very rare in Petralona cave or elsewhere. There is also the probability that it is dealt with an extraordinary individual capacity of producing new technological achievements, observed in other Petralona Palaeolithic findings too, always within the time span of 0.55–0.8 Ma.

Due to the previously referred probable domestic uses of the B – 103 and its weight, it is deduced that the finding, once transported inside the cave (even heavier), was not further removed from the inhabited cavern or its vicinities. For the same reasons the use of the “Hyper-axe” as a hunting tool may be disregarded.

Description of the new tool-type: Elaboration on big stones, with a weight more than 3 (and/or 2,5) kilograms and a volume more than 1000 (and/or 750) cc, on which a huge axing-cutting working edge is flaked bifacially and

longitudinally (to the axis), with a length that overpasses 100 (and/or 70) mm.

References

- Poulianos A.N. (1971) - Petralona: A Middle Pleistocene Cave in Greece. *Archaeology*, 24: 6–11.
- Poulianos A.N. (1982) - The Cave of the Petralonian *Archanthropinae*. Athens – Petralona, p 80.
- Poulianos N.A. (1995) - La grotta e l'uomo di Petralona. Ed. B. Chiarelli, Istituto di Antropologia di Firenze, p 127.
- Poulianos N.A. (2008) - Petralona Palaeolithicum – The eldest technology of modern humans, p 370. Athens.
- Veni, G., N.A. Poulianos, M. Golobovič-Deligianni, and A.N. Poulianos (2009) Preliminary hydrogeologic survey of Petralona Cave, Chalkidiki, Greece. Proceedings of the 15th International Congress of Speleology.

COMBINED NEW PALEOCLIMATOLOGIC AND CHRONOLOGIC EVIDENCE FROM PETRALONA CAVE

NICKOS POULLANOS¹, ATHANASIOS KOUTAVAS^{2,3}, XIANFENG WANG³, LARRY EDWARDS⁴
and ARIS POULLANOS⁵

¹Ministry of Culture, Ephorate of Palaeoanthropology-Spelaology, Arditou 34b, Athens 11636, Anthropological Association of Greece, Daphnomili 7, Athens 11471, Greece, aee@otenet.gr

²College of Staten Island, City University of New York, Staten Island, NY 10314, USA, koutavas@mail.csi.cuny.edu

³Lamont-Doherty Earth Observatory of Columbia University, Palisades, NY 10694, USA

⁴Department of Geology and Geophysics, University of Minnesota, Minneapolis, MN 55455, USA

⁵Anthropological Museum, Petralona 63080, Khalkidhiki, Greece aee@otenet.gr

Extended Abstract

The Petralona cave in northern Greece was discovered 50 years ago, in May of 1959. The paleoclimatologic and chronologic study of the cave sediments and findings has been advanced over the past half century through many scientific publications, often quite controversial. Initial age estimates of ~50,000 years were in 1968 corrected (by 1000% or more) toward much older dates. Currently, the debate is internationally oriented around two main axes. One indicates ages of about 0.3–0.5 Ma while the other 0.6–0.8 Ma. Taking into consideration previous data and the importance of paleoclimatic evidence for the understanding of present-day climatic and environmental conditions, this paper presents

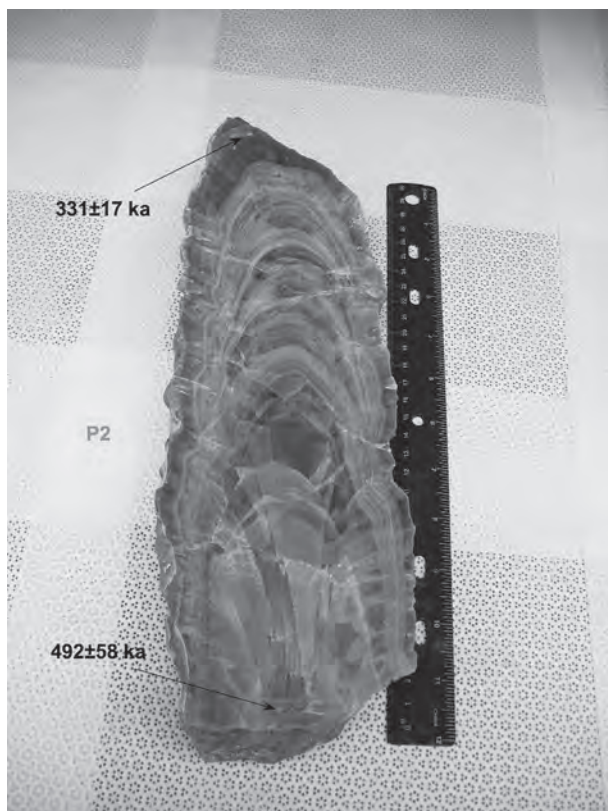

Figure 1: Transverse section of surface stalagmite sample dated from the first layer of the Petralona Cave stratigraphy. Discovered 50 years ago, archaeological remains in Petralona Cave were thought to be 50,000 years old, however, U/Th series dating has significantly pushed back the age of human use. This approximately 30-cm long segment of stalagmite

preliminary new results of relevance to the issue. The results are based on new U/Th dating and oxygen isotopic analyses of three surface stalagmitic samples (from the 1st layer of the Petralona stratigraphic series) (Fig. 1). The sample ages range from 235 to 500 thousand years ago (ka) and indicate significant differences in growth rates likely corresponding to different hydrologic and climatic conditions. Highest growth rates (approximately 3 cm/ka) are observed in two samples that grew between 235–246 ka, and 416–420 ka, most likely corresponding to warm interglacial stages 7 and 11. An oxygen isotopic shift of 3 per mil in the latter sample is consistent with the climatic transition over termination IV (stage 11–12 transition). The results support earlier evidence for major climatic changes in the region, that emerged through the stratigraphic studies and excavating activities of the Anthropological Association of Greece. Further details of the paleoenvironmental evolution and the oscillations of warm and cold periods from Petralona speleothems are in progress for the future.

TEXAS CAVES; TEXAS OSSUARIES

RON RALPH

*Registered Professional Archeologist
13101 Wild Turkey Drive, Manchaca, TX 78652*

Human origins are viewable through caves; our time-encapsulated windows into the past, where life is often frozen in time. The bones and associated artifacts speak to us when recovered from open locations, rock shelters and shallow sinkholes, vertical shafts or caves. A review of human burial practices through the years will show us that variation. The study of human burials is important to mankind in general and because cavers are often at the point of discovery, they should be specifically aware of the potential for burials in caves.

Vertical shafts are the focus of this paper for several reasons. Increasingly, caves are being both discovered and destroyed in the Texas Hill Country due to population increases and urban development. Vertical shaft caverns present a kind of site formation not found in open sites, shelters and crevice burials by offering less chance for subsequent human disturbance. Central Texas shaft burials appear to be more common than elsewhere in Texas although this may be an artifact of more intensive investigations by professionals, cavers and avocational archeologists.

Data substantiates the premise that ossuaries are often the burial location of choice for prehistoric people while dating techniques indicate the practice continued for thousands of years. There are three possible contexts for human burial in Central Texas caves; they have either been placed in caves with care, dropped in from above when the walls are not climbable, or washed in from above or below via water or colluvial slope transport. Of importance to cavers is the fact that any vertical shaft excavation has the potential to produce human remains.

1. Introduction

Human burials offer a cultural-time continuum of grave goods, environmental conditions and the bones themselves – bones that tell many tales when studied closely by the archeologist. These moments in time are found throughout the world in today's cemeteries. These sites have much to tell us about the people who lived and died on this ancient landscape, for as Democritus said over 2,000 years ago, "The secrets of nature lie hidden in certain deep mines and caves." The nomadic hunters and gatherers of Texas often chose caves and sinkholes as ossuaries for burying their dead. Rock shelters, earth cracks, crevices or other natural openings often used for burials will not be discussed because these features are ubiquitous on the landscape and well represented in the literature. Rather, we will explore the rather small set of Texas true caves and sinkholes used as ossuaries and how cavers can assist scientists to learn about ancient people.

Prehistoric burial patterns in North America comprise two data sets: those carefully placed in open locations, rock shelters and shallow sinkholes (primary burials), and those simply dropped into vertical shafts or caves (secondary

burials). Open sites, such as the Wilson-Leonard site, in Williamson County, can reveal very ancient and significant remains (COLLINS et al., 1993). Isolated burials in sinkholes and caves are important because they show the range of distribution or extent of cultural traits. Examples to these kinds of sites are 41KY25 (Leona Ranch Cave) and 41BX1068 (LAG Cave) in Government Canyon State Park. Sorcerers Cave (41TE70) in Terrell County is a good example of a vertical cave with human remains that may have not been used as a burial cave, but is rather an example of a washed-in skeleton or more likely a disturbed secondary burial (i.e. bundle burial), where disarticulated bones are placed or tossed into a cave, then disturbed further by human and animal visitors. Granado Cave in Culbertson County and the Bering Sinkhole (41KR241) in Kerr County indicate primary interments in true sinkholes. Other artifacts and paleontological remains make these caves unique among archeological sites. At Seminole Canyon State Historical Park in Val Verde County, rock shelter excavation reveals preserved hearths, sleeping areas, latrines, and burials carefully placed against the back wall. Faded but monumental rock art adorns the same walls of many shelters while a separate sepulcher across the canyon

(Seminole Sink) served as the ossuary for 22 burials placed there over a 5,000-year span. Seminole Sink (41VV620), in Val Verde County, is an example of a vertical shaft burial site where human remains were not arranged for burial but rather dropped into an open hole. Because remains have not been disturbed except by rodents or other introduced critters, burials are often more complete and the bones can often tell a more complete story than ones found in open sites or in disturbed shelters.

Vertical shaft ossuaries are very rare on the archeological landscape. Vertical shafts are important because more caves are being both discovered and destroyed in the Texas Hill Country due to population increases and development. Sinkholes and vertical shaft caverns present a kind of site formation not found in shelters and crevice burials. They offer obviously intentional placements and less chance for human disturbance than other burial locations although wetter conditions in Central Texas caves can produce problems in recovery, identification and interpretation. And last, shaft burials appear to be more common in the central part than elsewhere in Texas, although this may be an artifact of more intensive investigations by cavers and archeologists.

2. Data

Presented here are examples of true caves that have been recorded as ossuaries. They include horizontal caves, both inclined and with water, vertical caves and shafts where the walls would have been un-climbable for prehistoric peoples and sinkholes where relatively gentle sloping sides and loose soil could be used for grave covering. From these sites, archeologists and cavers have recovered from a few teeth to multiple burials. Many have produced grave goods although most have not. Dating techniques indicate prehistoric people used Texas caves for several thousand years.

41BN18, Skull Cap Cave, is a bridged sinkhole leading into a horizontal passage in the Hill Country State Natural Area, a state-owned property in Bandera and Medina Counties. Texas Parks and Wildlife (RALPH, 1997:101; RALPH, 1996:164) recovered a portion of a human cranium during initial exploration in 1977. No further work has been accomplished to date.

41BN33, the Rainey Site, is a sinkhole excavated by the Texas Highway Department prior to construction of a Farm to Market road in Bandera County (HENDERSON, 2001). The site produced stratified occupational debris and four human teeth. While not exactly a burial cave, the site is in an inhabited sinkhole that did produce human remains.

41BX26, Hitzfelder Cave (COLLINS, 1970) or Hitzfelder's Bone Hole (GIVENS, 1968), has produced up to 50 human burials including 3 semi-articulated skeletons and 27 disturbed individuals (MNI) from the bottom of the vertical entrance drop. Artifacts including several Archaic-age dart points (Frio, Pedernales and Marshall/Lange) plus a radiocarbon date of AD 1000 indicate use as an ossuary over several thousand years. Poor recovery techniques make detailed conclusions problematic.

41BX985, Loftin Sinkhole, is a vertical shaft cave with three passages, two of which produced human bone according to the Texas Archeological Research Laboratory (TARL) records. The cave had been filled with soil and small stone to within 2 meters of the ground surface. Three disarticulated burials were removed from the cave. All bone material was recovered from the first 4 meters of deposit where excavation ceased. The cave was relocated and re-documented by SWCA, Inc.

41BX1068, LAG Cave, is located in Government Canyon State Park west of San Antonio near Helotes. Lubbock Area Grotto members, as part of an attempt to open vertical sinkholes, were digging the cave when bone was discovered. As soon as it was determined human remains were present, excavation ceased and the site capped to prevent further intrusion into the fragile floor. TARL records do not indicate how many individuals are present or if artifacts are present.

41BX1207 is a sinkhole burial site in Government Canyon found by cavers on karst survey. Several long bone fragments, a pelvis fragment and several teeth were recovered from the upper 10 centimeters of fill. After enough bone was removed to indicate the skeleton was not articulated and there were no obvious grave goods, the bones were reburied and soil was placed to stabilize the karst feature. The burial(s) are now preserved in place according to TARL records.

Tin Pot Cave is located within the confines of 41BX1017 (KIBLER, 2002). Excavation of this sinkhole yielded a small amount of modern historic debris and faunal remains that were limited to the surface. Once excavation of the floor began, a human femur and a skull were uncovered; no artifacts were noted in association. All material was returned and reburied.

41BX1251, Ponytail Pit, is a small hole in the center of a 3-m by 4-m catchment area. Surrounding the pit is a surface artifact scatter measuring 225 by 100 meters. This surface is littered with chert cobbles, cores, flakes and a thick

biface fragment. Temporal diagnostics were not recovered. Excavation at this Bexar County site revealed human bone fragments including skull fragments, a possible left humerus fragment and several teeth. The human material appeared disarticulated in a loose soil and rock matrix. Once the bone material was identified, everything was returned to the site and reburied in the pit. Sites BX1251, 1468 1470, 1471 and CM217 are all located on Camp Bullis north of San Antonio (VENI, 2008).

41BX1468, Charleys Cute Little Hole, produced cultural material and a human mandible along with recent historic trash. The vertical sink was being excavated to explore for new passageways when the human mandible was discovered at a depth of 40 centimeters. Once the human bone was identified, everything was replaced and the excavation abandoned.

41BX1470, Flachs Cave, is a small fissure with a 6-meter deep opening to an intermittent stream passage. Several fragments of a human vertebra were collected along with Pleistocene bone material suggesting a prehistoric age. It is not clear if the bones were in primary deposition of if they had somehow washed in from upstream via an older entrance.

41BX1471, Boneyard Pit, is described as a series of five pits or vertical shafts, one of which produced a human tooth. The tooth and other bone is considered transport and does not represent a primary deposit.

41CU8, Granado Cave is located in the Rustler Hills of northern Culberson County. HAMILTON (2001) reports on multiple burials with associated grave goods from his excavations in the late 1970s.

41CU626, ELCOR Burial Cave produced seven skulls but no mandibles or post cranial remains. SKINNER et al., (1980) notes the bone was found on the talus slope below the 10-meter entrance and was obviously dropped into the cave.

41CM217, Camp Bullis Bat Cave, produced one human bone according to the graduate assistant sorting fauna from an environmental study. The site remains problematical.

41CV1165, Fern Cave, is one of several small sinks or caves at Fort Hood in Coryell County. This one produced an articulated skeleton according to the researchers (REDDELL, 2008; TREIRWEILER, 1994). The burial consisted of "two bones aside each other" about 78

centimeters below the original cave floor associated with a few prehistoric artifacts.

41ED22, Green Cave, is a vertical shaft that produced one disarticulated human burial and artifacts probably washed in from an adjacent burned rock midden. A Perdiz arrow point dates the burial to the Late Prehistoric. The cave is large and home to millions of bats. The excavation of this state park property was very limited (CARPENTER et al., 1996).

41KE91, Ranzau Sinkhole, produced one male, one female or adolescent and one child burial. A Scallorn arrow point dates the sinkhole to the Late Prehistoric. The informant as a young boy dug up the burials on his grandfather's property according to Turpin's site form dated 1985 and recorded at TARL.

41KM140, Stiver Ranch Burial Cave, was opened by cavers in an attempt to find going passage. The remains of four burials were found on the floor of the opened cave and taken to the landowner. A South Texas Archeological Association field school excavation of the cave was reported in a Masters thesis (ALVAREZ, 2005) where the bone material from 11 burials was analyzed. A final report on the investigations is still pending.

41KR241, the Bering Sinkhole, was professionally excavated and produced at least 62 human burials in a stratified context. The wealth of artifacts, preserved faunal specimens, radiocarbon dates and meticulous analysis makes this the model for cave excavation in the state of Texas. The burials span the Archaic Period and indicate a 5,500-year continuum as an ossuary (BEMENT, 1994).

41KY25, Leona Ranch Cave, produced at least one burial and a shell ornament. The 3-meter diameter opening led to a crawlway north. Material may be at Texas A&M according to the site survey form recorded by Turpin at TARL.

41ME30, Weynands Cave, was first noted by Bob Benfer and John Greer in the early 1960s and later recorded by Turpin and Bement. Human skeletal material, 3 dart points, 1 bone awl, and one lump of ocher were recovered from the site. Two sinkholes are present; the hole on top of the hill and then east about 50 meters produced three burials dug out by the landowner's relatives. One male (late 20s to 30s) was under a ledge of the west opening and two females were under the roof back from the north opening. A burned rock midden is located near the upper sinkhole.

41PP349, Hills Gate Cave was a recent excavation run jointly by cavers and the Tarrant County Archeological Society (FRALIA, 2000:8) One extended burial was recovered from a narrow fissure north of the main pit excavation. All excavated fill was being processed as potential bone producing matrix. MOSELEY (2008, personal communication) indicates cranial material forms the bulk of the human assemblage but no report is forthcoming. Animal bone is also present.

41TE170, Sorcerers Cave, is well known to cavers as the third deepest cave in Texas. According to explorers (STEELE, et al., 1984) one burial was found in the bank of the river in the lowest part of the cave. The remains are assumed to have washed in. Faunal remains, including a large cat, have also been found along with some interesting artifacts (PREWITT, 1981) found in the upper levels of the cave. The presence of a stratified midden is unlikely anywhere in the cave.

41UV4, Mason Ranch Burial Cave, is a vertical shaft cave with ledges containing interments (BENFER and BENFER, 1962). The not climbable cave contained between 20 and 25 burials, many placed carefully in small niches or ledges, the very similar to the Bering Sinkhole ossuary. Some elaborate ladder or scaffold system must have been employed to reach the 31-foot level, or greater, of the cave unless these lower burials were simply thrown in at an earlier time. Archaic dart points indicate an age range of 2,000 B.C. to 4,000 B.C. for the site.

41UV126, Aldine Cave produced at least two burials according to the site survey form. The sinkhole leads into a beautifully decorated cave with human bone on the floor. Dibble recorded the cave initially at TARL in 1973 followed by a revisit by Turpin and Bement in 1984.

41UV127, Briscoe Bone Cave in Uvalde County, has also produced two burials based on scanty data (Texas Speleological Survey records). The cave was visited by Russell and Reddell in 1964 and was only recently recorded at TARL.

41VV342, Snake Buster Sink, is a vertical entrance cave with a flat floored room of 78 square meters. It was entered and first recorded by Parsons and Remington in 1967 and revisited by Turpin and Bement in 1985 (TARL records). Human bone was noted on the talus pile below the entrance (PARSONS, 1967) but no excavation has been attempted. The site is similar geologically to Seminole Sink (below).

41UV356, the Del Duca Shaft Cave, was reported to TARL by Tom Hester as a vertical shaft burial pit that containing six individuals including two adult females, one adult male, two indeterminate adults and one infant. Although many artifacts were reported to the investigators, only two Busycon sp. gorgets were loaned for study. These artifacts are more often found along the Texas Coast and in East Texas than in a cave in west Texas. The owners sold the property and left archeologists with nothing more than a general location near Chalk Bluff.

41VV620, Seminole Sink, is a vertical entrance cave located in Seminole Canyon State Historical Park. The cave was excavated by the University of Texas at Austin in 1980 and produced 22 individuals. Although lacking many artifacts, the bone material produced a wealth of information for this Early Archaic population. Dating is based on the recovery of an early corner-notched dart point and several radiocarbon dates (TURPIN and BEMENT, 1988).

41WM268, Heireman Cave, is known only from the site survey form at the Texas Archeological Research Laboratory. The site consists of at least 5 sinkholes in limestone. The owner removed dark, clayey fill from two of the holes and, after spreading the fill on his lawn, began finding human bone fragments, projectile points, and flint debitage. The artifacts indicate an Archaic Period age. Three of the holes remain relatively undisturbed and the presence of more secondary burials is assumed (TURPIN and BEMENT, 1988:9).

Backhole Cave is on Camp Bullis in Bexar County. It is situated in a creek bed where it catches substantial runoff. A human mandible was discovered and photographed in situ during a biological survey in 1998 (KIBLER, 2002; VENI, 2008). The isolated mandible was assumed washed into the cave as no other archeological associations were documented. After the discovery of the mandible, no further entry was allowed into the cave. The cave was not given an archeological site number since the presence of archeological materials or additional human remains could not be confirmed.

Bradford Cave in Real County is known from Texas Speleological Survey files. The site produced both skull and other human bone fragments.. Also known as Pape (pronounced "poppy") Cave, Bradford Cave is a large and well-decorated cave with nice totem poles and other speleothems (ELLIOTT and VENI, 1994:247). University of Texas cavers first entered the cave in 1951 and discovered the skeleton of an Indian boy in the farthest part of the cave.

His knees were drawn up to the shoulders, and his arms were lying across his knees. The bones were poorly preserved but were identified by the Texas Memorial Museum. Years later, David McKenzie found human bones in another part of the cave.

Laubach Cave (Inner Space Cavern) produced one human molar (LUNDELIUS, 2009, personal communication) during an excavation of Pleistocene remains (LUNDELIUS, 2005). It was loosely associated with Dire wolf remains in one of the five talus cones or "bone sinks" as they are referred to, each open at a different time in the Pleistocene (ELLIOTT and VENI, 1994:63). Radiocarbon dates from three of the cones range from 13,970 to 23,230 years before present. The site remains problematical.

Rucker Cave, is a horizontal shaft with water adjacent to a large burned rock midden. There is no data concerning the human burial material found in the cave (EVANS, 1991).

Shulze Cave in Edwards County contained nine individuals, 8 adults and 1 child. The deposit was radiocarbon dated to 3826 +/- 280 years before present (DALQUEST et. al., 1969). Two teeth came from below a travertine cap indicating a Pleistocene age. This site is problematic.

Y Cave, also known as Whitten Cave, in Schleicher County, has been rumored to contain human bone. The cave is closed and neither cavers nor archeologists have confirmed the reported burial (MEADOR, 1965).

3. Summary

A great deal of survey work is now being conducted in Central Texas. This is due to population pressures as development expands away from city centers. There is also an impetus for state and federal agencies to inventory lands under their control. This has led to widespread bio-speleological inventories that often result in new discoveries of human remains. Both cavers (professional and volunteer) and archeologists (professional and avocational) perform these inventories.

What do you look for if you are about to enter a cave for the first time? There are several indicators such as loose bone on the floor, fire-blackened ceilings and the presence of human artifacts that should signal possibly significant archeological remains. So, if you are caving in Texas and come across bones or artifacts, who do you contact? Archeologists are found in every major city and the Texas Speleological Survey website is a good place to look for a contact name. Most grottos in

Texas can also steer you toward a local archeologist. Be ready to show pictures, a sketch map and GPS coordinates.

And in Texas, what are the applicable regulations on private and public lands? In general, the landowner owns the cave and everything inside. If the land is owned by the federal government or the project is federally permitted, human remains fall under NAGPRA or the Native American Graves Protection and Repatriation Act. This federal law, passed in 1990, requires archeologists to consult with Native American groups to determine where and when human bone and associated cultural items recovered during excavation should be returned to the respective peoples. Cultural items include funerary objects, sacred objects and objects of cultural patrimony. Land owned by or under the control of the State of Texas (or any of its municipalities) falls under the Texas Antiquities Code. The Texas Historical Commission issues permits for excavations and section §131 of the Antiquities Codes prohibits anyone from intentionally or knowingly defacing an American Indian or aboriginal site including burials. Further, this section also requires owner's permission for actions on private lands and provides penalties for violations.

References

- ALVAREZ, C.E. (2005) Bioarchaeological Investigations of Human Skeletal Remains at the Stiver Ranch Burial (41KM140). Masters Thesis, Texas State University, San Marcos Texas.
- BEMENT, L.C. (1994) Hunter-Gatherer Mortuary Practices during the Central Texas Archaic. University of Texas Press, Austin, x + 165 pp.
- BENFER, A and R.A. BENFER (1962) A Vertical Cave Burial in Uvalde County, Texas. *Texas Caver*, 7:41-42. Reprinted in: *Speleo Digest*, (1964) **1962(2):15-17.**
- CARPENTER, S.M., S.C. CARAN, D.K. UTLEY and S.A. TURPIN (1996) Divides and Draws: The Cultural Resources of Kickapoo Cavern State Natural Area, Kinney and Edwards Counties, Texas. Texas Parks and Wildlife Department, Cultural Resource Program, Report 96-5, Austin, xi + 118 pp.
- COLLINS, M.B. (1970) On the Peopling of Hitzfelder Cave. *Bulletin of the Texas Archeological Society* **41:301-304.**

- COLLINS, M.B., C.B. BOUSMAN, P. GOLDBERG, P.R. TAKEC, J.C. GUY, J.L. LANATA, T.W. STAFFORD and V.T. HOLLIDAY (1993) The Paleoindian Sequence at the Wilson-Leonard Site, Texas. *Current Research in the Pleistocene* **10**:10–12.
- DALQUEST, W.W., E. ROTH and F. JUDD (1969) The Mammal Fauna of Schulze Cave, Edwards County, Texas. *Bulletin of the Florida State Museum, Biological Sciences* **13**:205–276.
- ELLIOTT, W.R. and G. VENI (Eds.) (1994) *The Caves and Karst of Texas*. National Speleological Society 1994 convention guidebook, Brackettville, Texas, vii + 342 p. + 13 plates.
- EVANS, G. (1991) The Rucker Cave, Edwards County, Texas. *La Tierra*, **18**(1):33-34.
- FRALIA, B. (2000) Palo Pinto dig. *The Maverick Bull*, **13**(4).
- GIVENS, R.D. (1968) A Preliminary Report on Excavation at Hitzfelder Cave. *Bulletin of the Texas Archeological Society* **38**:47–50.
- HAMILTON, D.L. (2001) *Prehistory of the Rustler Hills: Granado Cave*. University of Texas Press, 296 pp.
- HENDERSON, J. (2001) Excavations at the Rainey Site (41BN33), A Late Prehistoric Sinkhole Site in Bandera County, Texas. Texas Department of Transportation, Environmental Affairs Division, Archeological Studies Program, Report 5, Texas Antiquities Committee Permit No. 245. 343 pp.
- KIBLER, K.W. (2002) An overview of archeological and paleoenvironmental research potential of caves and other karst features at the Camp Bullis Military Reservation, Bexar and Comal Counties, Texas. Letter Report No. 531, Prewitt and Associates, Inc., Austin, Texas, 18 pp.
- LUNDELIUS, E.L. JR (2005) *Inner Space Cave: Discovery and Geological and Paleontological Investigations*. Technical Papers in *Austin Geological Society Bulletin, Volume 1*, Texas, pp 53–69.
- M McNATT, L., C. BECEIRO, M.D. FREEMAN, M. HOWARD, S.A. TOMKA, P SCHUCHERT and C.G. WARD Archeological Survey and History of Government Canyon State Natural Area, Bexar County, Texas. Texas Antiquities Permit 1669, Cultural Resources Program, Texas Parks and Wildlife, Austin., 145 pp.
- MEADOR, T (1965). Y Cave. *Texas Caver*, **10**:96.
- PARSONS, M. (1967) Field notes. Texas Memorial Museum Archeological and Biological Survey, notes on file at the Texas Archeological Research Laboratory, Austin.
- PREWITT, E.R. (1981) A Wooden Mortar from the Stockton Plateau of Texas. *Journal of Field Archeology*, **8**(1):111–117.
- RALPH, R. (1996a) An Inventory of Cultural Resources within the Texas Park System: November 1976 through October 1981. Texas Parks and Wildlife Department, Report PWD RP P4200-035, Austin, 389 pp.
- RALPH, R. (1996b) Government Canyon State Natural Area. In Texas Parks and Wildlife Department Annual Report for 1995, Cultural Resources Program, Texas Parks and Wildlife Department, Austin, pp 209–215.
- RALPH, R. (1997) An Inventory of Cultural Resources within the Texas Park System: November 1981 through October 1986. Texas Parks and Wildlife Department, Report PWD RP P4200-035a, Austin, 256 pp.
- SKINNER, S.A., H. HAAS, and S.L. WILSON (1980) The ELCOR Burial Cave: An example of Public Archaeology from West Texas. *Plains Anthropologist*, **25**:1–15.
- STEELE, D.G., K.E. BYRD, L. McNATT, and G. VENI (1984). Human and Non-human Skeletal Remains Recovered from Sorcerer's Cave, Terrell County, Texas. *Texas Journal of Science*, **36**(2&3):169–184.
- TRIERWEILER, W.N. (Ed.) (1994) *Archeological Investigations on 571 Prehistoric Sites at Fort Hood, Bell and Coryell Counties, Texas*. Archeological Resources Management Series, Research Report No. 31. U.S. Army, Fort Hood.

TURPIN, S. and L. BEMENT (1988) Seminole Sink:
Excavation of a vertical shaft tomb, Val Verde
County, Texas. *Plains Anthropologist*, **33**(122,
part 2), 156 pp.

VENI, G. (2008) Hydrogeological, Biological,
Archeological and Paleontological Karst
Investigations, Camp Bullis, Texas, 1993-2008.
Zara Environmental LLC and George Veni and
Associates, Carlsbad, New Mexico. Technical
report prepared for Natural and Cultural Resources
Environmental Division, Fort Sam Houston, Texas,
2,736 pp.

GEOARCHAEOLOGICAL CHARACTERIZATION OF ROCK SHELTERS IN A KARST CONTEXT IN MINAS GERAIS (BRAZIL)

MARIA JACQUELINE RODET¹, JOËL RODET^{2*}

¹ Archeologist PhD, FAPEMIG granted, Setor de Arqueologia, MHN/UFMG, Belo Horizonte, Brazil

<jacqueline.rodet@gmail.com>

² UMR 6143 CNRS-Continental and Coastal Morphodynamics, Laboratory of Geology, University of Rouen, 76821 Mont Saint Aignan, France <joel.rodet@univ-rouen.fr>

* corresponding author

Karst has been intensely used by prehistoric groups who left evidence of their passage or their stay. In contrast to many other areas, particularly Central America, Brazilian caves were not utilized by the first occupants who seem to have stopped in the entrance of caves. It is why the notion of rock shelter prevails. This concept is complex and evolves from the simple hollow at the foot of a cliff to the cave entrance, also taking into account the old gallery intersected by a topographic cut, though it does not seem discriminating in respect to anthropogenic use. Mixed sites have frequently been observed, the rock shelter supplementing the occupation of a surface archaeological site at its front. What can thus be the function of the rock shelter? It appears that all the rock shelters have been occupied, at least temporarily, occasionally or perennially. Above all, one notices they provide evidence of specific use (stopping-place for hunting, bivouac on a journey, etc.) and at times during the last occupations cultural or even spiritual connotations seem to be indicated by rock art (engravings, drawings, paintings) or by burial remains (sepulchres, offering silos, etc). Rock shelters held a significant role in the identification and the structure of prehistoric space. Further study of rock shelters will allow a better understanding of the spatial organization of human communities before the arrival of the European invaders.

1. Introduction

Prehistoric humans have used caves for graphic expressions throughout the world. Some subterranean sites like the caves of Lascaux, Altamira, or Chauvet acquired equivalent status to the greatest artistic works of the world. Curiously this can't be applied to Brazil. Brazil is a vast tropical country with a large geological diversity. The bioclimatic conditions and the long exposure of substrates to agents of erosion since the Cenozoic have been responsible for the deep karstification of very diverse lithologies, such as limestone, sandstone, quartzite, granite and even itabirites (iron ore). Brazilian landscapes offer numerous caves, sometimes very impressive because of the huge size of some conduits that exceed 100 m in height, but no prehistoric human occupation has been identified in those places. By "prehistoric" we mean prior to the arrival of European conquerors, between 1500 and the eighteenth century, i.e. equivalent to European prehistory. The most obvious evidence of use is expressed in graphical form on the walls of rock shelters (shelters under rock). Rock shelters include hollows in cliff or rock walls that provide shelter during inclement weather, but also cave entrances where daylight penetrates. These shelters are numerous and have diverse origins. In Central Brazil, they can be classified according to a geomorphological typology (Fig. 1). Archaeological studies have shown very clearly the

fundamental role of shelters in the prehistoric occupation of the Brazilian space. They contribute significantly to the ownership of this area, reflecting both the daily lives of the human groups and the cultural space-temporal status that they represent in these populations. Shelter use does not correlate well with their geomorphic typology.

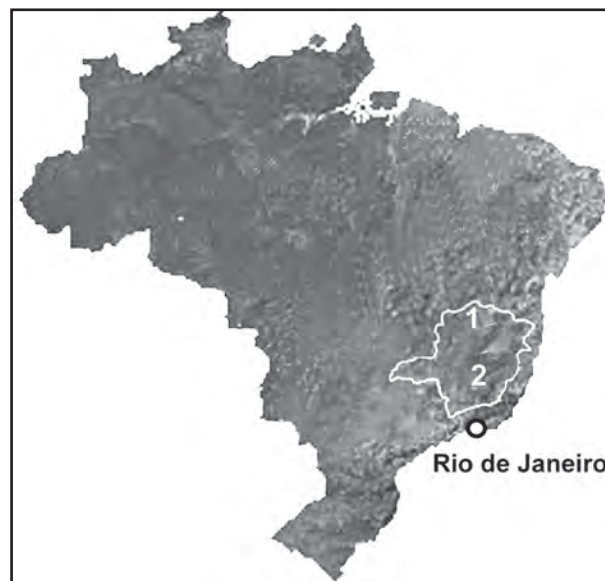

Figure 1: Location of the state of Minas Gerais in Brazil. 1: Peruaçu Basin, 2: Lagoa Santa area.

Perhaps rock shelters have acquired such an important status, because the dark-zones of caves apparently have been excluded from use, as if they are reserved for the non-living or spiritual dimension.

2. The Cave, the Shelter and the Archeology

In karst, the rock shelters are often ancient conduits that were cut and reduced by erosion. These shelters (hollows, remains of cavities, or cave entrances) benefit from the light of the day. They are frequently a site of rock art (engravings, drawings, paintings), sometimes very spectacular (PROUS, 1991). Curiously these engravings and drawing end in the penumbra or twilight zone: the contrast is astonishing and interrogative (RODET and RODET, 2007). The dark part of the caves reveal no evidence of passage or use by prehistoric groups. This may be due to the lack of systematic research, but none of the large number of cavities explored, have shown any evidence of dark-zone use.

This study of the use of shelter caves, includes a classification of form as well as a characterization of their use. Although the number of shelters in the northern part of the state of Minas Gerais is relatively large (several hundreds of sites), few have been the subject of comprehensive archaeological investigations (surveys, etc.). Although they are all systematically identified and the vast majority is studied for their rock art content. This large number of shelters represents a wide variety of morphological diversity.

3. The Geomorphological Diversity of the Shelters

The great morphological variety of shelters can be grouped into six classes (Fig. 2) formed from the examples offered by the Rio Peruaçu Basin, a tributary

of the great São Francisco river (RODET et al., 2009), they range from the simplest to more complex forms:

Simple hollow-rock shelter: is a simple hollow at the foot of the cliff that offers shelter from the rain. Often, these rock shelters are former subterranean drains longitudinally cut by the surface topography. The walls protected from rain generally receive archaeological paintings, engravings, and drawings. They sometimes contain residual lithified fill. Pimpo II offers a palaeo-karst fill containing the raw material used for incision, pecking, or as pigment (Fig. 2-1).

Simple cave-rock shelter: is a shallow karst cavity truncated by surface erosion, and in which light enters. Their size is more limited than in the under-simple hollow-rock shelter, by the walls of the gallery. There is no area of total darkness. The Boquete shelter has been a site of excavations for many years (Fig. 2.2). Furthermore its use extends beyond the dripline and at its entrance, funerals, offerings, structures

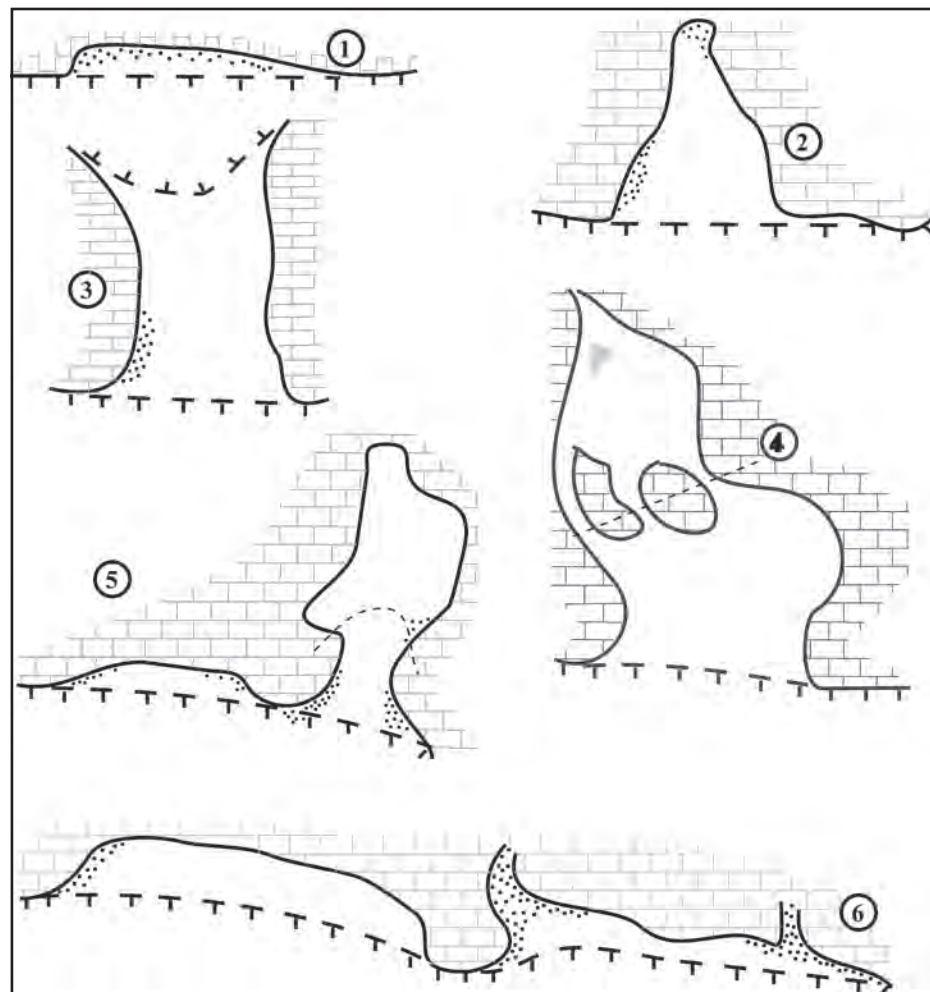

Figure 2: Typology of rock shelters, with plan view examples from the Peruaçu Basin. 1: simple hollow-rock shelter; 2: simple cave-rock shelter; 3: rock shelter-tunnel; 4: rock shelter in cave entrance; 5: hollow rock shelter associated with a cave; 6: complex rock shelter.

of occupation and cutting activity were studied, while engravings and paintings adorn the walls in the periphery.

Rock shelter-tunnel: is a passage segment, which allows light to enter the entire tunnel. At Bichos cave, the size of the conduit is such that the unit is illuminated, with paintings up to the roof of the cave, more than 20 m in height (Fig. 2-3). Excavations in progress should reveal the different functions of the site.

Rock-shelter in cave entrance: is a site developed at the entrance of a cave. Only the entrance area is illuminated and the deep part is in total darkness. In the Indio cave, all of the entry seems to have been occupied (Fig. 2-4). Passage into the dark-zone are restrictively small and nothing of archaeological interest has been observed in the distal part where rimstone dams retain water during the dry season. This water represents a reserve that could be used by prehistoric groups but there is no evidence of its use. This case also applies to the gallery-like tunnels in Rezar cave or Janelão cave.

Hollow rock shelter associated with a cave: is a rock shelter developed at the foot of the cliff and one part extends into passage where light does not penetrate. At Desenhos site, the rock shelter is widely used (painting panels placed more than 10 m in height), but it seems that the cave has not been used, at least in its dark zone (Fig. 2-5).

Complex rock shelter: is a shelter complex at the foot of a cliff, where shelter areas alternate with cave entrances more or less well illuminated by daylight. There is no evidence of dark zone use. Malhador site (Fig. 2-6) and Poseidon cave (Montalvânia) illustrate these large rock shelters where space is differentially used, depending on the morphological context. Thus at the entrance of the cave where pellicle calcite is developed, there are engravings by pick. At Malhador, there are funerals, paintings and drawings, engravings, lithic extractions. The coexistence of several anthropological functions is facilitated by the length of the shelter, about a hundred meters.

The criteria that characterize the rock shelters are of two types. There is the spatial dimension (extent, depth, etc.), and the morphological complexity (light / dark, open / closed, etc.).

4. The Archaeological Context

The state of Minas Gerais (Fig. 1) was occupied by prehistoric people from at least the Pleistocene / Holocene transition (12,000 BP) until the contact with Europeans

(18th century for Peruaçu sector). The older occupants have Negroid features (Lagoa Santa), and from approximately 8000 BP, people are certainly Siberian.

The examination of different types of rock shelters shows that if the geomorphological context indicates the potential use of shelters by prehistoric groups, the type of shelter has little impact on the occupation by these groups, even if a large shelter allows a priori more usage than a small one. Thus the absence of lithic resources in the shelter eliminates the mining dimension but not the lithic debitage. In fact, all the shelters are occupied at one or another time.

Curiously, no prehistoric artifacts or evidence of use have been observed in the dark-zone of a cave of Central Brazil. Only the illuminated area was used. This lack of evidence in the non-illuminated part raises questions about the significance of the cave: was it a place for a ceremonial activity (M.J. RODET, 2006; RODET and RODET, 2007)?

Our research was essentially focused in northern Minas Gerais, where the 17 km of the Grand Peruaçu Canyon allowed the observation of a wide variety of archaeological evidence (RODET et al., 2009). But not all the rock shelters were used in the same way. M.J. RODET (2006) suggested a classification of sites based on the function of the archaeological identified elements (Table 1). First, note that Peruaçu shelters were not used as habitat or place of long-term residence, at least no known evidence suggests such a use. Moreover, the scarcity of tools, combined with the presence of some fire-places with little remains of food, suggests a stopping place on a journey. It is quite possible that the canyon, turned into a path because of the shelter possibilities, the constant presence of water and the food associated with the river and the easy route along the river, could be used as a passage from one sector to another in the basin, particularly to hunting and gathering places in the upper valley.

The debitage and middens that define the sites of production (place of lithic production) and consumption (frequented place, place of temporary or permanent residence) are absent or discrete in Peruaçu shelters. Other evidence is present and suggest that these places were used as much in ceremonies (funerals, offerings, graphics, ...), as in passage for resting, hunting, etc. (small fire-places with food remains, collection of the raw material). The almost total absence of the characteristic tools of domestic work, the presence of fire-places with very few food remains, and the dispersion and / or the great of number of fire-places suggest

	Intermediate		
Site of production (Pelegrin, 2005)	Site of resting or passage (Rodet, 2006)	Site with “ceremonial” vocation (Rodet, 2006)	Site of consumption (Pelegrin, 2005)
Abundance of rough debitage (1st phases).	Rare beginning debitage flakes	Absence of rough debitage (or very rare).	Few beginning debitage vestiges
Absence / rarity of true tool / the intention Broken, failed tools ...	Few more-sophisticated tools (unless broken) Broken tools Presence of some nucleus and simple tools, more <i>summary</i>	Tools of prestige?	Relative abundance of tools Used tools Broken, abandoned tools
Fortuitous presence of extraction equipment	Absence	Absence	Absence
Fortuitous presence of reduction and retouching flakes	End-of-chain flakes that correspond to the resharpening to the reduction or to the <u>retouching</u>	Scarcity or absence of reduction / retouch flakes	Fortuitous presence of retouching and reduction flakes
Fortuitous abundance of nuclei (if debitage)	Few sophisticated nuclei	Scarcity or absence of nuclei	Possible presence
	Dispersed fire-places Small concentrated Fire- places Fire-places with low food remains	Fire-places	Big fire-places Abundant but sometimes evacuated remains of wildlife
	?	Graves	Possibility of burials
		Graphics / Paintings Pigments Silos / offerings?	Possible Pigments

Table 1: The types of sites: the vestiges found in the sites of Peruaçu shelter suggest that these sites had a “passage” role: follow the river to get from one point to another, stopping for specific tasks or to sleep. If a site has characteristics that belong to another type, this may indicate an evolution in its status (RODET, 2006).

only brief visits *versus* a habitation usage. Finally, a type of usage does not exclude another: for example, a ceremonial site may be used as a site of passage.

The placement of fire-places is an interesting indicator. We recognize 3 to 4 cases of use depending on the size, placement, and concentration of fire-places in a shelter:

1. lack of fire-places: very sporadic and brief use by small groups,
2. several scattered fire-places: probably temporary, occasional or repeated use, possibly by different groups (successive generations),
3. large concentrated fire-places in the same restricted space: probably a permanent occupation or

regularly repeated in a concentrated and organized space,

4. several small fire-places concentrated in the same place: a permanent occupation by a very small group or repeated visits by groups that do not live in the shelter.

The permanent occupation, even by a very small group, should show the tools in an advanced state of use: This is not the case, according to the current state of knowledge.

In the Peruaçu (e.g. Boquete and Malhadador shelters) during the first occupations, one can observe small fire-places concentrated in a specific part of the shelters. This location seems more linked to practical problems (ventilation): near the overhang more than the bottom, which makes

possible the evacuation of smoke, and limits the effects of condensation at the entrance dripline of the shelter, especially during the rainy season (occupation proved by vegetal remains).

5. Cave and Shelter, “Complementary Spiritual Spaces”?

How did prehistoric groups see their space? We must understand that the shelters are one of the dimensions of the lives of pre-historical groups. These are groups which one can imagine were based in strategic locations such as the São Francisco - Peruaçu confluence which allows access to the river (fish and travel path) and small rivers around, but at the same time, moving across all their territory. Indeed one can imagine that within the group of individuals, some are more mobile and circulate throughout their territory, while other less mobile individuals and groups stay longer around a site or around some seasonal sites. Between these two types of camps (perennial and seasonal) there are intermediate sites, visited for more specific reasons and much briefer, such as the lithic mining or processing, ritual, or sites of passage ... These sites were used at different times of the year, which is demonstrated by the great diversity of plant remains in the shelters. The visits could be random depending on the usage and needs. Accordingly, these sites appear to be, for the archaeologist, markers of the territory of usage dimension.

Initially (12000–10000 B.P.), the shelters are used discreetly: some fire-places with little animal and plant remains, as well as some abandoned fire-fragmented tools. During the second period (10000-8000 B.P.) behavior is not very different. The fire-places and lithic remains are always representative of a brief visit, during which some tool kits are reworked and used. The most important changes in the occupation pattern of these sites takes place around 9000 B.P, when the first sign of a graphic cut on a limestone block occurs, then around 8000 B.P., when fire-places contain not only leftover food, but also pigment spots.

Changes in the occupation of the shelters persist until around 7000 B.P. and the first appearance of funerals. In the following periods (between 4000 and approximately 700 B.P.), the ritual or symbolic purpose of these shelters seems established. Beyond containing those elements, these spaces are used for the domestication of plants, for local “storage” of large vegetal baskets that are buried. These materials are probably offerings because the volume and weight of deposited plants around 2 kg for the heavier ones, the large number of fruit partially eaten found in the baskets or the nature of certain objects (feathers, iron nails, beads). It suggests that these material are intended for something else

than food storage (RESENDE and CARDOSO, 1996). In addition, these shelters are covered with rock paintings. The only direct dating of the paintings places them, at least in part, around 3000 B.P. This suggests a link between the cave paintings and pigments.

The last occupation shows a remarkable change in use. Previously, few tools were left in the shelters, during this last phase some shelters contained many more tools. The number of fire-places increase and the material remains change and are diversified. These changes may reflect an invasion that destabilizes the traditional way of life of these populations, expels the Indians from their places of daily life, forcing them to hide in more remote areas, with more difficult access, such as the canyon shelters. Accordingly, the shelter function may change, as well as the frequency of use.

In Europe, caves are “sacred” places of prehistory, whereas in the state of Minas Gerais no evidence has been found of the prehistoric use of caves. Native groups stopped in the entrance area and only the shelters were “sanctified”. The shelters may be a “door” to spirituality. In any case they are a geomorphological boundary between the empty and dark subterranean and the outer life, with the light and the green ... They are also an anthropological feature as representative of cultural and ceremonial events, illustrated by paintings, burials, lithic industries, etc. It is possible that, despite a lack of anthropic evidence, caves were able to hold an important place in the imagination of these people. A great part of Peruaçu shelters represent a karst context.

If the shelters include a symbolic dimension, they don't give a complete representation of the industries of these populations. The burials are likely to offer a reduced vision of these cultures because of the lack of lithic tools and ceramic objects. Nevertheless the rare lithic tools or ceramic objects these sepultures offer are surely among the most cultural meaning marked objects produced, even though their small numbers limit our understanding.

6. Conclusions

The use of karst by prehistoric groups of Minas Gerais is limited to surface-forms, in particular rock shelters. One can note a wide morphological diversity of shelters and different usages, sometimes combined, but there is no evident correlation between the morphological type of rock shelters and the type of archaeological usage. There is need for research of the distribution of usages not in the form of the shelters, but in their spatial-social situation, being changeable with time and evolution, even the succession, of the occupant groups.

References

- PELEGRIN, J. (2005). *Cours de D.E.A.* Université de Paris X-Nanterre, Laboratoire d'Archéologie et de Technologie lithique.
- PROUS, A. (1991). *Arqueologia brasileira*. Editora Universidade de Brasília, 613 pp.
- RESENDE, E., and J. CARDOSO (1996). Estruturas de armazenamento vegetal : os "silos" do vale do rio Peruaçu (MG). Anais da VIII Reunião Científica da Sociedade de Arqueologia Brasileira, Porto Alegre, EDIPUCRS, *Coleção Arqueologia*, **1** (2): 249–264.
- RODET, J., M.J. RODET, L. WILLEMS, and A. POUCKET (2009). Abordagem geomorfológica da bacia do rio Peruaçu e implicações geoarqueológicas. *Arquivos do Museu de Historia Natural*, UFMG, Belo Horizonte (in press).
- RODET, M.J. (2006). *Etude technologique des industries lithiques taillées du nord de Minas Gerais, Brésil, depuis le passage Pléistocène/Holocène jusqu'au contact - XVIIIème siècle*. PhD thesis, University of Paris-X, Nanterre, 516 pp.
- RODET, M.J., and J. RODET (2007). Grottes, abris sous roche et perception de l'espace préhistorique au Brésil. Exemple de l'état de Minas Gerais. *Actes du 12° Congrès National de Spéléologie*, Société Suisse de Spéléologie, Vallée de Joux, 15-17 Septembre 2007, 11–15.

PREHISTORIC CAVE ART IN SOUTHEASTERN NORTH AMERICA

JAN F. SIMEK¹, ALAN CRESSLER²¹*Department of Anthropology, University of Tennessee, Knoxville, TN 37996-0720 USA*²*United States Geological Survey, Atlanta, GA, USA*

Over the past two decades, nearly seventy caves in the Southeast of North America have been discovered that contain prehistoric artwork in the dark reaches of the caverns. Beginning in the Archaic period (ca 6,000 years ago), this practice developed until a florescence during the late prehistoric Mississippian period (ca 700 years ago). It is clear from the nature and context of these sites that cave art was part of a ceremonial use of the underground reflecting cultural perceptions of the underworld and its place in the human cosmos.

1. Introduction

This paper is designed to serve as a current overview of a prehistoric cave art tradition that has only come to light over the past two decades in the Appalachian Plateau uplands of Southeastern North America. First identified by archeologists in 1980 (FAULKNER, 1986), this cave art represents a widespread, complex and longstanding aspect of indigenous prehistoric culture, one with local origins and development and one intrinsically linked to the evolution of prehistoric Southeastern religious iconography. There have been a number of general discussions of this cave art published, but as our efforts to discover new caves continue, the number of known sites grows dramatically and at a rapid rate. Our last review, written in 2005 and currently still in press (SIMEK et al., in press), examined a cave art record that included 49 known sites. As we prepare this paper, written only a few years later, there are 67 known cave art sites in the greater Southeast prehistoric culture region, including caves in Alabama, Arkansas, Florida, Georgia, Kentucky, Missouri, Tennessee, Virginia, and West Virginia. New sites are literally discovered every few months, and discoveries are still a direct result of survey intensity in the region's caves. Although we have now examined more than 1000 southeastern caves in hopes of finding prehistoric art, there are more than 9000 caves recorded in Tennessee alone by the Tennessee Cave Survey, with thousands more in Alabama, Georgia, etc. There is a great deal of survey work still before us, and there will certainly be more caves to discuss in the future. Our discussion here will follow quite closely our earlier overviews in format, employing our larger samples to expand on what we have presented already based on fewer sites.

Dark zone cave art (decoration in the areas of caves beyond the reach of external light) was actually known among a small group of cavers in the Southeast from the 1950's. Engravings that were thought to be prehistoric by those

cavers who saw them were identified at the mouth of 12th Unnamed Cave. The site remained a relative secret, unknown to archaeologists, until Charles Faulkner of the University of Tennessee was taken there in the 1980's. Faulkner had begun the first archaeological study of a Tennessee cave art site, Mud Glyph Cave, in 1980, and he had made inquiries among the caving community about the possibility of other prehistoric cave art sites in the region. Mud Glyph Cave itself was discovered in 1979, when a recreational caver explored a narrow subterranean stream passage and saw images incised into the wet clay lining the stream banks. Upon seeing the site, Faulkner quickly recognized that the art was prehistoric, and he initiated a documentation project. Mud Glyph Cave art was seen as resembling that found on Mississippian period ceremonial objects (ca AD900-AD1600) and therefore linked to the widely known Mississippian religious iconography. Other cave art sites began to be recognized, some in caves visited recreationally and scientifically for many years.

Since the discovery of Mud Glyph Cave, dark zone art has been recorded in 66 other caves in the karst regions of the Southeast and Midwest. Chronological data from these sites demonstrate a long-term regional tradition of cave art unrecognized before the 1980's. As FAULKNER observed (1986), some of the imagery can be understood in terms of other prehistoric iconography, but some has less obvious connection with that imagery. It is clear that the existence of a major prehistoric cave art tradition in the Southeast is no longer at issue. We can now turn our attention to trying to understand this art, what it meant to those that made it, and its role in complex prehistoric Southeastern symbolic and ceremonial behavior.

2. The Sites

As we have noted before, southeastern cave art sites occur in a variety of environmental contexts. There are very few

patterned relationships between specific or characteristic site environments and the presence or nature of cave art, although there are some consistent aspects. Some art caves are long (more than 500m of passageways); some are short (less than 500m). Some caves have flowing water near the area where art assemblages are found, while many have no water in the vicinity of the artwork; nevertheless, most art caves do have water somewhere in the karst system, although this is a general characteristic of caves generally in Appalachia. Most of the known art caves are in the Appalachian Plateau physiographic province. In this region, art caves tend to have entrances oriented generally toward the south although caves in general have no such patterning; this tendency is statistically significant and must represent a choice, conscious or unconscious, by prehistoric cave users given the range of entrance aspects possible in the area. Thus, while we are beginning to see patterning in art cave locations, we are still unable to fully predict where cave art sites will be within the more than **20,000 known caves of the Southeast**.

3. The Nature of Southeastern Cave Art

Parietal cave art in the Southeast comprises engraved petroglyphs in stone, painted pictographs of mineral pigments, charcoal and clay, and (perhaps the region's "signature" art form) mud glyphs incised into damp clay. It was reported in historical accounts that stone and clay sculptures were also found in southeastern caves, although no example has been discovered in the modern era, although there may be mud sculptures in one Virginia cave. There is variation in where these different art types can be found: pictographs and petroglyphs are also found both in the dark zone and on exterior rockshelter walls and bluff faces. Mud glyphs are found exclusively inside caves. Most often, only one kind of art is found in a given cave. There are, however, some exceptions to this. Mud glyphs and petroglyphs are occasionally found in the same cave, but one or the other form is always numerically dominant. Pictographs are often found in association with other art types, but this is because they are quite the rarest form, anyway. There are at least three sites with all three parietal art forms.

There is a great deal of variability in the archaeological contexts of Southeast cave art, and this, in part, reflects the complexity of prehistoric cave use more generally in the region. In 1986, Patty Jo WATSON defined four types of prehistoric cave use in the eastern woodlands, including exploration (witnessed by torch remnants and footprints), mining (witnessed by industrial extraction of some raw materials), burial, and ritual/ceremony caves (witnessed by the presence of cave art). In fact, prehistoric cave art in

our sample is associated with all of these uses. Nearly every cave art site has evidence showing that prehistoric explorers examined the entire cave, often visiting many miles of passageways, not just where the art was produced. A number of the sites in our sample are (or were) burial caves. None of these burial caves is very long, although lightless reaches are present in many of them. Cave art sites as burial contexts, therefore, may have something of an attribute focus. A smaller number of caves show evidence of cave art in association with clay, chert, or mineral mining. These caves can be quite extensive, requiring long and arduous treks to where the mining and art are located. In at least three cases, art, mining, and burial were all performed in the same cave.

There does seem to be some patterning with respect to context. Caves that contain both burials and art typically have only a few art images, and these tend to be quite specific motifs. In non-burial sites, there can be very few prehistoric glyphs produced in only one medium, but more common are sites having many glyphs present in the art assemblage. All of the cave art sites in Kentucky and Virginia, and many sites in other states, are of this latter, rich type, making it the most widespread and diverse class. The more simple sites (those with only a few glyphs) are also widely distributed geographically, but are most common in Tennessee. This may be partly an artifact of our own survey zone and the fact they are sometimes rather difficult to detect.

As has been noted, much of the subject matter of prehistoric Southeast cave art seems related to late prehistoric religious iconography. The images in many sites reflect the central tenets of Mississippian religion: ancestors, nature, warfare, and transformation, but prior to the Mississippian, subject matter is different. In many sites created before AD900, geometric shapes, lines, and representational figures are present that have no reference in known prehistoric religious imagery. And there is some variation by medium. Most of the pictographs in our sample are representational images, although more abstract pictographs are known from a number of sites. Petroglyphs also frequently depict religious icons, animals or anthropomorphs, but abstract lines and shapes are also common as engravings into the rock substrate. Mud glyphs are quite variable and include anthropomorphs, animals and even insect effigies, abstract shapes, and linear figures. Masses of meandering lines are common in mud glyph panels, and these create problems in deconstruction and interpretation.

4. Chronology of Prehistoric Southeast Cave Art

Assessing the chronology of prehistoric parietal art is a

difficult problem around the world, as the artwork “floats” above sediment deposits that might otherwise provide archaeological context. Two kinds of dating have been employed in trying to place southeastern cave art images into temporal context. The first is stylistic dating, where the images themselves are related to similar ones found in contexts with better chronological control, such as artifacts with associated dates. Second is chronometric age determination on artifacts associated with the creation of the images, like ^{14}C decay assay of torch charcoal fragments from the floor below the images or even from **smudge marks left on walls and ceilings by ancient torches**. We will consider each of these methods in turn.

4.1. Style

The association of sites or specific images with the Mississippian has been based not only on ^{14}C determination but also on characteristic icons identified in other, firmly dated archaeological contexts. In particular, icons associated with the Mississippian in ceremonial contexts outside caves, like mounds and cemeteries, appear in both obvious and stylized forms in dark zone cave art sites. For example, bird/human images, often holding weapons or maces, are known from a variety of Mississippian open site contexts and have also been seen in caves as petroglyphs and as stylized mud glyph images.

Based on the presence of these and other icons, some parietal works can be given temporal parameters because of their style and/or content. Many images are reasonably ascribed to the Mississippian on these grounds. It should be noted that ^{14}C age determinations associated with Mississippian icons confirm the stylistic attributions in every case. Only one ^{14}C determination from Mud Glyph Cave, for example, falls outside the Mississippian period. For the most part, chronometric and stylistic age attributions are in agreement.

Stylistic dating of cave art from before the Mississippian is more problematic. Cave art from the Woodland Period (1000 B.C.–A.D. 900) and the Archaic (8000 B.C.–1000 B.C.) does exist, demonstrating participation in this tradition by these people. However, early art is for the most part less elaborate, less representational, and often includes images for which there are no known religious referents. It is important to observe, however, that there is less of a corpus of artistic renderings on religious artifacts from outside caves to facilitate stylistic correlation. Woodland period sites in the Southeast do contain elaborately decorated ceramics; some decorated stone, bone and shell artifacts that seem to anticipate Mississippian religious paraphernalia; and

evidence for connections with artistically rich cultures like the Ohio Hopewell. Yet organizations of specific symbols, seen as a true iconography during Mississippian times (and therefore a source of stylistic data), simply are not recognized for the Woodland Southeast. Symbolic representations from the Archaic Period are even rarer, although sculpted banner-stones, engraved bone, beadwork, and cut shells do occur with some frequency. Southeastern Archaic people also buried their dead in large cemeteries, despite their nomadic hunter-gatherer life ways, and are justly renowned for elaborate burial treatments for their dogs, as well. Still, nothing like an iconography has been recognized for Archaic cultures. In essence, we cannot estimate cultural affiliation for pre-Mississippian works based on stylistic similarities with artifacts from well-dated contexts.

4.2. Chronometric dates

At present, we have more than 120 chronometric age determinations associated with Southeast dark zone cave art. These ages mostly confirm age estimates based on style, and they also show that cave art has great time depth in the Southeast. Several determinations show that artwork in deep caves was first produced during the Late Archaic period (before ca 1000 B.C.). A number of dates also implicate Woodland period involvement in cave art production. The great majority of cave art dates cluster at the later end of the region’s prehistoric sequence, in the Mississippian period (after A.D. 900). Therefore, cave art in the Southeast clearly has a relatively great time depth, spanning more than 4000 years, and comprises a great deal of ecological and cultural variability.

The earliest age determination for Southeast cave art is, in fact, a direct AMS date on a charcoal pictograph from 48th Unnamed Cave near Knoxville, Tennessee, which yielded an age of 4980 ± 35 B.P., calibrated to 3790 B.C. during the Late Archaic period of East Tennessee. This pictograph is a complex representational image of a human, possibly hunting a quadruped. A number of human burials have been identified at 48th Unnamed Cave, all located on what were once probably ledge areas away from the glyphs just noted. Slightly later, Terminal Archaic ages have been obtained in association with parietal artwork from very deep cave contexts. In 1996, DiBlasi described mud glyphs from Adair Glyph Cave in Kentucky (DIBLASI, 1996), including wavy lines and chevron forms, associated with a ^{14}C determination of 3560 ± 110 bp. In 3rd Unnamed Cave, Tennessee (less than 100 km from Adair), a series of dates on charcoal fragments, recovered from hearths more than a kilometer underground, also indicates a Terminal

Archaic occupation; these fireplaces were made to illuminate flint-knapping activities exploiting a chert deposit in this deep cave context. On the ceiling above the knapping areas, a number of petroglyphs were incised, including a sun, chevrons, and other more enigmatic symbols. It should be noted that ceiling petroglyphs and chert mining coincide exactly in space within a cave more than 15 km long. In one place, chert debris and a fireplace even overlaid a petroglyph cut into a large breakdown slab on the floor, and a ^{14}C determination for the fireplace confirms the Terminal Archaic age of both the deposit and (by stratigraphic implication at least) the engraving. The sedimentary record suggests that the mining activity occurred over a very short period of time; only Terminal Archaic dates have come from the glyph and mining chamber. Thus, Archaic hunter-gatherers were the first to produce parietal art in Southeast caves, and at least some art production accompanied deep cave industrial activity, i.e., mining.

While the Woodland period has the greatest number of age determinations for cave *visitations* in the Eastern woodlands, only a handful of ^{14}C determinations indicate possible cave art for that phase. At Crumps Cave in Kentucky, DAVIS (1996) reports an elaborate group of mud glyphs cut into deep clay banks more than 1 km below the cave mouth. From inside an incised line composing one glyph, a piece of charcoal yielded a ^{14}C determination of 1980 ± 60 B.P. A torch stoke mark nearby has been aged to 1840 ± 80 B.P. Other Woodland period age determinations come from Mud Glyph, 2nd, 5th, 6th, and 25th unnamed caves in Tennessee and 19th Unnamed Cave in North Alabama. Three of these are burial caves, and 19th Unnamed Cave (while not containing burials itself) is within the Copena culture area partly defined based on burial in caves. These observations suggest, perhaps, a chronological dimension to mortuary use of cave art sites. In several possible Woodland burial caves, however, there are also Mississippian age determinations. Thus, while rare, cave art associations *do* exist with Woodland period age determinations.

The most frequent chronometric determinations link cave art with the Mississippian period. Within that period, a cluster of more than 30 ^{14}C determinations is evident between AD 1200 and AD 1350. In particular, mud glyph caves (1st Unnamed, 2nd Unnamed, and Mud Glyph caves in Tennessee, and Williams and Little Mountain caves in Virginia) have age determinations during this period; yet, as we have seen, even this form of cave art has its origins in the Archaic and Woodland periods. Nine Mississippian ages have been obtained from perhaps the most complex Southeastern cave art site of all, 11th Unnamed Cave in

Tennessee, where pictographs, engraved petroglyphs, and mud glyphs have all been found in association with other rather enigmatic dark zone activities including clay mining and human burial. Thus, the Mississippian period seems to be the culmination of Southeastern cave art production.

5. Meaning

We conclude with a few words about meaning in Southeastern cave art. This can most directly be approached for the Mississippian Period, where we know that relations between humans and the underworld were of great religious importance. We have found patterning in cave art from this period that suggests how ritual activity was associated with the art, defining a transformational ceremonial pathway from the human world into the dark world. We have also found that Mississippian decorated caves are one element in a regional artistic/iconographic landscape that comprised open-air rock art in high places and cave art in low ones, effectively mapping the cosmological landscape onto the natural world. The role cave art played earlier in times is more difficult to determine, although there are shared elements of design with fine ceramic decorations and other artifacts that were incorporated in ceremonial activities. What is clear is that, for more than 6,000 years, prehistoric peoples in the Southeast of North America visited and decorated the dark zones of caves, seeking therein sacred precincts, important resources, and religious edification. With nearly seventy sites now known, and more being found all the time, it is clear that the prehistoric Southeast was home to one of the world's few true great cave art traditions. It is an exciting prospect to discover and try to understand these important American cultural resources.

6. Note

* Because of potential vandalism, we use a numerical designation system rather than a cave's common or registered names; see SIMEK et al. (1997) for a description of this system.

Acknowledgments

The authors wish to thank The National Science Foundation, the Dogwood City Grotto, SERA, the Lucille S. Thompson Family Foundation, the National Geographic Society, the Tennessee Valley Authority, the Tennessee Historical Commission, and the University of Tennessee, for funding for the work described here.

References

DAVIS, D.B. (1996) *A Preliminary Report on the Mud Glyphs in 15Wa6, Warren County, Kentucky. Current Archaeological Research in Kentucky*

4:332–353. Frankfort: Kentucky Heritage Council.

DIBLASI, P.J. (1996) Prehistoric Expressions from the Central Kentucky Karst. In *Of Caves and Shell Mounds*, edited by Kenneth C. Carstens and Patty Jo Watson, pp 40–47. University of Alabama Press, Tuscaloosa, Ala.

FAULKNER, C.H. (Ed., 1986) *The Prehistoric Native American Art of Mud Glyph Cave*. University of Tennessee Press, Knoxville, Tenn.

SIMEK, J.F., A. CRESSLER, and J. DOUGLAS (In press) A New Overview of Prehistoric Cave Art in the Southeast. In *Ritual Uses of Caves*, Holley Moyes (Ed.), University of Colorado Press, Boulder Colo.

SIMEK, J.F., C.H. FAULKNER, S.R. FRANKENBERG, W.E. KLIPPEL, T.M. AHLMAN, N.P. HERRMANN, S.C. SHERWOOD, R.B. WALKER, W.M. WRIGHT, and R. YARNELL (1997) A Preliminary Report on the Archaeology of a New Mississippian Cave Art Site in East Tennessee. *Southeastern Archaeology* 16(1):51–73.

WATSON, P.J. (1986) Prehistoric Cavers of the Eastern Woodlands. In *The Prehistoric Native American Art of Mud Glyph Cave*, C.H. Faulkner (Ed.), University of Tennessee Press, Knoxville, pp 109–116.

**APPLICATION OF U-SERIES DATING METHOD TO FOSSIL BONES:
NEW PERSPECTIVES***GRZEGORZ SUJKA, HELENA HERCMAN**Institute of Geological Sciences, Polish Academy of Sciences, ul. Twarda 51/55, 00-818 Warszawa, Poland***Abstract**

During the last 40 years, fossil bones have been investigated repeatedly in order to determine the possibility of dating using the U-Th method. Bone accumulates uranium from infiltrating water during burial in sediments. This means that bone is an open system for uranium ions migration; it does not fulfill assumptions of the uranium-thorium geologic clock. Through the years, the main approach to this problem has been to construct the mathematical models to estimate the amount of accumulated uranium using statistical and mathematical simulations of accumulation process.

Bone is a biological material and as such is not a homogenous substance. It combines several organic and inorganic phases that react individually during fossilization and diagenesis. These processes also affect uranium accumulation process.

A similar problem was discovered for ^{14}C dating of fossil bones. Analysis revealed that the method of sample pretreatment affects the results of dating. Using simple chemical reactants and a controlled reaction environment, it is possible to decompose bone to its main components: carbonates, phosphates, lipids, proteins etc. Some of these bone-phases are less stable during diagenesis and degradation, so disequilibrium of the radiocarbon geologic clock occurs. For this reason, extracting the most resistant phase, which is a closed system for Carbon isotopes, is necessary. Now, standard procedure for the radiocarbon dating of fossil bones utilizes only the collagen acquired from bone samples through extraction and purification.

This study was (1) to estimate the potential of uranium (and thorium, if it occurs) accumulation in each of the bone-phases and (2) to verify suitability of fossil collagen for U-Th dating of fossil bones. Recent (whole-) bones and bone-phases were analyzed to define the starting point of the system. Next, a similar analysis of fossil bones of various ages and sites was performed. Comparing these two sets of data allows the mechanisms of the accumulation process to be determined. The study found three main conclusions: (a) There is no thorium accumulation in fossil bones; (b) Uranium accumulation potential is strictly connected with the chemistry of a phase and differs widely among main bone-phases. The chemistry of a phase determines the processes that take place during fossilization, diagenesis, and degradation; (c) The collagen phase has the least, if any, potential of uranium accumulation and may be a closed system for uranium and thorium isotopes migration.

Several preliminary U-Th and ^{14}C datings of the same sample of fossil collagen have been made. Unfortunately, the age of the sample is at the edge of the ^{14}C method's range, so the certainty of the comparison of these data is not fully satisfactory. However, acquired dates were not contradictory. More samples are being processed to provide a better test of the method.

THE IMPORTANCE OF KARST SITES AS PALEONTOLOGICAL LOCALITIES*RICKARD S. TOOMEY III**Mammoth Cave International Center for Science and Learning, WKU, 1906 College Heights Blvd #31066, Bowling Green, KY 42101-1066, USA, rick.toomey@wku.edu***Abstract**

Although they make up only a small percentage of paleontological sites worldwide, karst related sites are disproportionately important in many aspects of terrestrial vertebrate paleontology. This importance is related to several important aspects of karst-related paleontological deposits. These deposits typically preserve smaller taxa (small lizard and rodent-sized species) than do non-karst sites of the same age. These smaller taxa are often preserved more completely and with better preservation from karst sites; this is especially true in the case of cave and fissure sites. Karst sites also often preserve a higher diversity than non-karst sites.

Vertebrate fossil sites from karst settings are nearly as old as terrestrial vertebrates. One of the earliest terrestrial vertebrate site in the United States, a Mississippian age amphibian locality near Delta, Iowa, represents Mississippian karst deposits in a Devonian limestone. Paleokarst associated fossil vertebrate deposits occur in every geological period since the Mississippian. These deposits are often associated with diverse assemblages of rare small vertebrates. The Permian captorhinid sites from fissure fills in Oklahoma, the Triassic-Jurassic fissure fills from Wales and England, and the Neogene Riversleigh sites in Australia are just a few examples of karst associated fossil sites that are important because of the abundance, diversity, preservation, and taxonomic rarity of their fossils.

The important characteristics of cave and karst fossil sites are especially well represented in Quaternary mammal fossil sites. An analysis of over 2,600 sites from the FAUNMAP database of Quaternary mammal sites in the coterminous United States confirms the importance of karst sites and elucidates some of their general characteristics. Sites identified as caves comprise approximately 11% of these sites. However, these cave sites represent 14% of all analysis units and over 20% of all individual mammal taxon occurrences. Cave sites average approximately 12 taxa per site compared to only seven taxa per site for other types of sites. The importance of caves for paleoenvironmental interpretation using mammalian fossils is even more pronounced. Twenty-six percent of the occurrences of environmentally sensitive small mammals (Rodentia, Insectivora, Chiroptera, and Lagomorpha) in the research database are from cave sites. Perhaps more importantly, 74% of the mammalian occurrences from caves are from these taxa as compared to 53% of the occurrences from sites other than caves.

GRAFFITI IN THE MELIDONI CAVE IN CRETE, GREECE

YANNIS Z. TZIFOPOULOS¹, NIKOS LITINAS²¹*Aristotelian University of Thessaloniki, Faculty of Letters, Department of Classics
GR-54124 Thessaloniki, Greece, tzif@lit.auth.gr*²*University of Crete, Department of Philology, Rethymno 74100 Crete, Greece, litinas@phl.uoc.gr*

The graffiti, texts that were engraved or written on the walls of caves, are important, because they provide information about individuals who entered the caves, the dates of their visits, and specific areas of the cave they visited. Graffiti are found in all types of caves and in all continents, and they date to all periods, a fact that shows the tendency or need of humans to express certain thoughts or sentiments on the walls of these natural formations.

As regards the caves on the island of Crete, Greece, the graffiti were usually engraved on the exterior walls near the entry or in the first halls of the caves, and in a few cases on the interior walls. The Melidoni Cave (Gerontospilios or Gero-Spilios) lies 28 kilometers east-southeast of the city of Rethymno and another 1,800 m from the village Melidoni, at a height of 220 m on the southern slopes of Mt Kouloukonas in the lower Mylopotamos valley. The Cave has been attracting people since the late Neolithic period, and visits to the cave have started to appear from c. 100 BCE until today, that is for over 2100 years. The engravings follow more or less the same pattern - the name of the visitor, the date, and, in a few cases, the reason of the visit. Their study produced the following results. First, their number is approximately 3500. Most are found on the walls of the two main branches of the cave, and their documentation includes such details as position on the wall, size, paleographical details, date, transcription of text, and commentary. Second, the individuals who scratched or engraved on the interior walls of the cave may have been pilgrims because the results of the excavations by Yannis Tzedakis and Irene Gavrilaki suggest the cave constituted a religious center for worshipping a female deity from the Middle Minoan (ca 2160 BCE) until ca 500 BCE, and Hermes from ca 100 BCE. The pilgrims/visitors in antiquity respected the attempts of other people who entered the cave for the same reason as theirs, to worship. In later times, however, the cave became more or less a tourist attraction and the people who entered were interested more in engraving on the walls, wherever it was convenient, their own name as a memento, rather than in respecting earlier engravings. Those individuals who entered the cave and its remotest areas either as pilgrims or as visitors came from all over the world. Many engraved their names on the walls in various languages, such as Greek, Venetian, Arabic, Turkish, German, French and English. Many of these engravings correspond to specific important periods of the history of Crete, and they thus constitute a visitor's palimpsest book of Cretan history.

1. Introduction

The engravings, or texts on the walls of caves are important because they provide information about the individuals who approached and entered the caves, the dates of the visits, and the specific areas of the cave visited. Graffiti are found in all types of caves and in all continents, and they date to all periods, a fact that shows the tendency or the need of humans to express certain thoughts or sentiments on the walls of these natural formations. Albeit extremely significant, one can find only a few sporadic references or photos of this specific human activity in publications or presentations of caves, but no systematic scientific recording of graffiti on exterior or interior walls of caves.

As regards the caves on the island of Crete, Greece, there are many caves or caverns with engravings on their walls, most of which are usually engraved on the exterior walls near the entry or of the first rooms of the caves, and in a few cases on the walls of their interior. The cave of this presented here is the Melidoni Cave (Gerontospilios or Gero-Spilios), which lies twenty-eight kilometers E-SE of the city of Rethymno and another 1800m from the village Melidoni, at a height of 220m on the southern slopes of Mt. Kouloukonas in the lower Mylopotamos valley. The cave has been attracting people since the late Neolithic period, and visits to the Cave have started to appear from c. 100 BCE until today, that is for over 2100 years. Until 1998 only three inscriptions were known, engraved on the outer or the inner walls near

the entrance of the cave. In the last ten years the cave has been explored more systematically through archaeological excavations, which are ongoing under the direction of the archaeologist Irene Gavrilaki (Gavrilaki-Nikoloudaki 1988; Tzedakis and Gavrilaki-Nikoloudaki 1990; Godart and Tzedakis 1992; Tzedakis and Gavrilaki 1995; Gavrilaki 1996), and through the epigraphical survey (transcription, study, and commentary of the engravings found on the walls of the two main branches of the cave) which was entrusted to us.

A descent of 25 m from the entrance leads to the main chamber, the so-called “Heroes Room” (Fig. 1), named after the inhabitants who, pressed by the Turks in 1824, took shelter inside, and subsequently were suffocated when the Turks blocked the entrance and lit a fire (Fig. 2). This is the only area of the cave open to the public, and the graffiti on the walls of this room date to the 19th and 20th centuries. From this Room the cave is separated into two long branches, the longest of which extends eastwards and is closed to the public not only for security reasons, but also because of the ongoing archaeological and epigraphical research. After a small area (the “Raulin Room”), where no engravings have been found, and a descent of 3 m, the

“Pashley Room” is reached, named so after its first explorer. It is divided into three successively deeper areas by fallen stalactites and rockfall from the ceiling. The walls at the end of the first and second areas, at a depth of 40–42m from the entrance level, are covered by names of visitors and dated mostly to the Venetian period and onwards. After a very narrow corridor the third small area is reached at the depth of 53 m from the entrance level. It was named “Inscriptions/ Graffiti Room” because the graffiti and inscriptions on walls of the corridor and room are numerous and dated to the 1st century BCE and onwards. (The latest one was carved in 1998, the same year that this branch was closed for the public). From this area, a 5 m climb leads to the Room of Anna Petrocheilou, the legendary Greek speleologist who also explored and mapped the cave, where there seem to be no graffiti/inscriptions (Fig. 1). A 3 m descent leads to a very narrow precipice, where there are a number of graffiti dated to the Venetian and later periods.

The second branch of the cave runs NW of the Heroes Room, almost at a 90° turn from the eastern branch. This branch may be accessed by visitors but it is very difficult and extremely dangerous because of the uneven and slippery passage which leads to a circular area with the so called “Petrocheilos’

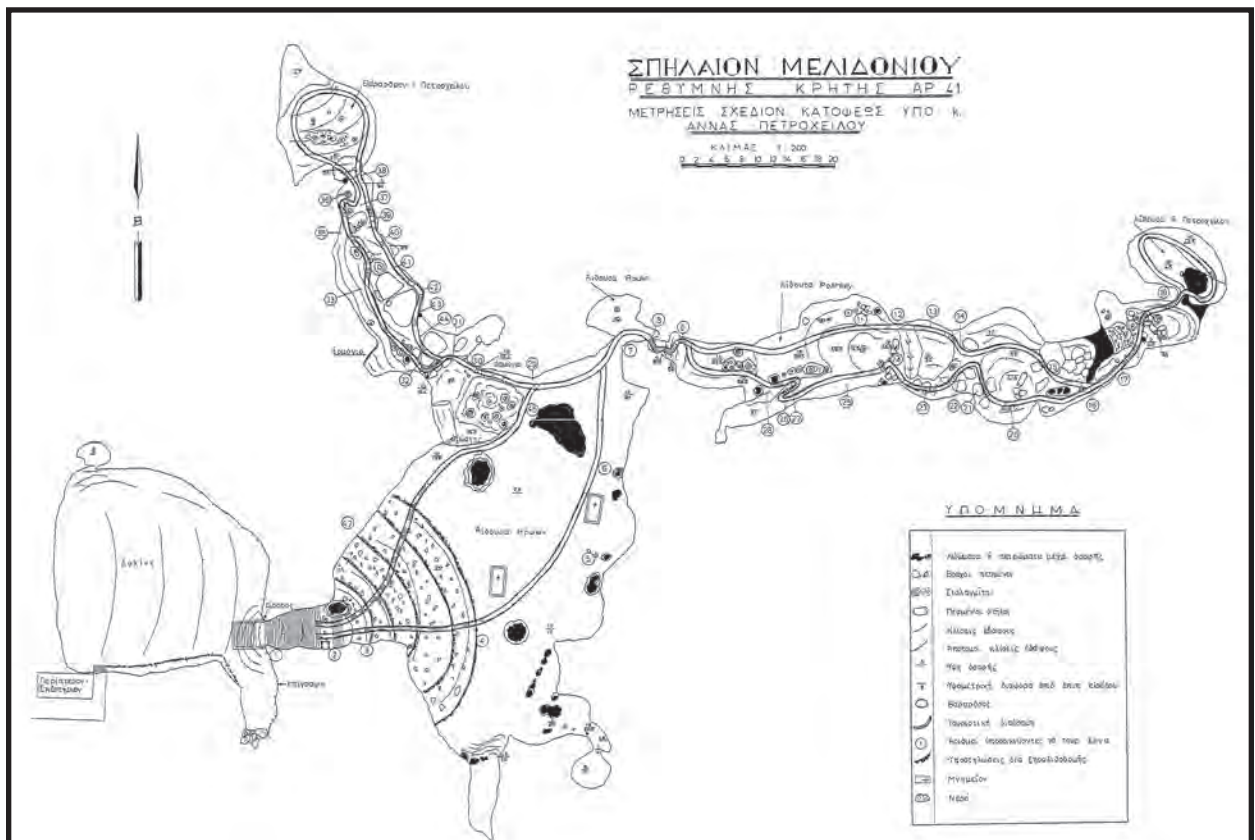

Figure 1: Map of the Melidoni Cave.



Figure 2: Entrance to the Melidoni Cave.

precipice,” a steep drop of 13 m (Fig. 1). On the walls and stalactites of this Room a number of graffiti/inscriptions are engraved, dated to the Venetian and later periods.

2. The Publication

The final publication of all the engravings, approximately 3500 which more or less follow the same pattern (name of visitor, date and, in a few cases, the reason of the visit), includes the following sections according to the epigraphical conventions used in scientific editions of inscriptions and graffiti.

Position on the wall and relation with engravings around it

Each wall is named and divided into smaller sections for easier identification; the division into sections basically follows the stalactite formations on the walls.

Measurements of the space occupied by the entire engraving on the wall

First the width and then the height in meters is given at their maximum values.

Paleographical details

These include: (a) Measurements of the letters and digits (maximum and minimum letter-height [LH] and digit-height [DH]); and (b) the way the text was carved (deep incision), scratched (light incision), or written (by pen, pencil, carbon, etc.).

Date

If a date is not included in the text, then a date is provided on the basis of paleographical and/or internal criteria.

Transcription of the text

The editorial signs employed are the following:

[αβγ]	letters restored in a lacuna
[...]	(ellipsis) established number of letters in a lacuna
()	resolution of abbreviations or symbols
{αβγ}	letters rejected by the editor
□αβγ□	letters deleted by the engraver
<αβγ>	letters added by the editor
...	(ellipsis) established number of unread letters
α β γ	letters which are doubtful or partially preserved
[---]	a number of letters lost in the lacuna
ABΓ	letters which are read, but which cannot be transcribed into known words
\αβγ/	letters inserted by the engraver above or below the line

Critical apparatus, where the transcribed text is explained by line number.

Translation, where necessary.

Commentary, where paleographical, linguistic, historical, and other relevant aspects of the text are discussed.

The few texts that follow provide an example of the methodology (the edition numbers are not final):

Edition no **5**. Inscription’s Room. East wall. Section I. First block of engravings. To the right of graffiti no **4**. Dimensions: 0.12 x 0.055; LH 0.01.5-0.023; DH 0.02. Carved and written with black pencil. Date: 1580

Transcription
180
Z/ ROSSO
Resolve Z(yan).



Edition no **6** (see image in ed. no **5**). Inscription’s Room. East wall. Section I. First block of engravings. Below graffiti no **5**. Dimensions: 0.13 x 0.06; LH 0.01.5-0.025. Carved and written with black pencil. At some points the black pencil does not follow the carving.

Date: 16th century (1580?)
Transcription
ZYAN B̄AR
BARIGO

The family name Barbarigo appears in some other graffiti in the cave.

Edition no **10**. Inscription’s Room. East wall. First block of engravings. Below graffiti no **9**. Dimensions: 0.165 x

0.04; LH 0.0280.032. Carved.
Date: 20th century

Transcription
Ε Ανδρουλιδακης



Resolve □Ε(μμανουήλ)? Between A and K there is a long stroke from the graffito above.

Edition no 14. Inscription's Room. East wall. Second block of engravings. Below graffito no 13. Dimensions: 0.12 x 0.045; LH 0.5-0.9 (l. 1), 0.015 (l. 3); DH 0.014. Written with black pencil.
Date: 1899

Transcription
A. VERDAGUER
1899
VIVE LA FRANCE



The same person also engraved his name in the Pashley Room (see graffito 450) and on the wall of the in the beginning of the Petrocheilos precipe, the remotest area of the east branch of the cave (see graffito no 2330).

Edition no 490. Pashley Room. East wall, opposite to the point 24 (map). Second block of engravings. Below graffito no 489. Dimensions: 0.07 x 0.10; LH 0.7-0.015; DH 0.01. Written with black pencil.

Date: 1973

Transcription
Three
Americans
d .. n
1973

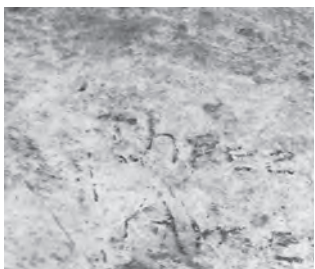

Line 3: the engraving is damaged and difficult to read.

3. Purpose of the Graffiti/Inscriptions

The individuals who scratched or engraved on the interior walls of the cave may have been pilgrims because the results of the excavations by Yannis Tzedakis and Irene Gavrilaki suggest the cave constituted a religious center for worshipping a female deity from the Middle Minoan (ca 2160 BCE) until

ca 500 BCE, and Hermes from ca 100 BCE. From the 1st century BCE humans who entered the cave felt the need, sometimes not without danger, to scratch their name with a sharp instrument mainly on the south wall of the Inscriptions Room, the innermost and deepest place of the cave, an activity which they described by using the Greek verb προσκυνῶ, denoting worship and perhaps a ritual (Dillon 1997; Elsner and Rutherford 2005; Lajtar 2006). The main tendency in antiquity was to engrave on a blank space of the walls, but in later times people wrote on top of the other engravings, in most of the cases destroying what was already engraved (fig. 2). This could be explained by the fact that the pilgrims/visitors in antiquity respected the attempts of other people who entered the cave for the same reason as theirs, to worship. In later times, however, the cave became more or less a tourist attraction and the people who entered were interested more in engraving on the walls, wherever it was convenient, their own name as a memento, rather than in respecting earlier engravings. Even so, there are a few examples which indicate that the cave did inspire sanctity and religiosity in later times as well: small cavities within the remote interior of the cave were changed by visitors into niches of some kind of worship. Those individuals, who entered the cave and its remotest areas either as pilgrims or as visitors, came from all over the world. Many engraved their names on the walls in various languages, such as Greek, Venetian, Arabic, Turkish, German, French and English. Many of these engravings correspond to specific and important periods of the history of Crete, and they thus constitute a visitor's palimpsest book of Cretan history.

Acknowledgements

We are indebted to Irene Gavrilaki, director of the Melidoni Cave excavations, for the collaboration and to the Ministry of Culture for permission to study the texts, for which see: Tzifopoulos forthcoming, and Tzifopoulos and Litinas forthcoming.

References

Dillon (1997) M. Dillon, *Pilgrims and Pilgrimage in Ancient Greece*, London/New York.

Elsner and Rutherford (2005) J. Elsner and I. Rutherford (eds), *Pilgrimage in Graeco-Roman and Early Christian Antiquity. Seeing the Gods*, Oxford.

Gavrilaki-Nikoloudaki (1988) Irene Gavrilaki-Nikoloudaki, "Αρχαιολογικές ειδήσεις 1987, Προϊστορικές και κλασικές αρχαιότητες, Νομός Ρεθύμνης, Μελιδόνι," *Κρητική Εστία* 2: 305–307.

- Gavrilaki (1994–96) Irene Gavrilaki, “Αρχαιολογικές ειδήσεις 1992-94, Νομός Ρεθύμνης, Μελιδόνη,” *Κρητική Εστία* 5: 291–293.
- Godart and Tzedakis (1992) L. Godart and Y. Tzedakis, *Témoignages archéologiques et épigraphiques en Crète occidentale du néolithique au minoen récent IIIB*, Incunabula Graeca 93, Roma.
- Lajtar (2006) A. Lajtar, *Deir el-Bahari in the Hellenistic and Roman Periods: A Study of an Egyptian Temple Based on Greek Sources*, Journal of Juristic Papyrology Supplement, Warsaw.
- Tzedakis and Gavrilaki-Nikoloudaki (1990) Y. Tzedakis and Irene Gavrilaki-Nikoloudaki, “Αρχαιολογικές ειδήσεις 1988, Νομός Ρεθύμνης, Μελιδόνη,” *Κρητική Εστία* 3: 273–275.
- Tzedakis and Gavrilaki (1995) Y. Tzedakis and Irene Gavrilaki, “Η ανασκαφή στο σπήλαιο Μελιδονίου.” *Πεπραγμένα του Ζ' Διεθνούς Κρητολογικού Συνεδρίου*, τόμ. Α2, Ρέθυμνο, 887-894, πιν. ρη' – ριγ'.
- Tzifopoulos forthcoming: Y.Z. Tzifopoulos, “Eleuthernaean Pilgrims inside the Melidoni Cave (*Tallaeum Antrum*),” forthcoming.
- Tzifopoulos and Litinas forthcoming: Y.Z. Tzifopoulos and N. Litinas, *The Melidoni Cave Inscriptions/Graffiti (Inscriptiones Creticae Tallaei Antri)*, forthcoming.

THE WORLD OF THE PAST IN THE WORLD UNDERGROUND

PATTY JO WATSON

*Washington University and University of Montana
2870 Solterra Lane, Missoula, MT 59803-1803 USA*

Cave interiors throughout the world have preserved paleontological and archaeological remains for thousands or hundreds of thousands of years. Most of these curatorial caves are wet, hence only hard tissues (e.g., bones and teeth), or artifacts of hard materials (bone and stone) survive. But there are also many dry caves where everything left—leaves, scales, feathers, wood, basketry, cordage, excrement, foot impressions—is beautifully preserved. Summary accounts from selected New and Old World caves, wet and dry, provide illustrative examples indicating past achievements and future projects for archaeologists and paleontologists who pursue research questions in the world underground.

1. Introduction

Paleontology and archaeology are sister sciences greatly benefiting from the physical characteristics of caves. The most important of these characteristics is the stable atmosphere of dark zone passages wherein temperature and humidity are constant, and there is virtual absence of weathering processes. The second obvious attribute of caves is that they have served as dens or shelters; places of refuge; sources of valuable materials such as fresh water, or salt and other minerals. Human groups have used caves and sinkholes as places to deposit their dead or as places to contact the spirit world and to obtain supernatural knowledge and power.

Examples of archaeological and paleontological research in a variety of cave habitats are presented. Because of my personal experience, these examples are weighted towards the USA, and towards archaeological rather than paleontological caves. I begin with three caves preserving significant paleontological as well as archaeological remains: Big Bone Cave and Jaguar Cave in Tennessee, USA, and Grotte Chauvet in the Ardeche region of France.

2. Paleontological/Archaeological Caves

Big Bone Cave (15.5 km long) was first noted in 1806 (CROTHERS, 1987, MATTHEWS, 2006:17–18, SMYRE and ZAWISLAK, 2007:17–21) and promptly exploited for its saltpeter deposits. During the 19th century mining of “peter dirt” (War of 1812, Civil War 1861–65) the skeletal remains of one or more giant ground sloths (*Megalonyx jeffersoni*) were discovered (MERCER, 1897; SMYRE and ZAWISLAK, 2007: 63–76, 225), and in 1970 cavers found the fragmentary remains of a now extinct form of jaguar (*Panthera onca*; GUILDAY and MCGINNIS, 1972; SMYRE and ZAWISLAK, 2007: 71–72).

Saltpeter miners and other early 19th century Euroamericans also reported materials left by ancient human activity in Big Bone Cave. More recently (1982) a small group of cavers found a complete open-twined weave drawstring bag (KUTRUFF, 1987), leading to full-scale investigation carried out by professional archaeologists in the mid-1980s (CROTHERS, 1987). Although saltpeter mining and other historic Euroamerican activities have disrupted and destroyed many earlier materials, the archaeologists found three cave passages where prehistoric remains were in good context. These remains include torch debris, human paleofecal deposits, and numerous artifacts such as cordage, basketry, moccasins woven from plant fiber, gourd or hard-shelled squash containers. Nine ¹⁴C dates were obtained on various items thought to be torch debris. One of these (pine wood) returned a date of 440 +/- 55 BP; all the others date between ~1600 to 3000 BP, the majority between 2100 and ~2400. Suggestions regarding prehistoric human activity in Big Bone Cave center upon removal of selenite crystals from the cave sediment.

Jaguar Cave (13 km long) is another Tennessee site with significant paleontological and archaeological remains. Two jaguar skeletons as well as jaguar claw and paw marks have been documented as well as the fragmentary bones of dire wolf, camel, peccary, and tracks (as well as a belly fur trail) left by a bobcat (WATSON et al., 2005). Dire wolf remains have been found in many other North American caves, this animal having been the most widespread Late Pleistocene carnivore in the Americas, extending from the U.S. to Peru. Remains of peccaries are also relatively common in North American caves, sometimes in sufficient numbers to indicate that they often traveled in groups. Peccaries are thought to have been important prey for jaguars like those of Jaguar and Big Bone caves.

All the non-human mammalian bone from Jaguar Cave dates to the Pleistocene (10–12,000 bp or earlier) and all bones except the jaguar skeletons come from a talus cone far back in the cave interior. This cone was the terminus of a pit that functioned as a natural trap for unwary animals traveling along the surface above. The jaguars are the same genus and species (*Panthera onca*) as that from Big Bone Cave.

About 4,500 years ago, Jaguar Cave was explored by nine people. They left 274 footprints in the soft mud of a passage ~1 km from the main entrance. The only other archaeological remains are torch smudges and a thin scatter of cane charcoal. This cave trip plus one into 48th Unnamed Cave, TN (ca. 4980 bp; CRESWELL, 2007), provide the earliest evidence for human exploration of deep-cave dark zones in the eastern US. There are much earlier dates (~14,300 bp) on human paleofecal material from the Paisley Caves in southern Oregon (GILBERT et al., 2008), but they are rockshelters rather than dark-zone caves. A true dark-zone cave in the Rocky Mountains of Colorado was entered by one man approximately 8000 years ago, however (MOSCH and WATSON, 1997).

Turning next to the painted caves of western Europe brings to mind not only the classic locales of Altamira, Lascaux, Niaux, etc, but also the more recent discoveries of Grotte Cosquer and Chauvet. The Mediterranean shoreline entrance to Cosquer is now drowned so only experienced divers can reach the chamber decorated by prehistoric artists ca. 27,000 years ago (COSQUER, 1992), but Chauvet is accessible to those with speleological gear (and entry permits.). Chauvet, like Cosquer, is a true dark-zone cave, but neither approaches the length or complexity of Big Bone, Jaguar, or archaeological caves in Kentucky and Central America (below). The distance from Chauvet's entrance to the end of the farthest room (Salle du Fond) is only about 250 m (CHAUVET et al., 1995: 14; THURMAN, 2008: 63). Cosquer, from drowned entry point to back wall of the decorated chamber, is comparable in length (COSQUER, 1992: 118).

The 32,000-year-old Chauvet wall paintings feature a wide array of species and artistic treatments: horses, bison, ibex, reindeer, an extinct elk-like herbivore (*Megaloceros*), lions, aurochs, cave bears, mammoths, and rhinoceroses (CHAUVET et al., 1995). There are also geometric markings (one room is called the "Gallery of Crosshatches") and renderings--both positive and negative--of human hands as well as a few representations of male and female genitalia. These remarkable paintings have attracted most of the

public's attention, but there are also thousands of cave bear bones (*Ursus spelaeus*) in Chauvet. Mitochondrial DNA was recently obtained from one of these cave bears (a sternum from the Crosshatch Gallery AMS dated to 31,870 + 300/-270; BON et al., 2008). Comparative study indicates that European cave bears are a sister taxon to European brown bears and to polar bears, ancestral brown and polar bears having diverged from cave bears early in the Pleistocene (~1.6 million years ago). Although *Ursus spelaeus* is known only from England east to the Caspian Sea region, there was a distant relative (*Tremarctos floridanus*) making use of caves in the southeastern US (e.g., GUILDAY and MCGINNIS, 1972 refer to a *T. floridanus* skeleton found in Grassy Cove Saltpeter Cave, TN), and surviving into the Holocene in Florida. It is thought that both Old and New World cave bears relied on caves as hibernation locales (KOWALSKI, 2005).

Other European paleontological-archaeological caves in the news at present are three sites within the mountain of Atapuerca in northern Spain: Gran Dolina (no longer a cave but rather 18 m of cave sediments exposed by excavation of a railway trench ca. 1900), Sima de los Huesos, and Sima del Elefante. All have yielded human bones, as well as those of non-human animals. A recently recovered human jaw fragment from the Elefante pit dates 1.2-1.1 million years ago, currently the earliest evidence for *Homo* sp. in Europe (AGUSTI and ANTÓN, 2002: 258-259; CARBONELL et al., 2008; KLEIN, 2005: 108–110).

3. Paleontological Caves

Early research (19th-mid 20th century) in cave paleontology was focused primarily on remains of large animals like those already noted for Big Bone, Jaguar, and Chauvet. Realization that small animals are much more sensitive to and hence more informative about local environments synchronically and diachronically than are large far-ranging carnivores and herbivores, together with technological improvements such as the Scanning Electron Microscope have resulted in far greater attention to microfauna. The work of Peter Andrews and his colleagues at Westbury-sub-Mendip (ANDREWS, 1990) is an excellent example. The cave as such no longer exists, but the sediment-filled passages, intersected during a quarrying operation, were carefully excavated by the paleontological team. Abundant remains of a Mid-Pleistocene microfaunal assemblage--voles, mice, shrews, rabbits, lemmings, as well as birds, amphibians, and reptiles--were recovered, most of which had originally been accumulated in or near the cave by various kinds of owls.

Vertical shafts or sinkholes, like that intersecting a horizontal

passage in Jaguar Cave, often act as natural traps for animals of all sizes. Natural Trap Cave in Wyoming (MARTIN and GILBERT, 1978) is a classic example. The cave is a 20 m deep pit with a narrow surface opening that bells out below forming a chamber shaped like an upside-down funnel. Animals (e.g. horse, American cheetah, shortfaced bear; KURTÈN and ANDERSON, 1980) surviving the fall to the pit floor cannot climb the overhanging walls back to the surface.

4. Archaeological Caves

The prehistoric archaeological record within dark-zone caves sometimes includes human skeletons, or parts of them, or desiccated bodies as well as other evidence of past human activity. The latter includes torch fragments, torch smudges, hearth areas, artifacts of perishable and non-perishable materials, quarrying of cave sediments, footprints. For millions of years ancestral humans and their descendants made use of rockshelters, cave entrances, and--at least since the Late Pleistocene--dark-zone cave interiors as well. I provide several prehistoric examples before concluding with reference to a few dark-zone caves preserving the remains of significant recent historical events.

4. 1 Some Ritual Caves in the Americas

Cave ritual is still important in many parts of the Central American karst. J. Eric S. THOMPSON (1975, ix) remarks that the Lowland Maya, for example, have been speleologists for the past 2,700 to 3,000 years owing to the fact that their land is bereft of surface water but rich in sinkholes and caves where permanent water can be found. He lists other ways in which the contemporary and ancient Maya use caves, nearly all having to do with religious ceremonies. Virgin water dripping from cave ceilings, walls, and speleothems is required for various religious rituals, some of which are performed in cave rooms. Caves are also very important for mortuary purposes, which often include deposition of grave goods and other ceremonial materials (e.g. STEELE and SNAVELY, 1997). Despite the fact that important archaeological materials have long been known to be present in Mayan caves and cenotes (MERCER, 1896; STEPHENS, 1843; THOMPSON, 1897), systematic and sustained archaeological research on the Maya underground was not begun until the 1980s when James Brady undertook a study of Naj Tunich for his dissertation research. He and several other Mesoamericanist scholars now form a robust community of speleoarchaeologists (e.g. PRUFER and BRADY, 2005; BRADY and PRUFER, 2005).

Beginning about the same time as Brady was starting his work at Naj Tunich, archaeologist Charles Faulkner at the

University of Tennessee, together with a team of cavers and cave photographers, was documenting a very different kind of ritual cave (FAULKNER, 1986, 2008). Mud Glyph Cave comprises a 96 m long dark-zone passage displaying dozens of curvilinear, rectilinear, and zoomorphic images incised in damp mud covering the cave walls. Radiocarbon determinations indicate an age of 500 to 700 years for the images.

Subsequent to the Mud Glyph project, Faulkner's colleague, Jan Simek, formed a research group consisting of cavers, caving organizations, and archaeologists who are systematically surveying all known Tennessee caves for archaeological remains (SIMEK, 2008). Some 250 of the 1000 caves examined so far retain prehistoric remains: 62 of these were burial sites, 47 contain cave art (i.e., pictographs and/or petroglyphs; see SIMEK and CRESSLER, 2008, 2009), but only 14 had been mined for cave minerals.

During the 1990s, another group of archaeologists, cavers, and avocational rock art specialists began work at a decorated cave in Missouri whose artwork was created approximately a millennium ago (DIAZ-GRANADOS, 2008). The painstaking research of Diaz-Granados and her team at Picture Cave--like that of Faulkner, Simek, and their collaborators--sets high standards for documentation and interpretation of prehistoric ritual caves in the midcontinental and southeastern US, or elsewhere.

So we now know that several caves in Eastern North America were sacred spaces. There is also slowly accumulating evidence indicating that caves previously thought to have been simply mineral quarries were a good bit more than that. I am referring to parts of Salts Cave and Mammoth Cave, portions of the world's longest cave system (WATSON, 1974). The people who left archaeological remains throughout many miles of this system between 4000 and 2000 years ago were the best cavers anywhere prior to the early 20th century AD. Some of their underground activities may have been primarily exploration, and certainly many of them were intent upon obtaining gypsum powder and crystals (and probably mirabilite as well), which could have been used for secular purposes, but which are beginning to look more like very special materials from a very special place (see also BARRIER and BYRD, 2008; PRITCHARD, 2008). Salts Cave and Mammoth Cave probably were, at least for some prehistoric cavers, ritual locales. There are petroglyphs and charcoal pictographs in both caves, but the images are often small and partially obscured by historic traffic and graffiti. CROTHERS (during the Mammoth Cultural Resource Survey, 1992

to 2004), DIBLASI (1996), and others have documented several examples. These are important additions to knowledge of Salts and Mammoth dark-zone archaeology, but even more significant is the distributional patterning of prehistoric archaeological remains in the several kilometers of Mammoth Cave's main trunk passages intensively surveyed between 1992 and 2004 (see CROTHERS, 2001 for a preliminary summary). Thanks to laser transits, dataloggers, and computer software such as GIS programs, the Mammoth Cave survey has revealed significant correlations between, for example, concentrations of naturally-forming mirabilite and densities of prehistoric remains (including human paleofecal deposits). Survey data also document the systematic intensity of gypsum crust mining, thought to have been socially and ideologically sustained through multiple generations of ancient miners.

4. 2 Caves Preserving Recent Historic Archaeological Remains

Floyd Collins' death in Sand Cave, Kentucky, in 1925 was very well-publicized. The event has been kept in public view ever since by cave historians (MURRAY and BRUCKER, 1979), novelists (WARREN, 1959), radio and TV interviewers, screenwriters (a 1950 movie "Ace in the Hole" starring Kirk Douglas and Jan Sterling), and playwrights ("Of Time and the Rock," a July 1981 Horse Cave Theater presentation for the International Speleological Congress, Bowling Green, KY). Most recently (April 2008), "Floyd Collins: The Musical" (Tina Landau and Adam Guettel, based on MURRAY and BRUCKER, 1979) was staged at the University of Arkansas.

George CROTHERS (1983) surveyed and recorded both prehistoric remains and historic materials left from the Collins rescue attempts in and around Sand Cave. The cave is now within the boundaries of Mammoth Cave National Park, and hence is a federally protected site. Crothers' work there is an excellent example of historical archaeology in a particularly difficult cave consisting of low, wet crawlways (mostly belly crawls) in breakdown piles.

Also within a context of human tragedy are the European caves where civilian groups took refuge during World War II. The caves and limestone quarries of Caen in northern France have been in the news recently (November 2008, Associated Press story by John LEICESTER) as a result of efforts by an avocational archaeologist (Laurent Dujardin), in collaboration with a photographer (Damien Butaeye), to document the ordeal of some 20,000 Caen citizens. These people took refuge in 12 of the quarries during intensive bombing of German defenses near Caen by Allied planes

beginning on D-Day (June 6, 1944). A staff member (Stephane Simonnet) at the Caen war museum is quoted as saying "You have the feeling that people were still there 24 hours beforehand and, most important, [the artifactual remains have] never been manipulated, picked up, moved..."

The last example is the subject of a recent book, *The Secret of Priest's Grotto: A Holocaust Survival Story* (TAYLOR and NICOLA, 2007). The authors record events in two Ukrainian villages after the 1941 German invasion when several Jewish families took refuge in a nearby commercial cave. They were found by the Germans, however, and those who survived the raid eventually made their way to another, much larger cave (now ranked 12th longest on the world list) Popowa Yama, Priest's Grotto, where they lived 370 m inside the dark zone until Russian troops liberated the area in 1944. Like the Caen quarry cave, Priest's Grotto has preserved the World War II subterranean camp virtually intact.

5. Concluding Remarks

This brief overview indicates only a tiny fraction of what has been learned to date, let alone what may be learned in the future, although it is obvious that digital recording and analyses as well as micromorphological studies of cave sediments (GOLDBERG and SHERWOOD, 2006) will play major roles as will DNA analyses. I hope this modest summary has at least reminded readers of the rewards awaiting those who follow ancient human and non-human creatures into that subterranean universe preserving remains of past worlds infinitely fascinating in their immediacy, their complexity, and the compelling narratives inherent in each evidential component.

References

- AGUSTI, J., and M. ANTÓN (2002) *Mammoths, Sabertooths, and Hominids*. Columbia University Press, New York, USA, 313 pp.
- ANDREWS, P. (1990) *Owls, Caves and Fossils*. University of Chicago Press, Chicago, IL, USA, 231 pp.
- BARRIER, C., and M. BYRD (2008) Gypsum mining at Indian Salts Cave: an examination of Early Woodland subterranean mineral extraction. Chap. 4 in *Cave Archaeology of the Eastern Woodlands*, D. Dye (Ed.), University of Tennessee Press, Knoxville, TN, USA, pp 79–95.
- BON, C., N. CAUDY, M. DE DIEULEVEULT, P. FOSSE, M. PHILLIPE, F. MAKSUD, È.

- BERAUD-COLOMB, E. BOUZAID, R. KEFI, C. LAUGIER, B. ROUSSEAU, D. CASANE, J. VAN DER PLICHT, and J-M. ELALOUF (2008) Deciphering the complete mitochondrial genome and phylogeny of the extinct cave bear in the Paleolithic painted cave of Chauvet. *Proceedings of the National Academy of Sciences* **105**, 17447–17452.
- BRADY, J., and K. PRUFER (Eds.) (2005) *In the Maw of the Earth Monster: Mesoamerican Ritual Cave Use*. University of Texas Press, Austin, TX, USA, 438 pp.
- CARBONELL, E., J. BERMÚDEZ DE CASTRO, J. PARÉS, A. PÉREZ-GONZÁLEZ, G. CUENCA-BESCÓS, A. OLLÉ, M. MOSQUERA, R. HUGUET, J. VAN DER MADE, A. ROSAS, R. SALA, J. VALLVERDÚ, N. GARCÍA, D. GRANGER, M. MARTINÓN-TORRES, X. RODRÍGUEZ, G. STOCK, J. VERGÈS, E. ALLUÉ, F. BURJACHS, I. CÁCERES, A. CANALS, A. BENITO, C. DíEZ, M. LOZANO, A. MATEOS, M. NAVAZO, J. RODRÍGUEZ, J. ROSELL, and J. ARSUAGA (2008) The first hominin of Europe. *Nature* **452** (27 March 2008), 465–469.
- CHAUVET, J-M, E. DESCHAMPS, and C. HILLAIRE (1995) *La Grotte Chauvet à Vallon Pont-D'Arc*. Seuil, Paris, 119 pp.
- COSQUER, H. (1992) *La Grotte Cosquer*. Solar, Paris, 120 pp.
- CRESWELL, B. (2007) Phase I archaeological survey of caves and rockshelters within the proposed corridor of the Knoxville Parkway (SR 475) in Anderson, Knox, and Loudon Counties, Tennessee. Archaeological Research Laboratory, Univ. of Tennessee, Knoxville, Tennessee Dept. of Transportation Project #98012-1264-04, 72 pp.
- CROTHERS, G. (1983) Archaeological investigations in Sand Cave, Kentucky. *National Speleological Society Bulletin* **45**, 19–33.
- CROTHERS, G. (1987) An archaeological survey of Big Bone Cave, Tennessee, and diachronic patterns of cave utilization in the Eastern Woodlands. MA thesis, University of Tennessee, Knoxville, USA, 98 pp.
- CROTHERS, G. (2001) Mineral mining and perishable remains in Mammoth Cave: examining social process in the Early Woodland period. Chap. 18 in *Fleeting Identities: Perishable Material Culture in Archaeological Research*, P. Drooker (Ed.), Center for Archaeological Investigations Paper 28, Southern Illinois University Press, Carbondale, IL, USA, pp 314–334.
- DIAZ-GRANADOS, C. (2008) Picture Cave: the study, dating, and gating of a rare prehistoric American Indian site. Chap. 12 in *Cave Archaeology of the Eastern Woodlands*, D. Dye (Ed.), University of Tennessee Press, Knoxville, TN, USA, pp 203–215.
- DIBLASI, P. (1996) Prehistoric expressions from the Central Kentucky Karst. Chap. 5 in *Of Caves and Shell Mounds*, K. CARSTENS and P. WATSON (Eds.), University of Alabama Press, Tuscaloosa, AL, USA, pp 40–47.
- FAULKNER, C. (Ed.) (1986) *The Prehistoric Native American Art of Mud Glyph Cave*. University of Tennessee Press, Knoxville, TN, USA, 126 pp.
- FAULKNER, C. (2008) Cavers and archaeologists: the study of Mud Glyph Cave. Chap. 11 in *Cave Archaeology of the Eastern Woodlands*, D. Dye (Ed.), University of Tennessee Press, Knoxville, TN, USA, pp 193–201.
- GILBERT, M., D. JENKINS, A. GÖTHERSTROM, N. NAVERAN, J. SANCHEZ, M. HOFREITER, P. THOMSEN, J. BINLADEN, T. HIGHAM, R. YOHE II, R. PARR, L. CUMMINGS, and E. WILLERSLEV (2008) DNA from pre-Clovis human coprolites in Oregon, North America. *SCIENCEEXPRESS* 3 April 2008/pp 1–4/10.1126/science.1154116.
- GOLDBERG, P., and S. SHERWOOD (2006) Deciphering human prehistory through the geoarchaeological study of cave sediments. *Evolutionary Anthropology* **15**, 20–36.
- GUILDAY, J., and H. MCGINNIS (1972) Jaguar (*Panthera onca*) remains from Big Bone Cave, Tennessee and east central North America. *National Speleological Society Bulletin* **34**, 1–14.
- KLEIN, R. (2005) Hominin dispersals in the Old World.

- Chap. 3 in *The Human Past*, C. SCARRE (Ed.), Thames & Hudson, London, pp 84–123.
- KOWALSKI, K. (2005) Paleontology of caves: Pleistocene mammals. In *Encyclopedia of Caves*, D. Culver and W. White (Eds.), Elsevier Academic Press, New York, USA, pp 431–435.
- KURTÈN, B., and E. ANDERSON (1980) *Pleistocene Mammals of North America*. Columbia University Press, New York, USA, 443 pp.
- KUTRUFF, J. (1987) A prehistoric twined bag from Big Bone Cave, Tennessee: manufacture, repair, and use. *Ars Textrina* 8, 125–153.
- MARTIN, L., and B. GILBERT (1978) Excavation at Natural Trap Cave. *Transactions of the Nebraska Academy of Sciences* 6, 107–116.
- MATTHEWS, L. (2006) *Big Bone Cave*. National Speleological Society, Huntsville, AL, USA, 220 pp.
- MERCER, H. (1896) *The Hill-Caves of Yucatan*. J.B. Lippincott, Philadelphia, PA, USA, 183 pp.
- MERCER, H. (1897) The finding of the remains of the fossil sloth at Big Bone Cave, Tennessee, in 1896. *American Naturalist* 30, 608–611.
- MOSCH, C., and P. WATSON (1997) An ancient Rocky Mountain caver. *Journal of Cave and Karst Sciences* 59, 10–14.
- MURRAY, J., and R. BRUCKER (1979) *Trapped!* GP Putnam's Sons, New York, USA, 335 p.
- PRITCHARD, E. (2008) Deep cave mining: archaeological and GIS investigations of a prehistoric gypsum mine at Hubbards Cave. Chap. 5 in *Cave Archaeology of the Eastern Woodlands*, D. Dye (Ed.), University of Tennessee Press, Knoxville, TN, USA, pp 97–116.
- PRUFER, K., and J. BRADY (Eds.) (2005) *Stone Houses and Earth Lords: Maya Religion in the Cave Context*. University of Colorado Press, Boulder, CO, USA, 392 pp.
- SIMEK, J. (2008) Afterword. In *Cave Archaeology of the Eastern Woodlands*, D. DYE (Ed.), University of Tennessee Press, Knoxville, TN, USA, pp 261–270.
- SIMEK, J., and A. CRESSLER (2008) On the backs of serpents: prehistoric cave art in the southeastern woodlands. Chap. 10 in *Cave Archaeology of the Eastern Woodlands*, D. Dye (Ed.), University of Tennessee Press, Knoxville, TN, USA, pp 169–192.
- SIMEK, J., and A. CRESSLER (2009) Prehistoric cave art in southeastern North America. This volume.
- SMYRE, J., and R. ZAWISLAK (2006) *Big Bone and the Caves of Bone Cave Mountain*. Rocky River Press, Rock Island, TN, USA, 248 pp.
- STEELE, J., and R. SNAVELY (1997) Cueva Cheve tablet. *Journal of Cave and Karst Studies* 59, 26–32.
- STEPHENS, J. (1843) *Incidents of Travel in Yucatan*. Harper Publishing, New York, USA, 2 vols., 669 pp.
- TAYLOR, P., and C. NICOLA (2007) *The Secret of Priest's Grotto*. Kar-Ben Publishing, Minneapolis, MN, USA 64 pp.
- THOMPSON, E. (1897) Cave of Loltun, Yucatan. *Memoirs of the Peabody Museum, Harvard University* 1 (2).
- THOMPSON, J. (1975) Introduction to reprint edition of Mercer 1896. Zephyrus Press, Tea Neck, NJ, USA, vii–xliv.
- THURMAN, J. (2008) Letter from southern France: first impressions. *The New Yorker*, June 23, 2008, 59–67.
- WARREN, R. (1959) *The Cave*. Random House, New York, USA, 403 pp.
- WATSON, P. (Ed.) (1974) *Archeology of the Mammoth Cave Area*. Academic Press, New York, 255 pp.
- WATSON, P., M. KENNEDY, P. WILLEY, L. ROBBINS, and R. WILSON (2005) Prehistoric footprints in Jaguar Cave, Tennessee. *Journal of Field Archaeology* 30, 25–43.

ARCHAEOLOGY IN BRAZILIAN CAVES

LEANDRO A. F. XAVIER and DIVALDO R. SAMPAIO

*Paralelo 20 Consultoria e Projetos em Meio Ambiente Ltda.**Germano Torres, St. 166/504. Cruzeiro. Belo Horizonte. MG. 30.310-040 Brazil**paralelo20consultoria@gmail.com*

This work presents a general perspective about the chronological and cultural contexts associated with Brazilian caves and cavern environments. Brazil, a country in the South Hemisphere, is internally divided in five main regions, and all present excellent natural contexts for cave development. Countless archaeological systematic studies were made in caves and shelters, mainly because of their excellently preserved archaeological vestiges. The obtained data was fundamental to establishing a chronological view of human occupation in Brazil, which has been researched by naturalists, collectors, and archaeologists since the 19th Century.

1. Introduction

It is difficult to summarize the history of Brazilian archaeology in one paper, mainly because these studies are entwined with both the use and exploration of caves. In the first prospectus, made by Peter Wilhelm Lund in 1834, the number and variety of caves reported in Brazil are remarkable. Lund researched more than 800 grottos in just 10 years (1834 – 1844). The database of IPHAN (Instituto do Patrimônio Histórico e Artístico Nacional: <http://www.iphan.gov.br>), the Brazilian official organization that inspects and preserves the cultural and archaeological heritage, provides the following datum: 35% (4200 sites) of the estimated 12,000 registered archaeological sites are in cavern environments. This datum demonstrates the significance of this environment in the preservation of human records as climatic, sedimentological, and fossil records providing researchers with quality data. In this work, we recognize the outstanding importance of these environments to Brazilian's archaeology, presenting the natural and cultural contexts of these sites in cavern contexts.

2. Brazilian Natural Contexts

Brazil, a South American country, is politically organized in five main regions and 23 states. There are six main biomes: Amazon forest, *cerrado* (savanna), *caatinga*, Atlantic forest, *pantanal* (wetland), and *pampa*. To present our data we will use both divisions (Fig. 1).

Amazon forest is located in northern and northeastern sectors of Brazil and some neighbor countries (GUERRA et al., 2007) and characterized by large-sized native forest (over 40, high) and by the world's biggest hydrographic basin, containing the Amazon River – world's biggest river - 6992 km long, which rises in the

Andes and flows in the Atlantic Ocean.

Cerrado (Brazilian's savanna) is the main biome in the center of the country, with spaced out small-sized shrubs. Its formation is in open-fields, with herbaceous vegetation, rarely over 10 m high, and has a seasonal tropical climate, alternating between 40° C and 10° C.

Caatinga is a Brazilian's exclusive biome. It is characterized by a semideciduous forest adapted to an extreme arid environment, annual rains under 800 mm, and high temperature, up to 50° C. The vegetation is composed mostly of cacti and tortuous-trunk/large-top species, like cashew (*Anacardium occidentale*).

Atlantic forest is named because it receives moisture from the Atlantic Ocean. It's a tropical rain forest, with large-size vegetation (over 30 m) and a large number of flora and fauna species. It occupies Brazilian territory in a north-to-south direction and, at the coast, reaches high altitudes. It depends of constant humidity for its development and maintenance.

Pantanal (Brazilian's wetland) is a large sedimentary lowlands, and more than 45% of its floodplains are submerged (increasing to 80% in the rainy season), forming temporary lagoons. The vegetation resembles the *Cerrado* biome.

Pampa is a temperate biome, with wet grass vegetation and the rare occurrence of trees. It's the Brazilian's lower temperature biome, reaching -9° C.

The archaeological main contexts in Brazil are speleological contexts as well. With fabulous sedimentary formations, from Mesoproterozoic (1600 Ma) to Mesozoic (65

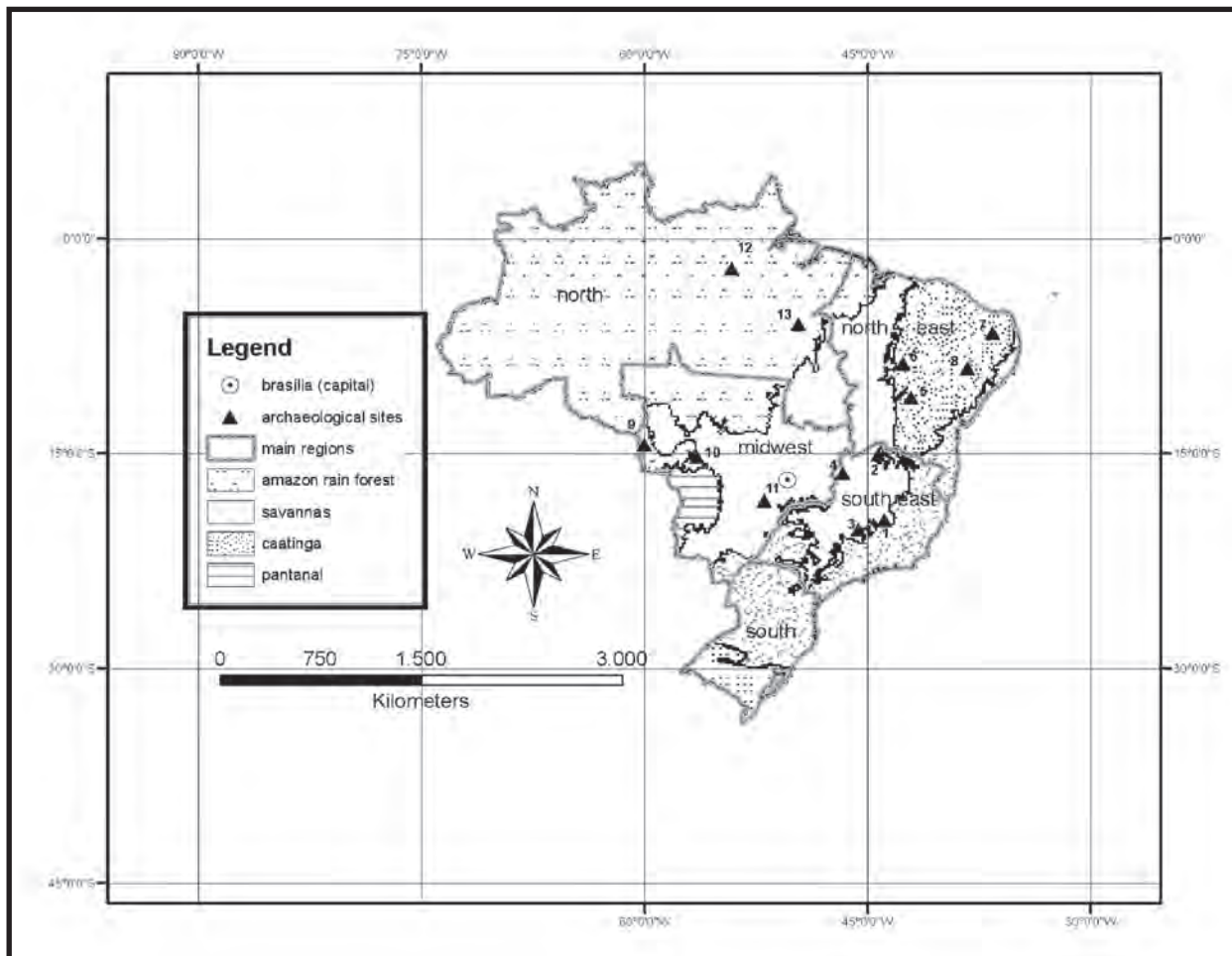

Figure 1: Brazil: Political divisions, natural domains and archaeological sites.

Ma), Brazilian landscapes provide a lot of places for human settlement and for rock art expression. Although humans have not lived inside the caves, there is an intense relationship between men and caves. Most contexts are located in karst environments spanning a large number of soluble rocks, forming caves and caverns which preserve evidence of the erosional events, including human vestiges. However, as Brazil is a large and diverse country, we shall present archaeological contexts in carbonate caves as well as caves in quartzite, as *canga ferrifera*, where the cavern formation is considered rare and is still being studied.

3. Brazilian Cultural Contexts

We have defined three periods of archaeological evidence, according PROUS (1992): period (which dates before 12,000 BP), archaic period or hunter-gatherer period (which dates between 12,000 and 3,000–2,000 BP), and formative period or horticulturist-ceramic period (which dates from 3000 BP until the contact with the Portuguese

colonizers: 1500 B.C.).

Within the Pleistocenic period, there are discoveries in Minas Gerais, Rio Grande do Sul, São Paulo, and Bahia. The dates range from 14,000 to a controversial 300,000 BP! The reliability problems of these dates come from insufficient ¹⁴C samples to insecure associations with dated megafauna deposits. The accepted dates do not go further than 15,000 BP. The cultural material is composed of very simple knapped stone tools.

The archaic period sites are spread in all parts of Brazil, and to summarize this period would exceed the limits (and subject) of this article. We mention, as notable data:

- the southern cultures (Humaitá and Umbu – from Rio Grande do Sul and Paraná), composed of choppers, chopping tools, bifacial artifacts, and arrowheads;

- *sambaquis* (shell piles) from the Brazilian coast (mainly São Paulo and Paraná), which includes shell and bone tools and stone tools assemblages;
- *Cerritos* (sedimentary platforms) from Rio Grande do Sul, with a lithic industry based on simple knapped pebbles;
- the *Itaparica tradition*, which is spread over the Brazilian Highlands (eight states), where we recognize an artifact known as *lesma* (slug), a versatile flat-convex scraper, which defines this culture (the absence of arrowheads is another characteristic of these groups);
- the northeastern cultures, especially in Piauí and Pernambuco, are characterized by scrapers, pebbles and arrowheads (bifacially retouched fragments suggest their presence).

Within the formative period, human groups settled in villages and camps in the main Brazilian fluvial valleys. It is assumed that, from hunter-gatherer transition, the use of pottery and the cultivation of some vegetables become a constant practice. The domain of territories and the exchange of manufacturing styles were studied by many archaeologists (PROUS, 1992; PROUS and SCHLOBACH, 1997)

Over 30 years of archaeological research in Brazil, the various settling systems, pottery manufacturing styles, burial and lithic industries were observed. Various groups colonized Brazilian territory, but we will concentrate our attention on *Una* culture – ceramic tradition that used and occupy cavern environments. Spread-over all of Brazil, with their focus in the Central region, the *Una* groups have explored the caves for their use and for burials and, according to some authors (HENRIQUES, 2006; WÜST, 1992; and DIAS and CARVALHO, 1983), their origins ascend from hunter-gatherer groups, according to observations from stratigraphic sequences without discordance or interruption. The lithic industry associated with *Una* occupation does not present sudden modifications, just adaptations and the introduction of polished artifacts. The dates for *Una* occupations (over areas 2, 3, 4, 5, 6, 7, 11, and 12 of figure 1) are about 3500 BP (Precise date: 3490 BP - PROUS, 1992: 334).

4. Rock Art

Rock art was noted in Brazil since 16th Century, by European colonizers. There were notes, for example, in the 19th Century concerning voyagers' descriptions. The systematic surveys began in 1960 and an enormous increase occurred over the next decade, before recent research.

PROUS (1992) relates eight traditions or regions of rock art. Some dating studies of them have been made: to northeastern, GUIDÓN (PROUS, 1992) has found dates from 2000 to 7000 BP. PESSIS (PROUS, 1992) has found 7000, 9000, up to 15,000 BP! Pigments and ink preparation artifacts dated between 3500 and 12,000 BP, in archaeological layers within sites in Minas Gerais. The most reliable dates are about 3950 and 4400 BP.

5. Brazilian Cavern Environments and Archaeological Vestiges

The most important areas of archaeological vestiges in cavern environments are recognized by political divisions.

5.1. Southeastern region

This region contains one of the highest concentrations of sites in cavern environments (more than 800), located in karst areas of the Grupo Bambuí carbonate rocks (from Neoproterozoic, Cryogenian [850 – 650 Ma] according to COMIG and CPRM (2003).

Area 1 – Lagoa Santa / Serra do Cipó: located in the transition between *Cerrado*/Atlantic forest, it has been studied since the 19th Century. The main sites are Lapa Mortuária de Confins, Cerca Grande, Lapa Vermelha IV, and Grande Abrigo de Santana do Riacho. Mostly characterized by the presence of paleontological material, laid down in levels two meters below, usually superimposed by stalagmitic layers dividing Pleistocene and Holocene periods. Lapa Vermelha IV, site chosen as a reference, presents the best depositional context of a human skeleton associated with Pleistocene sediments. Below a 12,960 BP dated layer was the intact skull of *Luzia* – the oldest hunter-gatherer representative of Lagoa Santa. The site presents dates between 25,000 and 1050 BP. In Grande Abrigo de Santana do Riacho, 50 km distant, 12 burials dating between about 18,000 and 9560 BP, were found organized between the big blocks fallen from the cavern roof. This site has *Una* ceramic occupations.

Area 2 – Alto Médio Rio São Francisco: this area has a huge outcrop surface of Grupo Bambuí limestone, divided by the São Francisco River, one of the biggest Brazilian rivers. In the limestone canyon of one of its tributaries, Peruaçu River, there are important sites, like Janelão Grotto (one of the biggest Brazilian caves) – a rock art site with expressions of São Francisco tradition and a small lithic artifact studio; Lapa do Boquete – with dates about 11,500 to 1000 BP, including six burials; and Abrigo do Malhador, where

Archaic and Formative burials from *Una* tradition were found dating from 6500 to 1500 BP, among other sites.

Area 3 – Arcos / Pains: contains more than 3000 known caverns. These sites are not systematic or long term habitations of hunter-gatherers, instead they alternately were utilized by two different ceramic groups, *Una* and *Aratu* (usually a group that did not utilize caverns), with dates from about 1840 to 450 BP (HENRIQUES, 2006). The deeper recesses of these caverns were used to deposit pottery (urns), probably for protection.

Area 4 – Unai: The caverns of this area – allied with plan topography, generous animal and vegetable resources and a lot of available chert for knapping – were perfect to shelter human groups during the Pleistocene-Holocene transition, and later used by *Una* ceramists. The dates for this first utilization are about 8000 to 3000 BP, and 2900 to 430 BP for the ceramist use (XAVIER, 2008).

5.2. Northeastern region

Presenting a great meta-sedimentary context, with erosional variability, this region presents excellent conditions to preserve rock art.

Area 5 – Central: located in a karst area, also within the Grupo Bambuí, in Lower São Francisco River. The site Toca da Esperança presents hunter-gatherer levels dated between 6500 and 2000 BP. In Pleistocenic levels, according to BELTRAO (2000), a pebble, a flake, and a chopper were recovered associated with a huge number of megafauna fossils. The dates, obtained by Ur/Th method – between 22,000 and 300,000 BP – are consistent with the context and the interpretation. Within the Central Project area, a lot of other sites were researched. Among them, the distinctive Brejões Grotto – one of the Brazil's biggest entrances, 160 m high – and the rock art sites around it.

Area 6 – Serra da Capivara: studied by Fundação do Homem Americano – FUMDHAM, has captured the attention of the international community, with a sequence of dates from 40,000 to 6000 BP (MARTIN, 1999: 99). Located in the Piauí-Maranhão sedimentary basin, are formed massive sandstones and pudding-stones – delineated by erosional agents over the course of thousands of years. The site Boqueirão da Pedra Furada, studied since 1978, presents lithic industries associated with hearths, establishing the biggest and most complete stratigraphic sequence obtained in Brazilian archaeological sites, spanning from 37,350 to 6150 BP, through all millennia with absolute dating. The site Toca do Meio revealed three contexts: ocher

pigments dating from 9000 BP; a polished axe blade dated in association with a hearth from 9200 ±60 BP; and ceramic fragments dated from 8960 BP. These data can modify the paradigm that, in Brazil, ceramic industries only began since 4000 BP.

Area 7 – Seridó: located in the most arid *Caatinga*, presents small shelters, with rock art surfaces repetitively exploited by groups, superposing their representations on older ones. We highlight the sites Abrigo do Mirador - where child burials date from 9410 BP - and Pedra do Alexandre – containing burials dated between 9400 and 2620 BP (MARTIN, 1999: 113–114).

Area 8 – Petrolina: was an archaeological salvage project at a dam site along the São Francisco River that resulted in the discovery of important sites, such as Gruta do Padre - which revealed the first diagnostic-guide-lithic material for a hunter-gatherer tradition, named *Itaparica*, which dates between 7580 and 2200 BP. Gruta do Padre is now submerged by Itaparica Dam.

5.3. Midwest region

This region presents sites located in different biomes.

Area 9 – Abrigo do Sol: cavern in sandstone, located in Amazon forest. The research of Miller distinguished 2 horizons: one Holocenic and one Pleistocenic. In the Holocenic horizon, we have hunter-gatherers and ceramists group occupations; their material culture is composed of lithic material (knapped and polished), some rare burials and engraved rock art. The dates of this horizon are between 7820 and 115 BP. The Pleistocenic horizon, associated to a fallen-blocks-level, presented dates between 14,700 and 12,300 BP.

Area 10 – Santa Elina: rock art site in quartzite, in the *Cerrado* biome. The works of VIALOU (1994) have shown occupations from the limit between Pleistocene/Holocene until the contact with the European colonizers. The dates from hunter-gatherers are between 10,120 to 2,350 BP, with material culture composed of rock art, of rock art artifacts, knapped lithic material, food traces and dozens of hearths. After this period, the site presents a ceramist groups occupation, dated from 275 BP.

Area 11 – Serranópolis: set of caverns simultaneously occupied. The main reference is the site GO-JA-01. It is a sandstone cavern, presenting dates from 10,580 to 8915 BP to *Itaparica* tradition, and limiting the hunter-gatherer occupations to 6,690 BP. Then an occupational hiatus

of the cavern until 1000 BP, oldest date of *Una* ceramist occupation in the place.

5.4. Northern region

The geomorphology of the Northern region, largely obscured by the Amazon forest, does not contain many caverns. Most of the archaeological sites in cavern environments quoted here are located in *ecotones*.

Area 12 – Monte Alegre: the Cavern of Pedra Pintada site has presented vegetable and fauna traces of groups adapted to live in a forest environment. Among the lithic artifacts, distinction to arrowhead pre-shapes, bifaces, unifacial scrapers, and raw-edged flakes. The dates of this site (^{14}C and Ur/Th) are between 16,190 and 9530 BP (ROOSEVELT et al., 1996).

Area 13 – Serra dos Carajás: transition area, lithologically rich in iron ore, exploited by miners during the 20th Century. Its cavern environments are rich in human vestiges. Recent studies (OLIVEIRA, 2006) point to the variability of the Amazon forest colonization by foragers groups. Among various interesting sites is Gavião Grotto, which occupies the ecotone Amazon forest/*Cerrado*. Among the finds are knapped stones, resin, seeds beads, food traces in hearths, and, in more recent levels, ceramic fragments, usually concentrated in the external and illuminated portion of the grotto. Dates extend from 8140 to 2900 BP (SILVEIRA, 1994).

6. Final Considerations

We have researched the close relationship between older human occupations and the cavern environments in Brazil. The caverns, mostly in karst environments, protect the archaeological evidence, especially the burials and the rock art. Sources of carbon for ^{14}C dating, like hearths, are well preserved in these environments, have provided good chrono-cultural sequences, as well as the oldest dates of the Brazilian finds. In conclusion, the caverns should receive our protection, whereas they provide important evidence of the first Brazilian residents and, maybe, some of the first residents of the Americas.

References

BELTRAO, M. (2000) *Ensaio de Arqueogeologia: uma abordagem transdisciplinar*. Zit Editora. RJ. Brasil. 168 pp.

COMIG and CPRM (2003) *Mapa geológico do Estado de Minas Gerais*. Belo Horizonte. Brasil.

COSTA, A. (1980) *Introdução à arqueologia brasileira*. Cia Editora Nacional. São Paulo. Brasil. 307 pp.

DIAS Jr, O. and E.T. CARVALHO (1983) A fase Itaipu, RJ. Novas considerações. *Arquivos do Museu de história natural da UFMG. Vol. 8/9*. Belo Horizonte. MG. Brasil.

EREMITES, J.; S.A. VIANA (1999/2000) O centro-oeste antes de Cabral. *Revista Usp. N44*. SP. Brasil. pp 142--189.

ETCHEVAMNE, C. (1999/2000) A ocupação humana do nordeste brasileiro antes da ocupação portuguesa. In: *Revista Usp. N. 44*. São Paulo. SP. Brasil. pp 112–143.

GUERRA, A., S. SCOFFHAM, A. SCORTEGAGNA, H. HASENACK (2007) *Atlas Geográfico Mundial – Versão essencial*. Fundamentos. São Paulo. SP. Brasil. 176 pp.

HENRIQUES, G. (2006) *Arqueologia regional da província cársica do Alto São Francisco: um estudo das tradições ceramistas Una e Sapucaí*. Dissertação de mestrado. Reprografado. São Paulo. SP. Brasil. 89 pp.

MARTIN, G. (1999) *Préhistória do nordeste do Brasil*. UFPE. Recife. Brasil. 395 pp.

OLIVEIRA, W. (2007) *Caçadores coletores na Amazônia: eles existem*. Dissertação de Mestrado. SP. 126 pp.

PROUS, A. (1992) *Arqueologia Brasileira*. Editora da Universidade de Brasília. Brasília, DF. Brasil. 605 pp.

ROUS, A. and M. SCHLOBACH (1997) Sepultamentos pré-históricos do Vale do Peruaçu – MG. *Revista do Museu de Arqueologia da USP. Vol. 07*. São Paulo. SP. 3–21.

RODET, J. (2002) In: *Géologie de la Préhistoire: Méthodes, techniques, applications*. CNRS, Paris. 2002.

ROOSEVELT, A.C., M. Lima da COSTA, C. Lopes MACHADO, M. MICHAB, N. MERCIER, H. VALLADAS, J. FEATHERS, W. BARNETT, M. Imazio da SILVEIRA, A. HENDERSON, J. SLIVA, B. CHERNOFF, D. S. REESE, J. A. HOLMAN, N. TOTH, K. SCHICK (1996) Paleoindian Cave Dwellers in the Amazon: the peopling of the

Americas. *Science*, 272(5260): 373–384.

SAMPAIO, D.R. (2001) *Revoluções nos paradigmas documentais na história e na arqueologia*. Monografia de conclusão de curso. UFMG. 37 pp.

SCHMITZ, P., A. ROSA, A. BITENCOURT, Orgs. (2004) *Pesquisas, Antropologia, N. 60. Arqueologia nos cerrados do Brasil Central. Serranópolis III*. Unisinos. São Leopoldo. RS. Brasil. 286 pp.

SILVEIRA, M. I. (1994) *Estudo sobre estratégias de subsistência de caçadores-coletores pré-históricos do sítio Gruta do Gavião, Carajás (Pará)*. Dissertação de mestrado. Usp. São Paulo. SP. Brasil. 151 pp.

VIALOU, A. (1994) *Pré-história do Mato Grosso*. Vol. 1. Santa Elina. Edusp. São Paulo. SP. Brasil. 226 pp.

WÜST, I. (1992) Contribuições arqueológicas, etnoarqueológicas e etnohistóricas para o estudo dos grupos tribais do Brasil Central: o caso Bororo. *Revista do Museu de Arqueologia e Etnologia*. N2. São Paulo. SP. Brasil.

XAVIER, L. (2008) *Arqueologia regional do noroeste mineiro: estudo de indústria lítica da bacia do rio Preto - Unaí, Minas Gerais, Brasil*. Dissertação de mestrado. SP. Brasil. 118 pp.

Symposium 2

EDUCATING CITIZENS ABOUT LIVING IN KARST

Arranged by:
Carol Zokaites
Jay Anderson

KARST EDUCATION IN WESTERN AUSTRALIA

JAY ANDERSON

WA Speleological Group (WASG)

PO Box 443, Cloverdale 6985, Perth, WA, Australia, rossjay@iinet.net.au

The conservation, management and protection of karst systems are an important issue that needs great consideration and attention. In Australia most of the karst land with caves is public land and the government has management responsibility. The state of Western Australia (WA) has a number of karst systems, with differing land tenure. As such, these areas also have a wide variety of karst management. The areas within Western Australia which are karstic include: the Nullarbor, the Kimberley Region, the Cape Range, and the south-west coastal calcarenites—including the Wanneroo cave belt near Perth (with the Yanchep National Park), and the Leeuwin-Naturaliste Ridge (and the Augusta Margaret River caves). There are two key areas that contain caves visited by the general public—Yanchep caves (1 hour north of Perth, the capital of WA) and the caves in the southwest (4 hours south of Perth). These sites are both in National Parks, however in the south, the tourist caves are managed separately by Tourism Associations.

Educating the community about karst is one component of Environmental Education that is often missed. There is no Government Department or Non Government agency that undertakes education about karst systems or living with karst. Yet, there are urban developments that contain karst close to the city. This paper will discuss a number of projects that have involved collaboration and partnerships – between land managers and speleologists. In particular, the key role of speleological volunteers and cavers in providing education about karst and caves to the local community. At a local level the speleological groups, like the grottos of the NSS, are involved in the majority of the conservation projects and management issues.

This presentation outlines a partnership project where interpretive signage was installed in a local National Park, funded by a grant obtained by a speleological group. An example of community events and adult education workshops are provided. Several karst workshops in the Perth area have been undertaken as a partnership between the Australian Speleological Federation (ASF) and the Greening Australia (GAWA). This has involved presentations on karst by speleologists and a field trip to see karst sites first-hand. Speleologists have also been involved in community events such as the annual Children's Groundwater Festival and National Science Week. This has included local displays, educative activities, presentations and the development of an informative sticker. The WA Speleological Groups have applied for funding to continue providing education about karst and in relation to "living with karst" for the WA local Community.

1. Introduction

There is a great need for the conservation, management and protection of karst systems. In Australia most of the karst land with caves is public land and managed by the Government. The state of Western Australia has a number of karst systems, with differing land tenure, and therefore, a wide variety of karst management. The karstic areas within Western Australia include: the Nullarbor: the Kimberley Region: the Cape Range: and the south-west coastal calcarenites, including the Wanneroo cave belt near Perth (with the Yanchep National Park): and the Leeuwin-Naturaliste Ridge (and the Augusta Margaret River caves).

In Western Australia, speleological groups have been able to play a key role in environmental education. This has taken a number of forms: from community education displays, targeted presentations, and seminars to workshops, events, and projects involving the provision of interpretive signage. This paper will outline key achievements in the last 10 years with a focus on speleological involvement in relation to educating the community about living with karst.

2. Community Education Displays

The two Perth based speleological groups have worked together to develop displays for use at local community events. This includes the Yanchep National Park "spring

fest,” the Neerabup Community Environment Festival and the Yanchep National Park Centenary. Since 2003, speleologists have had regular involvement in the annual “Children’s Groundwater Festival” which occurs north of Perth. These displays are interesting and fun, and outline the amazing values and features of caves. Such displays are simple, quick and easy to set up and develop. There are a number of resources available for such events.

The displays at the Children’s Groundwater Festival focussed traditionally on raising awareness of groundwater on the Swan Coastal Plain, near Perth, WA. Through a variety of displays, presentations and interactive activities, children learnt about groundwater and water movement. The local speleologists were involved in raising awareness of karst, in particular the groundwater in limestone. Interesting posters, photo’s and activities were of interest to the children and their teachers.

3. Targeted Presentations and Seminars

A number of community seminars were held during 2002 and 2003 (Anderson 2003). This involved speleologists undertaking community education and presenting informative presentations on several occasions. The first (May 2002) was titled “Cavers caring for Caves.” The second seminar (July 2003) was titled “cave ecosystems, habitats and subterranean fauna.” The third workshop was held in the Margaret River cave region (September 2003) and titled “subterranean biodiversity and threatened fauna – specific examples from WA.” This latter workshop was held to co-incide with Biodiversity Month and Threatened Species Day. Afterwards, a dinner was held with over 60 people in attendance. These presentations and seminars were informative and interesting and have assisted in educating the local community about the karst in their backyard.

Local speleological groups are regularly invited to present short slide shows and presentations to community and adventure groups. These are a great opportunity to raise awareness of caves/karst systems, and to gain additional members. The presentations and seminars have been positive and well received in Western Australia.

4. Partnerships & Workshops

Speleologists share similar values and ethics with other conservation and environmental groups – this can form the basis for excellent partnerships. During my time in the role as ASF Conservation Co-convenor for WA, I initiated communication with Greening Australia (WA). This led to the partnership between the ASF and GAWA. We were able to develop a one-day field trip aimed at school teachers,

environmental educators and community members. The first workshop was titled “Subterranean Safari, exploring the karst and cave systems of the Swan Coastal Plain” and occurred in 2004. The workshop was free and the minimal costs were covered by both groups. This workshop was so successful that it was organised again in 2006 and then again in 2007. Each workshop involved between 20 to 25 people who participated in the day - involving presentations on karst, site visits (Fig 1) and discussions.



Figure 1: Local Speleologist discussing limestone during the ASF/GAWA Workshop 2007

5. Projects & Interpretation - Sharing Australia’s Stories at Yanchep

During July 2005, Western Australian Speleological Group (WASG) was announced as one of the successful applicants for a “Sharing Australia’s Stories” Grant from the Commonwealth Government (Department of Environment and Heritage). The Sharing Australia’s Stories Program supports activities and projects that help tell the story of the nation. The Program objectives were to give individuals and communities the opportunity to identify and communicate their local contribution to the nationally significant natural, indigenous and historic heritage of the Australian nation.

The new thematic and informative interpretative signage at Yanchep National Park was officially opened December 17, 2006. The Hon Dianne Guise MLA (local member for Wanneroo) opened the day and unveiled the signs. Phil Smeeton (Parks & Visitor Services Coordinator -Swan Coastal District) from the Department of Environment and Conservation was pleased to see the interpretation signs along the walk trail. The signs are part of the self-guided Boomerang Gorge (Dwertwa Mia) Trail. Boomerang Gorge is a collapsed cave system and forms part of a larger karst system at Yanchep. The karst systems at Yanchep National Park are a unique example of natural processes.

Yanchep National Park has at least 500 caves and karst features within the park. The areas karst system is of local and national significance. This is a spectacular area of the Yanchep National Park, consisting of Tuarts and other native vegetation in an area close to the well known “Crystal Cave.”

The signage was a key project that was achieved by a partnership between several community volunteer groups and the key Government Agency; The WA local Speleological Groups (WASG & SRGWA- Speleological Research Group Western Australia) in consultation with DEC staff (Yanchep National Park, and the department’s Sign Design Studio & Interpretation Section.). This project aimed to increase public awareness of a unique karst system that exists here in Western Australia (WA). This project tells the story of natural processes shaping Aeolian limestone karst systems, and their associated cave fauna at Yanchep, Western Australia. This project is part of the speleological group’s broader goal to raise the profile of karst systems and to educate the community about karst systems in WA.

The project communicated on a local and national scale the importance of this karst and cave system and the unique natural processes that have made this area of national significance possible (Fig 3). The written material was developed through creative networking workshops involving speleologists and interpretation specialists. There were two workshops held to develop the draft interpretation signage (September 18, 2005 and October 23, 2005). Figure 4 shows some the enthusiastic speleologists and volunteers that were involved in the development of the signage. These workshops primarily involved local speleologists and community volunteers. The written material was then put in an electronic format and edited by several of the project team. The interpretation material was then finalised in close consultation with several specialised DEC interpretation staff. The signage outlines the unique geology of the area and how the karst system formed—the region’s unique Tamala limestone and the existence of specialised subterranean fauna in the local caves—these are some of the Stories that are shared at Yanchep. This is an excellent example of speleological involvement in karst education.

6. Events - National Science Week

There are a range of events that speleologists could become involved in – from World Environment Day to Threatened Species Day to Biodiversity Month. One speleological group (Cavers Leeuwin -based in the Margaret River region) co-ordinated a local activity during National Science week in August 2008. Local cavers, speleologists, and community



Figure 2: National Science Week, karst demonstratio:

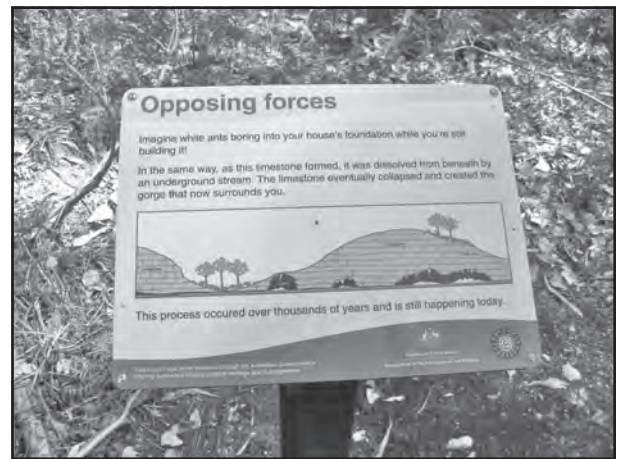

Figure 3: Interpretive signage at Yanchep

members collaborated to organise a local event for National Science Week. A \$1,000 grant from the National Science Week WA co-ordinating committee assisted with resources for the event. This included promotional posters, activity resources and publishing an educational sticker.

As part of the National Science Week event, a “caves day” was held at Calgardup and Giants Cave on Saturday the 23 August. This involved a partnership of the Department of Environment and Conservation (DEC), The Cape to Cape Catchment Group (CCG) and Cavers Leeuwin. Local cavers and speleologists set up a display on the “science of speleology” with some hands-on activities and examples of fossils, rocks and cave fauna. Visitors to the two National Park caves, were able to participate in a cave experience, assisted by local cavers, members of Cavers Leeuwin. Visitors to Calgardup Cave were also able to participate in a surface walk, guided by a CCG volunteer – exploring the flora of the karst system, and looking at surface karst features. Visitors to Giants cave were privileged to participate in an interactive discussion on karst hydrology

and geology and to view the karst model in action (Fig. 2). All visitors were able to take home an informative sticker (Fig. 5) that shows some aspects of the karst system. Later that night, community members attended a community presentation. This was a small event that was successfully organised by local speleologists.



Figure 4: Some of the speleologists involved in the Yanchep Project.



Figure 5: The Sticker developed by local Speleological Group, Cavers Leeuwin, in 2008 for National Science Week.

As a result of this event, Cavers Leeuwin members submitted a further application to the Federal Government for a \$5000 grant. Recently, we have been advised that this was successful. The plan for National Science week 2009 will include extensive regional promotion, publication of educational information and several community presentations on various aspects of the “science of speleology”. The Grant was titled “Discovering Caves and Speleology: The Science of the Subterranean”. This is an excellent opportunity to be involved in community education and in educating local residents about living on

karst. The overall purpose is to increase the awareness and understanding of visitors in the science of speleology. Local speleologists will work in partnership with several local organisations. The project will be a collaboration between the Department for Environment and Conservation, Cavers Leeuwin and the Cape to Cape Catchment group. However, other organisations are involved, such as the Augusta Margaret River Shire, the WA Museum and ANSTO (Australian Nuclear Science and Technology Organisation) will also contribute to the organisation of the project, to varying degrees. This is another example of proactive work by local volunteers and shows the importance of speleological volunteers in land management.

7. Summary

This paper has outlined a number of different community education techniques that are used by local speleologists. This includes a partnership project where interpretive signage was installed in a local National Park, funded by a grant obtained by a speleological group. The community karst workshops were a very simple yet successful concept. Speleologists continue to be involved in community events, local displays, educative activities and presentations. We hope to be able to develop a booklet similar to the “Living on Karst” and “Living With karst” publications. It is pleasing to see karst education in action in our community.

Acknowledgements

Special thanks to my husband Ross, for his support and understanding when I’m off organising another event or staying up late at night to apply for another grant. My great appreciation goes to other members of the WA Speleological community who have been involved in local events, notably Rob Susac.

Our appreciation and thanks go to members of the NSS Conservancy’s who at the 2006 Cave Conservancies Forum, gifted to us, the amazing “karst hydrological model”. We have used this at a number of local community events over the last two years. Thanks again.

References

- Anderson, J 2003. Environmental Education, Collaboration and Partnerships—What’s that got to do with You?” Article printed in the Australasian Cave and Karst Management Association (ACKMA) Journal.

CAVE ENVIRONMENTAL EDUCATION: THE GREEK EXAMPLE

KONSTANTINA ARETAKI

*Mphil Prehistoric Archaeology, Secretary of the Department of West Crete of Hellenic Speleological Society, High School Teacher,
Member of the Pedagogic Team of the Environmental Education Center of Vamos (Chania, Crete)
Michael Maraki 9, GR74100 Rethymno Crete, GREECE, aretaki@students.phl.uoc.gr*

This paper deals with the treatment of caves in Environmental Education Programs conducted in primary and secondary schools in Greece. The need for environmental education emerged in most of the Western European countries and the USA during the sixties, in the face of increased environmental problems due to the ecological crisis. Many congresses and international meetings through the sixties and seventies followed, but it was not until 1977, at the International meeting organized by UNESCO in Tbilisi (Republic of Georgia), that the goals, targets, and directives of environmental education were consolidated. In Greece, environmental education became a concern of the state after 1977, and in 1987-1988 the Ministry of Education organized the program for the schools. Since then, the environmental educational program has been presented on an optional basis in the schools

In the 1992–1993 school year, the topic of caves was first introduced into the program at a high school in Rethymno (Crete) with the help of the local speleological club. There has been an increasing interest in caves in this program, especially in areas located close to show caves or other major underground cavities. During the 2005–2006 school year, five such programs were conducted in the schools on the island of Crete alone. This year, one of the 62 environmental education centres in Greece plans to establish a National Thematic Network about caves and this should bring into contact the schools, teachers, and students from all over Greece who are working with caves.

The aim of this paper is to present the status of caves in the environmental education program in Greece, both past and present, and examine how speleologists and speleological clubs can contribute, helping teachers and students in the realization of such programs.

1. History of the Environmental Education

Dr. William Stapp, University of Michigan, was the first to concisely define Environmental Education (EE) in 1969: “Environmental education is aimed at producing a citizenry that is knowledgeable concerning the biophysical environment and its associated problems, aware of how to help solve these problems, and motivated to work toward their solution” (Stapp, 1969). In his 1970 Environmental Message to Congress, the United State’s President Richard Nixon emphasized the importance of environmental literacy. “It is also vital that our entire society develop a new understanding and a new awareness of man’s relation to his environment - what might be called “environmental literacy”. This will require the development and teaching of environmental concepts at every point in the educational process” (Nixon, 1970).

As EE was still an emerging concept at this time, these definitions were not seen as definitive. At an international level, EE gained prominence during the 1972 Stockholm Conference on the Environment. Recommendation 96 of

this conference recommended environmental education as a critical means to address the world’s environmental crises. This recommendation was addressed at the 1975 International Environmental Workshop in Belgrade, Yugoslavia, which resulted in the Belgrade Charter (Barry, 1976), a document which begins to define the goals and objectives of EE. The Belgrade Charter was further refined at the Intergovernmental Conference on EE in Tbilisi, Republic of Georgia in 1977: “Environmental Education, properly understood, should constitute a comprehensive lifelong education, one responsive to changes in a rapidly changing world. It should prepare the individual for life through an understanding of the major problems of the contemporary world, and the provision of skills and attributes needed to play a productive role towards improving life and protecting the environment with due regard given to ethical values” (UNESCO, 1977).

2. What is Environmental Education?

Environmental Education (EE) is a process in which individuals gain awareness of their environment and acquire

knowledge, skills, values, experiences, and also the **determination**, which will enable them to act - individually and collectively—to solve present and future environmental problems (UNESCO Web site). EE is a complex process, covering not just events, but a strong underlying approach to society building as a whole. EE is a learning process that increases people's knowledge and awareness about the environment and associated challenges, develops the necessary skills and expertise to address the challenges, and fosters attitudes, motivations, and commitments to make informed decisions and take responsible action (UNESCO, 1977).

Analytically, the components of EE as they were stated in the Tbilisi declaration are (UNESCO, 1977): (1) Awareness and sensitivity to the environment and environmental challenges, (2) Knowledge and understanding of the environment and environmental challenges, (3) Attitudes of concern for the environment and motivation to improve or maintain environmental quality, (4) Skills to identify and help resolve environmental challenges and 5) Participation in activities that lead to the resolution of environmental challenges.

EE is aimed at producing a citizenry that is knowledgeable concerning the biophysical environment and its associated problems, aware of how to help solve these problems, and motivated to work toward their solution (Stapp et al., 1969).

3. Environmental Education in classroom: An Interdisciplinary Approach

Environmental Education (EE) is taught in traditional classrooms, in communities, and in settings like nature centers, museums, parks, and zoos etc. Learning about the environment involves many subjects -earth science, biology, chemistry, social studies, even math, language and arts- because understanding how the environment works, and keeping it healthy, involves knowledge and skills from many disciplines. (Environmental Education and Training Partnership Web site) It consists in an interdisciplinary approach to EE, whereby EE embraces all disciplines, and covers all levels and types of education including **life-long learning**.

Understanding EE is a keystone component in order to achieve the ultimate goal of conservation of biodiversity. Therefore, it is important to distinguish between EE and science. EE, as defined by Arai and Sprules, is the education that concentrates on the relationship between humans and their environment (Arai et al., 2001). On the other hand, science can be considered as an effective tool and

one approach of knowing the environment. Lack of science will no doubt negatively affect better understandings of the environment. For instance, Cobb (1998) states that, environmental science needs to be integrated with social science (e.g., biology, chemistry, and geology with economics and politics) in order to create new ideas of how environment works as well as how things interact with one another. Environmental issues and science education are very complex to be addressed in a single course. Thus, efforts must take place in early age and continue through all levels of education (Aljabber, 2002).

For this reason, it is essential to foster links between EE in the formal curriculum and projects in non-formal education. Projects such as the establishment of environmental clubs in schools, greening of school-yards, environmental awards, journalistic activities and others, are essential to sensitize young people to their immediate environmental as well as many other complex issues related to sustainable development. Having such a complexity, the need to include environmental education in some curriculum, if not all, is very important. Arai and Sprules (2001) say, "Environmental Education should be interdisciplinary and actually included across the entire curriculum and in all subjects." Students, through EE, will be able to develop appropriate solutions to important environmental issues, think in critical ways, take suitable actions, and participate effectively in both local and global environmental problems. Learning EE will provide students with the opportunity to exchange various opinions and ideas about the main concepts and skills that are very important in the society. Moreover, EE enables students to understand details and connections that they discover rather than memorizing of solid facts and concepts in classrooms (Environmental Education Training Partnership, 1999).

4. What about Environmental Education in Greece?

In Greece, Environmental Education (EE) became a concern of the state after 1977. In 1987-1988 the Ministry of Education had started to organize Environmental Education Programs for the schools. Since then, the EE programs have been presented on an optional basis in the schools. But it is important to mention here that the State proceeded in 1990 to establish Environmental Education Centres (EEC) by decree (1892/1990, FEK 101 / v.A/31-7-90, article 111 par. 13, Establishing Centres for Environmental Education) operating subsidiary in the EE programs conducted in schools. The Environmental Education Centres (EEC) are designed to create cognitive and meritocratic setting for students, to develop responsible attitudes and participatory

behaviors that contribute to the protection of the ecological balance and of the quality of life and promote sustainable development. Subject of the Pedagogy Working Group on every EEC is students' training, teachers' further education, the production of educational material, the development of thematic networks, regional and international cooperation, and research on environmental issues and on Environmental Education. Currently, there are 62 operating EEC throughout Greece that are financed by the European Union (65%) and by National Funds (35%).

5. Environmental Education and Caves

Speleology can be practiced in many different ways: as an extreme sport, an academic enterprise, or, as it is often the case, a combination of both. Whatever its emphasis, speleology entails meaningful encounters of its practitioners with the karst environment. One might ask how caves and EE can be related. But caves are a field rich in environmental issues. Apart from the fact that the caves are monuments of natural and cultural heritage that deserve protection, they are also a mostly closed and fragile ecosystem, highly sensitive to any human intervention or other external interference. Furthermore, it is necessary to introduce the caves in the sight of sustainable development, because the examples of incorrect touristic development of caves from non-experts are common.

Caverns and caves offer the possibility of numerous speleological activities of educational, scientific, entertaining and athletic content. An interdisciplinary approach of caves contributes to the related study of the environment and their findings from the perspective of Physical Sciences, Anthropology, History, Economics, Culture, Arts, Medicine, and Sports. EE can be applied in the environment of caves since, by definition, it constitutes an environmental process, of a permanent nature, that advances the knowledge of the interaction of human kind with its biophysical, cultural and social environment (Panagiaris et al., 1993–1994). Thus, the interdisciplinary approach is essential for the approach of cave ecosystem.

Caves are suitable for EE when the relevant activities comply with the perspectives of EE, namely the awareness and the engagement of individuals and social groups with environmental issues, the acquisition of experience, the development of expertise for the definition and resolution of environmental problems, the conscientious recognition of individual tasks and responsibilities for the preservation of the environment, and the formation of values and concerns for an active participation in an attempt to improve its protection (Panagiaris et al., 1993–1994). Furthermore,

the objectives of EE about caves could not be very different from the objectives set for the EE in general, tailored to the specific nature of the existence and of the management of those closed underground ecosystems. Compendiously, we refer to the contact with the underground world through active learning, the discovery of diachronic human relationship with the caves, the acquaintance with the fauna and flora, their specificities and their precarious existence, the approach of the natural processes of their creation, and their ecological importance (Stratidakis, 2006). EE and caves also included the creation of environmental awareness to achieve the sustainable management and sustainability of the cave environment.

An EE Program is realized not only to inform and sensitize students to issues concerning the environment, but also to generate actions and projects, if there is of course such a possibility, which will contribute in one way or another in the general information of local and not only society, in the saving and protection of an endangered ecosystem, in the preservation of others from destruction and from human interference, etc. For this reason, each EE Program must be followed by a series of actions and interventions aimed at changing attitudes and behaviors, through the acquisition of knowledge, not only by the students themselves, but also by the wider community, to raise awareness and involvement for the protection and proper use of tourist caves in the context of alternative forms of tourism.

6. Aims and Goals (analytically):

One of the major aims of EE in caves should be the awareness, the activation, and the acquisition by students and teachers of critical thinking in environmental protection and protection of caves in particular, thus contributing to sustainable and viable development. The goals of a cave Environmental Education program should be:

- To introduce students to the unknown “world”, the cave, and to what it encompasses (traces of past human presence, troglodite organizations and bats, stalagmites and stalactites and other speleothems, mythology, history, lores and legends). Particular purposes in that direction are:
- Recognizing the historical value of the caves, as many of them are associated with historical events of our recent past (mostly hideaways during wars).
- The collection of traditions and stories about the caves and the realization that the cave was always a source of inspiration for the creation of folk

traditions and myths.

- The perception that the ways in which humans have used caves in ancient times do not differ much from the ways in which they have been using them until recently. This means that the caves are “magazines” for archaeological remains. The human presence is strong in them throughout our development and progress.
- To understand that a cave is a mostly closed ecosystem that is at risk from any kind of human intervention.
- To be aware of and appreciate the value of the semi-closed ecosystem of the cave and the need for conservation and protection. To study the ways and consequences of human intervention in the caves. To recognize the threats. Through these means, seeking the alteration of the traditional perceptions about caves and adopting a culture of protection.
- To visit and work in caves, so they could overcome the fear that often results from ignorance and all the fiction associated with them.
- To become active citizens who will contribute to the sustainability of the cave.
- To learn the ways of touristic development of a cave, partially by creating paths or totally in the prism of alternative tourism or ecotourism.

The specific objectives of a Cave and Environmental Education program should be:

- The active and conscious participation of students in managing the physical, social, and cultural environment towards sustainable development.
- The indirect impact on the wider social environment (family, friends, neighborhood), since the students act as “core” of awareness.

7. The example of Greece

Greece is a small country (131,990 km²) but plentiful in underground caves and cavities due to the existence of calcareous rock formations that favor the development of karstic caves. It is considered the first country universally in cave concentration (Petrocheilou, 1985). The caves

in Greece are estimated to number around 10,500 (Adamopoulos, 2005). But, the majority of Greek citizens are unaware of the richness of the Greek underground world. Intercourse with the subterranean cave ecosystems is not always accessible to everyone, but only to cave specialists, who have proper training. Consequently most of the people are not familiar with the existence and the beauty of the underground “wealth” of Greece.

We all know that caves are dark and enclosed spaces and most of the people associate them with the danger, fear, and awe they cause. But the caves are more. These are closed and very sensitive ecosystems, with their own distinct and often unique flora and fauna. For their development, millions of years were needed and for the creation of their decoration, hundreds of thousands of years. Most caves in Greece are karstic, forming in calcareous rocks thanks to the solubility of that rock. And because Greece is a predominantly karstic country with 65% of its area covered by limestone, numerous caves and cavities, underground rivers, and gulches are formed during the Quaternary and Tertiary in massive Upper Cretaceous limestone, in younger argillaceous limestone, or in younger conglomerates (Petrocheilou, 1985). The survey and study of caves involve several branches of natural sciences such as geology, hydrology, mineralogy, paleontology, biology, zoology, physical anthropology, etc., and of human sciences such as archaeology, history, folklore, history of art, etc. (Panagiaris et al., 1993–1994). The caves were also one of the first homes of mankind. The traces that have left are a kind of palimpsest for archaeologists. Because human use in most of them as places of residence, burial, worship, etc., was continued for thousands of years and have not ceased to be used in different ways even today, in the era of internet and the high technology (Aretaki, 2004). The multi-faceted approach of the caves helps in setting up interdisciplinary working groups to better support the work of teachers on the education of pupils in the environment of the cave.

The caves have been investigated by Environmental Education community in Greece in an early stage. Initially, it was a relatively unknown field of EE, which is gradually gaining ground. Several schools in various parts of Greece have dealt with the issue of caves within the School Environmental Education Program. In 1992-1993, the topic of caves was first introduced into the program at a high school in Rethymno (Crete) with the help of the local speleological club (Department of West Crete of the Hellenic Speleological Society). There has been observed an increasing interest in caves, especially in areas located close to show caves or other major underground cavities. During

2005-2006, five such programs were conducted in the schools on the island of Crete alone.

Speleological Clubs contribute utmost to the promotion of the EE in caves. In 2005, the Department of Environmental Education in Secondary Education of the Rethymno Prefecture in cooperation with the local Department of West Crete of the Hellenic Speleological Society organized a workshop in 2005 attended by over 100 teachers under the title: "Caves: fascinating monuments of nature" (Aretaki, 2006). Speleological clubs organize EE programs or contribute with their knowledge and their technical support to the organization of such programs in schools. Speleological Club of Crete (SPOK) has produced two "cave cases" (a complete information material and practical instructions) which have been designed to offer a successful learning experience which involves an interaction of the learner, the materials, the teacher and the context, same as the Natural History Museum of Crete concerning the underground paths of water.

Archaeological museums have included in their educational programs activities related to the caves. For example, the Archaeological Museum of Rethymno operates a program under the title: "One day with the inhabitants of Gerani Neolithic cave". This year, two Environmental Education Centres have organized projects for schools in a permanent base (Pramanta EEC- North Greece, "Anemotrypa Cave: Underground Paths" and Vamos EEC-Crete "The Mystic World of Caves").

From all the above it is obvious the huge interest in the caves so much of speleological clubs, as those involved in EE. With that ascertainment, the Environmental Education Centre of Vamos in Chania Crete has decided to proceed to the foundation of a National Thematic Network about caves, which should bring into contact the schools, teachers, and students from all over Greece who are working with caves, so that they could have access to the tools, supplies and all the information and material that is needed for the realization of their school projects concerning the caves (Aretaki, 2008).

8. Conclusion

Responsible and informed action has been a goal of environmental education since the first definitions of this field emerged nearly thirty years ago. More recent definitions continue to emphasize the central role of responsible action (Wilke, undated). There is a proper place for citizen action in the environmental education curriculum. The sequence of instruction should end with

citizen action and it should be an option, not a requirement.

Environmental literacy goes beyond possessing knowledge and skills, since even well honed skills for taking action cannot have an effect unless they are used. During the years of their formal education, learners develop the inclination to put their knowledge and skills to work, acting on their own conclusions about what should be done to ensure environmental quality (North American Association for Environmental Education NAAEE Web site).

Environmental education aims to foster in learners a sense of their own efficacy--a confidence that they have the ability to inquire, learn, analyze, decide, communicate, and participate. Through the learning process, students become independent and responsible thinkers and actors. Students learn that they control their own success or failure, and they grow in the knowledge that their actions can make a difference.

Environmentally literate persons possess a strong sense of citizenship. They understand the role of citizens in a democracy, and accept their part with responsibility and commitment. During their school years, learners grow into the role of citizen, developing the personal and civic insight and traits that motivate action. Cultivating their own environmental and social ethic helps learners make difficult decisions and accept personal responsibility for those choices (Wilke, undated).

In conclusion, the preoccupation with the caves is not an easy task. But it should not be a subject only for the specialists and trained. Everyone should have the opportunity to know the cave environment. The connection between Environmental Education and caves will contribute greatly to a better understanding of this unknown and mysterious world that lies so close to us, but so far from us in the same time.

References

- Adamopoulos K. (2005), The deepest and the longest caves in Greece. *Proceedings of the 14th International Congress of Speleology*, Vol. 1, 219-229.
- Aljabber Jabber M. (2002). The Role of Environmental Education in Conservation Biology, March 7, 2002, Indiana University, Bloomington, SPEA.
- Arai, E. and Sprules, S. (2001). The status of environmental education in British Columbia public schools: Grades 6, 7, and 8 in the Vancouver school district as a case study. University of British Columbia.

- Aretaki, K. (2006). Caves and Environmental Education. The program of Vryses High School: "The Kryonerida cave at Vafe and other caves of the Apokoronas area." *2nd Congress of Environmental Education School Programs*, Vol. B', 846–853.
- Aretaki, K. (2008). A Proposal of the Constitution Of a National Thematic Network for Caves, 4th *Congress of the Panhellenic Union of Educators in Environmental Education* (Web site: www.kpe.gr).
- Barry, J. (ed.). (1976). The Belgrade Charter: A Global Framework for Environmental Education. *Connect: UNESCO-UNEP Environmental Education Newsletter*, 1 (1), pp1–3.
- Cobb, T. B. (1998). On the miscibility of science and environmental education. *Journal of Environmental Education*. Vol. 29. Issue 4. pp 5–9.
- Environmental Education Training Partnership (1999). Environmental education in a standards-based curriculum. Vol. 21. <http://www.comdev.ag.ohio-state.edu/eetap/pdf/info51.pdf>.
- Decree 1892/1990 (FEK 101 /τ.Α/31-7-90) article 111 par. 13 περί ίδρυσης Κέντρων Περιβαλλοντικής Εκπαίδευσης .
- Decree Γ2/1242/8-3-93 ΥΑ, (FEK 175/Β/19-3-93), Ίδρυση και Λειτουργία Κέντρων Περιβαλλοντικής Εκπαίδευσης. Ανάγκη πραγματοποίησης Ειδικών Προγραμμάτων για την ανάπτυξη της ΠΕ
- John, F. (1995). Teaching for a Sustainable World: the Environmental and Development Education Project for Teacher Education, *Environmental Education Research*, Volume 1, Issue 1, 21–33
- Kamilaki, E. (2005). A subterranean world. *Proceedings of the 14th International Congress of Speleology*. Vol. 1, 337–338.
- NAAEE. (1997). Environmental Education Guidelines for Excellence: What School Age Children Should Know and Be Able to Do. Troy, OH, Draft, April.
- National Environmental Education Advisory Council. (1996). Report Assessing Environmental Education in the United States and the Implementation of the National Environmental Education Act of 1990. Washington, DC: U.S. Environmental Protection Agency, Environmental Education Division, December.
- National Research Council. (1996). National Science Education Standards. Washington, DC: National Academy Press.
- Nixon, R.M. (1970). President's Message to the Congress of the United States. In *Environmental Quality, the First Annual Report of the Council on Environmental Quality*, together with the President's Message to Congress. Washington, D.C.: U.S. Government Printing Office, S/N 0-389-110. ED 062-109, p.11.
- Panagiaris, G & Pantazidou, A. (1993-1994). Caves and Environmental Education. *5th International Congress of Hellenic Speleological Society "Cave Development, Evolution and Environment"*. *Bulletin of the Hellenic Speleological Society XXI*, 224–231.
- Petrocheilou, A. (1984). *The Greek caves*, Athens.
- Petrocheilou, A. (1985). The main Greek caves and their exploration. *Archaeologia* 15, 83–86.
- Stapp, W.B., et al. (1969). The Concept of Environmental Education. *Journal of Environmental Education*, 1(1), 30–31.
- Stratidakis, C. (2006). The environmental education at the Cretan caves. *Proceedings of the 2nd Cretan Speleological Symposium in memoriam of Eleftherios Platakis*. pp. 63–66.
- UNESCO (1977). Intergovernmental Conference on Environmental Education Organised by Unesco in co-operation with UNEP, Tbilisi (USSR) 14- 26 October 1977, Final Report, Paris, April 1978.
- Wilke R., undated, Should Action Be A Goal? Yes: PERC: Property and environmental Research Centre Web site: <http://www.perc.org/articles/article736.php>

SCHOOL DIDACTICS ON CAVES AND CAVING IN ITALY

GIOVANNI BADINO^{1,2}, DANIELE BERARDI¹, SIMONA BONARDI¹, GIAMPIERO MARCHESI¹, MARCO OTTALEVI¹, CHIARA SILVESTRO^{1,2}

¹*Società Speleologica Italiana*

²*Associazione Gruppi Speleologici Piemontesi*

In the past few years, the lack of a younger generations in the life of speleological groups and their activities has led the “old” cavers to develop new ideas and events in order to involve younger people. One of these initiatives was the “Speleo a Scuola” Project of the Association of Caving Clubs of Piemonte (AGSP); this involved 300 schools and 18,500 students up to now. More recently the Italian Speleological Society (SSI) drew up a questionnaire entitled “Communicate Caves” about Speleological Didactics, and this has been the starting point for the analysis of the national situation presented here. At present the SSI coordinates the Italian Speleological Didactics program on the basis of the experiences of Italy and the rest of the world, but we think it would be very useful to coordinate this work at the international level.

1. Introduction

In the past few years, the lack of a younger generation in the life of speleological groups and their activities has led the “old” cavers to develop new ideas and organize new events in order to involve younger people: dialogue with the schools is, of course, one of the main channels of communication available. One of these initiatives was the “Speleo a Scuola” (*Caving at school*) Project implemented by the Association of Caving Clubs of Piemonte (AGSP), thanks especially to the support offered by the Piemonte region. This project, born in 2003, has until now involved 300 schools and 18,500 11- to 18-year-old students, who are of an age that could soon provide the new blood needed in the speleological world. The SSI Association (“Society Speleological Italian”) developed a questionnaire “Communicate Caves” about Speleological Didactics, and this has been the starting point for the analysis of the national situation.

2. Results

Until now, 38 questionnaires have been returned; the Piemonte region was the first to take an active part in caving didactics, followed by Puglia, Lombardia, Friuli-Venezia Giulia and Toscana. Several groups had already been involved in caving didactics for 25 to 30 years, but, in the last five years, the number of clubs interested in the topic has grown significantly. The most popular locations for working with this are natural caves, with most projects conducting a variety of activities in show caves, although a few do so in artificial caves. The caves tours organized are often preceded by theoretical presentations, largely Power Point Presentations and videos, and by hikes aimed at discovering the phenomena of surface karst. Some cavers, however, still use slides.

In the past three years, according to the available data, more than 5000 have participated, and the number is constantly growing. The activities are generally undertaken in the province or region, rather than on the level of the commune, and are carried out by speleologists who belong to a single group rather than comprising the simultaneous efforts of several groups or of non-members. Some 60 Environmental Educational Centers include speleological activities in their programs. Furthermore, environmental and hiking guides, speleological guides and other tour operators often participate, even if they do not belong to speleological groups, because they work in a similar field. In addition to caves tours, other activities are organized such as events, conferences, public video projections, exhibitions and conventions.

Many educational materials, including books and brochures, have been published, with schools the most common beneficiaries of these programs. In the last three years, from 2005 to 2007, we had the following participation:

- 700 Nursery children
- 28,000 Primary School children
- 15,600 Junior High School students (from 10 to 13 years old)
- 9,000 Junior High School students (from 14 to 18 years old)

It is also interesting to note that 17,200 people outside the educational field took part in caving events. We have contacted some 70,500 people in these three years. The

speleological and didactic activities conducted so far have been successful and heightened the interest of the participants.

3. The Piedmont Case

A short description of the first of these programs, the AGSP didactic project Speleo a Scuola (SaS) that took place in Piedmont Region should be of interest. This region is located in the NW part of Italy. Its territory has a surface of 25,000 km², with 43% being mountainous and including various relevant karst areas. The two main aims of this project were as follows:

1. to introduce teenagers to the underground world and its characteristics, charm, and fragility, as well as the need for protection; the importance of both exploration and the dedicated scientific investigations were included, and the recognition of regional karst resources and territories were highlighted.
2. to encourage 11- to 18-year-olds to participate in caving and possibly join one of the many regional caving clubs and participate in their activities. This is the age when new sporting hobbies are initiated, and if caving appeals to them, they can join a caving club as early as 15, which is considerably lower than the average age of beginning cavers at present.

The project has attained positive results in the past few years, as can be seen in Table 1.

Requests for participation were sent to a selection of the secondary schools in the region, especially those located in the areas of actuation of speleological groups or areas with karstic zones. In these provinces there are about 245500 students of this age range, which means that in 5 years the AGSP was able to contact 7.5% of the pupils from 11 to 18 years of age.

School years	Schools involved	Students involved
2003/2004	51	3040
2004/2005	69	3648
2005/2006	72	4975
2006/2007	63	3944
2007/2008	44	2854
Total	299	18461

Table 1: Participation of schools and students from 2003 to 2008.

Such a positive outcome was not expected, but it is due to the availability of cavers and their ability to communicate their own enthusiasm for speleological activity, as well as the positive interaction made possible by the schools. Some 75 cavers have been involved in the project every year.

4. Discussion

The success of the Piedmont experience is surely due mainly to the following factors:

- the project was offered to the schools as a joint effort of the AGSP and the Piedmont Region Environmental Directorate;
- AGSP was able to establish a reliable partnership with both the schools and the Piedmont Region, which funds the project;
- caves and speleology are interesting issues which are related to many educational topics, from humanities to science.

The project is flexible enough to be perfectly integrated into the school program and its classes. It is based on three separate moments:

- the class lesson, where the topics are selected on the basis of the regular class, with the lesson focused on an appropriate theme, either scientific, anthropological or social;
- the training, usually done on a climbing wall, which simulate typical underground activities, such as crawling, through narrow horizontal passages of the tackling of vertical drops using ropes.
- Visits to a real cave, natural and undeveloped, although restricted to a horizontal and easily traversed one; this is usually the most significant moment in the program.

The project offers interaction with classes such as science, geography, Italian language, physical education, agriculture and also religion.

The investment in the project has been 35000 €/year, used to pay for the caving activities, the secretariat, technical equipment (helmets) and the printing of a booklet (The world of caves) especially written for this Project. The activity is completely free for the schools.

The Project involves widespread cultural action, and results are expected in the long run. In the short run, a few new members are expected to join speleological groups in areas where awareness is greater and sports options are limited. The Project was terminated during the scholastic year of 2008/2009 due to a lack of public support and too few cavers interested in the activity, but the AGSP is looking for new economic support and the development of a new Project which would be more involving for speleologists.

The history of the Piedmont project is typical. Interested groups, as general rule, contact Public Authorities, Foundations and Associations to request funds and other support. They usually get some support, although actual funds are rarely provided. Another area of consideration is the fact that speleological activities are seldom included in vacation packages.

4. Conclusions

This discussion has provided a quick look at the present situation. It is now time for a systematic *international* project to gather data in an attempt to involve more organizations. An exchange of ideas about the materials and other didactic should also be useful. At present, the SSI is coordinating the issue of speleological didactics on the national level in Italy, but we think it would be very useful to coordinate them on an international level.

GUATEMALA SHOW CAVES PARTICIPATIVE DIAGNOSTIC

FERDINANDO DIDONNA^{1,4}, LUCRECIA GORDILLO², NANCY MOLLINEDO^{1,3}, ANDRES ULLOA^{1,4,5}

¹Project ICEKE Instituto Centroamericano de Estudios Kársticos y Espeleológicos PO Box: 4729-1000 San José, Costa Rica

²INGUAT Instituto Guatemalteco de Turismo, Guatemala.

³ASOKARST Asociación para el Manejo Sostenible de los Recursos kársticos y Espeleológicos, Cobán, Guatemala.

⁴Grupo Espeleológico Antros

⁵Escuela Centroamericana de Geología, Universidad de Costa Rica, Costa Rica

The aim of this paper is to present the guidelines of the methodology and tools for a diagnostic study conducted in Guatemala. The country presents karst in an important area (~15,000 km²), and the most extensive karst is in the northeastern department of Petén. It is estimated that there are about 150 caves that serve as ceremonial centers. The Guatemala show cave situation is the most dynamic in all Central America with at least 16 sites open to tourism and one of the oldest show cave site in the region. The basics factors of this situation are the traditional ceremonial use of caves and the national and local impulse of tourism as a focal point for economical development.

The study is realized in a participative way, so the actors of this "scenario" are active not only in providing data, but also in the definition of the main needs and guidelines of the sector as well as in the methodology of the diagnostic. The approach is based in the ISCA (International Show Cave Association) management guidelines and the IUCN protection paper, and basically will tend to define the: (a) environmental physical assessment (geology-hydrology-biology, conservation); (b) Structural assessment (trails, access, zone visits, etc.); (c) Management and security (guides, preparation, plans, etc.); (d) Socioeconomic assessment (finance, management, enterprise responsibility, type of tourist, periods of affluence). The diagnostic itself is a good opportunity to reach and educate people on the impacts of human development on karst waters and karst habitats and for this purpose a karst protection brochure is produced and distributed during the visit to the caves.

The research will be providing useful information for the INGUAT, in order to set up and develop a series of legal actions for the protection and management of the cave resources in the framework of the national ecotourism planning. The ecotourism activity is recently using caves as sites for the special guided tours and very few have the organization to provide specific education for the guides or the manager of the cave. This situation is leading to more pressure for the underground environment open to the public by increasing the direct risk for the caves, but also it is an important and unique opportunity for cave protection.

This participative studies indicates that all the communities or private organizations are extremely open to improve their knowledge and actions in a sustainable management way. This situation will lead to a second step of the intervention on the actors involved in order to provide a series of instruments such as guidelines, methodology and courses for show cave management focused on ecotourism and community management.

1. Contexto del Proyecto

Guatemala tiene una extensión de 108,889 km². Sus costas suman unos 400 km y tiene más de 1.600 km de frontera. La topografía kárstica es de unos 15.000 km² (Kuney & Day, 2002).. Los estimados de estos autores se basan en un enfoque regional para Centroamérica. Valores puntuales podrán ser establecidos a partir de posteriores investigaciones a una escala que permita mayor detalle en las

observaciones, tanto bibliográficas como de campo. Según el mapa de Clasificación de Reconocimiento de los Suelos de la Republica de Guatemala (Simmons et al., 1959) y Day en el departamento de Petén y Alta Verapaz se encuentra el 40% del karst de Centro América (Day, 2007) (Fig. 1).

Los departamentos del Petén, Alta Verapaz y la parte norte de Baja Verapaz hay un alto porcentaje de población



Figura 1: Zonas kársticas de Guatemala (en negro), karst basado en Simmons (Simmons et al., 1959). En el recuadro se encuentra el contexto geotectónico.

indígena (Adams, 2002) y hay evidencias de investigaciones directas del uso ceremonial de las cavernas en la región. Esta ancestral relación con el mundo subterráneo es muy importante para las poblaciones del área maya y se basa en la mitología, simbolismo y ritual ligado a las cavernas hasta la época moderna (Bonor Villarejo, 1989).

Le economía de Guatemala ha dependido fuertemente de los “productos agrícolas de exportación” y ha sido afectada seriamente por la fluctuación de los mercados internacionales. En este contexto, es crucial la diversificación de las actividades económicas para que Guatemala logre mantener una economía estable y el desarrollo del turismo representa una fuente valiosa de crecimiento económico.

Las cavernas representan un destino turístico importante para el INGUAT y se requieren datos en cuanto al estado actual, nivel de protección, conservación y la gestión de las mismas para obtener una apreciación integral en línea

uno de los principios guías de la Unión Internacional para la Conservación de la Naturaleza y los Recursos Naturales UICN (Watson et al. 1997) en cuanto a manejo y protección de las cuevas y del karst.

2. Contexto Geotectónico

La actividad tectónica actual de Centro América es extraordinariamente rica y variada, donde la tendencia fisiográfica está definida por la trinchera mesoamericana y un arco volcánico, activo desde la iniciación de la subducción en el Cretácico Tardío. Guatemala se ubica en la parte norte de Centroamérica (Dengo, 1969; Dengo & Bohnenberger, 1969) la cual se puede dividir en los bloques Maya y Chortis (Fig. 1) ambos bloques contrastan en su carácter litológico y se encuentran separados a lo largo de la Falla Motagua, la cual se extiende desde el Océano Pacífico hasta el Mar Caribe por casi 400-km en dirección Este-Oeste, en su parte oriental y central de Guatemala está marcada por el valle del río Motagua que en su extensión occidental tiene una

cobertura volcánica Terciaria (Beccaluva et al., 1994).

3. Geomorfología Karstica

En la región noreste del país, principalmente en los departamentos de Petén y Alta Verapaz se desarrollan las principales regiones kársticas que incluyen karst cónico (*cockpits*) y mogotes, desarrollados en rocas calcáreas del Cretácico (Day, 2007). En esta zona el karst se desarrolla en una plataforma elevada (100-m a 200-m) que corresponde a la extensión sur de la plataforma de Yucatán (Day, 2007). Esta meseta plana está cubierta en el norte por karst al descubierto mostrando un paisaje de colinas llanas de karst (típico de los ambientes tropicales) que culmina en las Montañas Maya; y hacia el sur es más montañosa y presenta innumerables colinas kársticas.

Las montañas Guatemaltecas al norte de la falla Polochit están dominadas por carbonatos Pérmicos y Cretácicos, particularmente en la Sierra de los Cuchumatanes, una prominente meseta carbonatada que alcanza una elevación máxima de 3786 msnm (una de las más altas de Centro América) y se ubica en el departamento de Huehuetenango; y en las montañas del Mico, en el este del departamento de Izabal (Day, 2007).

El karst también se encuentra desarrollado en calizas del Mioceno a lo largo de la costa Caribe, en el este de Guatemala (Day, 2007).

Varias de las calizas del Cretácico son brechosas (Blount & Moore, 1969) y pueden asociarse a facies depositacionales, tectonismo, por colapso asociado a disolución, asociadas al evento K/T, colisión de placas y/o eventos volcánicos (Day, 2007) sin embargo la relación entre estas brechas y la morfología kárstica asociada no ha recibido la adecuada atención (Day, 2007).

4. Hidrología

En la mayor parte del norte de Guatemala, el sistema de drenaje no es completo, pues las corrientes de agua y grietas subterráneas son comunes. La mayoría de los ríos fluye principalmente hacia la vertiente del Golfo de México, incluyendo los ríos San Pedro, Usumacinta, La Pasión, Salinas, Xalcbal, Ixcán, Pojóm, Nentón y Selegua. El resto del área, desagua en el Mar de las Antillas a través de los Ríos Polochic, Cahabón y Sarstún.

Localmente, la configuración recta o rectilínea de algunos segmentos de los ríos revela el acomodamiento de las corrientes fluviales a accidentes tectónicos. Esta parte está controlada por estructuras geológicas, las cuales motivan

un espaciamiento angular paralelo o casi paralelo de las corrientes fluviales debido a fallas y pliegues (Mollinedo, 2005).

Respecto al drenaje subterráneo, la configuración natural del drenaje varía en función de la litología presente, de paralela y colinear en algunos lugares a kárstica con drenaje alternadamente superficial y subterráneo (Chiquin & Machorro, 2005). El drenaje kárstico se caracteriza por la presencia de ríos ciegos, sumideros y cañones profundos (Mollinedo, 2005).

5. Diagnóstico: Planificación y Efectos

El diagnóstico de las cavernas abiertas al turismo en Guatemala representa para el Instituto Guatemalteco de Turismo INGUAT y un instrumento base para las evaluaciones en cuanto a: gestión, planificación, protección natural y cultural (en colaboración con otras entidades del Estado) y promoción.

El proyecto Instituto Centroamericano de Estudios Karsticos y Espeleológicos ICEKE es una red de organizaciones que ofrece capacitaciones y apoyo para el estudio de cavernas y áreas kársticas en Centro América, entre sus objetivos se encuentran la formación de personal de instituciones públicas que velan por la gestión y protección de los recursos naturales.

El diagnóstico participativo consta de dos acciones fundamentales: un estudio con enfoque participativo y un taller de gestión de datos de cavernas con el uso del software Speleobase para facilitar el apropiado registro y seguimiento de la integración de datos (actualizaciones, nuevas cavernas, GIS etc.) y el estímulo de una acción de preservación de cavernas en Guatemala.

6. Aspectos de la Metodología de Diagnóstico

Un diagnóstico participativo no solamente tiene como objetivo una recolección razonada y orgánica de datos si no que al mismo tiempo pretende organizar y unificar las actividades de la comunidad tras líneas de acción debidamente analizadas y convenidas (Geilfus, 1987). En síntesis, el diagnóstico participativo debe sustentarse en los siguientes principios éticos fundamentales:

- Profundamente participativo.
- Enfoque de género.
- Consideración intergeneracional.
- Relevante.
- Flexible.
- Diseñado expresamente para la comunidad

- específica.
- La información sobre el lugar debe tener sustento documental.
- Tendencia al rescate cultural.
- Procesos de comunicación dialógicos.
- Circunscrito a la realidad local.

Para la aplicación de esta metodología al diagnóstico de cavernas, y considerando la importancia religiosa de las mismas en las culturas locales, se incluye un elemento mitológico que impone la realización de una actividad ceremonial como parte de las acciones de participación local.

La metodología específica para la evaluación de un sitio subterráneo o caverna se fundamenta en los siguientes ejes con un enfoque de desarrollo sostenible económico y ambiental (Burri & Cigna, 2000): 1) Evaluación físico ambiental (geología-hidrología-biología-conservación) 2) Evaluación estructural (recorridos, acceso, zona visitas, etc.), 3) Evaluación gestión y seguridad (guía, preparación, planes, etc.), 4) Evaluación Socio-económico (finanzas, gestión, responsabilidad empresarial, tipo de turista, periodos de afluencia).

Los principales parámetros que se evalúan son ilustrados en la Tabla 1 y se utilizan para el análisis cualitativo y cuantitativo de datos.

El diagnóstico participativo se desarrolla por las siguientes etapas: (a) Análisis datos bibliográficos, (b) Selección de cavernas a visitar; (c) Organización logística diagnóstico; (d) Visitas de campo exploratoria; (e) Diagnóstico de campo y empoderamiento del proyecto con los actores locales; (f) Taller de gestión de datos de cavernas con Speleobase; (g) Análisis de datos; (h) Elaboración de datos; (i) Redacción informes intermedio y final; (l) Seguimiento de las

actividades con el ICEKE.

En todas estas etapas y en particular en la fase de preparación del trabajo y de estudio de campo participan los actores institucionales así como los gestores de los sitios turísticos y las comunidades locales. Se han identificados 16 sitios (Tabla 2) de prioritaria importancia para el INGUAT y las comunidades locales canalizadas a través de los Comités de Autogestión Turística.

7. Resultados y Conclusiones

Según datos preliminares se han identificados tres áreas críticas: **infraestructura, formación y gestión** relacionadas con una falta de atención específica a los criterios de manejo de cavernas turísticas. Por otro lado las primeras entrevistas con los actores evidencian un elevado interés en recibir apoyo en las tres áreas concretas con énfasis en la formación y al respecto de la relación ancestral con el mundo subterráneos. La intervención para la mejora de la infraestructura se debe orientar en la búsqueda de potenciales recursos orientados a este tipo de acciones con la imprescindible consideración que se deben realizar evaluaciones de impacto ambiental. En este sentido se recomiendan el uso de tecnología de iluminación a baja emisión energética para evitar una contaminación térmica de las cavernas así como el uso de fuentes de energías renovables para proveer de energía los sistemas de iluminación fija o personal utilizados.

Estas acciones apuntan exactamente al criterio de adaptabilidad de la industria del turismo en cavernas mencionado recientemente por Cigna. (Cigna, 2008) evidenciando una adaptación sea a las nuevas tecnologías disponibles sea a los aspectos ancestrales de la cultura local.

Una fortaleza de este proyecto de estudio al turismo en

Parámetros Físicos	Parámetros estructurales	Parámetros de gestión	Parámetros Socio económicos
Geología	Accesibilidad Cercanía a un Centro Urbano de apoyo	Rotaciones en un tiempo determinado, cantidad máxima del grupo	Usos para ceremonias
Hidrología	Restricciones de propiedad (terrenos privados)	Tipo de Demanda y facilidad de recorrido	Formación del personal
Biología	Distancia de los recorridos versus recorrido total	Zonificación: zonas de turismo o espeleología	Manejo del guía.
Clima subterráneo	Instalaciones: externas - internas	Plan de seguridad y de manejo	Personal directamente involucrado
Ambiente externo	Tipo de recorrido (Material -estado)	Señalización: principalmente para evitar accidentes y accesos a zonas	Auto evaluación de impacto económico
Estado de conservación	Tipo de iluminación		Tipo de administración

Tabla 1: Tabla de los principales parámetros de evaluación (elaboración de los autores).

Nombre	Departamento /Municipio	Actividades que se realizan	Propiedad	Manejado por
1. Chicoy	Baja Verapaz: Purulhá	Se realizan Ceremonias/Sitio Sagrado-Altar de los Mayas	Privada	Comunidad de Chicoy
2. Chitul	Alta Verapaz/ Santa Cruz Verapaz	Sitio Sagrado donde se realizan ceremonias	Municipal	Comunidad Chitul
3. Rey Marcos	Alta Verapaz/ San Juan Chamelco, Comunidad Cecilinda	Caminatas dentro de la cueva	Privada	Administración privada
4. Candelaria	Alta Verapaz/ Raxruha	Ceremonias, caminatas dentro de la cueva Candelaria es un complejo de varias cuevas que pertenecen al mismo sistema y cada parte del sistema es administrado por distintas comunidades.	Administración privada.	Administración privada
5. Venado Seco	Alta Verapaz/ Raxruha	Ceremonias, caminatas dentro de la cueva. Pertenecce al mismo complejo que Candelaria	Comunidad	Comunidad Mucb'ilhá
6. Candelaria Camposanto	Alta Verapaz/ Raxruha y Chisec	Ceremonias, caminatas dentro de la cueva.	Comunitario	Comunidad local
7. B'omb'ilPeck	Alta Verapaz/ Chisec	Ceremonias, caminatas, rappel, pinturas rupestres.	Comunidad	Comunidad local
8. Hul ik	Alta Verapaz/ Chisec	Ceremonias, caminatas.	Comunidad	Comunidad local
9. Faisan	Alta Verapaz/ Cobán	Actividades: ceremonias, caminatas.	Comunidad	Comunidad local Rochá Pomtila
10. Lanquín	Alta Verapaz/ Lanquín	Ceremonias, caminatas.	Municipal	Municipalidad local
11. Yaxlik	Alta Verapaz/ Lanquín	Ceremonias, caminatas.	Propiedad privada	Administración privada. Ingresar con previo aviso.
12. Zetzol	Alta Verapaz/ Chahal	Ceremonias, recorridos.	Propiedad privada	Comunidad de Zetzol. (la cueva es de propiedad privada pero lo maneja la comunidad)
13. Lagunas de Sepalau	Alta Verapaz/ Chisec	Kayak, nadar, paseos en lancha de remos	Comunitario	Comunidad local

14. Samac	Alta Verapaz/ Cobán	Rituales y Ceremonias Mayas	Propiedad privada	El complejo es manejado por la Cooperativa Samac
15. Naj Tunich (Casa de Piedra)	Petén/Poptún	Recorridos, sitio ceremonial, punturas rupestres.	Ministerio Cultura y Deportes	Ministerio Cultura y Deportes
16. Actún Can	Petén/Flores, aldea Santa Elena	Recorridos, sitio ceremonial.	Municipal	Una ONG

Tabla 2: Sitios prioritarios identificados.

cavernas se debe al hecho que se han creado vínculos con las actividades que se desarrollan en el área de las Verapaces y El Petén con la participación de la Agencia de Cooperación Técnica del Japón JICA, a través del “Proyecto de Cooperación Técnica para el Desarrollo de las Capacidades de los Comités de Autogestión Turística en Guatemala” en donde uno de sus objetivos es fortalecer la capacidad de gestión de los Comités de Autogestión Turística y promover el turismo, con base en los recursos locales en las áreas de las Verapaces y El Petén.

Los actores locales como el Instituto Guatemalteco de Turismo INGUAT, los Comités de Autogestión Turística CAT’s, la Cámara de Turismo de Guatemala CAMTUR, junto con las comunidades locales, participan activamente, en la fase del estudio en el aspecto logístico y económico, haciendo de este proyecto una experiencia mancomunada donde cada organización contribuye activamente.

El ICEKE contribuye con personal (espeleólogos y geólogos) y con esta iniciativa espera dar un considerable aporte al desarrollo de una información estructurada para que se inicie una catalogación y estudio de todas las cavernas en Guatemala, razón por la cual la realización del taller “Speleobase” es parte de la metodología de diagnóstico participativa. El proyecto ICEKE así fortalece sus capacidades y la funcionalidad de la red entre espeleólogos de la región y organismos que se interesan al progreso de la misma.

Es preciso enfatizar que el diagnóstico se enmarca en una serie de actividades para la protección de los recursos subterráneos en esta región tales como: el segundo congreso centroamericano de espeleología II CCE dedicado al MANEJO SOSTENIBLE CAVERNAS TURISTICAS y el proyecto EduKarst (www.proiceke.blogspot.com).

Para el INGUAT el diagnóstico es un instrumento para definir prioridades y organizar acciones tales como: cursos para guías de cavernas turísticas; taller de gestión sostenible de cavernas turísticas para administradores, actividades de exploración de cavernas en Petén, Alta Verapaz y Baja Verapaz.

Referencias

- Adams R.N., 2002. Etnicidad e igualdad en Guatemala, Naciones Unidas Comisión Económica para América Latina y el Caribe. División de Desarrollo Social, UN. ECLAC. Social Development Division, Economic Commission for Latin America and the Caribbean, by United Nations Publications.
- Beccaluva, L. Bellia, Coltore, Dengo, Giunta, Romero, Rotolo y Siena, 1994. El borde noreste de la placa caribeña en Guatemala. Guatemala, Ministerio de Energía y Minas/ICAITI 15 p.
- Bonor Villarejo, J. L. 1989 Las Cuevas Mayas: Simbolismo y Ritual. Universidad Complutense de Madrid, Instituto de Cooperación Iberoamericana, Madrid.
- Blount, D.N. and Moore, C.H. (1969) Depositional and non-depositional carbonate breccias, Chiantla Quadrangle, Guatemala. Geol. Soc. Am. Bull. 80, pp429–442
- Burri E. & Cigna A., 2000 - Development, management and economy of show caves. Int. J. Speleol., 29 B (1–4): 1–27.
- Cigna, A., 2008. The Development and Management of Show Caves. ISCA (International Show Cave Association), obra no publicada.

- Chiquin, L.; Machorro, R. 2001. Caracterización geológica del Carso en la porción Sur de Alta Verapaz, Guatemala. In IV Congreso de Geología y Minería./ IV Taller Internacional de Geociencias y Medio Ambiente. La Habana, Cuba. Sociedad Cubana de Geología. 8p.
- Day, M.J. (2007) Karst landscapes. In: Bundschuh, J. and Alvarado, G.E., (eds): Central America: geology, resources and hazards. Ed. Taylor & Francis, London, UK.
- Dengo, G. (1969) Problems of tectonic relations between Central America and the Caribbean. Trans. Gulf Coast Geol. Soc. 19 pp.311-320.
- Dengo, G. and Bohnenberger, O. (1969) Structural development of northern Central America. In: A.R. McBirney (ed): Tectonic Relations of Northern Central America and the Western Caribbean: The Bonacca Expedition, Memoir 11. American Association of Petroleum Geologist, Tulsa, 1969, pp.203-220.
- Geilfus, F. 1987. 80 herramientas para el desarrollo participativo: diagnostico, planificación monitoreo, evaluación. Prochalate, El Salvador. IICA. 208 p.
- Kuery J.A. and Day, M.J. 2002. Designation of protected karstlands in Central America: A regional assessment. Journal of Cave and Karst Studies 64(3): 165-174.
- Mollinedo, N. 2005. Caracterización Geológica del Karst en los cuadrángulos Caquipec y Senahú. Tesis no publicada. Carrera de Geología, Centro Universitario del Norte, Universidad de San Carlos de Guatemala.
- Simmons, C.S., J.M. Tarano T., and J.H. Pinto. 1959. Clasificación de Reconocimiento de los Suelos de la Republica de Guatemala, Ministerio de Agricultura, Guatemala City, 1000 pp
- Watson, J., Hamilton-Smith, E., Gillieson, D., & Kiernan, K., (eds.), 1997, Guidelines for cave and karst protection: IUCN, Gland, Switzerland and Cambridge, UK, 63 p.

EXPLORING KARST IN GOOGLE EARTH: A TOOL FOR EDUCATION AND SHARING INFORMATION

KATARINA Z. DOCTOR¹, DANIEL H. DOCTOR²

¹*Department of Geography and Geoinformation Science, George Mason University,
4400 University Drive, MS 6C3, Fairfax, VA, 22030, USA*

²*Virginia Cave Board, 12201 Sunrise Valley Drive, MS 926A, Reston, VA, 20192 USA*

Many scientific, social and environmental issues related to karst reach across the globe. Commonalities and differences among geographically diverse karst areas are not easily understood by most people until they are provided some sort of visual context. Using the power of 3D visualization and virtual globe technology, such as Google Earth, the general public is better able to relate to and understand the complex geography of karst. Such complexity may exist in their immediate neighborhood, or extend to another region of the world that is hard to visualize. Tools currently available within Google Earth enable virtual terrain exploration, sharing of photographic imagery, videos, links to a host of additional sources of information, and simple tools for spatial analysis.

There are numerous ways to display and share information about karst terrains using Google Earth in order to provide visual context to issues of regional geographic importance. Themes of visualization include the fantastic and beautiful landforms of karst themselves, hazards associated with karst, and issues of karst resource conservation and study. Through presentation in virtual globes, information can be easily provided to the general public, and may raise awareness of issues important to karst science.

1. Introduction

The most effective way for the general public to assimilate and understand complex scientific and environmental issues is through a visual presentation. Virtual globes have revolutionized the presentation of geographic information, greatly facilitating the ability for the general public to place large amounts of information into a spatial context, from local to global. One of the most popular virtual globes is Google Earth, a 3-dimensional geobrowser freely available to anyone with an internet connection and a computer with the minimum requirements. Google Earth is evolving toward becoming an interactive encyclopedia that contains information within a spatial context. Google Earth is very user-friendly, making its use widespread throughout the world.

2. What Is Google Earth?

The Google Earth virtual globe is covered with satellite and aerial imagery of Earth at various resolutions and scales, from space to street level (Fig. 1). Where the imagery is of high resolution, it is possible to see an individual person. One may search for geographic features using Google's search technology by entering a name of a geographic feature, address, place name, coordinates, or by simply navigating with the mouse. The built-in DEM (Digital Elevation Model) enables one to view the relief of mountains and hills when the image is tilted. The user can

fly over the terrain, pan, rotate, tilt, spin and fly to another place on the globe. Tools for measuring distances, areas, and for creating lines and polygons that the user may save on her computer are all included.

3. Information Provided in Google Earth

Google Earth provides the user numerous layers of information that can be optionally shown within the Layers panel (Fig. 2). As the user zooms in to a desired field of view, icons appear that link to additional information, such as online articles related to the location in the field of view, high resolution and panoramic photography, 3D terrain and buildings, points of interest, information related to various organizations, and other types of information which are continuously updated. For example, the layer "Global Awareness" provides icons that open to various photographs, articles, videos, or other items of interest provided by organizations through cooperation with Google Earth. Some of the layers are related to the natural world, and some are related to societal issues. Within this layer, one may find karst conservation projects listed through the World Wildlife Fund, endangered or unique species through ARKive, or satellite images illustrating land use and land cover change through the United Nations Environment Programme (UNEP) Atlas of Our Changing Environment series.

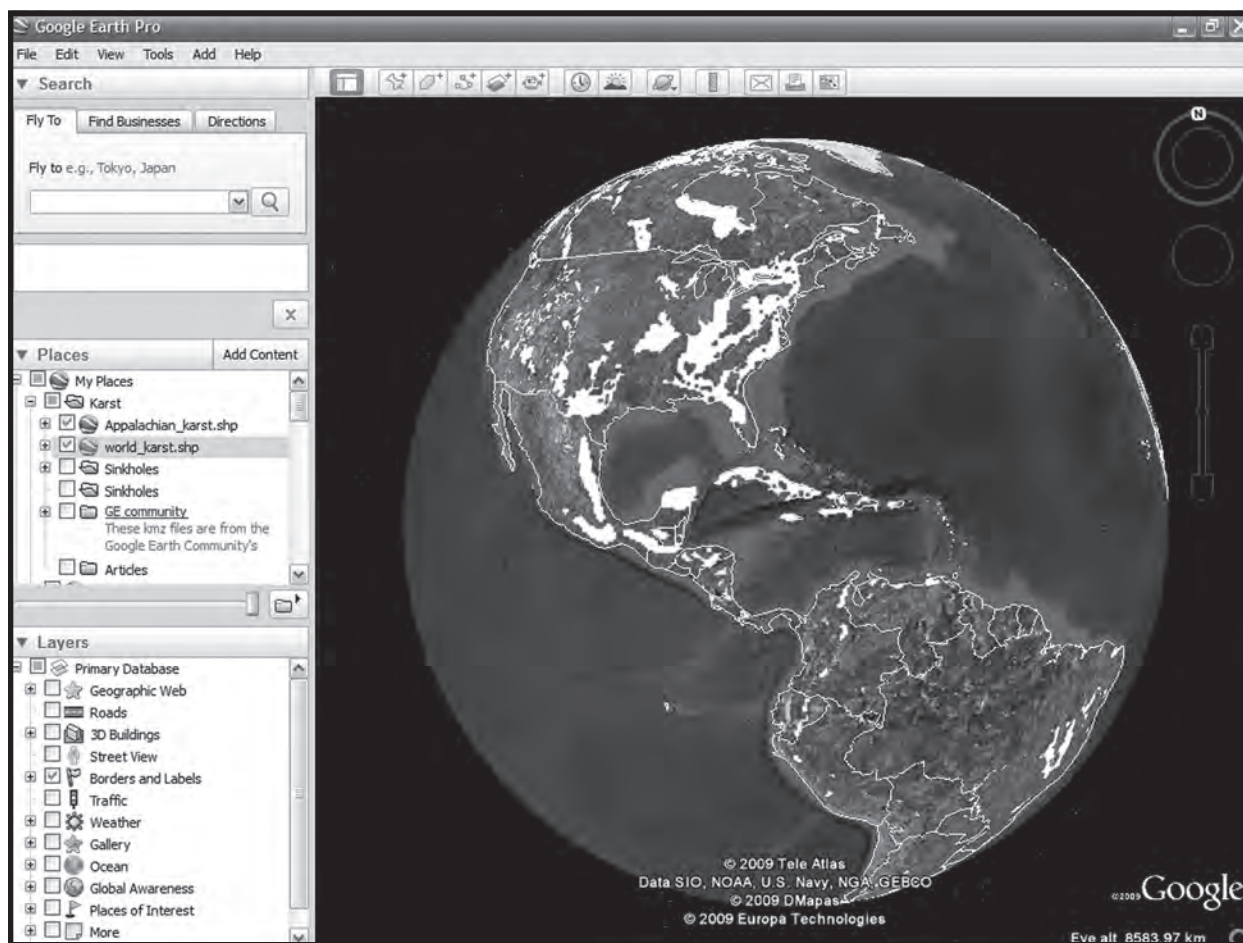

Figure 1: Screenshot of Google Earth, with karst areas highlighted in white. Data obtained from the World Map of Carbonate Rock Outcrops v3.0 (WILLIAMS AND FORD, 2006) and WEARY, 2008.

4. Adding information to Google Earth

Users can also add their own information through Google Earth Community posts. This information can be text, images, video, or links to other information on the Web. The information posted by the Google Earth Community becomes integrated within Google Earth, and is globally available. Posting to Google Earth through Google Earth Community is the most direct means of sharing your own information with the users of Google Earth around the world; however, this information will be co-mingled with all other information posted within the Google Earth Community. Currently, there are over 1 million members of the Google Earth Community and as many posts in Google Earth.

In addition, Google Earth is an excellent means of exploring more focused data through one's personal computer. Using Keyhole Markup Language (KML), users are able to mark and save points of interest within the Places panel, save them within a personal computer, and share with other users. It is also possible to import data from a Global Positioning

System (GPS) device such as waypoints or tracks. Google Earth can be used as a posting board or a medium to which we can add our own layers of data, such as shapefiles, vector data, images, weblinks, text, or 3-dimensional drawing elements. This information or layer will not appear automatically to all Google Earth users' screen, but only to those who will upload the KML file that has been created to store the information. In essence, Google Earth provides some basic functions of a Geographic Information System (GIS) for free to people around the world.

Although most information, data and images in Google Earth are of and about Earth, we can choose to virtually explore other planets, stars and the galaxies, too. In February 2009, Google Earth launched its Mars virtual globe, providing imagery, a digital terrain model, and high resolution photography obtained by satellites, landers and rovers on Mars. It is possible to see individual collapse features that may lead into lava tubes. Since the only means of visiting Mars at the moment is virtually, this virtual globe is especially educational, not to mention entertaining!

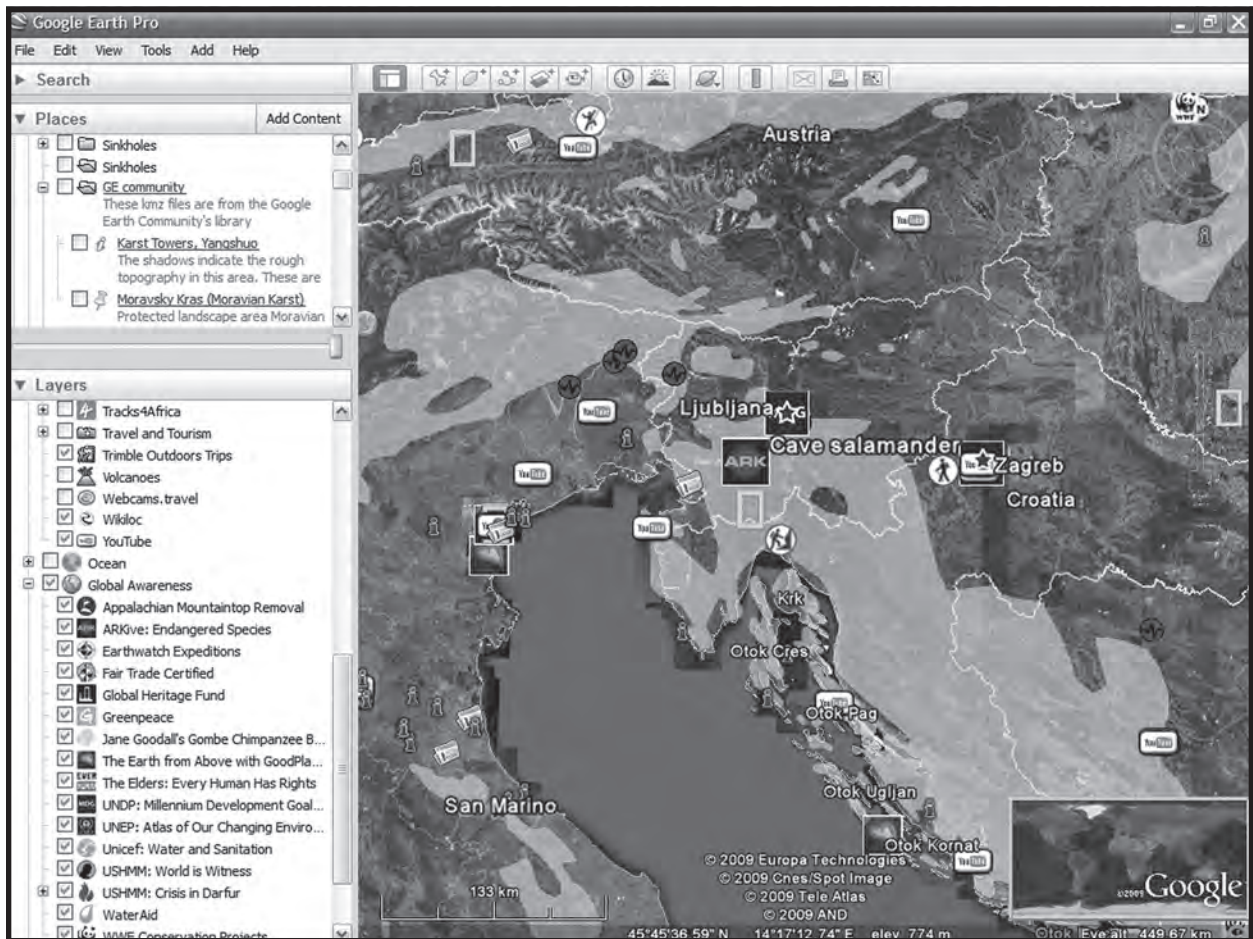

Figure 2; Screenshot of Google Earth showing the region of the northern Dinaric karst along the Adriatic Sea. Icons are links to information provided through the Layers panel, located to the left of the image. Semi-transparent areas are karst regions obtained from the World Map of Carbonate Rock Outcrops v3.0 (WILLIAMS AND FORD, 2006).

Google Earth is inherently interactive, and enables the general public to place complex issues into a visually stimulating geographic context, thus creating an extremely effective and engaging learning experience.

References:

<http://earth.google.com>

Weary, D.J. (2008) Preliminary Map of Potentially Karstic Carbonate Rocks in the Central and Southern Appalachian States. U.S. Geological Survey Open-File Report 2008-1154, 1 plate.

Williams, P., and Ford, D.C. (2006) Global distribution of carbonate rocks, *Zeitschrift für Geomorphologie Suppl.*, 147, 1–2.

PROYECTO BELLAMAR

ESTEBAN GRAU GONZÁLEZ-QUEVEDO¹, IVONNE VÁZQUEZ DE LA TORRE²

¹*Cuban Speleological Society, speleomat@atenas.inf.cu*

²*Italian Speleological Society, spleoivt@yahoo.com*

Abstract

The Bellamar Project began in 2003 as a joint venture between the Speleological Society of Cuba and the Italian Speleological Society, and the main goal is to protect the Cuban Karstic Heritage by revealing and advertising its value and importance based mainly on 3D photographic and video techniques.

In the period 2003–2008 both Societies have carried out five expeditions, working into some of the main cave systems of Cuba, among them Santo Tomás (Pinar del Río Province), Bellamar (Matanzas Province), Martín Inferno (Cienfuegos Province), Caguanes (Sancti Spíritus Province), and the underground aquifer system of the “Zapata Marshland” in Matanzas Province.

The project has made the inventory of the cenotes and karstic springs of Matanzas province in order to preserve these water resources, the survey of the Bellamar System, and several presentations at Elementary Schools, rural communities and National galleries, as part of its Environmental Education strategy. It was into the final stage of the prestigious Rolex Award for Enterprise 2006.

In 2007, a permanent 3D projections room was inaugurated at “Cuevas de Bellamar” touristic center. It makes possible that people who arrive to this place to visit the public area (5% of the whole Bellamar Cave System), are able to know the values of the underground.

US/CHINESE EFFORTS IN WATER RESOURCE DEVELOPMENT IN SOUTHWEST CHINA'S KARST REGIONS THROUGH EDUCATION

CHRIS GROVES¹, YUAN DAOXIAN², JENNIFER TURNER³

¹*Hoffman Environmental Research Institute, Western Kentucky University, Bowling Green, KY USA*

²*International Research Center for Caves and Karst, Guilin Guangxi, CHINA*

³*China Environment Forum, Woodrow Wilson International Center for Scholars, Washington DC, USA*

Abstract

Southwest China holds one of the world's greatest karst landscapes, covering some 500,000 km² over eight provinces and providing a home to 80–100 million largely rural residents. Like other parts of the world, development challenges occur there due to environmental conditions associated with karst aquifer/landscape systems, but in China's rural southwest these are especially severe. Commonly in the region's karst plateaus the water table may be hundreds or more than a thousand meters below the surface, and surface water supplies are especially limited during the prolonged winter dry season. Historically many villages in the region were established in the vicinity of small springs formed by "charging" of storage in the vegetation/soil/bedrock epikarstic zone during the summer wet season that would provide enough water throughout most winters to supply a few hundred people. However, following massive deforestation beginning in the late 1950s and the resultant hydrologic disruption and destruction of shallow epikarstic storage, many residents must walk to obtain water. This in turn has negative impacts on economic development, public health, and quality of life. Seven of the eight karst-rich provinces of China's southwest are now among the country's poorest.

Following ten years of collaborative research in karst hydrogeology and geochemistry between Western Kentucky University (WKU), the Institute of Karst Geology in Guilin China, and Southwest University (SWU) in Chongqing China, in 2006 the China Environmental Health Project (CEHP) was initiated with major support from the US Agency for International Development and the ENVIRON Foundation. Specifically, we have developed a program to improve environmental/public health conditions with regard to karst water supply through an academic partnership with SWU along with A Child's Right and the China Environment Forum at the Woodrow Wilson International Center for Scholars. Another major CEHP technical program addresses training for air quality monitoring in Anhui Province.

In the third year of the program CEHP has conducted workshops for students and scientists at SWU in technical aspects of karst water resource development, as well as established laboratories for analysis of fluorescent dyes for groundwater flow tracing and Geographic Information Systems (GIS). Two week-long workshops in current methods in karst hydrogeology have been implemented, along with others in cave surveying, Single Rope Techniques, and specialized methods in GIS. These efforts have also supported joint US/Chinese fieldwork in karst hydrogeology as a training vehicle at demonstration sites in the karst basin of Qinnuguan, Chongqing and the East Mountain Plateau of southern Yunnan.

SAY, WHAT'S A CAVE ?

DIS, QU'EST-CE QU'UNE GROTTTE?

BADR JABBOUR-GEDEON^{1,2}, GHADA SALEM¹, MAYA CHEHAB¹, SARA ZOGHBI¹, HELENE RECHMANY¹

¹Association Libanaise d'Etudes Spéléologiques – ALES. P.O. Box 31,
Mansourieh, Metn, Lebanon. www.alesliban.org

²EDYTEM laboratory, Savoie University, CISM, Scientific Campus F-73376,
Le Bourget du Lac Cedex, France.

All through International Congresses of Speleology, Brazil 2005 and Athens 2005, a theme amidst all others drew the attention of the attendees Badr Jabbour-Gedeon and Ghada Salem: Children in Caves.

In 2005, they launched a “Special Lebanese Children Project” with the collaboration of psychologist and fellow speleologist Maya Chehab, and the youngest caver of the ALES who happens to be a third-generation caver in her family, Sara Zoghbi. It is nevertheless with thanks to the participation and the personal investment of all the members of the ALES that they were able to see their project through.

This project was founded upon a speleological, historical and psychological database. With these data the team was able to establish a work plan in order to reach the desired objectives which will be mentioned during this expose, along with the different stages and the analytical study of the concerned comments.

Au cours des congrès internationaux de spéléologie, Brésil 2001 et Kalamos – Athènes 2005. Un thème parmi d'autres a retenu l'attention des participantes, Badr Jabbour-Gédéon et Ghada Salem: celui des enfants dans les grottes. En 2005, elles ont lancé un projet spécial enfants avec une psychologue spéléologue, Maya Chehab, et la plus jeune spéléologue de l'ALES, elle-même étant issue de la 3^{ème} génération de spéléologues dans sa famille, Sara Zoghbi. Cependant, c'est grâce à la participation et l'investissement de tous les membres de l'Association Libanaise d'Etudes Spéléologiques - ALES qu'elles ont mené ce projet qui a conduit le club vers une nouvelle destination : celle de former un noyau de jeunes spéléologues dès leur plus jeune âge...

Ce projet s'est fondé sur une base de données spéléologiques, historiques et aussi psychologiques. C'est à partir de ces données, que l'équipe a pu établir un plan de travail afin atteindre les objectifs désirés:

1. Objectif

- 1- Familiariser les jeunes avec le milieu souterrain (formation pédagogique et technique, sensibilisation aux ressources naturelles et à leur protection),
- 2- Leur donner une image simplifiée et complète de l'ensemble des activités spéléologiques,
- 3- Déterminer le rôle du spéléologue,
- 4- Freiner la destruction involontaire du milieu souterrain,
- 5- Supprimer les idées reçues et les récits mensongers,
- 6- Interagir avec les jeunes : apprendre en pratiquant,
- 7- Participer à des projets de nettoyage du milieu souterrain,
- 8- Favoriser l'interactivité au sein du groupe: responsabiliser.
- 9- Passer l'information à l'enfant dont le jeune âge le rend facilement perméable à cette campagne de sensibilisation pour en faire un fervent défenseur du monde souterrain dans son contexte naturel, et éventuellement un futur véhicule de ces informations,
- 10- Vulgariser la connaissance du monde souterrain au grand public à travers les jeunes générations visant à surmonter la peur instinctive que peut provoquer le monde souterrain chez ceux qui l'ignorent.

Cible: Jeune population libanaise
Tranches d'âge: 5-11 ans et 12-18 ans

Étapes du projet:

Phase 1:

Afin de pouvoir mettre ce projet sur la bonne voie, un plan a été établi et a été suivi à la lettre dès le début:

- 1- Diffuser le projet à l'échelle nationale (Clubs spéléologiques libanais actifs).
- 2- Choisir les tranches d'âge des enfants sujets de l'étude.
- 3- Diviser les tranches d'âge en 2 catégories: Enfants familiarisés à la spéléologie – Non familiarisés à la spéléologie.
- 4- Organiser une sortie témoin sur le terrain.
- 5- Analyser les rapports écrits par les enfants.
- 6- Evaluer la technique appliquée.
- 7- Elaborer une technique d'approche plus pertinente et appropriée aux âges concernés.

En 2006, les 4 membres de l'ALES ont exposé les premiers résultats du projet dans une conférence intitulée «Dis, Qu'est-ce qu'une grotte?» lors du Deuxième Symposium de spéléologie du Moyen-Orient (MESS2). Le but de cette étude étant de trouver un moyen pédagogique et durable afin d'assurer la préservation du patrimoine karstique du pays. L'idée s'est développée dans la salle-même de conférence lorsque le comité international a encouragé les conférencières à poursuivre leur entreprise en insistant sur le fait que le groupe est précurseur de ce genre de thème en espérant une réussite locale puis internationale.

Phase 2:

Un deuxième plan a été aussitôt établi pour cette seconde étape:

- 1- Garder la même équipe d'enfants, évaluer la technique d'approche.
- 2- Echanger les informations et les impressions entre les enfants et les encadreurs du projet.
- 3- Motiver les enfants en assurant leur propre équipement de base.
- 4- L'enfant apprend et applique de façon ludique les techniques et préparations (matérielle et psychologique) nécessaires à la pratique de la spéléologie.

Premier Bilan: L'enseignement passe inaperçu et l'enfant atteint les objectifs fixés (tels que: comportement

responsable à l'égard du lieu, de lui-même et des autres).
 PRESERVER AMUSE

Phase 3:

Exposition des données

Enfants familiarisés à la spéléologie (15 enfants)

Enfants non familiarisés à la spéléologie (18 enfants)

2. Quelques témoignages:

A- Groupe Pierre Matta (10 ans d'activité spéléologique), 3 neveux: «l'enthousiasme de mes neveux a reflété mes sentiments il y a dix ans. Ma passion s'est étalée sur cette période déjà, j'espère la transmettre à mes neveux ainsi qu'à mes enfants ».

Toni Saad, âge 10 ans et demi

«J'ai visité sept fois les grottes avec l'ALES (la grotte de Roueiss et la grotte de Jiita - Salle rouge). J'aime visiter les grottes. Dans la grotte de Jiita, J'ai beaucoup aimé le tunnel et les rails en fer des wagons, la promenade dans le dinghy, les stalactites et stalagmites. Waw! Dans la grotte de Roueiss j'ai beaucoup aimé la descente sur les cordes, l'escalade sur les rochers et les sympas chauves-souris. J'aimerais continuer la spéléo et devenir membre de l'association. Le groupe s'occupe beaucoup de nous et ce que j'aime le plus quand ils me donnent des responsabilités envers mes amis. Toute l'équipe s'aime beaucoup. Je suis allé au club pour apporter du matériel: les casques, les cordes et les mousquetons de la magnifique chambre de matériel du club. Dans le village de Faytroun, j'ai vu les membres de l'association s'entraîner. Je veux moi aussi».

Stéphanie Saad, âge 8 ans

«J'ai visité 3 fois la grotte de Roueiss. J'aime beaucoup visiter les grottes parce qu'on apprend beaucoup de choses, j'aime l'aventure et j'aimerais continuer la spéléo et devenir un membre de l'association. Le groupe s'occupe de nous et nous aide à grimper les rochers, à monter les échelles et utiliser les cordes. Les gros rochers dans les grottes sont impressionnants. Les concrétions sont magnifiques. Dans la grotte il y a plein de chauves-souris qui restent dedans. J'ai appris que les chauves-souris ne font pas de mal ».

Georgio Matta, âge 6 ans

«Je suis allé deux fois à la grotte de Roueiss. J'ai aimé la grotte parce qu'il y a de l'eau et on descend sur la corde, Beaucoup d'aventure. J'aimerais aller une autre fois et être

membre de l'association. Le groupe est formidable et nous donne beaucoup d'information sur les grottes».

B- Groupe Samer Amahz (14 mois d'activité spéléologique), sa sœur «J'aime initier ma sœur à toutes les activités sportives et culturelles que je pratique. J'ai pu surpasser la peur de mes parents à travers sa participation et surtout son exaltation».

Farah Amhaz, âge 13 ans

«C'était la troisième fois que je visite une grotte au Liban.

Ma première visite, dans une grotte, était à Jiita avec mes parents. La grotte était aménagée et illuminée par des projecteurs. Mes deux autres sorties étaient à la grotte de Roueiss et à la grotte de Kanaan, avec l'ALES. J'ai pensé qu'elles étaient pareilles à Jiita. J'ai été surprise de les trouver encore dans leur état naturel. J'ai vu des concrétions, des chauves-souris, j'ai marché sur le sol de la grotte et escaladé des blocs. J'ai eu un peu peur lors de l'escalade mais j'étais tout le temps encadrée par les membres de l'association. J'étais équipée avec un matériel convenable : casque, éclairage...

Je me sentais libre.

J'ai beaucoup aimé la visite des grottes. C'était une très belle aventure que je souhaite refaire. J'encourage tous mes amis à visiter des grottes».

C- Groupe Zeina Wazein Abdelmalak (courte période d'activité spéléologique),

deux fils: «J'espère transmettre mon amour à la spéléologie à mes enfants. A mon sens, je me suis rapprochée de la nature grâce à cette activité».

Emilio Abdelmalak, âge 9 ans

«J'ai vu que les grottes sont pleines de boue et certaines contiennent de labyrinthes. Il y a beaucoup de l'eau, il y a beaucoup de chauves-souris. J'ai trouvé une échelle qui emmène à un grand lac dans la grotte de Mabaage. J'ai compris qu'il ne faut pas salir la grotte. J'ai appris qu'il ne faut jamais s'éloigner du groupe. Je voudrais faire partie de l'association ALES. J'aime la spéléo à bientôt.»

Rayan Abdelmalak, âge 6 ans et demi

«J'ai vu qu'il n'y a pas beaucoup de places pour marcher. Il y a beaucoup de stalactites et de stalagmites. Il y avait des bougies pour ne pas tomber et trouver le chemin. J'ai cherché un X pour trouver le trésor caché mais je n'ai rien

trouvé. Le père Noël est venu dans la grotte de Roueiss et a distribué des cadeaux. Il faut rester avec nos amis pour ne pas perdre le chemin. Je veux faire partie de l'ALES.»

D- Groupe Fadi Dagher (6 ans d'activité spéléologique), un fils: «C'est formidable que mon fils aime ce que j'aime».

Vincent Dagher, âge 6 ans

«J'étais très heureux de passer une journée magnifique avec des enfants de mon âge. Nous sommes entrés dans une grande grotte «Roueiss». C'était beaucoup amusant. Papa a joué de l'harmonica, il y avait aussi un clown et le père Noël. Merci à tous les ALES. Je vous aime beaucoup.»

E- Groupe Hélène Rechmany (12 ans d'activité spéléologique), cinq petits cousins : «Je profite de la confiance qu'ont les parents de mes petits cousins ont en moi pour prendre leurs enfants à chaque fois que l'occasion me permet afin de participer à l'une ou l'autre des activités de l'ALES. Les enfants à chaque fois que je les vois, en fait très fréquemment, me pressent de les emmener encore une fois dans une grotte. Ils sont devenus plus accros à la spéléo que moi».

Farès Alouf, âge 10 ans

«La grotte de Roueiss, c'est là où je suis entré Au mois d'août j'y ai pénétré

Les stalagmites et les stalactites plus grandes que jamais Dans la montagne, elle est située

Ah! Quelle belle grotte! Immense et majestueuse

Mon seul souhait, c'est de toujours y aller

Ah! Quelle belle grotte!!!

PS: si vous voulez y aller, conseil, éviter de porter des espadrilles neuves et prenez des habits de rechange. Ça vous sera utile.»

F- Groupe Julianna et Rany Sfeir (5 ans d'activité spéléologique), deux enfants:

Yasmina Sfeir, âge 8 ans

Je m'appelle Yasmina, j'ai 7 ans. Mon frère s'appelle Rayan et nous sommes des faux jumeaux. Nos parents étaient des spéléologues à l'ALES.

Avec l'ALES, nous avons participé à plusieurs sorties; depuis

déjà trois ans, nous fêtons le réveillon de Noël à la grotte de Roueiss.

Pour arriver à l'entrée de la grotte, on fait de l'escalade. Une fois à l'intérieur, divisés en petits groupes et bien encadrés par les membres de l'ALES, nous faisons un petit tour de la grotte; là, passant d'un boyau à un autre, croisant stalactites et stalagmites, on arrive à une grande salle où les groupes se rassemblent pour attendre l'arrivée du Père Noël qui distribue pour chacun des cadeaux.

Chaque année, nous attendons cet événement avec impatience.

G- Groupe Mireille Tabet (Meilleure amie de Badr Jabbour-Gédéon) un fils: «Malgré que les sorties spéléologiques consacrées aux enfants sont organisées par une proche amie que je connais depuis plus de 17 ans, un sentiment de peur envahit mon esprit à chaque fois qu'elle proposait à mes enfants de participer à ces sorties. Néanmoins, l'excitation et l'enthousiasme de mon fils m'ont encouragé à le confier, finalement, à Badr. A son retour, il était tellement heureux que j'ai senti avoir tort de m'inquiéter ».

Farès Tabet, âge 10 ans et demi

J'avais très peur de la grotte parce que je ne suis jamais rentré donc je ne savais rien de quoi il s'agit. Cependant, je voulais savoir qu'est ce qui va se passer surtout que je suis aventurier de nature. Ce que j'ai aimé le plus c'est que j'étais responsable de moi-même. Le plus remarquable c'est la distribution des bougies partout. Waw! C'est impressionnant, mais j'ai fait beaucoup attention à mes amis de la flamme du casque. Le toboggan de boue était trop cool! On glissait, on patinait comme des fous c'était sympa! J'ai aimé l'ambiance, la bouffe et les cadeaux de Noël. J'aime beaucoup encourager ma sœur, mes cousines et mes cousins à participer à des sorties organisées par l'ALES dans les grottes.

3. Analyses et interprétations de Maya Chehab (Spéléologue et psychologue)

Nous sommes de ceux qui pensent que le monde souterrain de notre planète est le reflet du monde qui existe en surface, et vice-versa... Nous ne pouvons donc préserver l'un sans l'autre. Il s'agit donc d'éduquer nos enfants afin qu'ils puissent le connaître, le comprendre, le respecter et le protéger. C'est un joyau caché: apprenons-le à nos enfants...

Le vécu des enfants face au monde souterrain est très intéressant à observer, avant tout parce qu'il reflète la

conception qu'en ont la société en général, et leurs parents en particulier. Dans nos analyses et interprétations, nous nous baserons principalement sur deux niveaux de réflexion: le niveau **affectif** et le niveau **intellectuel**.

Précisons premièrement que l'objectif principal de notre approche est d'amener nos enfants à une connaissance plus adaptée du monde souterrain. Notre équipe a donc très tôt pris conscience qu'il nous fallait non seulement sensibiliser les enfants à travers des apprentissages éducatifs, mais également aborder leur vécu émotionnel et imaginaire de la grotte... Pourquoi? Tout simplement parce que ces idées, ces fantasmes et ces rêves demeurent dans les esprits, et que nos enfants les transmettront aussi un jour aux leurs...

Approche du vécu affectif de la grotte par l'enfant:

Écoutons les enfants parler a priori, c'est-à-dire avant toute expérience, des grottes et des gouffres. On perçoit une fascination certes, mais aussi une angoisse, une inquiétude, mêlée à une grande curiosité...

En psychologie, le concept de «grotte» est défini comme un élément contenant; et tout élément contenant peut avoir deux portées complètement opposées: il peut en effet être vu comme bon, enveloppant et protecteur, mais peut aussi avoir une signification plus négative, être vécu comme étouffant, dangereux, qui engloutit et qui avale, etc. Quand un enfant, ou même un adulte, visite une grotte pour la première fois, il est naturel que toutes ces pensées se bousculent dans son esprit; ce sont d'ailleurs ces idées-là qui détermineront avant tout la manière dont il vivra cette visite. Toutes les expériences concrètes que la personne accumulera ensuite ne l'affecteront qu'au deuxième plan.

Toujours sur le plan affectif, et mise à part la relation qu'entretient le sujet avec le «contenant», d'autres éléments entrent en jeu dans les idées préconçues que l'enfant se fait sur le monde souterrain; ce sont les contes et récits, les films et dessins animés, et aussi, le *discours des grands*... Tous ces facteurs viennent nourrir l'imaginaire de l'enfant, et renforce le sentiment premier qu'il avait éprouvé, c'est-à-dire soit sa peur d'être pris au piège, séquestré, englouti, ou soit son désir d'être à l'abri, protégé, et enveloppé... Bien sûr, ces deux sentiments peuvent très bien coexister, seulement, l'un est toujours vécu de manière plus intense que l'autre...

Idées en vrac:

Sur le plan affectif:

- Idées préconçues, imagination, contes et récits (manque d'oxygène, monstres cachés, chauves-souris maléfiques, lieu dangereux, sombre, étouffant «qui avale», fantasme du lieu difficile d'accès où se trouvent des trésors enfouis là...
- Milieu intact, vierge, mystérieux, archaïque et dangereux.
- Angoisses parentales rationnelles ou irrationnelles transmises aux enfants: peur que la grotte ne soit noyée par les eaux de pluie, peur d'animaux sauvages, de malfaiteurs cachés des autorités (fantasme Ben Laden), peur que la grotte ne s'effondre.

Sur le plan intellectuel:

- Connaissances scientifiques abordées dans les cours de géographie, géologie, sciences de la terre etc.
- Rôle de la télévision, des programmes documentaires, mais aussi des dessins animés et films où grottes et gouffres peuvent faire figure de cadre principal.
- Connaissances acquises après la visite à travers les expériences concrètes venant modifier toute la fantasmagorie.

4. Recommandations

Face à cet enfant qui nous demande les yeux écarquillés: «Tu es sûre qu'on n'a pas besoin d'un masque à oxygène pour entrer dans la grotte?», ne riez pas, ne plaisantez pas, ne vous moquez pas. Répondez avec beaucoup de sérieux: «Non, mais par contre, ce qui est indispensable, c'est de porter un casque; il a deux fonctions: la protection et l'éclairage, etc...». «Et les dragons? et les monstres? et les insectes?» «Tu sais, il existe deux dangers seulement que tu cours dans une grotte: de perdre le groupe, c'est pour cela qu'il faut toujours rester avec le groupe, et de te faire mal. Donc, si tu suis toutes les mesures de sécurité que nous t'indiquons, tu n'as absolument aucun danger.» «Et t'est-il déjà arrivé de trouver un superbe trésor dans une de ces grottes??»

Souvenons-nous que nous-mêmes, spéléologues adultes et avertis, sommes animés par le même fantasme, le

même sentiment de fascination et d'enthousiasme lors de l'exploration d'une grotte. Bien sûr, c'est un autre «trésor» que nous recherchons: une continuation vers un réseau nouveau et encore inconnu, des concrétions rares et fragiles à prendre en photo, ou encore une nappe d'eau souterraine pouvant servir à l'usage de régions mal irriguées... Rappelons-nous notre euphorie et notre fascination quand nous découvrons la moindre trouvaille, le moindre indice sur l'histoire de cette grotte...

Et n'oublions pas que nos trésors valent tout aussi bien les leurs...

Il est vrai que leurs questions nous paraissent parfois drôles et saugrenues, mais ne laissons pas nos enfants perdre leur *capacité de rêver*; car comme nous, c'est elle qui les fait avancer.

5. Conclusion Générale

En dépit de nos occupations spéléologiques diverses, ce projet a su se faire une place conséquente au fil des années depuis qu'il a été lancé.

Les jeunes enfants que nous avons initiés à la spéléologie sont devenus une équipe qui ne pense qu'à avoir plus de contact avec le monde souterrain. Notre objectif de transmettre cette éthique de l'exploration souterraine aux générations futures afin qu'à leur tour elles prennent le relais et s'investissent dans un projet d'une plus grande ampleur, fidèle à la tradition de leurs aînés. Il se poursuit même avec l'élargissement de cette jeune équipe, à mesure que les enfants des spéléologues naissent et grandissent, allant même jusqu'à faire participer des enfants de deux ans à des sorties comme le Réveillon de Noël annuel célébré dans la grotte de Roueiss.

Notre désir le plus profond est que, en luttant contre les tabous et la dégradation de ce monde souterrain, de préserver l'objet de notre passion et de la faire partager aux autres.

Afin d'arriver à ce résultat nous gardons nos options ouvertes pour accueillir autant des idées nouvelles que des nouveaux participants.

LEARNING PACKAGE FOR TEACHERS ABOUT CAVES AND KARST

PIERRE-YVES JEANNIN, URS EICHENBERGER

Swiss Institute of Speleology and Karstology, SISKA, PO box 818, CH-2301 La Chaux-de-Fonds, Switzerland

Abstract

The Swiss Institute of Speleology and Karstology decided 5 years ago to promote public knowledge and broaden people's sensitivity to caves and karst. Beside courses and talks given on various occasions, the idea was to provide a "ready-to-use" pack of information for teachers.

Two suitcases have been realized for this purpose.

Suitcase 1 (documentation suitcase) encloses a CD-ROM with a ready-to-use PowerPoint presentation on caves and karst in two versions (for children up to 12 and for children above 12). All slides have been printed (B&W) and assembled in a folder, making it ready to photocopy. Another folder contains a user's manual for the teacher about the way to use the suitcases. Some brochures are also included in this package.

Suitcase 2 (experiments suitcase) encloses the material necessary for making six experiments with children. In fact the suitcase includes only the material which may be difficult to organize by the teacher and for each experiment a clear list of material to be organized by the teacher is provided (e.g. PET-bottle or sugar).

This suitcase has been developed for Switzerland because examples used in the explanations are mainly from this country. It is available in French and German. It is being discussed whether a version for France and another one for Germany should be made. The realization of an English version with adaptations for other Countries (e.g. US or UK) is open to discussion!

TRAINING, OUTREACH, AND EXPLORATION AT THE EAST MOUNTAIN PLATEAU, MENGZI COUNTY, YUNNAN PROVINCE CHINA

PATRICIA KAMBESIS and CHRIS GROVES

Hoffman Environmental Research Institute, Western Kentucky University, Bowling Green, Ky, USA

Abstract

With major support from the US Agency for International Development, since 2006 Western Kentucky University's China Environmental Health Project (CEHP) has worked with Chinese researchers and graduate students to help them to develop skills in order to address karst water access and water quality issues. In 2008, CEHP conducted a karst field methods workshop at Southwest University (SWU) in Beibei, China, followed by a nine-day field session which included hydrologic karst inventory, field mapping, and water/soil sampling on the East Mountain plateau in Mengzi County, Yunnan Province. The workshop covered topics that included basic hydrologic field work documentation, cave mapping and GPS methods, georeferencing of field data, transformation of field data into digital maps and GIS representations, and instruction in basic Single Rope Techniques with a strong emphasis on safety

A total of 14 graduate students and two faculty members participated in the SWU workshop. After orientation for all students, the workshop was run in split sections with 8 students in each section. The students switched sections so that all students received the same amount of instruction on each topic each day. Topics included field mapping techniques and methods, digital cartography, and GIS. Six instructors taught the SRT section, allowing for a nearly one-to-one student/instructor ratio that provided each student with focused instruction. Instructors were able to assure that each student clearly understood safety issues.

After the classroom training, students and faculty went to East Mountain Plateau in Yunnan Province, just north of the border with Vietnam, to practice the skills they learned. The joint Chinese-American team continued karst hydrologic field work that was started in 2007, collected water and soil samples at various springs and cave locations and conducted in-cave and field mapping. Instruction was also provided in logistics of expedition planning and fieldwork, field data processing, cartography and report writing.

The effort not only provided pertinent training, but was also productive. One hundred and fifty kilometers of ground was covered during the field reconnaissance resulting in the survey and documentation of 27 shafts and 30 caves that were incorporated into a GIS project database. The Southwest University team with support from the WKU team collected 46 water and soil samples that were analyzed for water quality. Detailed geologic and hydrologic field reports were collaboratively produced by the instructors and students and not only added to the skill set of the students but also provided valuable hydrogeologic information that can be used to deal with water management issues on the Eastern Mountain Plateau.

FLYING THE FLAG FOR KARST AND GEODIVERSITY IN NSW, AUSTRALIA

STEPHEN F. MEEHAN

Manager, Karst and Geodiversity Unit

NSW Department of Environment and Climate Change, Australia

The Karst and Geodiversity Unit (previously Karst Conservation Unit) of the New South Wales (NSW) Department of Environment and Climate Change was established in July 2006 and has the primary aim of *protecting, conserving, and promoting karst and geodiversity for the benefit of current and successor generations*. It is the first of its type within the NSW Government, and is responsible for over 40 publicly-managed karst environments.

The formation of the Unit represents a significant breakthrough for the many karst practitioners, researchers and speleologists whom have long supported such an initiative. It also demonstrates a growing awareness and recognition of geodiversity by the people of NSW, in particular, its role in supporting ecological systems and processes, which had often been viewed in isolation.

The Unit has a diverse range of operational and strategic responsibilities, including the review and preparation of geoconservation plans, policy formulation, the provision of technical advice, approving speleological activities (including cave exploration and diving) and assessing applications for karst-related research. Of particular relevance to the *Educating Citizens about Living in Karst Symposium*, the Unit is also responsible for raising awareness of karst and geodiversity issues within the NSW Government and community generally. To achieve its education objectives, the Unit, in collaboration with industry specialists, speleologists and the Karst Management Advisory Committee (a statutory committee created under the National Parks and Wildlife Act 1974), has developed a number of products which individually and/or collectively enhance community understanding and appreciation of karst and geodiversity values. These products include the *geoLOGIC Fact Sheet Series*, *Karst Research Prospectus* and *NSW Karst Environments* poster, all of which have received favourable community feedback.

A key challenge for the Unit and one acknowledged by the Department of Environment and Climate Change is the mainstreaming of karst and geodiversity into contemporary conservation dialogue. Consequently, the Unit has embarked on what is best described as a marketing campaign, taking the opportunity to promote karst and geodiversity at targeted forums, including the inaugural *DECC Karst Managers Forum* and more informal events such as presentations to stakeholders. This paper details the Unit's educational achievements since its inception in July 2006 and outlines future initiatives which may support geoconservation on public and private lands. It also provides the basis for on-going interactions between the speleological community, researchers, and other stakeholders in *flying the flag* for karst and geodiversity in NSW, Australia.

1. Introduction

Parks and reserves managed by the NSW Department of Environment and Climate Change (DECC) contain karst environments of state, national and international significance. In relative terms, these environments (and associated values) remain poorly understood, with past focus given to above or surface environments. Recent initiatives of the NSW Government, in particular the formation of the Karst and Geodiversity Unit (KGU) in July 2006 and Karst Management Advisory Committee in November

2006, are helping to redress past imbalances, while ensuring that karst and geodiversity issues are prominent in strategic and operational planning. More importantly perhaps, they are also helping to mainstream karst and geodiversity issues; such as the case with biodiversity, to ensure that future initiatives have the optimum chance of succeeding.

In adopting a contemporary approach to karst and geodiversity management, the NSW Government recognises that private-public partnerships are integral to the sustainable management of the State's natural resources.

These partnerships, whether formal or otherwise, provide opportunities for government agencies to influence resource management decisions made off-park, while being fiscally prudent in times of dwindling economic resources. From a public or community perspective the aforementioned holds equally true; landholders who have previously relied on their own resources have the opportunity to draw on the expertise and resources provided by government, meaning that proposed initiatives such as the fencing-off of sensitive areas or the identification and recording of significant geological/geomorphological features have a better chance of being realised.

The DECC (through the KGU) has identified geoeducation as a key element towards fostering and maintaining public-private partnerships. Initiatives such as geo-specific forums, seminars and fact sheets are helping to raise awareness of geoconservation issues and provide avenues for private landholders to utilise the resources and expertise of government agencies. Geoeducation initiatives can also assist managers, planners and other relevant officers to establish connections with stakeholders that may otherwise be absent, while at a deeper, more intrinsic level, provide the basis for long-lasting, mutually beneficial relationships, which are critical to the realisation of geo-conservation outcomes.

2. Context

Limestone deposits form a broad, irregular fringe around the Australian Continent and comprise approximately 4% of the total land surface. Although below the world average for outcropping carbonate stone, Australia is well represented by a variety of karst features and environments, ranging from expansive soft outcrops, in the order of 2 million years old, to ancient, *hard rock karst* more than 300 million years old. Whilst not the largest or deepest in the world, Australia's karst environments are of immeasurable value; its relative geological stability, combined with a wide array of past climactic conditions, has resulted in the formation of the world's most complex and truly ancient karst systems (Gillieson and Spate 1998), and contain the most diverse subterranean fauna yet recorded (Wong et al., 2001).

The majority of New South Wales (NSW) karst environments occur in older, hard rock areas where limestone is recessive in the landscape. These *impounded karsts* are found in over one hundred separate locations, ranging from Ashford, in the State's far north, to Delegate in the far south. NSW karst environments are of outstanding national and international importance, and recognised by the United Nations Educational Scientific and Cultural

Organisation (UNESCO) as having the most complex process of cave evolution and development yet demonstrated (Wong et al., 2001). They are also the most studied in Australia due to their plentiful array of endemic flora and fauna, intricate origins, rich cultural history and accessibility (Gillieson and Spate 1998), and are visited by over 500,000 people each year.

NSW karst environments which are managed by the DECC contain over 40 individual karst environments. These contain four of the five *subterranean biodiversity hot spots*, as described by Thurgate et al., (2001), over 1000 identified (or tagged) caves and the oldest open cave system in the world, the *Jenolan Cave System* (Osborne et al 2006). Originally recognised for their outstanding aesthetic and recreational values, DECC karst environments are amongst the oldest protected areas in the world. The Wombeyan Caves were reserved from sale for the purposes of leisure and cave preservation in 1865, followed by the Jenolan Caves in 1866; both preceding the declaration of the world's first national park (i.e. Yellowstone National Park) in 1872.

The DECC manages approximately one third of NSW cavernous karst environments, with the remainder on private land. A percentage of DECC karst environments are contiguous with similar areas off-park. These areas are of potential conservation value and would benefit from further evaluation and protection.

3. Geo-education Initiatives

The following geoeducation initiatives have been undertaken by the DECC since July 2006:

3.1 DECC karst managers forum

In March 2007, a *karst manager's forum* was held at the Jenolan Karst Conservation Reserve. This was the first of its type convened by the DECC and was attended by more than 40 people from across NSW. Consistent with DECC's geoeducation objectives, the Forum had the following specific aims:

- To confirm key issues with respect to karst and geodiversity management;
- To identify and gain consensus on strategies to address key issues;
- To establish a DEC Cave and Karst Managers Network;
- To foster increased understanding, appreciation and awareness of karst and geodiversity values; and
- To confirm key stakeholders, and promote the role of the KGU in policy development and the

provision of technical advice.

3.2 Geologic fact sheets

The DECC has produced a variety of info-brochures, fact sheets and other educational material relating to biodiversity. Geodiversity however, has not received the same focus as geo-education initiatives, generally limited to site-based, interpretation programs and ad hoc references in broader park education material. To address past shortfalls, the KGU, in conjunction with local graphic designers, the DECC Publishing Section and Dr Armstrong Osborne from the University of Sydney, has produced a series of fact sheets under the following themes:

- Geodiversity: the foundation for life;
- NSW karst environments: the treasure tests of time;
- Karst forming and development processes;
- Karst environments: more than just caves and pretty rocks;
- Karst: people, places and history;
- Living on karst.

The *geoLOGIC* Fact Sheet Series provides better-than-basic information on karst and geodiversity and is aimed at secondary school students (and above), landholders and members of the DECC staff.

3.3 Karst resources database

Researchers (including speleologists) have provided much of DECC's available information on karst and geodiversity; particularly as it relates to cave numbers, location, morphology, structure and significance. Past and current members of the DECC staff have also contributed to the existing information base, by documenting key features and attributes of caves during the course of park inspections.

Until recently, a significant percentage of the above-mentioned information was only available in hardcopy and stored in files located in regional/area offices, or the DECC Library. This provided minimal opportunities for resource sharing and increased the potential for valuable information to be lost/damaged; it also meant that geoeducation initiatives such as the production of maps, posters, fact sheets etc., may be compromised due to valuable information being unavailable or in the wrong format. A Karst Resources Database has been subsequently developed which includes information on:

- number and location of karst environments;

- cave biota and ecosystems;
- Indigenous and historic cultural heritage;
- threatened flora and fauna species;
- surface and groundwater hydrology;
- palaeoecology;
- archaeological records; and
- geodiversity and geoheritage.

3.4 Karst research prospectus

The framework for conducting research in DECC parks and reserves is provided by the Science Investment and Management Plan (SIMP) 2006 and the Parks and Wildlife Group Strategic Plan. These documents acknowledge research as an effective means by which the DECC can meet its objective of protecting the state's natural and cultural heritage.

The DECC supports and/or conducts research which raises community and staff awareness of geodiversity issues and which assists its objective of protecting the state's natural and cultural heritage. Consequently, a karst research prospectus has been developed to:

γThe Karst Research Prospectus was developed in consultation with the DECC Publishing Section, the DECC Strategic Science Unit and the Karst Management Advisory Committee.

3.5 Karst environments NSW poster

To promote karst and geodiversity values both within and external to the DECC, the KGU, in conjunction with the DECC Publishing Section and local graphic designers, is producing a series of theme-related educational posters. The first of these (i.e. *Karst Environment: New South Wales*) has been produced, with information included under the following headings:

- Ancient Landscapes and Ecosystems;
- Nature's Time Capsule;
- Fragile and Vulnerable;
- National and International Importance;
- Hidden Caves and Mysterious Life; and
- Where to Experience Karst Environments.

In accordance with the Unit's geoeducation objectives, posters will also be developed under the themes of *NSW Geodiversity*, *Living on Karst* and *NSW Karst Environments: Past and Current Associations*.

4. Conclusion

The geoeducation initiatives identified in this paper are

assisting the NSW Government in meeting its conservation objectives and provide the basis for on-going and positive communications with stakeholders. By establishing the KGU and Karst Management Advisory Committee, the NSW Government has also ensured that these and other objectives have the optimum chance of being met, with both entities having the opportunity to champion geodiversity and related issues at a variety of DECC and community forums. While the use of geoeducation as a management tool has yet to be assessed, fiscal realities, and an ever-tightening resource base, indicate that public and private landholders will be under increasing pressure to manage the resources under their custodianship. Geoeducation has the potential for reducing this pressure by instilling a better appreciation of karst and geodiversity values within the community. Similarly, it may ensure that landholders are better informed and/or equipped, enabling a more strategic and cost-effective approach to resource management.

References

- Gillieson, D. and Spate, A. (1998) Karst and Caves in Australia and New Guinea. In *Global Karst Correlation*. Science Press: Beijing.
- Thurgate, M. E., Gough, S., Spate, A and Eberhard, S. (2001) Subterranean Biodiversity in NSW: From Rags to Riches. In *Humphreys, W. F. and Harvey, M. (eds) Subterranean Biology in Australia*.
- Wong, T. Hamilton-Smith, E. Chape, S. and Friederich, H. (eds) (2001), *Proceedings of the Asia Pacific Forum on Karst Ecosystems and World Heritage. 26-30 may 2001*.

LIDAR 3D PHOTO REAL MODELING OF DEVILS SINKHOLE IN ROCKSPRINGS, TEXAS

BOBBIE NEUBERT¹, J. A. BELLIAN², XUEMING XU¹, KEVIN MCGOWAN³, GEARY M. SCHINDEL⁴, E. CALVIN ALEXANDER, JR.⁵

¹*Real Earth Models, 4100 McEwen Rd., Suite 240, Dallas, TX, 75244-5184 USA, BobbieN@realearthmodels.com, XuemingX@realearthmodels.com*

²*Bureau of Economic Geology, Jackson School of Geosciences, University of Texas, Austin, TX USA, Jerome. bellian@beg.utexas.edu*

³*Kevin McGowen Photography, Houston, TX USA, Kevin@kevinmcgowan.com*

⁴*Edwards Aquifer Authority, 1615 N St. Marys, San Antonio, TX 78215 USA, gschindel@edwardsaquifer.org*

⁵*Geology and Geophysics Department, University of Minnesota, Minneapolis, MN 55455 USA; alexa001@umn.edu*

Abstract

Devils Sinkhole, located northeast of Rocksprings in Edwards County, Texas, was first visited by European settlers in 1867 and is a registered National Landmark and a Texas Parks and Wildlife Department - State Natural Area. The Sinkhole provides a natural exposure of approximately 100 m stratigraphic section of the lower Cretaceous, Edwards Group Limestone. The entire depth of Devils Sinkhole is 107 m deep making it the third deepest cave in Texas and is one of the few caves in the Edwards Plateau that penetrates to the water table. Two freshwater lakes are located along the perimeter of the breakdown mountain formed by the entrance collapse are home to two unique crustacean species – an endemic amphipod and a rare aquatic isopod. The walls of the cave support a Mexican fern species found in few other locations in the United States. The walls of the cave are also the summer home to an estimated three million Mexican free-tailed bats whose nightly departures to forage for insects is a significant tourist attraction.

The use of LiDAR (Light Detection and Ranging) instruments to map Devils Sinkhole was initiated in 2005 with volunteer help of cavers from the Texas Cave Management Association and staff members of the Texas Parks and Wildlife Department and Texas Bureau of Economic Geology. This multifaceted project supports a major public outreach program for the Devils Sinkhole State Natural Area. Access to the pit is limited because of the 42-meter deep vertical drop. The 3D, LiDAR model will allow visitors to experience a virtual, bat's-eye view tour inside the Sinkhole. The project also offers quantitative data for geological and biological studies of karst terrains.

In 2007, Real Earth Models introduced to the Devils Sinkhole project, a unique process for draping digital photography onto the LiDAR point cloud surface to produce a 3D Photo Real Model. This process integrates high-resolution LiDAR data and digital photographs to accurately match the actual geology exposed within the Sinkhole. The resultant 3-D Photo Real Model combines the resolution of digital photos (mm scale) with the positional accuracy of cm-scale LiDAR. This model is a life-like, replica of Devils Sinkhole that can be rotated and viewed from any perspective. The model also allows a precise, quantitative measurement of physical properties, texture and surface features in natural color.

THE DEVILS SINKHOLE LIDAR PROJECT, EDWARDS COUNTY, TEXAS USA

GEARY SCHINDEL¹, ALLAN B. COBB², TRAVIS SCOTT³, RANDY ROSALES⁴

¹ *Edwards Aquifer Authority, 1615 N. St. Mary's Street, San Antonio, TX 78215 USA; gschindel@edwardsaquifer.org*

² *Texas Cave Management Association, 4019 Ramsgate St., San Antonio, Texas 78230 USA; ; ac@oztotl.com*

³ *Texas Cave Management Association, 6206 Stratford Circle, Bryan, Texas 77802 USA; Travis@oztotl.com*

⁴ *Texas Parks and Wildlife Department, Del Rio, Texas USA ;randy.rosales@tpwd.state.tx.us*

Abstract

The Devils Sinkhole LIDAR Project was a coordinated effort to create a digital representation of the Devils Sinkhole for use as an educational and scientific tool. The Devils Sinkhole is a large vertical shaft and room located in Edwards County, Texas USA. The cave and property are owned and managed by the Texas Parks and Wildlife Department (TPWD). The Devils Sinkhole is a 45-m deep vertical shaft to the top of a large breakdown mound. The main cave room is approximately 100 m by 150 m and approximately 50 m high. Total depth of the cave is approximately 100 m. The cave was formed by collapse into underlying water filled passage but attempts to enter air filled and water filled passages off of the main collapse chamber have been unsuccessful. Some small rooms are formed within the breakdown mound and along the edges of the room.

With an estimated three million bats, the Devils Sinkhole is one of the best locations in the United States for the public to view a large bat flight during the summer months. Visitors view of the entrance shaft from a viewing platform; however, the public cannot enter the cave because of safety considerations. Therefore, it is difficult to convey the size, shape, or formation of the cave. The LIDAR project was envisioned to create a digital three-dimensional representation of the cave for use primarily at the Devils Sinkhole Visitors Center and at other educational institutions. The LIDAR process allowed the extremely accurate digital mapping of the cave with the draping of digital color photographs to create a photo-real map of the cave. The end product is an interactive model of the cave for use as in public education and scientific study. This project was a partnership between the Texas Cave Management Association; Texas Parks and Wildlife Department; Texas Bureau of Economic Geology; Real Earth Models, LLP; and Kevin McGowan Photography. The project budget was approximately \$12,000, which was supported by donations from twelve sponsors, and the donation of thousands of hours from more than one hundred volunteer cavers over a two-year period.

This paper will discuss the organization and coordination of running a complex mapping projects using state of the art laser mapping equipment, digital photography, and entry and egress of volunteers and equipment in the bottom of a 45-meter pit and active bat cave. Work was performed under the direction of a health and safety plan and site safety officers. Fieldwork was performed during five weekend-long sessions with a range of 5 to 40 cavers present during the work.

IDEC: AN IMAGERY DATA EXTRACTION COLLABORATIVE AND EDUCATION TOOL FOR CAVE AND KARST

JESSICA R. SNIDER¹, DIANA E. NORTHUP¹, JOHANN VAN REENEN², M. ALEX BAKER², CHRISTY CROWLEY², BRIAN FREELS-STENDEL², JENNIFER J. M. HATHWAY¹, LINN MARKS COLLINS³, MARK L.B. MARTINEZ³, JAMES E. POWELL³

¹*Department of Biology, MSC03 2020, University of New Mexico, Albuquerque, NM 87131*

²*University Libraries, MSC05 3020, University of New Mexico, Albuquerque, NM 87131*

³*Escience Department, Los Alamos National Laboratory Library, Los Alamos, NM 87545*

Scientific fields of study such as microbiology, astrobiology, and cave and karst sciences contain large collections of images and their associated biological, physiochemical and geological datasets. The vast majority of these images are never shared nor examined by more than a handful of scientists. As interdisciplinary studies grow more common, being able to have scientists, students, teachers and interested citizens collectively examine, analyze and annotate these images and data will grow in importance. In order to allow access to images and associated data, our group has created IDEC: Imagery Data Extraction Collaborative (<http://idec.aisti.org>). IDEC consists of an integration of three open-source tools: Drupal, Gallery and UNM DSpace. Drupal is an open-source content management system that has been rated best-in-class by the IBM Internet Technologies group. Gallery is an open-source image management system that can be integrated directly into Drupal. UNM DSpace is an open-source digital object repository platform (https://repository.unm.edu/UNM_DSpace/handle/1928/526 at the Univ. of New Mexico) that houses the repository of available scanning electron microscopy images. A commenting function has been implemented in UNM DSpace to allow viewers to provide their insights from viewing the images. All three tools are relatively easy to install and configure, and are widely used globally. We are using this configuration as a base for developing our broader collaborative workspaces for knowledge discovery with weblogs, forums, feeds, and image functionality enabled. Registered users of IDEC can scroll through photo albums of SEM images designed around a central theme or question and can add their own conclusions or insights for each image. Users can participate in forums or blogs discussing topics such as current trends and questions in that area of science, interesting discoveries and debates about interpretations of the data. Lessons and background information covering microbiology, microscopy and cave sciences have been created to teach high school and college level students using select image galleries. Finally, any recent relevant scientific articles, newspaper articles and government reports are displayed in the Feed Aggregator as well as links to other portal Web sites, allowing users to get the latest information on microscopy, geology, microbiology, astrobiology, speleology and geomicrobiology. We believe that this type of easy to use, virtual, collaborative research e-workspace will help answer questions with important implications in our subterranean world of caves that are a key feature of karst terrains and for the detection of life on other planets (astrobiology). Our initial albums focus on the geomicrobiology of caves and karst.

1. Introduction

Microscopy [Scanning electron microscopy (SEM), e.g.] images provide large amounts of biological and geological data for cave and karst scientists, microbiologists and astrobiologists. However, many times, only the scientific team obtaining and analyzing the data are able to view or use data contained in these SEM images. If substantial discoveries are made, only one or two of the images may be published for the scientific community to see. As time goes on, studies are terminated or just slowly forgotten, scientists move or retire and the SEM images and the data

they collected can slowly disappear. A similar and equally disappointing neglected facet of this technology is that the SEM images and the data they contain are rarely shared among scientists in different locations. Since the images are not shared and the scientists are not able to meet and discuss common results, possible discoveries of features that occur in caves around the world would be missed. In either case, data are lost. To prevent this loss, the National Science Foundation suggests the use of a virtual collaborative research center, which they defined as "a center without walls in which the nation's researchers can perform their

research without regard to geographical location” (Lederber and Uncaphar 1989).

As scientists working with SEM images of geomicrobial interactions, our team has experienced both of the above mentioned problems. This led us to identify the following goals:

- (1.) To prevent the lost of data due to insufficient communications and archiving of data from multiple studies.
- (2.) To create an online digital repository that can provide a way to both store and share SEM image data, thus increasing the collaboration abilities of scientists over the US and the world.
- (3.) To allow this online digital repository to be used by schools, the public and colleges as a way of increasing scientific learning, outreach and interest.

An online collaborative workspace facilitating the timely analysis and annotation of image databases related to caves and

karst will address these goals and will supplement the efforts of the Karst Information Portal (KIP, <http://www.lib.usf.edu/KIP/>) (Hose et al, 2005) to promote better communication within the karst community.

2. Conception and Goals of UNM DSpace and IDEC

Our team believes that an online collaborative workspace that facilitates the timely analysis and annotation of cave related SEM datasets, such as SEM images and knowledge discovery among diverse individuals is needed. Starting in 2004, researchers, librarians and information technicians from the University of New Mexico and Los Alamos National Laboratory Library have been setting up both IDEC: Imagery Data Extraction Collaborative (idec.aisti.org) and a karst studies UNM DSpace (https://repository.unm.edu/UNM_DSpace/handle/1928/526 at the Univ. of New Mexico). UNM DSpace uses the social-technical model DSpace, which is an open-source digital object institutional repository developed by MIT and Hewlett-Packard (<http://www.dspace.org>). IDEC is a project of the Alliance for Information Science and Technology Innovation (AISTI: <http://www.aisti.org>) and uses the open-source content management system Drupal (<http://drupal.org>) and the image management software, Gallery (<http://gallery.menalto.com/>). We will use IDEC and

UNM DSpace to address the goals listed above, which we explain in detail below.

(Goal 1.) To prevent the lost of data due to insufficient communications and archiving of data from multiple studies.

Researchers will be able to upload the images and suitable metadata in both his/her institutional repository and UNM DSpace repository. Users may also upload additional files (audio, video or text) that provide information related to the images. The images will be automatically assigned a unique identifier in the repository and a low resolution version of the scanning electron micrograph will be published in an RSS feed (Hammound et al. 2004). The researcher will also be asked to define keywords and other metadata related to image. Using this information, other researchers can search through the images of the UNM DSpace repository. Additionally, using a procedure called social tagging, other users will be able to view and add their own keywords and comments to images within the repository, increasing the possibility of finding similar features in images from different labs and locations. Currently, UNM DSpace has approximately 500 images with their associated metadata, including keywords. Thirty-three thumbnail images and definitions of various morphotypes found in the collection are also included on the Web site. *Morphotype* is the term our group uses to describe the best example of an observed, and generally re-occurring, morphology, such as a set of structures observed in an SEM arranged in a string against a background. These morphotypes serve as reference points for participating researchers as our common understanding grows and provides a common language for describing new morphologies.

Images of surface and cave ferromanganese deposits, pool precipitate deposits and microorganisms associated with lava tubes are included or being prepared for submission to UNM DSpace. Figure 1 shows the opening page of UNM DSpace.

To better design our repository and collaborative workspace, we created the following scenario that guides our current and future efforts:

Question: Are ferromanganese deposits of different colors occurring in different geological/geochemical settings and do the biological morphologies that occur with each color vary across colors?

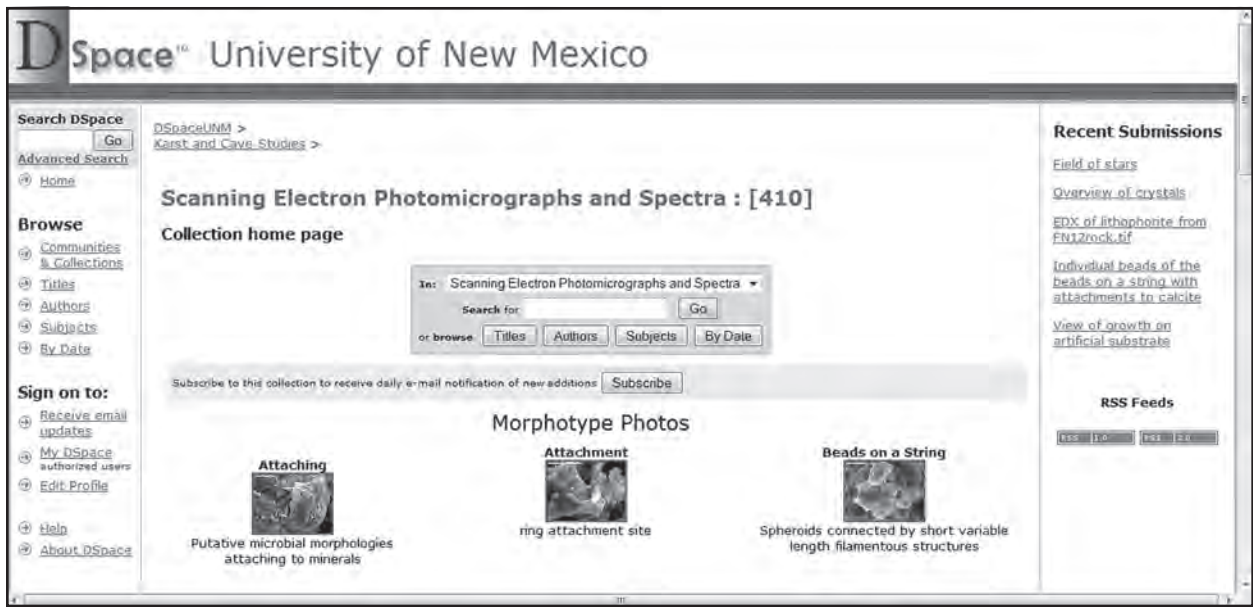

Figure 1: Opening page for the UNM DSpace. We have included three examples of the 33 thumbnail images and definitions of various morphotypes found in the images at the bottom the page. From this page, users can search through images using keywords, titles, or sample source or can begin to just scroll through all the images of the database.

To pursue these questions a scientist would want to:

- Pull up a Compass map of a cave with lots of ferromanganese deposits (FMD), such as Lechuguilla Cave, and see a plot of where FMDs occur and have been sampled.
- Call up images of biological morphologies that have been sampled from these FMDs. Obtain data on the color of these FMDs from which the biological forms came.
- Query what chemistry is known about these FMDs and their substrate.
- Be able to see a map of where reef and the backreef (geological setting) occur in the cave vis-a-vis the FMD deposits.
- See associated macroscopic images of the deposits in color.
- Find information about the mineralogical setting in which the FMDs occurred.
- Create a dataset of biological morphologies found in FMDs and associated mineralogical setting data and run analyses or statistical tests on the data.

(Goal 2.) To create an online digital collaborative workspace that can provide a way to both store and share SEM image data, thus increasing the collaboration abilities of scientists across the US and around the world.

To create a grouping of images, researchers can create an “album” of these in IDEC that they would like to examine more closely and analyze them via an online dialogue. Researchers can include titles, questions and captions with each of the images in the album. From here, fellow researchers, students or any other registered user can view the album, add comments or questions to each image or even begin an online forum to debate a feature or point they find significant in the image.

At the IDEC entry page, shown in Figure 2, users will need to register with a username and password of their choosing. Registered users can click on the Image Gallery, which is shown in Figure 3. Within the Image Gallery the user can open and view various albums created around a central theme or questions. By clicking on the thumbnail from a particular album, users can then scroll through the images in a larger format and make comments about the image. All comments are shown with the image and comments can be made on previous comments. Users can participate in Blog Posts or Forums and view all comments of an ongoing e-debate regarding a stated question. The Feed Aggregator displays all recent news and some scientific articles about caves, karst and microbiology. Finally, since the IDEC Web



Figure 2: Opening page to the IDEC e-learning center. A welcome message introduces the project, explains how to log on and outlines the different features of the Web site.

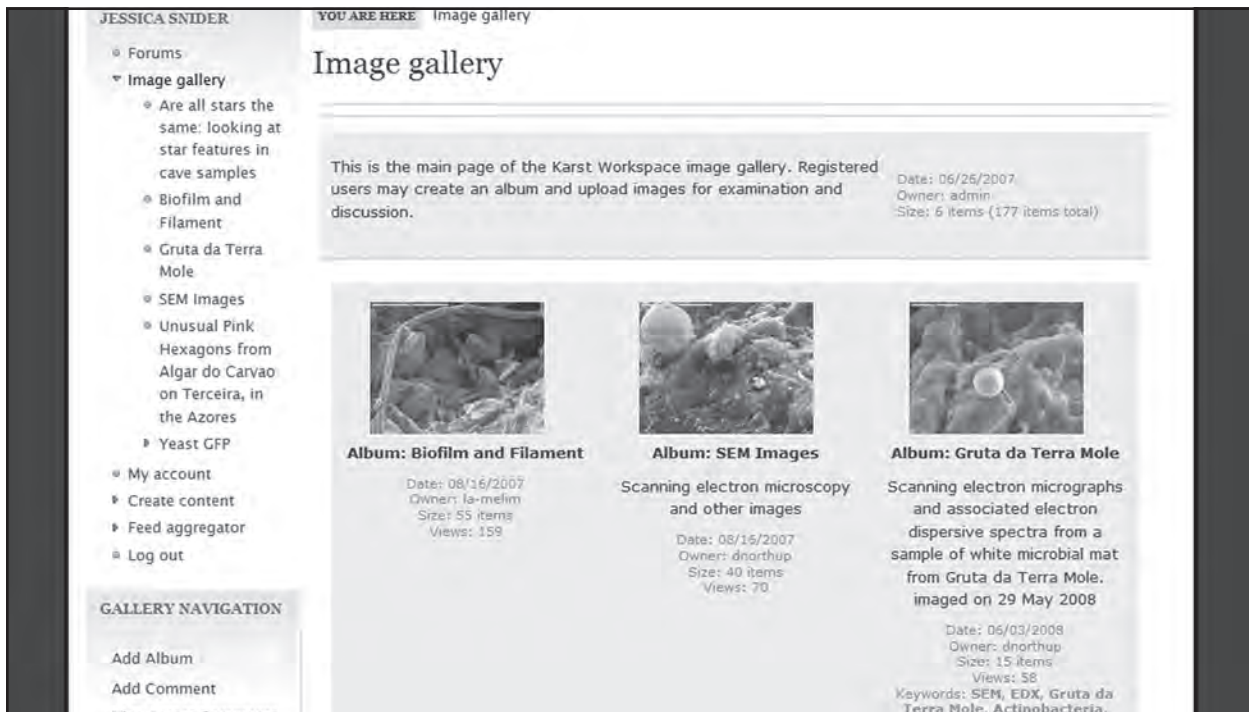

Figure 3: Image gallery page of the IDEC Web site. From here, users can click on the thumbnails to view the images in the album in a larger format. Title, date created, owner and number of images of each album are displayed below the thumbnail.

site is a part of the KIP, links are included to papers and current news from the KIP portal.

In order to better explain the uses of the IDEC Web site, we have created the following scenario.

Question: Are the reticulated filaments (a.k.a. cholla) found just in pool precipitates, or are they found in other deposits? Are all the reticulated filaments the same, or are there variations? Have other groups found these morphologies, or anything that looks similar? Does anyone have any idea what these reticulated filaments are?

To pursue these questions a scientist would want to:

- Consult the morphotypes to look for a likely “type” specimen.
- Pull up a variety of images with this morphology and various metadata associated with the image.
- Create a new image album and title the image album with the question he/she wants to ask about the images.
- Post the images as an album and include appropriate metadata in the image captions.
- Display the album on the IDEC site. The scientist may also choose to send an email to several of their colleagues requesting their input.
- Over time, comments will be added as different scientists view the album. Other groups who have albums of images with common features can post these for comparison. Hopefully, this will lead to future collaborations, experiments, and discoveries.

(Goal 3.) To allow this online digital repository to be used by schools, the public and colleges to increase scientific thinking and learning, outreach and interest.

Included on the IDEC Web site are numerous features, such as lessons linked to specific image albums and news stories covering cave and karst science (from the KIP Web site), which can be used in schools and college classrooms and will be of interest to the general caving community and public. Lessons are designed to be multidisciplinary and inquiry-based. While most are designed to be used in a college classroom, some were created for use in middle and high school classes. A lesson plan and worksheet are included for each module. One lesson introduces the concept of biological definitions and requires students to develop definitions for “biofilm” and “biofilament” using SEM images of these features. Another requires that students learn to measure star-like morphologies in

SEM images and determine if location or composition of the star features affects its size. In addition to the lessons, several sections of the IDEC Web site could be interesting for the caving community and general public. The Feed Aggregator and the link to KIP provide both news and scientific papers covering issues related to caves, karst and microbiology. Reports from the general public asked to view and comment on SEM images shows that most people have enjoyed the experience and found the SEM image “pretty” and “cool.” (Jeff Snider, personal communication). Many were also excited that they were contributing to active science studies and noticed details in the images that the scientists did not notice. Additionally, this allows for a truly multidisciplinary approach to studying the SEM images, since the images displayed on the IDEC Web site will be viewed by people with numerous different backgrounds and occupations.

In order to better explain the uses of the IDEC Web site, we have created the following scenario.

Teacher to students: What is a biological feature? How can scientists tell which are bacterial cells and which are just round looking bits of rock?

To pursue these questions a teacher would want to:

- Download the lesson plan and worksheets from the IDEC lessons Web site.
- Present the sample Powerpoint and background information included in the lesson plans.
- Provide students with the worksheet.
- Using classroom computers students study the images. After going through the images once without any additional metadata, students begin to go through the images again, but this time with EDS scans and additional information.
- Students will be asked to list which morphologies they believe are biological features and which are geological features.
- As students go through the images, they begin to realize that the EDS scans show the amount of carbon in a select feature in the image in comparison to that of the background material. Features in the image that have a carbon peak higher than that of the background on which the features rests are most like living (carbon based) cells.

3. Conclusion

Our team believes the UNM DSpace repository and IDEC

collaborative workspace are able to address the goals of image storage and data mining, collaborative research on a set of selected images, and public outreach in caves, microbiology and microscopy, and it is an integral part of the Karst Information Portal (KIP). UNM DSpace provides a digital location to both store and study images using the actual image, associated metadata and unique and advanced forms of search engines. We feel that these sites will promote multi- and interdisciplinary connections that lead to knowledge discover. This is especially important for geomicrobiologists and astrobiologists, two disciplines that rely heavily on imagery with corresponding chemical and physical data, allowing them to “meet” electronically and discuss features found in images from multiple sources.

IDEC creates a digital environment in which researchers can collaboratively explore images at different scales for new knowledge and pull in other data to make conclusions. IDEC and UNM DSpace can, in doing this, begin to break down the barriers among various disciplines and scientists of different generations. Finally IDEC, when used in high school classes, should increase interest in scientific discovery due to being involved in active discovery methodologies, with advanced techniques (e.g microscopy), and in unusual settings (karst-based caves). As more users join and add their own images and data, additional uses and goals will be developed for the project. We believe this is still in the proof-of-concept phase. Long term we hope to employ automated image data extraction technologies to assist in discovery across ever growing date sets and to develop more seamless electronic scientific collaboration tools and “virtual work benches.” We continue exploring ways to increase collaborative effort among researchers. Participating in

IDEC is often an additional activity for them and, as others have found (e.g. Seddon, Skinner, and Postlethwaite, 2008) sustained engagement in online communities is a challenge that require ever more elegant technological enabling.

Acknowledgement

We would like to thank AISTI for both funding and host of the IDEC Web site.

References

- Hose, L.D., Brinkmann, R. and D.E. Northup (2006) The Global Karst Digital Portal: An Emerging Collaboration Will Enhance Information Exchange. Proceedings of the 17th National Cave and Karst Management Symposium, New York, p.127–131.
- Lederberg, J. and Uncaphar, K. (1989) Towards a National Collaboratory: Report of an Invitational Workshop at the Rockefeller University New York. National Science Foundation, Arlington.
- Hammond, T., Hanney, T., and B. Lund (2004) The Role of the RSS in Science Publishing: Syndication and Annotation on the Web. D-Lib Magazine **10(12)**, <http://www.dlib.org/dlib/december04/hammond/12hammond.html>.
- Seddon, Kathy; Skinner, Nigel C.; Postlethwaite, Keith C. (2008) Creating a model to examine motivation for sustained engagement in online communities. *Education & Information Technologies*, Vol. 13 Issue 1, p17–34.

THE PROJECT UNDERGROUND EDUCATION PROGRAM

CAROL ZOKAITES

*National Coordinator of Project Underground, Inc.
2281 Lubna Dr., Christiansburg, VA 24073*

Project Underground is a national educational training program that promotes public involvement and increases public awareness about karst areas and the land use issues unique to these areas. Developed in Virginia, Project Underground explains how to teach about karst resources in the classroom.

The Richmond Area Speleological Society (RASS) initially developed Project Underground in 1993 in response to a lack of training materials for educators concerning cave and karst resources. RASS worked together with several groups and individuals to produce the Project Underground Natural Resource Education Guide, a curriculum guide on karst resources.

The challenge was how to develop an environmental education program using the Project Underground guide. A National Coordinator was hired to create and direct the Project Underground program. A workshop format for the program was established, using a “train the trainer” model to establish a workshop leader network. The Project Underground materials are available through these workshops where educators are shown how to teach karst science in classroom situations. This provides a level of quality control not present in many environmental education programs.

Though the Project Underground Education Guide was initially designed for K-12 education, it quickly became apparent that its usefulness extended to other adults as well. Activities such as “Lost River Village” help land planners, government personnel and local citizens understand the risks of improper land use on karst and the importance of careful land planning in these karst areas.

Today the Project Underground program has disseminated over 5,000 education guides to educators and citizens across the United States. The program has become a leader in cave and karst education for U.S. citizens at many levels. Karst education has also become an important step in karst resource conservation and protection.

1. Introduction

The vision of Project Underground, Inc. is “People will make wise, informed, choices as they manage cave, karst and groundwater resources to protect the underground ecosystems for the health of current and future generations.” To accomplish this vision Project Underground has a mission to “build the necessary awareness and responsible attitudes towards cave, karst and groundwater resources and their management needs among the general public through educational and interpretive programs. This will be accomplished by developing focused educational materials that address the importance and fragility of the karst environment, disseminating these materials, educating teachers and educators on the use of such materials and encouraging their wide spread use.”

Project Underground is a national environmental education program aimed at training teachers to teach cave and karst

science in the classroom. Traditional classroom teachers as well as outreach educators attend training workshops to learn about karst issues and receive Project Underground materials. The program promotes public involvement and increases public awareness about karst areas and the land use issues unique to these karst areas. Project Underground, Inc. is a non-profit organization governed by a Board of Directors and works closely with other leading national cave and karst organizations.

2. Education Guide

The Richmond Area Speleological Society (RASS) started Project Underground in 1993 in response to a lack of training materials for educators concerning cave and karst resources. RASS worked together with several groups and individuals to produce the Project Underground Natural Resource Education Guide (Barns, 1996). It was designed by educators and experts in the various disciplines of

Activity	Objective
Lost River Village	Illustrates potential impact to karst of land development, teaching participants the importance of careful planning
Sinkhole in a Cup	Shows students how sinkholes are formed via collapse of voids.
Hungry Cave Critters	Demonstrates that cave animals compete for limited food resources. Explains the concept of food generalist vs. food specialist and the food web.
Hello, Who's There?	Demonstrates that caves provide suitable habitats for wildlife species.
Belly-Crawl Mapping	Recognize and apply simple map-making and map-reading skills.

Table 1: Examples of Project Underground exercises and some learning objectives they meet

speleology. A writing workshop brought together cavers and environmental educators to develop activities to teach about cave and karst resources. These activities were field tested by educators and revised to best meet the needs of teachers. The activities are interdisciplinary and level-correlated.

The guide is divided into subject areas with background information provided on each lesson. The subject areas are Cave Critters, Rocks and Water, and Use of Caves. The Cave Critters section explains about the different animals found in a cave and describes the special environments these cave dwelling animals inhabit. Activities in this section have names like "Bat Echoes" and "Troglo ... What?" The Rocks and Water section explains the Geology and Hydrology of caves and how these interact in karst areas. Activities in this section have names like "Mysterious Waters" and "Lost River Village." The Use of Caves section describes some of the historical uses of caves to man and animals. It also talks about the study and exploration of caves. Activities in this section have names like "Ancient Cave Art" and "Belly-Crawl Mapping." (Table 1)

To encourage incorporation into lesson plans, each activity includes information on the objectives, subject, skill level, group size, time required, and key vocabulary words. The Project Underground activities are hands on and lead to participant discovery of the objectives. The hands on activities mesh well with the inquiry teaching methods used in most science classrooms (Zokaites, 2007). These lessons and activities are both interdisciplinary

and adaptable, covering many subject areas and all grade levels. The activities in the curriculum guide address many of the national science education standards. With the growing popularity of the Project Underground program the second and third editions of the Project Underground Natural Resource Education Guide have been printed with additional lessons and recommendations from teachers (Zokaites, 2006).

3. Workshops

The challenge was how to develop an environmental education program using the Project Underground education guide. In 1996, a non-profit corporation was established for Project Underground and a board of directors was elected. A national coordinator was hired to create and direct the Project Underground program. A workshop format was established for the program using a "train the trainer" model to create a facilitator, or workshop leader network. Project Underground materials are only distributed through these workshops. This provides a level of quality control not present with many environmental education curricula.

The Project Underground materials, including the guide, are available through workshops where educators are shown how to teach karst science in classroom situations. Facilitators first provide workshop participants with a primer on cave and karst science, using background discussions and slide presentations to explain about karst resources and why they are important. The participants

learn about the development of karst topography and the impacts of human activity on the water resources in karst areas, discuss public policy decisions relating to the unique karst environment and learn about the biodiversity in karst systems.

Facilitators not only provide educational materials, but also instruction on the use of these materials in the classroom. The activities in the lessons are practiced during the workshops so teachers are familiar with the materials and outcomes. Doing the activities helps the teachers become more comfortable with leading these activities for their students and outreach groups. Teachers are given time to create classroom unit plans using the Project Underground materials. Practicing the activities and creating unit plans in the workshops also increases the probability of the information being used by the participants in their classrooms.

Field experiences may be incorporated into the Project Underground workshops. Facilitators coordinate with karst scientists to provide field trips to sinkholes, sinking streams, and springs. Many participants have never seen these features in the field, or if they have, did not realize their significance. Use of these field experiences greatly enhance the workshops, helping to increase the likelihood of the materials and activities being used in classrooms and at educational events.

One component of the Project Underground guide that makes it attractive to classroom teachers is its compatibility with state and national science education standards. In Virginia, charts have been developed that correlate specific Project Underground activities with the Virginia Standards of Learning. This is critical because these Standards of Learning drive what goes on in the classroom. Project Underground staff works with many state and local education departments to incorporate the karst education materials into school programs. This allows teachers to earn Professional Development credits for attending Project Underground workshops.

4. Facilitators

A key component of the Project Underground program is the workshop leader or facilitator. These participants attend trainings on how to lead the Project Underground workshops mentioned above. These trainings are longer, usually two days, and include a field trip to a karst area. Targeted participants for these workshops include staff from state and federal agencies, soil and water conservation districts, environmental education outreach organization

and interested educators.

The longer Facilitators trainings provide the future workshop leaders with the materials and information needed to run a Project Underground workshop. Handouts on what is in the education guide, colored maps, activity charts and copy pages are given to the facilitators in a workshop leader box. This box contains many of the materials needed to do the activities, for example play dough, sugar, sand, markers, scissors and glue. Individual activity sets are put together so the facilitator can have a variety of activities to demonstrate at a workshop. Participants in the facilitator trainings also learn to create workshop agendas and work with a variety of audiences.

This two-tiered approach in training facilitators and educators through workshops is a good avenue for reaching a large number of students with cave and karst information. If 10 facilitators each lead one workshop with 10 educators then 100 educators are trained to use the Project Underground materials with students in classrooms. If each teacher has a class with 20 students then 2000 students will be introduced to these materials. These students will learn the importance of protecting valuable cave and karst resources.

5. Not just for teachers

Though the Project Underground Natural Resource Education Guide was initially designed for K-12 education, it quickly became apparent that its usefulness extended to other adults as well. Activities such as "Lost River Village" help citizens understand the risks of improper land use on karst, and the importance of careful planning. Activities are used in university classes to introduce karst science and land use issues. Some activities like "Karst Features on a Topographic Map" and "Sinkholes In A Cup" are used in conference presentations and agency staff workshops. Future development of more advanced versions of Project Underground activities should go even further to educate local government officials and agency staff about the importance of karst protection.

Project Underground was designed to be used by other organizations. By incorporating karst science into environmental education programs and karst education into science programs, students and citizens will learn to appreciate and protect fragile karst resources. The Project Underground Natural Resource Education Guide can become a good tool for others to use and build on. One example of this is the Virginia Karst Program in the Virginia Department of Conservation and Recreation. The Project

Underground program is used by the Va. Karst Program to reach teachers as well as agency staff and other education outreach groups. Another example is the Indiana Karst Conservancy committee on Cave Education and Outreach which uses the Project Underground program as one tool in the committee's education events.

Project Underground, Inc. also partners with other cave and karst organizations to help further karst education. The National Speleological Society (NSS) works together with Project Underground through the Environmental Education Committee of the NSS. Cavers are trained with the Project Underground education guide, giving them materials to use in talks and at local outreach events. These cavers are uniquely qualified to teach others about karst issues, having seen the caves and karst resources from the inside. Additional projects with partners have included a National Park Service, where cavers and park staff were trained, and provided with the materials needed, to lead classroom sessions on karst issues in local schools. Project Underground, Inc. also worked with MacGillivray Freeman Films, providing the educational materials for the film "Journey into Amazing Caves."

6. Sponsors

The Richmond Area Speleological Society and the Cave Conservancy of the Virginias are long time sponsors of the Project Underground program and have generously contributed to Project Underground, Inc. Many other organizations have been supportive of the Project Underground program including: The Virginia Department of Conservation and Recreation through the Natural Heritage Karst Program, the National Speleological Society, the National Speleological Foundation, The Cave Conservancy Foundation, the Virginia Region of the National Speleological Society and the Dogwood City Grotto.

7. Conclusion

Project Underground is an environmental education program about karst, which has led to a greater awareness about karst resources and a willingness to prioritize karst protection. Since 1997, over 5000 teachers and educators have received Project Underground materials through

workshops. Over 175 workshops have been held in fourteen states and a solid statewide program has been created in Virginia.

The Project Underground program has been able to expand karst education efforts across much of the United States by targeting educators willing to help with karst education. Teachers use the Project Underground guide in classrooms to reach their students, meeting education standards and building awareness about karst issues. Educators use the Project Underground guide at outreach events reaching a broad cross-section of citizen stakeholders. Facilitators, the workshop leaders, are trained to lead Project Underground workshops and given the supplies needed to do so. Other organizations working with cave and karst issues work with Project Underground, Inc. to help disseminate information and sponsor workshops.

The Project Underground program promotes public involvement and increases public awareness about karst areas and the land use issues unique to these karst areas. Project Underground is working to accomplish the overall vision it has for cave and karst protection by developing and disseminating focused educational materials on the fragile karst environment. This vision of "People will make wise, informed, choices as they manage cave, karst and groundwater resources to protect the underground ecosystems for the health of current and future generations" will be furthered by the karst education program.

References

- Barns, Diane (editor), 1996, Project Underground Natural Resource Education Guide (120 pages): Project Underground, Richmond, VA.
- Zokaites, Carol, 2007, Inquiry Teaching: Asking Questions to Encourage Student Questioning *in* Journal of Virginia Science Education (vol. 2, no. 1, pp. 70-77) Virginia Association of Science Teachers
- Zokaites, Carol, 2006, Project Underground, a Natural Resource Education guide. (3rd ed.).Project Underground, Inc.

THE VIRGINIA KARST EDUCATION PROGRAM

CAROL ZOKAITES and WIL ORNDORFF
Division of Natural Heritage Karst Program
Virginia Department of Conservation and Recreation
8 Radford Street, Suite 102A Christiansburg, VA 24073

Twenty-seven counties in western Virginia are underlain to varying degrees by karst landscapes, including over 4,400 documented caves and dozens of globally rare cave-adapted invertebrates. During the twentieth century, industrial, agribusiness, and rural residential development threatened karst landscapes already impacted by traditional agricultural land use. By the early 1970s, members of the caving community recognized the need for karst protection. In 1979 the Virginia Cave Protection Act was passed, establishing the governor-appointed Virginia Cave Board. Education and outreach efforts by the board led the Virginia Department of Conservation and Recreation's Natural Heritage Program to establish in 1994 a state position devoted karst protection, supported by U.S. EPA Clean Water Act Section 319 funds. The most pressing issue was to develop a broad awareness of the importance of karst among state agency staff, local government officials, and citizen stakeholders. A major component was and continues to be the use of the Project Underground curriculum to train educators both formal (teachers) and informal about karst and how to teach about it in a variety of settings. In 2000, two additional staff, including a dedicated education coordinator, were added forming the Virginia Karst Program.

Education and outreach efforts of the Virginia Karst Program address stakeholder groups from the neighborhood to statewide scale using a variety of formats. On average, ten Project Underground workshops and one facilitator (workshop leader) training reach up to two hundred educators annually. Central to the success of the Project Underground curriculum in Virginia has been the incorporation of basic karst science principles into the Virginia state Standards of Learning (SOLs). The week-long Chesapeake Bay Mountain Academy, now in its fifth year, reaches 20 teachers annually with a detailed look at the biology, hydrology, and geology of the largely karst headwaters region. The Karst Program works with Virginia Tech and local governments to produce Growing Communities on Karst Workshops, where local citizens and government officials come together to discuss the challenges to sustainable development on karst and how to meet them. Trainings are held for agency staff, such as stormwater engineers and nutrient managers, teaching them to recognize and address karst problems encountered in their work. Karst education is incorporated into the Virginia Master Naturalist training in karst areas. Staff regularly makes presentations and holds field excursions for professional organizations such as the Association of Soil and Water Conservation Districts, the Association of Science Teachers, the Association of Professional Soil Scientists, and the Environmental Health Association. The Karst Program also provides guest lectures and field trips for Virginia Tech classes, and helps to guide graduate, undergraduate, and high school research projects. The Karst Education Coordinator sits on the Virginia Resource Use Education Council, providing karst a high profile within the state environmental education community, resulting in collaborative efforts with other member agencies. These efforts have made karst a household word throughout much of western Virginia, and have stakeholders aware and concerned about the impacts of human activity on the interconnected and sometimes fragile karst landscape.

1. Introduction

Caves have been a prominent part of Virginia's culture since colonial times. Organized cave exploration began in the 1940s, and many old cave maps date from the 1950s. By the end of 2008, about 4,500 caves in 27 counties were known to the caving community. Underlying about a quarter of the state, karst aquifers supply water for drinking,

agriculture and industry, and stream and river recharge. In the early days of Virginia caving, most of the karst landscape supported an agrarian economy with a low population that relied on springs and shallow wells for water supply. As the population grew and land use patterns changed, it became clear that many land-use practices had negative impacts upon karst. Citizens, state and local officials, and agency

staff commonly lacked knowledge about the hydrologic importance and environmental sensitivity of karst water supplies.

In the 1970s, members of the caving community spearheaded efforts for legal protection of karst resources, culminating in the passage of the Virginia Cave Protection Act in 1979 (Wilson, 1981). The act outlawed the sale of speleothems and dumping in sinkholes, and shielded landowners from liability for caving accidents, as long as the owner did not charge a fee for access to the cave. The act also specified permit requirements for scientific investigations, and established the governor appointed Virginia Cave Board.

The Cave Protection Act states that the duties of the Cave Board were to advise any requesting state agency on matters relating to caves and karst, maintain a significant cave list and report any real and present danger to such caves, assist in publishing materials on caves and cave-related concerns, and inform the public about the value of cave resources and the importance of conserving them for the citizens of the Commonwealth. The Cave Board worked with the caving community to fulfill these duties and Virginia agencies started hearing the word “karst” and the importance of its protection.

Education projects by the Virginia Cave Board included producing a cave conservation poster titled “In Karstlands ...What Goes Down Must Come Up.” (Kastning and Kastning, 1991). An ongoing Cave Board project is the Cave Owner’s Newsletter, periodically mailed to over 1,500 landowners in Virginia who have caves on their property (Kastning, 1995).

By 1993, the Cave Board’s efforts had opened the eyes of the Department of Conservation and Recreation’s Natural Heritage program staff to the importance of protecting karst. Natural Heritage submitted a successful Projects of Statewide Importance (POSI) Grant Proposal as part of Virginia’s proposal to the EPA Section 319 Clean Water Act fund. DCR established the karst protection coordinator position to educate agency staff and citizen stakeholders about karst resources and the importance of their conservation in protecting water quality and biodiversity. The karst project partnered with Project Underground to offer formal environmental education on karst through workshops across the state.

Working with the Cave Board and the Virginia Speleological Survey, the karst project provided technical

assistance to DCR environmental project review staff, identifying potential impacts to cave and karst resources, and working to develop and implement avoidance, mitigation, and compensation strategies. The karst project also helped revise state stormwater and nutrient management policies to better address karst concerns, provided training to agency staff, and assisted localities in development of ordinances, project review, and long-term planning.

The karst project added significantly to the knowledge of Virginia’s karst by performing dye trace studies, karst feature inventories, and biological collections. Work concentrated in areas rich in biological resources that were threatened by both existing and proposed land use practices.

In 2000, the Karst Project expanded to become the Virginia Karst Program, adding a Karst Protection Specialist and a Karst Education Coordinator. For the first time, this provided state funding for an environmental education position that focused on karst issues.

2. Project Underground

Education is an important part of any natural resource protection plan. It is hard for people to protect something they do not understand. Education is especially important to karst protection since karst is an unfamiliar topic to most people. By making karst education available to the students, citizens and agency personnel in karst areas they will gain the knowledge to help protect this valuable and unique resource.

Education and outreach efforts of the Virginia Karst Program address stakeholder groups from the neighborhood to statewide scale using a variety of formats. Programs are conducted for teachers, agency staff, public planners, students, university classes and many more. Workshops and education materials have been developed and used by citizens and staff from schools to county field days. Training others to teach about or carry out karst protection practices has spread knowledge about Virginia karst resources statewide.

The Project Underground education program has been instrumental in karst protection in Virginia. Project Underground is a learner focused environmental education curriculum that can be used to teach karst science (Zokaites, 2006). Project Underground workshops first train participants in the basics of karst science, then provide lesson plans for teaching that science both in the classroom and informal settings. Karst education materials

are disseminated during these workshops and activities are introduced to the participants, which include both classroom teachers and outreach educators (e.g. park interpreters). Review of these materials and lessons during a workshop helps to ensure their use in the classroom and in outreach programs. The hands on activities mesh well with the inquiry teaching methods used in most science classrooms (Zokaites, 2007). An average of ten Project Underground workshops and one facilitator (workshop leader) training reach up to two hundred educators annually in Virginia.

Formal recognition by the Virginia Department of Education of both the importance of karst science and the role of Project Underground Curriculum in teaching it has been central to the success of karst education efforts in Virginia. Efforts by the karst education coordinator led directly to the incorporation of basic karst science principles into the Virginia State Standards of Learning (SOLs). The science standard for earth science (ES.9) specifically includes the development of karst topography. Standards on groundwater, surface water, habitats, map reading, bats or geologic processes can also be addressed in the classroom through Project Underground activities. Because the Department of Education recognizes Project Underground workshops as official professional development programs, participants can earn continuing education credits. These two factors, combined with the widespread fascination in the topic of caves and karst, help maintain a high level of interest in Project Underground workshops.

Exposing school students to karst science through the Project Underground program helps to create more informed decision makers for the future. When these students later assume roles as citizens and leaders in their communities, they will know the issues land planners and elected officials must address to help protect karst resources. Meanwhile, outreach programs using the Project Underground program introduce adult citizens to the basics of karst science and associated environmental concerns. These citizens in turn encourage the decision makers of today to implement policies and practices protective of karst resources.

3. Chesapeake Bay Mountain Academy

“The Chesapeake Bay is North America’s largest and most biologically diverse estuary, home to more than 3,600 species of plants, fish and animals. For more than 300 years, the Bay and its tributaries have sustained the region’s economy and defined its traditions and culture. It is a resource of extraordinary productivity, worthy of the

highest levels of protection and restoration.” (Chesapeake agreement 2000) The headwaters of several rivers that flow to the Chesapeake Bay lie in the karst topography of western Virginia.

The business plan for Environmental Education in Virginia recommends “*The Commonwealth should build on its Chesapeake 2000 commitment to include all Virginia students in a meaningful outdoor education experience.*” (VRUEC Business Plan) This recommendation is addressed by professional development programs for teachers in the state. The Chesapeake Bay Mountain Academy was established as one of these programs. The Bay Academy addresses the unique issues in the karst landscape and provides knowledge and instructional tools for the teachers to use in the classroom. The teachers participating in the Bay Academy earn continuing education credits and graduate credits from Virginia Commonwealth University.

Funded by a NOAA grant through the Virginia Resource Use Education Council (VRUEC), approximately 20 teachers from across the state spend a week living in cabins at Douthat State Park in the mountains of western Virginia, participating in activities that explore both surface water and groundwater topics characteristic of the headwaters region. Natural resource professionals from a variety of government agencies lead activities on wildlife diversity, water quality, geology, and karst. Several Environmental Education curricula are provided to the teachers, including the Project Underground activity guide. The teachers participate in geology and karst field trips, seeing the impacts of land use practices on water quality and the karst environment. Standing in a sinkhole, visiting the entrance room of a wild cave, and investigating a travertine waterfall flowing from a thermal spring are inspirational experiences that the teachers take back to the classroom. This detailed look at the biology, hydrology, and geology of the largely karst headwaters region of the bay gives the teachers a strong background to teach from. The teachers use the knowledge learned at the Chesapeake Bay Academy to provide meaningful education experiences for their students, combining classroom activities from the curricula with outdoor field experiences.

4. Community Workshops

The Karst Program works with local governments and regional planning commissions to conduct community workshops addressing karst issues. These workshops are customized for the areas in which they are held, emphasizing both the local style of karst and local environmental concerns, ranging from stormwater management associated with urban sprawl to land application of manure and

biosolids to solid waste disposal. These workshops are inclusive, and facilitate dialogue between members of the conservation, agricultural, development and regulatory communities. Workshops commonly include a field component that illustrates the role of karst in protecting water quality and biodiversity, and its sensitivity to inappropriate land use practices.

Particularly successful have been the “Growing Communities on Karst” Workshops, held in conjunction with Virginia Tech and the West Virginia Department of Environmental Protection, where local citizens and government officials have come together to discuss the challenges to sustainable development on karst and how to meet them. These workshops have been held in Shepherdstown and Lewisburg, West Virginia, “bringing together geologists, engineers, land use planners, and remediation specialists to discuss and demonstrate how to manage development pressures in a carbonate rock region” (Growing Communities on Karst 2007). Experts in the various technical fields present case studies and give advice on addressing local issues. These workshops benefit citizen stakeholders, engineering consultants, local governments, and state and federal agency staff. These workshops provide opportunities for networking and partnership building allowing for better stewardship practices to be followed in karst areas. Local citizen and government groups across Virginia are planning additional “Growing Communities on Karst” workshops, reflecting a growing interest on the part of citizens to protect the drinking water and habitats in karst areas.

5. Other Education and Outreach Efforts

The Virginia Karst Program holds in house workshops and trainings for staff in conjunction with the Department of Conservation and Recreation Nutrient Management and Urban Program. These workshops help agency staff recognize karst features in the field, and incorporate protection of these features into nutrient management plans and stormwater facility design. Failures of stormwater management facilities due to karst processes rose over the last twenty years in Virginia due to increasing development on karst landscapes, particularly along the interstate 81 highway corridor. Much of the outreach provided to urban programs staff involves site specific investigations in which technical assistance is provided by karst program staff to help resolve karst related challenges to effective and responsible stormwater management.

The Virginia Karst Program regularly makes presentations to and leads field excursions for professional organizations such

as the Association of Soil and Water Conservation Districts, the Association of Science Teachers, the Association of Professional Soil Scientists, and the Environmental Health Association. For example, at a recent state wide environmental education conference the karst education coordinator presented a talk on Virginia’s bats and the white nose syndrome threatening bats in the northeast part of the United States. DCR staff sponsor an exhibit booth at the Virginia Association of Science Teachers Conference, providing karst education materials and information on the Project Underground program. Over 600 teachers are contacted at this event every year.

The Karst Program also partners with Virginia’s colleges and universities to incorporate karst into both coursework and student research projects. The Karst Program provides guest lectures and field trips to courses in several departments at Virginia Tech, ranging from Geological Sciences to Education to Urban Planning. Staff has helped advise and initiate research projects in Virginia in geology, biology, geography, civil engineering, biological systems engineering and urban planning at Virginia Tech and several other colleges and universities. Projects have included sinkhole hydrology, impaired waters delineation, epikarst hydrology, molecular genetics of troglobytes, geophysics, land use planning and stormwater management. The student researchers working in the karst environment develop an in depth knowledge of certain aspects of karst science, and are likely to be long term advocates for the protection of karst resources.

Another area for education and outreach by the Virginia Karst Program is the Master Naturalist program. “The Virginia Master Naturalist Program is a statewide corps of volunteers providing education, outreach, and service dedicated to the beneficial management of natural resources and natural areas within their communities.” (<http://www.viriniamasternaturalist.org/>) Interested Virginians can acquire certification as Master Naturalists through training and volunteer service. Karst education has become part of both the basic curriculum and advanced training programs for the Master Naturalists in the karst areas of Virginia, using a combination of presentations and Project Underground activities. As these Master Naturalists work as volunteer educators, citizen scientists, and stewards, their basic karst background will ensure karst issues are included as they help Virginians conserve and manage their natural resources.

Karst Program staff works within Virginia’s regulatory and environmental education networks to make sure

karst topics are included wherever appropriate, and that their importance is recognized. The Karst Protection Coordinator holds a permanent seat on the inter-agency Virginia Waters Advisory Committee. The Karst Education Coordinator serves on the DCR environmental education committee, and represents DCR on the inter-agency Virginia Resource Use Education Council (VRUEC), providing karst a high profile within the state environmental education community, resulting in collaborative efforts with other member agencies. The VRUEC brings together

state and federal agencies with private and non-profit organizations to share materials and information.

The Karst Program maintains a web page containing information on karst issues in Virginia. http://www.dcr.virginia.gov/natural_heritage/livingonkarst.shtml This Web site is geared towards karst education with materials for educators to use in workshops, classrooms and outreach events. There are downloadable PowerPoint presentations and factsheets on karst watersheds and karst species,

Activity	Primary Audience Reached	Secondary Audience Reached
Project Underground	Teachers	Students
Workshops	College students Outreach educators	Citizens
Chesapeake Bay Academy	Teachers	Students Parents
University Courses	College students College faculty	Hiring agencies
Professional association workshops and meetings	Environmental professionals Educators Engineers Students	Respective colleagues and clientele
Community Workshops	Local planners Local governments Citizen groups Developers Environmental groups	Local citizens Engineers and other consultants Environmental groups
Master Naturalist Trainings	Citizen Volunteers	Communities State and local agency staff Students
Agency Trainings	Specific regulatory staff Advisory agency staff	Farmers Developers Engineers and other consultants
Karst Program Web site	All of the above	All of the above

Table 1: Summary of Virginia Karst Program education and outreach activities showing primary and secondary audiences

definitions, a section entitled “Bats of Virginia,” and a link to the DCR Project Underground web page. Also containing links to the Virginia Cave Board Web site and the “Living on Karst” publication by the Cave Conservancy of the Virginias, this web page is a good site for the general public to gain knowledge of Virginia’s karst resources.

6. Conclusions

The Virginia Karst Program uses a variety of education and outreach activities to reach a wide range of both primary and secondary audiences, as outlined in Table 1.

In Virginia, education about cave and karst resources is central component in their conservation. From informing people about how the karst systems work to defining the problems caused by land use practices, our education efforts increase the knowledge of citizen stakeholders, elected officials, environmental professionals, and students. Increased awareness of karst resources has lead to the long term advocacy necessary for their protection.

Early efforts in karst education in Virginia helped lead to the creation of the Virginia Karst Program, which in turn expanded karst protection through education and outreach, technical assistance, and data development. Working with the Virginia Cave Board, agency partners and nongovernmental organizations such as the Cave Conservancy of the Virginias, the Virginia Speleological Survey, and the Nature Conservancy, the Virginia Karst Program has increased our understanding of Virginia’s karst systems through dye trace studies, karst feature inventories, and biological monitoring and inventory efforts. This ever growing knowledge base of Virginia’s karst resources combined with workshops offered to state and local agency staff has lead to the development and implementation of avoidance, mitigation, and compensation strategies in the karst regions of the state.

Karst education and outreach activities within the Virginia Karst Program have targeted educators and citizen groups willing to help expand education efforts. Teachers use the Project Underground curriculum in classrooms to reach their students, meeting education standards and building awareness about karst issues. Educators use the Project Underground curriculum at outreach events reaching a broad cross-section of citizen stakeholders. Teachers also include karst resources when teaching about environmental factors affecting the Chesapeake Bay, combining Project Underground activities with other environmental education programs and pointing out the importance of protecting the karst headwaters areas of the Bay watershed. Local

planners, government agency staff, developers and members of citizen groups come together at community workshops on karst, leading to better land management practices in karst areas. Master Naturalists include karst issues as they help Virginians learn about, conserve and manage the state’s natural resources. University research projects, lectures, and fieldtrips help students develop an in depth knowledge of karst science, making them likely to be long term advocates for the protection of karst resources. These education efforts will create informed decision makers who will carry on the protection of Virginia’s karst in the future.

The strong karst education push in Virginia has led to many improvements in karst protection in the state. These efforts have made karst a household word throughout much of western Virginia, and have stakeholders aware and concerned about the impacts of human activity on the interconnected and sometimes fragile karst landscape. Ultimately, the success of this education program will be measured by the attitudes and actions of the citizens, planners, government officials, developers, and land managers as they assume stewardship of Virginia’s karstlands in the years to come.

References

- Kastning, Ernst H., and Karen M. Kastning, 1991, Environmental Education Regarding Karst Processes in the Appalachian Region (pp. 123-134) *in* Ernst H. and Karen M. Kastning, editors, *Appalachian Karst - Proceedings of the Appalachian Karst Symposium, Radford, Virginia* (239 pages): National Speleological Society, Huntsville, AL.
- Wilson, John M., Robert W. Custard, Evelyn W. Bradshaw, Phillip C. Lucas, and John R. Holsinger, 1981, The Evolution of the Virginia Cave Commission *in* *The Brass Light* (no. 7, pp. 53-66) Richmond Area Speleological Society, Richmond, VA.
- Zokaites, Carol, 2007, Inquiry Teaching: Asking Questions to Encourage Student Questioning *in* *Journal of Virginia Science Education* (vol. 2, no. 1, pp. 70-77) Virginia Association of Science Teachers
- Zokaites, Carol, 2006, Project Underground, a Natural Resource Education guide. (3rd ed.). Project Underground, Inc.

Worldwide Web References

- Virginia Department of Conservation and Recreation
Division of Natural Heritage Karst Program

Education

http://www.dcr.virginia.gov/natural_heritage/livingonkarst.shtml

Chesapeake agreement 2000 <http://www.chesapeakebay.net/pubs/chesapeake2000agreement.pdf>

Virginia Resource Use Education Council - Business Plan <http://www.vanaturally.com/vanaturally/businessplan.html>

215

Growing Communities on Karst 2007 <http://www.uap.vt.edu/karst/>

Virginia Master Naturalist Program <http://www.virginiamasternaturalist.org/>

2009 ICS Proceedings

Symposium 3

EVOLUTION AND ECOLOGY OF SALAMANDERS IN KARST

Arranged by:
Andrew Gluesenkamp
Dante Fenolio
Boris Sket

THE BIOGEOGRAPHY AND RAPID RADIATION OF CENTRAL TEXAS NEOTENIC SALAMANDERS

NATHAN F. BENDIK¹ ANDREW G. GLUESENKAMP² PAUL T. CHIPPINDALE³

¹*Watershed Protection and Development Review, City of Austin, P.O. Box 1088, Austin, TX 78704*

²*Texas Memorial Museum, The University of Texas at Austin, 10100 N Burnet Rd., PRC 176/R4000, Austin, TX 78758*

³*University of Texas at Arlington, Biology Department, Box 19498, Arlington, TX 76019*

The neotenic plethodontid salamanders of central Texas include groups that have undergone rapid diversification, and display remarkable morphological variability associated largely with cave or surface habitats. These rapid radiations, coupled with evidence of morphological convergence on habitat-associated morphotypes, make fine-scale phylogenetic inference problematic. To examine evolutionary patterns among the southeastern central Texas *Eurycea*, we used three mitochondrial DNA products (control region, cytochrome *b*, and partial ND2) to reconstruct phylogenetic relationships. Our results indicate that species boundaries recovered in this study are not wholly consistent with previous designations. Additionally, deep divergences among taxa distributed along the Edwards fault zone aquifer suggest that formation of the Edwards Aquifer and compartmentalization within it may have been integral to the early diversification of this group. Subsequent dispersal and diversification probably ensued in the Lower Glen Rose limestone as aquifer and cavern development in this region provided access to novel habitat that was exploited by salamanders. Finally, phylogenetic analysis revealed recurring patterns of morphological convergence among troglobitic populations with cave-associated morphologies.

1. Introduction

Members of the plethodontid salamander genus *Eurycea* in central Texas occur as relictual, disjunct populations confined to springs, caves with water and other underground pools and streams (SWEET, 1982; SWEET, 1984; CHIPPINDALE et al., 2000). Their distribution is confined to the Edwards Plateau, a region of uplifted Cretaceous limestone that has been eroded and dissected over time to form many caves and one of the most productive karst aquifers in the world. The geographic range of central Texas *Eurycea* includes the interior Edwards Plateau exclusive of the Llano uplift (SWEET, 1982; CHIPPINDALE et al., 2000) and extends southwest along the Balcones Escarpment from Bell County to Bexar County and west to Val Verde County.

With very few exceptions, central Texas *Eurycea* are perennibranchiate, obligatory paedomorphs; that is, they do not metamorphose and reproductively mature adults retain gills and other larval features associated with a strictly aquatic life history. The evolution of paedomorphosis within this group is presumed to have been triggered by periods of drought during the Miocene. Xerification of the landscape during this epoch coincided with uplift of the Edwards Plateau (SWEET, 1978) and ancestral biphasic populations persisted only in relatively scarce mesic areas such as deep canyons and spring outflows. Under this scenario, the current taxonomic diversity observed in this

clade is likely the result of allopatric speciation facilitated by a serendipitous combination of climatic conditions, geologic change, and life history. Members of this clade are restricted to sites with permanent water and have relatively small geographic ranges and confinement to an aquatic life history in a xeric region may explain the considerable species diversity within this group, some of which has only recently been recognized (e.g., five recent species descriptions in: CHIPPINDALE et al., 1993; CHIPPINDALE et al., 2000; HILLIS et al., 2001) while additional species are still awaiting description (CHIPPINDALE et al., 2000; unpublished data).

The central Texas *Eurycea* display a remarkable degree of morphological variation which tends to be habitat-associated. Epigeal populations (those inhabiting surface waters) are found in springs, areas around spring outflows, and first order streams typically have an appearance similar to that of the larvae of other spelERPINES (SpelERPINAE is a subfamily of the family Plethodontidae and occurs in eastern North America; CHIPPINDALE et al., 2004). Hypogean populations (those inhabiting subterranean aquatic habitats), however, exhibit a range of morphological features. The most extreme examples of cave-associated morphologies exhibited by central Texas *Eurycea* salamanders are *E. rathbuni*, *E. robusta*, and *E. waterlooensis*. These species have skin that lacks nearly all dark pigmentation; reduced eyes; thin, elongate limbs;

shortened trunks (relative to other Texas *Eurycea*); and elongated, flattened snouts (POTTER AND SWEET, 1981). Additionally, the degree to and frequency of which these cave-associated morphological traits are expressed varies among hypogean *Eurycea* populations (reported in great detail by SWEET, 1984). Morphological similarities among populations that occur in similar habitats (surface or subterranean) misled earlier taxonomists into grouping salamanders with comparable phenotypes, as well as separating those with dissimilar phenotypes (e.g. WAKE, 1966). Molecular systematic techniques have been integral in helping scientists resolve relationships among the central Texas *Eurycea* (CHIPPINDALE et al., 2000; HILLIS et al., 2001).

Here we present further study of the evolutionary history of a subgroup of central Texas spring and cave salamanders (southeastern *Blepsimolge*; HILLIS et al., 2001) using molecular markers to reconstruct their phylogenetic relationships. From this phylogenetic pattern, we examine how geologic and hydrogeologic history may have influenced speciation and morphological variation in this group.

2. Methods

Salamanders were collected from spring and cave sites within the Edwards Plateau region between 1988 and 2005. Many samples used by CHIPPINDALE et al. (2000) are included within this study, in addition to specimens from numerous recently discovered populations. Specimens collected during the course of this study were euthanized with MS-222, and tissues taken according to approved IACUC protocols. The species included in this study, following the revisions given by CHIPPINDALE et al. (2000) are: *E. latitans* complex, *E. pterophila*, *E. nana*, *E. neotenes*, *E. tridentifera*, *E. troglodytes* complex, *E. sosorum*, *E. sp.* Pedernales, *E. sp.* Comal Springs and *E. rathbuni* (outgroup). All specimens collected prior to 2003 are deposited in the Texas Natural History Collection (Texas Memorial Museum, University of Texas at Austin). All specimens collected from 2003 to 2006 are deposited in the Amphibian and Reptile Diversity Research Center at the University of Texas at Arlington.

DNA was extracted from muscle or liver tissue using several standard methods (WALSH et al., 1991; QIAGEN, 2003). PCR products were amplified primarily using a generic *Taq* polymerase (New England Biolabs) or Hot Start *ExTaq* (Takara) on MJ Research PTC 200 gradient and PTC 100 thermal cyclers. Amplification for PCR and sequencing was performed using a variety of primers designed in house (not shown here) for the mitochondrial markers ND2,

cytochrome *b*, control region (CR) and inter-genic spacer (IGS). For more detailed information on PCR and thermal cycling conditions, see BENDIK, 2006.

Raw sequence chromatograms were edited with Sequencher (Gene Codes Corp.). The ClustalW algorithm was used to perform multiple alignments of the nucleotide sequences, and alignment gaps within the CR and IGS were adjusted manually. Two repeat regions within the IGS were removed from the alignment because this region exhibits substantial intrapopulation variation and heteroplasmy in number of repeats. Analyses were performed using a combined dataset of ND2, cytochrome *b*, and CR+IGS. *Eurycea rathbuni* was chosen as the outgroup for all analyses because it (plus *E. waterlooensis*) is well supported as sister to *Blepsimolge* in previous molecular studies (CHIPPINDALE et al., 2000; HILLIS et al., 2001; WIENS et al., 2003).

Modeltest v3.7 (POSADA AND CRANDALL, 1998) was used to select the appropriate models of evolution under the Akaike Information Criterion for implementation in Bayesian phylogenetic analyses (POSADA AND BUCKLEY, 2004). MrBayes v3.1 (HUELSENBECK AND RONQUIST, 2001) was used to perform the Bayesian analyses. MrBayes allows for partitioning of data to assign different evolutionary model parameters. Partitioning by codon improved likelihood scores over partitioning by the entire gene, so we employed this scheme for both protein coding regions. Both maximum parsimony and haplotype network analyses were completed in addition to a Bayesian phylogenetic analysis; however those results will not be presented here due space limitations. We briefly note where these analyses differed from the Bayesian analysis, although the differences do not affect our conclusions.

3. Results and Discussion

A total of 61 individuals collected from 43 caves and springs throughout the eastern Edwards Plateau are included in this study. The total length of the final alignment was 3252bp. Parsimony and Bayesian analyses differed on the placement of several problematic taxa, although these results were not strongly supported in either analysis.

The following abbreviations in bold are used to refer to clades in figures and in text: **N**, *E. neotenes* and closely related populations; **W**, population at White Spring; **FT1**, clade 1 of populations within the Fort Terrett formation; **FT2**, clade 2 of populations within the Fort Terrett formation; **SE**, clade of *E. pterophila* and closely related populations with a southeastern distribution (relative to all *E. pterophila*); **NW**, clade of *E. pterophila* and closely

related populations with a northwestern distribution; **LT**, *E. latitans*, *E. tridentifera*, and other closely related populations; **P**, group inclusive of all *E. pterophila* and related or geographically proximate populations; **LTP**, *E. latitans*, *E. tridentifera*, *E. pterophila* and related populations, inclusive of clades FT2, LT and P.

The phylogenetic pattern from the combined analysis does not correspond completely with currently recognized species boundaries: populations of *E. latitans* do not form a monophyletic group and all *E. tridentifera* appear to be conspecific with or at least nested within topotypical (and other) *E. latitans*; *E. pterophila* form a poorly supported monophyletic group in the Bayesian analysis (Fig. 1) and was not recovered as a monophyletic group under parsimony, but was recovered by the haplotype network.

While a detailed morphological analysis is underway,

cursorry observation indicates that salamanders with cave-associated morphological features (e.g. reduced eye diameter and elongated snout) do not form a monophyletic group. The phylogenetic positions of troglomorphic salamanders within the southeastern Blesimolge are consistent with a pattern of morphological convergence or parallelism, whereby species in similar habitats (or exposed to the same selective pressures) independently evolve similar dimensions of traits (WIENS ET al., 2003). This pattern can be observed by comparing the phylogenetic position and troglomorphic features of Preserve Cave (clade SE) and *E. tridentifera* (clade LT; Figs. 1 and 2). Less clear is the origin of troglomorphism within the LT clade. One possible interpretation of this pattern is that cave-associated characters are evolving faster than lineage sorting. If these cave-associated traits can evolve at such a rapid pace, there is no reason why troglomorphism could not have arisen independently several times within this clade. However,

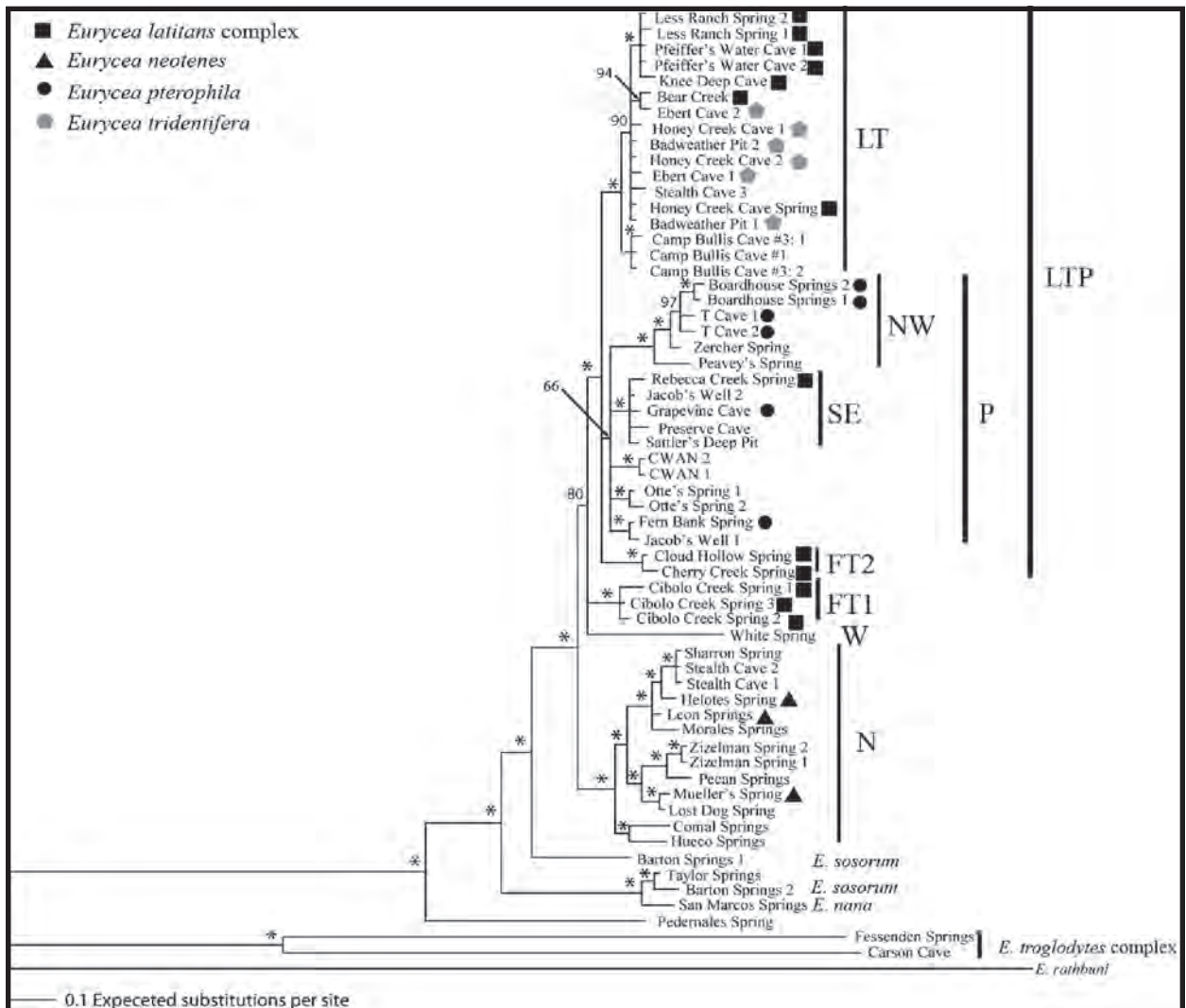

Figure 1: Phylogram resulting from the Bayesian analysis. See text for explanation of abbreviations.



Honey Creek Cave



Preserve Cave



Camp Bullis Cave 3

Figure 2: Photographs of troglomorphic *Eurycea* from populations represented in this study.

given the presence of numerous cave populations that do not appear to exhibit extreme cave-associated morphologies (e.g. Knee Deep Cave, CWAN, Jacobs Well, T Cave, Pfeiffers Water Cave) this does not seem like a plausible explanation unless these caves are very young or salamanders invaded them recently. Alternatively, balancing selection may be acting within LT, preserving both epigeal and troglotic morphologies within the population. The evolution of cave-associated features may have arisen independently and later those populations hybridized with surface dwelling populations. This would be similar to the scenario proposed by SWEET (1984) for Cascade Caverns (which exhibited a spectrum of morphologies), although he considered the surface and cave forms to be distinct species.

Several major vicariant events that established distinct lineages of the southeastern Blepsimolge probably occurred within the Edwards fault zone springs and caves. These correlations between deep phylogenetic splits and current distribution are suggestive of the importance and influence that Edwards Aquifer development had on the evolution of central Texas *Eurycea*. Faulting during the late Early Miocene (YOUNG, 1972) had a major impact on the formation of the Edwards Aquifer, controlling cavern development (WOODRUFF AND ABBOTT, 1979), and producing major discharge points at San Marcos, Comal and Barton Springs. Fig. 3 depicts the relationships among the southeastern Blepsimolge and their distribution with respect to the Edwards and Trinity Aquifers. The large springs in the Edwards Aquifer, and the aquifer itself, may have provided a persistently stable habitat throughout the history of this group. If the most recent common ancestor of *Eurycea* inhabiting the Edwards Aquifer was once widespread throughout it, faulting or other disruptions cutting off connections within the aquifer, and consequently limiting or

ceasing gene flow among *Eurycea*, may have been the cause of cladogenesis and speciation in the early history of the southeastern Blepsimolge.

Several biogeographic patterns within the southeastern Blepsimolge are apparent. Species and clade boundaries are not demarcated by river basins; they are more closely correlated with geologic features. *Eurycea latitans* and *E. tridentifera* are distributed throughout the Cibolo Creek basin and to the south side of the Guadalupe River. The range of *E. pterophila*, restricted to the Blanco River drainage by CHIPPINDALE et al. (2000), actually extends into the Guadalupe basin as well. The area inhabited by the southeastern Blepsimolge can be characterized by three major geologic formations: the Edwards group and the Upper and Lower Glen Rose formations. The distribution of *E. pterophila*, *E. latitans*, and *E. tridentifera* occurs primarily in the karstified Lower Glen Rose, and *E. neotenes* inhabits the periphery of this area to the south, mostly within the Edwards Limestone region (Fig. 4).

The most recent common ancestor of N and LTP (Fig. 1) may have been distributed throughout the now exposed Glen Rose formations prior to cladogenesis (Fig. 4). Following events of erosion, possibly cutting off hydrologic connections among populations, divergence among clades ensued. The vicariant event separating N from LTP was probably the exposure of the Lower Glen Rose and subsequent aquifer and cavern development within this region. This is consistent with their current distribution; *E. neotenes* are mostly restricted to Edwards Limestone along the Balcones escarpment. The least divergent but most widely distributed group, the LTP clade, inhabits the Blanco, Guadalupe, and Cibolo drainages. Relationships between the P and LT clade are unresolved and divergence between these groups is low. This is probably a reflection of a very rapid radiation within this group which probably occurred during karstification of the Lower Glen Rose formation in the Guadalupe and Cibolo watersheds (1.3ma to 990 ka B.P.; VENI, 1994), which would have allowed for dispersal and vicariance through newly formed caves and springs in this region.

The LT clade has a seemingly disjunct distribution, primarily occurring in caves and springs of the Cibolo Sinkhole Plain but extending northward towards the Guadalupe River into Honey Creek Cave and Knee Deep Cave. This distribution may be explained by a water pirating route from Cibolo Creek to the Guadalupe River through Honey Creek Cave which was established in the early stages of the evolution of the Honey Creek Cave system, approximately 1.2 ma

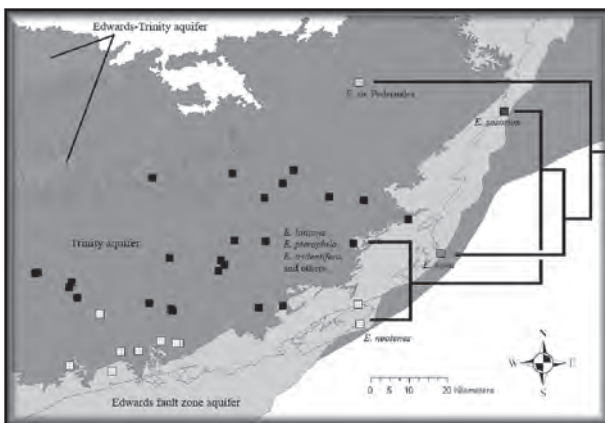

Figure 3: Relationships among the major groups of the southeastern Blepsimolge and their distribution with respect to the major aquifers of the Edwards Plateau.

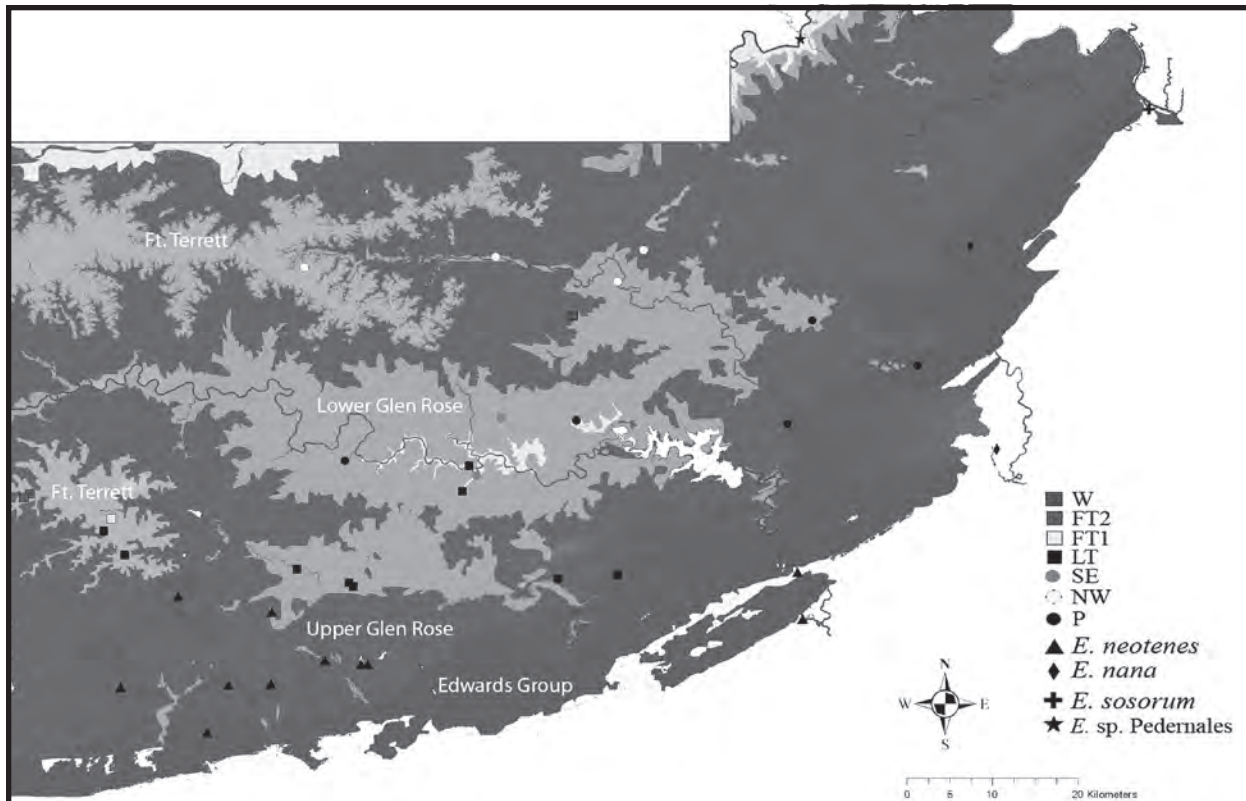

Figure 4: Distribution of southeastern *Blepsimolge* with respect to the major exposed geologic formations of the Edwards Plateau.

B.P. (VENI, 1994). Several populations belonging to this clade do not occur within the Lower Glen Rose karst, but in an isolated patch of the Fort Terrett formation (part of the Edwards group). Less Ranch Spring is adjacent to the boundary of the Fort Terrett and Upper Glen Rose formations and Bear Creek spring occurs in the Fort Terrett formation and in a drainage basin opposite other *E. latitans*, although extremely close to the Cibolo Creek Spring locality. Two other somewhat anomalous groups occur in this region as well. The position of the Cibolo Creek Spring clade (FT2) is poorly resolved in the phylogenetic tree, forming a polytomy with White Spring (W), LTP and FT2. Cloud Hollow and Cherry Creek (FT1) are monophyletic and part of a polytomy with P and LT. It seems that several cladogenic events are correlated with the erosion and possible separation of hydrologic units within this Fort Terrett “island.” Further resolution of the phylogeny would likely benefit from the addition of *Eurycea* from localities in this area.

4. Conclusions

Eurycea of central Texas exhibit an array of genetic variation with puzzling patterns of morphological diversity at several phylogenetic levels. While current taxonomic designations are not wholly consistent with the results presented here, these results are preliminary and further

investigation is warranted to determine the possible causes of this apparent convergence and rapid evolution of cave-associated morphological traits. Regardless of the outcome, it is clear that the evolution of the central Texas geologic and hydrologic region has facilitated the speciation and cladogenesis of this unique group of salamanders.

Acknowledgements

Thanks to Anthony Kappell, Huong Pham, Tolu Bakare, Weldon Turner, Kat Ivanova, John Adams and PCR Jesus for laboratory assistance. A number of people assisted with specimen collection or provided specimens for this study including Rebecca Calisi, Andy Gluesenkamp, David Hillis, Jean Krejca, Lauren Lucas, John Malone, and Kenny Wray. Travis LaDuc and Brian Sullivan were helpful in obtaining specimen tissue and DNA from TNHC at UT Austin. Thanks to these funding sources: UTA Biology Department, UTA College of Science, UTA Phi Sigma Society, the Austin Community Foundation and The City of Austin.

References

- Bendik, N. F. 2006. Population genetics, systematics, biogeography, and evolution of the southeastern central Texas *Eurycea* clade Blepsimolge

- (Plethodontidae). Unpublished Master's Thesis. University of Texas at Arlington, Arlington, Texas, U.S.A.
- CHIPPINDALE, P.T., A.H. PRICE, and D.M. HILLIS. (1993) A new species of perennibranchiate salamander (*Eurycea*: Plethodontidae) from Austin, Texas. *Herpetologica* **49**, 248–259.
- CHIPPINDALE, P.T., A.H. PRICE, J.J. WIENS, and D.M. HILLIS. (2000) Phylogenetic relationships and systematic revision of central Texas hemidactyliine plethodontid salamanders. *Herpetological Monographs* **14**, 1–80.
- HILLIS, D.M., D.A. CHAMBERLAIN, T.P. WILCOX, and P.T. CHIPPINDALE. (2001) A new species of subterranean blind salamander (Plethodontidae: Hemidactyliini: *Eurycea*: *Typhlomolge*) from Austin, Texas, and a systematic revision of central Texas paedomorphic salamanders. *Herpetologica* **57**, 266–280.
- HUELSENBECK, J P., and F. RONQUIST. (2001) MRBAYES: Bayesian inference of phylogeny. *Bioinformatics* **17**, 754–755.
- MITCHELL, R.W., and J. R. REDDELL. (1965) *Eurycea tridentifera*, a new species of troglobitic salamander from Texas and a reclassification of *Typhlomolge rathbuni*. *Texas Journal of Science* **17**, 12–27.
- MITCHELL, R.W. and R. E. SMITH. (1972) Some aspects of the osteology and evolution of the neotenic spring and cave salamanders (*Eurycea*, Plethodontidae) of central Texas. *Texas Journal of Science* **23**, 343–362.
- (2004) Model selection and model averaging in phylogenetics: advantages of the AIC and Bayesian approaches over likelihood ratio tests. *Systematic Biology* **53**, 793–808.
- POSADA, D., and K. A. CRANDALL. (1998) Modeltest: testing the model of DNA substitution. *Bioinformatics* **14**, 817–818.
- POTTER, F.E. JR., and S. S. SWEET. (1981) Generic boundaries in Texas cave salamanders, and a redescription of *Typhlomolge robusta* (Amphibia: Plethodontidae). *Copeia* **1981**, 64–75.
- Sweet, S.S. (1978) The evolutionary development of the Texas *Eurycea* (Amphibia: Plethodontidae). Ph.D. Dissertation, University of California, Berkeley, California, U.S.A.
- SWEET, S.S. (1982) A distributional analysis of epigean populations of *Eurycea neotenes* in central Texas, with comments on the origin of troglobitic populations. *Herpetologica* **38**, 430–444.
- SWEET, S.S. (1984) Secondary Contact and Hybridization in the Texas Cave Salamanders *Eurycea neotenes* and *E. tridentifera*. *Copeia* **1984**, 428–441.
- Veni, G. (1994) Geomorphology, hydrology, geochemistry, and evolution of the karstic lower Glen Rose aquifer, south-central Texas. Ph.D. Dissertation, Pennsylvania State University, University Park, Pennsylvania, U.S.A.
- Wake, D.B. (1966) Comparative osteology and evolution of the lungless salamanders, family Plethodontidae. *Memoirs of the Southern California Academy of Sciences* **4**, 1–111.
- WIENS, J.J., P.T. CHIPPINDALE, and D. M. HILLIS. (2003) When are phylogenetic analyses misled by convergence? A case study in Texas cave salamanders. *Systematic Biology* **52**, 501–514.
- Woodruff, C.M. Jr. and P.L. Abbott. (1979) Drainage-basin evolution and aquifer development in a karstic limestone terrane, south-central Texas, USA. *Earth Surface Processes* **4**, 319–334.
- Young, K. (1972) Mesozoic history, Llano region. In V. E. Barnes, W. C. Bell, S. E. Clabaugh, P. E. Cloud, Jr., R. V. McGehee, P.U. Rodda, and K. Young, (eds.), *Geology of the Llano region and the Austin area*, Bureau of Economic Geology Guidebook No. 13, University of Texas, Austin, 77p.

BIOGEOGRAPHY AND EVOLUTION OF SUBTERRANEAN SALAMANDERS

RONALD M. BONETT¹, DANTÉ FENOLIO²

¹*University of Tulsa, Department of Biological Sciences, 800 S. Tucker Dr., Tulsa, OK 74104*

²*Atlanta Botanical Garden, Center for Conservation, 1345 Piedmont Ave., Atlanta, GA 30309*

Abstract

Multiple lineages of salamanders have independently colonized karst systems, and the nature of the association ranges from occasional or seasonal karst dwelling populations to obligate subterranean species. Using a molecular phylogeny of salamanders we examine the distribution and timing of evolution of partial and obligate cave dwelling salamanders. We also utilize phylogenetic comparative methods to further test if intrinsic attributes of different salamander lineages make them more-or-less likely to colonize and become tied to karst systems.

TEXAS CAVE AND SPRING SALAMANDERS (*EURYCEA*): NEW DISCOVERIES AND NEW SURPRISES

PAUL T. CHIPPINDALE¹, ANDREW G. GLUESENKAMP², NATHAN F. BENDIK³

¹Biology, University of Texas at Arlington, Arlington, TX 76019

²University of Texas at Austin, Austin, Texas 78758

³City of Austin, Austin, Texas 78704

Abstract

Salamanders of the genus *Eurycea* in central Texas are restricted to springs and water-containing caves in the karst of the Edwards Plateau, representing a unique evolutionary radiation of numerous paedomorphic (non-transforming) species. Determination of species boundaries and phylogenetic relationships has been complicated by lack of morphological differentiation among many members of the group, and convergent evolution of cave-associated morphologies in lineages that independently colonized subterranean habitats. Most species have been described only recently, others currently are being described, and new species continue to be discovered even in rapidly developing urban areas.

We are using a wide range of molecular markers (mitochondrial and nuclear DNA sequences, microsatellites, and allozymes) plus morphological and morphometric analyses to investigate fine-scale divergences in the group at a nearly unprecedented breadth and level of detail for karst-dwelling organisms. Our wide-scale findings so far are consistent with the major results of our and other colleagues' studies in the last two decades: there is an extremely deep split between the "northern" and "southern" groups corresponding to the divide of the Colorado River (about 15 million years' divergence); the *Typhlomolge* clade (now formally assigned to *Eurycea* under the Linnean classification system) is the sister group to other southern *Eurycea*; the southern group is divided into southeastern and southwestern components; and both the southern and northern groups contain multiple species. However, our recent work has revealed even more distinct evolutionary lineages than previously suspected, with major differentiation on a scale of as little as a few hundred meters. The extreme troglomorphs of the *Typhlomolge* clade exhibit surprising levels of molecular variation and are more geographically widespread than previously known.

We also have found complex patterns of past and ongoing hybridization among members of the group that diverged millions of years ago, indicating that rather than being a group of allopatric or parapatric species separated by clear-cut hydrogeological and ecological boundaries, this is an evolutionarily dynamic system in which (in some cases) intermittent gene flow may be an important determinant of genetic and phenotypic diversity. The more that we study this group, the clearer it becomes that the diversity we see is not simply the result of past geological events, but instead reflects continuously changing subterranean corridors in the Edwards Aquifer. No doubt, this affects other aquifer-dwelling organisms as well, and long-term studies of genetic variation in the salamanders coupled with independent monitoring of aquifer flow patterns will be integral to preservation of both subterranean habitat and water resources essential to people in the region.

SAMPLING ELUSIVE SPECIES IN KARST ENVIRONMENTS: DESIGN AND DEMOGRAPHIC MODELING CONSIDERATIONS

BRET A. COLLIER¹, DANTE B FENOLIO²

¹*Institute of Renewable Natural Resources, Texas A&M University, College Station, Texas 77843*

²*Atlanta Botanical Garden, Center for Conservation Research, 1345 Piedmont Ave, Atlanta, GA 30309*

One of the primary difficulties associated with populations endemic to cave ecosystems is estimating basic biological parameters such as abundance, survival, and recruitment. As many karst systems can be perturbed, determining estimates of demographic variables are central to evaluating whether anthropogenic or environmental influences cause variation in population distribution and trajectories. Currently, sampling design and inference methods for demographic parameters are readily available and widely applied to a range of terrestrial fauna. Our objective is to provide an overview of potential sampling designs and demographic estimation methodologies which would be amenable for use on a variety of subterranean species. We will discuss concepts associated with spatial and temporal constraints contingent on the biology of the species under study, provide examples of potential sampling designs applicable to subterranean systems, and outline estimation techniques addressing issues associated with estimation of observability, presence/absence, abundance, survival and recruitment estimation, and transience associated with temporary and permanent emigration. While general and applicable, few sampling designs or modeling applications have been applied to karst species, likely due to perceived difficulties associated with low species abundance, limited spatial and temporal distribution, and unobservable states. However, we suggest that further investigation be directed towards design and application of common estimation approaches to further our understanding of the fauna existing in subterranean ecosystems.

1. Introduction

Scientific research is frequently driven by hypotheses-based experimental studies on mechanisms impacting populations across their range. Experimental studies where system perturbations are planned and implemented necessitate a much different design than studies focused on inventory or monitoring. However, perhaps the most difficult but most important part of developing a study is explicitly defining what the survey's focus will be and how those data will be used to evaluate population trajectory and demography. Logistical limitations, such as those found in most cave environments, will limit researchers to mensurative designs in lieu of replicated experimentation. However, mensurative research can provide a wealth of information on population dynamics and the causal relationships between environment and demography. Thus, as ecologists, our objective is to collect and use information to make inferences regarding population growth, trajectory, or demography (Thompson et al. 1998). However, as complete enumeration of populations is infeasible in most cases, we rely on a combination of sampling survey design and model-based inferences to maximizing information collected on populations of interest while minimizing costs of the sampling effort (Thompson 2002).

The primary difficulties in studying cave environments are associated with sampling designs and resulting demographic inferences (Benedetti-Cechi et al. 1996, Culver et al. 2004). Sampling designs for cave systems have similar limitations as those found in terrestrial or marine systems; thus cave sampling designs must address general issues associated with spatial configuration across landscapes and within unique cave systems, temporal variation associated with seasonality of resources within cave systems, and enumeration variation, or the inability of ecologists to accurately census populations. However, specific issues affecting sampling in cave systems differ from those found when sampling terrestrial or marine systems. For example, cave systems may be more buffered from climactic changes or seasonal extremes (Dowling, 1956; Poulson and Culver, 1969; Barr and Holsinger, 1985; Fenolio et al. 2005), but, issues of sample survey coverage and detectability are paramount to demographic studies of cave organisms (Schneider and Culver, 2004). Our focus within this paper is to discuss some general topics relating to sample survey design and resulting inference and to discuss several approaches which might be amenable for cave systems. Obviously our review will not be all encompassing of all literature on both sampling and caves, but we will note alternative literature for the interested reader.

2. Study Focus

When designing a study to evaluate population dynamics, the study species is perhaps the most important factor on which to base design decisions. After posing a question and reviewing literature, one must determine study feasibility based on a host of factors. Research questions and survey designs for species of interest which are widely distributed in low abundance differ from species which are restricted in range and locally abundant. Accessibility to the target population's habitats are requisite, although structural or spatial limitations will influence observability of the target population. In addition, given we can access habitat where the species is expected to be located, the next questions are addressed. First, is the species present or absent? If present, can we allocate enough effort to adequately sample the species, e.g., are we able to catch/locate the species on a regular basis? Each of these questions must be addressed and answered, via either literature review or a pilot study (Thompson et al. 1998) before intensive efforts studying population dynamics are attempted.

Because our ability to experimentally perturb cave systems is somewhat limited, we often focus on different forms of population assessment as a way to evaluate population state(s). Monitoring is critical to our understanding of factors causing variation in populations as monitoring allows for population assessments over time and space (Thompson et al. 1998, Yoccoz et al. 2001) and provides the ability to readily identify conservation issues and potential solutions (Thomas 1996). Inventories typically measure population status during the survey period, but are not concerned with persistence, size, or mechanism affecting population change after the survey period. Inventories often focus on species richness or diversity (Nichols et al. 1998, Cam et al. 2002, Schneider and Culver 2004). Inventories can also focus on species abundance within a cave during a single time frame (Benedetti-Cecchi et al. 1996). Within the context of monitoring, when future impacts are temporally and spatially defined, impact assessments can be used to determine what effects perturbations have on populations. Impact assessment require explicit knowledge of the upcoming disturbance, otherwise sub-optimal designs are warranted (Morrison et al. 2008). However, using long-term monitoring, we suggest that impact assessments can be used to correlate changes in populations to biological (Fenolio et al. 2005; Fenolio et al. 2006) or anthropogenic (e.g., Schwartz, 1976; Crunkilton, 1984; Weaver, 1987) phenomenon.

3. Sample Survey Design for Observational Research

Because we cannot assume a census when studying

natural populations, the primary purpose of sampling is to collect data from a randomly selected subset of the population of interest and use those data to estimate population parameters (abundance, survival, recruitment) while accounting for nuisance parameters (observability, detectability) and evaluating the impacts of process-based (temporal and spatial) and sampling-based (enumeration) variation (Thompson et al. 1998, Williams et al. 2002, Morrison et al. 2008). Inductive inference and measurements of uncertainty are tied to probabilistic sampling designs (Cochran 1977), and non-probabilistic sampling based on judgment/convenience do not allow for valid inference to be made regarding the study population. Because the range of sampling and inference topics which could be associated with sampling troglobitic/stygobitic populations are extensive, we will focus on applications that illustrate methodologies we suggest would be applicable. We acknowledge that this list is not all-encompassing, and that alternative designs should be evaluated.

4. Designs for Parameter Estimation

Currently, there are countless approaches for estimating population demographic parameters (e.g., occupancy abundance, survival, recruitment, fidelity) as well as nuisance parameters (detection or capture probabilities) when a complete census is infeasible or impossible. When designing a study to track the dynamics of a natural population over time and space, it is highly unlikely to expect that you will detect all of the organisms of interest within your sampling frame. The issue of detection probability has permeated the field of population dynamics research recently with both manuscripts and books highlighting the importance of estimating detection (Anderson 2001, 2003, Thompson 2002, Williams et al. 2002, Thompson 2004, Morrison et al. 2008). Estimation of nuisance parameters has become pervasive in ecological literature, often superseding discussion of population parameter of interest as demographic parameters can rely on multiple nuisance parameters for accurate prediction. As a simple example outlining the necessity of estimating nuisance parameters, consider the general estimator provided by Pollock et al. (2004) which addresses issues associated with observability of the sampled population, via both detectability and availability to be detected. The estimator from Pollock et al. (2004)

$$\hat{N} = \frac{C}{P_{area} \hat{p}_a \hat{p}_{d|a}}$$

where \hat{N} is the population size, C is the uncorrected count or population index, P_{area} is the proportion of the total area surveyed, \hat{p}_a and $\hat{p}_{d|a}$ represent the probability of

being available for sampling, and for being detected given that the species was available to be sampled, respectively. The historical approach would be to equate $\hat{N} = C$ under the aforementioned assumptions. However, $\hat{P}_{d|a}$, \hat{P}_a , and P_{area} each have different ramifications for estimates of \hat{N} . Not accounting for the amount of an area available for sampling (P_{area}) would only allow inferences to be made to the available component of a population (Pollock et al. 2004) while ignoring the effects of $\hat{P}_{d|a}$ and \hat{P}_a would likely bias estimates of \hat{N} low (e.g., as $\hat{P}_i \rightarrow 1$ then $C \rightarrow \hat{N}$). The primary reason we chose this example is that this general estimator highlights the need to account for sample availability (observability and detection), which we see as being issues paramount to study of subterranean species in environments which we will discuss in the next section.

Because complete enumeration of natural populations is difficult, biometricians have developed a suite of methods appropriate for estimating population demographic parameters based on capture-recapture of marked individuals. In capture-recapture studies, populations are sampled >2 times with individuals are marked upon capture and the frequency of recapture of marked and unmarked individuals is recorded during each occasion. Marks can be based on unique characteristics of individuals, PIT (passive integrated transponder) tags, radio-tags, genetic tags, unique vocalization, repeated observation, and a host of other marking techniques (Morrison et al. 2008, pp. 175). Typically, recaptures occur through harvest, trapping, resighting (Williams et al. 2002). There are typically 4 population parameters of primary interest to ecologists; abundance, survival, and recruitment, and immigration/emigration rates. Methods available for estimating these parameters are not mutually exclusive, but can be broken into general categories of closed and open population models (Amstrup et al. 2005) with different approaches falling under each type (e.g., closed captures, multiple observers, Cormack-Jolly-Seber) and several approaches that combine different methods to estimate a set of parameters from the same data (e.g., robust designs, multi-state models) (see Amstrup et al. (2005; pp. 4) for a methods flowchart). While we focus our discussion of parameter estimates on models for abundance, survival, and recruitment using on capture-recapture style approaches, we also note that a variety of techniques for estimating abundance that do not rely on capture-recapture approaches are available (Williams et al. 2002).

The Peterson-Lincoln model is one of the original population abundance estimator models and is the forerunner of all current modeling applications. Under

the Peterson-Lincoln model, a sample (n_1) is captured, marked, and released during the first sampling occasion (t_1). A second sample (n_2) is taken at a later time (t_2), and the number of previously marked individuals recaptured (m_2) are recorded. Using these data, population size is estimated as $\hat{N} = n_1 n_2 / m_2$. Based on this original design, closed capture population models (Otis et al. 1978) are used when the researcher is confident that the population in question is unchanged due to births, deaths, or movements into and out of the population during the survey period(s). Closed capture models have expanded from addressing issues associated with variation due to behavioral or temporal factors to a class of models which now allow for evaluations of heterogeneity associated with groups, classes, states, or values unique to individuals (Williams et al. 2002) and have been expanded for either discrete or continuous time modeling (Chao and Huggins 2005). Closed capture models are highly flexible and can be applied not only to situations where individuals are captured and released, but to systems based on multiple-observer surveys as well (double observers, Nichols et al. 2000).

Determining viability of populations often requires information on survival and recruitment, which, when combined with estimates of abundance would allow researchers to model populations dynamics over time. Estimation of survival and recruitment requires models that relax the assumption of population closure (no movements in or out of a population during the sampling period). Thus, population models which allow modeling of gains based on reproduction/emigration and losses due to mortality and emigration are described as open models. Open population models have been developed under variety of different modeling methods and assumptions over the past 50 years. Open population models using the Cormack-Jolly-Seber (CJS) parameterization are conditioned on the capture and release of marked individuals within the population (Williams et al. 2002), while Jolly-Seber parameterizations include an additional component for modeling unmarked individuals in the population (Nichols 2005). Another option for recruitment estimation is based on reverse-time models (Nichols et al. 2000) or an application of common CJS models wherein by reversing the capture histories and conditioning on the individuals captured during the last time period, inferences can be made on recruitment rates into the population and the various importance of recruitment or survival to population growth rates.

Modeling approach we suggest, which use marked individuals and are very applicable to sampling and demographic parameter estimation in karst environments,

are those using robust designs. Robust design modeling (Pollock 1982, Kendall et al. 1995) is an approach in which open and closed models are combined; wherein, periods having short times between sampling events are modeled as closed populations and time between these periods are modeled as open populations. Hence, estimation of abundance and capture probabilities can be garnered from the closed periods, while estimates of survival and recruitment can be determined using data collected from individuals captured between the closed periods (i.e., the open periods). Use of robust design models is well suited for cave systems in that questions regarding population size can be addressed using the 'closed' sampling periods. As a brief example, imagine sampling in a system where salamanders are seasonally clustered in a known portion of the subsurface habitat (Fenolio et al. 2006; Fenolio et al, in prep). Optimally we suggest structuring the secondary sampling period to occur when salamanders are clustered, due to available resources. The primary sampling periods could occur annually or seasonally or given some time frame that is biologically relevant for estimating survival and movements. Estimation of gains and losses to the populations will be determined over the primary periods while abundance is estimated over the secondary periods.

Robust designs also provide a framework for evaluation of temporary emigration, or the probability that an individual is unavailable for capture during the sampling occasion (Kendall et al. 1997). Unavailability for sampling is an important consideration in cave systems, as cracks, fissures, and other small human inaccessible places all limit the ability of sampling technique to adequately expose all individuals to sampling efforts. The availability to be captured must be incorporated into our estimates of capture probabilities and hence other population parameters. For this, robust design methods are recommended. We also see future applications for parameter estimation combining robust design models under a multi-state framework (Schwarz 2005). Under a multi-state framework, interest is in estimating the transition probability between various states (e.g., breeding/non-breeding, movements between locations) while robust designs could be used to estimate abundance and demographic parameters associated with the temporal frame during which the above states occur.

One final topic relates to use of presence-absence surveys (Mackenzie et al. 2006). We suggest that estimation of occupancy (probability that a species is present in a location) has some relevance to surveys for subterranean species distributed in cave systems across a landscape. Estimates of species richness are often tied to the number

of caves surveyed (Schneider and Cluver 2004, Culver et al. 2004) and methods that use presence/absence of species at different locations could be used to determine the likelihood that the species is present at locations where it was not detected (Nichols et al. 1998). An example application of presence/absence surveys at the macro-level could evaluate the distribution of a species by surveying caves across a region (Culver et al. 2004), or, at the micro-level one could survey specific habitats (pools, runs, etc.) within a cave system and evaluate covariates (distance from mouth, temperature) which could influence species presence. The primary benefit from application of presence/absence approaches is that under a viable sampling design, they allow estimation of the likelihood a species is present, even if undetected, and allow for incorporation of potential covariates to determine what information best predicts presence to aid in future sampling plans.

We have provided some general thoughts on potential designs which could be applied in cave studies that could use capture-mark-recapture/resight information to estimate population parameters. Obviously, there is a host of literature on population parameter estimation methods available and we have only scratched the surface of potential approaches which could be applicable to subterranean systems. We suggest interested readers see works by Otis et al (1978), Kendall et al. (1995), Thompson et al. (1998), Williams et al. (2002), Thompson (2004) and Amstrup et al. (2005).

References

- AMSTRUP, S.C., T.L. MCDONALD & B.F.J. MANLY (2005) *Handbook of capture-recapture analysis*. Princeton University Press, Princeton, New Jersey, p. 313.
- BARR, TC JR. & J.R. HOLSINGER (1969) Speciation in cave faunas. *Annual Review of Ecology and Systematics* **16**, 313–337.
- BENEDETTI-CECCHIE, L., L. AIROLDI, M. ABBIATI, & F. CINELLI (1996) Estimating the abundance of benthic invertebrates: a comparison of procedures and variability between observers. *Marine Ecology Progress Series* **138**, 93–101.
- CAM, E., J.D. NICHOLS, J.R. SAUER, & J.E. HINES (2002) On the estimation of species richness based on the accumulation of previously unrecorded species. *Ecography* **25**, 102–108.

- CRUNKILTON, R. (1984) Subterranean contamination of Meramec Spring by ammonium nitrate and urea fertilizer and its implication on rare cave biota. *Proceedings of the 1984 National Cave Management Symposium – Journal of the Missouri Speleological Society* **25**, 1–4.
- CULVER, D.C., M.C. CHRISTMAN, B. SKET, & P. TRONTELJ (2004) Sampling adequacy in an extreme environment: species richness patterns in Slovenian caves. *Biodiversity and Conservation* **13**, 1209–1229.
- CHAO, A., & R.M. HUGGINS (2005) Modern closed-population capture-recapture models. Chap. 4 in *Handbook of capture-recapture analysis*, Amstrup, S. C., T. L. McDonald and B. F. J. manly (Eds.). Princeton University Press, Princeton, p. 59–87.
- FENOLIO, D.B., G.O. GRAENING, & J.F. STOUT (2005) Seasonal movement pattern of pickerel frogs (*Rana palustris*) in an Ozark cave and ecological implications supported by stable isotope evidence. *The Southwestern Naturalist* **50**(3), 385–389.
- FENOLIO, D.B., G.O. GRAENING, B.A. COLLIER, & J.F. STOUT (2006) Coprophagy in a cave-adapted salamander; the importance of bat guano examined through stable isotope and nutritional analyses. *Proceedings of the Royal Society – B* **273**, 439–443.
- KENDALL, W.L., K.H. POLLOCK, & C. BROWNIE (1995) A likelihood based approach to capture-recapture estimation for demographic parameters under the robust design. *Biometrics* **51**, 293–308.
- KENDALL, W.L., J.D. NICHOLS, & J.E. HINES (1997) Estimating temporary emigration using capture-recapture data with Pollock's robust design. *Ecology* **78**, 563–578.
- MACKENZIE, D.I., J.D. NICHOLS, J.A. ROYLE, K.H. POLLOCK, L.L. BAILEY, & J.E. HINES (2006) *Occupancy estimation and modeling: inferring patterns and dynamics of species occurrence*. Academic Press, San Diego, California, p. 324.
- NICHOLS, J.D., T. BOULINIER, J.E. HINES, K.H. POLLOCK, & J.R. SAUER (1998) Inference methods for spatial variation in species richness and community composition when not all species are detected. *Conservation Biology* **12**, 1390–1398.
- NICHOLS, J.D., J.E. HINES, J.R. SAUER, F.W. FALLON, J.E. FALLON, & P.J. HEGLUND (2000) A double-observer approach for estimating detection probability and abundance from point counts. *Auk* **117**, 393–408.
- NICHOLS, J.D., J.E. HINES, J.D. LEBRETON, & R. PRADEL (2000) The relative contribution of demographic components to population growth: a direct estimation approach based on reverse time capture recapture. *Ecology* **81**, 3362–3376.
- NICHOLS, J.D. (2005) Modern open-population capture-recapture models. Chap. 5 in *Handbook of capture-recapture analysis*, Amstrup, S. C., T. L. McDonald & B. F. J. manly (Eds.). Princeton University Press, Princeton, p. 88–123.
- OTIS, D.L., K.P. BURNHAM, G.C. WHITE, & D.R. ANDERSON (1978) Statistical inference from capture data on closed populations. *Wildlife Monographs* **62**, 1–135.
- POULSON, T.L. & D.C. CULVER (1969) Diversity In terrestrial cave communities. *Ecology* **50**(1), 153–158.
- SCHNEIDER, K., & D.C. CULVER (2004) Estimating subterranean species richness using intensive sampling and rarefaction curves in a high density cave region in West Virginia. *Journal of Cave and Cave Studies* **66**, 39–45.
- SCHWARTZ, J.S. (1976) A biological study of Cathedral Cave, Crawford County, Missouri. *Journal of the Missouri Speleological Society* **16**, 1–21.
- SCHWARZ, C.J (2005) Chap. 8 in *Handbook of capture-recapture analysis*, Amstrup, S. C., T. L. McDonald and B. F. J. manly (Eds.). Princeton University Press, Princeton, p. 88–123.
- THOMAS, L. (1996) Monitoring long-term population change: why are there so many analysis methods? *Ecology* **77**, 49–58
- THOMPSON, W.L., G.C. WHITE, & C. GOWAN (1998) *Monitoring vertebrate populations*. Academic Press, San Diego, California, p. 365.

WEAVER, H.D. (1987) The commercial caves of Camden County, Missouri. *Journal of the Missouri Speleological Society* **27**, 91–132.

YOCCOZ, N.G., J.D. NICHOLS, & T. BOULINIER (2001) Monitoring of biological diversity in space and time. *Trends in Ecology and Evolution* **16**, 446–453.

RECENT FINDINGS ABOUT THE BIOLOGY, ECOLOGY, AND SYSTEMATICS OF THE GROTTO SALAMANDER, *EURYCEA SPELAEA*

DANTÉ FENOLIO¹, RONALD BONETT²

¹Atlanta Botanical Garden, Center for Conservation, 1345 Piedmont Ave., Atlanta, GA 30309

²University of Tulsa, Department of Biological Sciences, 800 S. Tucker Dr., Tulsa, OK 74104

The Grotto Salamander, *Eurycea spelaea* (= *Typhlotriton spelaeus*), has been known to science for over 100 years yet many aspects of its natural history and ecology remain unknown. Basic information on reproductive behavior, egg deposition sites, and population sizes have not been reported. However, a long-term study (over eight years) of one population in Oklahoma's Ozark Mountains has produced interesting findings. For example, with direct observations supported by stable isotope analysis, it has been demonstrated that larval *E. spelaea* feed directly on fresh bat guano. Further, the movements of salamanders in the study cave suggest that individuals congregate in the main caverns of subterranean systems, where colonial bats roost when the bats utilize the caves. When the bats depart in the fall, the salamanders appear to disperse from the larger bat-inhabited rooms. A population size of 264 to 367 individuals was estimated for the population inhabiting the study site using the Schnabel estimator (CI = 95%). Analysis of pigmentation in larval salamanders suggests that a significant portion of the larval population leave the subterranean system for a portion of the larval period; however, many larvae disperse from subterranean habitats. Additionally, mitochondrial DNA sequencing suggests there are several genetically divergent clades in the Ozarks that correspond to subdivisions of the Ozark Plateau, thus "*Eurycea spelaea*" may be a complex containing multiple species.

1. Introduction

A review of the literature for *Eurycea spelaea* demonstrates that despite its description over 100 years ago (Stejneger, 1892), much regarding its basic ecology remains unknown. Here, we review the biological literature for this species in five distinct categories, where information has been garnered in the past several years: phylogenetics and taxonomy, intra and interspecific species interactions, diet/feeding behavior/trophic interactions, population size, and habitat use.

2. Phylogenetics and Taxonomy

Recently, grotto salamanders were found to be phylogenetically nested within the genus *Eurycea* (family Plethodontidae) and, therefore, the genus *Typhlotriton* was synonymized with *Eurycea* (Bonett and Chippindale, 2004). Issues relating to alleged pedomorphic populations and separate arguments for populations with supposed distinct morphological characters have produced a somewhat confusing history for this species. Both *Typhlotriton nereus* (Bishop, 1944) and *T. braggi* (Smith, 1968) were described as distinct species for these respective reasons. However, neither *T. nereus* or *T. braggi* withstood rigorous morphological analysis, and have since been synonymized with *Typhlotriton spelaeus* (i.e., *E. spelaea*; Brandon, 1965, 1966; Brandon and Black, 1970). Mitochondrial DNA sequences from several populations of grotto salamander from across their distribution indicate multiple divergent

genetic lineages that each may represent distinct species (Bonett and Chippindale, 2004). Therefore, previously synonymized taxa, *E. nereus* and *E. braggi*, might need to be resurrected. More detailed geographic genetic sampling is currently underway to address these taxonomic issues as well as to test for putative isolating mechanisms that might have promoted lineage diversification of grotto salamanders (Bonett and colleagues, unpublished results).

3. Intra and Interspecific Interactions

Little information has been reported on intraspecific interactions among grotto salamanders. Larval aggression and cannibalism were described by Smith (1959) and Rudolph (1978, 1980). An understanding of interspecific interactions is also scant, but grotto salamanders are known to be broadly sympatric (and syntopic) with three congeners: *E. lucifuga*, *E. longicauda melanopleura*, and *E. tynerensis* (Rudolph, 1978, 1980; Petranksa, 1998; Fenolio and Trauth, 2005). Rudolph (1978, 1980) argued that larval grotto salamanders inhabit the most ideal spring habitat for a series of reasons: closest to groundwater discharge, with fewer fish predators, with cooler water temperatures, and with less risk for the water source drying. Rudolph provided evidence that larval *E. spelaea* displace the larvae of other sympatric *Eurycea* species to less optimal habitat through aggressive behavior. He noted that larval *E. spelaea* were sensitive to flood conditions and would disappear from

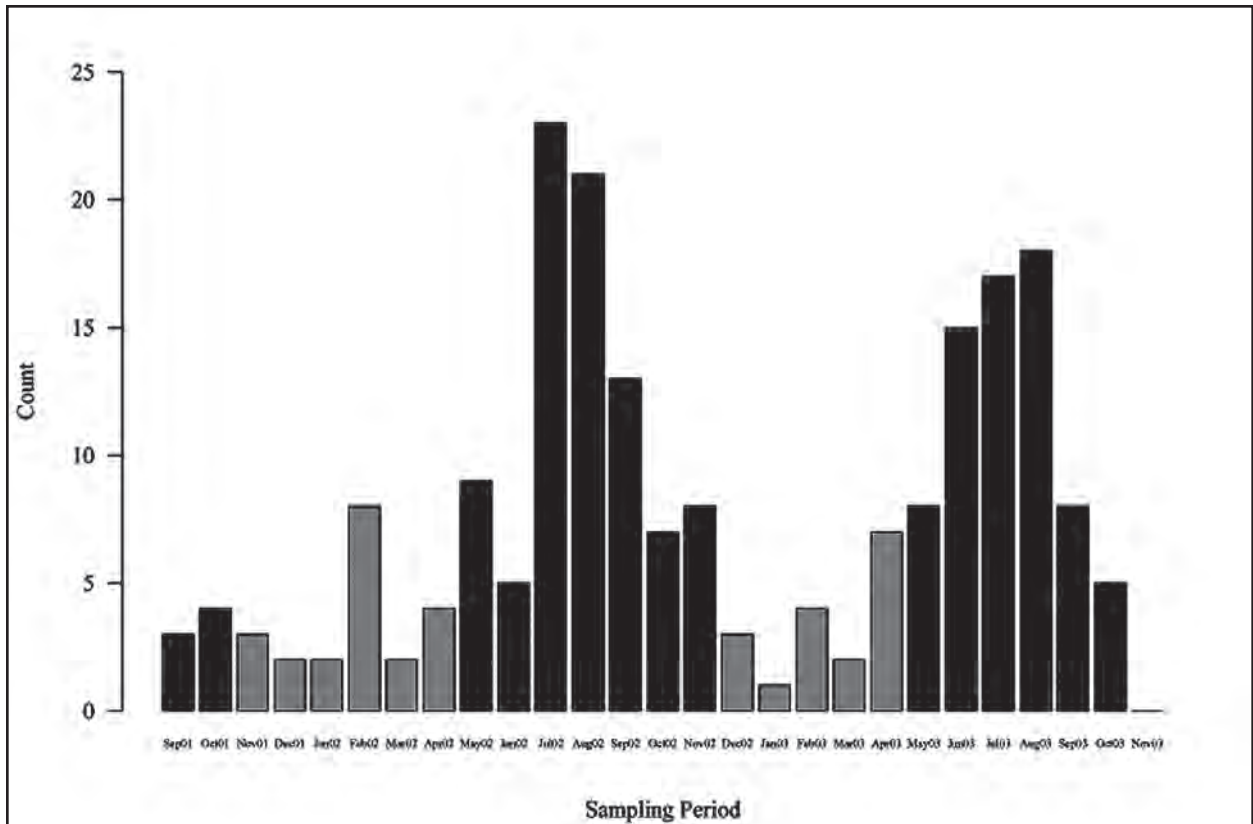

Figure 1: Captures of *Eurycea spelaea* by month in January-Stansberry Cave, Delaware County, Oklahoma, between September 2001 and October 2003. The black bars of the figure represent the period of time in which colonial bats, *Myotis grisescens*, used the cave.

optimal habitat after floods, whereafter, larval *E. spelaea* were replaced by the other *Eurycea* larvae until a new cohort of larval *E. spelaea* emerged to start the cycle again.

Fenolio et al. (2005a) focused on salamander interactions with the colonial bat *Myotis grisescens*, noting that salamander densities in the main caverns of the study cave increased when colonial bats inhabited the cave as a maternity site (Figure 1). Rudolph (1978, 1980) discussed potential predation by predatory fishes. Petranka (1998) and Fenolio (2003) discussed potential predation by crayfish. Fenolio and Trauth (2005) covered potential predation by raccoons, *Procyon lotor*, and the ranid frogs *Rana palustris* and *R. clamitans*. Fenolio et al. (2005b) found no evidence for seasonally cave-dwelling *R. palustris* as predators of *E. spelaea* via stable isotope and stomach content analyses. Greene (1961) noted the defensive behavior of tail waving in adults and Brodie (1983) documented tail waving and defensive secretions. Fenolio and Trauth (2005) discussed the defensive behavior of adults dropping off cave walls into the water upon approach. Lists of syntopic subterranean wildlife have been included in a variety of papers (e.g., Chase and Blair, 1937; Hendricks and Kezer, 1958; Brandon,

1971a, 1971b; Fenolio, 2003; Fenolio et al., 2005a, 2005b; Graening and Fenolio, 2005; Graening et al., 2006).

4. Feeding Behavior/Diet/Trophic Interactions

Schwartz (1976) listed *E. spelaea* as a top predator in one study cave ecosystem. Smith (1948), Mohr (1950), Brandon (1971a), and Fenolio and Trauth (2005) discussed both aquatic and terrestrial feeding by adults. Black (1973) and Fenolio and Trauth (2005) reported adults hunting for food on guano piles. All life stages of these salamanders consume invertebrates (Dodd, 1980; Petranka, 1998; Fenolio, 2003). Food items have been listed by Smith (1948; isopods and snails), Rudolph (1978, 1980; salamander larvae), Brandon, (1971a; helemozid flies, dipteran larvae, snail shells, mosquito larvae, beetles, and centipedes), Fenolio (2003), Fenolio and Trauth (2005) and Fenolio et al. (2005a) all report *Gammarus*, and Fenolio and Trauth (2005; web worms, larvae of the dipteran *Macrocera nobilis*). A novel behavior in any caudate, the larvae of *E. spelaea* directly consume fresh guano of the colonial bat *Myotis grisescens*. In the study that first described this behavior, *Myotis grisescens* guano was also analyzed and demonstrated to contain considerable nutritional value (Fenolio et al., 2005a).

5. Population Size

A two-year mark/recapture study of a population in Oklahoma produced an estimate of 264–367 individuals using the Schnabel estimator (CI = 95%) (Fenolio and colleagues, unpublished results). Because cave length, food resources, and available habitat vary, we feel population sizes in this species may be dramatically different between subterranean systems. Other population data include numbers of grotto salamanders collected or marked across two-year study periods, but neither study produced a population estimate (Pyle, 1964; Brandon, 1971b).

6. Larval Pigmentation and Habitat Use

Many authors have noted that larval *E. spelaea* commonly live in waterways inside and outside of caves (e.g., Mittleman, 1950; Conant, 1958; Vandel, 1965; Pyle, 1964; Brandon, 1971b; Rudolph, 1978, 1980; Fenolio, 2003). Further, according to two studies, exposure to light results in the development of dermal pigments in larval *E. spelaea* (Noble and Pope, 1928; Pyle, 1964). If larval pigmentation does correlate with exposure to light and larvae are regularly moving into and out of a given subterranean system, Fenolio and colleagues (unpublished results) hypothesize that (1) the greatest numbers of larvae should be encountered near the mouth of their study system and (2) that a portion of the larval *E. spelaea* in their study population should exhibit some degree of pigmentation. In fact, these findings suggest a structuring of larval position does exist where larval densities were highest within the first 110 m (relative to the cave mouth) of subterranean habitat. Further, the findings confirm that the majority of larvae in the study population (>60%) have developed dermal pigmentation.

7. Conclusions

Many aspects of the natural history, population ecology, and biogeography of the grotto salamander remain unclear. However, modern genetic techniques and long term studies are gradually filling in the gaps. Future studies should focus on habitat use in the larval stage and employ relevant genetic analyses to determine whether surface living larvae provide connectivity between subterranean adult populations, shifting isolated populations to a metapopulation scenario. Further, efforts should be made to determine the microhabitats used for egg deposition so that the life cycle is better understood.

References

BONETT, R.M. & P.T. CHIPPINDALE 2004. Speciation, phylogeography and evolution of life history and morphology in plethodontid salamanders of the

Eurycea multiplicata complex. *Molecular Ecology* 13, 1189–1203.

BISHOP, S.C. (1944) A new neotenic plethodont salamander with notes on related species. *Copeia* 1944(1), 1–4.

BLACK, J.H. (1973) Checklist of the cave life of Oklahoma. I. Amphibia. *Proceedings of the Oklahoma Academy of Sciences* 53, 33–37.

BRANDON, R.A. (1965) *Typhlotriton*. *Catalogue of American Amphibians and Reptiles*: 20.1–20.2. American Society of Ichthyologists and Herpetologists, Maryland.

BRANDON, R.A. (1966) A reevaluation of the status of the salamander, *Typhlotriton nereus*, Bishop. *Copeia* 1966(3), 555–561.

BRANDON, R.A. (1971a) North American troglobitic salamanders: some aspects of modification in cave habitats, with special reference to *Gyrinophilus palleucus*. *National Speleological Society Bulletin* 33(1), 1–21.

BRANDON, R.A. (1971b) Correlation of seasonal abundance with feeding and reproductive activity in the grotto salamander (*Typhlotriton spelaeus*). *American Midland Naturalist* 86, 93–100.

BRANDON, R.A. and J.H. BLACK (1970) The taxonomic status of *Typhlotriton braggi* (Caudata, Plethodontidae). *Copeia* 1970(2), 388–391.

BRODIE, E.D. (1983) Antipredator adaptations of salamanders: evolution and convergence among terrestrial species. From *Plant, Animal, and Microbial Adaptations to Terrestrial Environment*. Pp. 109–133. Margaris, N.S., M. Arianooutsou-Faraggitaki, & R.J. Reiter (eds.). Plenum Publishing Co., New York.

CHASE, H.D. & A.P. BLAIR (1937) Two new blind isopods from northeastern Oklahoma. *American Midland Naturalist* 18(2), 220–224.

CONANT, R. (1958) *A Field Guide to Reptiles and Amphibians of the United States and Canada East of the 100th Meridian*. Houghton Mifflin Co., Boston, Massachusetts. 366 pp.

DODD, C.K. (1980) Notes on the feeding behavior of

- the Oklahoma salamander, *Eurycea tynnerensis* (Plethodontidae). *The Southwestern Naturalist* 25, 111–113.
- FENOLIO, D.B. (2003) Ecology of the Grotto Salamander, *Typhlotriton spelaeus*. Unpublished Masters Thesis. University of Oklahoma, Department of Zoology, Norman, OK. 94 pp.
- FENOLIO, D.B., G.O. GRAENING, and J.F. STOUT. (2005a) Seasonal movement pattern of pickerel frogs (*Rana palustris*) in an Ozark cave and ecological implications supported by stable isotope evidence. *The Southwestern Naturalist* 50(3), 385–389.
- FENOLIO, D.B., G.O. GRAENING, B.A. COLLIER, and J.F. STOUT. (2005b) Coprophagy in a cave-adapted salamander; the importance of bat guano examined through nutritional and stable isotope analyses. *Proceedings of the Royal Society – B*, 273(1585), 439–443.
- FENOLIO, D.B. and S.E. TRAUTH (2005) *Typhlotriton (Eurycea) spelaeus* Stejneger, 1893:863–866. Species account within *Amphibian Declines, The Conservation Status of United States Species*, M. Lannoo (Ed.). University of California Press, Berkeley. 1094 pp.
- GRAENING, G.O. and D.B. FENOLIO (2005) Status update of the Delaware County Cave Crayfish, *Cambarus subterraneus* (Decapoda: Cambaridae). *Proceedings of the Oklahoma Academy of Sciences* 85, 85–89.
- GRAENING, G.O., J.B. KOPPELMAN, B.K. WAGONER, M.E. SLAY, and C.L. BRICKEY (2006) Range extension and status update of the endangered hell creek cave crayfish, *Cambarus zophonastes* (Decapoda: Cambaridae). *The Southwestern Naturalist* 51(3), 392–396.
- GREENE, H. (1961) Additional instances of tail waiving in salamanders. *The Bulletin of the Philadelphia Herpetological Society* 9(4), 19.
- HENDRICKS, L.J. and J. KEZER (1958) An unusual population of a blind cave salamander and its fluctuation during one year. *Herpetologica* 14, 41–43.
- MITTLEMAN, M.B. (1950) Cavern-dwelling salamanders of the Ozark Plateau. *Bulletin of the National Speleological Society* 12, 12–15.
- MOHR, C.E. (1950) Ozark cave life. *National Speleological Association Bulletin* 12, 3–11.
- NOBLE, G.K. and S.H. POPE (1928) The effect of light on the eyes, pigmentation, and behavior of the cave salamander, *Typhlotriton*. *Anatomical Record* 41, 21.
- PETRANKA, J.W. (1998) *Salamanders of the United States and Canada*. Smithsonian Institution Press, 587 pp.
- PYLE, W.E. (1964) A population study of the Ozark blind cave salamander, *Typhlotriton spelaeus*. Unpublished thesis, Central Missouri State College, Warrensburg, Missouri. 47 pp.
- RUDOLPH, D.C. (1978) Aspects of the larval ecology of five plethodontid salamanders of the western Ozarks. *American Midland Naturalist* 100, 141–159.
- RUDOLPH, D.C. (1980) Competition among five species of cave associated salamanders (Family Plethodontidae). Unpublished Ph.D dissertation. Texas Tech University, Lubbock, Texas. 74 pp.
- SMITH, P.W. (1948) Food habits of cave dwelling amphibians. *Herpetologica* 4, 205–208.
- SMITH, C.C. (1959) Notes on the salamanders of Arkansas #1, life history of a neotenic stream dwelling form. *Proceedings of the Arkansas Academy of Sciences*, 67–74.
- SMITH, C.C. (1968) A new *Typhlotriton* from Arkansas (Amphibia: Caudata). *The Wasmann Journal of Biology* 26, 155–159.
- SCHWARTZ, J.S. (1976) A biological study of Cathedral Cave, Crawford County, Missouri. *Journal of the Missouri Speleological Society* 16(4), 1–21.
- STEJNEGER, L. (1892) Preliminary description of a new genus and species of blind cave salamander from North America. *Proceedings of the National Museum* 15(894), 115–117.
- VANDEL, A. (1965) *Biospeleology. The Biology of Cavernicolous Animals*. Pergamon Press, New York. 524 pp.

SALAMANDERS OF THE GENUS *EURYCEA* AT CAMP BULLIS, BEXAR COUNTY, TEXAS

KRISTA MCDERMID¹, ANDREW GLUESENKAMP²

¹Zara Environmental, LLC, 118 W. Goforth Road, Buda, Texas 78610 USA

²Texas Memorial Museum, University of Texas, Austin, Texas 78712 USA

At least three taxonomically distinct groups of salamanders in the genus *Eurycea* are represented in collections that we made from caves and ephemeral springs on Camp Bullis, a military reservation in central Texas. We have collected a total of 69 *Eurycea* salamanders for phylogenetic research from 14 sites on Camp Bullis since we began monitoring populations on the base in 2003. We capture them by hand with an aquarium net or by using a variety of trapping methods. When a cave known to contain salamanders was found to be dry during a monitoring trip, a bottle trap was set in a location that would be submerged when the water level next rose. Ephemeral springs were surveyed by searching saturated areas around spring outflow and by netting spring flow. Habitat parameters for Camp Bullis *Eurycea* have not been strictly defined. In general, we observed *Eurycea* in caves that had low flowing water that averaged 20.6°C (range = 19.5° – 24° C). Salamanders inhabit cave pools and streams between 1 cm and 2.5 m deep, mesocaverns (humanly unenterable voids that are contiguous with cave passage), and springs. We collected *Eurycea neotenes* from nine sites on base, *Eurycea latitans* from five sites on base, and *Eurycea sp.* from two sites that appear to be isolated from the other localities. Individuals collected from these sites are morphologically similar to *E. neotenes* and *E. latitans*, but preliminary genetic data suggest they are an isolated population. We collected *E. neotenes* from two sites where we also made collections of *E. latitans*. The presence of multiple species of *Eurycea* at the same site suggests a complex evolutionary history. Studying *Eurycea* populations in caves and springs presents interesting challenges in terms of management and conservation. Populations are not accessible when the water table is at normal levels, thus monitoring opportunities are rare. Detecting population trends using infrequent monitoring data could take too long relative to the rapidly growing groundwater impacts (e.g. drawdown, contamination) from urban sprawl around the nearby city of San Antonio.

1. Introduction

Camp Bullis military reservation is located in central Texas, on the border of Bexar and Comal counties. The southernmost third of the base is geologically classified as the Edwards Aquifer and the northernmost two thirds of the base lies over the Trinity Aquifer. The distribution of species of *Eurycea* salamanders that occur on base loosely correlates with these hydrogeologic boundaries (Bendik, 2006). Speciation in subterranean populations occurs through vicariance (populations becoming genetically isolated because of the formation of geographic boundaries) or through multiple colonization events. Similar selective pressures in underground environments result in the evolution of near identical morphologies. Convergent evolution and blurring of biogeographical boundaries makes morphological analysis of taxonomic groups all but irrelevant in subterranean species (Sweet, 1984).

Central Texas *Eurycea* are paedomorphic, retaining their external gills even after reproductive maturity, and their distribution is largely associated with spring outflows or caves containing permanent water. Conduits, creeks and

other features connect caves and springs throughout the aquifer, allowing subterranean aquatic fauna to travel, survive, and reproduce underground for extended periods of time. Varied surface sampling conditions presents a special set of challenges to studying these organisms and extreme convergence between the species makes morphological analysis an unreliable method of determining species boundaries.

Eurycea collected from Camp Bullis have a complicated taxonomic history. The Texas Salamander, *E. neotenes*, was thought to be widespread throughout central Texas (Sweet, 1978) until molecular evidence led to a re-evaluation by Chippendale et al. (2000), who described the range as being restricted to springs in northwestern Bexar County. Later work extended the range of this species to include parts of Comal County. There were four species of *Eurycea* recognized on Camp Bullis (*E. neotenes*, *E. pterophila*, *E. tridentifera*, and *E. latitans*) until Bendik (2006) used molecular techniques to determine that the Cascade Caverns Salamander, *E. latitans*, was conspecific with *E. pterophila* and *E. tridentifera*. The current known range of

E. latitans extends through the western portion of Comal County, the southern portion of Kendall County, slightly into the easternmost portion of Bandera County and the northern portion of Bexar County, including the northern quarter of Camp Bullis. We currently recognize two distinct species on base, *E. neotenes* and *E. latitans*, with a third unnamed but apparently genetically distinct group occurring in ephemeral springs on the southern area of the base.

The presence of *Eurycea* salamanders was first recorded on the base in 1996 (Veni, 1998). Veni (1998) reported that *E. neotenes* was found in up to three caves on base. A *Eurycea* biomonitoring program was implemented in 2003. Eight sites on base are monitored for the presence of *Eurycea* salamanders three times per year. Periodic monitoring also occurs at many other sites on base that contain habitat considered appropriate for *Eurycea*, but this monitoring occurs only when project specifications allow. Habitat parameters for Camp Bullis *Eurycea* have not been strictly defined, as studies were designed to answer phylogenetic questions and management programs were funded only at the level to ensure continued monitoring for species persistence. Anecdotal habitat information is provided below.

2. Methods

Our *Eurycea* biomonitoring protocols dictate that we count individuals present, measure water level and clarity, and count other aquatic taxa. It should be noted that, while we monitor populations every year, we only collect specimens when there is a need for genetic material. Specimens collected for phylogenetic analysis are transferred to the lab of Paul Chippindale at The University of Texas-Arlington.

Spring populations can only be observed and sampled when springs are flowing, usually during a high water level event such as the intense rains that occurred over central Texas in 2007. Flowing springs are sampled by placing an aquarium net or a paint strainer over the spring orifice such that most of the spring flow is forced through the net, or by stuffing the orifice with strips of cotton, such as a mop head. Sampling structures are secured with wire frames or with rocks to hold them in place. The nets and "mop traps" are checked at least weekly for aquatic fauna. Organisms such as salamanders or large arthropods are hand-picked, and smaller invertebrates are collected by passing the trap under multiple rinses over a fine mesh straining device.

Cave populations are sampled when the cave is enterable (meaning that the cave is not completely underwater and that the air is breathable) or when water can be easily

reached (i.e. when the cave is flooded). If water is not accessible from the surface, cave monitoring involves entering the habitat and traveling through the cave until the sump (or surface water) is reached. At the sump, we record habitat data including water level, water temperature, water depth and clarity. Clarity is recorded by using a weighted black and white secchi disk that is lowered into the water column until it is no longer possible to discern the black and white sections. Salamander observations are recorded, along with the presence of any other visible aquatic fauna.

During monitoring projects that involve collection, we capture salamanders by hand using a small aquarium net or a larger net, such as a pool net, on a long handle. Collection sometimes involves either crawling or swimming through the sump in pursuit of the animals. We also practice "passive capture" techniques, which involve placing a bottle trap in the sump. Bottle traps have an inverted funnel-shaped opening that allows salamanders to enter the bottle but makes escape difficult, and ventilation openings that allow water and gas exchange with the environment. Bottle traps are often baited with commercial dry dog food or other readily available bait, such as the body of a cave cricket.

Ephemeral conditions have occasionally made it necessary to set up passive sampling when no water is present at a site. Caves that are dry at the time of sampling, but are known to have salamander habitat when water levels are high, are sampled by placing a bottle trap such that it will be submerged when the water level rises. Bottle traps are also occasionally used to sample large spring orifices by securing them with string so that they catch the spring flow.

3. Results

We have collected 69 individuals of spring and cave dwelling *Eurycea* from six springs and eight caves on base since 2003, using a variety of capture techniques including hand collecting, bottle trapping and netting spring flow.

Eurycea latitans was the only species of *Eurycea* salamander that we collected at three caves in the northern part of the base and probably the only species at three additional localities. These localities include one on base and two immediately adjacent to the base, where salamanders have been observed but not verified through the collection of vouchers. These caves are located in the northern section of the Edwards Aquifer recharge zone within the lower member of the Glen Rose formation. Two of the caves, one on base and one off base, are probably hydrologically connected (Zara, 2008 and George Veni and Associates, 1993-2007).

We have collected *E. latitans* from caves up to 24 m deep and from 47 to 104 m in length. The aquatic habitat differs somewhat between caves, from intermittent streams to extensive water-filled passages, with water temperature typically averaging 20.6° C. On one occasion, two individuals were collected from an ephemeral pool above the normal sump level during a high water level event. At another location, *Eurycea latitans* was collected from a shallow muddy pool and from a deep, still pool at a third location. A total of eight salamanders were collected from these three caves.

Nine salamanders were collected from four spring sites and two caves that yielded *Eurycea neotenes* but not *E. latitans*. The springs were the subjects of intensive sampling during high water events in 2007, when the specimens were collected. One of the springs discharges from a fault at the base of a 7 m high cliff at a rate of up to 24 liters per minute. Two others seep from the base of a bluff at varying rates ranging from 0.5 to 12 liters per minute. These two springs may be intermittent but there is a dam downstream suggesting that they may have flowed constantly in the past. One of the caves from where *E. neotenes* has been collected was discovered after the excavation of two side-by-side springs, and the other cave is the largest sinkhole on Camp Bullis. It has 140 m of lower level meandering stream passage with water from 0.2 to 0.5 m deep.

In addition to the sites discussed above, we collected genetically variable *Eurycea* from three caves. The genes of these individuals show evidence of introgression between *E. latitans* and *E. neotenes*. These crosses produce fertile hybrid offspring that can mate and backcross with the parental generation. Individuals of both species were collected in at least two of the caves. These “introgression caves” tend to have permanent water flowing through them and appear to be hydrologically connected. A total of 41 salamanders have been collected from these three sites, with up to 20 individuals coming from a single cave.

We have collected 11 *Eurycea* sp. from a set of ephemeral springs in a southern portion of Camp Bullis known as Maneuver Area 9. One of these springs flows from a 0.1 m high and wide conduit along a bedding plane and leaks water into the bed of a stream channel. The other spring is located in the creek bed and discharges water strongly enough to boil up the gravel that otherwise covers it. The *Eurycea* that have been collected from these two springs are genetically isolated from both *E. latitans* and *E. neotenes* (Zara, 2008 and George Veni and Associates, 1993-2007). The springs in Maneuver Area 9 flow only during high

water events and were sampled opportunistically during the summer of 2007 using a combination of nets placed over the spring outflow and bottle traps.

4. Discussion

The high numbers of *Eurycea* salamanders encountered on base (as many as 20 from one cave) indicate that Camp Bullis and the surrounding area harbor important habitat for the salamander. Much of the area adjacent to the military base has been urbanized and is not intended for species conservation. The presence of as many as three species of *Eurycea* on base and the presence of more than one species at some sites suggests a complex history of vicariance and invasion events in which the hydrogeologic evolution of the landscape has affected the distribution and speciation of these organisms.

We collected individuals of both *Eurycea neotenes* and *E. latitans* from two caves. When multiple congeners exist sympatrically, there is usually some sort of niche specialization, such as a difference in microhabitat utilization, body size, or diet that prevents one from out-competing the other (Southerland, 1986). The existence of two species of *Eurycea* at the same site is interesting because they are ecologically and morphologically similar. Sympatry is interesting from an evolutionary perspective because it suggests that each species may have invaded the habitat independently, and the evidence of introgression coupled with the apparently large population size (41 specimens collected) indicates a potentially long-lived hybrid population that may prove to be persistent and genetically stable.

Fixed genetic differences in the *Eurycea* sp. found in the two springs in Maneuver Area 9 suggest that this group has been in isolation for quite some time and that they may be on their own unique evolutionary trajectory. Reproductive isolation in this population is probably a result of the isolated nature of the springs, which occur in a shallow valley and are cut off from other *Eurycea* populations by a creek. The springs only flow during high water level events, so sampling at these sites is not always possible. When the springs stop flowing, the animals retreat underground and cannot be detected using currently established methods. The genetics of this population do not indicate gene flow with other populations. This suggests that, even when the animals retreat underground, there is some hydrogeological barrier acting as an isolating mechanism.

Subterranean aquatic fauna are difficult to study because their environment is often inaccessible to researchers. The interface between the aquifer and the surface only occurs

at spring outlets, which can often only be detected when the water table is high enough to allow them to flow, and in cave sumps, which are often challenging to access and can be dangerous or impossible to access. Three different capture techniques have been used thus far during the course of our study, with varying rates of success. This illustrates the fact that a combination of sampling strategies is required to successfully sample animals that occur in such variable environments. Because spring outflows release water onto the surface or into creekbeds, the likelihood that a typically hypogean salamander would be present when a researcher is visiting the spring is fairly low. Nets placed over the outflow are most effective at sampling springs because they can be arranged so that the majority of the flow is forced through the net before flowing out, effectively straining out the organisms being washed from the spring. Another advantage of using net traps on the surface is that they are left in place for long periods of time, including overnight when hypogean organisms may be more likely to come to the surface. Capturing individuals by hand is somewhat effective in caves, but is totally reliant on the salamander being visible to the researcher. Bottle traps are the most effective method for trapping salamanders in caves because bottle traps continue to present an opportunity for capture even when the researcher is not present, and can be placed where the researcher would not necessarily be able to locate a salamander because of limited visibility.

Worldwide amphibian declines are the result of habitat destruction, including contamination, and other factors (Davidson, 2004; Blaustein and Bancroft, 2007). Urban sprawl from the city of San Antonio has effects on the aquifer by contaminating groundwater, interrupting recharge, changing recharge regimes, and drawing down the level of the aquifer. *Eurycea* are probably at greater risk from habitat loss due to groundwater withdrawals than from contamination because the contaminants are in a diluted state due to the sheer volume of groundwater in this portion of the Edwards Aquifer.

Conservation implications for sampling species at ephemeral locations are many. Difficult to detect organisms like the *Eurycea* species on Camp Bullis cannot be monitored as efficiently or as regularly as terrestrial organisms in accessible environments. The resulting opportunistic monitoring is problematic because, should population changes occur, they would likely be detected after a lag in which the environment had become inhospitable to the species, and subsequent recolonization would be unlikely. The inability to confidently track population trends leaves land managers in the dark with respect to management solutions because by

the time a problem is detected there is a high likelihood that the damage to the population is already irreparable.

References

- Bendik, N.F. 2006. Population genetics, systematics, biogeography, and evolution of the southeastern central Texas *Eurycea* clade Blepsimolge (Plethodontidae). Masters thesis, The University of Texas at Arlington. 127 p.
- BLAUSTEIN, A.R. and B.A. BANDCROFT (2007) Amphibian population declines: evolutionary considerations. *BioScience* **57**, 437–444.
- CHIPPINDALE, P.T., A.H. PRICE, J.J. WIENS, and D.M. HILLIS (2000) Phylogenetic relationships and systematic revision of central Texas hemidactyliine plethodontid salamanders. *Herpetological Monographs* **14**, 1–80.
- DAVIDSON, C (2004) Declining downwind: amphibian population declines in California and historical pesticide use. *Ecological Applications* **14**, 1892–1902.
- SOUTHERLAND, M.T. (1986) Coexistence of three congeneric salamanders: the importance of habitat and body size. *Ecology* **67**, 721–728.
- Sweet, Samuel S (1978) The evolutionary development of the Texas *Eurycea* (Amphibia: Plethodontidae). Ph.D. Dissertation, University of California, Berkeley, California, U.S.A.
- SWEET, S.S. (1984) Secondary contact and hybridization in the Texas cave salamanders *Eurycea neotenes* and *E. tridentifera*. *Copeia* **1984**, 428–441.
- Veni, G., W. R. Elliott, A. M. Scott, R. S. Toomey, III, and J. R. Reddell (1998) Hydrogeologic, biological, and archeological surveys of Lower Glen Rose caves, and continued biological monitoring of four Edwards Limestone caves, Camp Bullis, Texas. Report for Prewitt & Associates, Austin, Texas, George Veni & Associates, San Antonio, Texas, 209 p.
- Zara (2008) and George Veni and Associates (1993-2007) Hydrogeological, biological, archeological, and paleontological karst investigations, Camp Bullis, Texas. Report for Natural and Cultural Resources, Environmental Division, Fort Sam Houston, Texas, 2736 p.

SYSTEMATICS AND EVOLUTIONARY HISTORY OF SUBTERRANEAN *GYRINOPHILUS* SALAMANDERS

MATTHEW L. NIEMILLER¹, BRIAN T. MILLER², BENJAMIN M. FITZPATRICK¹

¹University of Tennessee, Department of Ecology & Evolutionary Biology, Knoxville, TN 37996 USA

²Middle Tennessee State University, Department of Biology, Murfreesboro, TN 37132 USA

The Tennessee Cave Salamander (*Gyrinophilus palleucus*) complex comprises populations of stygobitic, neotenic salamanders endemic to subterranean waters of central and east Tennessee, north Alabama, and northwest Georgia. Two species are currently recognized based on morphology, *G. palleucus* and *G. gulolineatus*, with the former comprising two subspecies, *G. p. palleucus* and *G. p. necturoides*. However, many populations are difficult to assign to any of the described taxa. The other obligate cave-dwelling congener is the West Virginia Spring Salamander (*G. subterraneus*), a metamorphosing subterranean species endemic to just a single cave in West Virginia. Our study of cave-inhabiting *Gyrinophilus* shows that the four nominal forms (*G. p. palleucus*, *G. p. necturoides*, *G. gulolineatus*, and *G. subterraneus*) arose recently, perhaps during the late Pliocene and Pleistocene, and are genealogically nested within the epigeic species, *G. porphyriticus*. Precise phylogenetic relationships are obscured by short branch lengths and discordant gene trees. However, other evidence supports independent origins for *G. palleucus*, *G. gulolineatus*, and *G. subterraneus*. Coalescent-based analysis of the distribution of haplotypes among species indicates that the process of divergence occurred in the presence of continuous or recurrent gene flow between subterranean populations and their surface-dwelling progenitor. Subterranean founder populations may have become isolated owing to extirpation of surface source populations. However, we propose that epigeic and hypogean forms evolved their distinct morphologies and life histories while experiencing repeated bouts of secondary contact and gene flow, a scenario we term the “periodic isolation” hypothesis.

1. Introduction

Gyrinophilus consists of large, semi- to permanently aquatic members of the Plethodontidae with four recognized species. Three of these are troglobitic and endemic to the Interior Low Plateau and Appalachian Valley of eastern North America. The fourth is trogliphilic, thriving in both hypogean and epigeic habitats. The Tennessee Cave Salamander (*G. palleucus*) complex comprises populations of paedomorphic salamanders in subterranean waters of middle and eastern Tennessee, northern Alabama, and northwestern Georgia (Petranka 1998; Miller and Niemiller 2008). These are large-bodied, permanently aquatic, gilled salamanders with reduced eyes, a broad head with a distinctly spatulate snout, and a long laterally-flattened tail. Two species are formally recognized within the complex: the Tennessee Cave Salamander, *G. palleucus*, and the Berry Cave Salamander, *G. gulolineatus*. The third troglobitic species is the West Virginia Spring Salamander, *G. subterraneus*, a single site endemic (General Davis Cave, Greenbrier Co., West Virginia). Unlike the *G. palleucus* complex, *G. subterraneus* undergoes metamorphosis, albeit at an exceptionally large size.

Because of their subterranean existence and reclusive nature,

the life history and ecology of cave-dwelling *Gyrinophilus* are poorly understood. Eggs have never been discovered for any taxon and little is known about reproduction in general (Petranka 1998). Because of few known localities and potential threats to several populations, the *G. palleucus* complex is state listed in Tennessee, Alabama, and Georgia, and NatureServe (2009) ranks *G. palleucus* and *G. gulolineatus* as globally imperiled (G2G3) and critically imperiled (G1Q) respectively. Although the U.S. Fish and Wildlife Service listed *G. palleucus* as a Category 2 candidate for federal listing in 1994, the species has not been included on more recent federal lists. *G. subterraneus* is state listed in West Virginia and NatureServe ranks this species as G1 (critically imperiled).

Taxonomy of *Gyrinophilus* has remained largely unchanged since Brandon's (1966) morphological investigation, with the exception of the description of *G. subterraneus* (Besharse and Holsinger 1977). However, recent studies (Osborn 2005; Niemiller et al. 2008; Niemiller et al., unpublished data) have re-examined the morphology and phylogenetic relationships of cave-dwelling *Gyrinophilus*. Here we review the systematics and evolutionary history of cave-dwelling *Gyrinophilus* in light of these new data.

Current data support the classification of *G. gulolineatus*, *G. palleucus*, and *G. subterraneus* as distinct from the surface form, *G. porphyriticus*, and suggest that the cave forms arose independently via rapid adaptive evolution in the absence of complete geographic isolation.

2. Tennessee Cave Salamander (*Gyrinophilus palleucus*)

Gyrinophilus palleucus was discovered by E.C. McCrady at Sinking Cove Cave, located on the Eastern Escarpment of the Cumberland Plateau in southern Franklin County, Tennessee (McCrady 1954). The discovery was first presented at the Tennessee Academy of Science annual meeting in December 1944 where McCrady exhibited preserved specimens and images of gilled salamanders with reduced eyes that he presumed were neotenic (McCrady 1945, 1954). McCrady delayed formal description of the species until 1954 in hopes of substantiating his presumption. H.C. Yeatman later confirmed neoteny in August 1954 when an adult male was collected from the type locality with a spermatophore protruding from its cloaca (Lazell and Brandon 1962). Though neotenic, *G. palleucus* has been induced to metamorphose in the lab (Dent and Kirby-Smith 1963; Brandon 1971), and transformed individuals have been collected in nature (reviewed in Miller and Niemiller 2008). Neotenic *G. palleucus* are similar in body form to larvae of the troglomorphic *G. porphyriticus*. However, *G. palleucus* differs from larval *G. porphyriticus* by having smaller eyes, more premaxillary, prevomerine, and pterygoid teeth, a wider head, and a more spatulate snout (McCrady 1954; Brandon 1966). Relative eye size has been the main character used to distinguish *G. palleucus* from *G. porphyriticus* morphologically (Miller and Niemiller 2008).

Two subspecies of *G. palleucus* are currently recognized. The Pale Salamander (Fig. 1a), *G. p. palleucus*, differs from the other described taxa by having pale, immaculate body pigmentation. *Gyrinophilus p. palleucus* is found in caves along the Eastern Escarpment of the Cumberland Plateau in southern Franklin and Marion Cos., Tennessee, and Jackson Co., Alabama (Miller and Niemiller 2008). All subterranean streams associated with *G. p. palleucus* localities ultimately drain into the Tennessee River. The Big Mouth Cave Salamander (Fig. 1b), *G. p. necturoides*, has nineteen trunk vertebrae, and a dark purplish-brown dorsum with heavy spotting in adults. The type locality of Big Mouth Cave is located 35 km north-northeast of the range of *G. p. palleucus* at the base of the Western Escarpment of the Cumberland Plateau in southeast Grundy Co., Tennessee. McCrady (1954) believed this population warranted subspecies

designation, which was later formally described by Lazell and Brandon (1962). The Big Mouth Cave Salamander differs from populations of *G. p. palleucus* in the Crow Creek drainage of southern Franklin County by possessing an additional trunk vertebra and a dark, spotted dorsal color pattern. No other populations resembling *G. p. necturoides* were known from the Western Escarpment of the Cumberland Plateau for more than thirty years. Recently, Miller and Niemiller (2008) reported *G. p. necturoides* from several new caves from the Western Escarpment of Cumberland Plateau, Eastern Highland Rim, and Central Basin of Tennessee.

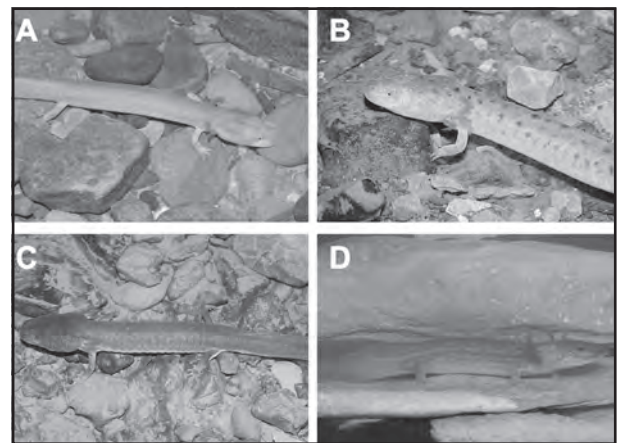

Figure 1: Obligate cave-dwelling *Gyrinophilus*: (A) Pale Salamander (*G. p. palleucus*), (B) Big Mouth Cave Salamander (*G. p. necturoides*), (C) Berry Cave Salamander (*G. gulolineatus*), and (D) West Virginia Spring Salamander (*G. subterraneus*). Photographs A, B, and C by M.L. Niemiller and D by D. Fenolio.

Outside of Tennessee, several populations of *G. palleucus* have not been assigned to subspecies in northwest Georgia (Cooper 1968; Buhlmann 2001) and northern Alabama (Brandon 1966; Cooper and Cooper 1968; Mount 1975). Previous authors have described some populations in northeast Alabama as intergrades between *G. p. necturoides* and *G. p. palleucus* (Lazell and Brandon 1962; Brandon 1966; Cooper and Cooper 1968), whereas Mount (1975) considered all populations of *G. palleucus* in Alabama as intergrades. Individuals of these populations have uniformly dark dorsal pigmentation with some individuals possessing spotting, intermediate trunk vertebrae number, and relative eye size nearer to *G. p. palleucus*. However, detailed morphological data are lacking for most populations.

3. Berry Cave Salamander (*G. gulolineatus*)

The Berry Cave Salamander (Fig. 1c) was described originally as a subspecies of *G. palleucus* by Brandon (1965), and is known from just eight caves in the Clinch

and Tennessee River watersheds of the Appalachian Valley and Ridge physiographic province in Knox, McMinn, and Roane counties of east Tennessee. *Gyrinophilus gulolineatus* differs from *G. p. palleucus* by having darker dorsal pigmentation and generally fewer trunk vertebrae (18 in 80% of *G. gulolineatus* versus 52% of *G. p. palleucus*), and from *G. p. necturoides* by possessing fewer trunk vertebrae (18 in *G. gulolineatus*, 19 in *G. p. necturoides*). Moreover, *G. gulolineatus* differs from both subspecies of *G. palleucus* by having a distinct dark stripe on the anterior half of the throat (in some populations), having a wider head with a more spatulate snout, and attaining a greater adult size (up to 136 mm SVL). Metamorphosed specimens of *G. p. palleucus* and *G. gulolineatus* differ in tooth counts, relative eye size, and division of the premaxillary bone (Simmons 1976; Brandon et al. 1986).

The taxonomic status of *G. gulolineatus* has been the subject of debate (Brandon et al. 1986; Collins 1991; Petranka 1998), although most authorities now treat the taxon as a species. Brandon et al. (1986) suggested *G. gulolineatus* be considered a separate species based on osteological evidence of transformed adults, morphological differentiation of larviform adults, and allopatry. Collins (1991, 1997) later advocated the elevation to species status. However, Redmond and Scott (1996) and Petranka (1998) treated *G. gulolineatus* as a subspecies of *G. palleucus*, a classification also currently employed by the state agencies of Tennessee.

4. West Virginia Spring Salamander (*G. subterraneus*)

The West Virginia Spring Salamander (Fig. 1d) was described by Besharse and Holsinger (1977) as a troglobitic species endemic to a single locality-General Davis Cave, in Greenbrier Co., West Virginia. Unlike *G. palleucus*, *G. subterraneus* regularly undergoes metamorphosis in nature, but at an extremely large size (>95 mm SVL, Besharse and Holsinger 1977). At the type locality, *G. subterraneus* occurs syntopically with *G. porphyriticus*. However, these species can be distinguished morphologically in several ways (Besharse and Holsinger 1977; Osbourn 2005). Larval *G. subterraneus* are larger and more robust relative to *G. porphyriticus*. In addition, larvae possess pale pinkish skin with darker reticulations and typically have two or three irregular lateral rows of pale yellow spots that are absent in larvae of *G. porphyriticus*. Moreover, *G. subterraneus* larvae have reduced eyes, wider heads, and more premaxillary and prevomerine teeth (Besharse and Holsinger 1977), but not to the extent exhibited in *G. palleucus* or *G. gulolineatus*. Metamorphosed *G. subterraneus* typically are gaunt in appearance and retain the pale reticulate coloration and

reduced eyes of larvae (Besharse and Holsinger 1977; Osbourn 2005). In addition, the premaxilla is undivided in *G. subterraneus* (also in metamorphosed *G. palleucus* and *G. gulolineatus*), but is divided in *G. porphyriticus*.

Several authors have questioned the validity of *G. subterraneus* as a species in spite of distinct morphological differences. It has been argued that *G. porphyriticus* is highly polymorphic with regards to coloration, eye size, and neoteny (Blaney and Blaney 1978) or is phenotypically plastic (Howard et al. 1984). Therefore, *G. subterraneus* represents just one of several possible phenotypes. Blaney and Blaney argued that speciation between *G. subterraneus* and *G. porphyriticus* has yet to occur and *G. subterraneus* represents a (conspecific) transitional cave form. The key argument for specific status is the co-occurrence of two distinct forms in General Davis Cave; transformed adults recognizable as *G. porphyriticus* and transformed adults with small eyes, undivided premaxilla, and distinct coloration.

5. Species Relationships

Few studies have examined the systematic relationships of taxa within *Gyrinophilus* in a phylogenetic context. Recognition of the current subspecies of *G. porphyriticus* and the obligate cave taxa is based primarily on the morphological analyses of Brandon (1966). Allozyme data (Addison Wynn, unpublished data) supports the recognition of two species within the *G. palleucus* complex: *G. palleucus* and *G. gulolineatus*. *Gyrinophilus gulolineatus* populations sampled have three unique alleles not shared with *G. palleucus*. Likewise, allozyme electrophoresis conducted by Howard et al. (1984) revealed six unique alleles in *G. subterraneus* not shared with *G. porphyriticus*. Although sample sizes were small, the authors felt *G. subterraneus* likely was a valid species and isolated from *G. porphyriticus*. Baldwin (2002) found that *G. p. palleucus* and *G. p. necturoides* form a monophyletic group sister to *G. porphyriticus* based on sequences of the ND4 and cyt *b* mtDNA genes and the RAG-1 nuclear gene.

Molecular analyses of mtDNA 12S and cyt *b* and nuclear RAG-1 genes (Niemiller et al. 2008; Niemiller et al., unpublished data) are consistent with current taxonomy describing four genetic clusters corresponding to *G. palleucus* (*palleucus* + *necturoides*), *G. gulolineatus*, *G. subterraneus*, and *G. porphyriticus*. The arguments below might not satisfy strict adherents of species definitions based on reproductive isolation or genealogical exclusivity, however, the nominal taxa are morphologically and genetically distinct (but see below for discussion on *G. subterraneus*) and are certainly valuable subjects for

studying speciation as an evolutionary process of divergence regardless of their Linnean ranking (Mallet 2008).

The data are consistent with continued recognition of the *G. gulolineatus* as a species. It maintains its distinctiveness despite geographic overlap and interbreeding with *G. porphyriticus*. Both DNA sequence data sets show clusters corresponding closely to *G. gulolineatus*. The subspecies of *G. palleucus* are morphologically distinct, but have been considered conspecific because of reported intergrades or populations that appear to include both spotted and unspotted forms. MtDNA divergence between *G. p. palleucus* and *G. p. necturoides* is low and haplotypes from the two taxa do not fall into distinct genealogical clusters (Fig. 2). RAG-1 haplotypes are more consistent with recognition of two groups (Figs. 3 and 4 in Niemiller et al. 2008). Many taxonomists have a love-hate relationship with subspecies as a Linnean rank. As evolutionary biologists, we find the designation useful as shorthand for a pattern of geographic variation suggesting incipient speciation, local adaptation, or other significant divergence. Based on the present data, we see no reason to alter the current taxonomy.

Brandon (1966) speculated that populations of *G. palleucus* inhabiting the Central Basin of Tennessee might represent an undescribed form (populations 17-18 in Niemiller et al. 2008). However, little DNA differentiation was found between these sites and other *G. palleucus* (Niemiller et al. 2008). Adjacent *G. p. necturoides* show substantial variation in dorsal coloration and degree of spotting (populations 9–13 in Niemiller et al. 2008), and populations in the Central Basin fall within that range of variation. Newly discovered populations along the Collins River in Warren County (populations 14–16 in Niemiller et al. 2008) and Duck River in Marshall and Maury counties (populations 19-20 in Niemiller et al. 2008) also show little genetic differentiation and possess coloration similar to *G. p. necturoides*. We propose extension of the range of *G. p. necturoides* to include populations in the Central Basin, and along the Duck River and Collins River.

6. Evolution of Cave Dwelling *Gyrinophilus*

A bifurcating species phylogeny was not resolved by analysis of mtDNA and *RAG-1* gene trees (Fig. 2; Fig. 3 in Niemiller et al. 2008). Genealogical discordance was manifested as shared haplotypes and more recent common ancestry of some heterospecific versus conspecific alleles. Haplotypes of *G. palleucus*, *G. gulolineatus*, and *G. subterraneus* are nested within the gene trees of *G. porphyriticus*, consistent with a scenario where each cave-adapted lineage contains a sample of ancestral Spring Salamander lineages. Our

interpretation is that the species tree is a true polytomy, representing simultaneous and independent evolution of three subterranean specialists. That is, *G. palleucus*, *G. gulolineatus*, and *G. subterraneus* each arose from a single widespread epigeal ancestor (Phase 1 speciation in Holsinger 2000). This proposition is also supported by distributional and geologic evidence. *Gyrinophilus gulolineatus* is known from caves within the East Tennessee aquifer system, which is isolated from aquifer systems to the west by a zone of faulting along the eastern escarpment of the Cumberland Plateau. This fault acts as a significant barrier for dispersal of subterranean fauna. The distributions of other stygobitic fauna, such as the Southern Cavefish (*Typhlichthys subterraneus*) and stygobitic crayfishes (*Orconectes* and *Cambarus*), exemplify this barrier; these species are abundant west of the fault but absent from the Valley and Ridge to the east. The existence of *G. gulolineatus* to the east of this subterranean barrier and *G. palleucus* to the west are consistent with the hypothesis of at least two independent invasions and adaptation to caves by ancestral *G. porphyriticus*.

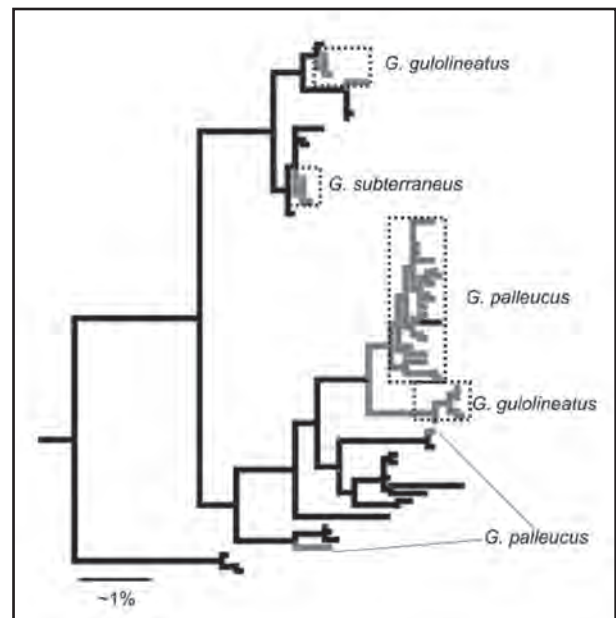

Figure 2: MtDNA sequences from obligate cave-dwelling *Gyrinophilus* (in red) are nested within the gene tree of the troglophile *G. porphyriticus* (in black) showing evidence of recent origin and multiple independent invasions. Data from nuclear *RAG-1* are similar (Niemiller et al. 2008).

Two alternative hypotheses describe the origin of subterranean species. The “climate-relict” model proposes allopatric speciation after populations of cold-adapted species become stranded in caves due to climate change (Vandel 1964; Holsinger 2000). The “adaptive-shift” model proposes parapatric speciation driven by divergent selection

between subterranean and surface habitats (Howarth 1973). Brandon (1971) postulated that the *G. palleucus* complex evolved from an epigeal, metamorphosing ancestor similar to present-day *G. porphyriticus* during the Pleistocene as fluctuating climatic conditions forced surface populations at the periphery of the species' range underground, and consequently isolating and facilitating speciation and evolution of troglomorphic characters as predicted by the climate-relict model. MtDNA and RAG-1 genealogies support the hypothesis that all three subterranean forms are recently derived from a *G. porphyriticus*-like ancestor with divergence estimates ranging from 61000 to 2.6 million years ago (Pleistocene to mid-Pliocene) (Niemiller et al. 2008). However, the data do not support the allopatric speciation scenario of the climate-relict model.

Evidence of gene flow (Niemiller et al. 2008) and the present-day ranges of the subterranean and surface forms suggest that cave-adapted *Gyrinophilus* did not diverge from their surface ancestor in strict allopatry. Under the adaptive-shift hypothesis, speciation by divergent selection results in parapatric or sympatric distributions of the incipient sister taxa (Rivera et al. 2002). Current distributions of *G. porphyriticus* and *G. palleucus* are parapatric, while *G. porphyriticus* overlaps the ranges of *G. gulolineatus* and *G. subterraneus*. However, inferring an adaptive-shift scenario based exclusively on geographic distributions is unreliable because post-speciation range shifts also may result in present-day parapatric or sympatric distributions. Alternatively, subterranean founder populations may have become temporarily isolated, but repeated bouts of recolonization by epigeal populations, possibly associated with climate change, allowed for secondary contact and gene flow, a scenario we term the "periodic isolation" hypothesis. Coalescent-based analyses (Niemiller et al. 2008) support divergence-with-gene-flow over strictly allopatric speciation with the distribution of migration events occurring over several thousand years. However, the genetic data cannot distinguish between continuous contact and alternating periods of contact and isolation. During the Pleistocene, *Gyrinophilus* are proposed to have been separated during warm periods and broadly overlapping during glacial periods when favorable cool, moist conditions would have been widespread at lower elevations (Brandon 1971). Given that interglacial periods have generally been shorter than glacial periods, and given that subterranean and surface-dwelling *Gyrinophilus* are not geographically isolated at present, periods of true isolation were likely brief relative to periods favorable to geographic overlap. Given evidence of historical and contemporary hybridization, it is clear that complete reproductive isolation did not evolve during any putative

period of geographic isolation.

Divergence in the face of continuous or episodic gene flow could be facilitated by a number of factors including assortative mating, selection against hybrids, or habitat isolation as subterranean population became more specialized and spread deeper underground (Rivera et al. 2002; Niemiller et al. 2008). In *Gyrinophilus*, access to breeding habitat may be a primary ecological advantage of subterranean colonization. However, permanent residence in caves requires special sensory, metabolic, and life history adaptations for efficient foraging and resource use (Romero and Green 2005) and these adaptations likely involve life history trade-offs. Reduction in eye size might be a pleiotropic response to selection favoring hypertrophy of other sensory systems (Jeffery 2005). Neoteny and an obligate aquatic life cycle in subterranean salamanders is probably adaptive in taking advantage of aquatic resources (Bruce 1979), while metamorphosis is favored in the small surface streams inhabited by epigeal salamanders.

Temperate cave fauna have often been viewed as isolated and relictual, originating in response to changing climatic conditions. Evidence from cave-dwelling *Gyrinophilus* and other temperate cave fauna illustrate rapid and adaptive divergence with ongoing or period bouts of gene flow; we term this scenario the "periodic isolation" hypothesis where subterranean populations are established and isolated temporarily from epigeal populations, but repeated bouts of recolonization, gene flow, and re-isolation occur, perhaps in response to climate change, during the speciation process. With increasing volumes of molecular data for cave-dwelling taxa and development of sophisticated statistical models to analyze such data, we expect discovery of more examples of divergence-with-gene-flow in cave-associated organisms.

Acknowledgements

Funding was provided by the Tennessee Wildlife Resources Agency, National Speleological Society, American Museum of Natural History, American Society of Ichthyologists and Herpetologists, Cave Research Foundation, the Dept. of Biology at Middle Tennessee State Univ., and Dept. of Ecology and Evolutionary Biology at Univ. of Tennessee-Knoxville. We thank many volunteers (too many to be listed) for assistance in the field and lab. Research was conducted under permits or authorization from the Alabama DCNR, Georgia DNR, The Nature Conservancy, Southeastern Cave Conservancy, Inc., Tennessee Wildlife Resources Agency, Virginia Cave Board, Virginia DCR, Virginia DGIF, and West Virginia DNR.

References

- Besharse JC, Holsinger JR. 1977. *Gyrinophilus subterraneus*, a new troglobitic salamander from southern West Virginia. *Copeia* 1977: 624–634.
- Blaney RM, Blaney PK. 1978. Significance of extreme variation in a cave population of the salamander, *Gyrinophilus porphyriticus*. *Proc. West Virginia Acad. Sci.* 50: 23.
- Brandon RA. 1965. A new race of the neotenic salamander *Gyrinophilus pallescens*. *Copeia* 1965: 346–352.
- Brandon RA. 1966. Systematics of the salamander genus *Gyrinophilus*. *Illinois Biol. Monogr.* 35: 1–85.
- Brandon RA. 1971. North American troglobitic salamanders: some aspects of modification in cave habitats, with special reference to *Gyrinophilus pallescens*. *Nat. Speleol. Soc. Bul.* 33: 1–21.
- Brandon RA, Jacobs J, Wynn A, Sever DM. 1986. A naturally metamorphosed Tennessee cave salamander (*Gyrinophilus pallescens*). *J. Tenn. Acad. Sci.* 61: 1–2.
- Bruce RC. 1979. Evolution of paedomorphosis in salamanders of the genus *Gyrinophilus*. *Evolution* 33: 998–1000.
- Buhlmann KA. 2001. A biological inventory of eight caves in northwestern Georgia with conservation implications. *Journal of Cave and Karst Studies* 63: 91–98.
- Collins JT. 1991. Viewpoint: a new taxonomic arrangement for some North American amphibians and reptiles. *Herpetol. Rev.* 22: 42–43.
- Collins JT. 1997. Standard common and current scientific names for North American amphibians and reptiles. 4th edition. *Soc. Study Amphibians Reptiles Herpetol. Circ. Num.* 25. 40p.
- Cooper JE. 1968. The salamander *Gyrinophilus pallescens* in Georgia, with notes on Alabama and Tennessee populations. *J. Alabama Acad. Sci.* 39: 182–185.
- Cooper JE, Cooper MR. 1968. Cave-associated herpetozoa II: salamanders of the genus *Gyrinophilus* in Alabama caves. *Nat. Speleol. Soc. Bul.* 30: 19–24.
- Dent JN, Kirby-Smith JS. 1963. Metamorphic physiology and morphology of the cave salamander, *Gyrinophilus pallescens*. *Copeia* 1963: 119–130.
- Holsinger JR. 2000. Ecological derivation, colonization, and speciation. Pp. 399–415 in H. Wilkens, D. C. Culver, and W. F. Humphreys, eds. *Ecosystems of the world*, vol. 30. Elsevier Science Ltd., Oxford.
- Howard JH, Raesly RL, Thompson EL. 1984. Management of nongame species and ecological communities. Material prepared for workshop, Univ. of Kentucky, Lexington.
- Howarth, F. G. 1973. The cavernicolous fauna of Hawaiian lava tubes. I. Introduction. *Pac. Insects* 15: 139–151.
- Jeffery WR. 2005. Adaptive evolution of eye degeneration in Mexican blind cavefish. *J Heredity* 96: 185–196.
- Lazell JD, Brandon RA. 1962. A new stygian salamander from the southern Cumberland Plateau. *Copeia* 1962: 300–306.
- Mallet J. 2008. Hybridization, ecological races, and the nature of species: empirical evidence for the ease of speciation. *Phil. Trans. Roy. Soc. B* 363: 2971–2986.
- McCrary E. 1945. Cave fauna in the Sewanee area. *J. Tenn. Acad. Sci.* 30: 325.
- McCrary E. 1954. A new species of *Gyrinophilus* (Plethodontidae) from Tennessee caves. *Copeia* 1954: 200–206.
- Miller BT, Niemiller ML. 2008. Distribution and relative abundance of Tennessee cave salamanders (*Gyrinophilus pallescens* and *Gyrinophilus gulolineatus*) with an emphasis on Tennessee populations. *Herpetol. Conserv. Bio.* 3: 1–20.
- Mount RH. 1975. The reptiles and amphibians of Alabama. Tuscaloosa (AL): The Univ. of Alabama Press. 347p.
- Niemiller ML, Fitzpatrick BM, Miller BT. 2008. Recent divergence-with-gene-flow in Tennessee cave salamanders (Plethodontidae: *Gyrinophilus*) inferred from gene genealogies. *Mol. Ecol.* 17: 2258–2275.
- Osbourn MS. 2005. The natural history, distribution, and phenotypic variation of cave-dwelling

- spring salamanders, *Gyrinophilus spp.* Cope (Plethodontidae), in West Virginia. M.Sc. Thesis, Marshall Univ., Huntington, West Virginia.
- Petranka JW. 1998. Salamanders of the United States and Canada. Washington (DC): Smithsonian Institution Press. 587p.
- Redmond WH, Scott AF. 1996. Atlas of amphibians in Tennessee. Clarksville (TN): The Center for Field Biology, Austin Peay State Univ. 94p.
- Rivera MAJ, Howarth FG, Taiti S, Roderick GK. 2002. Evolution in Hawaiian cave-adapted isopods (Oniscidea: Philosciidae): vicariant speciation or adaptive shifts? *Molecular Phylogenetics and Evolution* 25: 1–9.
- Romero A, Green SM. 2005. The end of regressive evolution: examining and interpreting the evidence from cave fishes. *J. Fish Bio.* 67: 3–32.
- Simmons DD. 1976. A naturally metamorphosed *Gyrinophilus palleucus* (Amphibia: Urodela: Plethodontidae). *J. Herpetol.* 10: 255–257.
- Vandel A. 1964. *Biospéologie. La Biologie des Animaux Cavernicoles.* Paris: Gauthier-Villars. 619 p.
- Weber A. 2000. Fish and Amphibia. Pp. 109–132 in *Subterranean Ecosystems.* Wilkens H, Culver DC, Humphreys WF (eds.). Elsevier, Amsterdam.

A SURVEY OF THE CAVE-ASSOCIATED HERPETOFAUNA OF THE EASTERN UNITED STATES WITH AN EMPHASIS ON SALAMANDERS

MATTHEW L. NIEMILLER¹, BRIAN T. MILLER²

¹University of Tennessee, Department of Ecology & Evolutionary Biology, Knoxville, TN 37996 USA

²Middle Tennessee State University, Department of Biology, Murfreesboro, TN 37132 USA

Only four salamander species are considered obligate inhabitants of caves (trogllobites) east of the Mississippi River in the United States. However, many other amphibians and reptiles use cave habitats to varying degrees for aspects of their life histories, such as reproduction, refuge, and hibernation. From 2004 to 2008, we surveyed 172 caves for amphibians and reptiles in Alabama, Georgia, Indiana, Kentucky, Tennessee, Virginia, and West Virginia using standard visual survey techniques in both aquatic and adjacent terrestrial habitats. Our survey documented 4542 occurrences of 29 species of amphibians (4081 of 18 salamanders and 461 of 11 anurans) and 11 occurrences of six reptile species. The troglophilic Cave Salamander (*Eurycea lucifuga*) represented nearly a third of all salamander occurrences and the Pickerel Frog (*Rana palustris*) represented over one half of all anuran occurrences. Three troglotitic species accounted for 1016 salamander occurrences from 34 caves: the Berry Cave Salamander (*Gyrinophilus gulolineatus*), Tennessee Cave Salamander (*G. palleucus*), and the West Virginia Spring Salamander (*G. subterraneus*). Although the occurrence of many amphibian and all reptile species in this survey can be categorized as accidental, we observed evidence of reproduction (courtship, nests, or young larvae) for several salamanders including *Eurycea cirrigera*, *E. longicauda*, *E. lucifuga*, *G. gulolineatus*, *G. palleucus*, *G. porphyriticus*, *G. subterraneus*, *Plethodon dorsalis*, and *Pseudotriton ruber*. Furthermore, recent studies have shown that several amphibian species lacking obvious adaptations to subterranean habitats are nonetheless reliant on caves to complete some aspect of their life histories. Thus, our data adds to a growing body of evidence indicating that caves are critical habitats that should be protected for proper amphibian conservation and management.

1. Introduction

The Interior Low Plateau (ILP) and Appalachian Valley (AV) karst regions represent two of the most diverse cave regions in North America. Accordingly, these areas and caves in general have received increased emphasis in conservation efforts because of their high levels of endemism and unique fauna and ecosystems (ELLIOTT, 2000).

Salamanders are a conspicuous component of this unique fauna. Three troglotitic salamander species that all belong to the plethodontid genus *Gyrinophilus* occur in the ILP and AV: *G. gulolineatus* (Berry Cave Salamander), *G. palleucus* (Tennessee Cave Salamander), and *G. subterraneus* (West Virginia Spring Salamander). Because of their complete dependence on subterranean habitats, these species have received considerable attention from biologists seeking to understand the ecology and evolution of cave habitation (BESHARSE AND HOLSINGER, 1977; BRUCE, 1979; MILLER AND NIEMILLER, 2008; NIEMILLER et al., 2008).

However, cave and karst habitats are important not only to troglotitic species, but also to several non-troglotitic amphibian species. Many species of this latter group use

caves on a temporary or semi-permanent basis for aspects of their life histories, including reproduction, refuge from harsh surface conditions (e.g., extreme temperatures or drought), and foraging (WEBER, 2000; BRIGGLER AND PRATHER, 2006; CAMP AND JENSEN, 2007; NIEMILLER AND MILLER, 2007; MILLER et al., 2008). Considerable research conducted on non-obligate, cave-associated salamanders in the ILP and AV karst regions (HUTCHINSON, 1958; CAMP AND JENSEN, 2007; NIEMILLER AND MILLER, 2007; MILLER et al., 2008), have emphasized species' distributions, generation of species lists, and obtaining life-history data; however, most of these studies centered on surveys of just a few species or of relatively few caves. Consequently, limited data are available on the use of cave habitats by amphibian species not typically classified as cave-associated, particularly from Tennessee and northern Alabama. Therefore, we present herein the results of four years of surveys for amphibians and reptiles from 172 caves throughout the karst regions of north Alabama, northwest Georgia, south-central Indiana, southeast Kentucky, Tennessee, southwest Virginia, and southeast West Virginia. Our study represents one of the most comprehensive surveys of cave-associated

amphibians and reptiles in terms of number of caves visited and surveyed, as well as the total number of species and individuals encountered.

2. Materials and Methods

2.1 Study sites.

From June 2004 through December 2008, we conducted 301 surveys of 172 caves throughout the ILP and AV in seven states: north Alabama (14 surveys of 14 caves), northwest Georgia (8 surveys of 7 caves), south-central Indiana (3 surveys of 3 caves), southeast Kentucky (8 surveys of 8 caves), Tennessee (262 surveys of 131 caves), southwest Virginia (5 surveys of 5 caves), and southeast West Virginia (5 surveys of 4 caves). A detailed list of the caves surveyed, including coordinates, can be obtained from the authors. Surveys were conducted during all months of the year with emphasis on periods of favorable stream conditions (i.e., shallow, clear water with low flow): December–February (54 surveys of 44 caves), March–May (70 surveys of 56 caves), June–August (108 surveys of 73 caves), and September–November (69 surveys of 46 caves). Most caves searched contained flowing streams or numerous, isolated pools.

2.2 Survey methods.

To locate aquatic amphibians, we donned wetsuits and slowly walked along, waded through, or crawled in the cave stream and thoroughly scanned the streambed and adjacent stream edge for amphibians. We carefully lifted rocks, cobble, and detritus under which amphibians might seek refuge both in the water and stream edge. Lifted rocks and other cover objects were returned to their original positions to minimize habitat disturbance. We searched crevices in the cave wall and wall proper for terrestrial amphibians and reptiles, particularly near a cave entrance and associated twilight zone. In addition, we searched underneath rocks and other debris for herpetofauna. The developmental stage (egg, larva, juvenile, or adult) of each individual observed was recorded and a count was kept of each species encountered.

2.3 Ecological classification.

We classified species/populations of cave-associated amphibians and reptiles following BARR (1968) into four categories: troglobite (TB), troglophile (TP), troglaxene (TX), and accidental (AC). Note that here we define accidental as an occurrence that is incidental to the larger cave habitat; herpetofaunal observations in this category tend to occur at the cave mouth or in the twilight zone, which is analogous to non-cave habitats such as talus and bluff shelters. Considerable debate continues over the utility

of ecological classification of cave-associated organisms and we refer the reader to SKET (2008) and FENOLIO et al. (this volume) for a review and discussion of this subject and in relation to amphibians, respectively. Historically, the range-wide tendencies of a species indicate the proper cave-associated ecological classification (see SKET, 2008), rather than the attributes of a local population. We agree with POLY AND BOUCHER's (1996) assessment that unique populations of epigeal species capable of subterranean existence or those that utilize subterranean habitats for some aspect of their life history should not be ignored and are of "great importance concerning evolution of cave-dwelling organisms."

3. Results

3.1 Species encountered.

We conducted 301 surveys of 172 caves throughout the ILP and AV in seven states. We recorded 4542 observations of 29 species amphibians and six species of reptile from 151 caves (269 surveys) from 2004–2008. Eighteen species of salamander accounted for 4081 observations from 144 caves (Table 1) including three troglobitic species (*G. gulolineatus*, *G. palleucus*, and *G. subterraneus*). The trogliphilic *Eurycea lucifuga* (Cave Salamander) represented nearly a third of all salamander observations ($n=1267$) and was observed in 73% of caves. *Gyrinophilus porphyriticus* (Spring Salamander) and *Plethodon glutinosus* (Northern Slimy Salamander) were the second and third most frequently encountered salamanders. Eleven species of anurans accounted for 461 observations from 73 caves (Table 2), but eight of these species were classified as accidental. The three most commonly encountered species were not classified as accidental. These three ranids (American Bullfrog, *Rana catesbeiana*; Green Frog, *R. clamitans*; and Pickerel Frog, *R. palustris*) represented 97% of all anuran observations, with *R. palustris* the most frequently encountered species (227 observations from 42 caves). Six reptiles (four snakes, one lizard, and one turtle species) accounted for 11 observations from nine caves (Table 3). All reptiles encountered were categorized as accidental. The *Terrapene carolina* (Eastern Box Turtle) was the most frequently observed species (five observations from four caves).

3.2 Life stages encountered and subterranean reproduction.

Adult was the predominant life stage encountered for the majority of salamanders (Table 1), including two paedomorphic taxa (*G. gulolineatus* and *G. palleucus*); however, larvae of a number of species were also observed, including *Desmognathus conanti* (Spotted Dusky Salamander), *E. cirrigera* (Southern Two-lined Salamander),

Species	Ecological Classification ^a	States (No. of Counties)	No. Caves	No. Surveys	No. Observed	Max. Observed	Life Stages Observed ^b
Family Plethodontidae							
<i>Desmognathus abditus</i>	AC	TN(1)	1	1	1	1	A
<i>Desmognathus conanti</i>	TX/AC	AL(1), GA(1), TN(10)	14	14	37	17	L, A
<i>Desmognathus fuscus</i>	TX/AC	KY(1), VA(1)	2	2	2	1	A
<i>Desmognathus ochrophaeus</i>	AC	WV(1)	2	2	2	1	A
<i>Eurycea cirrigera</i>	TX/AC	GA(1), TN(8), WV(2)	12	18	83	31	E, H, L, J, A
<i>Eurycea longicauda</i>	TP/TX	AL(1), GA(2), KY(1), TN(8), WV(2)	22	32	109	15	L, A
<i>Eurycea lucifuga</i>	TP	AL(5), GA(2), TN(2), KY(1), TN(29), VA(2), WV(1)	125	209	1267	99	E, H, L, J, A
<i>Gyrinophilus gulolineatus</i>	TB	TN(2)	6	28	250	24	H, J, A
<i>Gyrinophilus pallencus necturoides</i>	TB	TN(7)	14	43	459	34	H, J, A
<i>Gyrinophilus pallencus pallencus</i>	TB	AL(1), GA(1), TN(2)	11	17	278	41	J, A
<i>Gyrinophilus porphyriticus</i>	TP	AL(1), GA(2), TN(9), VA(2), WV(2)	28	41	674	84	E, H, L, J, A
<i>Gyrinophilus subterraneus</i>	TB	WV(1)	1	2	45	29	L, A
<i>Hemidactylium scutatum</i>	AC	TN(1)	1	1	1	1	A
<i>Plethodon dorsalis</i>	TX	AL(1), GA(1), TN(12)	21	22	76	31	E, J, A
<i>Plethodon glutinosus</i>	TP/TX	AL(2), GA(2), KY(1), TN(15)	41	48	539	102	J, A
<i>Plethodon petraeus</i>	TX	GA(1)	1	2	6	4	A
<i>Pseudotriton montanus</i>	AC	KY(1)	1	1	1	1	J
<i>Pseudotriton ruber</i>	TP/TX	AL(1), GA(1), TN(8), VA(1)	27	40	249	33	E, H, L, J, A
Family Salamandridae							
<i>Noropthalmus viridescens</i>	AC	TN(2)	2	2	2	1	J
Overall: 18 species		AL(7), IN(2), GA(2), KY(1), TN(31), VA(2), WV(2)	144	261	4081	112	

^a According to Barr (1968): TB – troglolite, TP – troglolite, TN – troglolite, TX – troglolite, VA – troglolite, WV – troglolite, AC – accidental

^b Life Stages: E - eggs, H - hatchling, L - larva, J - juvenile (sexually immature metamorph), A - adult

^c The Georgia record has not been determined to subspecies

Table 1: Abundance, life stages, and ecological classification of salamander species observed during the present study from 2004–2008.

Species	Ecological Classification ^a	States (No. of Counties)	No. Caves	No. Surveys	No. Observed	Max. Observed	Life Stages Observed ^b
Family Bufonidae							
<i>Bufo americanus</i>	AC	TN(2)	3	3	3	1	A
<i>Bufo fowleri</i>	AC	TN(1)	1	1	1	1	A
Family Hylidae							
<i>Acris crepitans</i>	AC	TN(2)	2	2	2	1	A
<i>Hyla chrysoceles</i>	AC	TN(1)	1	1	1	1	A
<i>Pseudacris crucifer</i>	AC	TN(2)	2	2	2	1	A
<i>Pseudacris feriarum</i>	AC	TN(1)	1	1	1	1	A
Family Microhylidae							
<i>Gastrophryne carolinensis</i>	AC	TN(1)	1	1	1	1	A
Family Ranidae							
<i>Rana catesbeiana</i>	TX	AL(3), GA(1), IN(1), KY(1), TN(15), VA(2), WV(1)	33	47	66	4	L, J, A
<i>Rana clamitans</i>	TX	AL(1), GA(1), KY(1), TN(14), VA(2), WV(1)	33	60	156	11	J, A
<i>Rana palustris</i>	TX	AL(2), GA(2), IN(1), KY(1), TN(18)	42	68	227	21	J, A
<i>Rana sphenoccephala</i>	AC	TN(1)	1	1	1	1	A
Overall: 11 species		AL(7), IN(2), GA(2), KY(1), TN(31), VA(2), WV(2)	73	128	461	31	
^a According to Barr (1968): TB – troglobite, TP – troglophile, TX – trogluxene, AC – accidental							
^b Life Stages: L - tadpole, J - juvenile (sexually immature metamorph), A - adult							

Table 2: Abundance, life stages, and ecological classification of anuran species observed during the present study from 2004–2008.

Species	Ecological Classification ^a	States (No. of Counties)	No. Caves	No. Surveys	No. Observed	Max. Observed	Life Stages Observed ^b
Family Colubridae							
Pantherophis spiloides	AC	TN(1)	1	1	1	1	A
Family Crocalidae							
Crotalus horridus	AC	TN(1)	1	1	1	1	A
Family Dipsadidae							
Diadophis punctatus	AC	GA(1), TN(1)	2	2	2	1	A
Family Emydidae							
Terrapene carolina carolina	AC	TN(3)	4	4	5	2	J, A
Family Natricidae							
Nerodia sipedon	AC	TN(1)	1	1	1	1	A
Family Scincidae							
Scincella lateralis	AC	TN(1)	1	1	1	1	A
Overall: 6 species		GA(1), TN(7)	9	10	11	2	

^a According to Barr (1968): TB – troglobite, TP – troglophile, TX – troglone, AC – accidental

^b Life Stages: J - juvenile, A - adult

Table 3: Abundance, life stages, and ecological classification of reptile species observed during the present study from 2004–2008.

E. longicauda (Long-tailed Salamander), *E. lucifuga*, *G. porphyriticus*, *G. subterraneus*, and *Pseudotriton ruber* (Red Salamander). We observed evidence of reproduction (courtship, oviposition, nests, or recently hatched young) for several plethodontids including the *E. cirrigera*, *E. longicauda*, *E. lucifuga*, *G. gulolineatus*, *G. palleucus*, *G. porphyriticus*, *Plethodon dorsalis* (Zigzag Salamander), and *P. ruber*. Detailed descriptions of these observations for many species have been reported elsewhere (see Discussion). Only juveniles or adults were observed for ten of the eleven anuran species (Table 2); however, two tadpoles of *R. catesbeiana* were found in the cave stream of Cow Cave (TWR286), Warren Co., Tennessee, and were, presumably, washed in from a cattle pond located upstream of the main cave. Adults accounted for nearly all reptile observations (Table 3), the only exception was a hatchling *T. carolina* found in Big Mouth Cave (TGD2), Grundy Co., Tennessee. This turtle was nearly dead when found and apparently washed into the cave after a significant rainfall event a few days earlier.

4. Discussion

Many species of non-troglobitic amphibians and reptiles have been reported from subterranean habitats, including caves, and most species we observed have been reported previously from caves. Individuals from any species may accidentally enter a cave (e.g. by falling into a pit, wandering into an entrance by following a stream, or being washed in by an inflowing stream). However, only those individuals with the necessary morphological, physiological, or behavioral adaptations may persist and exploit subterranean habitats for extended periods of time. Throughout the ILP and AV, several amphibian species use caves to varying degrees for aspects of their life histories, including reproduction, foraging, and shelter from harsh surface conditions.

Evidence of reproduction in subterranean habitats was noted for several plethodontid salamander species during this study. Although hatchlings were observed for many species, we observed nests, many with attending females, for several salamanders including *E. cirrigera*, *E. lucifuga*, *G. porphyriticus*, *P. dorsalis*, and *P. ruber*. Nests of *E. lucifuga* and *G. porphyriticus* in caves are not surprising; however, nests of the other three species are noteworthy. Although *E. cirrigera* are occasionally reported from caves (e.g., HIMES et al., 2004 and OSBOURN, 2005), the use of caves for reproduction in this species was first reported for a cave-breeding population in middle Tennessee during the course of this study (NIEMILLER AND MILLER, 2007). Nests of *P. dorsalis* in the literature are few (reviewed

in NIEMILLER AND MILLER, 2008) and all are from subterranean habitats. Some authors have claimed that *P. dorsalis* is not a cave-dwelling species (DODD et al., 2001); however, subterranean nesting and observed aggregations during summer months (NIEMILLER AND MILLER, 2008) suggests this species is more reliant on subterranean habitats than previously perceived. Likewise, *P. ruber* has occasionally been reported from caves in the ILP and AV (BRODE, 1958; GREEN AND BRANT, 1966; BUHLMANN, 2001; OSBOURN, 2005). We previously reported on nests of this species from Tennessee (MILLER AND NIEMILLER, 2005) and Georgia (NIEMILLER et al., 2006), in addition to nesting location, oviposition behavior, and nest defense by attending females (MILLER et al., 2008). Given recent evidence, we argue that at least some populations of this species are adapted and live the majority of their lives in caves and should, therefore, be classified as troglaphiles. As more comprehensive life histories are conducted, we expect that many other non-troglobitic amphibians will be shown to use subterranean habitats for reproduction, which will further obscure the discrete categories of troglaphile and troglaxene.

Several salamanders utilize caves in a seasonal fashion (BRIGGLER AND PRATHER, 2006; CAMP AND JENSEN, 2007) and our results (not shown) also support seasonality of cave use for several species. Although *E. lucifuga* was found year-round, *P. glutinosus* was predominately found during the summer months in the twilight zones of several caves during this study, likely in response to warm and dry surface conditions. Many plethodontids forage and move through the leaf litter of the forest floor. However, surface activities become nearly impossible during periods of extreme heat, cold, or drought. Consequently, the cool and moist environment found in caves and other subterranean haunts provides sanctuary into which herpetofauna can retreat when the surface is inhospitable (BRIGGLER AND PRATHER, 2003; CAMP AND JENSEN, 2007). The anuran *R. palustris* exploits caves for similar reasons. Although our surveys reinforce the observations of others that *R. palustris* has a high affinity for caves (BARR, 1953; BRODE, 1958; GREEN AND BRANT, 1966; CLIBURN AND MIDDLETON, 1983; OSBOURN, 2005), recent work by FENOLIO et al. (2005) suggest that this species is not a significant subterranean predator and caves are being used as refugia only. Similar to most anurans, reptiles are rarely encountered in caves in the ILP and AV (CLIBURN AND MIDDLETON, 1983; OSBOURN, 2005; this study). Most reptile records represent incidental entry into subterranean habitats; however some species, such as *T.*

carolina, may seek refuge in caves during hot, dry periods.

Our study represents one of the most comprehensive surveys of cave-associated herpetofauna, and our data suggest that several non-troglobitic amphibian species are reliant upon caves and subterranean habitats. Many taxa use caves on a temporary or semi-permanent basis for shelter, foraging, and reproduction. Indeed, the use of caves by amphibians is a more complex behavior than previous work has indicated (CAMP AND JENSEN, 2007). Our study adds to a growing body of evidence indicating that in addition to the surrounding forest, caves are critical habitats for many species, and, therefore, should be protected for proper amphibian conservation and management.

Acknowledgements

Funding for this research was provided by the Kentucky Dept. of Fish and Wildlife Resources, Tennessee Wildlife Resources Agency, National Speleological Society, American Museum of Natural History, American Society of Ichthyologists and Herpetologists, Cave Research Foundation, the Dept. of Biology at Middle Tennessee State Univ., and the Dept. of Ecology and Evolutionary Biology and the Univ. of Tennessee-Knoxville. We thank the many volunteers (too many to be listed here) for survey assistance. Research was conducted under permits or authorization from the Alabama DCNR, Georgia DNR, Indiana DNR, Kentucky DFWR, The Nature Conservancy, Southeastern Cave Conservancy, Inc., Tennessee Wildlife Resources Agency, Virginia Cave Board, Virginia DCR, Virginia DGIF, and West Virginia DNR.

References

- Barr TC Jr. 1953. Notes on the occurrence of ranid frogs in caves. *Copeia* 1953: 60–61.
- Barr TC Jr. 1968. Cave ecology and the evolution of troglobites. *Evol. Biol.* 2: 35–102.
- Besharse JC, Holsinger JR. 1977. *Gyrinophilus subterraneus*, a new troglobitic salamander from southern West Virginia. *Copeia* 1977: 624–634.
- Briggler JT, Prather JW. 2006. Seasonal use and selection of caves by plethodontid salamanders in a karst area of Arkansas. *American Midland Naturalist* 155: 136–148.
- Brode WE. 1958. The occurrence of the pickerel frog, three salamanders and two snakes in Mississippi caves. *Copeia* 1958: 47–48.
- Bruce RC. 1979. Evolution of pedomorphosis in salamanders of the genus *Gyrinophilus*. *Evolution* 33: 998–1000.
- Buhlmann KA. 2001. A biological inventory of eight caves in northwestern Georgia with conservation implications. *Journal of Cave and Karst Studies* 63: 91–98.
- Camp CD, Jensen JB. 2007. Use of twilight zones of caves by plethodontid salamanders. *Copeia* 2007: 594–604.
- Cliburn JW, Middleton AL Jr. 1983. The vertebrate fauna of Mississippi caves. *NSS Bulletin* 45: 45–48.
- Dodd, CK Jr, Griffey ML, Corser JD. 2001. The cave associated amphibians of Great Smoky Mountains National Park: review and monitoring. *Journal of the Elisha Mitchell Science Society* 117: 139–149.
- Elliott WR. 2000. Conservation of the North American cave and karst biota. Pp. 665 – 689 *in* *Subterranean Ecosystems*. Wilkens H, Culver DC, Humphreys WF (eds.). Elsevier, Amsterdam.
- Fenolio DB, Graening GO, Stout JF. 2005. Seasonal movement pattern of pickerel frogs (*Rana palustris*) in an Ozark cave and ecological implications supported by stable isotope evidence. *The Southwestern Naturalist* 50: 385–389.
- Green NB, Brant P Jr. 1966. Salamanders found in West Virginia caves. *Proc. West Virginia Acad. Sci.* 38: 42–45.
- Himes JG, Beckett DC, Trousdale AW. 2004. Survey of salamanders in Mississippi limestone caves. *Southeastern Nat.* 3: 241–248.
- Hutchinson VH. 1958. The distribution and ecology of the cave salamander, *Eurycea lucifuga*. *Ecol. Monogr.* 28: 1–20.
- Miller BT, Niemiller ML. 2005. *Pseudotriton ruber* (red salamander). *Reproduction*. *Herpetological Review* 36: 429.
- Miller BT, Niemiller ML. 2008. Distribution and relative abundance of Tennessee cave salamanders (*Gyrinophilus pallescens* and *Gyrinophilus*

- gulolineatus*) with an emphasis on Tennessee populations. Herpetological Conservation and Biology 3: 1–20.
- Miller BT, Niemiller ML, Reynolds RG. 2008. Observations on egg-laying behavior and interactions among attending female red salamanders (*Pseudotriton ruber*) with comments on the use of caves by this species. Herpetological Conservation and Biology 3: 203–210.
- Niemiller ML, Glorioso BM, Gray E, Miller BT, Jensen JB, Keyes T. 2006. *Pseudotriton ruber* (red salamander). Size and subterranean aggregation. Herpetological Review 37: 438.
- Niemiller ML, Miller BT. 2007. Subterranean reproduction of the southern two-lined salamander (*Eurycea cirrigera*) from Short Mountain, Tennessee. Herpetological Conservation and Biology 2: 105–111.
- Niemiller ML, Fitzpatrick BM, Miller BT. 2008. Recent divergence-with-gene-flow in Tennessee cave salamanders (Plethodontidae: *Gyrinophilus*) inferred from gene genealogies. Mol. Ecol. 17: 2258–2275.
- Niemiller ML, Miller BT. 2008. *Plethodon dorsalis* (Zigzag Salamander). Reproduction. Herpetological Review 39: 335.
- Osbourn MS. 2005. The natural history, distribution, and phenotypic variation of cave-dwelling spring salamanders, *Gyrinophilus spp.* Cope (Plethodontidae), in West Virginia. M.Sc. Thesis, Marshall Univ., Huntington, West Virginia.
- Poly WJ, Boucher CE. 1996. Nontroglobitic fishes in caves: their abnormalities, ecological classification and importance. Amer. Mid. Nat. 70: 257–290.
- Sket B. 2008. Can we agree on an ecological classification of subterranean animals? J. of Nat. Hist. 42: 1549–1563.
- Weber A. 2000. Fish and Amphibia. Pp. 109–132 in Subterranean Ecosystems. Wilkens H, Culver DC, Humphreys WF (eds.). Elsevier, Amsterdam.

RECENT RECORDS OF EPIGEAN SALAMANDERS (GENUS *EURYCEA*) FROM CENTRAL TEXAS SPRINGS

CHAD W. NORRIS

Water Resources Branch, Texas Parks and Wildlife Department
4200 Smith School Road, Austin, TX 78744 USA

Recognizing the lack of extensive data on Texas springs and their importance to the natural flow regime of our state's streams and rivers and the biota they support, the TPWD Water Resources Branch set out to document the location and setting of previously unreported springs as well as gather information on the biota present, including salamanders of the genus *Eurycea*.

A total of 65 central Texas springs were surveyed multiple times for *Eurycea* salamanders between August 2003 and September 2008. A total of 35 populations of *Eurycea* sp. were documented from the 65 springs surveyed. Specimens were collected from only 28 of the 35 populations observed, primarily due to landowner concerns, and a majority of the specimens have been deposited at the Texas Natural History Collections (TNHC – UT-Austin). To my knowledge, only four of the 28 populations for which specimens were deposited have been previously reported. The two populations discovered in Kinney County represent a new county record for *Eurycea* sp. and the population discovered at Lower Pinto Springs is significant given this is only the second locality for *Eurycea* in the Rio Grande Basin of Texas. A majority of the populations documented belong to the *E. troglodytes* complex, in part due to the large geographic area covered by this group. It is the author's hope that these collections will assist in refining the taxonomy of this complex, as well as other groups within the genus, and aid in defining the geographic boundaries of particular groups. Specimens collected and notes on their habitat occurrences are provided. I also provide notes of interest on populations that were encountered but from which no individuals were collected.

1. Introduction

The Edwards Plateau region of central Texas is characterized by extensive Lower Cretaceous limestones that have been thoroughly dissected and eroded to expose numerous springs (Rose 1970; Brune 1981) that form the headwaters of and provide baseflow to numerous creeks and several major rivers. This region of the state is widely recognized as an area rich in endemic and relict populations of aquatic organisms (Bowles and Arsuffi 1993; Ourso and Hornig 1999), whose persistence is owed largely to the relative thermal and hydrologic stability provided by springs. Many of these organisms have restricted geographic distributions, due in part to their narrow life history requirements and the isolated nature of many springs. The taxonomic status for many of these species remains uncertain, and among these taxa are many of the salamanders of the genus *Eurycea*.

The genus *Eurycea* includes 27 described species (AmphibiaWeb 2009), almost half (13) of which are endemic to central Texas. Most of the remaining described species occur east of the Mississippi River, from Florida west to eastern Oklahoma and north to Canada, many kilometers from the disjunct populations in central Texas.

Major distributional information on the *Eurycea* of Texas was compiled and expanded upon by Baker (1961). This work summarized *Eurycea* accounts from nine counties, included new records from six counties, and expanded the range of *E. neotenes* westward to Val Verde County and northward to Williamson County. Sweet (1982) noted that few new localities for *E. neotenes* had been reported in recent years and offered localities for 100 populations. This information added many new localities but only slightly expanded the range of *E. neotenes* and did not include any new county records. Chippindale et al (2000) examined specimens that represented 64 populations of *Eurycea* from across much of the Edwards Plateau, 22 of which were previously documented by Sweet (1982). Most recently, Bendik (2006) examined 43 populations of *Eurycea* from the eastern Edwards Plateau, many of which were previously documented. Thorough summaries of the taxonomic and systematic history of the genus *Eurycea* are provided by Sweet (1982), Chippindale et al. (2000), and Bendik (2006).

Documenting localities for *Eurycea* populations is problematic for several reasons, including the elusive nature of salamanders and the complexity of many spring

habitats, but perhaps the biggest issues are the lack of data on the location and extent of Texas springs and the need for acquiring access to private lands to survey springs for *Eurycea*. Recognizing the lack of extensive data on the full distribution and extent of Texas springs and the general importance of springs to the natural flow regime of our state's streams and rivers and the biota they support, the TPWD Water Resources Branch set out to document the location and setting of previously unreported springs as well as gather information on the biota they support, including salamanders of the genus *Eurycea*. This paper is one product from this ongoing research.

2. Methods

Survey reaches generally began at the downstream end of what was deemed suitable *Eurycea* habitat (i.e. areas where water temperature remained close to that of the emerging spring with moderate flow and sufficient cover) and rarely exceeded 20 meters from the spring source. The number of salamanders observed was enumerated and the amount of time taken to survey each reach was noted. Field notes were taken on the habitat conditions as well as the geologic setting of the springs. Additionally, spring discharge was estimated and basic water quality parameters (temperature, dissolved oxygen, TDS, specific conductance, and pH) were measured. Many of the springs were sampled on multiple occasions with salamander occurrence varying.

3. Results

A total of 65 springs were surveyed for *Eurycea* salamanders

between August 2003 and September 2006. A total of 35 populations of *Eurycea* were documented from the 65 springs surveyed (Fig. 1). Specimens were collected from only 28 of the 35 populations observed, primarily due to landowner concerns, and specimens have been deposited at the Texas Natural History Collections (TNHC) at the University of Texas (UT) at Austin and the Amphibian and Reptile Diversity Research Center at the University of Texas at Arlington. To our knowledge, only four of the 28 populations for which specimens were deposited have been previously reported. A majority of the salamanders collected were previously referred to as *E. neotenes* (Sweet 1977, 1978, 1982). However, Chippindale et al. (2000) provide evidence to now assign most of these specimens primarily to one of four groups; *E. pterophila*, *E. neotenes*, the *E. latitans* complex, or the *E. troglodytes* complex. A summary of the specimens collected and the geology of the springs is provided below by taxonomic group as delineated by Chippindale et al. (2000) (Table 1). We also provide notes on populations that were encountered but from which no individuals were collected.

4. Recent Records of *Eurycea* Populations

Eurycea pterophila – Blanco River salamander. Populations of *E. pterophila* were observed at five spring locations in the Blanco River drainage; Fern Bank, Jacobs Well, Koch, White, and Narrows springs. Specimens were collected from Fern Bank and Koch springs by the author and specimens were also collected from Narrows Springs by Travis LaDuc (TNHC). Although Jacobs Well and White

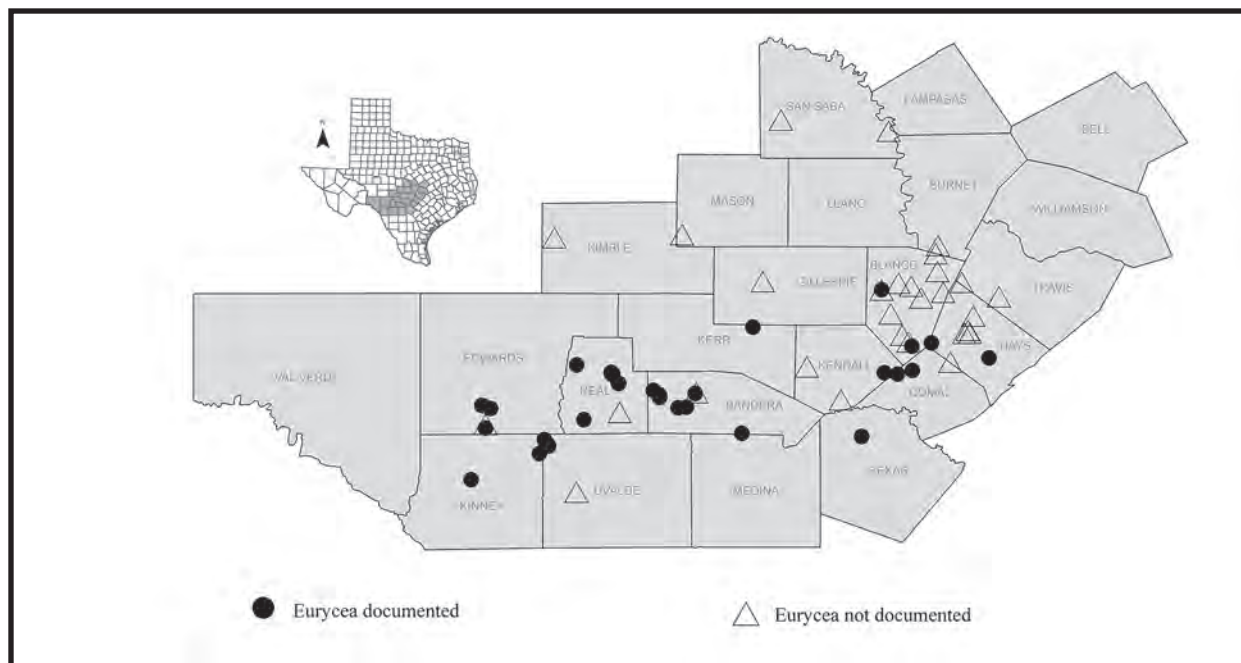

Figure 1: Location of central Texas springs surveyed for *Eurycea* salamanders.

Spring Name	County	River Basin	Geologic Formation	Aquifer
Bauerlein Spring*	Bandera	Medina	Fort Terrett	Edwards-Trinity
Kitchen Springs*	Bandera	Medina	Fort Terrett	Edwards-Trinity
Lower Willow Springs*	Bandera	Sabinal	Fort Terrett	Edwards-Trinity
Wedgeworth Springs (North)	Bandera	Sabinal	Fort Terrett	Edwards-Trinity
Wedgeworth Springs (South)	Bandera	Sabinal	Fort Terrett	Edwards-Trinity
West Verde Springs*	Bandera	Medina	Upper Glen Rose	Upper Trinity
Wishing Wells Springs	Bandera	Sabinal	Fort Terrett	Edwards-Trinity
Huerta Spring*	Bexar	Guadalupe	Upper Glen Rose	Upper Trinity
Lost Dog Spring	Bexar	Guadalupe	Lower Glen Rose	Middle Trinity
Hope Spring*	Blanco	Pedernales	Riley	None
Koch Springs*	Blanco	Blanco	Upper Glen Rose	Upper Trinity
White Springs	Blanco	Blanco	Lower Glen Rose	Middle Trinity
Magic Springs*	Comal	Guadalupe	Lower Glen Rose/Hensell Sand	Middle Trinity
Rebecca Springs	Comal	Guadalupe	Cow Creek Limestone	Middle Trinity
Kickapoo Springs*	Edwards	West Nueces	Devils River	Edwards-Trinity
Lacey Spring*	Edwards	West Nueces	Devils River	Edwards-Trinity
Paisano Spring*	Edwards	West Nueces	Devils River	Edwards-Trinity
West Nueces Springs*	Edwards	West Nueces	Devils River	Edwards-Trinity
Fern Bank Springs	Hays	Blanco	Kainer	Edwards (BFZ)
Narrows Springs*	Hays	Blanco	Lower Glen Rose	Middle Trinity
Edge Falls Springs*	Kendall	Guadalupe	Lower Glen Rose/Hensell Sand	Middle Trinity
Rocky Ridge Springs*	Kerr	Guadalupe	Fort Terrett	Edwards-Trinity
Boiling Springs*	Kinney	Nueces	West Nueces	Edwards-Trinity
Lower Pinto Springs*	Kinney	Rio Grande	Buda Limestone	Edwards-Trinity
Church Springs*	Real	Frio	Fort Terrett	Edwards-Trinity
Lower Bee Cave Springs	Real	Frio	Fort Terrett	Edwards-Trinity
Morris Springs*	Real	Nueces	Fort Terrett	Edwards-Trinity
Paint Bluff Springs*	Real	Frio	Fort Terrett	Edwards-Trinity
Russell Spring*	Real	Nueces	Devils River	Edwards-Trinity
Short Prong Springs	Real	Frio	Fort Terrett	Edwards-Trinity
Upper Bee Cave Springs*	Real	Frio	Fort Terrett	Edwards-Trinity
Hog Woller Springs*	Uvalde	Nueces	Devils River	Edwards-Trinity
Machinery Hollow Springs*	Uvalde	Nueces	Fort Terrett	Edwards-Trinity
Montell Springs	Uvalde	Nueces	Devils River	Edwards-Trinity
Wells Springs	Uvalde	Nueces	Devils River	Edwards-Trinity

Table 1: Springs with *Eurycea* populations and associated county, river basin, geologic formation, and aquifer.

* indicates springs with previously undocumented localities for *Eurycea*.

Springs were not previously reported in published records to contain *Eurycea*, recent collections had been made by other researchers so no specimens were collected (Andy Gluesenkamp, personal communication, 2005). To my knowledge *Eurycea* have not been previously reported from Koch or Narrows springs. However, Sweet (1982) reported salamanders from Blanco River Spring, which is located about 1.7 km east/northeast from Koch Springs. Blanco River Spring was located in March 2005 and several

subsequent surveys have resulted in no *Eurycea* individuals observed. Two additional springs in Blanco County were found to contain *Eurycea*, but landowners did not provide consent to collect specimens so these localities are not included in this report.

Eurycea latitans complex – Cascade Caverns salamander. Salamanders that belong to the *E. latitans* complex were observed at three springs; Edge Falls Springs in Kendall

County and Rebecca and Magic springs in Comal County. Specimens were collected from all three springs. The Rebecca Springs population was previously reported by Sweet (1978), but no specimens had been collected from this site in over 30 years. The populations at Edge Falls and Magic springs represent newly documented localities for *Eurycea* salamanders and may provide critical insight toward geographic boundaries and systematic placement of species as both occur in an area where the range of *E. latitans*, *E. pterophila*, and *E. neotenes* converge. Sweet (1982) reported a population from East Curry Creek Spring in Kendall County, which is 3-4 km northwest of Edge Falls Springs.

Eurycea neotenes – Texas salamander. The type locality for *E. neotenes* is Helotes Springs outside Helotes, Texas. Helotes Springs were visited in June 2008, but the springs were dry and no surface water or salamanders were observed. Populations of *E. neotenes* were observed at two springs in northwest Bexar County; Huerta and Lost Dog springs. A specimen was collected from Huerta Spring as this locality had not been previously reported. A specimen from Lost Dog Spring was collected by Andy Gluesenkamp (personal communication 2005) and was later used in genetic analysis of the southeastern central Texas *Eurycea* (Bendik 2006). Both Huerta and Lost Dog springs are intermittent in nature and often cease to flow during dry summer months, as is the case with most of the remaining springs in northwest Bexar County. Despite extended periods without surface water (as long as 12-18 months), *E. neotenes* was abundant (> 5 observed in ten minutes) at each spring when water returned to the surface.

Eurycea troglodytes complex – Valdina Farms salamander. Numerous populations of salamanders that belong to the *E. troglodytes* complex (Chippindale et al. 2000) were observed at springs in Bandera, Edwards, Gillespie, Kerr, Kinney, Real, and Uvalde counties. Most of these populations are previously unreported. Observed populations that belong to the *Eurycea troglodytes* complex and notes on their occurrence are discussed below by county.

Bandera County - Many localities for *Eurycea* have been reported from Bandera County. Baker (1961) reported six localities but only offered vague site descriptions with no coordinates or spring names. Sweet (1982) reported 16 localities for *Eurycea* from Bandera County while Chippindale et al. (2000) reported only three localities, all of which were previously reported by Sweet (1982).

Four populations of salamanders that should be referred

to the *E. troglodytes* complex were documented at Wishing Well, Wedgeworth (North and South), and Lower Willow springs in the Sabinal River drainage, Bandera County. Specimens were collected from each of these springs. Three additional populations of salamanders that should be referred to the *E. troglodytes* complex were observed at Bauerlein, Kitchen, and West Verde springs in the Medina River Basin, Bandera County. All of the aforementioned springs in Bandera County issue from the base of the Fort Terrett Member of the Edwards Group limestone (Edwards-Trinity Aquifer), except for West Verde Springs which issues from the Upper Glen Rose Limestone.

Four of the six populations discovered in Bandera County (Lower Willow, Kitchen, Bauerlein, and West Verde springs) represent new localities for *Eurycea* salamanders. Chippindale et al. (2000) previously reported *Eurycea* from Wishing Well Springs, although they referred to the springs as Sabinal Canyon Spring. Salamanders were also previously reported from Wedgeworth Springs (north and south) by Sweet (1977, 1982) and Chippindale et al. (2000), who referred to Wedgeworth South Spring as Murphy's Spring. Sweet (1982) reported a population of salamanders within the same drainage as Lower Willow Springs (i.e., Mill Creek), but the locality is 5-6 km to the north of Lower Willow Springs based on spatial analysis using geographical information systems (GIS). Noteworthy was the observation of a *Eurycea* individual on May 24, 2004 in Wishing Well Springs consuming a cave cricket (*Ceuthophilus* sp.) on the margins of a small pool in about 2.5 cm of water. Prior to this, cave crickets were observed around the pool but not in the water, suggesting the salamander left the water to capture its prey. This is interesting because the only reports of transforming *Eurycea* individuals are from springs in the Sabinal River drainage (Sweet 1977).

Edwards County - Five previously reported localities for *Eurycea* from Edwards County were found. Baker (1961) reported a *Eurycea* locality 6.4 km north of Barksdale and Sweet (1982) listed three localities within 15 km of Barksdale from southeastern Edwards County. More recently, Chippindale et al. (2000) reported a locality from West Nueces River Spring, which is located about 7 km downstream of Kickapoo Springs according to spatial analysis using GIS.

Eurycea were collected from four springs (Kickapoo, West Nueces, Paisano, and Lacey springs) in the West Nueces River Basin in Edwards County, all of which represent new localities. Individuals from these localities should be referred to the *E. troglodytes* complex – Carson Cave

Group. It is worth noting that these springs are within 11 km of each other and are all in close connection with the West Nueces River. The river is characterized by extensive alluvial deposits (cobble and gravel) and disappearing and reappearing surface flow, which seem conducive to salamanders communicating between localities and surviving drought in this semi-arid environment.

Kerr County – Salamanders have been reported from several springs in Kerr County. Milstead (1951) and Baker (1961) each report collections from Turtle Creek, while Bruce (1976) reported two localities. Sweet (1982) reported collections from 19 springs, including North Fork Guadalupe River Spring. Salamanders that should be referred to *E. troglodytes* complex were collected from one spring in Kerr County, Rocky Ridge Springs. North Fork Guadalupe River Spring, which is a large spring (> 10 cfs average discharge) that forms the headwaters of the North Fork Guadalupe River, was surveyed on six separate occasions for salamanders, but no *Eurycea* were observed.

Kinney County - Salamanders were collected from two springs in Kinney County, Lower Pinto Springs in the Rio Grande River Basin and Boiling Springs in the West Nueces River Basin. These represent the first report of *Eurycea* from Kinney County. The population of salamanders discovered at Lower Pinto Springs is significant because it bridges a gap between previously reported *Eurycea* localities in southeastern Edwards County and southern Val Verde County (Del Rio). It is worth noting that one of the state's largest springs, Las Moras Springs, is located about 12 km south of Pinto Springs in Kinney County. To my knowledge, no *Eurycea* have been collected from Las Moras Springs. Sweet (1982) reported surveying Las Moras Springs for *Eurycea*, but none were found.

Real County - There are numerous previously reported localities for *Eurycea* in Real County. Baker (1961) reported four localities for *Eurycea*, but only offered vague locality descriptions and no coordinates or spring names. Sweet (1982) documented 13 localities in Real County and Chippindale et al. (2000) reported an additional four localities.

Eurycea were found at six localities in Real County, three of which are previously unreported. Two springs in the Upper Frio River Basin that were found to contain *Eurycea*, lower Bee Cave and Short Prong Frio River springs, were previously reported by Sweet (1982). The four previously unreported localities are from Morris Springs in the East Nueces River Basin, Russell Springs in the Nueces River

Basin, and Church, Paint Bluff, and upper Bee Cave springs in the Frio River Basin. All of these springs, with the exception of upper Bee Cave Springs, issue from the base of either the Fort Terrett Member or Devils River limestone, which again are equivalent geologic units. Bee Cave Springs was divided into an upper and lower group of springs. The upper springs appear to issue from high in the Fort Terrett Member (and may be influenced by the overlying Segovia Member), while the lower springs issue from a lower elevation in the Fort Terrett Member.

On October 17, 2005, three dead *Eurycea* individuals were observed in the stream, all of which were split open with the skeleton intact but no internal tissue. While the cause of death was not evident, the abundance of backswimmers (Notonectidae: *Notonecta* and *Buenoa* sp.) present on this date was noted. Backswimmers, like other hemipterans, have piercing mouthparts used to penetrate their prey, inject hydrolytic enzymes and suck out the resulting juices. During a return visit to Russell Springs in Spring of 2006, a backswimmer was observed grasping a small, dead *Eurycea* individual. This suggests the previously observed dead *Eurycea* may have fallen prey to backswimmer predation as well.

Uvalde County – Baker (1961) reported three localities for *Eurycea* in Uvalde County, but offered no coordinates. Sweet (1982) reported *Eurycea* from 5 springs in Uvalde County, while Chippindale et al (2000) reports three additional localities. *Eurycea* salamanders were collected from four springs in Uvalde County; Wells, Montell, Machinery Hollow, and Hog Woller springs. All of these springs are within the same creek drainage and Wells and Montell springs are within a few hundred meters of each other, on opposite sides of an alluvial divide and may represent the same population. Baker (1961) reported *Eurycea* collected from Wells and Montell springs, but Machinery Hollow and Hog Woller springs represent new localities.

Eurycea species – Salamanders were collected from Hope Spring in Blanco County. This is the only spring found to contain *Eurycea* that does not issue from Cretaceous limestones. Hope Spring issues from an outcrop of the Cap Mountain Limestone at its contact with the underlying Lion Mountain Sandstone. Both of these units are part of the Riley Formation, which is Cambrian in age. The Glen Rose Limestone and Hensell Sand formations are located 1-2 km west and south of the Cap Mountain Limestone Member. Abundant faulting mapped in the area may provide a hydrogeologic connection between the

formations. However, block faulting is common in this area and may have isolated this population. A nearby spring (120 m southwest), Rock Spring, lies at approximately the same elevation (450 m) and is presumably fed by the same source, but no *Eurycea* were found in this spring.

Placement of this population within the taxonomic groups delineated by Chippindale et al. (2000) was problematic because this population occurs in an area where the *E. pterophila* complex (to the east/southeast), *E. troglodytes* complex (to the west/southwest), and the Pedernales population (to the east) converge. Hence, this population may provide critical insight into species boundaries. Of note at Hope Spring was the observation of a stressed salamander (i.e. pale white, lesions, and missing digits) covered with amphipods (*Hyallolella azteca* complex). The landowners indicated they recently removed mats of watercress (*Nasturtium* sp.) from the bedrock substrate of the spring run because it was impeding flow. Since amphipods are often abundant in mats of vegetation such as this, it is likely its removal reduced cover and ultimately resulted in overcrowded conditions. However, it is unclear if the amphipods caused the stress or merely exacerbated it.

5. Discussion

Despite several decades of study, much remains unresolved with the taxonomy of the central Texas *Eurycea*. Recent molecular studies (Chippindale et al. 2000, Hillis et al. 2001, Bendik 2006) have identified major monophyletic groups and set the basis for more detailed studies of the systematic and taxonomic relationships of the group. Documenting new localities and populations of *Eurycea* is necessary to refine the relationships and species boundaries within and among the currently recognized taxa, but is also a critical first step that benefits more than our knowledge of this particular group.

Resolving taxonomic questions of the central Texas *Eurycea* adds to the body of knowledge on the biodiversity of karst aquatic ecosystems in central Texas, is important for addressing conservation issues, provides insight into the history of other central Texas organisms, and serves as a model for studies of other organisms or ecosystems. The karst aquatic ecosystems of central Texas provide habitat for 91 endemic species, including 44 troglobitic species (Ourso and Hornig 1999). As the taxonomy of the central Texas *Eurycea* and other groups with unresolved taxonomy (e.g., Amphipoda: *Hyallolella azteca* complex) is further refined, the number of endemic species will likely grow. The identification of "endemic hotspots" through distributional analysis will likely prove valuable in addressing conservation

issues and directing conservation efforts to preserve the unique natural biotic diversity of central Texas.

The historical biogeography of the central Texas *Eurycea* has likely been influenced by major events that also shaped the history of many other groups of organisms, such as other spring-adapted endemics. Gaining a better understanding of the events that shaped the current biogeography of the central Texas *Eurycea* may aid in piecing together the historical biogeography of other species. Similarly, understanding the evolution of this group and the processes or events that affected it serves as a case study or model for studying other ecosystems and evolutionary processes.

As Texas springs continue to be lost, populations of rare species, such as *Eurycea* salamanders, will become increasingly rare, the gaps in information will increase, and deciphering the evolution and biogeography of these species will become more difficult.

References

- AMPHIBIAWEB: Information on amphibian biology and conservation. [web application]. 2009. Berkeley, California: AmphibiaWeb. Available: <http://amphibiaweb.org/>. (Accessed: Jan 23, 2009).
- BAKER, J. (1961) Distribution of and key to the neotenic *Eurycea* of Texas. *The Southwestern Naturalist* 6(1), 27–32.
- BENDIK, N.F. (2006) Population genetics, systematics, biogeography, and evolution of the southeastern Central Texas *Eurycea* Clade Blepsimolge (Plethodontidae). Unpublished Masters Thesis, University of Texas at Arlington, 127 p.
- BOWLES, D.E. and T.L. ARSUFFI (1993) Karst aquatic ecosystems of the Edwards Plateau region of central Texas, USA – A consideration of their importance, threats to their existence, and efforts for their conservation. *Aquatic Conservation, Marine and Freshwater Ecosystems* 3:317–329.
- BRUCE, R. (1976) Population structure, life history and evolution of paedogenesis in the salamander *Eurycea neotenes*. *Copeia* 2, 242–249.
- BRUNE, G. (1981) *Springs of Texas: Volume 1*. Texas A&M University Press Agricultural Series, no. 5, 566 p.

- CHIPPINDALE, P.T., A.H. PRICE, J.J. WIENS, and D.M. HILLIS (2000) Phylogenetic relationships and systematic revision of central Texas hemidactyliine plethodontid salamanders. *Herpetological Monographs*, 14, 1–80.
- HILLIS, D.M., D.A. CHAMBERLAIN, T.P. WILCOX, and P.T. CHIPPINDALE (2001) A new species of subterranean blind salamander (Plethodontidae: Hemidactyliini: *Eurycea*: *Typhlomolge*) from Austin, Texas, and a systematic revision of central Texas paedomorphic salamanders. *Herpetologica*, 57, 266–280.
- MILSTEAD, W. (1951) A new locality record for the Texas neotenic salamander, *Eurycea latitans*. *Herpetological* 7, 57-58
- OURSO, R.T. and C.E. HORNIG (1999) Stream and aquifer biology of South-Central Texas – A literature review, 1973-97. U.S. Geological Survey, open-file report 99–243, 38p.
- ROSE, P. (1970) Edwards Group, surface and subsurface, Central Texas. University of Texas Bureau of Economic Geology, Report of Investigations No. 74, 198 p.
- SWEET, S. (1977) Natural metamorphosis in *Eurycea neotenes*, and the generic allocation of the Texas *Eurycea* (Amphibia: Plethodontidae). *Herpetologica* 33, 364–375.
- SWEET, S. (1978) The evolutionary development of the Texas *Eurycea* (Amphibia: Plethodontidae). Unpublished dissertation, University of California, Berkeley, 450 p.
- SWEET, S. (1982) A distribution analysis of epigeal populations of *Eurycea neotenes* in central Texas, with comments on the origin of troglotic populations. *Herpetologica* 38(3), 430–444.

ESTIMATION OF JOLLYVILLE PLATEAU SALAMANDER (*EURYCEA TONKAWAE*) POPULATIONS USING SURFACE COUNTS AND MARK-RECAPTURE

LISA O'DONNELL¹ and ANDY GLUESENKAMP²

¹City of Austin, Austin Water Utility, Balcones Canyonlands Preserve, Austin, TX 78738

²Texas Memorial Museum, University of Texas, Austin, TX 78705 and 700 Billie Brooks Drive, Driftwood, TX 78619

The Jollyville Plateau salamander (*Eurycea tonkawae*) is a perennibranchiate salamander found only in springs, spring runs, and subterranean streams in the Northern Edwards Aquifer northwest of Austin, Texas. This species is currently a candidate for listing under the Endangered Species Act due to threats from urban development throughout its limited range and corresponding negative trends in surface counts at several long-term monitoring sites. During 2007, the city of Austin initiated mark-recapture surveys of *E. tonkawae* populations at three spring sites and has compared the results with surface count surveys, which have been conducted as part of a long-term monitoring program since 1997. The mark-recapture study was conducted monthly over an 8-month period using Pollock's robust design. Mark-recapture surveys are considerably more labor-intensive, yet provide critical information that cannot be obtained solely from surface counts, including detection probabilities, total population size, vital rate estimates (emigration/immigration, persistence), and surface movement. During this study, detection probabilities varied from month-to-month, but the mean probabilities were similar across all three sites. These preliminary results indicate that, under ideal habitat conditions (e.g., consistent spring flow, suitable cover, and few predators), surface counts should represent a consistent fraction of the total population and thus provide a reliable index of the total population size. However, "ideal" conditions such as the continuous flows that occurred throughout the 2007 study are rare. Typically, flow and other habitat conditions are highly variable and may be absent for prolonged periods (due to drought or degradation from urbanization). The interaction of these variables as well as season and antecedent conditions is likely to influence the direction and degree of response in *E. tonkawae* populations and the relationship between surface counts and total population size. Thus, continuing mark-recapture at a subset of the monitoring sites is recommended to better understand how populations respond under less than ideal conditions, monitor variability in detection probabilities over a longer period of time, adjust surface count data as needed, and gather other data that cannot be obtained from surface counts.

1. Introduction

E. tonkawae occurs nine creek watersheds (Brushy, Bull, Buttercup, Cypress, Lake, Long Hollow, Shoal, Walnut, West Bull) in the Northern Edwards Aquifer (Fig. 1). City of Austin staff have been monitoring this species using direct counts in surface habitats, including spring pools, spring runs, and riffles dominated by spring flows, since 1997. Because *E. tonkawae* also inhabits subsurface habitats, as indicated by its re-emergence from springs that begin to flow after dry spells and anecdotal evidence suggesting that egg deposition occurs underground, estimation of the total population size is not possible using surface counts. To obtain estimates of detection probabilities and total population size for this species, an intensive mark-recapture study was conducted from March-October 2007. O'DONNELL et al. (2008) provides a comprehensive report of the 2007 mark-recapture study.

2. Methods

Mark-recapture was conducted from March through October 2007 at three spring sites in two creek watersheds (Bull Creek, Long Hollow) (Fig. 2). The mark-recapture method followed Pollock's robust design (KENDALL AND HINES, 1999; KENDALL et al., 1997; KENDALL AND BJORKLAND, 2001; BAILEY et al., 2004a-c; THOMPSON, 2004; AMSTRUP et al., 2005), resulting in eight primary sampling periods for two of the study sites (Lanier Spring and Wheless Spring) and six primary sampling periods for one study site (Lower Ribelin Spring). During each primary period, surveys were conducted on three consecutive days (secondary periods).

E. tonkawae greater than 16 mm snout-vent length were marked using a combination of elastomer marking (Northwest Marine Technology Inc., Shaw Island, Washington) and photo-identification. For the elastomer

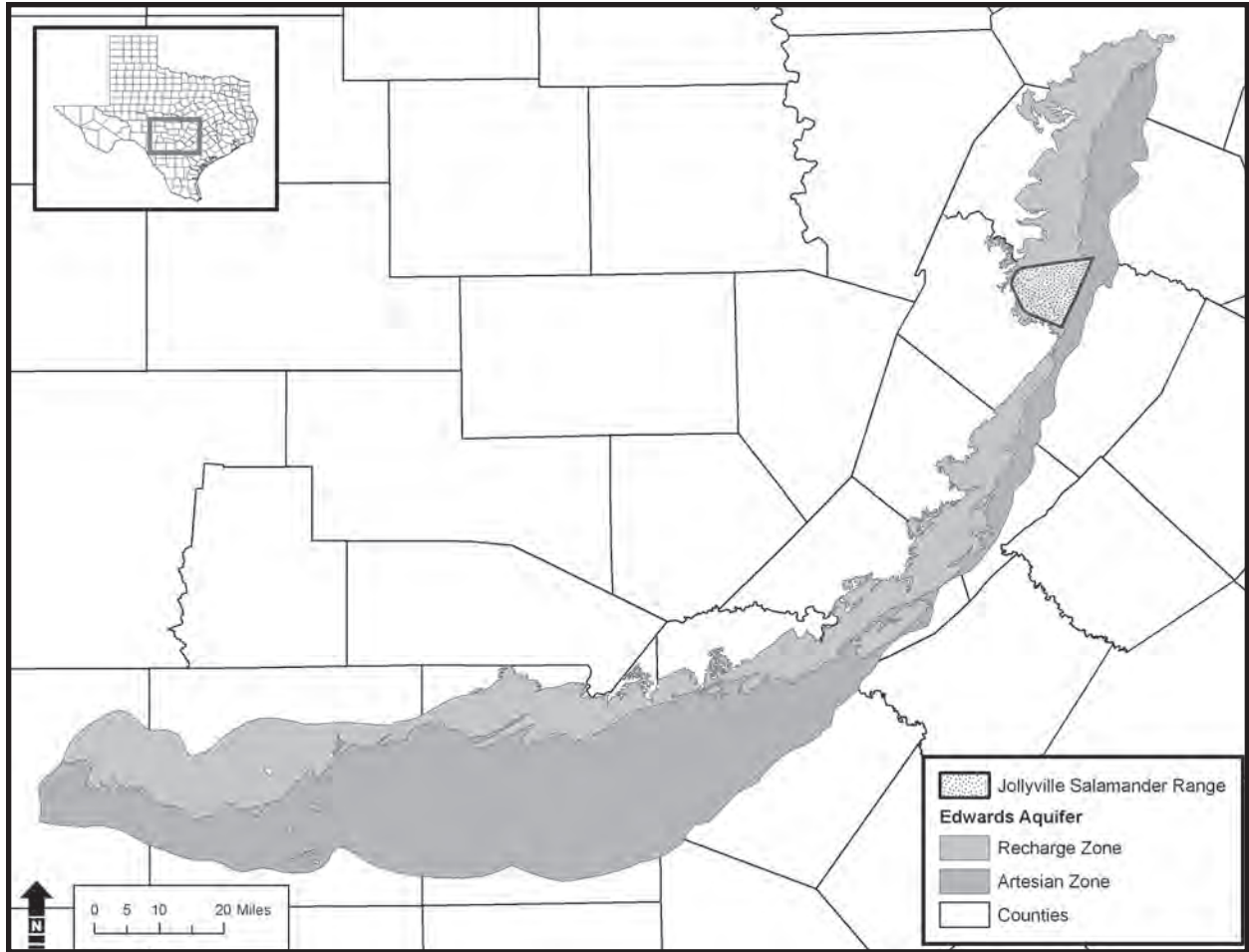

Figure 1: Range of *Eurycea tonkawae* within the Edwards Aquifer, Travis and Williamson counties, Texas.



Figure 2: Location of *Eurycea tonkawae* mark-recapture sites, Travis County, 2007.

marking, individuals were anaesthetized in a solution of 0.25g Tricaine S (MS-222)/L of spring water. Sterile 28-gauge insulin syringes were used to inject tiny amounts (2-20 uL) of visible implant elastomer (VIE) just underneath the skin to form a soft colored bead. Each individual was given three VIE marks using a combination of up

to six different colors (blue, red, orange, yellow, white, black) in five locations on the body (Fig. 3). The use of six colors in five locations, with a maximum of three marks per individual, allowed for 2,550 unique combinations. Because of the unlikelihood of any movement between the Bull Creek and Long Hollow sites, the same list of color combinations was used so that up to 2,550 *E. tonkawae* could be marked in both of these watersheds.

Photographs were used to verify that all recaptures had been correctly identified based on matching the VIE marks and the unique patterns of melanophores and iridiphores for each individual. Photo-identification using natural patterns has been used successfully on many different species, including *Eurycea* (BAILEY, 2004) and other salamander species (LOAFMAN, 1991; HEYER et al., 1994; DOODY, 1995; SMITH, 2004; GAMBEL et al., 2007). Photographs have also been used previously to identify *E. tonkawae* individuals in the field and captivity (O'DONNELL et al., 2006).

Mark-recapture data were analyzed using MARK version 4.3.

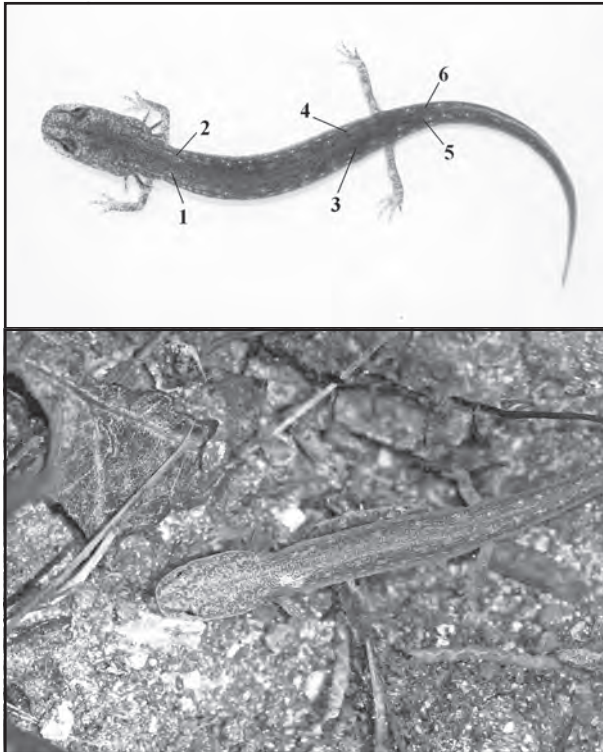

Figure 3: Locations of visible implant elastomer marks on an *Eurycea tonkawae* individual (the sixth location was discontinued) and a recaptured individual.

3. Results and Discussion

Over the 8-month study period, a total of 2,165 *E. tonkawae* were caught and marked with VIE: 463 at Lanier Spring, 281 at Lower Ribelin, and 1,421 at Wheless Spring. Population parameter estimates were estimated for detection probabilities, persistence, temporary migration, surface population size, and superpopulation size (figs. 4-6). While

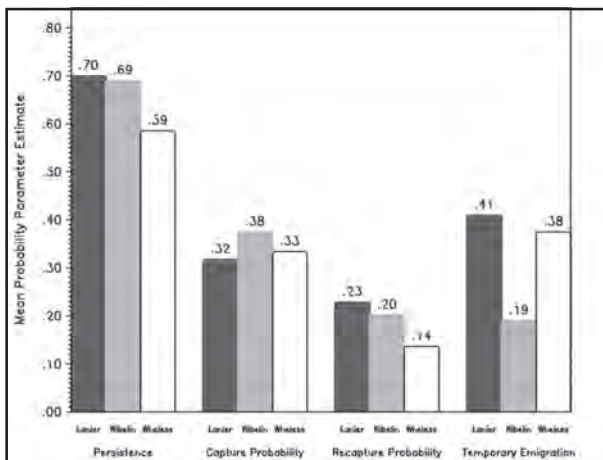

Figure 4: Estimated mean persistence, capture probability, recapture probability, and temporary emigration for *Eurycea tonkawae* at Lanier Spring, Lower Ribelin, and Wheless Spring, 2007.

the parameter estimates varied considerably by time and site, the means were not significantly different between sites despite differences in surface habitat conditions. These data suggest that thorough surface counts under ideal conditions (i.e., consistent spring flows) at these sites should, on average, result in the capture of about 30-40% of the surface population and 15 to 25% of the superpopulation (total population within the surface and subsurface associated with the study area).

While the overall means were similar among all three sites, there was month-to-month variability in most of the population parameters. Habitat conditions appeared to be the major influence, particularly spring flows and the amount and extent of suitable cover (loose, unembedded rocks), both of which provided avenues for dispersal in and out of the study area. The site with limited suitable cover beyond the study area (Lower Ribelin) had the least amount of variation and narrowest confidence intervals. The sites with habitat beyond the study area (Lanier Spring, Wheless Spring), more variable spring flows, and/or multiple portals to the subsurface (Wheless Spring) tended to have more variability in the parameter estimates.

4. Conclusions

The results of the 2007 mark-recapture study suggest that surface counts should continue to be a useful tool in evaluating the population status of *E. tonkawae*. They provide a cost-effective alternative to the more labor-intensive mark-recapture method and are a less intrusive method of estimating population size. While the mark-recapture study presented here is by no means an exoneration of surface counts as a poor estimator of

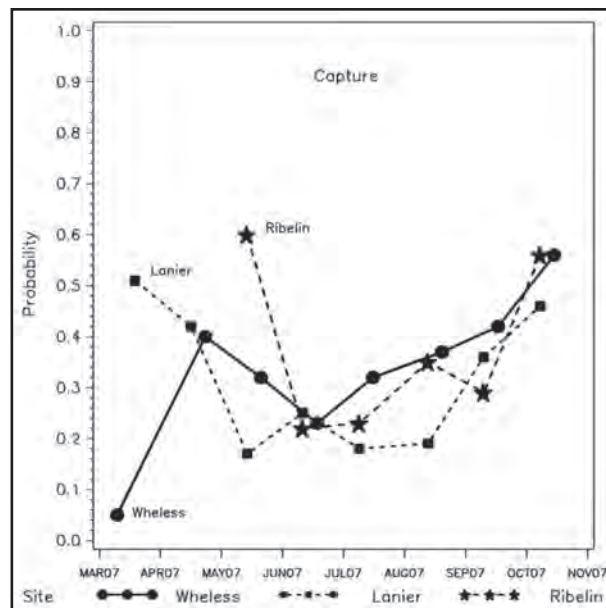

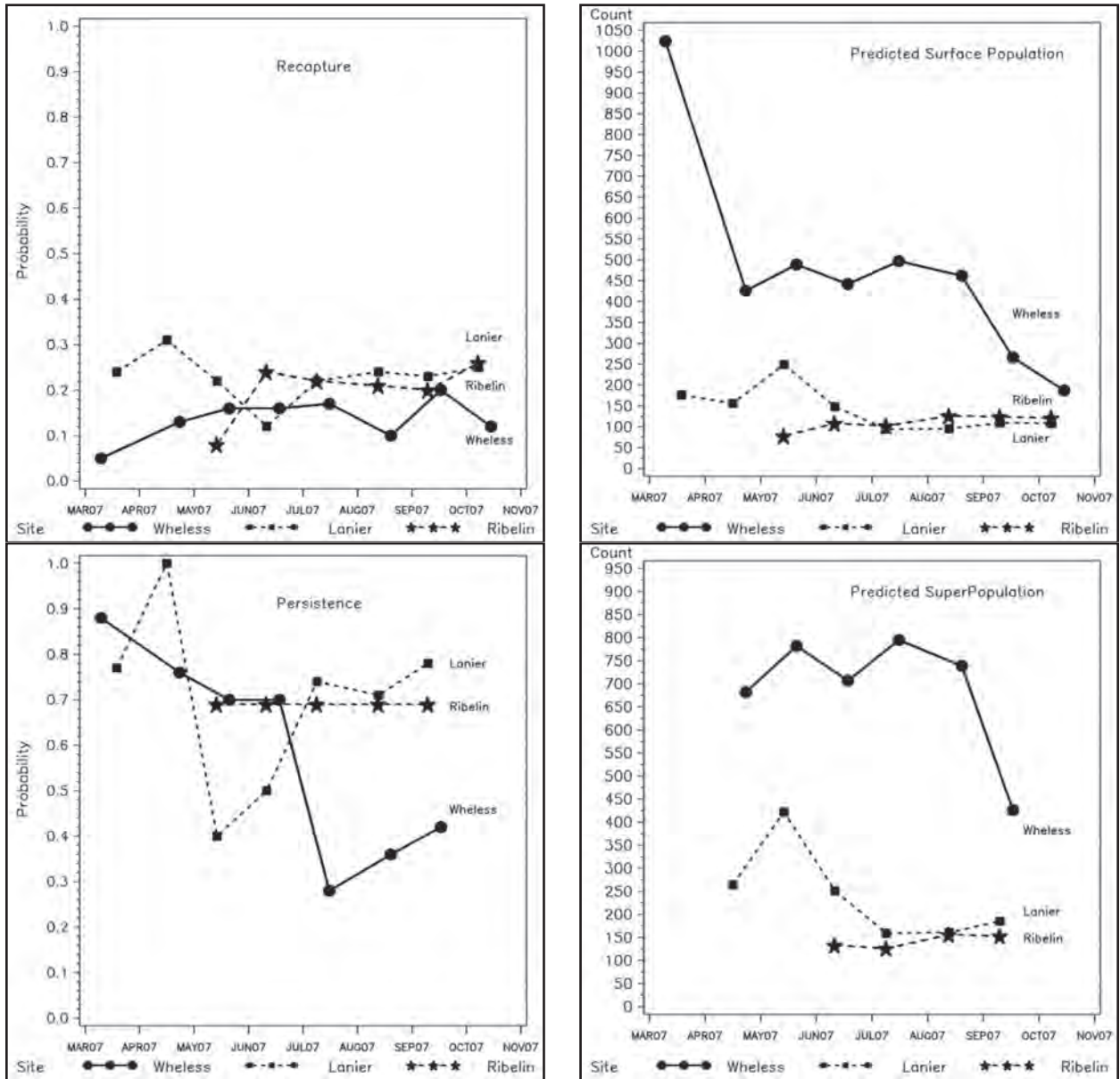

Figure 5: Estimated *Eurycea tonkawae* population parameters by month for Lanier Spring, Lower Ribelin, and Wheless Spring, 2007. Detection probabilities for the March primary period at Wheless Spring could not be estimated due to low number of recaptures and were fixed at 0.05, resulting in an unreliable estimate (1024) for the March surface population. Flows at Wheless Spring subsided in September, resulting in lower population estimates.

population size, it does highlight the ability of surface count surveys under ideal habitat conditions (e.g. continuous spring flows) to show a relatively consistent fraction of the total estimated population size on average across different sites over an extended study period. However, populations may respond differently over a longer period of time and under less than ideal conditions, particularly drought and habitat degradation. Thus, mark-recapture should continue at a subset of sampling sites to monitor changes in detection probabilities, adjust surface count data as needed, and gather other data that cannot be obtained from surface counts,

such as dispersal and longevity.

Acknowledgements

We would like to acknowledge the support of the many friends, colleagues, and partners that assisted with this project. The City of Austin provided funding, equipment, and staffing for this project. The Lower Colorado River Authority provided access to the Wheless property and field assistance. Environmental & Planning Associates, Inc. (Austin, Texas) granted access to the Ribelin Ranch preserve for monitoring. Robyn Smith provided logistical

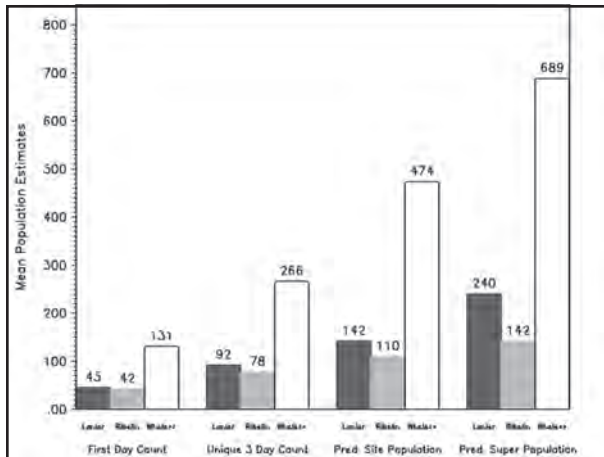

Figure 6: Mean first day count, primary period (3-day) unique captures, estimated total surface population, and estimated superpopulation for *Eurycea tonkawae* at Lanier Spring, Lower Ribelin, and Wheless Spring, 2007.

and moral support at a critical time when it was most needed. Robert Clayton produced the computer-generated list of 2500 unique color combinations and developed the Access database. Leah Gluesenkamp and Alisha Shah provided extensive QA/QC that ensured a high quality dataset. Larissa Bailey (USGS Patuxent Wildlife Research Center) provided guidance and advice on the data analyses. Additionally, this project would not have been possible without the dedication and support of an outstanding crew of field staff and volunteers.

References

- Amstrup, S., T. McDonald, and B. Manly (eds.) (2005) *Handbook of capture-recapture analysis*. Princeton University Press, Princeton, NJ, 296 p.
- Bailey, L. (2004) Evaluating elastomer marking and photo identification methods for terrestrial salamanders: marking effects and observer bias. *Herpetological Review* **35**, 38–41.
- Bailey, L., T. Simons, and K. Pollock (2004a) Estimating detection probability parameters for plethodon salamanders using the robust capture-recapture design. *Journal of Wildlife Management* **68**, 1–13.
- Bailey, L., T. Simons, and K. Pollock (2004b) Spatial and temporal variation in detection probability of plethodon salamanders using the robust capture-recapture design. *Journal of Wildlife Management* **68**, 14–24.
- Bailey, L., T. Simons, and K. Pollock (2004c) Comparing population size estimators for plethodontid salamanders. *Journal of Herpetology* **38**, 370–380.
- Doody, J. (1995) A photographic mark-recapture method for patterned amphibians. *Herpetological Review* **26**, 19–21.
- Gambel, L., S. Ravela, and K. McGarigal (2007) Multi-scale features for identifying individuals in large biological databases: an application of pattern recognition technology to the marbled salamander *Ambystoma opacum*. *Journal of Applied Ecology* **45**, 170–180.
- Heyer, W., M. Donnelly, R. McDiarmid, L. Hayek, and M. Foster (1994) *Measuring and monitoring biological diversity: standard methods for amphibians*. Smithsonian Institution Press, Washington D.C. 364 p.
- KENDALL, W. and R. BJORKLAND (2001) Using open robust design to estimate temporary emigration from capture-recapture data. *Biometrics* **57**, 1113–1122.
- Kendall, W. and J. Hines (1995) On the use of secondary capture-recapture samples to estimate temporary emigration and breeding proportions. *Journal of Applied Statistics* **22**, 751–762.
- Kendall, W., J. Nichols, and J. Hines (1997) Estimating temporary emigration using capture-recapture data with Pollock's robust design. *Ecology* **78**, 563–578.
- Loafman, P (1991) Identifying individual spotted salamanders by spot pattern. *Herpetological Review* **22**, 91–92.
- O'Donnell, L., M. Turner, M. Sanders, E. Geismar, S. Heilman, L. Zebehazy (2006) Summary of Jollyville Plateau salamander data (1997 – 2005) and status. City of Austin Report No. SR-07-02, 50 p.
- O'Donnell, L., A. Gluesenkamp, C. Herrington, M. Schlaepfer, M. Turner, and N. Bendik (2008) Estimation of Jollyville Plateau salamander (*Eurycea tonkawae*) populations using surface counts and mark-recapture. City of Austin, Austin Water Utility and Watershed Protection and Development Review Department, 110 p.

Smith, E. (2004) Population size and movements of spotted salamanders at South Holston Dam, Sullivan County, Tennessee. Unpub. Master's thesis. Department of Biology, East Tennessee State University. Johnson City, TN, 36 p.

Thompson, W (ed.) (2004) *Sampling rare or elusive species: concepts, designs, and techniques for estimating population parameters*. Island Press, Washington, D.C., 429 p.

BEHAVIORAL ECOLOGY OF AQUATIC SALAMANDERS COLONIZING SUBTERRANEAN HABITATS

JAKOB PARZEFALL

Biozentrum Grindel University of Hamburg, Martin Luther King Platz 3 D-20146 Hamburg Germany,
parzefall@zoologie.uni-hamburg.de

Members of three of the eight families of salamanders have colonized subterranean habitats successfully. They all show reductions of morphological structures. Eyes and skin pigments are reduced to varying degrees depending upon the phylogenetic age of cave colonization. For the behavior patterns that are normally driven by visual signals, the question arises of how cave dwellers compensate for this disadvantage in complete darkness. Many potential cave dwellers have already developed in the epigeal habitat the sense organs and behavior necessary to find food and to reproduce in darkness. They are preadapted with enhanced sense organs and acquire behaviors for their extreme habitat. In salamanders, the behavior patterns of only a few taxa have been studied in comparison to epigeal relatives.

One species that has been studied is *Proteus anguinus* of the dinaric karst in Slovenia and Croatia. It is blind and pale and searches for invertebrate prey using chemical and mechanical information. When compared with a young cave colonizer with fully developed eyes, the Pyrenean salamander (*Euproctus asper*), *P. anguinus* needs less time to react and to find living or dead prey in darkness and in light. All the species studied use chemical signals to communicate with conspecifics. Water transmission of chemical signals has been demonstrated for *Proteus anguinus*, *Euproctus asper* and *Eurycea* (formerly *Typhlomolge*) *rathbuni*, the Texas blind salamander. The information seems to be species specific, sex specific, and also specific to individuals. In addition, *Proteus* also constantly emits a chemical substance while in contact with the substrate and at communal resting places. This substance is specific to the individual but does not provide any detailed information about sex or reproductive state. For recognition of sex and reproductive state, *P. anguinus* requires direct contact. This is in contrast to *E. rathbuni* where only water borne signals give this type of information. Males and females find each other on the basis of these signals. They must synchronize their behavior in order to provide effective fertilization in the darkness. The reproductive behavior in *E. rathbuni* and *P. anguinus* is very similar. When a female ready to reproduce enters a territory, the male begins to send chemical information by fanning his tail in front of her. Then he walks away and the female follows and nips on the genital region of the male. After a short walk, the male deposits a spermatophore, which the female retrieves and places in her cloacal region. In *E. asper*, the male transfers the spermatophore during amplexus actively into the cloaca. The species studied defend territories. At least the male defends a small breeding territory, using an aggressive pattern against an intruder starting with tail movements. In case of a fight, tail-beating and biting are performed in close body contact. Typically the loser escapes and a submission posture has not been observed.

1. Introduction

Within the vertebrates, primarily teleost fishes have colonized caves successfully. The exact number of cavernicolous fishes is unknown and every year new ones will be described in different parts of the world. More than 104 teleost species, subspecies and populations restricted to caves were known as of 2003 (Proudlove, 2003). In some taxa the behavioral ecology of these cave dwelling fishes have been studied in detail (Parzefall, 1993). In contrast to the high number of cavernicolous fish, only a few salamander taxa (Table 1) have colonized caves. For some of them behavioral data exist which demonstrate the adaptation to

the dark habitat.

2. Food and Feeding Behavior

All the cave dwelling taxa studied feed on all types of invertebrates (*Euproctus*: Clerque-Gazeau, 1999; *Proteus*: Parzefall et al., 1999; *Speleomantes*: Lanza, 1999). In a comparative laboratory study with the eyed *Euproctus asper* and the blind *Proteus anguinus* both species reacted to living and dead chironomids in light and darkness. The movements of plastic dummies released searching behavior. Even in light, where *E. asper* can use their visual sense, *P. anguinus* required less time to initiate the first snapping

Proteidae <i>Proteus anguinus</i> Laurenti, 1768	eyes reduced, blind	Dinaric karst from Trieste, Italy in the northwest over Slovenia and Croatia to the Trebisnica River in Bosnia-Herzegovina in the southeast
<i>Proteus anguinus parkelj</i> Sket & Arntzen, 1994	small eyes	Near Crnomelj in the Bela Kraina, southern Slovenia
Plethodontidae <i>Eurycea tridentifera</i> Mitchell & Redell, 1965	eyes red.	caves in Cibolo sinkhole plain and adjacent regions, Comal and Bexar Counties, Edwards Plateau, Texas
<i>Eurycea latitans</i> Smith & Potter, 1946	small eyes	
<i>Eurycea troglodytes</i> Baker, 1957	eyes red.	
<i>Gyrinophilus gulolineatus</i> Brandon et al. 1986	eyes red.	caves at east bank of Tennessee River Valley, USA
<i>Gyrinophilus palleucus palleucus</i> McCrady, 1954	eyes red.	caves of southern Cumberland Plateau, southern Tennessee and northern Alabama, USA
<i>Gyrinophilus subterraneus</i> Beshars & Holsinger, 1977	eyes red.	General Davis Cave near Alderson, Greenbrier County, West Virginia, USA
<i>Haideotriton wallacei</i> Carr, 1939	eyes red, blind	Caves of Dougherty Plain of southwestern Georgia and adjacent northwestern Florida, USA
<i>Speleomantes</i> (= <i>Hydromantes</i>) species status unclear: since 1999 7 species before 1 or 2 species	eyes normal	mountain regions of southeast France, north and central Italy, island of Sardinia
<i>Eurycea rathbuni</i> Stejneger, 1896	eyes red, blind	San Marcos pool of Balcones Aquifer, Hays County, Texas, USA
<i>Eurycea robusta</i> Longley 1978	eyes red, blind	Balcones Aquifer to the north and east of Blanco River, Hays County, Texas, USA
<i>Eurycea spelaeus</i> Stejneger, 1892	eyes red, blind	southwestern Ozark Plateaus, southwest Missouri, southeast Kansas, northeast Oklahoma, northwest Arkansas, USA
Salamandridae <i>Euproctus asper</i> Dugès, 1852	eyes normal	in caves of the French Pyrenees

Table 1: Cave dwelling salamanders (from CLERGUE-GAZEAU, 1999; DURAND, 2005; LANZA, 1999; PARZEFALL et al.1999; WEBER, 2005).

response to dead prey. When the time between the start of an experiment and the first snap at prey was divided into pre-approach and approach phases, it turned out that the difference found could be attributed to the pre-approach phase (Fig 1). Living prey was detected more quickly than dead prey in both species, but *E. asper* needed more time in the darkness than did *P. anguinus* (Fig. 1,b,c). So *E. asper* seems less adapted to the dark but is capable of foraging successfully in both epigeal and hypogean habitats. Compensation for the unpredictability of food quality and quantity also results in physiological adaptations. Cave salamanders are able to survive long periods without food

– up to several years in *Proteus* (Vandel, 1964).

3. Reproductive Behavior

Males and females use water born chemical signals to find each other. This has been shown for *Proteus anguinus*, *Eurycea rathbuni* and *Euproctus asper*. Comparative studies with the epigeal proteid *Necturus maculosus* demonstrated that this information is species specific (Parzefall et al.,1980). For the recognition of sex and reproductive state *P. anguinus* needs direct contact. In tests with *E. rathbuni* the water-borne signals transmitted sex-specific information: adult males and juveniles showed a positive

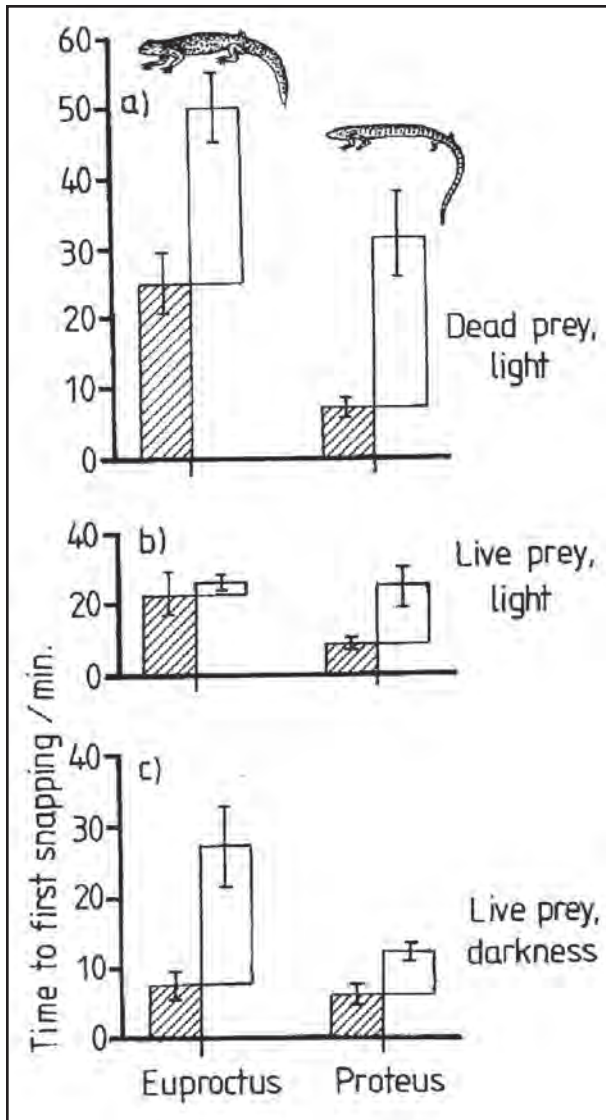

Figure 1: Snapping response in *Euproctus asper* and *Proteus anguinus*. The mean time interval between the start of the experiments and the first snap at prey was divided into a pre-approach phase (hatched bars) and an approach phase (open bars) in the three different experimental treatments. Standard errors of the mean are shown on top of the bars (after UIBLEIN et al. 1992).

response to water from females, but females showed avoidance of conspecifics (Bechler, 1986). *P. anguinus* also constantly emits a chemical substance while in contact with the substrate and at communal resting places. This substance is specific to the individual but does not provide any detailed information about sex or reproductive state; it merely brings members of the species together. Bechler (1986) was not able to show this phenomenon in tests with *E. rathbuni*. *E. asper* on the other hand prefers in choice tests tiles that previously had been used as hiding places by conspecifics (Parzefall et al., 1980). The reproductive

behavior in *Eurycea rathbuni* and *Proteus anguinus* is very similar. When a female ready to reproduce enters a territory, the male begins to send chemical information by fanning his tail in front of her. Then he walks away and the female follows and nips on the genital region of the male. After a short walk, the male deposits a spermatophore, which the female retrieves and places in her cloacal region (Bechler, 1988). In *E. asper* the male actively searches for the female or attracts females by chemical and visual signals; mainly a tail-up position, which we successfully tested with dummies (Fig. 2). Then it transfers the spermatophore during an amplexus actively into the cloaca (Theismeyer and Hornburg, 1990; Lengvenus and Parzefall, 1992). Females deposit and then guard the eggs. This has been described for *E. asper* (Clerque-Gazeau, 1999), *Speleomantes ambrosii* (Durand, 1970) and *P. anguinus* (Durand et al., 1983). In a series of tests, Durand et al. (1983) showed that adult and subadult conspecifics avoid water coming from the eggs (Fig. 3). Females, on the other hand are attracted by the chemical information of their own eggs. Unfortunately we have insufficient data of closely related epigeal species like the Proteid *Necturus maculosus* to understand the degree of adaptation in the cave forms concerning this behavior patterns.

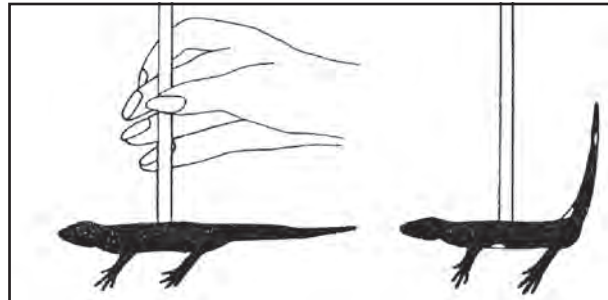

Figure 2: Dummies of *Euproctus asper* males in normal position and with lifted tail (after LENGVENUS and PARZEFALL, 1992).

4. Aggressive Behavior

Aggressive behaviour consists of different patterns: threatening postures and attacks followed by fights. The threatening animal in general enlarges his body shape, shows striking colors. During encounters, aggressive behaviours include biting, striking or beating the opponent. To perform such a complex behavior, visual orientation is of great importance. Therefore the question arises whether the cave forms in darkness reduce the whole system or only part of it. The study of this behavior under cave conditions in *E. asper* (Lengvenus and Parzefall, 1992), *P. anguinus* (Parzefall, 2000) and *E. rathbuni* (Bechler, 1986) reveals that in the three taxa territorial behavior still exists.

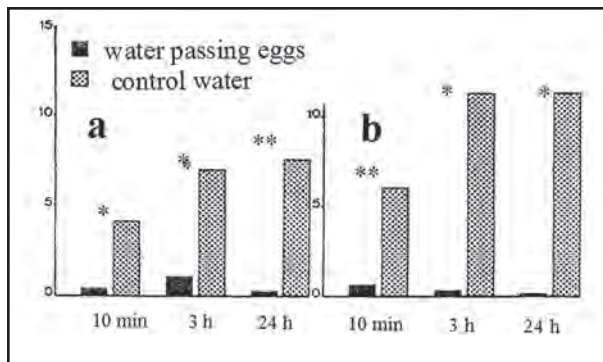

Figure 3: Choice test with *Proteus anguinus*. Animals can enter a tube offering a water current of an aquarium with an egg-clutch or of an empty aquarium. a) the time in minutes of subadults resting in one of the tubes 10 minutes, 3 hours and 24 hours after the start of the experiment. $n=13$. b) the same reaction of adults. $n=14$. * $p<0,01$, ** $p<0,02$. (after DURAND et al., 1983).

However, threatening postures are reduced and the existing patterns like tail beating, ramming and biting occur in close proximity or with body contact without the necessity of visual signals.

5. Conclusions

The behavioral data on the cave dwelling salamanders studied demonstrate the importance of chemical and tactile signals in all functional aspects. In far field communication, waterborne signals are used. In near field water, waves and chemical signals transmitted in close body contact are important. In addition chemical signals secreted to the substrate help the animals to find each other in the dark habitat. All these signals seem already present in the epigeal relatives. So they are preadapted in their behavioural repertoire and need not to develop new behavioural patterns for their life in darkness.

Acknowledgement: The paper is dedicated to the famous French biospeleologist and close friend J.P. Durand, who died in April 2007

References

- BECHLER, D.L. (1986) Pheromonal and tactile communication in the subterranean salamander *Typhlomolge rathbuni*. *Proceedings of the 9th International Congress of Speleology*, Barcelona, p. 120–122.
- BECHLER, D.L. (1988) Courtship behavior and spermatophore deposition by the subterranean salamander *Typhlomolge rathbuni* (Caudata, Plethodontidae). *The Southwestern Naturalist* **33**,

124–126.

- Clergue-Gazeau (1999) *Euproctus asper* – Pyrenäen-Gebirgsmolch. Chap.4 *Handbuch der Reptilien und Amphibien Europas*, Kurt Grossenbacher und Burkhard Thiesmeier (Eds), Aula Verlag Wiesbaden, Band 4/1, p. 251–270.
- DURAND, J.P. (1970) Fortpflanzung und Entwicklung von *Hydromantes*, dem Höhlenmolch. *Aqua Terra* **7**, 42–51.
- Durand, J.P. (2005) Salamanders. in *Encyclopedia of Caves*, David C. Culver and William B. White (Eds). Elsevier, New York, p. 485–491.
- DURAND, J.P., M. BOUILLON, and J. PARZEFALL (1983) Réponse de *Proteus anguinus* L., amphibiens cavernicole, à des stimuli chimiques provenant de la ponte. *Mémoires de Biospéléologie*, **10**, 395–399.
- Lanza, B. (1999) *Speleomantes*-Europäische Höhlensalamander. Chap.3 in *Handbuch der Reptilien und Amphibien Europas*, Kurt Grossenbacher und Burkhard Thiesmeier (Eds), Aula Verlag Wiesbaden, Band 4/1, p. 81–204.
- LENGVENUS, W., and J.P. PARZEFALL (1992) The role of visual reaction in the behaviour of an epigeal and a cave living population of *Euproctus asper* DUGES (Salamandridae, Urodela). *Mémoires de Biospéléologie* **19**, 111–115.
- Parzefall, J. (2000) Ecological role of aggressiveness in the dark. Chap. 11 in *Subterranean Ecosystems* Horst Wilkens, David C. Culver, William F. Humphries (Eds), Elsevier, Amsterdam, New York, p. 221–228.
- Parzefall, J. (1993) Behavioural ecology of cave-dwelling fishes. Chap. 17 in *Behaviour of Teleost fishes*. Tony J. Pitcher (Ed.), Chapman & Hall, London, p. 573–606.
- Parzefall, J., J. P. Durand, and B. Sket (1999) *Proteus anguinus* - Grottenolm. Chap.2 in *Handbuch der Reptilien und Amphibien Europas*, Kurt Grossenbacher und Burkhard Thiesmeier (Eds), Aula Verlag Wiesbaden, Band 4/1, p. 57–76.
- PARZEFALL, J., J.P. DURAND, and B. RICHARD

(1980) Chemical communication in *Necturus maculosus* and his cave-living relative *Proteus anguinus* (Proteidae, Urodela). *Zeitschrift für Tierpsychologie* **53**, 133–138.

Proudlove, G. (2003) *Subterranean Fishes of the World*. International Society for Subterranean Biology, Moulis, France. 300 p.

THIESMEIER, B., und HORNEBURG (1990) Zur Fortpflanzung sowie zum Paarungsverhalten der Gebirgsmolche, Gattung *Euproctus* (Genè), im Terrarium, unter besonderer Berücksichtigung von *Euproctus asper* (Dugès). *Salamandra* **26**, 63–82.

UIBLEIN, F., J.P. DURAND, C. JUBERTHIE, and J. PARZEFALL (1992) Predation in caves: effects of prey immobility and darkness in the foraging behavior of two salamanders, *Euproctus asper* and *Proteus anguinus*. *Behavioural Processes* **28**, 33–40.

Vandel, A. (1964) *La Biologie des Animaux Cavernicoles*. Gauthier-Villars, Paris, France 300 p.

WEBER, A. (2000) Fish and Amphibia. Chap. 6 in *Subterranean Ecosystems* Horst Wilkens, David C. Culver, William F. Humphries (Eds), Elsevier, Amsterdam, New York, p.109–132.

Symposium 4

FRONTIERS IN CAVE MINERALOGY STUDIES

Arranged by:
Bogdan P. Onac
Carol A. Hill

CRYOMINERAL FORMATIONS FROM KOUNGUR ICE CAVE (RUSSIA)

VIACHESLAV N. ANDREYCHOUK

University of Silesia, Faculty of Earth Sciences, Będzińska 60, 41-200 Sosnowiec, Poland

Cave mineralogy problems have been widely described in the literature (HILL AND FORTI, 1997). However, there are some „gaps” in this knowledge. One of them is *mineralogy of cave ice*, the question about minerals (salts, admixtures) present in ice, their origin (cryoninerogenesis), morphology, etc. The ideal objects for such investigations are ice caves containing long-lasting/permanent ice formations. During the infiltration of water (with high TDS content) into caves and during its freezing, the process of crystallization of different minerals (cryominerals) in the freezing water occurs. The author carried out detailed cryomineralogical investigations in Koungur Ice Cave, Ural Mountains (Russia). The investigations of the cryomineral material from ice covers using SEM revealed that during freezing (crystallisation) of ice in the contracting structural cells between the ice crystals the following minerals crystallize: gypsum (96-99% of volume mass), celestine (1-5%), calcite (1-3%) and quartz (<1%). The crystals of all minerals are well developed and show specific crystallographic forms. During ice melting or evaporation (sublimation), its mineral components “get free” and deposit at the foot of underground covers creating considerably thick (10-20cm) layers and conglomerations of white powder similar to flour. Under the influence of humid air, a secondary crystallization of flour deposit occurs and mineral aggregates develop.

1. Introduction

The Mineralogy of cave ice has been poorly investigated. There are not so many publications on this subject (ANDREYCHOUK, 1989; ANDREYCHOUK et al., 2001, 2004, 2005; ZÁK et al., 2006). Despite the fact it is a very detailed subject such studies are of great importance. New mineral formations in ice genetically connected with cryochemical processes have not been thoroughly investigated. Cave ice, compare to surface ice

forms, are enriched with mineral components (up to 1-2 g/l) and therefore are the objects of great potential in scientific investigations. When melting, underground ice releases various types of cave sediments, which obviously become interesting from the sedimentological point of view. Finding mineral forms with cryogenic features might enable researchers to carry on palaeoglaciological reconstructions; i.e. determining if underground glaciation occurred in a cave or not.

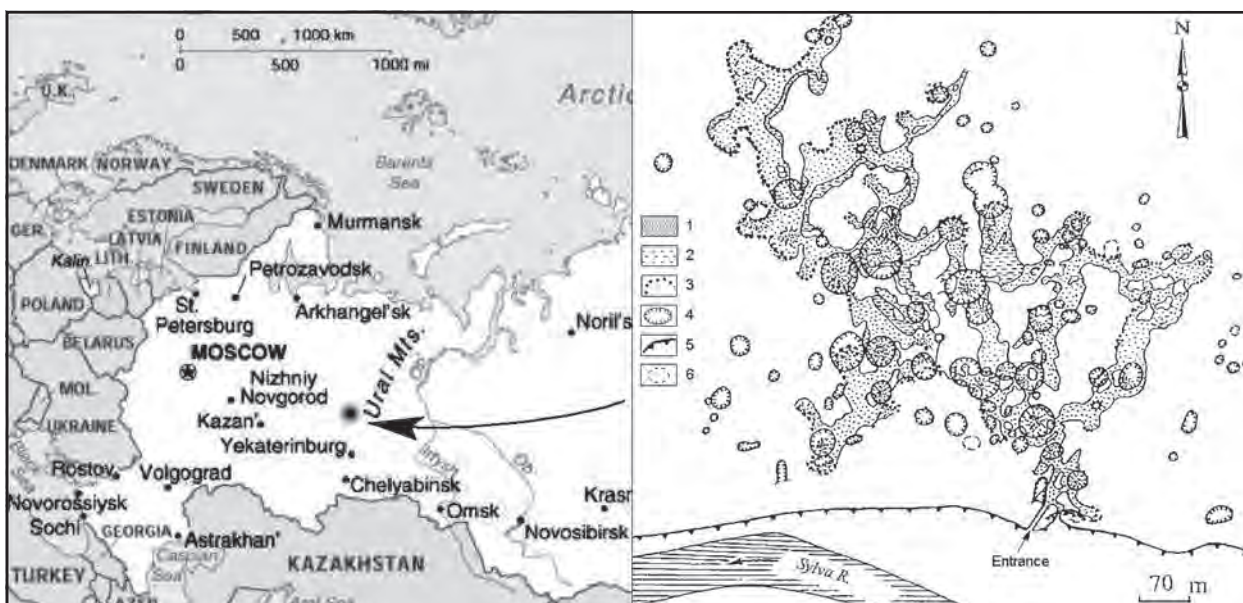

Figure 1: Location of the Koungur Ice Cave and main elements of its underground space: 1, cave space, 2, underground lakes, 3, debris walls and cones, 4, sinkholes, 5, edge of Sylva River Valley, 6, depression of subsidence.

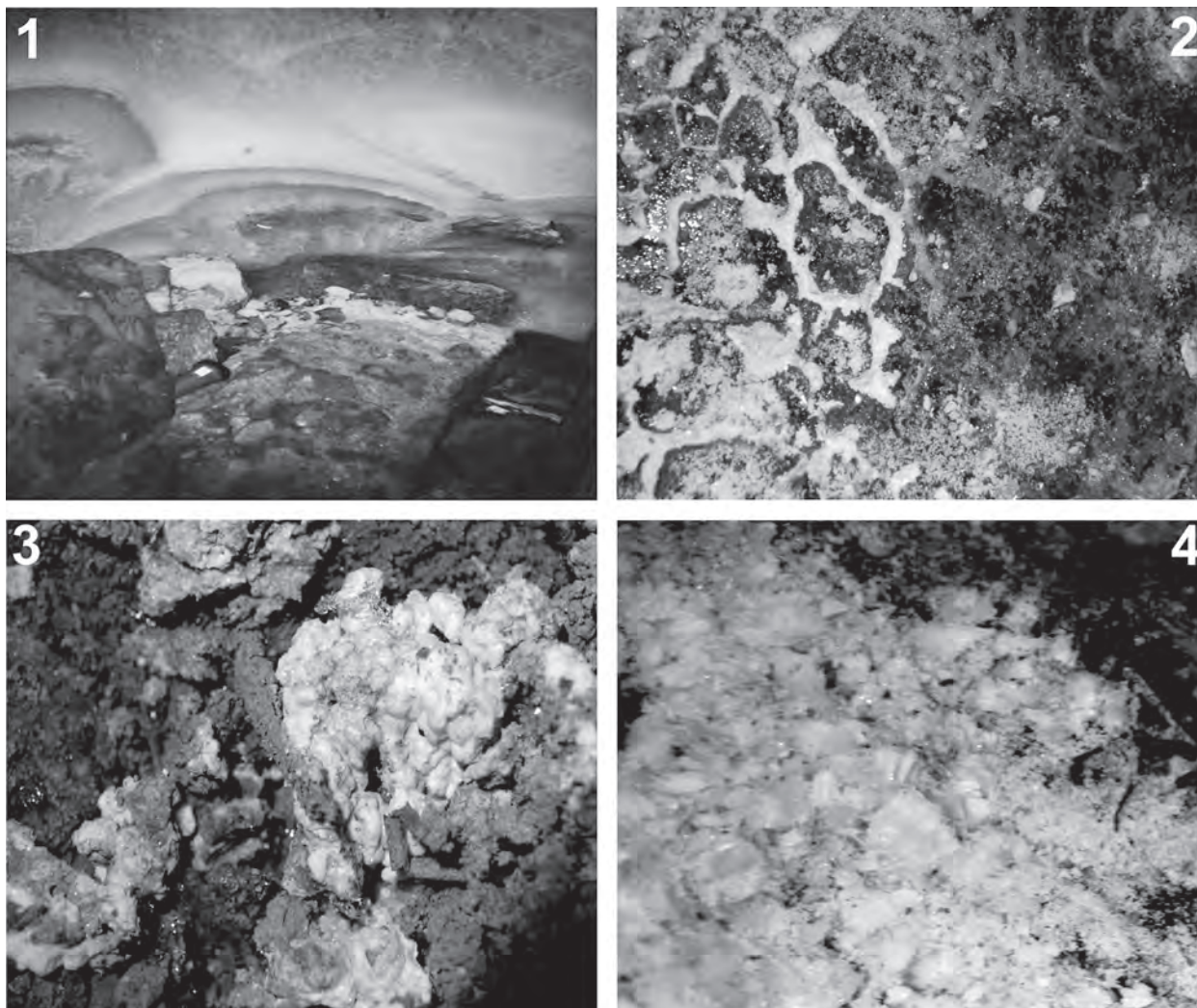

Figure 2: Gypsum powder forms: 1, accumulation of powder under the naled ice between Diamond and Polar Caves, 2, powder remnants on the spot of the melted seasonal ice form, 3, initial aggregation (sticking and crystallization) of cryogenic “remnants,” 4, gypsum crystals growing from the cryogenic gypsum material (1, photo V. Andreychouk, 2–4, O. Kadebskaya).

The goal of this work was to find at least partial answers concerning the origin of formation of *mineral (gypsum, calcite) flour*; i.e., a typical cryochemical form occurring in gypsum, but also in caves in carbonate rocks. Samples of powder from one of the most famous caves, Kougur Ice Cave, have been analysed.

2. Gypsum flour in Kougur Ice Cave

Kougur Ice Cave is located in the Pre-Ural (Russia) (Fig. 1). It is developed in a 90 m thick layer of sulfates (evaporates) of the Permian age. It is a labyrinth formed by a number of halls connected by narrower galleries. The total length of the cave totals 5.6 km and its volume is 350,000 m³.

Kougur Ice Cave is famous for its ice speleothems – stalactites, stalagmites, ice covers, underground glaciers

(perennial ice), hoarfrost crystals, and ice lakes. Speleothems in ice caves are of various origins: *atmogenic* (ice sublimation – cave hoarfrost, ice rind, ice cover composed of ice crystals and crystallised snow), *hydrogenic* (ice stalactites, stalagmites, stalagnates (pillars), rind and ice covers and ice lakes) and *heterogenic* (mixed ones) (MAKSIMOVICH, 1947). Mineralization and chemical content of the ice strongly depends on its genetic type. The highest (985–1407 mg/l) mineralization occurs in ice of hydrogenic origin. White powder occurs frequently on the surface of such ice forms in gypsum caves. It often concentrates at the base of the forms (Fig. 2-1) where it is called “gypsum flour” (FEDOROV, 1883; KARAKASH, 1905). These flour-like sediments accumulate especially in melt hollows and can reach a maximum thickness of 0.5 – 10.0 cm. However, the thickness of this powder on the surface of

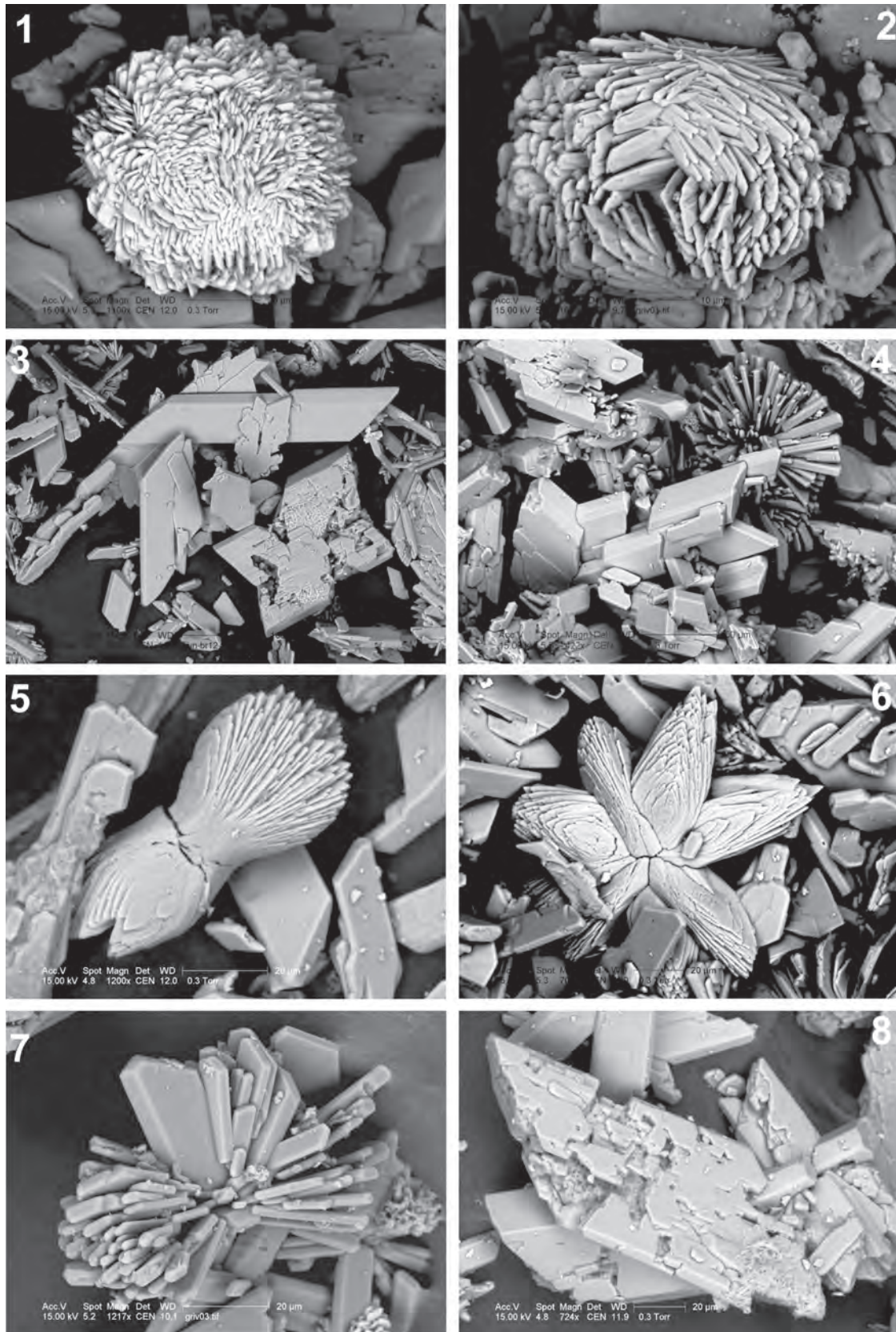

Figure 3: Morphology of crystal aggregates: 1–2, split spherulitic aggregates of celestine, 3–4, tabular and platy gypsum crystals, 5–6, rose-like and sheaf-like calcite crystals, 7, spherulitic gypsum crystal aggregates, 8, skeletal gypsum crystals.

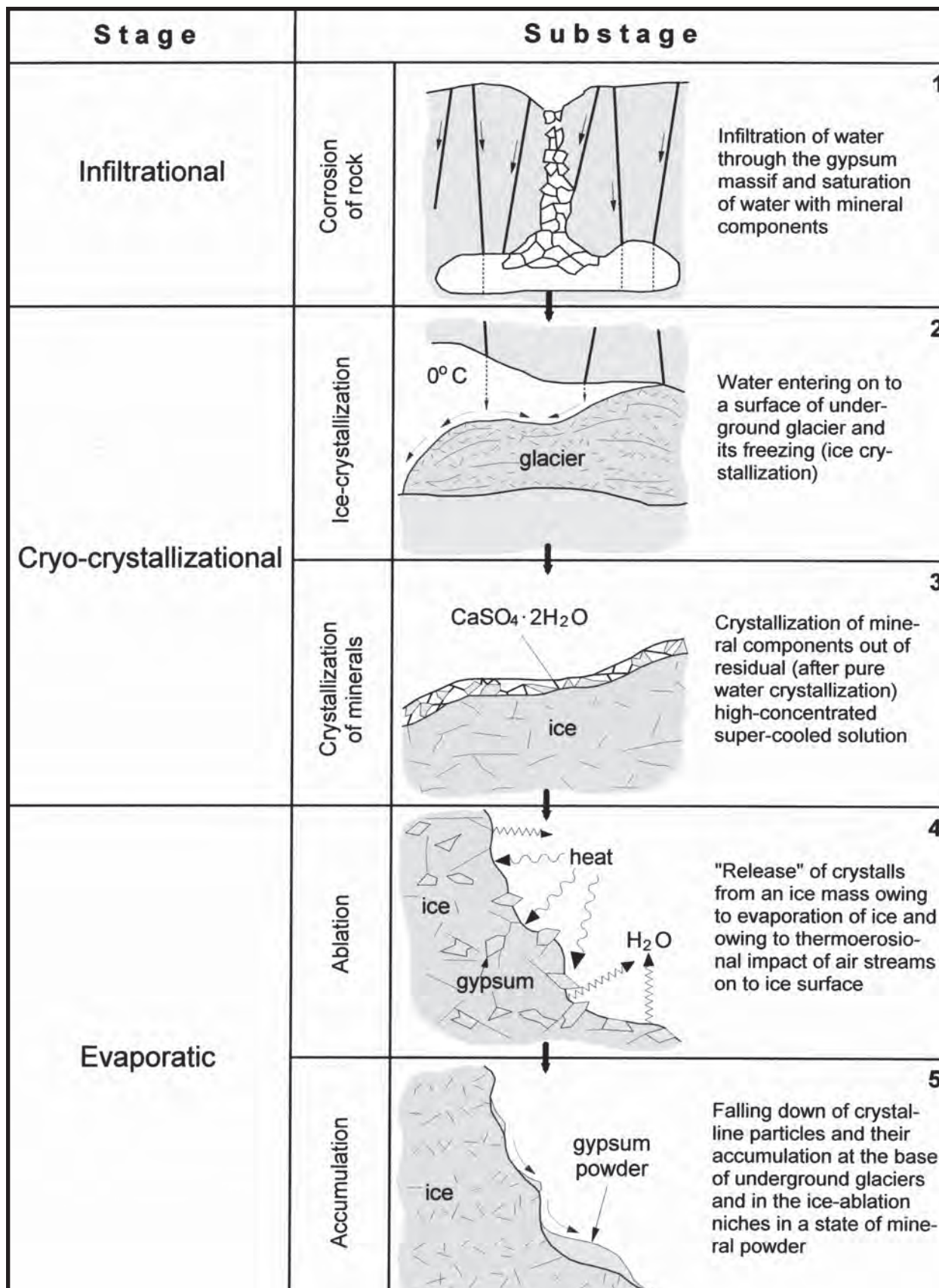

Figure 4. Main stages of formation of crychochemical gypsum powder under perennial ice in Koungur Cave (figures illustrating stages in different scales).

stalactites, stalagmites, or ice rinds does not exceed 1 mm (ANDREYCHOUK, 1989). The flour powder occurs also in the areas where seasonal ice forms melt. Together with the rest of melt water it forms a kind of gypsum “dough” (Fig. 2-2). The mass dries due to evaporation and then gypsum crystallization can start (Fig. 2-3). In such cases, various aggregates of gypsum crystals may form (Fig. 2-4). As the process continues through different stages, there is a regular tendency to form larger crystals.

3. Morphology of Cryocrystals from the Cave Ice

Detailed analysis of the powder has confirmed its gypsum content: 97–99% of gypsum, 1–3% - calcite, 1–5% - celestine. Morphology of the gypsum, calcite, and celestine crystals was r. E. GALUSKIN). Mineral diagnostics has been confirmed by x-ray structural examination.

Celestine occurs as rhombic simple form crystals: pinacoid {001}, rhombic prisms {011}, {102}, {110} and a rhombic dipyrmaid {111}? (Fig. 3-1, 3-2). *Gypsum* crystals occur in three similar forms: pinacoid – {010}, Rhombic prisms – {120} и {-111} and secondary ones – {011}, {-101} (Fig. 3-3, 3-4). *Calcite* is in the form of acute rhombohedron {04-41} (Fig. 3-5, 3-6), which is characteristic for minerals with high contents of sulfate ions (KIRIANOVA et al., 1998).

Numerous simple forms of gypsum, calcite, and celestine appearing on the surface of crystals of various origin, according to KIROV et al. (1997), do not provide any crucial genetic information. On the other hand, *morphology of aggregates* and *microrelief of edges* show specific features that of conditions and mechanisms for cryogenic minerals. Various cleaved forms from *sheaf-like* and *rose-like* aggregates to *spherulite* ones, shown in (fig. 3-7) seem to be the main morphological feature of all minerals. Cleavage is the result of the auto deformation mechanism, connected with occurrence of heterometry on the borders of the crystal growth sectors (PUNIN et al., 1991), and it occurs during formation of crystals under the *chemical supersaturation regime*.

Skeletal, block-type growth with inductive elements is common among gypsum crystals. It may suggest that the gypsum and ice crystals grow together. Gypsum and ice paragenesis appear in the form of a great number of hollows in skeletal crystals of gypsum being the result of ice melting (Fig. 3-8). Skeletal and cleaved forms appear also as non-homogenous forms around growing gypsum crystals, caused by separate feeding of different parts of crystals and generally high speed of crystal. Celestine and calcite appear in significantly smaller amounts in the powder. Their crystallization is connected with oversaturation of the

solution in freezing ice cells.

4. Formation of Gypsum Powder

Results of observations on the mechanism of underground ice formation, and also morphological features of crystals in the gypsum powder, enable a determination of the following formation scheme for specific types of *cave ice forms* (Fig. 4).

Percolation of precipitation and underground water through the gypsum-anhydrite massif (infiltration) is the main factor of the process. At that stage (Fig. 4-1) poorly mineralized aggressive water (less than 300-500 mg/l) intensively dissolves sulfate rocks, saturating up to 800-1900 mg/l so as to get a substantial sulfate-lime content. Despite high mineralization of the infiltrating water it remains undersaturated with respect to gypsum. In the entrance part of the cave containing ice, infiltrating water drops and flows over surfaces, thus cooling freezing; layer-by-layer, it increases the thickness of small underground glaciers. The process of accumulation is particularly intensive during colder parts of the year, when the cave becomes cooler and moisture is supplied with “warm” mineralized (not freezing) percolating water from the upper parts of gypsum massif (Fig. 4-2).

Freezing of sulfate water does not occur fast (due to high contents of dissolved salts) but gradually. The process of ice crystallization is accompanied by increase of salt concentration in the final solution, where crystallization of gypsum and further calcite and celestine occurs. Degassing of CO₂-rich solutions plays an important role in the crystallization of calcite because it lowers its carbonate capacity.

Therefore, the crystallization of gypsum, calcite, and celestine (in *cryo-crystallization stages*) occurs in the process of sulfate-lime water freezing from the *final highly mineralized solutions*. Particles of these minerals in the form of crystals may remain in the ice for very long time (Fig. 4-3). It is hard to say anything about the morphological change stay in the ice. Such changes might occur because of dynamic changes of environment in underground ice (changes of temperature, glacier mass, etc.), thus initiating recrystallization of the ice.

Release of mineral particles from the ice body and their accumulation occurs mainly during the process of underground ice sublimation (*evaporation stages*). In winter, due to more humid more humid conditions of the cave and external air (mostly cold and dry), ice evaporates and white gypsum microcrystals remain on its surface in the form of a white powder (Fig. 4-4). The powder accumulates either in

ice notches or at the foot of underground glaciers (Fig. 2-1, Fig. 4-5).

5. Conclusions

Mineralogical investigations prove the cryogenic origin of mineral powders in Kungour Ice Cave. They contain gypsum crystals and smaller amount of celestine and calcite crystallizing from *oversaturated* crystallization processes, which occur (or are the most active) in the cold part of a year, mostly at the end of autumn and the beginning of winter.

Occurrence of fine powder on the surface of ice, stalactites, and stalagmites, etc. is connected with release (during ice evaporation) of microscopic crystals of minerals from the ice mass in the form of cryogenic powder and its accumulation at the foot of ice deposit or on speleothems.

Previous investigations, along with this research, prove that cryogenic processes and its associated formation of minerals is very common in caves and also in fissures and hollows of the temperate zone and in high mountains. Naturally, the processes are even more active in cold areas, in subpolar and polar zones. As a result of cryogenetic "sedimentation" a significant part of the minerals dissolved in water is deposited on the walls and floors of ice caves thereby enriching cave sediments with carbonate and sulfate components and also thereby participating in further speleominerogenesis.

The amount of sulfates and carbonates "defrosted" from karst water in cold areas is hard to estimate. However, it maybe necessary to investigate other karst-related processes; for example, low-intensity karst denudation in cold regions. Finally it should be considered that part of the material is removed from caves by rivers, which decreases the amount of material left in caves and fissures. That means that chemical denudation in polar and high mountain regions may lower the surface substantially. By how much? Further investigations may give the answer.

References

- ANDREYCHOUK, V. (1989) Nekotoryye svoyeobraznyye otlozheniya v Kungurskoy peschere, svyazannyye s ee oledeneniyem. *Proceedings of the Conference Mineraly i otlozheniya peshcher i ich prakticheskoye znacheniyey*, Perm, pp 22–23 (in Russian).
- ANDREYCHOUK, V. and E. Galuskin (2001) Kriogennyye mineralnyye obrazovaniya Kungurskoy Ledyanoy peshchery. *Peshchery* 27-28, Perm, pp108–116 (in Russian).
- ANDREYCHOUK, V., E. Galuskin, and B. Ridush (2004) Kriogenni mineralni utvorenniya z gipsovykh pecher Bukovyny. *Naukovy visnyk Cherniveckoho universytetu*, 220, *Geografia*, pp24–42 (in Ukrainian).
- ANDREYCHOUK, V., E. Galuskin, and B. Ridush (2004) Cryomineral formations from North Bukovinian Caves. *Ist International Workshop on Ice Caves: Volume of abstracts*, pp36–37.
- ANDREYCHOUK V., E. Galuskin, and A. Perşoiu (2005) Cryomineral formations of Scărișoara Cave (Romania). *Glacier cave and Glacial Karst in High Mountains and Polar Regions. Russian Academy of Sciences, Institute of Geography*, Moscow, pp 85–86.
- FEDOROV, E.S. (1883) Zаметка о Kungurskikh peshcherach. *Materialy dlya geologii Rossii*, 11, 217–243.
- HILL, C., and P. Forti (1997) *Cave minerals of the world (2nd edition)*. Huntsville, USA, 463 pp.
- KARAKASH, N.E. (1905) Kungurskaya ledyanaya peshchera na Urale. *Tr. SPb. Obsb. Yestestv*, 36, Moscow, pp11–24 (in Russian).
- KIROV, G.-K., I. Vesselinov, and Z. Cherneva (1972) Condition of formation of calcite crystals of tabular and acute rhombohedral habit, *Kristall. Udn Technik*, pp 497–509.
- KIRYANOVA, E.B., V.G Krivovichev, and A.E. Glikin (1998) Geneticheskaya kristallomorfologiya kalcita (po eksperimentalnym I prirodnyim dannym). *EVMO* 6, pp16–21 (in Russian).
- MAXIMOVICH, G.A. (1947) Peshchernyye ldy. *Izvestiya Vses. Geogr. Ob-va* 5, 537–549 (in Russian).
- PUNIN, Y.O, A.G. Shtukenberg, E.V. Churakova, and O.E. Artamonova (1991) Deformacionno-rostovoj mekhanizm dvojnikovaniya sufata kaliya. *Rost kristallov*, Kalinin, pp 36–46 (in Russian).
- ŽÁK, K., J. Urban, V. Cilek, and H. Hercman (2004) Cryogenic cave calcite from several Central European caves: age, carbon and oxygen isotopes and a genetic model. *Chemical Geology* 206, pp 119–136.

THE NAICA PROJECT

TULLIO BERNABEI^{1,4}, GIUSEPPE CASAGRANDE^{1,4}, ALICIA DAVILA^{1,4}, ANTONIO DE VIVO^{1,4}, ANTONIETA FERREIRA^{2,4}, GIUSEPPE GIOVINE^{1,4}, GONZALO INFANTE^{3,4}, FRANCESCO LO MASTRO^{1,4}

¹*La Venta – Esplorazioni Geografiche, info@laventa.it & Proyecto Naica*

²*Speleoresearch&Films & Proyecto Naica*

³*C/Producciones*

⁴*Proyecto Naica*

Naica is a typical mining center in the state of Chihuahua, northern Mexico. The history of Naica is strictly connected to its mining activity, dating back to the end of the 18th Century. Since 1998, the mine has been property of the Compañía Minera Peñoles. The mine produces silver (second most productive in Mexico), gold, lead, zinc, and copper.

In 1910, at a depth of 120 m, some miners discovered an 80-meter-long cave covered with 2-meter-long selenite crystals, Cueva de las Espadas. In April 2000, the brothers Eloy and Francisco Javier Delgado, during an excavation at the depth of 300 m, discovered Ojo de la Reina, a small cave with big crystals. A few days later, the miners discovered Cueva de los Cristales, hosting giant selenite crystals. The environmental conditions were extreme (almost 50° C, 100% humidity) and the survival time did not exceed a few minutes.

In January 2001, a first visit to the cave was carried out by Carlos Lazcano, Claude Chabert, Enrique Alejandri Escoto, and Carlos Valles Carrillo. In May and October 2002, La Venta carried out two missions, reaching the bottom of the chamber filming and shooting photos. In the period 2004-2006, La Venta studied and produced specific equipment and exploration protocols for the cave's extreme environmental conditions, which may be summarized into: refrigerated suits, refrigerated breathers (heat exchangers), communication devices, medical support and protocols, logistical support, and rescue protocols. In 2006, a joint agreement for the study and documentation of the cave was signed by La Venta with Speleoresearch&Films, C/Producciones, and Peñoles Mining Company. Speleoresearch&Films takes care of the general coordination, C/Producciones of documentation, and La Venta of research, exploration, and mapping.

The Naica Project aims at understanding the origin and age of the crystals, the relationship between the ore deposits and the crystals, the speleogenetic evolution of the caves, the presence of speleothems other than the gypsum crystals, the impact of human activity, the consequences on the human organism, the possible future evolution of the caves, and the possibilities of conservation.

In order to carry out the Project, a complete scientific panel has been organized and implemented. Several universities and researchers from different countries are now involved in the project.

1. The Naica Mine

Naica is a small mining town located on the gentle-relief slopes in the northern Mexican state of Chihuahua, 130 km south-east of the state capitol. According to local tradition, Naica means “place without water” but it is much more likely that the term is of Tarahumara origin, coming from the roots Rarámuri “Nai” (place) and “ka” (shadow), meaning “shadowy place,” as justified by the shadow projected from the isolated mountain range onto the surrounding desert. The history of Naica, apart from

the presence of the native Apaches between the 16th and 19th Centuries, is substantially tied to the growth of the mining industry, today world famous and carried out by the Mexican company Peñoles. The presence of minerals in Naica was discovered in 1794, when “*una mina ubicada en tierra virgen con el nombre de San José del Sacramento, en la Cañada del Aguaje de la sierra de Naica*” was registered. The exploitation of the poly-sulfide deposits (silver, zinc and lead) only began in 1900 and continues today, under the Peñoles mining company, in what is one of the most

productive mines in Mexico. The Naica mine opens on the northwest side of a dome-shaped structure that rises suddenly from the surrounding desert plain. It is 12 km long and 7 km wide, oriented northwest-southeast and displays secondary folding, faults and signs of erosion. This structure, known as the Naica Sierra, has an average altitude of 1,700 m a.s.l. and consists almost entirely of limestone rock. The Naica Mountain range presents a system of faults and fractures, formed prior to the mineralization, that run parallel to the main axis of the dome, oriented northwest-southeast and dipping southwest until reaching verticality. Along this system of fractures are located the main sulfide veins as well as the four known caves (Espadas, Ojo de la Reina, Velas and Cristales), which lack natural entrances and can be compared to deep geodes. The elevation of the plain surrounding the Naica Mountain range is approximately 1250 m a.s.l., while the entrance of the mine (Rampa San Francisco) is at 1385 m asl. From here on, the “depths” are given relative to this altitude. Inside, one reaches the water table at -120 m, therefore approximately at the altitude of the plain. The pumping that was carried out in order to allow the mining activity in the past decades has lowered this level to the current -850 m, emptying, among others, the Cueva de los Cristales, which is thought to have remained flooded by thermal water until about fifteen years ago. Currently, slightly less than a cubic meter of water per second is pumped out, which in the deeper zones has a temperature of 54° C.

2. The Discovery of the Naica Macro-Geodes

As early as 1910, a cave was found in the Naica mine at a depth of 120 m. It had a length of approximately 80 m and its walls were entirely covered by selenite crystals up to 2 m long. The crystals bore a similarity to sword blades, and so the cavity was named “Cueva de las Espadas” (Cave of the Swords).

In April 2000, the Eloy brothers and Francisco Javier Delgado, miners who were digging an exploratory tunnel at the depth of 300 m, intersected a very small passage in the rock. Francisco entered with difficulty and emerged into a cavern with a diameter of approximately 8 m, similar to a geode, full of selenite crystals similar to those of the Cueva de las Espadas but much larger and more spectacular; the cavity was named “Ojo de la Reina” (Eye of the Queen). The brothers, fascinated by the discovery, suspended the digging and informed the mine’s director, engineer Roberto González Rodríguez, who ordered that work on the tunnel be continued in a different direction in order not to damage the crystals. A few days later, a new chamber with a diameter of approximately 30 m was discovered, containing selenite mega-crystals up to more than ten

meters long and over one meter thick. However, the miners had to suspend the exploration of the cavity because of the extreme environmental conditions there. The temperature approached 50° C with a relative humidity close to 100%, conditions that are fatal within a few minutes. As before, the direction of the tunnel was changed and the cavity was fitted with a steel door in order to isolate it and to prevent pillaging. The cave was called “Cueva de los Cristales” and the exceptional nature of the discovery was very soon known to specialists around the world. In January 2001, it was visited for the first time by Carlos Lazcano, a veteran of Mexican speleology and a La Venta member, as well as by Claude Chabert, French speleologist of world-wide reputation, accompanied by Enrique Alejandri Escoto, head of mine security, and by the young guide Carlos Valles Carrillo. The few minutes stay allowed by the hostile environment was enough to confirm the exceptional nature of the natural phenomenon and the first images were taken of those fabulous mega-crystals, which kindled extreme interest and curiosity among experts worldwide (Fig. 1).

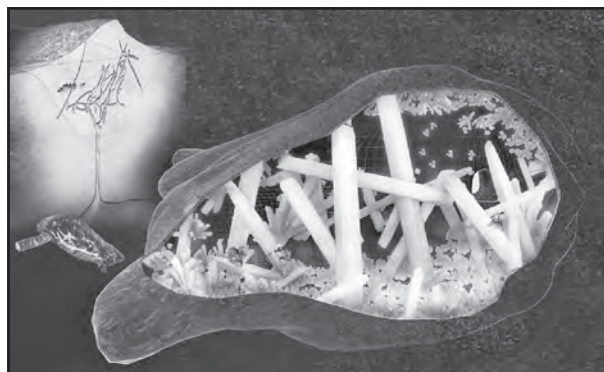

Figure 1: A 3D model of Cueva de los cristales.

3. La Venta Association in the Naica Caves

The first inspection by La Venta took place at the beginning of 2002, after an invitation by Carlos Lazcano, with a quick visit to the caves in order to become acquainted with the extraordinary nature of the phenomenon and in order to make a first quick photographic and film documentation. The following October, a second inspection took place and this time the team was better equipped to resist the extreme environmental conditions for longer than normal. The temperature at floor level turned out to be 47.1° C, while at two meters height it rose to 47.4° C, with humidity nearly at saturation.

In such an atmosphere, our bodies cannot get rid heat through evaporation; it is like dipping oneself in flowing water at that temperature, absolutely far too hot. The feeling is one of burning, because cells begin to break down at 43° C. The most important result obtained by these

investigations was to understand the operating context: Any research in those environmental conditions was practically impossible without specific technical methods and special protection. We therefore decided to develop equipment that would allow extended stays in high temperature environmental conditions, which would open the doors not only to Naica but also to other climatically similar caves. The collaboration between ourselves, the Department of General Physics of the University of Turin, the Ferrino Company, and Electrolux has allowed the development of a first prototype of conditioned suit and respiratory units. This system has been called “Tolomea” in honor of a zone in Dante’s Inferno (Canto XXXIII).

In January 2006, an agreement was signed by the Peñoles Company, holder of the mining concession, with Speleoresearch & Films, C/Producciones, and La Venta, for the exclusive right to scientific studies and photographic documentation of all the caves intersected by the mine. The “Proyecto Naica” was born. The Project is managed by the Speleoresearch & Films Society, the video and photo documentation is taken care of by the Mexican C/Producciones, and the exploration and research by the association La Venta, in cooperation with several research institutes around the world. A series of 10 expeditions (as of January 2009) have followed, which have resulted in a radical broadening of our knowledge concerning this cave. The final aim of the project is the completion of the studies, by now well underway, and then the protection of, and the dissemination of information on, this extraordinary phenomenon.

4. The Project Structure

The project is coordinated by Speleoresearch & Films, exploration and research by the Italian association La Venta, photo and video documentation by the Mexican company C/Producciones. The complexity of the project has required the definition of a scientific panel, involving several technicians and researchers from different universities. (Figs. 2, 3)

Here are the objectives and the state of the art of each sector.

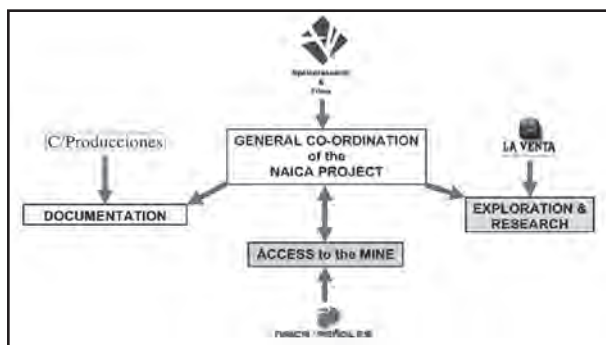

Figure 2: The institutions working on the Naica Project.

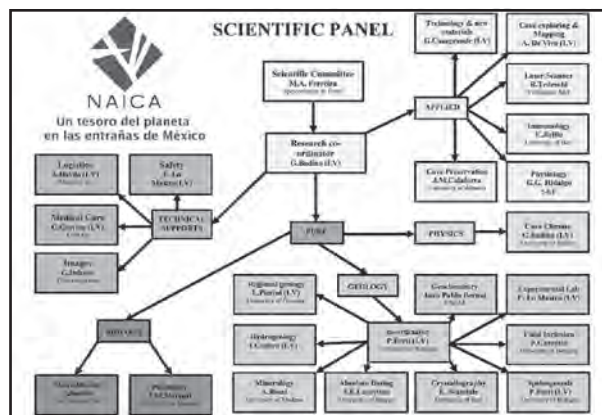

Figure 3: Naica Project structure.

4.1 Regional geology - Person in charge: Leonardo Piccini (University of Florence)

The aim of the team is to clearly describe the geologic and geomorphic conditions of the Naica area. The team has collected all the available bibliographic information, both in university libraries and on the web. The geology office of the Naica mine has given fundamental support, supplying a great amount of information. The team will complete its work by the end of 2009.

4.2 Hydrogeology – Person in charge Italo Giulivo (La Venta)

The aim is to reconstruct the evolution of the thermal aquifer, both in the past as well as after it was affected by the mining work. The team is working on elaborating aquifer models in order to evaluate its recharging time and the water permanence time inside it, which seems to be rather long according to the isotopic data.

4.3 Mineralogy - Person in charge Antonio Rossi (University of Modena)

The aim is to identify the different mineralogical phases connected to gypsum and to define the genetic processes in order to reconstruct the mineralogical evolution of the caves of Naica. The main results obtained are as follows:

A new form of gypsum was discovered, limited to Cueva de las Velas, the evolution of which is associated to the first period of artificial deepening of the water table at -290 m. These are, therefore, crystal forms that developed during few days or months around 20 years ago.

A different structure and composition was observed between the gypsum of Cueva de las Espadas and the gypsum of all the other caves at -290. This is due to the fact that the former formed at epiphreatic level,

whereas the latter in deep phreatic environment. The study of these differences, together with other data (pollens, fluid inclusions, absolute dating), will allow to reconstruct in detail the evolution of the thermal aquifer in the last thousands of years.

The mineralogical study of the solid inclusions inside the gypsum crystals and in the deposits beneath them, as well as those that started forming around twenty years ago, led to the observation of 41 minerals, 9 of which are totally new for a cave environment. The study is now concentrating on the impurities present inside the gypsum crystals of Cueva de las Espadas.

4.4 Absolute dating - Person in charge Stein Erik Lauritzen (University of Bergen, Norway)

The aim is to know the absolute age of the biggest crystals and also growth speed variations in time. So, samples from progressively deeper parts of crystals were dated by the U/Th method. The results seem to indicate an age in the range of some hundreds of thousand years. In the course of 2009, all the U/Th analyses (more than 50) will be completed.

4.5 Crystallography - Person in charge Eugenio Scandale (University of Bari)

The investigation aims at underlining the gypsum crystals characteristics in order to better understand the growth mechanism. At the present time, the team is reconstructing the growth and evolution history of the smaller crystals of Cueva de las Espadas by a characterization of the structural defects, by means of diffraction RX topography.

4.6 Speleogenesis - Person in charge Paolo Forti (University of Bologna)

The research aims at describing in detail the mechanisms that allowed the evolution of the Naica caves from the beginning to the present situation, including their chemical deposits. The study shows that, even though all the caves evolved inside the same thermal aquifer, each one presents unique features. So, each cave has been studied separately. The study shows two different speleogenetic mechanisms and four different mechanisms in the evolution of the gypsum crystals.

4.7 Fluid inclusions - Person in charge Paolo Garofalo (University of Bologna)

This study is necessary in order to define the temperature at which the crystals formed and the physical and chemical characteristics of the fluids that generated them. Together with pollen and absolute dating data, the results will allow

the paleo-environmental and paleo-climatic reconstruction of the Naica area. Several hundreds of fluid inclusions were studied, sampled from Cueva de las Espadas, Ojo de la Reina, Cueva de los Cristales, and the -590 experimental lab (see Experimental Lab). What emerges is that the fluids varied their salinity during the deposition of the crystals. Also the temperature was not constant and varied from cave to cave.

4.8 Experimental Lab - Person in charge Francesco Lo Mastro (La Venta),

At level -590, the upper level where the thermal water flows out, an experimental lab was set up in order to measure the yearly growth speed of the gypsum crystals, in environmental conditions similar to those existing before the lowering of the water table. The lab consists of an instrument designed and realized by the University of Bologna, containing 12 tablets of gypsum and 3 of limestone. The natural deposition data are checked periodically, and the test will last two to three years. The first collected tablets showed data that seem to confirm the results of the absolute dating. The final data will be available by 2010.

4.9 Geochemistry - Person in charge Juan Pablo Bernal (UNAM – Universidad Autonoma de México)

The aim of the investigation is the geochemical and isotopic characterization of the waters flowing inside the mine, in order to draw the relationship among the water themselves, the minerals, and the caves. The study started in late September 2007 with sampling of water and rocks inside the mine, with the collaboration of its Geological Office.

4.10 Microbiology - Person in charge Penelope Boston (New Mexico Tech, USA)

The research aims at verifying the presence of extremophile microorganisms trapped inside the Naica crystals and possibly study their DNA. This study is fundamental in order to understand the role of microorganisms in the evolution of the crystals and of the Naica ore deposits, in general. The first data said that the fluid inclusions do contain fossil biogenic structures, but the latter did not conserve any organic matter eventually recognizable and allowing the extraction of DNA. The next step, started in 2008, was the extraction of the liquid of some fluid inclusions: the water trapped in the fluid inclusions of Cueva de los Cristales and Cueva de las Espadas was put to culture in both aerobic and anaerobic environment. After 10 months, a biomass is developing, though very slowly. Final results are expected by mid-2010.

4.11 Palinology - Person in charge Anna Maria Mercuri (University of Modena)

The aim is to verify the presence of pollens inside the caves of Naica and their crystals. This might allow reconstruction of the paleoenvironment and the paleoclimate of the area. Samples were extracted from the bottom sediments of both Cueva de los Cristales and Cueva de las Espadas, which demonstrated the presence of small amounts of pollens. In order to verify possible contaminations, other samples collected outside were studied. The present results, based on the study of over 60 pollen grains, seem to indicate that some tens of thousand years ago the climate of the area was likely more humid and fresh. The final results will be available by mid-2010.

4.12 Cave conservation - Person in charge José Maria Calaforra Chordi (Università di Almeria, Spagna)

The aim is to find out the causes that are leading now, or could lead in the near future, to the deterioration of the environment of the Naica caves, and search for practical solutions allowing to limit or eliminate the problem. Also, to study the possibility to visit the cave after mine discontinues. This study is closely connected to the climate and physics research: the latter has demonstrated that the -290 caves are cooling down relatively fast, and the smaller one is suffering condensation processes, which lead to degeneration phenomena of the crystals. Cueva de los Cristales is not suffering condensation yet, but it is important to limit heat loss by installing airtight doors.

4.13 Climate and physics of the caves - Person in charge Giovanni Badino (University of Turin)

The climate study aims at analyzing the present conditions: temperature variations in the short and medium term; humidity variations, particularly as regards possible condensation phenomena on crystals; presence of thermal sedimentations in the cave; energy and fluid interactions with the surrounding rock; eventual existence of unknown passages and their role on the climate; the level of thermal connection with the outside; thermal history of the Naica massif, where the caves are. Systematic measurements, taken since 2006 by means of thermometric and humidity sensors, give these preliminary results:

- the cave presents a weak thermal contact with the outside, even with the doors closed
- the significant humidity variations seem to depend upon infiltration meteoric waters

- the cave contains unexplored passages with tens of meters of vertical range
- the cave is cooling at a rate of 0.5°C/year
- the cave presents thermal sedimentation processes

The monitoring will continue in the next months adding an external station and other stations at different depths inside the mine.

4.14 Physiology - Person in charge G.G. Hidalgo (Speleoresearch & Films, Mexico)

Aim of the research is to determine the safety criteria for working in this extreme environment and understand the physiological reaction of the human body, in particular as regards acclimatization. Several explorers were monitored, before, during, and after working inside the caves. This was also carried out on people specifically trained for extreme temperature and humidity conditions. The data have allowed definition of safety parameters. The team work also includes a rescue protocol in case of accident, a communication system, transportation methods, and technical rescue and medical equipment.

4.15 Laser Scanner mapping - Person in charge Roberta Tedeschi (Virtualgeo, La Venta)

The construction of a 3D digital model of the caves of Naica would give the possibility to view the relationships between the size of the caves and the development of the crystals, so allowing the researchers to carry out morphological studies without the need to physically stay inside them. Such model might also be used in public popularization, using virtual and stereoscopic images of the caves. In 2007, Virtualgeo, with the collaboration of Cam2 Faro, carried out a first test, mainly as regards the reaction of transparent crystals to the laser impulse. Five laser scans were realized in Cueva de las Espadas and Cueva de los Cristales, acquiring the coordinates and the RGB chromatic value of 47 million points.

4.16 Exploration and mapping - Person in charge Antonio De Vivo (La Venta)

The aim is to target the explorations and carry out different kinds of mapping and surveys. The lower part of the cave is completely explored, whereas some doubts persist as regards the Eastern and Northeastern areas. All the explored parts have been mapped, with a total survey polygonal of 217 m. Also, each large crystal has been mapped; the total survey sums up now to 149 crystals, approx. 90% of the total number.

4.17 Techniques and equipment - Person in charge Giuseppe Casagnande (La Venta)

The environmental conditions of Cueva de los Cristales is among the most hostile on the planet. Since the beginning, the main problem was to design techniques, equipment and methods in order to survive the necessary time for investigation. The work may be considered complete, with the final versions of the refrigerated suits and the cooling breathers. In 2008, a collaboration with NASA started in order to test some miniature instruments that in the future might be used on Mars. The first instrument was a laser excitation Raman spectrometer that worked perfectly well, showing its possibilities to carry out non-destructive

chemical analyses even in this environment.

5. Conclusions

The Naica Project has entered its fourth year, but most of the final results of the research will be available in late 2009 and 2010. The destiny of the caves of Naica is, of course, still unknown, and all the data collected in the course of the project will be fundamental once, and if, the caves are not accessible anymore. The amount of data and the multidisciplinary structure of the project indicate that the caves of Naica are probably going to be the most studied on the Planet.

ISOTOPIC STUDY OF NITRATES FROM UPPER MISSISSIPPI VALLEY SALTPETER CAVES

GREG BRICK¹, E. CALVIN ALEXANDER, JR.¹, DANIEL H. DOCTOR²

¹*Department of Geology & Geophysics, University of Minnesota, Minneapolis, MN 55455, USA*

²*Isotope Laboratory, U.S. Geological Survey, Reston, VA, 20192 USA*

There are two prominent theories for the source of nitrate in cave saltpeter: animal wastes such as bat guano, and groundwater seepage. While it has been shown that the seepage theory works well for the saltpeter caves of the southeastern US, the other model works best for guano caves in the southwestern U.S. We used a dual isotope/geochemical approach to study the origin of nitrate-rich sediments from caves, crevices, and rockshelters in Minnesota and Illinois, comparing them with samples collected from Great Saltpetre Cave in Kentucky. The dual isotope approach analyzes both the $\delta^{15}\text{N}$ and $\delta^{18}\text{O}$ in the nitrate ion. In such an analysis, nitrates deriving from animal wastes can be distinguished from those derived by nitrification of organic matter in the soil. While there is some overlap, the isotopic results suggest that some of the nitrates from Minnesota caves derive from animal waste, while other nitrate deposits, having low phosphate concentrations, likely derive from groundwater seepage.

1. Introduction

Salt peter (potassium nitrate) is one of the three ingredients of gunpowder and up through the time of the American Civil War it was often obtained by processing cave sediments. While the vast majority of saltpeter caves are found in the southeastern United States, the earliest known record of cave saltpeter in this country is from Minnesota. In 1700, the French fur-trader Pierre-Charles Le Sueur reported saltpeter caves along the west side of Lake Pepin while ascending the Mississippi River (SHAW, 1992). Le Sueur's comments about the caves being inhabited by bears in winter and rattlesnakes in summer suggests that the caves were visited with some frequency. Although not explicitly mentioned in his account, French fur-traders were interested in sources of saltpeter to manufacture gunpowder. Documentary evidence indicates that the French were making saltpeter from Missouri caves as early as 1720 (BRECKENRIDGE, 1925).

The exact location of Le Sueur's caves had been a topic of discussion since the 1981 Cave Research Foundation Symposium of saltpeter researchers, but no one actually searched for the caves before this study, to the best of our knowledge. In 2004, one of us (G.A.B.) located small, narrow, crevice caves closely matching Le Sueur's description in outcrops of the Prairie du Chien Group carbonates along the Mississippi River bluffs near Red Wing, Minnesota (BRICK, 2004). Laboratory analysis of sediments from these caves revealed nitrate concentrations more than 2% by weight. These concentrations fall within the 0.01 and 4% nitrate range reported by HILL (1981) from Mammoth Cave, Kentucky, a famous historical saltpeter mining site.

There are two prominent theories for the accumulation of cave nitrates: the traditional guano theory and the groundwater seepage theory (HILL, 1981). In the guano theory, the mineralization of nitrogenous animal wastes deposited in the caves is responsible for the nitrates, while in the seepage theory, surface soil nitrate is transported into the cave by seeping groundwater. The seepage theory best explains the saltpeter caves of the southeastern United States and the guano model works best for guano caves in the southwestern US. One goal of this project is to see if the cave nitrates in the Upper Mississippi Valley fit either theory.

We collected sediment samples from caves along the Mississippi River to help define the areal occurrence of the nitrate-rich cave sediments. The soluble major cations and anions in each sample were analyzed and the nitrate ions in selected samples were analyzed for $\delta^{15}\text{N}$ and $\delta^{18}\text{O}$. KENDALL et al (2007) have shown that such nitrate isotopic analyses can help distinguish between different nitrate sources.

2. Materials and Methods

Caves, crevices, and rockshelters along the Mississippi River were sampled in Goodhue and Wabasha Counties, Minnesota; Pierce County, Wisconsin (not further discussed in this paper); and at Mississippi Palisades State Park, Carroll County, Illinois. The last was chosen as a comparison site in a different rock formation (Niagara Series dolomite). The crevices were generally bluff-parallel joints, widened by mass movement or block rotation. Some of the voids were irregular rockshelters of solutional origin. For

comparison, sediments were also collected in Great Saltpetre Cave, Mt. Vernon, Kentucky, which had a long history of saltpeter production (ENGEL and ENGEL, 1998). Sample locations are shown in Figure 1 and listed in Table 1.



Figure 1: Location of sampling sites in Minnesota, Illinois, and Kentucky, marked as asterisks, plotted on map showing distribution of limestone caves containing saltpeter deposits (which includes Great Saltpetre Cave, Kentucky). Modified from HILL et al (1981).

Samples of floor sediments were collected with a trowel and placed in plastic bags and transported at ambient temperature to the lab. In the lab, the sediments were sieved through fiberglass window screen, weighed, and splits taken

for further processing. One split was weighed, desiccated in an oven at 80° C for three days, and reweighed, to determine moisture content. A second aliquot was placed in a measured volume of deionized water in a Nalgene bottle, shaken, and left to settle overnight. A preliminary indication of the nitrate content was made using Merck nitrate strips. Solutions showing elevated nitrate concentrations were poured through filter paper to remove debris. The alkalinity was determined by colorimetric titrations, anion concentrations by ion chromatography, and cation concentrations by cation chromatography (HAUTMAN and MUNCH, 1997). The soluble ion chemical compositions are reported relative to the dry sediment weight.

Nine samples showing elevated nitrate concentrations were analyzed at the USGS Reston Stable Isotope Laboratory for $\delta^{15}\text{N}$ and $\delta^{18}\text{O}$ values. The sediment solutions were diluted to a nitrate concentration of approximately 1 mg/L (1 ppm). The diluted solutions were frozen, packed in dry ice, and shipped to Reston, Virginia. Nitrate samples are analyzed by bacterial conversion of nitrate to nitrous oxide and subsequent measurement in a continuous flow isotope ratio mass spectrometer (SIGMAN et al, 2001; CASCIOTTI et al, 2002). Nitrogen isotope ratios are reported in parts per thousand (per mil) relative to N_2 in air (MARIOTTI, 1983). Oxygen isotope ratios are reported as per mil relative to VSMOW reference water and normalized on a scale such that SLAP reference water is -55.5 per mil (COPLEN,

TABLE 1. CAVE SEDIMENT SAMPLING LOCATIONS.

Sample	Nitrate Test Strip reading (ppm)	Cave	Lithology	Location (by County)
Minnesota				
FSP-3.5f	>500	Rockshelter, solutional origin	Prairie du Chien Group dolomite	Goodhue
PNP-E	250	Bluff-parallel crevice	Prairie du Chien Group dolomite	Goodhue
PNP-M	500	Bluff-parallel crevice	Prairie du Chien Group dolomite	Goodhue
Y-4	>500	Bluff-parallel crevice	Prairie du Chien Group dolomite	Goodhue
Y-6	>500	Rockshelter, solutional origin	Prairie du Chien Group dolomite	Goodhue
Illinois				
MPSP-3	>500	Bluff-parallel crevice	Niagaran Series dolomite	Carroll
MPSP-4	500	Rockshelter, solutional origin	Niagaran Series dolomite	Carroll
Kentucky				
GSP-3	>500	Great Saltpetre Cave, vat impression, Richard's Run	St. Genevieve Limestone	Rockcastle
GSP-12	250	Great Saltpetre Cave, regeneration pile, Main Trunk	St. Genevieve Limestone	Rockcastle

1988; COPLEN, 1994). One-sigma precision of the analyses are ± 0.25 per mil for $\delta^{15}\text{N}$, and ± 0.5 per mil for $\delta^{18}\text{O}$.

3. Results

As our sampling of the Mississippi River bluff caves expanded, approximately one-third of the sites sampled showed elevated nitrate concentrations. Surface soils in the vicinity and caves sampled elsewhere in Minnesota, by contrast, showed virtually no nitrates. The results of the chemical analyses are shown in Figure 2 and Table 2, and the isotopic results in Figure 3 and Table 3.

4. Discussion

Our preliminary isotopic results for the nine samples are displayed graphically in Figure 3. The spread between the five samples from Minnesota (FSP-3.5f, PNP-E, PNP-M, Y-4, Y-6), the two samples from Illinois (MPSP-3, MPSP-4), and the two samples from Great Saltpetre Cave (GSP-3, GSP-12) is small (8.7 per mil for $\delta^{15}\text{N}$ and 8.15 per mil for $\delta^{18}\text{O}$). All of the samples appear to have been affected by microbial processes. Within this small range, the isotopic data suggest that Minnesota samples Y-2 and Y-4 derive from guano or animal waste, and this correlates with their higher phosphate content; a plot of nitrate versus phosphate concentrations in dry soil samples is shown in Figure 2. Here, FSP-3.5f (Minnesota), MPSP-3 (Illinois), and GSP-3 (Kentucky) show elevated nitrate concentrations, yet low phosphate values, suggesting a possible groundwater seepage origin. Two of the Minnesota samples (PNP-E and PNP-M) show disproportionately elevated phosphate to nitrate, which may indicate denitrification has occurred. The other four samples fall along a trend line with nitrate proportional to phosphate suggesting a manure source.

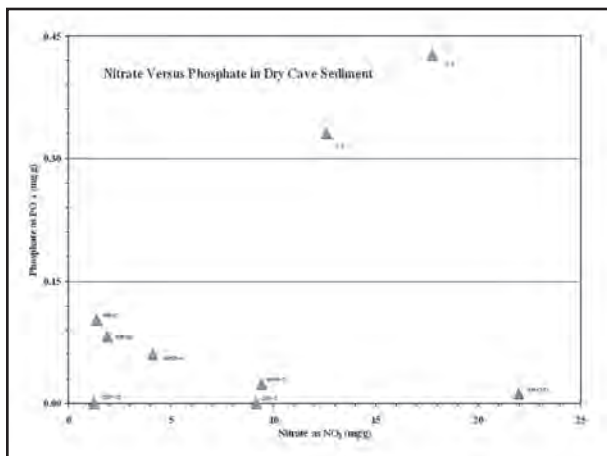

Figure 2: Plot of nitrate and phosphate concentrations in dry cave sediments.

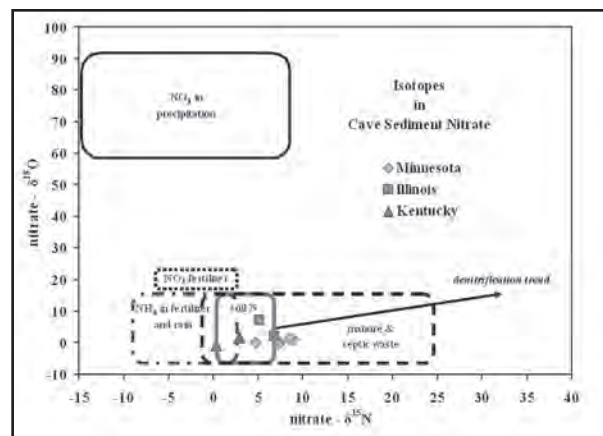

Figure 3: Plot of dual isotope analysis of nitrates in cave sediments. Enclosed areas represent known ranges of nitrate isotopic composition from various sources (modified from Kendall, 1998).

The chemical analysis shows that the soluble ions in these sediments are predominately calcium and magnesium nitrate. The magnesium/calcium molar ratio is greater than 1 for the samples FSP-3.5f, Y-4, Y-6 (Minnesota) and MPSP-4 (Illinois), which correlates with the observation that all of the rockshelters belong to this group (other samples were collected from the aphotic zones of caves or crevices). It is likely that being more exposed to convective air currents along slopes increases the rate of evaporation in these settings, leading to the evaporative precipitation of calcium carbonate. There seems to be a fairly close relationship between the concentration of nitrate and that of chloride, except for the two Illinois samples (MPSP-3 and MPSP-4), which may indicate an independent chloride source for these two.

5. Conclusions

Stable isotope studies involving natural abundances of the dual isotopes $\delta^{15}\text{N}$ and $\delta^{18}\text{O}$ in the nitrate ion, coupled with analyses of the soluble cations and anions, have the potential to help discriminate between nitrate deposits in cave sediments formed primarily through the mineralization of animal waste, from those formed by the groundwater seepage mechanism. Further sampling and analysis will be required to extend these preliminary results.

Acknowledgements

The authors gratefully acknowledge a National Speleological Foundation grant to support Greg Brick's research on cave nitrates; the Department of Geology & Geophysics, University of Minnesota, for a summer travel grant; the Rockcastle Karst Conservancy for permission to sample Great Saltpetre Cave during the 2008 Karst-O-Rama; Dr. Daniel Doctor (USGS) for assistance with analysis and

TABLE 2. CHEMICAL ANALYSIS REPORTED AS MILLIGRAMS PER GRAM OF DRY CAVE SEDIMENTS.

Sample	Alk as CaCO ₃ (mg/L)	NO ₃	Soil NO ₃ %	Cl	PO ₄	SO ₄	Ca	Mg	Na	K	Sr
Minnesota											
FSP-3.5f	47.3	21.98	2.20	0.810	0.013	8.239	4.142	3.067	0.228	1.209	0.004
PNP-E	142.7	1.36	0.14	0.026	0.103	0.138	0.654	0.182	0.022	0.151	0.001
PNP-M	114	1.89	0.19	0.031	0.083	0.314	0.700	0.211	0.027	0.116	0.001
Y-4	65.7	17.75	1.77	0.217	0.427	2.960	4.916	1.426	0.092	1.437	0.004
Y-6	78.8	12.57	1.26	0.279	0.331	7.083	2.457	2.073	0.240	1.283	0.002
Illinois											
MPSP-3	54.3	9.42	0.94	0.898	0.025	27.545	4.914	5.337	0.349	0.516	0.012
MPSP-4	50.5	4.11	0.41	0.777	0.061	4.757	1.075	1.242	0.330	0.216	0.003
Kentucky											
GSP-3	22.6	9.15	0.91	0.234	0.001	1.022	1.989	0.166	1.010	0.086	0.013
GSP-12	22.9	1.24	0.12	0.015	0.001	0.070	0.339	0.035	0.038	0.026	0.002

TABLE 3. Results of dual isotope analysis of nitrates from cave sediments.

Sample	NO ₃ as N (ppm)	Reston LabID	δ ¹⁵ N (AIR)	δ ¹⁸ O (VSMOW)	State
FSP-3.5f	1.003	G-12610	4.66	0.00	MN
PNP-E	0.997	G-12611	7.41	0.12	MN
PNP-M	1.003	G-12612	7.23	-0.32	MN
Y-4	0.987	G-12617	8.90	1.06	MN
Y-6	0.986	G-12618	8.46	1.46	MN
MPSP-3	0.996	G-12619	6.77	2.16	IL
MPSP-4	0.998	G-12624	5.08	7.19	IL
GSP-3	1.003	G-12625	2.88	1.59	KY
GSP-12	0.995	G-12634	0.25	-0.86	KY

interpretation of the isotopic data; and Scott C. Alexander for preparation of graphical data.

References

- BRECKENRIDGE, W.C. (1925) Early gunpowder making in Missouri. *Missouri Historical Review* **20**, 85–95.
- BRICK, G. (2004) Preliminary notice of the rediscovery of Le Sueur's saltpeter caves in Minnesota. *Journal of Spelean History* **38**, 56.
- CASCIOTTI, K.L., D.M. SIGMAN, M.G. HASTINGS, J.K. BÖHLKE, and A. HILKERT (2002) Measurement of the oxygen isotopic composition of nitrate in seawater and freshwater using the denitrifier method. *Analytical Chemistry* **74**, 4905–4912.
- COPLEN, T.B. (1988) Normalization of oxygen and hydrogen isotope data. *Chemical Geology (Isotope Geoscience Section)* **72**, 293–297.
- COPLEN, T.B. (1994) Reporting of stable hydrogen, carbon, and oxygen isotopic abundances. *Pure and Applied Chemistry* **66**, 273–276.
- ENGEL, S.A., and A.S. ENGEL (1998) Great Saltpetre Cave, Rockcastle County, Kentucky: A geology and

- archeology field guide. *Electric Caver*, March issue. (Available on-line at <http://www.rcki.org>.)
- HAUTMAN, D.P. and D.J. MUNCH (1997) Method 300.1 Determination of inorganic anion in drinking water by ion chromatography. U.S. Environmental Protection Agency, Cincinnati, OH, 39 p. In: *EPA—Methods for Chemical Analysis of Water and Wastes*, EPA-600/4-79.020.
- HILL, C.A. (1981) Origin of cave saltpeter. *National Speleological Society Bulletin* **43**, 110–126.
- HILL, C.A., D. DePAEPE, P.G. ELLER, P.M. HAUER, J. POWERS, and M.O. SMITH (1981) Saltpeter caves of the United States. *National Speleological Society Bulletin* **43**, 84–87.
- KENDALL, C. (1998) Tracing nitrogen sources and cycles in catchments. Chap. 16 in *Isotope Tracers in Catchment Hydrology*, C. Kendall and J.J. McDonnell (Eds). Elsevier, Amsterdam, pp 519–576.
- KENDALL, C., E.M. ELLIOTT, and S.D. WANKEL (2007) Tracing anthropogenic inputs of nitrogen to ecosystems. Chap. 12 in *Stable Isotopes in Ecology and Environmental Science*, 2nd ed., R.H. Michener and K. Lajtha (Eds.) Blackwell Publishing, Malden, MA, USA, pp 375–499.
- MARIOTTI, A. (1983) Atmospheric nitrogen is a reliable standard for natural ^{15}N abundance measurements. *Nature* **303**, 685–687.
- SHAW, T.R. (1992) *History of Cave Science: The Exploration and Study of Limestone Caves, to 1900*, 2nd ed. Sydney Speleological Society, New South Wales, Australia, 338 pp.
- SIGMAN, D.M., K.L. CASCIOTTI, M. ANDREANI, C. BARFORD, M. GALANTER, and J.K. BÖHLKE (2001) A bacterial method for the nitrogen isotopic analysis of nitrate in seawater and freshwater. *Analytical Chemistry* **73**, pp 4145–4153.

MEASUREMENT OF RELATIVE HUMIDITY IN CAVES

ROBERT H. BUECHER

Buecher Biological Consulting, 7050 E. Katchina Court, Tucson, AZ 85715

Abstract

Relative humidity (RH) is a sensitive indicator of the balance between moisture supply, temperature, and airflow in caves. Relative humidity and evaporation from cave surfaces is an important aspect of cave microclimate and a controlling factor in determining the morphology of speleothems and suitability for cave dependent organisms. To understand these processes, one must be able to accurately measure relative humidity at near saturation conditions typically found in many caves. Typical methods using sling psychrometers and solid state devices provide inadequate accuracy above 95% relative humidity because of their lack of sensitivity at high humidity. Therefore, specialized methods and techniques are required to make meaningful measurements > 95% RH. A review of several methods for measuring evaporation is presented including: evaporation pans, Piche evaporimeters, wet bulb/dry bulb thermometers, solid state sensors and use of a soil psychrometer, perhaps the most useful instrument of all. Results using these specialized techniques from two U.S. caves - Kartchner Caverns, Arizona and Lechuguilla Cave, New Mexico are presented. Because it is critical to maintain relative humidity for the preservation of speleothems and the survival of cave-adapted organisms, accurate measurement of relative humidity should be included in all cave inventories.

CAVE MINERAL DATABASE: A JOINT COLLABORATION BETWEEN GEOLOGISTS, LIBRARIANS, AND PROGRAMMERS

BEVERLY CAGGLIANO¹, BOGDAN P. ONAC^{2,3}, TODD CHAVEZ¹

¹University of South Florida Libraries, 4202 E. Fowler Ave., LIB 122, Tampa, FL 33620, USA

²Department of Geology, University of South Florida, 4202 E. Fowler Ave., SCA 528, Tampa, FL 33620, USA

³"Babeş-Bolyai" University Cluj/"Emil Racoviţă" Institute of Speleology, Clinicilor 5, 400006 Cluj, Romania

Abstract

The Cave Mineral Database (CAMIDA) is a collaborative project of the University of South Florida Libraries, UIS's Cave Minerals Commission, the Karst Information Portal, "Emil Racoviţă Institute of Speleology (Romania), and the Karst Research Group at University of South Florida (USA). CAMIDA is an open-access collection of geological, mineralogical, crystallographical, and protection/conservation information on all minerals discovered in caves (including lava tubes) around the world. It holds and organizes large amounts of information (including polarizing, scanning, and transmission microscope photos), and makes any item immediately accessible. It also provides links to many other integrated database of Raman spectra, X-ray diffraction and chemistry data for minerals. CAMIDA was created under CollectiveAccess management application using PHP scripting language.

CollectiveAccess (formerly the OpenCollection project) is an open-source collection management application that allows users to catalog, publish, and disseminate diverse collections and data. This diversity is illustrated by the variety of successful projects based on the application including the Berkeley Natural History Museum's anthropological artifact collection database (over 600,000 objects), the media collections of the Center for Biodiversity Conservation (American Museum of Natural History), and the Frick Collection and Frick Art Reference Library.

CollectiveAccess is designed to manage large, complex collections with dynamic cataloging requirements that require varying metadata standards to describe diverse digital content formats. The public interface and all management tools are completely web-based and thus cross operating system boundaries and facilitate distributed contribution of content and associated metadata. The application utilizes PHP programming (version 5.2.3 or higher) and runs on Apache web server configurations. The application's public interface can be exhaustively modified to meet specific user-experience requirements. CollectiveAccess supports authority tools to manage content attributes, controlled vocabularies defined by the targeted research community, and georeferencing using KML/KMZ file exports from such resources as Google Earth.

There are at least three reasons for creating such a Web-based mineralogical database: (1) the data (various information and images) can easily be archived, (2) to keep the database updated takes a shorter time and less money than printing new book editions, and (3) being an open-access database, more cavers and scientists can add and use the data therein.

HALITE MACROCRYSTALLINE STALACTITES OF THE ATACAMA CAVES (CHILE)

JO DE WAELE¹, PAOLO FORTI¹, VINCENZO PICOTTI¹, LUCA ZINI²

¹*Dipartimento di Scienze della Terra, Università di Bologna, via Zamboni 67, Bologna, 40125 Italy*

²*Dipartimento di Scienze della Terra, Università di Trieste, Via E. Weiss, 34127 Trieste, Italy*

Interesting salt caves were recently discovered in one of the driest places on earth, the Atacama desert (Chile). The caves, sometimes over 1 km long, host important and widespread active halite speleothems among which are peculiar macrocrystalline stalactites, described here for the first time. The macrocrystalline stalactites consist of a sequence of interpenetrated halite cubes, often with a hopper structure. The halite cubes are always oriented with the long diagonals coincident with the speleothem elongation axis. A few of these stalactites exhibit a perfectly vertical structure, while most of these speleothems are inclined (with a deviation from the verticality up to 40-50 degrees). Internal feeding tubes are completely absent. The evolution of these speleothems is induced only by condensation/evaporation processes. While the feeding of these speleothems is always related to condensation processes, their evolution is controlled by several interconnected factors: 1 - air current distribution close to the speleothems, 2 - condensation and evaporation processes, and 3 - capillary, and/or gravitational movements of the solution along the speleothems. In many cases these factors allow for the development of strange hopper structures, giving rise to wide rectangular thin flat tabular crystals. Finally in a single location, peculiar bidimensional pyramidal structures of halite crystals have developed where the gravitational flow of the feeding solutions meets a strong upward air flow.

1. Introduction

Halite speleothems have been described from several caves worldwide. While most of these exist in salt caves, they also may develop in other natural cavities within different rocks (HILL and FORTI, 1997). Interesting salt caves (PADOVAN, 2003; FRYER, 2005; SESIANO, 2006; BRESSAN, 2008) were recently discovered and explored in one of the driest places on earth, the Atacama desert (Chile), where the mean annual rainfall is below 20 mm /yr and often null during several subsequent years. The caves, sometimes over 1 km long, are developed inside a huge halite formation, the "Cordillera de la Sal", located a few kilometers southwest of the village of San Pedro de Atacama (DE WAELE et al., 2009a). They host important and widespread active halite speleothems (DE WAELE et al., 2009b) - from huge columns and flowstones to delicate helictites and cotton-balls. The Atacama climate does not allow any water seepage inside the halite outcrop for very long periods, thus the speleothems developed by dripping and/or flowing waters are scarce inside all the caves and they seem to be inactive. Their evolution probably occurred some hundred years ago in a slightly wetter climate and then stopped (DE WAELE et al., 2009a, b). This hypothesis is strengthened by clear evidence that water seepage during the

rare rainstorms normally causes the complete demolition of the speleothems by fast dissolution and/or by induced breakdowns. All the presently active halite deposits in the Atacama caves are fed by condensation water and their development is controlled mainly by evaporation and, to a much lesser extent, by dripping. The Zorro Andina cave is the only one in which peculiar speleothems, consisting of macrocrystalline halite, have been observed (FRYER, 2005). These macrocrystalline stalactites consist of a sequence of interpenetrated halite cubes, sometimes with a hopper structure. The halite cubes are always oriented with the long diagonal coincident with the speleothem elongation axis, thus forming a single crystal structure (parallel growth). A few of these stalactites exhibit a perfectly vertical development, while most of these speleothems are inclined (with a deviation from the verticality up to 40-50 degrees). Internal feeding tubes are always absent. Within the stalactites some of the halite crystals have a perfect euhedral structure but most of them exhibit more or less developed hopper structures. In a few cases the hopper structures become so developed to give rise to wide thin tabular crystals, bordering the external surface of the speleothems. A few of the inclined stalactites exhibit smaller vertical overgrowths from the lower vertex of some of the

halite crystals and finally, in a single location - where strong condensation occurs in a small shelter partially protected from the fast air flow existing in the main cave passage - peculiar bi-dimensional pyramidal structures of halite crystals have developed. None of these peculiar speleothems have so far been described and therefore the parameters ruling their genesis and evolution are here discussed in detail.

2. The Genesis and Evolution of the Monocrystalline Speleothems

Zorro Andina Cave differs from the other actually known cavities of Atacama because it practically lacks roofless passages, and therefore in its inner part a higher relative humidity is preserved. Along the whole cave there are plenty of relatively huge halite speleothems (flowstones, columns, stalactites...), but most of them, at the time of our visit, were completely inactive and some details (like the perfectly preserved old chisel marks made by halite miners over some of them) suggest that they stopped their development long ago. The situation is rather different in the inner part of the cave, where most of the speleothems are clearly active and some of the stalactites evidence dripping from their tips.

All the macrocrystalline stalactites are restricted to this section of the cave. It is evident that their development is strictly related to the peculiar microclimate characterizing this portion of the cave. In this area the cave passages consist of a series of short bended meanders in which a relatively high air flow is always present due to the existence of cave entrances at different levels and exposures. The almost adiabatic compression and consequent expansion of the air flow along the meanders induces condensation processes during long periods if not all the year round, which clearly are responsible for the genesis and the evolution of the macrocrystalline stalactites. The complete lack of an internal feeding tube confirms that seeping water plays no role in their development. While the feeding of these speleothems is always related to condensation processes, their evolution is controlled by several interconnected factors:

1. supersaturation
2. air current distribution close to the speleothems
3. capillary, and/or gravitational movements
4. condensation/evaporation rates

2.1 Supersaturation

The presence of a monocrystalline structure is clear evidence that the supersaturation of the feeding solution is maintained at a reasonably low degree, thus promoting the (bi-dimensional) process of the enlargement of the

already existing crystals instead of the (tri-dimensional) nucleation of new crystals. Anyway supersaturation must be high enough to allow the competitive growth of the crystals parallel to the direction of speleothem elongation (MOORE, 1962). It has already been proved that competitive growth applies also to isometric crystals such as halite cubes (FORTI and BUZIO, 1985). Therefore, the crystal orientation observed in the stalactites of Zorro Andina cave is the expected one and it is also an indirect proof that the supersaturation degree of the feeding solution is maintained constant during the whole speleothem development. This, in turn, is strong evidence that all the feeding water comes from condensation processes and the seepage of meteoric water induced by the rare rainfalls has no possibility to mix with the condensation one.

2.2 Air current distribution close to the speleothem

Lacking the internal feeding tube, all the water flows on the external surface of the stalactites driven by capillarity and gravity. In general, gravity flow is by far a subordinated phenomenon with respect to capillarity due to the scarcity of the volume of water involved. In any case dripping sometimes occurs and more frequently small drops permanently hang from the lower crystal vertexes. Normally the overall movement of the solution is vertical, because the prevalence of capillary over the gravitational flow will produce no horizontal displacement, and therefore a symmetric straight stalactite will develop (Fig. 1). The same result is also obtained if an air current regularly inverts its direction at the site of the speleothem. The time of application of this perturbation is short and therefore will be immediately balanced by the flow inversion. The presence of inverting air flow may just be the cause of the development of the hopper structures which characterize most of the halite crystals by enhancing the evaporation along the edges of the crystal faces. Inside Zorro Andina Cave the macrocrystalline vertical stalactites are rare when compared to those inclined towards the centre of the gallery. This is due to the fact that, normally, the air flow progressively increases from the walls toward the centre of the gallery and consequently the evaporation increases in the same direction. Therefore each halite stalactite must organize its crystals with the long diagonal oriented exactly toward the direction of maximum evaporation.

2.3 Capillary and/or gravitational movements

The presence close to each other of some macrocrystalline stalactites with different inclinations seems to contradict this rule, but they may easily be explained by a competition between capillarity and gravity flows (Fig. 2). In fact, gravity

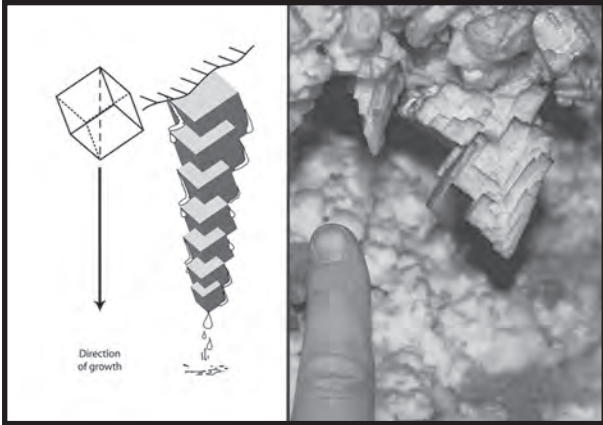

Figure 1: Evolution of a vertical halite macrocrystalline stalactite: due to the competitive growth the interpenetrated cubes have their long diagonal coincident to the stalactite axis which is parallel to the vertical. Verticality is also maintained if the water supply is only by capillarity in absence of an air flow gradient with a horizontal component.

will always induce a vertical flow while capillary causes a movement of the water exactly toward the places where the evaporation is highest. If no dripping occurs, the net

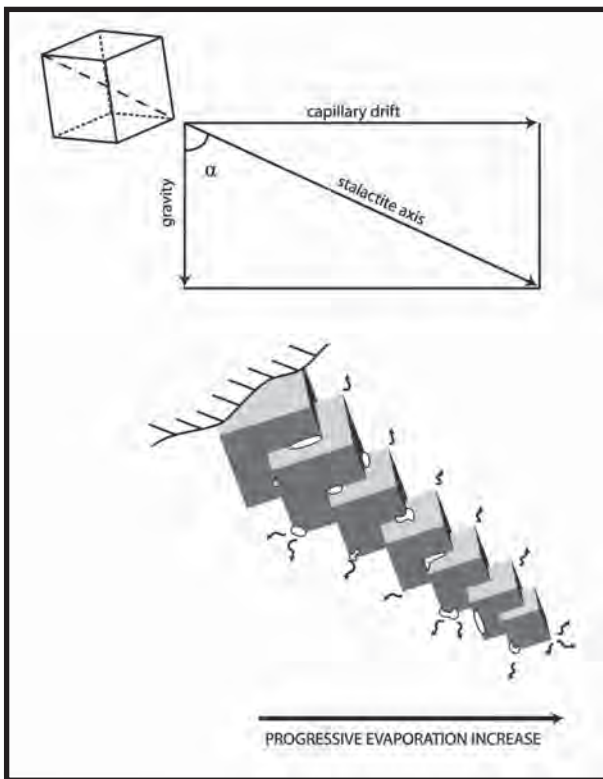

Figure 2: In the presence of an air-flow gradient with a horizontal component and no active dripping, the growing axis of the macrocrystalline stalactite has a direction that corresponds to the vectorial sum of gravitational and capillary flows (top).

direction of stalactite axis, corresponding to the direction of growth, is obtained by the vectorial combination of the two different flows (Fig. 2 top). If the gravity flow exceeds the evaporation rate, dripping must start from one, or more, lower crystal vertexes of the inclined stalactite. If this occurs, small secondary stalactites immediately start to develop from the crystal tips, and these new speleothems will grow with their long diagonal parallel to vertical due to the fact that in this case dripping is the controlling factor (Fig. 3)

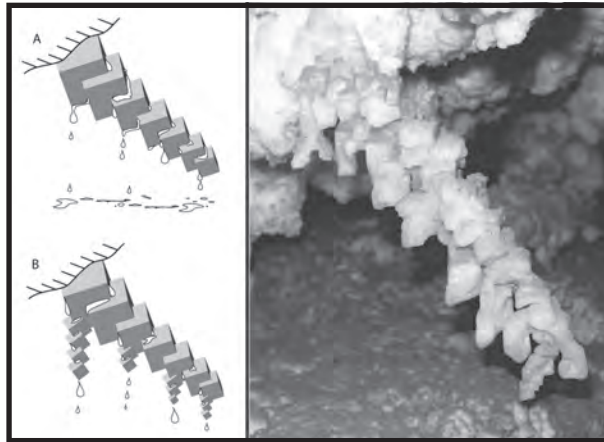

Figure 3: In the presence of an air flow gradient with an horizontal component and an active dripping, new vertical stalactites develop from the lower tips of the crystals by dripping.

2.4 Condensation/evaporation rates

The balance between water supply (i.e. condensation rate) and evaporation is crucial for the development of the macrocrystalline speleothems of Zorro Andina Cave, and this parameter seems to be the ruling factor controlling the establishment of the competitive selection among developing crystals. If the evaporation exceeds condensation, then supersaturation at the evaporation points may rapidly become very high and therefore will allow fast and easy nucleation, thus stopping the selective competition among the halite crystals. This will cause an overgrowth consisting of small to very small microcrystalline grains in which the single halite crystals presents random orientations instead of a single one. This overgrowth will rapidly mask the original macrocrystalline structure. If fast evaporation is restricted to selected places (like crystal faces perpendicular to strong air currents) the water supply may be enough to maintain active selective competition: in this case exasperated hopper structures develop giving rise to the large thin tabular crystals described before. The development of these flat structures may interfere with the air flow, which will be somehow diverted thus giving rise to similar structures just at the opposite side of the stalactite (which will be

normally untouched by the air current). On the other side, if condensation rate over the ceiling is too high, the water flowing over the speleothems may have insufficient time to become saturated and therefore it becomes aggressive with respect to the macrocrystalline stalactites which start to dissolve. A borderline case may also occur: the rate between water supply and evaporation is just enough to induce an extremely scarce supersaturation which is unable to maintain actively the selective competition but which still allows some halite deposition on the top of a monocrystalline stalactite via epitaxy. This kind of deposition is effectively active only in a very small area of Zorro Andina Cave, consisting of a small rounded cavity at the top of the wall in the inner part of a short meander bend, where a very fast condensation occurs. Here, needle-like short monocrystalline speleothems develop until their tips reach the open space where suddenly they meet a strong upward air flow (Fig. 4). These conditions are just those needed for the development of trays - speleothems that enlarge progressively their thickness toward the direction of increase of evaporation and present a flat wide lower surface (HILL & FORTI 1997). The peculiarity of trays in Zorro Andina Cave is that they have a monocrystalline structure due to the very low supersaturation degree of the feeding solutions. Their progressive enlargement occurs only in two dimensions because the strong air current responsible for the trays' evolution occurs in a rather thin layer due to the geometry of the cave wall.

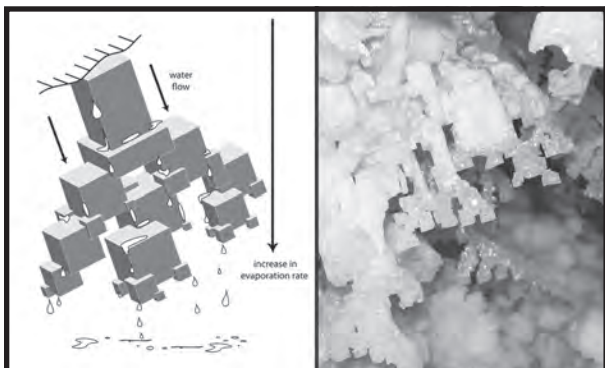

Figure 4: Bi-dimensional pyramid-like monocrystalline trays develops where the dripping is fast and the evaporation rate suddenly increases due to a "sheet" air flow.

3. Final Remarks

Presently the Atacama climate is surely unsuitable for the development of speleothems. In fact, most of the big formations observed inside the halite caves in the Cordillera de la Sal have been inactive for a long time. Anyway, they

still host developing speleothems, the growth of which is strictly related to condensation/evaporation processes. Peculiar macrocrystalline stalactites have been observed in only one location. Their genesis and evolution is discussed here for the first time, where it is proved that they formed by different factors, the most important of which are: (1) supersaturation degree of the feeding solution, (2) capillary and/or gravity flow along the speleothem, and (3) air currents.

References

- BRESSAN G. (2008) Speleologia nella Cordillera de la Sal, Cile. *Speleologia Veneta* 16, 91–108
- DE WAELE J., V. PICOTTI, P. FORTI, G. BROOK, F. CUCCHI, and L. ZINI (2009A) Age of caves in the Cordillera de la Sal (Atacama, Chile) *Proceedings 15th International Congress of Speleology*, Kerrville
- DE WAELE J., V. PICOTTI, L. ZINI, F. CUCCHI, P. FORTI, E. GALLI, A. ROSSI (2009B) Karst phenomena in the Cordillera de la Sal (Atacama, Chile) *Geoacta*, Bologna, in press
- FORTI P. and E. BUZIO (1985) Le concrezioni e le mineralizzazioni delle grotte di Monte Sedom. In *Monte Sedom* Gruppo Grotte Milano CAI (Ed), Milano, Italy, 23–39
- FRYER, S. 2005 Halite caves of the Atacama desert *National Speleological Society News* 63(11), 4–19
- HILL, C.A., and P. FORTI, (1997) *Cave Minerals of the world*. National Speleological Society, Huntsville, 464 pp.
- MOORE G.V. (1962) The growth of stalactites. *National Speleological Society Bulletin* 24(2), 95–106.
- PADOVAN E. (2003) Il sistema carsico della Cordillera de la Sal nel deserto di Atacama. *Progressione* 48, 37–49.
- SESIANO J. (2006) Evolution actuelle des phénomènes karstiques dans la cordillera de la Sal (Atacama, Nord Chili). *Karstologia* 47, 49–54

MINEROGENESIS IN THE NAICA CAVES (CHIHUAHUA, MÉXICO)

PAOLO FORTI¹, ERMANNO GALLI², and ANTONIO ROSSI²

¹-Naica Project, La Venta Exploring Team & Italian Institute of Speleology, via Zamboni 67 Bologna, 40125 Italy

²-Dipartimento di Scienze della Terra, Università di Modena e Reggio Emilia, Italy

At the beginning of the 20th Century the Naica mine became world renown when the largest gypsum crystals of the whole planet were found inside. Since 2000 four new caves were discovered deeper inside the same mine, hosting gigantic gypsum crystals (over 12 m long). In 2005 an International project led by Speleoresearch & Film of Mexico City and La Venta Exploring Team from Italy started to study all the scientific aspects related to the development of these crystals. In the framework of this project, a detailed analyses has been performed on the secondary minerals hosted inside the Naica caves. This research reveals a completely unexpected mineralogical richness for an environment apparently completely filled by gypsum: 40 minerals have been observed, 10 of which are new for the cavern environment. These minerals developed in three different environments (deep phreatic, epiphreatic and aerated). The aerated environment, even though active only in a short interval of time (a few hundred years) in respect to the other two which lasted many hundreds of thousands of years, allows the highest mineralogical variability in the still now-forming compounds (35, among which 25 are exclusive of this environment).

1. Introduction

The systematic study of “mine caves” has emphasized the high scientific interest of the minerogenetic processes active therein and consequently of the crystals that they sometimes host. From this point of view, the natural cavities crossed by mine galleries in Naica (Chihuahua, México) (Fig. 1) have been world renowned for over a century, due to the dimension and purity of their gypsum crystals (HILL & FORTI, 1997). Besides Cueva de las Espadas (Cave of the Swords), unveiled at the beginning of the 20th century at the -120 level, where crystals up to 2 meters in length exist (DEGOUTIN, 1912, FOSHAG, 1927), in the last 6–7 years mine galleries at the -290 level have intercepted several natural cavities, the most important of which are Cueva de los Cristales (Crystal Cave), Ojo de la Reina (Queens Cave), Cueva de las Velas (Sails Cave) and Cueva de Tiburon (Shark Cave). All these caves host gypsum crystals much bigger than those in the Cave of the Swords. The largest of these crystals, some 12 m in length and 1.7 in width, have been found in Crystal Cave. Even if these crystals are by far the largest gypsum crystals in the world, the scientific importance of the caves is not confined to this aspect. The Naica Project is a general research project which the owner of the mine, the Peñoles Company, committed to La Venta Exploring Team and Speleoresearch & Films in 2006 to study and document these cavities. In the framework of this project, a detailed analyses has been performed on the secondary minerals developed inside the Naica caves.

2. The Chemical Deposits

The main characteristic of all the Naica caves is the presence of thick chemical deposits (Fig. 2), the large majority of which

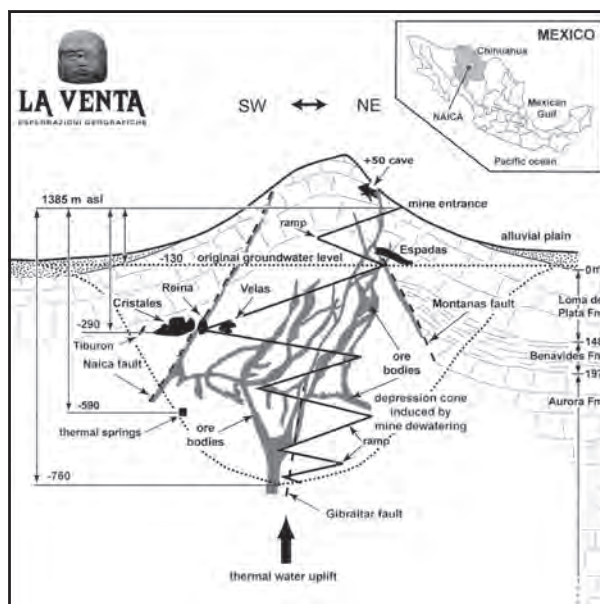

Figure 1: Sketch of the Naica mine in which the largest natural cavities, closely connected to the main faults, are related to the original groundwater level. On the right the stratigraphic sequence is derived from several drilled cores within the Naica Ridge (after FORTI 2009, modified).

consists of giant gypsum crystals. The only place in which gypsum deposition never occurred is the +50 cave, located at the highest level within the Naica ridge. This cavity is also the single one in which gravitational calcite speleothems developed, the presence of which testifies that this cavity was water-free since long time, probably long before the gypsum deposition started. Besides gypsum some other minerals were deposited before and/or during the development of the

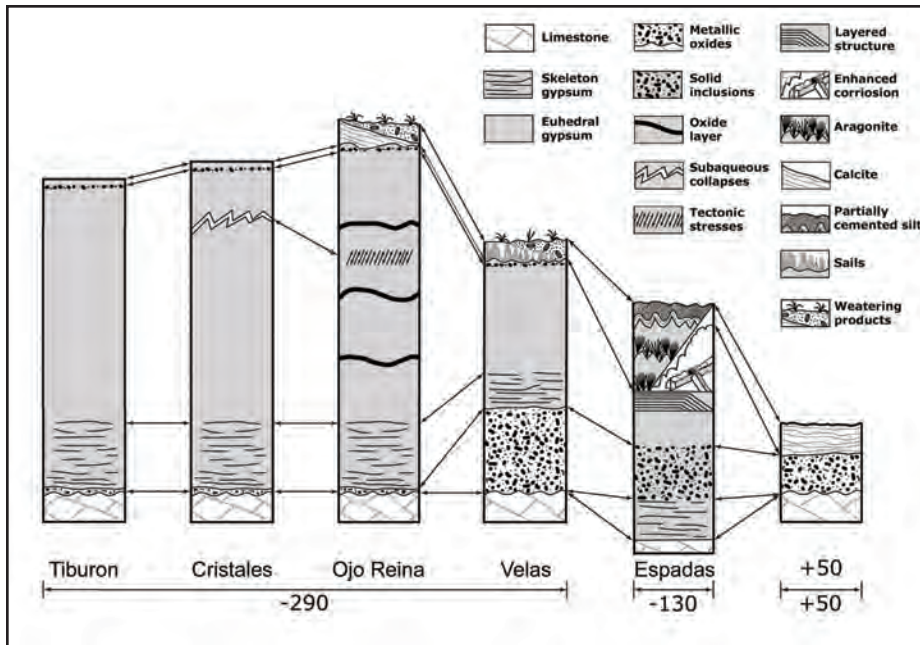

Figure 2: Stratigraphic sketch of the chemical deposits present in each of the Naica caves and their relationships: the deposition sequences are different from cave to cave but many of the in-volved processes are the same, and it was possible to correlate most of them (see arrows) (after FORTI 2009, modified).

gypsum crystals and many more are actually forming now (FORTI, 2009; FORTI et al. 2007, 2008, 2009), the genesis of which is strictly related to the recently established aerate conditions.

2.1 Minerals developed in deep phreatic environment

All five caves with gypsum inside show a depositional sequence which slightly differs from cave to cave. In the four caves located at -290 the deposition of the metallic oxides-hydroxides occurred before the beginning of the gypsum deposition, while in the Cueva de las Espadas this process started when the gypsum crystals were already forming thus causing the development of a thick interval of solid inclusions inside these crystals. In all the caves gypsum deposition was induced by the gypsum-anhydrite solubility disequilibrium (GARCÍA RUIZ et al., 2007). This method of development of the gypsum crystals was indirectly confirmed by the presence just below or even inside the gypsum of small celestite crystals; in fact, it has been demonstrated that anhydrite structure may host more strontium than gypsum (BUTLER 1973). The mechanism of gypsum deposition which becomes active only below 59° C also explains why in the Cueva de las Espadas the gypsum deposition started earlier than in the caves of the -290 level. In fact the location of this cavity is some 160 m higher and it was also very close to the top of the thermal aquifer, where the temperature lowering was obviously faster. The development of few huge crystals instead of many small ones is justified by

the fact that the temperature drop was extremely slow. The giant crystals developed in a temperature range between 55–58° C (GAROFALO et al. 2008) over a time interval of some hundred thousand years according to the first $^{230}\text{Th}/^{234}\text{U}$ dates (LAURITZEN et al., 2007). The latest stage in the development of the gypsum crystals was different in the caves of -290 level with respect to the Cueva de las Espadas due to the progressive lowering of the groundwater level.

In the Cristales, Reina, Velas and Tiburon caves the gypsum deposition continued unperturbed until 20 years ago, when the mine

dewatering stopped the process. A common characteristic of all the gypsum crystals of these caves is the presence of a very thin solid inclusion layer about 1 mm below the crystals surfaces. The thickness and density of such a layer is not uniform but it is more evident and thick in the crystal faces exposed upward, thus suggesting a gravitational deposition of these impurities after the beginning of the mining activities some 120 yr BP. Mine dewatering did not correspond to the stop in the gypsum deposition at least inside the Cueva de la Velas, where a completely new form of gypsum crystal was developed just in the few tens of days of its dewatering. These gypsum crystals (called “the sails”) have a genesis which was controlled by the capillary uplift along the crystal faces and strong evaporation from the crystal vertexes pointing upward (BERNABEI et al., 2007). In the Cueva de las Espadas the latest stage in the evolution of gypsum was characterized by several well-visible growing layers, within the final 5–6 mm of the crystal development. These layers may be referred to as an oscillation of the thermal/fresh water boundary just at the level of this cave (PANIERI et al., 2008). Later, two episodes of partial emersion of the Cueva de las Espadas were recorded inside several pseudo-stalagmites on the bottom of the terminal lake before the final total emersion of the cavity. The analyses (FORTI, 2007) of a polished section of these speleothems revealed the presence of an inner nucleus consisting of a prismatic gypsum euhedral crystal over which developed two white layers of acicular aragonite alternating with two layers of gypsum macrocrystals. Then the speleothem was covered

with a thin layer (1–2 mm) of hazel-brown calcite and finally by poorly cemented clay-silty deposits, which represent the latest stage in the depositional sequence of this cave. During the low stand of the groundwater, the ingress of air in the upper part of the cave is responsible for the development of aragonite due to the diffusion of CO₂ into the thermal water. The subsequent highstand levels of groundwater re-established saturated conditions and therefore gypsum was deposited. The film of brown calcite corresponds to the definitive lowering of the thermal aquifer below the level of Cueva de las Espadas, which was started by a moderate flow of fresh water which induced the deposition of calcite instead of aragonite. This period was drastically interrupted by mining activities, which changed dramatically the hydrogeology of the whole area and also intercepted fresh water seepage feeding the cave, thus causing the deposition of the silt and clay deposits, which are the latest deposits in this cave. By using the thickness of all these different layers, it seems that the whole sequence of observed events (from layering of the gypsum crystals to silt deposition) took only a few thousand years. When the gypsum deposition already started in the uppermost part of the aquifer (Cueva de las Espadas), but where in the -290 caves the temperature was still too high, Naica ore bodies underwent a strong oxidation phase which caused the development of several minerals (mainly oxides-hydroxides, but also sulphates and silicates). This process was controlled by specific microorganisms, as testified by biogenic structures frequently fossilized within these deposits. Most of these deposits are amorphous, and only two oxides-hydroxides have been detected: coronadite [(Pb(Mn⁴⁺, Mn²⁺)₈O₁₆)] and göthite [α -Fe³⁺O(OH)]. These minerals are the direct product of the phreatic oxidation of the polysulphides ore bodies, sources for all the needed metallic ions. Few crystals of some other minerals are dispersed inside them: calcite (CaCO₃), dolomite [CaMg(CO₃)₂], celestine (SrSO₄), fluorite (CaF₂), opal (SiO_{2,n}H₂O), quartz (SiO₂), and hectorite [Na_{0.03}(Mg,Li)₃Si₄O₁₀(F,OH)₂]. This magnesium phyllosilicate was observed for the first time in a cave. Its genesis is related to the pH decrease as a consequence of the ore bodies oxidation, which reduced the silica solubility enhancing also the opal and quartz deposition and the increase of magnesium concentration in the feeding waters (GAROFALO et al., 2008).

2.2 Minerals developed in epiphreatic conditions

Five carbonates have been found in the caves of Naica: aragonite, azurrite, calcite, dolomite and malachite. Most of these minerals developed in epi-phreatic and/or aerated conditions, and therefore in a period in which the development of giant gypsum crystals was over or rather at the end. Only

rare and very small aggregates of euhedral calcite and skeleton dolomite had the possibility to develop in phreatic conditions and they have been found inside the oxides-hydroxides deposits. The phreatic development of these two carbonates is due to the fact that the thermal waters have always been slightly oversaturated with respect to gypsum and have had a rather high Mg concentration. Therefore, when biogenic reactions ruling the oxidizing processes generated some CO₂ (VASCONCELOS et al., 1995), the solution became supersaturated with respect to calcite and/or dolomite. Azurrite (Cu₃(CO₃)₂(OH)₂) was found only in the karst fractures of the -150 level, where it is present as thin crusts on top of some stalactites made of a complex aggregate of copper sulphates, which represent the source for Cu ions. Malachite (Cu₂(CO₃)(OH)₂) has been observed only in the +50 cave, where the lack of gypsum crystals testifies that the thermal water left this cavity a long time ago. Only this cave displays gravitational calcite speleothems and malachite was found just below one small calcite flowstone: its genesis is clearly related to the meteoric oxidation of chalcopyrite dispersed in the hosting rock. Calcite, aragonite and dolomite have been found in Cueva de las Espadas (-120 level) and in Ojo de la Reina and Cueva de las Velas (-290 level). In the last two caves the carbonate deposition is very recent being strictly related to mine dewatering. In fact, the presence of an atmosphere allows for condensation and the CO₂-rich condensed water reacts with both gypsum crystals and limestone walls thus inducing the deposition of these three carbonates. By far more interesting is the development of calcite speleothems, aragonite and gypsum occurring in the lowest part of the Cueva de las Espadas, where it is evident that a small thermal lake lasted for a rather long time, until a few years before the beginning of the mining activities, when meteoric water replaced the thermal regime. The upper flanks of the lake are covered by transparent gypsum crystals with several thin white crusts both outside and inside, which are composed mainly of aragonite with smaller parts consisting of different minerals (celestine, dolomite, apatite-group, halite and an Al, Mg, Cu, Zn silicate still under study)

2.3 Minerals developed in aerate conditions

The complete dewatering of the caves did not represent the end of the minerogenetic processes, which were characterized by a last stage active in all the cavities. The presence of an atmosphere gave rise to the evolution of several new diagenetic minerals. Nine minerals have been already cited which formed and/or are still forming in contact with the cave atmosphere: 5 carbonates (azurrite, calcite, aragonite, dolomite, and malachite), two sulphates (gypsum and celestine), one halide (fluorite) and one hydroxide (göthite). Beside them another 26 minerals exist, the genesis of which is confined to the aerated zone.

The largest group is represented by sulphates with 16 minerals: anglesite (PbSO_4), anhydrite (CaSO_4) antlerite ($\text{Cu}_3(\text{SO}_4)(\text{OH})_4$), bassanite ($\text{CaSO}_4 \cdot 1/2\text{H}_2\text{O}$), blödite ($\text{Na}_2\text{Mg}(\text{SO}_4)_2 \cdot 4\text{H}_2\text{O}$), chalcantite ($\text{CuSO}_4 \cdot 5\text{H}_2\text{O}$), Cu-rich variety of pentahydrate ($\text{Mg}_{0.45}\text{Cu}_{0.55}\text{SO}_4 \cdot 5\text{H}_2\text{O}$), epsomite ($\text{MgSO}_4 \cdot 7\text{H}_2\text{O}$), hexahydrate ($\text{MgSO}_4 \cdot 6\text{H}_2\text{O}$), jarosite ($\text{KFe}^{3+}_3(\text{SO}_4)_2(\text{OH})_6$), kieserite ($\text{MgSO}_4 \cdot \text{H}_2\text{O}$), plumbojarosite ($\text{PbFe}^{3+}_6(\text{SO}_4)_4(\text{OH})_{12}$), rozenite ($\text{FeSO}_4 \cdot 4\text{H}_2\text{O}$), starkeyite ($\text{MgSO}_4 \cdot 4\text{H}_2\text{O}$), szmikite ($\text{MnSO}_4 \cdot \text{H}_2\text{O}$), szmolnokite ($\text{FeSO}_4 \cdot \text{H}_2\text{O}$). Six of these (antlerite, Cu-pentahydrate, plumbojarosite, starkeyite, szmikite, szmolnokite) are here cited for the first time as cave minerals. The presence of nine metallic sulphates (anglesite, antlerite, chalcantite, jarosite, Cu-pentahydrate, plumbojarosite, rozenite, szmikite and szmolnokite) is the direct consequence of the oxidation of the poly-sulphides dispersed in the host rock. The EDAX analyses of the Cu-pentahydrate puts in evidence the presence of rather high values of Zn thus suggesting that element may have substituted Cu in its crystal lattice giving rise to a Cu-Zn-pentahydrate. The presence of bassanite may have resulted from the relatively high temperature of the rock and the high salinity of the feeding solution. The small and/or extremely small volumes of water involved in the growing process surely enhanced the possibility for these minerals to develop. In fact, all these processes are active only over the cave walls where these are covered by a thin layer of condensation water without flowing or dripping. Therefore evaporation, induced by the mine forced ventilation, is the only active process which is able to induce supersaturation with respect to these minerals. The presence of the other five sulphates (blödite, epsomite, hexahydrate, kieserite and starkeyite) is not so easy to explain owing to their extremely high solubility and high magnesium content. They have been observed only as white powder just below the giant gypsum crystals which are actually undergoing strong condensation processes. The genesis of these hydrated magnesium sulphates is strictly related to the chemistry of the huge fluid inclusions trapped in the gypsum crystals. It has been demonstrated that the Na, K and Mg content (as chlorides) of the trapped waters may reach values greater than 60g/l (GAROFALO *et al.*, 2008). Therefore the dissolution of the gypsum crystals allowed some large fluid inclusions to lose its content dripping on the cave floor where the strong evaporation induced the magnesium sulphate to precipitate. The same mechanism is responsible for the development of the rare halite (NaCl) crystals. Beside ubiquitous göthite, hematite (Fe_2O_3), magnetite (Fe_3O_4), pyrolusite (MnO_2), and woodruffite $\text{Zn}_{2.8}[(\text{Mn}^{4+})_{8.4}(\text{Mn}^{3+})_{5.6}]\text{O}_{28} \cdot 9.5\text{H}_2\text{O}$ (first occurrence in a cave) have been detected in this environment. Their genesis are the same as the oxides-hydroxides developed in phreatic conditions, but in this case the process was completely abiotic. In no samples was it possible to detect

fossilized biogenic forms like those widespread in the phreatic samples. In addition, four silicates had the chance to grow in the aerated environment: chrysocolla [$(\text{Cu},\text{Al})_2\text{H}_2\text{Si}_2\text{O}_5(\text{OH})_4 \cdot n\text{H}_2\text{O}$], fraipontite [$(\text{Zn},\text{Cu},\text{Al})_3(\text{Si},\text{Al})_2\text{O}_5(\text{OH})_4$], orientite [$\text{Ca}_8\text{Mn}^{3+}_{10}(\text{SiO}_4)_3(\text{Si}_3\text{O}_{10})_3(\text{OH})_{10} \cdot 4\text{H}_2\text{O}$] ($\text{Ca}_2\text{Mn}_2 + \text{Mn}^{3+}_2\text{Si}_3\text{O}_{10}(\text{OH})_4$) (first cave occurrence) and a Mg-Zn silicate still under investigation. Fraipontite and chrysocolla were observed only in the +50 cave and their genesis is most probably related to acid water seepage within silicate formations always present in the highly tectonized areas of the mine. Orientite is the product of the hypersaline environment induced by the evaporation of Na, K, Mg chloride-rich waters in an acid context induced by the oxidation of the sulfides dispersed in the rock. Presently no hypothesis can be formulated on the genesis of the last and still unknown silicate. Finally apatite-group minerals [$\text{Ca}_5(\text{PO}_4)_3(\text{F},\text{OH},\text{Cl},\text{Sr})$] (BURKE, 2008) and guanina [$\text{C}_5\text{H}_3(\text{NH}_2)\text{N}_4\text{O}$] have been identified. Apatite is present as small inclusion within the gypsum crystals developed on the upper flanks of the thermal lake. The organic matter needed for its development probably was carried there by seepage of fresh water. Guanina was found in +50 cave and its genesis is clearly related to the presence of nests of birds inside the cave.

3. Final Remarks

Beside the +50 cave, which was drained hundreds of thousands of years ago, in all the other caves of Naica epiphreatic and/or aerated conditions were reached only very recently (a few hundred years for Cueva de las Espadas and some 20 years for the caves of the -290 level). Nevertheless it is evident that the presence of an atmosphere has been the element allowing for the development of the majority of cave minerals in Naica. Of a total of 40 minerals only four (coronadite, opal, quartz and hectorite) are those restricted to the deep phreatic environment, while other five (gypsum, göthite, celestite, calcite and dolomite), even if in very different quantities, are present in all the environments and therefore also in the deep phreatic one. Four (aragonite, apatite, fraipontite and the still-undetermined silicate) developed both in the epiphreatic and aerated environments, while over two-thirds of the cave minerals of Naica (28 out of 40) developed in the aerated one. The abundance of active minerogenetic processes within this environment (5 while in the other two they are only 3, see Table 1) is also confirmed by the presence of 10 new cave minerals, among which only one (hectorite) grew under phreatic conditions while the other 9 (antlerite, Cu-pentahydrate, orientite, plumbojarosite, starkeyite, smikite, szmolnokite, woodruffite and the still undetermined Mg, Zn-silicate) developed in direct contact with the cave atmosphere.

The major factors allowing the genesis of such a high number of

ENVIRONMENT	PROCESSES	CHEMICAL DEPOSITS	T° decrease
Vadose	Organic matter mineralization	Organic mineral & phosphates deposition	very fast
	CO ₂ diffusion	Calcite speleothem evolution	
	Acid aggression	Gypsum, metallic sulphate & silicate deposition	
	Inorganic oxidation	Oxide-hydroxide deposition	
	Evaporation	“sails” development, sulphate & halide deposition	
Epi-Phreatic	CO ₂ diffusion	Aragonite deposition	slow
Deep Phreatic	Organic oxidation	Oxide-hydroxide deposition & limestone corrosion	extremely slow
	Gypsum/anhydrite disequilibrium	Giant gypsum crystals & celestite development	

Table 1: Environmental control over the minerogenetic processes and related temperature variations (after FORTI 2009, modified).

minerals in a so short span of time were: 1- the small volumes of water involved (deriving only from condensation processes), 2- high temperatures (enhancing oxidizing processes) and 3- forced ventilation (enhancing evaporation). In these conditions even the extremely soluble salts, and those containing rare ions, had the possibility to form. In conclusion even if the Naica caves have been known until present only for their giant gypsum crystals, it is evident that they are also an exceptional mineralogical environment due to the number of hosted minerogenetic mechanisms, which alternated each other in time and the incredible variability in forming minerals.

Acknowledgments

The Authors thank Peñoles Company for allowing the access to the Naica Mine and for helping all the scientists involved in this program to perform their job inside the caves. The Authors also thank Electrolux, Napapijiri, GT-line, Garmont, Ferrino, Virtualgeo, Grotte di Castellana, Testo, Set In, GeD Cucine, Livenza Viaggi e Turismo for their technical and financial support to the research. The Authors thank Professor Bogdan Onac for supplying useful data on the presently accepted nomenclature and chemical formulas of some cave minerals.

References

- BERNABEI T., P. FORTI, and R. VILLASUSO (2007) A new type of gypsum crystal from Naica (Mexico). *International Journal of Speleology*, **36** (1), 23–30.
- BURKE E.A.J. (2008) Tidying up Mineral Names: an IMA-CNMNC scheme for suffixes, Hyphens and Diacritical marks. *The mineralogical records*, **39**(2), 131–135.
- BUTLER G.P. (1973) Strontium geochemistry of modern and ancient calcium sulphate minerals. In *The Persian Gulf* PULSER B.H. (Ed.), Springer-Verlag New York, 423–452.
- DEGOUTIN N. (1912) Les grottes a cristaux de gypse de Naica. *Societad Cientifica Antonio Alzate*, **32**, 35–38.
- FORTI P. (2007) - Studio della struttura interna di una stalagmite della Grotta delle Spade (Naica, Messico). *Grotte e Dintorni*, **6**, 13, 3–20.
- FORTI P. (2009) Genesis and evolution of the caves in the Naica Mine (Chihuahua, Mexico). *Zetschrift. Geomorf.* In press.
- FORTI P., E. GALLI, and A. ROSSI (2007) The mineralogical study on the Cueva de las Velas (Naica Mexico). *Acta Carsologica*, **36**(3), 379–388.
- FORTI P., E. GALLI, and A. ROSSI (2008) Il sistema Gesso-Anidrite-Calcite: nuovi dati dalle concrezioni della miniera di Naica (Messico) *Memorie dell'Istituto Italiano di Speleologia*, s.II, **19**, 324–334.
- FORTI P., E. GALLI, and A. ROSSI 2009 Le grotte di Naica: non solo giganteschi cristalli di gesso. *Rivista Italiana di Mineralogia* in press.
- FOSHAG W. (1927) The selenite caves of Naica, Mexico. *American Mineralogist*, **12**, 252–232.
- GARCÍA-RUIZ J.M., R. VILLASUSO, C. AYORA, A. CANALS, and F. OTÁLORA, (2007) The formation of natural gypsum megacrystals in Naica (Mexico). *Geology*, **35**(4), 327–330.
- GAROFALO P.S., M. FRICKER, D. GÜNTHER, A.M. MERCURI, M. LORETI, S.E. LAURITZEN, S.

- CONSTANTIN, B. CAPACCIONI, and P. FORTI (2009). A 50ka climatic control on the formation of the gigantic gypsum crystals of the Naica caves (Mexico) sent to *Science*.
- HILL C.A. and P. FORTI (1997) *Cave minerals of the World*. National Speleological Society, Huntsville, 464 pp.
- LAURITZEN S.E., S. CONSTANTIN, and P. FORTI (2007) - Chronology and growth rate of the Naica Gypsum Crystals in *Le Grotte di Naica: esplorazione, documentazione, ricerca*, P. Forti, (Ed), Bologna, 49–50.
- PANIERI G., P. FORTI, G. GASPAROTTO, and L. SOLIANI (2008) Studio delle inclusioni solide presenti nei cristalli di gesso della Grotta delle Spade (Naica, Messico). *Memorie dell'Istituto Italiano di Speleologia*, s. II, **19**, pp 335–343
- VASCONCELOS C., J.A. MCKENZIE, S. BERNASCONI, D. CRUJIC, and A. TIENS (1995) Microbial mediation as a possible mechanism for natural dolomite formation at low temperature. *Nature* **377**, 220–222.

ISOTOPIC INVESTIGATIONS ON GYPSUM DEPOSITS FROM CAVES IN CENTRAL ITALY

MARCO MENICHETTI¹, MIRONA IOANA CHIRIENCO², BOGDAN P. ONAC^{3,4}, SIMON BOTTRELL⁵

¹*Istituto di Scienze della Terra, Università di Urbino, I-61029 Urbino, Italy*

²*Department of Geology, University of Illinois at Urbana - Champaign, USA*

³*University of South Florida, Department of Geology, 4202 E. Fowler Ave., SCA 528, Tampa, FL 33620, USA*

⁴*"Babeş-Bolyai" University Cluj/"Emil Racoviţă" Institute of Speleology, Clinicilor 5, 400006 Cluj, Romania*

⁵*School of Earth and environment, The University of Leeds, Leeds LS2 9JT, UK*

Abstract

The main underground karst systems across central Italy are characterized by the presence of large gypsum deposits. Active microcrystalline gypsum deposition can be observed at present in several caves along those galleries that are close to the groundwater level, e.g., in the Grotta Grande del Vento - Grotta del Fiume underground karst system (Frasassi Gorge), as well as in the Acquasanta Terme (Southern Marche), and in the Saturnia caves in Tuscany. The reaction between the wall limestone and the sulfuric acid (resulting from oxidation of H₂S) is responsible for the deposition of gypsum along vadose galleries. Bacteria play an important and active role in the chemical redox processes that lead to gypsum deposition.

Large microcrystalline gypsum deposits are known from the Monte Cucco caves, especially in the Buca di Faggeto Tondo in the Apennines, in the Pozzi della Piana, and in Parrano caves, where these deposits fill more than 50% of the dry sections of the galleries. Gypsum occurs as wall crusts (a few centimeters thick) or as large masses of floor deposits (many cubic meters in volume). Centimeter-sized, re-crystallized selenite crystals are on the walls or within clay sediments.

The $\delta^{34}\text{S}$ values of cave gypsum deposits range between -15‰ and -20‰ in the Monte Cucco caves, from -1‰ to -20‰ in the Buca di Faggeto Tondo, and from -6‰ to -19‰ for the gypsum deposits in the Frasassi Gorge. In the lower part of the Grotta del Fiume the $\delta^{34}\text{S}$ values are between -6‰ and -10‰ with lighter values in the re-crystallized gypsum. In the mineralized groundwater $\delta^{34}\text{S}$ (in sulfate) vary from +19‰ to +21‰, while $\delta^{34}\text{S}$ in native sulfur is -14.3‰, which is close to the values of the forming gypsum. The origin of gypsum is related to the oxidation of H₂S released from the groundwater. The different $\delta^{34}\text{S}$ values within the same deposits are most probably due to the isotopic fractionation associated with bacterial sulfate reduction in the presence of organic matter.

PRELIMINARY DATA ON MINERALOGICAL ASPECTS OF CAVE RIMS AND VENTS IN COVA DES PAS DE VALLGORNERA, MALLORCA.

ANTONI MERINO^{1,2}, JOAN J. FORNÓS¹, BOGDAN P. ONAC^{3,4}

¹*Departament de Ciències de la Terra, Universitat de les Illes Balears, Spain*

²*Federació Balear d'Espeleologia, C/ Margarida Xirgú, 16. 07011 Palma de Mallorca, Spain*

³*Department of Geology, University of South Florida, 4202 E. Fowler Ave., SCA 528, Tampa, FL 33620, USA*

⁴*"Babeş-Bolyai" University Cluj/"Emil Racoviţă" Institute of Speleology, Clinicilor 5, 400006 Cluj, Romania*

Located in the southern part of the island of Mallorca, on upper Miocene limestones, the Cova des Pas de Vallgornera is an exceptional coastal cave because of its length, presence of speleothems, and particular morphological features. Its morphological assemblage illustrates the key-role of geological factors in its genesis. It contains evidence of complex speleogenetic processes including, besides the typical coastal karstification, a noticeable meteoric water recharge along with a possible basal, deep (?) recharge of hypogenic origin. Related to the latter origin there are some conspicuous upward rising solutional channels. A series of morphologies interpreted as vents show associated and related speleothems such as crusts and cave rims. Rims occur around the lips of the holes and cracks on the galleries' floor. The genesis of these speleothems closely relates to their location in the upper maze area of the cave, just above the water-table level. Airflow from the lower level (in contact with the water table which supplies moisture to that air) to the upper level can cause the development of these rims. The chemical composition, as well as the diverse mineralogy observed, point to a hypogenic influence into the crusts and cave rims' genesis related to the vent morphologies. Apart from the common carbonate minerals present in the Mallorcan cave environment, the vast majority are rare (monohydrocalcite, strontianite, celestine, siderite, todorokite, and various clay minerals) or completely unexpected (barite, nordstrandite, maghmite, and paralstonite). Given the monotonous surface geology around the cave we suspect that ascending Sr, Ba, Mn, and Al-rich hypogene solutions react with the host rock to form this unique mineral assemblage. Iron can be leached from the surface or from the limestone.

1. Introduction

Cova des Pas de Vallgornera is located on the coast of Mallorca Island (western Mediterranean) and is an extensive maze cave partially drowned by brackish phreatic waters. The cave lies in the natural area of Migjorn, a littoral karst region forming a tabular platform built up by an Upper Miocene (Tortonian-Messinian) reefal limestone sequence (Fig. 1). Until very recently, because of the morphologies present in the known-section of the cave, the speleogenesis of the cave was exclusively related to dissolution in the freshwater-seawater mixing zone (GINÉS and GINÉS, 1992; GRÀCIA et al., 2006). In 2004, a major breakthrough was achieved during which extensive new passages and breakdown chambers were discovered. The former 6,400-meter extension of the cave turned into 59,000 m at the end of 2008 (MERINO et al., 2006, 2007, 2008). In the light of those discoveries, new and complex evidence of an extremely complicated genesis are being revealed. Apart from the dissolution in the freshwater-seawater mixing zones, large quantities of allochthonous infillings have been found and are related to the influence of surface recharge. Moreover, fresh morphological features

exhibited in the new sections of the cave (rising channels, ceiling channels, feeders, etc.), may well be tangible evidence of hypogenic processes (GINÉS et al., 2008). Interestingly, MERINO (2006) described the cave rims for the first time in Mallorca and made quite clear their relation to air convection between different levels of the cave.

The aim of this paper is to outline the presence of vents and rims along with a variety of minerals in the Cova des Pas de Vallgornera. X-ray analysis, EDX, and SEM observations of these related speleothems represent one of the main goals of the present work leading to the general description of the mineralogical aspects of the cave. Although at its early stage, this research suggests that the occurrence of these speleothems represents an adequate record of the genesis and evolution of the cave and therefore must be methodically sifted through.

2. Cave Rims and Vents

Cave rims and vents (Fig. 2) have been identified at some locations along the floor of Sector F, Galeria de les Toberes, Galeria d'en Pau, Sector Nord, and Galeria del Tragus so

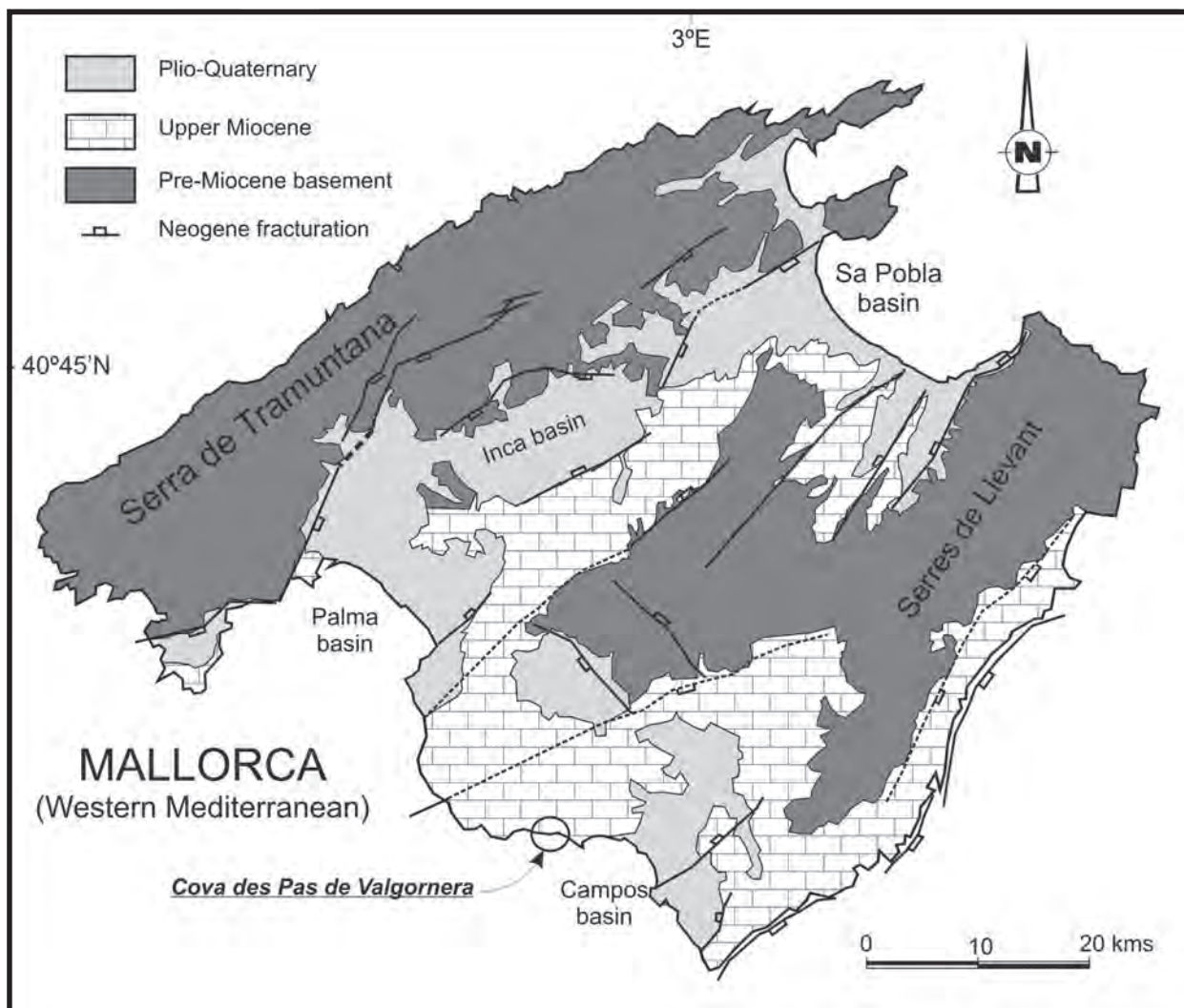

Figure 1: Simplified geological map of Mallorca Island showing the location of Cova des Pas de Valgornera.

far, but are likely to be found anywhere in the cave. Cave rim morphology resembles a shell; i.e., both sides of these projections are strikingly different. While the outside is rough and coralline, the inside is smooth, like the inside of the tube below the rim. Small and whitish crystallizations on the rim's edge have been spotted. Rims occur around the lips of the holes and cracks on the galleries' floor. They are colored white and reach a thickness of 1 to 4 cm. It appears reasonable to consider that these speleothems, mainly located in the upper maze area of the cave, just above another level which is at the water-table level, clearly relate to the cave's genesis. The rims are normally located at the top of another morphological feature called vents. Generally, a vent is a narrow inaccessible passage that links two different levels of galleries. Its walls are smooth and covered by weathered limestone and mineral deposits. The nearby areas of the vents normally show some mineral crusts and scattered mineralizations on the bedrock.

The vent that is described in this paper (Fig. 3) is located on the northwest side of Galeria del Tragus. A survey of this morphological feature was conducted in order to better document the distribution of minerals and deposits. As a whole, the cave is an irregular narrow low-roofed passage oriented northeast-southwest; its length is about 9 m and the maximum width 2 m. The short gallery has been dissolved on a tight joint that can clearly be seen along the floor, which is covered with small rocks. Commonly, the walls are characterized by uneven surfaces; the one situated at the northwest side shows a narrow shelf where sediments have been deposited along with some minerals. First of all, the ceiling shows an elongated smooth vault, which extends from the inner part of the vent to the outermost section, close to the main passage. Secondly, the central section shows a higher vaulted roof whose walls are covered with small ceiling pockets. Above the entrance to the vent, an enigmatic conduit, like a chimney connects the main gallery

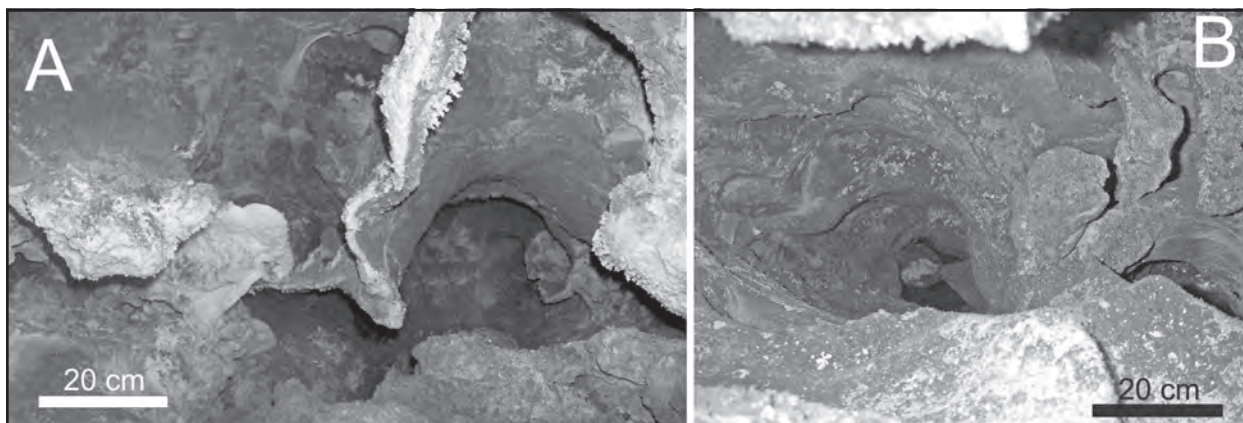

Figure 2: Innermost section of the vent (840–841), showing the walls and ceiling densely covered in multicolored deposits.

with impassable tubes that are likely to reach the vaulted roof mentioned before.

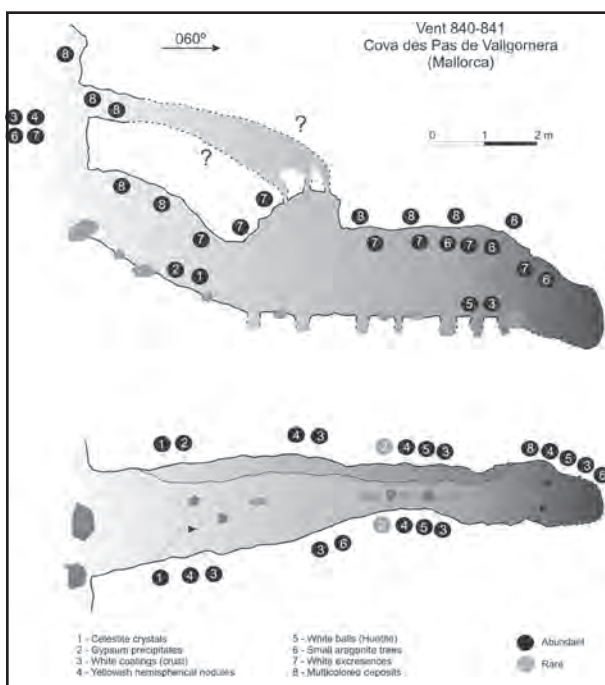

Figure 3: Vent sketch with the distribution of the main mineral facies present.

3. Chemical Composition and Mineralogy

The chemical composition as well as the main minerals observed point, to some extent, toward a hypogenic influence on the crusts and cave rims' genesis related to the vent morphologies. In fact, the investigated rims and vent walls from Vallgornera Cave show an interesting and diverse chemical composition. Apart from the common chemical components present in most of the speleothem caves in Mallorca (Ca^{2+} , Mg^{2+} , Fe^{3+} , Al^{3+} , Mn^{2+} , P^{5+}), there are some components that have never been documented in any other investigated cave on the island. The presence of

the less common S^{3+} , Si^{4+} , K^+ , Sr^{2+} , or even Ti^{4+} , Ni^{2+} , Zr^{4+} , Cu^{2+} , Cr^{3+} , Ba^{2+} , and La in different proportions suggests a geothermal origin for the minerals that can be found in the Pas de Vallgornera Cave vent-related speleothems.

The mineral deposits are mainly distributed on the vent's roof and walls, among which the multicolored layered deposits are abundant and should be emphasized (Fig. 4). They occur like an extremely fluffy and porous mesh with a thickness of about 5 mm, exhibiting changes in color from yellowish, greenish, grayish to red (multicolored deposits). When rubbed between the fingers, the deposit feels like peanut butter. Below this deposit, a second layer that is about 4 mm thick exists and usually consists of heavily altered limestone. Sometimes filamental forms can be seen hanging from the roof; when they fall off the ceiling, a multicolored deposit is present on the shelves and floor beneath the ceiling. A great deal of these deposits utterly covers the walls and roof of the vent's innermost section, whereas it is less abundant in the outermost portion, being chiefly concentrated on the elongated vault.

Some of the mineral species related to the vents, identified by means of X-ray diffraction, are also common within the Mallorcan cave environment (e.g., calcite, aragonite, gypsum or goethite; ONAC et al., 2005). However, the vast majority are rare: strontianite (Fig. 5A), huntite (Fig. 5B), monohydrocalcite, siderite, todorokite, celestine, and various clay minerals; or completely unexpected: barite, nordstrandite (Fig. 5C), maghmite, and paralstonite.

Another mineral is a whitish crystalline excrencence, wart-shaped, that protrudes from the roof, generally along the elongated vault or on the edge of the abundant roof irregularities. Isolated crystals may form at different locations; some of them have grown surrounded by the multicolored deposits. Occasionally, when a massive number

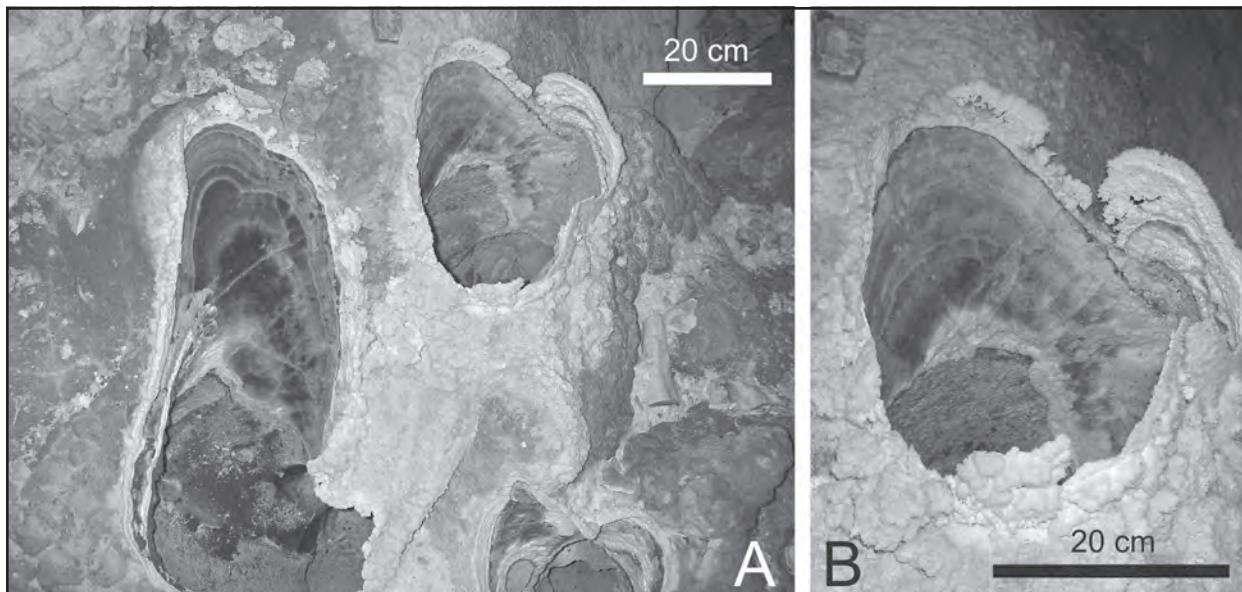

Figure 4: General aspects of large vent related rims; (A) group of three cave rims developed on the gallery's floor; (B) cave rim showing in detail the white crystallizations.

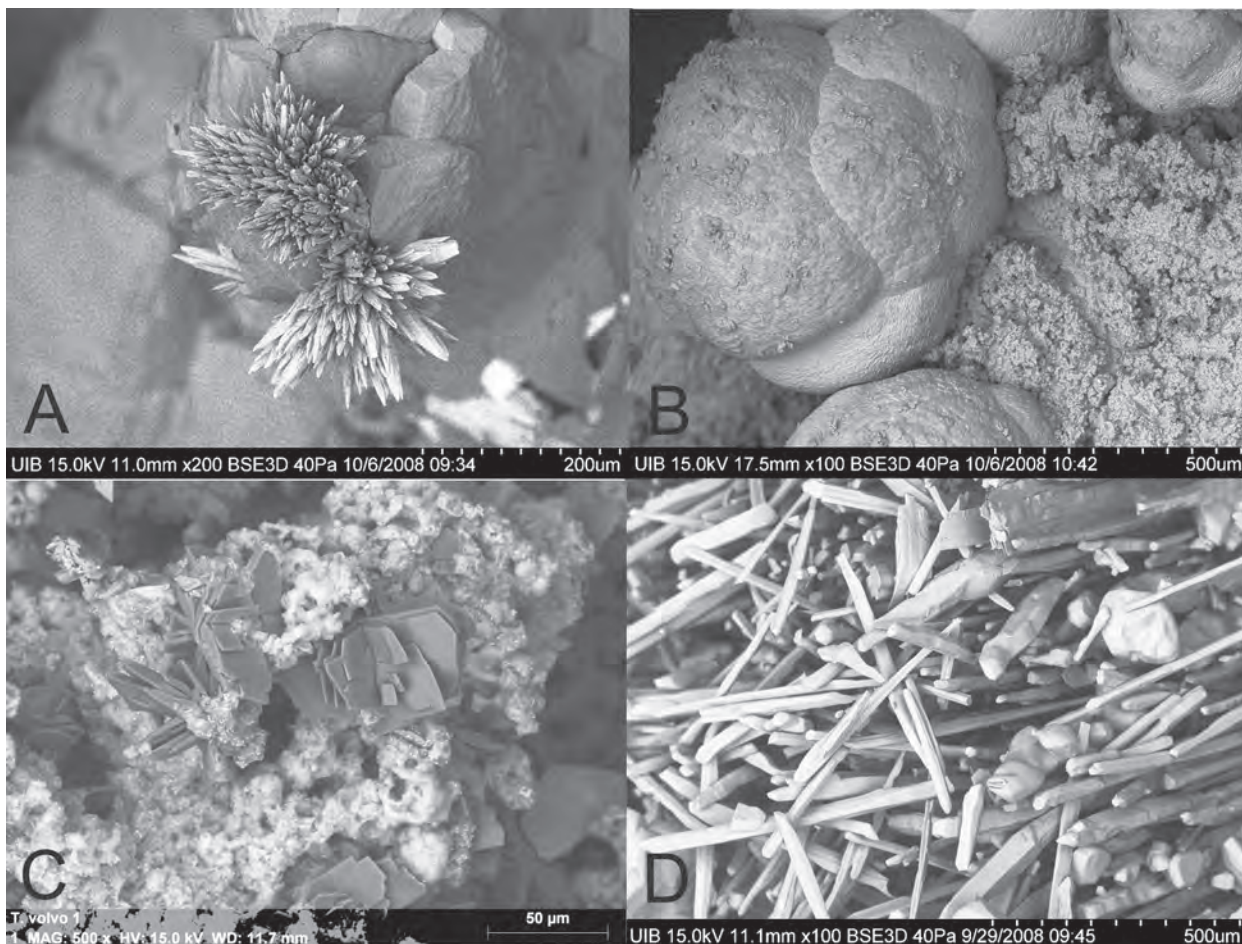

Figure 5: SEM images of some minerals present in the cave rims and vents of Cova des Pas de Vallgornera: (A) strontianite, (B) huntite, (C) nordstrandite, and (D) gypsum needles.

of crystals grow close to each other, a continuous and even mineral crust occurs.

As far as the mineralization that covers the shelves and walls, white crusts occur with an uneven surface. Yellowish hemispherical nodules made up of small crystals can sometimes occur over these crusts. At the same time, a small mass of white mineral covers the tips of those crystals. On some sites, an accumulation of such snow-white mineral aggregates (white balls) can be found coating the lower part of the walls where the nodules and white crust have developed this specific mineralization.

On the outermost third of the vent, tiny well-formed transparent celestine crystals are located mainly on the wall bedrock. They are present as groups of crystals formed by dozens of individuals whose lengths are less than 1 mm. Gypsum has also been found in this section of the vent (Fig. 5D), where it usually forms fibrous crystals along with saccharoid deposits, but as small gypsum flowers as well. These speleothems have grown on the shelf and also on sediments that cover the vent's floor. Gypsum crystals having celestine crystals in their neighborhood have been observed on the northwest side of the vent.

Small bunches of acicular aragonite crystals resembling trees are displayed on the roof and walls throughout the vent; however, they are not abundant.

Finally, the white mineral crusts (white coatings) that form the rims must be mentioned, although we are at an early stage of the research. Their occurrence suggests that they represent fundamental evidence of the vents' genesis and evolution and they must be methodically sifted through.

4. Conclusions

Chemical composition as well as the main minerals observed in Cova des Pas de Valgornera, to some extent, point to a hypogenic influence on the crusts and cave rims genesis related to the vent morphologies. Given the monotonous surface geology around the cave we suspect that ascending Sr, Ba, Mn, and Al-rich hypogene solutions react with the host rock to form this unique mineral assemblage. Iron was probably leached from surface or from the limestone. Additional mineralogical and hydrochemical studies need to be conducted in order to better document the existence of mixed convection processes related to rising flow paths within the Vallgornera region.

Acknowledgements

These investigations were supported by the research project

CGL2006-11242-C03-01/BTE of the Ministerio de Ciencia e Innovación – FEDER. We are grateful to the following colleagues for their contribution during the field work: Toni Mulet, Guiem Mulet, Joaquín Ginés, Anders Kristofersson, and Toni Croix. A special note of thanks must be extended to Conselleria de Medi Ambient, Govern Balear, particularly to Margalida Femenía for having granted the permits to carry out the research.

References

- GINÉS, A. and J. GINÉS (1992) Las Coves del Drac (Manacor, Mallorca). Apuntes históricos y espeleogenéticos. *Endins*, **17–18**, 5–20.
- GINÉS, J., A. GINÉS, J.J. FORNÓS, F. GRÀCIA, and A. MERINO (2008) Noves observacions sobre l'espeleogènesi en el Migjorn de Mallorca: Els condicionants litològics en alguns grans sistemes subterranis litorals. *Endins*, **32**, 49–79.
- GRÀCIA, F., B. CLAMOR, J.J. FORNÓS, D. JAUME, and M. FEBRER (2006) El sistema Pirata - Pont - Piqueta (Manacor, Mallorca): geomorfologia, espeleogènesi, hidrologia, sedimentologia i fauna. *Endins*, **29**, 25–64.
- MERINO, A. (2006) Espeleotemas poco frecuentes y morfologías de corrosión hallados en la Cova des Pas de Vallgornera. *Endins*, **30**, 49–70.
- MERINO, A., A. MULET, and G. MULET (2006) La Cova des Pas de Vallgornera: 23 kilómetros de desarrollo topografiado (Llucmajor, Mallorca). *Endins*, **30**, 29–48.
- MERINO, A., A. MULET, G. MULET, A. CROIX, and F. GRÀCIA (2007) La Cova des Pas de Vallgornera (Llucmajor, Mallorca): 40 kilómetros de desarrollo topografiado. *Endins*, **31**, 101–110.
- MERINO, A., A. MULET, G. MULET, A. CROIX, and F. GRÀCIA (2008) La Cova des Pas de Vallgornera (Llucmajor, Mallorca) alcanza los 55 kilómetros de desarrollo topográfico. *Endins*, **32**, 33–42.
- ONAC, B.P., J.J. FORNÓS, A. GINÉS, and J. GINÉS (2005) Mineralogical reconnaissance of caves from Mallorca Island. *Endins*, **27**, 131–140.

MINERALOGY OF CHEMICAL DEPOSITS IN HYPOGENIC PHISEUA CAVE, KHAMMOUANE, CENTRAL LAOS

CLAUDE MOURET and PHILIPPE LAPOINTE

TOTAL SA, 2 Place Jean Millier, F - 92078 Paris-La Défense, France,

claude.mouret@total.com; philippe.lapointe@total.com

Phiseua Cave is longer than 13 km, with a vertical elevation difference of +465 m, the largest relative cave vertical elevation difference in Laos. It is an exceptional cave, with extensive fossil maze passages (>10 km) and uncommon cave minerals. The fossil passage system has developed along bedding planes in massive Permo-Carboniferous carbonate beds that dip around 20 degrees to the West. Main passages are somewhat sinuous or angular as they are oriented either close to the dip direction or close to the strike, with some oblique directions. In many places, they connect very complicated lateral mazes of smaller galleries. These mazes are mostly developed within a 10 to 20 m thick dipping interval broadly parallel to the bedding planes and main passages. Such mazes are mainly two-dimensional, but locally they are three-dimensional. All fossil passages clearly show phreatic morphology and effects of hydrodynamism over the entire cave system, including thousands of sloping cupolas broadly parallel to the bedding, fine to very fine-grained sands, silts and some clay deposits. Sinuous channels related to floor-deepening follow a number of secondary maze passages and probably formed during progressive lowering of the water table, during the incision of karst by the Mekong River and its tributaries. Straight incising of deeper passages, secant over all the others, represents late vadose features. The cave is hypogenic, as shown by characteristic phreatic features present over several hundred meters of elevation range and by the regular sediment grain size, all features that are incompatible with a meteoric origin.

Cave passages show a number of vents on the floor, around which specific mineral deposits, including rims, are located. Rare mineral deposits cover large places in the cave: hollow stalagmites with usually no corresponding stalactites, trays, huge quantity of mondmilch (moonmilk), gypsum crusts and crystals, apatite-(CaF) (formerly fluorapatite) crusts, etc.

Sampling of host rock, floor sediments, mondmilch and other speleothems was conducted in a cave-respectful way. It was aimed at determining the mineral species present, chronology of their deposition, and their areal distribution and specific occurrence (such as around fossil vents). Sawed sections and thin sections were prepared and studied macroscopically and under the microscope, both under natural and polarized light. X-ray powder diffraction analyses were carried out on clearly selected parts of the samples. Identified minerals are: calcite, dolomite, aragonite, siderite, gypsum, whitlockite, apatite-(CaF), apatite-(CaOH), hydromagnesite, magnesite, smectite, kaolinite, palygorskite, sepiolite, chlorite, goethite and quartz.

1. Introduction

The study of hypogenic caves, including hydrothermal caves, is more and more a present-day topic of investigation (HILL & FORTI, 1997). The need is real for a better characterization of karst voids, whether it is for scientific research or for industrial applications. First, it is necessary to prove the hypogenic or hydrothermal nature of a cave in order to exploit the knowledge of its 3D geometry. There is also a need for analogues or reference cases that can be used to guide further research on other karst voids.

In Central Laos, several caves show a number of original

characteristics, including geometry, morphology, sediments, and mineral deposits. Cave-respectful selective sampling has been conducted in order to look for minerals of hydrothermal origin. Here in this paper, an initial interpretation is offered based on a first batch of mineralogical analyses, mainly the X-ray diffraction analysis of 76 samples.

2. Geological and Karst Settings of Khammouane Area

Tham Phiseua is located in Permo-Carboniferous carbonates, which consist of dominant dolomitic limestone

to limy dolostone, dolomite, and limestone. The thickness of the carbonate sequence is estimated at 1100 m. The outcrop area in Laos is 290 km long and 40 km wide. It is overall NW-SE trending and it is bounded to the SW by the Thakhek Fault Zone, a major wrench fault in Southeast Asia. Many parallel faults are present along the heavily karstified carbonate (MOURET, 1994, 2001, 2005). Karstification has a long history in the area (tens of millions of years). It is related to the orogenesis of Southeast Asia, with a concomitant relative base level fall. The current base level is the Mekong River at around 145 m a.s.l. The erosion thickness is huge - much in excess of 1 km - and the karst has been progressively denudated from its siliciclastic enveloping formations (which were located above it and next to it along the Thakhek Fault Zone).

Karst is widespread in Khammouane. Many of the caves are subhorizontal. However, during the six previous years, a clear occurrence of caves with a huge slope component has been proved. These caves show passage networks, which are bearing a varying degree of geometric complexity and can even encompass complicate mazes. Tham Phiseua is the most impressive example, with passages gradually rising up to + 465 m above the lower entrance. These passages gently follow sets of bedding planes and at +465 m are cut through by surface erosion. It is estimated, based on apatite fission tracks analysis and other methods, that the sloping part of the cave was active during the Late Miocene to Early Pliocene (MOURET, 2005) The passages in Tham Phiseua are often close to the bed strike direction or close to the dip (20° towards the west). Consequently, the cave network is comprised of a set of subhorizontal passages and of a set of sloping passages close to the structural dip. Passages with intermediate directions accordingly have intermediate slope.

3. Phiseua Cave

The passages in Phiseua Cave, where samples were collected (in a cave-respectful way), range in elevation from approximately 120 m to 350 m above the lower cave entrance. The relative elevation of the sampled passages are as follows, from the lower ones to the uppermost one : Gypsum, (to the) Right, Camp, Shortcut, Pirate, (Hole of the) Winds, Black, Reflector, Calcite, Fe, West and Upper (Fig. 1). Camp, Shortcut, Black, Reflector, Calcite and West are the main subhorizontal passages sampled. Gypsum Passage is subhorizontal only near the sampling points around a vent ; the rest of the passage is sloping. Passages: (to the) Right, Pirate (with rims), Upper, are close or relatively close to the dip. Hole of the Winds is a steep narrow way. Passage size is commonly 10 to 20 m large and 10 to 15 m high. In maze passages, width may be 2 to 3 m

and height around 3 m, though low passages exist as well (up to 30 m large and 1 m high). Tham Phiseua is hypogenic, as shown by morphological features (very abundant cupolas on the walls and at the ceiling, often with a tilted base parallel to the bedding surfaces), geometric features (some geometric settings can form only in a phreatic context), sorted sediments of usually fine-grained size, sedimentary features generated mainly by low velocity currents, and the several hundred meters of elevation with phreatic morphology.

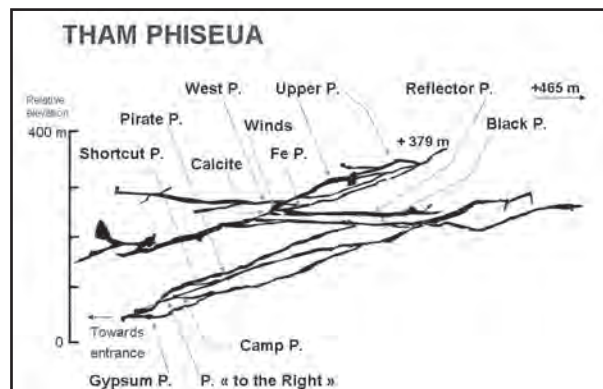

Figure 1: Schematic long cross-section of the sampled part of the hypogenic passages of Tham Phiseua (active subhorizontal levels are not shown).

Sampling was selective in order to obtain a representative, though necessarily limited, set aimed at characterizing the main types of mineral deposits (soft sediments and speleothems) and at taking into account all passages important to the understanding of cave development. Some samples also come from Tham Koun Dôn and from Tham Lô, two other major caves in Khammouane with similarities to Tham Phiseua. These caves were sampled for more information and comparison.

4. Mineralogical Contents

4.1. Soft sediments

All of the 7 sediment samples from Upper, Reflector, Black, Shortcut and Gypsum Passages, (Fig. 2) show dominant calcite (1 to 75%), and dolomite (up to 56%). The average calcite + dolomite content is 64% and the standard deviation is 22%. Aragonite is present in 3 samples (43% of the samples), but it does not exceed 25%. Quartz is present in 3 samples, up to 11%. In another one, it reaches 49%: this last quartz-rich sample is the only one with smectite (18% of it). The sample with 11% of quartz has 50% of calcite + dolomite, no aragonite, 27% of kaolinite and 12% of chlorite. In one sample (Reflector Passage), palygorskite (24%) is associated with sepiolite (7%), aragonite, a small amount of calcite and dominant dolomite (56%). All samples have a dominant carbonate fraction (66% in

average), no or little quartz though sometimes in a large amount. The quartz, where it is present, is associated either with carbonate minerals only, or also with clay minerals (smectite or kaolinite + chlorite). Sepiolite (46%) is associated with calcite and dolomite only. Clay minerals amount to 31 to 46%, if they are present. The average composition of the 7 samples is: carbonate: 71%, quartz: 10% and clay minerals: 19%. This composition is typical of autochthonous sediments, with a high amount of carbonate having the same components as the hosting rock (dolomitic limestone and dolomite) and mineral deposits (calcite, dolomite, aragonite). Quartz is probably derived from silicified parts of the rock or from diagenetic cherts. The clay minerals are from three subhorizontal passages: Reflector, Black, and Shortcut.

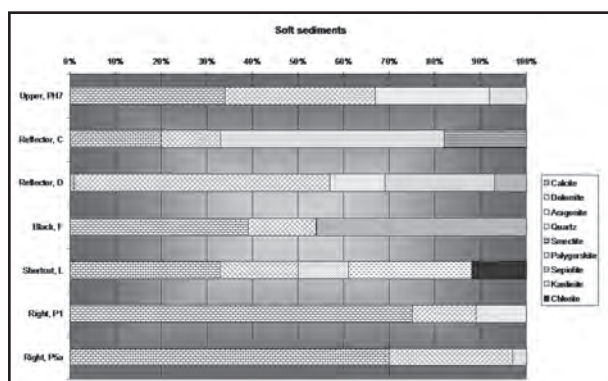

Figure 2: Soft sediments composition (text along ordinates: Name of passage, sample number, comment).

4.2. Flowstones

Among the oldest deposits in the cave are the banded carbonate flowstones showing kink laminae (Calcite and Reflector Passages). Coarse grains and small pebbles of quartz are occasionally included as thin layers. Until further information is obtained, they are interpreted as originating from the host rock. One sample contains dominant calcite and dolomite; two samples are fully calcite, with traces of quartz. Another one contains 55% of sepiolite with 36% calcite and 9% dolomite. Calcite is always largely dominant over dolomite. Aragonite is not present, unlike in later flowstones (29% measured). A subcircular deposit along the top rim of a pothole open at the bottom shows 76% calcite, 18% dolomite and 6% quartz.

4.3. Vent and rim areas

Vents are holes in the passage floor, usually narrow, which continue below, becoming wider at some depths. Vents are not vertical shafts. Around the vents, there is a deposition of specific minerals, as detailed below. Rims are hollow speleothems with an axial hole often 10 to 15 cm in

diameter, rimmed by thin subvertical walls of around 1 cm. Their heights are often a few centimeters, but are up to 10 cm in Tham Phiseua, and are even of more height in other caves. The walls of rims are always thin in comparison with the large axial hole that they surround.

Rims are present in Pirate Passage while vents are more specifically encountered in the lowest part of Gypsum Passage. All 8 samples studied are composed of calcite, varying from 2 to 63%. In the lowest vent area, calcite is 1 to 7%, while aragonite is largely dominant (65 to 90%). Dolomite ranges from 9 to 30%. There is some quartz (0 to 5%). A low rimstone dam, one or two meters away from the vents, shows a similar composition, but a protruding, fibro-radial mushroom-shaped speleothem in the vent is very different, being mainly made up of calcite, with a small amount of dolomite and of quartz. The rim sampled in Pirate Passage shows 50 to 62% of calcite, associated with 30 to 45% of aragonite and either some dolomite or some gypsum. A bush-like small speleothem (<5 cm long) from the passage ceiling in the same area is different: with dominant calcite (63%), dolomite (30%) and a small amount of quartz. Clearly, calcite and aragonite are the main minerals, with some dolomite and occasional quartz. The composition of the bush-like small speleothem is comparable with the protrusion in the vent.

4.4. Hollow stalagmites

Out of ten samples of hollow stalagmites collected from Tham Phiseua, all show aragonite (21 to 77%, average: 42%, standard deviation: 20%). 9 samples show calcite (17 to 77%, average: 49%; standard deviation: 22). Gypsum, the third mineral, is present in 2 samples, however between 57 and 68%. 2 samples have 3 to 5% of dolomite. One has 1% of siderite. For comparison, hollow stalagmites from Tham Koun Dôn show only calcite (4 to 68%, av.: 34%, st. dev.: 27%) and aragonite (avg.: 66%), in highly varying proportions. Apparently similar speleothems from Tham Lô are made up of calcite associated with only 1 to 3% of quartz. This indicates that hollow stalagmites may show rather different compositions from one cave to another. This needs to be investigated in more detail.

4.5. Massive stalactites

In the upper part of Tham Phiseua, at around +320 to +350 m of elevation relative to the entrance, exist several massive stalactites of the "elephant foot" variety or as subrounded bowls which can reach around 1 m in diameter. X-ray diffraction pattern shows that their composition varies from 50% of calcite and 50% of aragonite to 100% calcite in one single stalactite. Quartz is present as minor quantities (1% in

two samples out of 4).

4.6. Wall stalagmite

One wall stalagmite has been sampled. Its location is around 1.3 m high along the “Fe Passage” wall at a similar elevation as West Passage. This approximately 5-cm long speleothem is whitish inside but is covered with a thin dark brown crust. The measured composition on 2 microsamples of the stalagmite is 0 to 21% of dolomite, 5 to 8% of aragonite, the rest being hydromagnesite. The crust has not been analysed, but it likely has a similar mineralogical nature as the crusts in West Passage (see below).

4.

This passage shows the following succession: 1. carbonate cave wall, subsequently altered ; 2. brown crust on the walls and on the ceiling, obliterating cupolas ; 3. light cream-colored rock foam along the walls up to near the ceiling ; 4 : stalagmites ; 5 : mondmilch in huge quantity on the floor (around 30 to 50 cm thick) ; 6 : hard white crust on the mondmilch. The crust is apatite-(CaF) (formerly fluorapatite) (Fig. 3), with occasionally some calcite and minor dolomite, which may come either from the altered, powdery, cave wall or from internal laminae. In Pirate Passage, similar crusts are entirely apatite-(CaF) (100%) and one crust sample from the ceiling also shows dolomite. The “rock foam” is calcite (41%) and aragonite. The mondmilch is either grey (95% hydromagnesite and 5% dolomite) or white (62% hydromagnesite, 37% dolomite, 2% aragonite). The crust is gypsum. Gypsum flowers are encountered on the floor of a nearby passage.

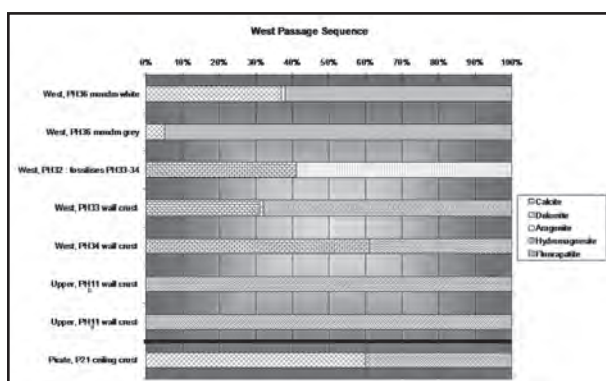

Figure 3: Mineral succession of the main phases (younger on top) in West Passage.

4.8. Crusts with whitlockite

Whitish crusts considered in the cave as gypsum crusts have been analysed. They show only 58 to 76% of gypsum (average 68%), and they include 3 to 14% of quartz. The rest is whitlockite. All 4 samples with this mineral are located in

Gypsum Passage. All other samples of gypsum crusts from Tham Phiseua have proved to be 100% gypsum.

4.9. Mondmilch and “black and white” deposits

Tham Phiseua shows abundant deposits of mondmilch (moonmilk). They are located either on longitudinal slopes or in subhorizontal areas. In the first case, they are often located in the steeper part (Gypsum Passage, steep area near West Passage, and other passages not described here) and may form accumulations up to 1 m thick (Hole of the winds). In the second case, they form 30 to 50 cm thick deposits, as in West Passage or Reflector Passage. In the lower (in elevation) passages (Gypsum, Hole of the Winds), the mondmilch is composed entirely of hydromagnesite. In the higher passages (West, Upper), the 2 samples show largely dominant hydromagnesite and dolomite and, when dolomite content is high (37%) there is also 1% of aragonite. In Reflector Passage, 1 (only) sample of mondmilch is 65% dolomite and 35% sepiolite.

Black and white deposits are commonly associated with the mondmilch that they usually cover. However, their composition is rather different. Two microsamples from above the hydromagnesite of Gypsum Passage. show 48 to 56% of aragonite and 18 to 24% of calcite, associated with hydromagnesite (9 to 15%) and magnesite (11 to 19%). Above the hydromagnesite of the Hole of the Winds, there is aragonite (21 to 87%), dolomite (5 to 7%), and calcite (0 to 1%). Gypsum is present in both microsamples (7 to 69%). In the sample with 67% gypsum, there is 3% of quartz and no calcite.

5. Mineral Associations and Cave Origin

Several of the minerals present in the cave (Fig. 4) are rich in magnesium (as is the dolomitic host rock): dolomite, magnesite, hydromagnesite, palygorskite, and sepiolite. These minerals are compatible with an autochthonous origin. The origin of quartz remains to be investigated, though chert is rather common in the Permo-Carboniferous carbonates of Khammouane. Phosphate (apatite-(CaF), apatite-(CaOH), whitlockite) is usually interpreted in the literature as having been derived from guano. However, in one cave in Japan the phosphate has been interpreted as having originated from the host rock (KAMIYA et al., 1981 cited by HILL & FORTI, 1997, p. 170). Apatite-(CaOH) and apatite-(CaF) may deposit under hydrothermal conditions (ALPHONSO et al., 2005 ; CANET et al., 2003), including passages carrying hydrothermal fluids. Palygorskite is interpreted as a hydrothermal deposit in caves of Washington, USA (HILL & FORTI, 1997, p. 184). Sepiolite can be hydrothermal (HILL & FORTI, 1997, p. 363). Whitlockite is not known to deposit under hydrothermal conditions.

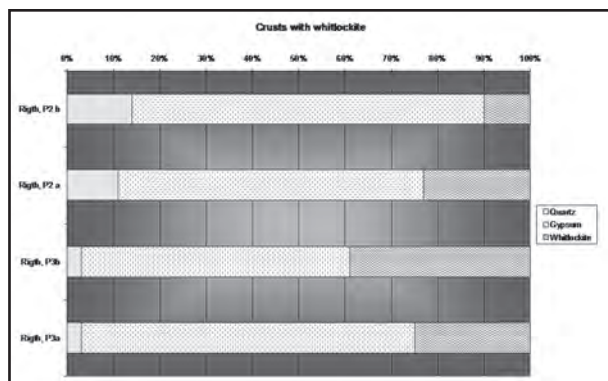

Figure 4: Mineral location in passages (top passages in top of table) and abundance (black: abundant ; medium grey: not so abundant ; lighter grey: small quantity). Note that abundance of each mineral is shown separately.

The hypogenic origin of the cave, though it is altered to a small degree by younger vadose features, is most likely phreatic, as explained above. Regarding a hydrothermal origin, there are a number of minerals that have been reported as depositing under hydrothermal conditions, though meteoric conditions are also reported for them in the literature. Some phosphate mineral deposits are reported as possibly related to guano located in passages above the studied passage. Guano leaching by drippings would generate stalactites of phosphate minerals and other kinds of speleothems (HILL & FORTI, 1997).

In Tham Phiseua, the numerous phreatic features are present over more than 250 m of elevational difference, the location of the cave near the Thakhek Fault Zone, and the presence of minerals of possible hydrothermal origin suggest a possible hydrothermal origin for the cave. This is also supported by the crusts of apatite-(CaOH)

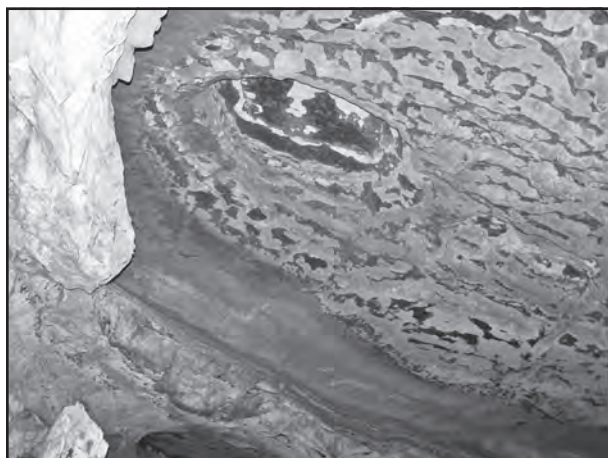

Figure 5: Phreatic cupolas tilted along the bedding planes (dip: around 20° towards the West) covered with crusts of apatite-(CaF) (fluorapatite). West Passage. Photo by J.F. Vacqu  .

and apatite-(CaF), which cover the entire section of some passages, including the full internal surface of cupolas and adjacent ceiling (Fig. 5). This interpretation still needs to be corroborated by studying fluid inclusions and isotopes.

7. Conclusion

The mineralogical study of Tham Phiseua tends to support the interpretation of a hydrothermal origin. Nevertheless, more studies are still necessary to confirm it. This kind of approach, putting together geology, regional evolution, karst and cave morphology, mineralogical studies, and any other possible method, is necessary to reach a definite conclusion. More detailed interpretations will be derived from further studies of the collected samples.

The detailed study of selected caves has a paramount importance to better understand hypogenic and hydrothermal karsts and also to use this knowledge for industrial applications, such as predicting the location of voids and their size and connectivity. It is also necessary to predict fluid-flow during their production from paleokarsts.

Acknowledgement

Many thanks are expressed to TOTAL SA for support during this study and to cave explorers who have assisted during long days of cave mapping and during sampling. Many thanks also to Laotian authorities and friends for their long lasting support.

References

- ALPHONSO, P., R.M. PROL-LEDESMA, C. CANET, J.C. MELGAREJO, E. FALLICK, 2005. Isotopic evidence for biogenic precipitation as a principal mineralization process in coastal gas hydrothermal vents, Punta Mita, Mexico. *Chemical Geology*, **224**, 113–121
- CANET, C., R.M. PROL-LEDESMA, J.C. MELGAREJO, A. REYES, 2003. Methane-related carbonates formed at submarine hydrothermal springs: a new setting for microbially-derived carbonates? *Marine Geology*, **199**, 245–261
- HILL, C.A. and P. FORTI, 1997. *Cave minerals of the world. USA*, 2nd Edition, National Speleological Society, 463 pp.
- MOURET, C. 1994. Geological evolution of Northeastern Thailand since the Carboniferous. Relations with

Indochina and Carboniferous to Cenozoic evolution model. Proceedings of the International Congress of Speleology. IGCP 306, Stratigr. Correl. of SE Asia, Bangkok, 15–20 Nov. 1994, Thailand, 132–158

MOURET, C. 2001. Le karst du Khammouane au Laos central. Spelunca Bull., Fr., 84, 7–32

MOURET, C. 2005 [available in 2008]. Main 2001 to early 2005 results on the karst of Khammouane, Central Laos. Greece, Athens, Proceedings of the Athens International Congress of Speleology, UIS , 2, Paper O-143, 4 pp.

MINERALOGICAL AND STABLE ISOTOPE INVESTIGATIONS OF MINERALS FROM CAVES ON CERNA VALLEY (ROMANIA)

BOGDAN P. ONAC^{1,2}, JONATHAN SUMRALL¹, TUDOR TĂMAȘ², CRISTINA CIZMAȘ²,
VERONICA DĂRMICEANU², IOAN POVARĂ³, LUCIAN NICOLIȚĂ⁴

¹University of South Florida, Dept. of Geology, 4202 E. Fowler Ave., SCA 528, Tampa, FL 33620, USA

²"Babeș-Bolyai" University Cluj/"Emil Racoviță" Institute of Speleology, Clinicilor 5, 400006 Cluj, Romania

³"Emil Racoviță" Institute of Speleology, Frumoasă 13, Bucharest, Romania

⁴Speleo Club "Prusik", Aleea Poiana Ruscăi 2/7, 300454 Timișoara, Romania

The caves from Cerna Valley, southwest Romania, are ideal for mineralogical studies because the reaction between hot ascending thermal water or steam with the bedrock or cave sediments enabled a number of minerogenic processes (e.g., replacement, steam-condensate weathering) that ultimately led to the deposition of a unique suite of cave minerals. The mineral species identified in caves along Cerna Valley are: calcite, aragonite, gypsum, anhydrite, epsomite, pickeringite, halotrichite, apjonite, tamaragite, alunite, aluminite, chalcantite, apatite-(CaOH), brushite, darapskite, and nitratine. Although the speleothems are not extremely spectacular, their mineralogy and stable isotope signature provides a wealth of information with respect to the environment in which they were precipitated. Combining this information with particular cave morphology observations, tectonic, and structural data, we document at least one episode of hypogenic activity within this karst area of Romania.

1. Introduction

Over the last three decades, a large number of caves affected by thermal and/or sulfide-rich solutions (either during their development or in later stages) have been documented. Without exceptions, all display a rich and diverse mineral association (POVARĂ et al., 1972; DIACONU and MEDEȘAN, 1973; CODY, 1978; HILL, 1987; MALTSEV and SELF, 1992; DUBLYANSKY, 1997; DuCHENE, 1997; MALTSEV, 1997; ONAC et al., 2000, 2001, 2007; ONAC, 2002; FORTI et al., 2006; AUDRA and HOBLÉA, 2007). HILL and FORTI (1997) and ONAC (2004, 2005) have shown that in complex cave settings (i.e., caves in the vicinity or within particular type of rocks, in the presence of hydrothermal waters or brines, etc.) the minerogenic processes are responsible for the precipitation of unusual minerals, which normally would not be encountered in any ordinary cave environment. The presence of such mineral species could be a diagnostic feature for hypogene speleogenesis.

A number of caves are known to develop in Mesozoic limestones that outcrops along Cerna Valley and its tributaries in southwestern Romania (Fig. 1). With the exception of Great Săltrari Cave (1.4 km total development) all the other cavities are short (less than 250 m in length). The Cerna Valley (especially in, and around the city of Băile Herculane) is well known for its thermal springs that were used therapeutically before the

Romans conquered Dacia (CRISTESCU, 1978). In the neighborhood of Băile Herculane, a number of caves such as Diana, Despicătură, and Hercules are currently under the influence of thermal waters, which either flow or pool in them. In other caves (e.g., Grotta cu Aburi and Avenul lui Adam) the thermal anomalies (cave air temperatures as high as 45° C) are related to the presence of hot steam that ascends along deep paths (faults, fractures, and voids along folded strata) (Figure 1). In addition, the thermal waters in a number of these caves are enriched in H₂S, and therefore, occurrences of large gypsum and other sulfate deposits (mainly crusts) are not unusual. Bat colonies and associated guano deposits are common in many caves of this region; the most unique one is Avenul lui Adam (Adam Shaft).

In this paper we provide a preliminary mineralogical survey based on our on-going studies in caves from the lower section of the Cerna Valley. All investigated caves are presently influenced by sulfide-rich thermal waters or ascending hot steam. Along with the description of the cave minerals, we also present the processes that ultimately led to their deposition and make assumptions about the relationship between specific mineral assemblages and possible hypogene processes.

2. Samples and Methods

About 30 mineral samples (mostly sulfates) were collected from five caves (Diana, Despicătură, Hercules, Adam, and

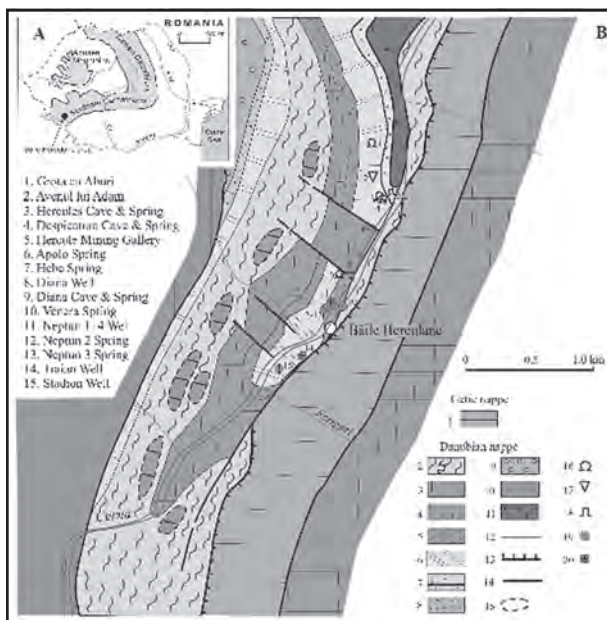

Figure 1: Geologic map of the lower Cerna Valley and location of sampled caves (from NĂSTĂSEANU, 1980); 1: schist (Sebeş-Lotru formation); 2: wildflysch (Upper Cretaceous); 3: Urgonian limestone (Barremian-Aptian); 4: marly-limestone (Iuta formation); 5: limestone (Valanginian-Hauterivian); 6: cherty limestone (Upper Jurassic); 7: detrital limestone (Middle Jurassic); 8: quartz sandstone (Upper Liasic); 9: conglomerate (Lower Liasic); 10: schist (Neamțu formation); 11: Cerna granite; 12: geologic boundary; 13: thrust; 14: fault line; 15: olistolith limit; 16: cave; 17: shaft; 18: mining gallery; 19: thermal water spring; 20: thermal water well.

Aburi) and the Hercule Mining Gallery, all situated on the western flank of Cerna Valley (Fig. 1). Visual inspection of all mineral specimens were made using a Nikon SMZ1500 stereo zoom microscope, equipped with a fiber-optic ring illuminator and a high-definition DS-5M standard CCD camera. Additional images were collected using a Hitachi S-3500N scanning electron microscope. Samples were routinely analyzed by means of X-ray powder diffraction (XRD) using a Rigaku MiniFlex II instrument at the Department of Geology, University of South Florida. Operating parameters were 30 kV and 15 mA using a Ni K β -filtered CuK α radiation. The patterns were collected using fixed 1.25° scattering slit and a 0.3 mm receiving slit. All samples were continuously scanned (speed was 0.5 and 1°/s) from 5 to 70° 2 θ with a fixed step size of 0.02° 2 θ per second. Silicon (NBS-640b) was used as the internal standard.

The Fourier-transformed infrared (FT-IR) spectra were recorded at room temperature using a Bruker Equinox 55 spectrometer (In-GaAs detector and KBr pellets) at “Babeş-Bolyai” University in Cluj. The spectral resolution was 4 cm

¹. Two hundred scans were accumulated. A Thermo Delta V Isotope Ratio Mass Spectrometer (IRMS) at University of South Florida Stable Isotope Lab was used to measure $\delta^{34}\text{S}$ values ($^{34}\text{S}/^{32}\text{S}$ ratio expressed in δ -notation) in water and mineral samples with a coupled Elemental Analysis (EA)-IRMS by conversion of S to SO₂. The method that this study used for continuous flow sulfur isotope analysis follows GRASSINEAU et al. (2001). The standards used for the analysis were IAEA S-2 and IAEA S-3 for sulfides and IAEA SO-5 and IAEA SO-6 for sulfates.

3. Results and Discussion

Prior to this report, only five minerals were identified in Diana, Despicătură, and Adam caves, all located in the lower section of the Cerna Valley (POVARĂ et al., 1972; DIACONU and MEDEȘAN, 1973; DIACONU, 1974). Our present study reinvestigated these caves along with three others adding seven more mineral species to the previous inventory, which now totals fourteen minerals. We will begin our presentation with the upstream caves and will end with the most complex one (Diana Cave), which lies just a few meters above Cerna Valley.

3.1 Grota cu Aburi (Steam Cave)

Steam Cave opens at 240 m above Cerna River's thalweg in the right cliff face of the valley (Figure 1, #1). The cavity is ~24 m in length and its single L-shaped gallery follows a minor fault line along which hot steam enters the cave at three different locations. Four crust samples were collected from this cavity; three from around steam vents and one from the far end of the gallery, below a seasonally occupied bat roost. This dark millimeter-sized brown crust consists of apatite-(CaOH) [Ca₅(PO₄)₃(OH)], formerly known as hydroxylapatite, a name that is no longer valid (BURKE, 2008). The other crust samples (also millimeter size, but light colored) are composed of either calcite [CaCO₃] or gypsum [CaSO₄·2H₂O]. The $\delta^{34}\text{S}$ values of the gypsum crusts were between 0.5 and 6.5‰.

3.2 Avenul lui Adam (Adam Shaft)

Adam Shaft is located north of Băile Herculane on the west bank of the Cerna River at 135 m relative altitude (POVARĂ et al., 1972) (Fig. 1, #2). The passages are developed along a system of faults that intercept at depth the drainage of the Hercules thermal spring (DIACONU, 1987). Adam Shaft is famous for its bat colony and “tropical” biotope rendered from continuous hot (~47°C) steam emissions along these tectonic fractures (DECU et al., 1974). Considering these settings, it was not surprising to identify three, rather common cave phosphate minerals in this cavity: apatite-(CaOH), brushite [CaHPO₄·2H₂O)],

and apatite-(CaF) [$\text{Ca}_5(\text{PO}_4)_3\text{F}$]. The first two minerals develop ochre to dark brown crusts (few millimeters in thickness) in the lower part of the cave walls, fringing the guano deposits, as well as on wall ledges beneath freshly accumulated guano. All three minerals were primarily identified by means of XRD. Apatite-(CaF), which is intimately associated with apatite-(CaOH), was further confirmed by FT-IR analysis. The FT-IR spectrum of apatite-(CaF) confirms the absence of OH stretching and libration peaks, which are common in apatite-(CaOH) at about 3570 and 635 cm^{-1} , respectively (ROSS, 1974).



Figure 2: Earthy masses and efflorescences of various sulfates in Diana Cave.

Due to the very high temperatures and 100% relative humidity, we had about 20 minutes for sample collecting. The only gypsum crust we identified during this visit was in the lower part of the shaft, above one of the passages heavily affected by continuous hot steam circulation. The $\delta^{34}\text{S}$ value of the gypsum crust was 6.5‰.

3.3 Hercules Cave

Hercules Cave is developed east-west along a fault line, 5 m above Cerna's stream bed, at the northern limit of the Băile Herculane Spa (Fig. 1, #3). The Hercules thermal spring discharges through this cave which is now gated. Special permission is needed to enter the cave. The only access is through the Roman Hotel which dammed the spring in order to use the thermal water for medical treatments. The cave consists of a short (94.5 m), narrow, low-ceiling single meandering passage. The passage shows a typical phreatic morphology, which has been modified due to heavy alteration processes acting upon the limestone bedrock. Small-size cupolas and subspherical voids can be noticed

on the ceiling. From one cupola, we collected white-grayish submillimeter size crusts. The XRD analysis of bulk crust sample confirmed the presence of gypsum. The $\delta^{34}\text{S}$ value of the crust was 14.1‰.

3.4 Despicătură Cave

Despicătură Cave (105 m in length) is located about 100 m downstream from Hercules Cave (Fig. 1, #4). It has a Y-shape and hosts two thermal springs (Hercules II α near the junction of the two galleries and Hercules II β at the far end of the cave). Both springs were dammed and water was pumped out for medical use. Along all passages the cave walls are covered by thick (up to 7 cm) white granular gypsum crusts, which often are stained grayish-black. The isotopic investigation shows gypsum having $\delta^{34}\text{S}$ values ranging from 11.6 to 18.5‰, similar to the $\delta^{34}\text{S}$ value obtained for the sulfate in the Hercules II α spring (16.6‰) (SUMRALL, 2009).

3.5 Hercule Mining Gallery

Although not a cave, this mine was interesting to visit (Fig. 1, #5). Hot thermal water flows throughout the entire mine. Gypsum crusts are precipitated at different locations and the limestone bedrock is highly weathered. A light-blue moonmilk-like floor deposit was observed and sampled from a side niche along the main gallery. The XRD analysis of a bulk sample confirmed the presence of chalcantinite [$\text{Cu}^{2+}\text{SO}_4 \cdot 5\text{H}_2\text{O}$]. Because the gallery has been abandoned for quite some time, it is possible that this unusual mineral occurrence relates to the oxidation of copper materials left by the miners (cables or device parts) in a sulfate-rich, 100% relative humidity environment. Considering its location in a man-made cavity, chalcantinite might be regarded as a border mineral (i.e., it was formed by natural processes under cave-like conditions, but in the presence of an artificial material), rather than a typical cave mineral. The sulfur isotope values for chalcantinite and a gypsum crust were 3.3 and -3.0‰, respectively.

3.6 Diana Cave

Diana Cave is a short cavity (14 m in length) developed along the Diana Fault, at the contact between the upper Jurassic limestones and the marls of Iuta formation (NĂSTĂSEANU, 1980). It is located in the older part of Herculane Spa on the west side of the Cerna Valley (Fig. 1, #9). To capture and use the thermal spring therapeutically, the cave was enlarged by an artificial gallery that hides much of the original cave morphology behind precast concrete. Due to the aggressiveness of thermal sulfidic waters and steam, the concrete was weathered and the cave walls were exposed on limited surfaces allowing for sample collection.

The thermo-mineral spring (~51° C) and the highly steam condensate-related alteration environment in Diana Cave are responsible for the unusual mineral associations (seven species) precipitated at the water/bedrock interface.

The first report on the mineralogy of this cave is presented in POVARĂ et al. (1972), where gypsum, sulfur [S], and halotrichite [$\text{Fe}^{2+}\text{Al}_2(\text{SO}_4)_4 \cdot 22\text{H}_2\text{O}$] are briefly described. One year later, a detailed study undertaken by DIACONU and MEDEŞAN (1973) concluded that the main mineral phase of the efflorescences developed over the marl debris is pickeringite [$\text{MgAl}_2(\text{SO}_4)_4 \cdot 22\text{H}_2\text{O}$] and not halotrichite. The genesis of this mineral is related to the reaction between the acidic sulfate-rich solutions (pH ~ 4) and the clay minerals within the marls. DIACONU (1974) described acicular and prismatic crystals of anhydrite precipitated along with gypsum on cave wall crusts and on the ceiling. The NaCl- and MgCl_2 -enriched thermal waters and the thermal cave microclimate are considered responsible for the precipitation of anhydrite.

Our present work on earthy aggregates and efflorescences from Diana Cave (Fig. 2) reconfirmed the presence of sulfur, anhydrite, and pickeringite. In addition, we detected four other sulfates: apjonite [$\text{Mn}^{2+}\text{Al}_2(\text{SO}_4)_4 \cdot 22\text{H}_2\text{O}$], epsomite [$\text{MgSO}_4 \cdot 7\text{H}_2\text{O}$], halotrichite, and tamarugite [$\text{NaAl}(\text{SO}_4)_2 \cdot 6\text{H}_2\text{O}$]. The presence of the halotrichite-group minerals (apjonite, halotrichite, and pickeringite) was not surprising. A complete series does exist between the Fe^{2+} end-member (halotrichite), the Mg^{2+} analogue (pickeringite), and the Mn^{2+} end-member (apjonite). Under binocular microscope, the efflorescences and the mammillary/botryoidal crusts in which these three minerals were identified appear to be composed of fibrous and short acicular to prismatic crystals. Pickeringite is shiny white-yellowish to silver white and is closely associated (intergrown) with orange/yellowish-brown halotrichite. Apjonite forms fibrous microcrystals that have a silky luster and are tinted yellow to pale green. The XRD spectra of these minerals are practically indistinguishable; their identification relies on chemical microanalyses (electron microprobe). The genetic mechanism proposed by DIACONU AND MEDEŞAN (1973) for pickeringite also holds true for the other two mineral members of this series. Capillary action draws sulfate-rich solutions through the porous marls of the Iuta Formation. Upon reaching the surface, the water evaporates resulting in the deposition of halotrichite-group minerals.

Epsomite forms delicate fibrous (microcrystals elongated after [001]), patchy white efflorescences on the cave

walls. The epsomite is precipitated from Mg-rich sulfidic thermal waters. Tamarugite is a hydrated Na-Al sulfate first documented in Grotta dello Zolfo, Italy by ZAMBONINI (1907). Since then, it has been identified only in Alum Cave in Sicily and Ruatapu Cave in New Zealand (FORTI et al., 1996; RODGERS et al., 2000). At all these locations, however, the mineral is precipitated in a volcanic environment. Diana Cave seems to be the first truly karst setting in which the reaction between alkali-type sulfidic thermal waters and kaolinite and illite of Iuta marls resulted in the precipitation of tamarugite. It occurs as colorless to dull white, porous aggregates developed along with gypsum crusts, in the same areas where halotrichite-group minerals were identified.

The isotopic compositions of sulfate minerals from Diana Cave range from +18.0 to +19.5‰ for $\delta^{34}\text{S}$ in gypsum, tamarugite, halotrichite, and pickeringite. These values are typical for marine sulfates. We know, however, that the thermal water in Diana Cave is sulfidic, indicating that these sulfates were not simply dissolved and reprecipitated from marine sulfate within the stratigraphic section. No evaporite beds were ever documented from the Cerna Valley region (NĂSTĂSEANU, 1980). Since the sulfate minerals in Diana Cave have the same $\delta^{34}\text{S}$ values as the sulfate and sulfide ions in the thermal spring, they are by-products of the reaction of sulfuric acid with the limestone and marls occurring within the cave. Therefore, the cave belongs to the H_2SO_4 -acid speleogenetic type formed by the oxidation/hydrolysis of H_2S escaping from Diana spring water.

4. Conclusions

Our first results demonstrate that detailed investigations on the secondary minerals found in caves along Cerna Valley are useful for predicting the neof ormation of mineral assemblages and to infer the speleogenetic pathways. Two minerals, apjonite and tamarugite, are new additions to the cave minerals inventory. Tamarugite was previously documented from volcanic cavities; however, Diana Cave is the first limestone karst occurrence to host this mineral.

Our preliminary data indicate that the isotopic values decrease in a downstream trend. The Aburi and Adam caves (lower section, high elevation) display a narrow range of $\delta^{34}\text{S}$ values (from 0.5 to 6.5‰). The situation changes completely in caves that have openings near to the Cerna Valley (Hercules, Despicătura, and Diana) where enriched sulfur isotopic values were obtained (11.5 to 19.6‰). The range in values reflects the increase in completeness of the reduction of sulfate. Such values, however, suggest that the resulting cave sulfate isotopes depend not only on

the source of the sulfur, but also on the isotopic value of the reduced sulfide. These results suggest that the initial assumptions on the peculiar minerogenetic pathways for the caves along the Cerna Valley and the likely hypogene origin for some of these caves (or at least one hypogene phase in their evolution) are correct. More investigations are planned to provide additional information on the relevance and implications of thermal activity in hypogene speleogenesis and deposition of unique secondary cave mineral associations.

Acknowledgments

The Domogled-Valea Cernei National Park Administration generously allowed access to the field area and granted approval to remove specimens for analysis. The Romanian National University Research Council (grant ID_544 to Onac) contributed funds for this research.

References

- AUDRA, P. and F. HOBLÉA (2007) The first cave occurrence of jurbanite $[\text{Al}(\text{OH SO}_4)\cdot 5\text{H}_2\text{O}]$, associated with alunogen $[\text{Al}(\text{SO}_4)_3\cdot 17\text{H}_2\text{O}]$ and tschermigite $[\text{NH}_4\text{Al}(\text{SO}_4)_2\cdot 12\text{H}_2\text{O}]$: thermal-sulfidic Serpents Cave, France. *Journal of Cave and Karst Studies* **69** (2), 243–249.
- BURKE, E. (2008) Tidying up mineral names: an IMA-CNMNC scheme for suffixes, hyphens, and diacritical marks. *Mineralogical Record* **39**, 131–135.
- CODY, A.D. (1978) Ruatapu Cave, Orakei Korako. *New Zealand Speleological Bulletin* **6**, 184–187.
- CRISTESCU, I. (1978) *Tezaurul Cernei (Cerna's Treasure)*. Ed. Sport-Turism, București, 176 p.
- DECU, V.G., A. NEGREA, and Ș. NEGREA (1974) Une oasis biospéologique tropicale développée dans une région tempérée: "Peștera lui Adam" de Băile Herculane (Carpatés Méridionales, Roumanie), *Travaux de l'Institut de Spéologie "Emile Racovitza"* **13**, 81–103.
- DIACONU, G. (1974) Quelques considérations sur la présence de l'anhydrite dans la grotte "Pestera Diana" (Baile Herculane-Roumanie). *Travaux de l'Institut de Spéologie "Emile Racovitza"* **13**, 191–194.
- DIACONU, G., (1987) La géologie et la tectonique du périmètre d'influence la source thermo-minérale "Hercule", Băile Herculane. *Theoretical and Applied Karstology* **3**, 109–116.
- DIACONU, G. and A. MEDEȘAN (1973) Sur la présence du pickeringite dans la grotte de Diana (Băile Herculane, Roumanie). *Proceedings 6th International Congress of Speleology*, Olomouc, I, p. 231–239.
- DUBLYANSKY, Y.V. (1997) Hydrothermal cave minerals. in *Cave minerals of the world* (2nd ed.), Carol A. Hill and Paolo Forti (Eds.), National Speleological Society, Huntsville, AL, pp 252–255.
- DuCHENE, H.R. (1997) Lechuguilla Cave, New Mexico, U.S.A. in *Cave minerals of the world* (2nd ed.), Carol A. Hill and Paolo Forti (Eds.), National Speleological Society, Huntsville, AL, pp 343–350.
- FORTI, P., E. GALLI, and A. ROSSI (2006) Peculiar minerogenetic cave environments of Mexico: the Cuatro Ciénegas area. *Acta Carsologica* **35** (1), 79–98.
- FORTI, P., M. PANZICALA MANNA, and A. ROSSI (1996) The peculiar mineralogic site of the Alum Cave (Vulcano, Sicily). *Proceedings of the 7th International Symposium of Vulcanospeleology*, Canary Islands, pp 34–44.
- GRASSINEAU, N., D. MATTEY, and D. LOWRY (2001) Sulfur isotope analysis of sulfide and sulfate minerals by continuous flow-isotope ratio mass spectrometry. *Analytical Chemistry* **73**, 220–225.
- HILL, C.A. (1987) *Geology of Carlsbad Cavern and other caves in the Guadalupe Mountains, New Mexico and Texas*. New Mexico Bureau of Mines & Mineral Resources **117**, 150 pp.
- HILL, C.A. and P. FORTI (1997) *Cave minerals of the world* (2nd ed.), Huntsville, AL, National Speleological Society, 464 pp.
- MALTSEV, V. (1997) Cupp-Coutunn Cave, Turkmenistan. in *Cave minerals of the world* (2nd ed.), Carol A. Hill and Paolo Forti (Eds.), National Speleological Society, Huntsville, AL, pp 323–328.
- MALTSEV, V.A. and C.A. SELF (1992) Cupp-Coutunn Cave system, Turkmenia, Central Asia. *Proceedings of the University of Bristol Speleological Society* **19** (2), 117–149.

- NĂSTĂSEANU, S. (1980) Géologie des Monts Cerna. *Anuarul Institutului de Geologie și Geofizică*, LIV, 137 pp.
- ONAC, B.P. (2002) Caves formed within Upper Cretaceous skarns at Băița (Bihor county): mineral deposition and speleogenesis. *Canadian Mineralogist* **40** (6), 1551–1561.
- ONAC, B.P. (2004) Why study cave minerals? *Bolleti de la Societat d'Historia Natural de les Balears* **47**, 9–17.
- ONAC, B.P. (2005) Minerals. in *Encyclopedia of caves*, David Culver and William B. White (Eds.), Academic Press, New York, p. 371-378.
- ONAC, B.P., G. VENI, and W.B. WHITE (2001) Depositional environment for metatyuyamunite and related minerals from Caverns of Sonora, TX (USA). *European Journal of Mineralogy* **13**, 135–143.
- ONAC, B.P., J.W. HESS, and W.B. WHITE (2007) The relationship between the mineral composition of speleothems and mineralization of breccia pipes: evidence from Corkscrew Cave, Arizona, USA. *Canadian Mineralogist* **45**, 1177–1188.
- ONAC, B.P., J. KEARNS, P. DAMM, W.B. WHITE, and S. MATYASI (2000) The first reported occurrence of metatyuyamunite - $\text{Ca}(\text{UO}_2)_2(\text{VO}_4)_2 \cdot 3\text{-}5\text{H}_2\text{O}$ in Romania. *Romanian Journal of Mineralogy* **80** (1), 5–10.
- POVARĂ, I., G. DIACONU, and C. GORAN (1972) Observations préliminaires sur les grottes influencées par les eaux thermo-minérales de la zone Băile-Herculane. *Travaux de l'Institute de Spéologie "Emile Racovitza"* **11**, 355–365.
- RODGERS, K.A., K.A. HAMLIN, P.R.L. BROWNE, K.A. CAMPBELL, and R. MARTIN (2000) The steam condensate alteration mineralogy of Ruatapu cave, Orakei Korako geothermal field, Taupo Volcanic Zone, New Zealand. *Mineralogical Magazine* **64** (1), 125–142.
- ROSS, S.D. (1974) Phosphates and other oxy-anions of group V. in: *The infrared spectra of minerals*, V.C. Farmer (Ed.), Mineralogical Society, London, Monograph **4**, 383–422.
- SUMRALL, J. (2009) *Correlating dissolved sulfur species of springs to cave sulfate deposits using ^{34}S as a tracer in the Cerna Valley, Romania*. Unpubl. Master Thesis, University of South Florida, 90 pp.
- ZAMBONINI, F. (1907) Su alcuni minerali della Grotta dello Zolfo a Miseno. *Rend. Acad. Sci.*, ser. 3, **13-14**, 1–8.

CIOCLOVINA CAVE (ROMANIA): A UNIQUE MINERALOGICAL SETTING

BOGDAN P. ONAC^{1,2}, HERTA S. EFFENBERGER³, RADU C. BREBAN⁴, JOE B. KEARNS⁵

¹University of South Florida, Department of Geology, 4202 E. Fowler Ave., SCA 528, Tampa, FL 33620, USA,

²"Babeş-Bolyai" University Cluj/"Emil Racoviţă" Institute of Speleology, Clinicilor 5, 400006 Cluj, Romania

³Institute for Mineralogy and Crystallography, University of Vienna, Althanstrasse 14, Vienna, Austria

⁴SpeleoClub "Proteus", N. Bălcescu 13, Simeria, Romania

⁵The Pennsylvania State University, Materials Research Institute, University Park, PA 16802, USA

Abstract

The Cioclovina Cave, is located on the southwestern side of the Şureanu Mountains (Romania), is developed in Lower Cretaceous limestones. It is renowned for its enormous amount of phosphate-rich sediments that almost entirely fill some 450 meters of cave passage. By 1941, as much as 30,000 m³ of sediments had been mined for fertilizer resulting in good exposures of the sediment sequence (the thickness of sediments varies between 3 and 20 m) allowing for a detailed mineralogical work. The origin of phosphate-rich sediments is associated with large deposits of bat guano and thousands of cave bear remains, but other, allochthonous sources are now investigated.

Successive cave flooding events have resulted in the accumulation of large quantities of clay and sand that are inter-bedded with bat guano horizons or have completely buried the organic sediment. These events and the resulting sediment sequences have produced conditions that allow for a great diversity of minerals to form in Cioclovina Cave. In some parts of the cave, the weight of the overburden sediments was significant that the underlying material has been heavily compacted so that textures and structures of the original sediments cannot longer be recognized. Owing to microbial processes, the temperature inside the buried guano increased until spontaneous ignition led to its combustion, converting the sediment to a dark brown color. It is within this particular type of sediment that we detected the high-temperature minerals, berlinite and ellestadite-(OH).

The uniqueness of the mineral assemblage found in the Cioclovina Cave is known since 1932 when Schadler described the new mineral *ardealite*, Ca₂(HPO₄)(SO₄)·4H₂O, and mentioned this cave as the type locality. Extensive studies were carried out during the last decade propelling the Cioclovina Cave among the top ten mineralogical caves in the world. The common cave minerals calcite, aragonite, gypsum, apatite-(CaOH), brushite, monetite, crandallite, and taranakite are accompanied by a number of rare mineral species such as burbankite, churchite-(Y), foggite, paratacamite, sampleite, and tinsleyite, completing an imposing list that totals to 26 minerals.

MINERAL DIVERSITY IN CAVES FROM MALLORCA ISLAND, SPAIN

BOGDAN P. ONAC^{1,2}, JOAN J. FORNÓS³, ÀNGEL GINÉS^{3,4}, JOAQUIN GINÉS^{3,4},
GLEN HUNT¹, ANTONI MERINO⁴

¹University of South Florida, Department of Geology, 4202 E. Fowler Ave., SCA 528, Tampa, FL 33620, USA

²"Babeş-Bolyai" University Cluj/"Emil Racoviţă" Institute of Speleology, Clinicilor 5, 400006 Cluj, Romania

³Departament de Ciències de la Terra, Universitat de les Illes Balears, Spain,

⁴Federació Balear d'Espeleologia, Palma de Mallorca, Spain

Abstract

The island of Mallorca is located in the western Mediterranean Sea. The island is the largest and the most central in the Balearic Archipelago. Eighteen caves were investigated. Ten of these caves were formed in the Upper Miocene calcarenites. Eight of the other investigated caves are developed in Mesozoic limestones. From a speleogenetic point of view, the Majorcan caves and shafts are divided into four categories: vadose shafts, vadose, phreatic, and littoral caves. In the present study, the majority of speleothems investigated were collected from caves assigned to the littoral category. All types of speleothems formed by dripping, flowing, and seeping water (stalagmites, stalactites, shields, flowstones, crusts, helictites, eccentrics, etc.) are well represented throughout most of the cavities on the Mallorca Island.

Seventeen minerals, divided into four chemical groups, were identified and described using X-ray diffraction, infrared, thermal, and scanning electron microscope analyses. Calcite is the only mineral found in every sampled cave. Aragonite, gypsum, and apatite-(CaOH) occur in speleothems from four different caves. In addition, a few other carbonates (ankerite, dolomite, hydromagnesite, and monohydrocalcite), phosphates (ardealite, brushite, collinsite, and taranakite), and silicates (illite, montmorillonite, muscovite, and quartz) were identified in crusts, minute crystals, and earthy masses.

This first extended mineralogical work reveals the existence of two outstanding caves: Cova de sa Guitarreta and Cova de ses Rates Pinyades. Both these caves display the most diverse mineralogy on the island. This is due to presence of massive deposits of bat guano (fresh and fossil) that cover bedrock, clay sediments, and speleothems to the extent that they barely protruded through it.

Based on the mineral inventory derived from our investigations, the following mechanisms are ultimately responsible for the precipitation of minerals in caves from Mallorca Island: (i) precipitation from percolating water (ankerite, aragonite, calcite, hydromagnesite, monohydrocalcite, dolomite, and gypsum), (ii) precipitation related to the freshwater/sea-water mixing zone (calcite, aragonite, and gypsum), (iii) reaction between the phosphate-rich leachates derived from bat guano and the underlying bedrock and clay sediments (apatite-(CaOH), ardealite, brushite, collinsite, taranakite, and gypsum), and (iv) phase transitions (aragonite to calcite inversion).

DESCRIBING THE MICROSTRUCTURE OF A SODA STRAW

VICTOR J. POLYAK¹ and PAULA P. PROVENCIO²

¹*Earth & Planetary Sciences, University of New Mexico, Albuquerque, New Mexico 87131*

²*Sandia National Laboratories, Albuquerque, New Mexico 87185-1421*

A soda straw fragment (a common speleothem subtype), from Hell Below Cave in the Guadalupe Mountains, was sectioned and studied using optical microscopy and high resolution transmission electron microscopy (HRTEM). The “Western” description of the soda straw microstructure, based on optical microscopy cross-polarized methods, is described as crystalline calcite fabric dominated by split crystal growth and twinning. HRTEM shows a relatively complex crystalline mechanism that is interpreted to be responsible for the split crystal microstructure. Nano-scale line defects, such as off-sets and twinning, in the crystal lattice enable the production of large-scale split crystal (radial fibrous) growth. We applied the “ontogeny of cave minerals” concept to the soda straw to examine its usefulness to our understanding of soda straw growth. Comparable terminology is available here in the “West” that can be applied to such studies in speleology. However, the ontogeny of cave minerals approach differs in that it provides a systematic way of describing the components of speleothems in relation to their origin and environment. We foresee modifications of the ontogeny of cave minerals method that can be easily applied from the microstructural physical examination of speleothems.

1. Introduction

A soda straw (Fig. 1), subtype of a stalactite, is a common and simple tubular dripstone speleothem (HILL and FORTI, 1997), which is sometimes described as a monocrystalline speleothem. It is also a component of most typical stalactites. We have examined a segment of soda straw from Hell Below Cave, Guadalupe Mountains using optical and electron microscopy. While the soda straw is monomineralic and a simple speleothem subtype, its microstructure is complex and not easily described. This microstructure is typical of Guadalupe Mountain speleothemic calcite. We used a “Western” method to describe the microstructure of the soda straw. By “Western”, we mean descriptive methods and terminology used in the United States to describe crystal fabrics. We also used the “ontogeny of cave minerals” method as presented by SELF and HILL (2003) to describe this Hell Below Cave soda straw.

2. “Western” Petrographic Description

The soda straw fragment from Hell Below Cave is smooth and “glassy” on its exterior, and coarsely crystalline in its interior. Thin section observations under crossed polarization through an optical microscope show multiple complex “composite” crystals made up of “subcrystals.” All of these calcite crystals and subcrystals show sweeping extinction, indicating some level of disorder at the nano-

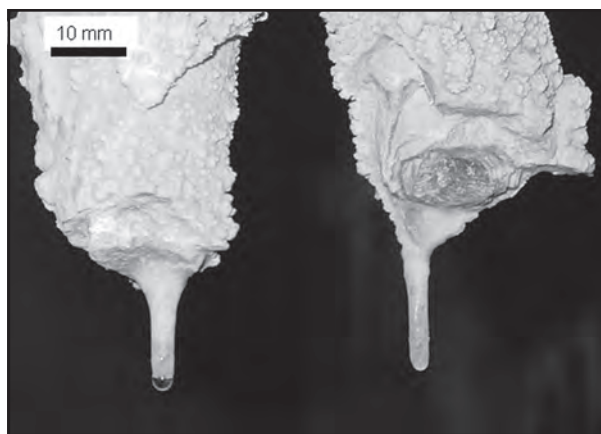

Figure 1: Less than 100 year-old soda straws growing from broken stalactites. The Hell Below Cave soda straw was collected already-broken, and is not one of the straws in this figure.

scale that is not clearly resolvable using optical microscopy. The fragment of soda straw from Hell Below Cave is composed entirely of calcite having structural disorder.

2.1. Crystals, split crystal growth, and subcrystals

The term “split-crystal” growth is not used often. One of the first uses of this term was by LEHMANN (1911, in GRIGOR’EV, 1961). Split crystal growth results in “lineage structure” (BUERGER, 1934) or is described as branchlike

extensions of a single crystal that when coalesced form imperfect intercrystalline boundaries. These extensions are essentially synonymous with crystallites (FRISIA et al., 2000), subgrains (HIRTH AND LOTHE, 1982), subcrystals (KOSTECKA, 1995) and subindividuals (GRIGOREV, 1961). The resulting crystals are commonly referred to as “composite” or “offset” crystals (VANDERS AND KERR, 1967).

Sweeping extinction of calcite within single crystals observed with optically polarized microscopy is indicative of split crystal growth (Fig. 2). This type of extinction is common in speleothemic calcite in the Guadalupe Mountains (POLYAK, 1992). It is the most important characteristic of calcite in the Hell Below soda straw. Figure 3 shows primary “leaf-shaped” subcrystals within the interior of the Hell Below soda straw, each having secondary split growth within them. The larger “primary” subcrystals appear to be crudely shaped rhombohedral terminations. The terminations have curved and rough crystal faces that at best approximate the fundamental or true rhomb crystal faces. These imperfect faces are referred to as “vicinal faces” (MIERS 1903; BUCKLEY 1951; MERRIAM-WEBSTER 1970).

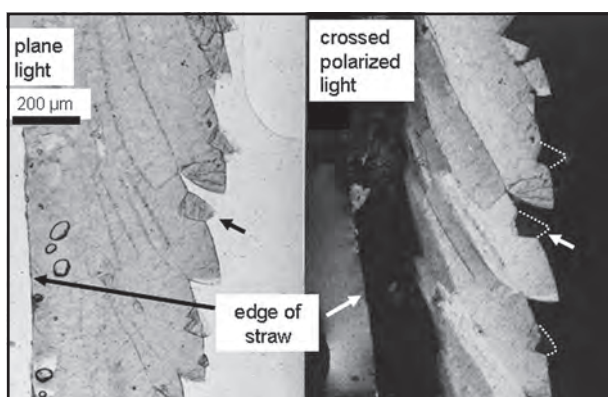

Figure 2: Thin section micrograph of the wall of a soda straw from Hell Below Cave. The image on the left shows large subcrystals splitting from a larger composite crystal. The arrow points to a growth hillock on one of these subcrystals. The image on the right is viewed through crossed polarizers and shows different shades of gray representing varying degrees of orientation caused by crystal splitting. White arrow points to growth hillocks that are optically extinct under crossed polarizers.

2.1.1. Microstructural mechanism suggested for split crystal growth at the atomic scale: Ultimately, it is the organization of the atomic structure (calcite has a trigonal structure) that governs the shape of individual crystals, crystal aggregates, and speleothems. We examined the soda straw



Figure 3: SEM image of the interior surface of the Hell Below Cave soda straw. Note the leaf-shaped subcrystals and their flat, imperfect vicinal faces. These leaf-shaped subcrystals are crudely formed rhombohedral terminations. Also note the pyramid-shaped, twin-generated growth hillocks.

from Hell Below Cave using high resolution transmission electron microscopy (HRTEM) in an attempt to identify atomic scale disorders that might have caused some of the unusual individual shapes. Nano-scale observations show characteristics of individual crystals that help explain the origin of subcrystals through crystal splitting.

Figure 4A shows areas of contrast change in an HRTEM image. These areas represent extremely subtle changes in the arrangement of atoms in the calcite lattice. While subtle, we propose that these changes are propagated and result in distinct orderly-disorder at the larger scale. Figure 4B is a high resolution image of the same area as Figure 4A. Lattice fringes within each region of contrast are continuous (illustrating that a region of contrast is a single crystal orientation). At the edge of the contrast intensity of region A, the lattice fringes are terminated at a twin boundary resulting in a change in crystal orientation. One set of lattice fringes continues into region B and a second

contrast intensity results. Although one set of lattice fringes continues through the twin boundary, the cross fringes are different between regions A and B showing that the crystal orientation changes slightly. This twin offset spans a short distance and is again terminated at another twin boundary resulting in a third orientation, region C. The same set of lattice fringes continues into the third region, but the cross fringes are slightly different resulting in a third orientation. This third orientation spans a distance and then this mechanism repeats and the first orientation (regions A) is again obtained. These differences at the nanometer scale may propagate into split crystal growth at the millimeter scale.

2.2 Twinning

Within the interior of the Hell Below Cave soda straw, small growth hillocks were observed on the unusually shaped primary subcrystals (Fig. 5). These hillocks are optically extinct under crossed polarizers at 60° relative to the extinction of the subcrystal they are attached to, showing that the hillocks are twins of the subcrystal (Fig. 5). These hillocks are significantly smaller than the host subcrystal. They are not uncommon and show up in other speleothems or travertine deposits as small “crystals” included within larger crystals (Fig. 6).

2.3 Complexity of individual crystals

It is difficult to define individual “composite” crystals in this

soda straw. By definition they form imperfect crystal boundaries. It is likely that during initiation of soda straw growth, numerous small crystals nucleated along the edge of water droplets on a host surface (probably bedrock). These crystals were constricted to the water surface around the first drops of water. The drip water chemistry and microenvironment most likely favored fast growth (saturation index $\gg 0$, abundant Mg), resulting in frequent but constricted crystal-lattice disorder. Consequently split crystal morphology has a fairly periodic disorder. The first composite crystals could have possibly coalesced to form larger composite crystals thereby restricting the number of individual crystals present in the soda straw. It is potentially possible that coalescence (not recrystallization) progressed such that the soda straw can be said to be comprised of only a few composite crystals, or perhaps even one large composite crystal. In

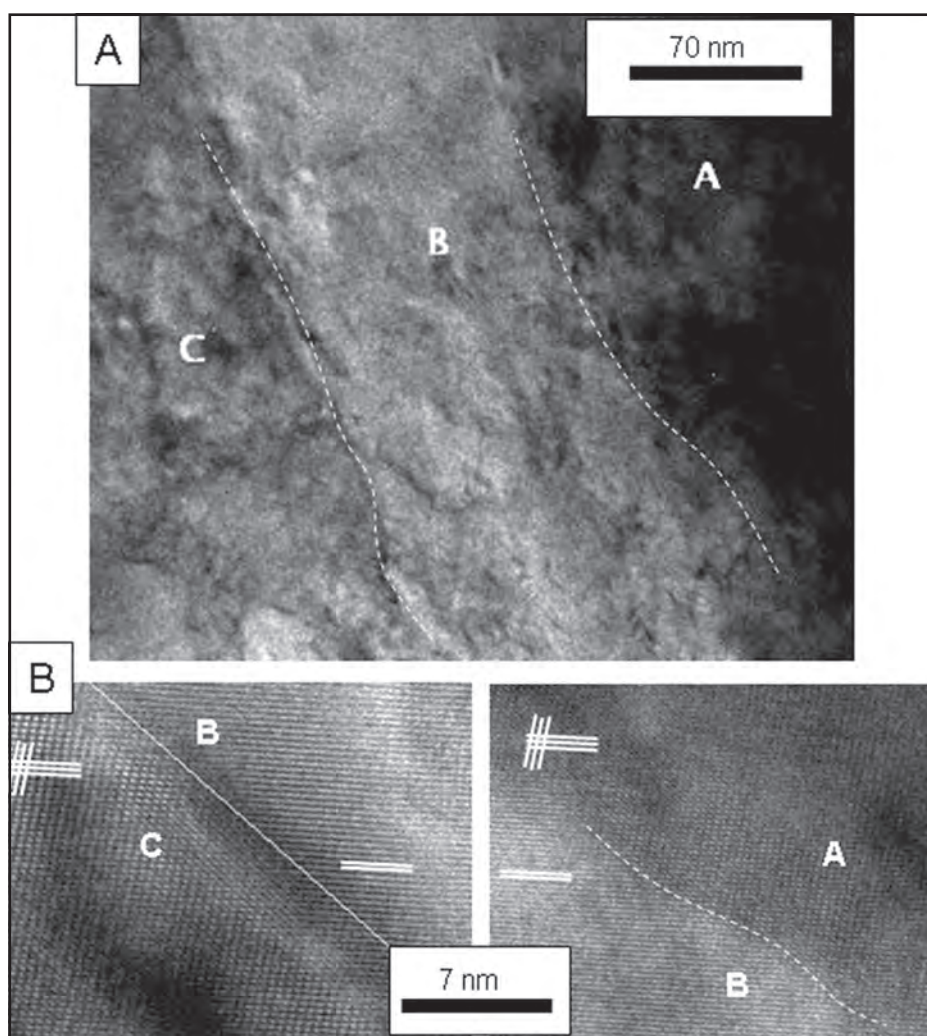

Figure 4: HRTEM images of a region of the soda straw calcite. Differences in contrast represent subtle nano-scale imperfections of the atomic ordering. Top image shows three regions of phase contrast defined by dotted lines. The images on the bottom show that regions A and C show lattice fringes in two directions, while region B shows lattice fringes in one direction, yet all three regions show lattice continuity in one direction indicating they are all part of the same crystal. These subtle differences are interpolated to propagate as crystal defects such as split crystal growth.

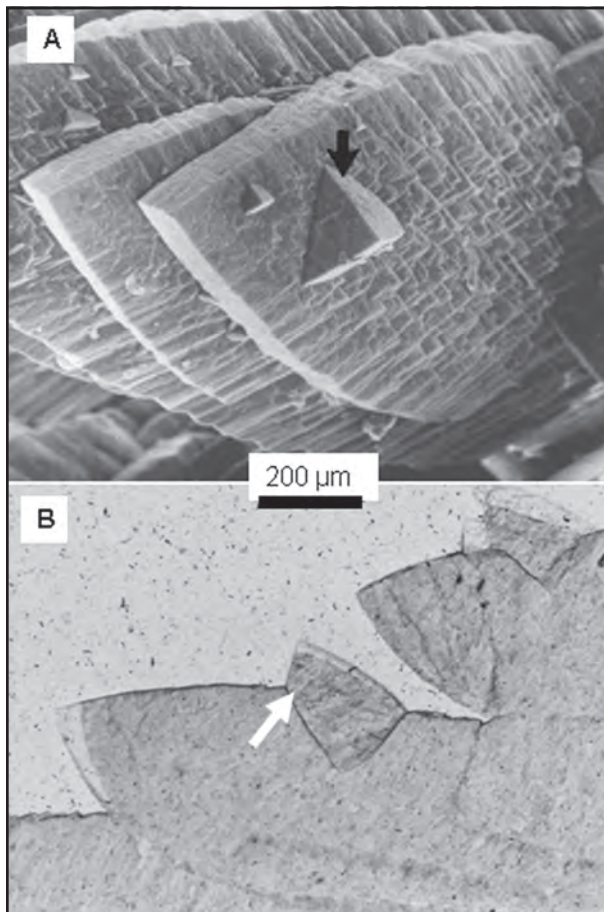

Figure 5: A closer look at leaf-shaped subcrystals. (A) A SEM image showing growth hillocks on surface of leaf-shaped subcrystals. (B) Thin section micrograph showing section through subcrystal and hillock. Each leaf-shaped subcrystal is a distorted rhomb (faces of the rhomb are rough and curved). Twinning expresses itself as growth hillocks (arrows in both A and B).

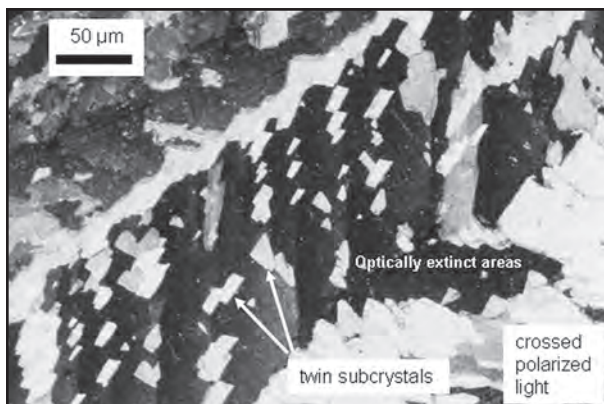

Figure 6: Thin section micrograph viewed through crossed polarizers showing multiple growth hillocks in fibrous surface-travertine calcite from Sitting Bull Falls.

either case, the calcite crystals making up the soda straw are complex.

3. Application of the Ontogeny of Cave Minerals to the Hell Below Soda Straw

SELF and HILL (2003) published an introduction to the “ontogeny of cave minerals,” which is the study of individual crystals and their aggregates developed by Russia’s mining industry and adopted by speleologists. A frustrating aspect of carbonate and speleothem petrography is the loose terminology used to describe crystal fabrics. Because most early studies used optical microscopes, the terminology usually reflects two-dimensional views of crystals and crystal fabrics. Three-dimensional studies using scanning electron microscopes have seemingly done little to address problems with terminology related to crystal fabrics in speleothems. The ontogeny of cave minerals is an approach that may help with the description and understanding of crystal and speleothem growth in caves. We offer a brief examination of the Hell Below soda straw, using the ontogeny of cave minerals approach. Our examination includes attempts to compare the ontogeny with what we would consider typical “Western” petrography. In the following discussion refer to the terminology of minerals ontogeny defined by SELF and HILL (2003).

3.1 A soda straw according to Ontogeny of Cave Minerals

A simple soda straw consisting only of calcite, but of numerous crystals is an “aggregate of individuals” according to SELF and HILL (2003). The soda straw in our case is a physical mineral body that results from “synchronous crystallization,” only in the sense that the soda straw consists of only the individuals from which growth of the soda straw started with the addition of few individuals over a relatively short period of time. This may be very difficult or impossible to determine, depending on how it is interpreted. We suggest that new individuals likely nucleate during growth of a soda straw, making the straw an aggregate of individuals. These individuals can be quite complex.

3.1.1. First Level: Individuals (crystals) in the soda straw:

According to ontogeny of cave minerals, an “individual” is a single crystal. The individual can be simple (first-order) or complex (second-order). Second-order individuals are crystals with lattice defects that result in the formation of subindividuals. Subindividuals are essentially subcrystals. Crystal defects cause distortion of the lattice such that the crystals split or become curved. Western speleologists interested in adopting minerals ontogeny might prefer to use terminology such as “first-order” crystals and “second-order” (composite) crystals.” Our soda straw individuals are composed of second-order crystal individuals. This is obvious from standard thin-section petrography, where

sweeping extinction within the crystals is observed under crossed-polarization when the microscope stage is rotated. Figure 2 shows part of a second-order individual. In our soda straw, we see remarkable examples of second-order crystals such as split crystals and twin crystals.

The most striking subdivision of second-order individuals is crystal splitting as exhibited in Figure 3, an SEM image of the interior surface of the soda straw. Subindividuals formed by crystal splitting are the leaf-shaped, distorted rhombohedral terminations in the interior of the soda straw. The entire SEM image shows numerous subindividuals of only part of a larger second-order individual. There seem to be multiple examples of subindividuals: those nano- to micron-scaled subindividuals that form sweeping extinction, those decimicron-scaled subindividuals that form split “subcrystals” with oddly shaped rhombohedral terminations as seen in Figure 3, and the subindividuals that make up the straw wall from which other subindividuals split. All are a result of crystal splitting.

In these calcite soda straws, growth hillocks (Fig. 5) form on the subindividual rhombohedral terminations. The hillocks represent twinning as indicated by thin section petrography (POLYAK, 1992).

Regarding the “first level” of the ontogeny of cave minerals, we conclude that our soda straw is an aggregate made up of complex composite (second-order) individuals. These composite individuals are composed of split crystal-twin individuals. We could also conclude that the soda straw is made up of second-order individuals having at least three types of subindividuals. A “Western” twist to this might identify the petrography as a soda straw made up of composite crystals having at least three types of split subcrystals, and one type of twin subcrystals.

3.1.2. *Second Level: Aggregates in the soda straw:* As mentioned previously, the soda straw is likely composed of several individuals. That defines the soda straw as an aggregate. Other individuals likely nucleated during growth of the soda straw. The soda straw in our case is an aggregate of individuals that seems to fit the radial-fibrous aggregate category. All individuals of our soda straw are split-crystal individuals. Growth of individuals is restricted only by competitive growth, and the boundaries of the soda straw wall and water droplet. The term radial-fibrous aggregate (SELF and HILL, 2003) is a bit confusing. It seems that it would be more appropriate to call the aggregate a “split-growth aggregate.” Split-growth crystal aggregate seems even more appropriate.

3.1.3. *Third and Fourth Levels; Koras and Esembles:* The first two levels are not unfamiliar to petrographers. Most mineralogy books include a brief outline and description of crystal habit and crystalline aggregates (HURLBUT, 1971). Many of the descriptors of habit and aggregates are identical or similar to the categories within the first two levels of *minerals ontogeny*. The real difference is the organization of the first two levels principally for cave mineralogy. The third level, koras, and the fourth level, ensembles, however, introduces a potentially exciting concept new to Western speleologists, but application of them goes beyond this study.

4. Concluding Remarks

Our description of the microstructure of a soda straw from Hell Below Cave using the ‘Western’ and *mineral ontogeny* terms has led us to conclude with a discussion of the following question. What purpose is addressed that would make one of these or a mix of the two descriptors actually useful? Ontogeny of cave minerals has helped us to expand on this question and on a related problem. For example, paleoclimate work using speleothems is taking place in every corner of the planet. Yet a simple fundamental question is often asked that weighs on the merit of such studies. How can we tell if the calcite/aragonite of paleoclimate samples is altered or recrystallized. It may not be easy to tell, but characterizing the structure of speleothems for each geographical region would obviously be very useful. The concept of kora becomes important, because it can be applied to this problem, for it considers time and place in combination with genesis of structure. In other words, we might expect to see split growth aggregates in pristine unaltered speleothems from the Guadalupe Mountains. European caves, for instance, might show greatly different crystal structures, habits, and fabrics in their pristine speleothems. While the soda straw seems like a simple speleothem subtype, our examination shows that it can be quite complex. Harnessing that complexity is a challenge. Perhaps blending and modifications of different approaches such as the two approaches used in this paper (‘Western’ and ‘ontogeny of cave minerals’) will help us to systematically meet this challenge. Ontogeny of cave minerals seems to be a useful way to approach this challenge, but we foresee needed modifications to ontogeny of cave minerals that would make it less cumbersome to use.

References

- BUCKLEY, H.E. (1951) *Crystal growth*, John Wiley and Sons, New York, 571 pp.
- BUERGER, M.J. (1934) The lineage structure of crystals.

Zeitschrift für Kristallographie, **89**, 195–220

- FRISIA, S., A. BORSATO, I.J. FAIRCHILD, and F. MCDERMOTT (2000) Calcite fabrics, growth mechanisms, and environments of formation in speleothems from the Italian Alps and southwestern Ireland. *Journal of Sedimentary Research* **70**: 1183–1196.
- GRIGOREV, D.P. (1965) *Ontogeny of minerals*. Daniel Davey & Co., Inc., Israel program for scientific translations, translation of Ontogeniya Mineralov, 1961, 251 pp.
- HILL, C.A. and P. FORTI (1997) *Cave Minerals of the World*. National Speleological Society, Huntsville, Alabama, 238 pp.
- HIRTH, J.P. and J. LOTHE (1982) *Theory of dislocations*. John Wiley & Sons, New York, 857 p.
- HURLBUT, C.S. (1971) *Dana's Manual of Mineralogy*. John Wiley & Sons, New York, 579 pp.
- KOSTECKA, A. (1995) A model of orientation of subcrystals in saddle dolomite. *Journal of Sedimentary Research A: Sedimentary petrology and processes* **A65**, 2 pp.
- MERRIAM-WEBSTER, A. (1970) *Webster's seventh new collegiate dictionary*. G. & C. Merriam Company, Springfield, Massachusetts, 1223 pp.
- MIERS, H.A. (1903) *An enquiry into the variation of angles observed in crystal; especially of Potassium-alum and Ammonium-alum*. Philadelphia Transactions A **202**, 459–523.
- POLYAK, V.J. (1992) The mineralogy, petrography and diagenesis of carbonate speleothems from caves in the Guadalupe Mountains, New Mexico. Unpublished M.S. Thesis, Texas Tech University, Lubbock, 165 pp.
- SELF, C.A. and C.A. HILL (2003) How speleothems growth: An introduction to the ontogeny of cave minerals. *Journal of Cave and Karst Studies* **65** (2), 130–151.
- VANDERS, I. and P.F. KERR (1967) *Mineral Recognition*. John Wiley & Sons, Inc., New York, 316 pp.

WHICH FEATURES OF THE CAVE ENVIRONMENT CONTROL THE GROWTH OF SPELEOTHEMS?

CHARLES SELF

University of Bristol Speleological Society, UK, self@globalnet.co.uk

Speleothems are secondary mineral bodies that are chemogenically deposited in caves. The chemistry of the supply solution controls the mineral species being deposited, but it does not determine what type of speleothem is formed (stalactite or cave pearl, for example). The degree of supersaturation of the supply solution only affects the *structure* of crystal individuals. A low degree of supersaturation allows the slow growth of large spar crystals, whereas a high degree of supersaturation causes rapid nucleation of many small and complex individuals, often forming split crystals or dendrites.

About 300 mineral species have now been identified in caves, but only three can be considered common – calcite, aragonite and gypsum. However these few minerals display a bewildering variety of speleothem forms. To understand why, it is necessary to study the physical aspects of the cave environment and how this affects the growth of individual crystals. This branch of genetic mineralogy is known as ontogeny and has mainly been studied in Russia. Ontogeny is the study of single crystals (mineral individuals), how these crystals combine as aggregates, and their growth as physical bodies.

Most speleothems are mineral aggregates, formed from several (sometimes many) similar crystals of the same mineral species. The component crystal individuals do not simply grow together, they interact and compete for growth space and/or the supply of new material. This interaction between individuals causes a distinctive pattern of crystal boundaries to develop in the aggregate. This pattern is called *texture*. Texture describes the geometric aspects of construction of an aggregate and depends mainly on the characteristic (Curie) symmetry of the medium from which crystallization occurred. For example, the capillary film environment has conical symmetry because of the geometry of evaporation physics, so branching aggregates such as coralloid speleothems and frostwork are found here.

The many different speleothem types are classified not only by their internal construction, but also according to their morphology. Morphology describes the typical physical shape of a speleothem. Stalagmites, flowstone and draperies are the same type of aggregate and often form together in the same gravitational water environment. Because they have a different geometry of supply of the feeding solution, these texturally similar speleothems have distinctly different morphologies.

1. Introduction

A *cave mineral* is a secondary mineral deposit, growing in a cave, that is described by its chemistry and mineral species. About 300 cave minerals have now been identified, but only three mineral species (calcite, aragonite and gypsum) can be considered common. Primary mineral bodies (e.g. the bedrock, clastic sediments within the cave) are important sources of material from which (secondary) cave minerals form (Hill and Forti, 1997). Calcite is therefore a cave mineral when growing as a stalactite, but not when it is a mineral vein in the cave wall.

A *speleothem* is a secondary mineral deposit, growing in a cave, that is described as a physical body. These bodies are described by specific *speleothem terms* (such as stalagmite,

pool spar and cave raft) which refer to both the physical shape of the mineral deposit and its internal construction. The mineral species is not important when defining speleothem terms, so an epsomite cave flower is constructed in the same way as a gypsum cave flower. The chemistry of the solution supplying a speleothem controls the mineral species, but it does not control the speleothem type.

Similar mineral bodies to speleothems can be found in mines and other enclosed spaces. When examined closely, a stalactite growing beneath a railway bridge may show the same morphology and internal construction as a stalactite from a cave. In such circumstances it is quite acceptable to use speleothem terms (such as stalactite) for these mineral deposits. But it is not acceptable to call such deposits

“speleothems”, as this term is specific to the mineralogical landscape of caves.

Throughout the world, the three common cave minerals (calcite, aragonite and gypsum) grow in a variety of speleothem forms. To understand why, it is necessary to study the physical aspects of the cave environment and how this affects the growth of individual crystals. This branch of genetic mineralogy is known as ontogeny and has mainly been studied in Russia (Grigor’ev, 1961). Ontogeny is the study of single crystals (mineral individuals), how these crystals combine as aggregates, and their growth as physical bodies.

The obvious environmental factor to consider first is the degree of supersaturation of the supply solution. Very high supersaturation leads to the rapid nucleation of many small crystals. Tufaceous speleothems and moonmilk can be produced this way (with or without the presence of bacteria). High levels of supersaturation often create growth defects, which may accumulate and result in crystal splitting. This is common in cave minerals, particularly carbonate minerals such as calcite and aragonite, where high levels of supersaturation are achieved by a combination of evaporation and carbon dioxide degassing. Aragonite in caves usually occurs as split crystals. At the other extreme, in hydrothermal systems the level of supersaturation can be very low and a small number of large and perfectly formed crystals develop, such as the famous gypsum crystals in natural voids of the Naica mine in Mexico.

Supersaturation affects the *structure* of crystals, but it does not change which type of speleothem is growing. Normal calcite flowstone is made of unsplit crystals, whereas the type that the Americans call “coconut meat” is made of split crystals. Changes in the level of supersaturation of

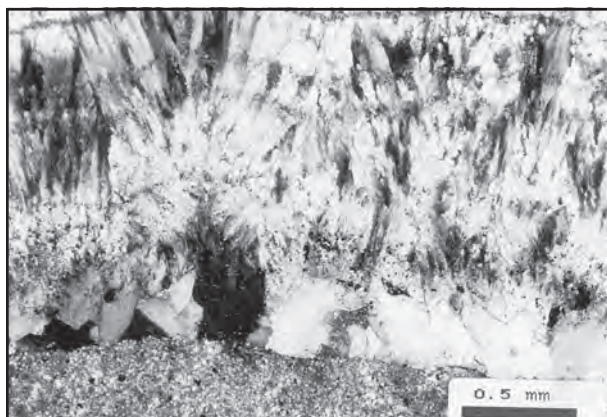

Figure 1: As the supply solution becomes more saturated, the spar crystals at the base of this flowstone change to split coconut-meat crystals. Photo V. Polyak.

the supply solution can produce layers of split and unsplit crystals (Fig. 1), but the speleothem type is still flowstone.

Speleothems are generally not built from single crystals; gypsum (selenite) needles are the only common exception to this rule. Most speleothems are built from several (sometimes many) similar crystals of the same mineral species and are thus *mineral aggregates*. The component crystals (*mineral individuals*) of an aggregate do not simply grow together, they interact and compete for growth space and/or the supply of new material. Competition between crystal individuals often leads to a reduction in the number of individuals constituting the aggregate, a situation called *selection*.

The most important selection process is *geometric selection*: the mineral individual whose greatest growth vector during competitive growth is best aligned for mass-transfer with the environment is the one that will continue its growth at the expense of neighbouring individuals of other orientations (Self and Maltsev, 1999; Self and Hill, 2003). Aggregates are therefore much more than similar individuals of the same mineral species, growing together simultaneously. Interaction between individuals directly affects and limits the growth of each crystal. This interaction causes a distinctive pattern of crystal boundaries to develop in the aggregate. This pattern is called *texture* and different aggregate types are distinguished by having different textures.

It is worth repeating here that *speleothem type* is not the same as *aggregate type*. A speleothem is described by both morphology and texture. Thus, flowstone and stalagmites are the same type of aggregate (based on texture) but are different types of speleothem. For a more detailed description of how speleothems are constructed, the reader is referred to Self and Hill (2003).

The physical description of a speleothem has two components: external shape (morphology) and internal construction. Morphology depends on how new material is supplied to the speleothem, whereas internal construction can be related to the environmental conditions of the crystallization space as a whole. The internal construction of a speleothem is therefore more informative.

2. The Curie Universal Symmetry Principle

There is no effect without cause (Curie, 1894). The symmetry aspects of this relationship can be expressed as: the characteristic symmetry (or the dissymmetry) of an object or medium must be found in the causes that

generated that object or medium. This is known as the Curie Universal Symmetry Principle (Stepanov, 1998), and is a simplification of the 1894 original observation.

The *characteristic symmetry* of a phenomenon may be regarded as an ideal symmetry for that object or medium. A similar concept has been used in regular mineralogy to divide all mineral species into seven different crystal systems. It does not matter if a crystal is deformed or broken, it belongs to a particular crystal system because this is a function of the internal structure of the mineral species itself (e.g., calcite belongs to the trigonal system). The characteristic symmetry of a medium does not depend on the physical shape of the space in which it is enclosed, but is innate to the medium itself. The symmetry groups for phenomena identified by Curie include three static groups (spherical, cylindrical and conical) and a further four which involve motion (e.g., a magnetic field has the symmetry of a rotating cylinder). Only the three static groups are needed to describe the texture of mineral aggregates in caves and the mediums from which they form.

Spherical symmetry is indicated when the texture of an aggregate displays complete disorder, since all directions from any point are equivalent. Similarly, a medium has spherical characteristic symmetry when it is isotropic. An example is phreatic deposition from a supersaturated solution. Whatever the shape of the crystallization cavity, crystal embryos (crystallites) nucleate on all available surfaces and are randomly oriented during the first stage of growth.

The distinctive feature of *cylindrical* symmetry is growth along one axis. This axis may change direction as the aggregate develops, but growth in other directions is severely limited. This means that each crystal has neighbouring crystals sub-parallel to it, whatever its location and orientation. The classic example is a helictite, where several crystals surround and grow parallel to the central feeding channel. (For the growth mechanism of helictites, see Self and Hill 2003).

Conical symmetry has a single axis, which is the preferred direction of aggregate growth, but some growth in other directions is allowed. Each crystal has neighbouring crystals diverging from it, whatever its orientation and location. The capillary film environment has conical symmetry because of the geometry of evaporation physics. Solvent molecules are most easily lost in the direction of the open cave, but some molecules leaving at an oblique angle to the substrate will also be lost, particularly where the substrate is convex.

This allows branching aggregates such as corallites and crystallinities to grow in this environment.

Dissymmetry can be thought of as the set of symmetry elements which are missing. (Note: dissymmetry is not the same as *asymmetry*, which is a general lack of symmetry.) Unidirectional forces, such as gravitation and geometric selection, are dissymmetries which commonly affect mineral growth. If we return to the case of phreatic deposition from a supersaturated solution, which has spherical symmetry, the randomly oriented crystallites all grow at the same rate until they start competing for growth space. Geometric selection then reduces the number of individuals forming the aggregate (Fig. 2) to leave a new growth front of druse crystals oriented perpendicular to the substrate (a parallel-columnar aggregate). The dissymmetry of gravitational selection therefore causes a reduction in the symmetry of the aggregate.

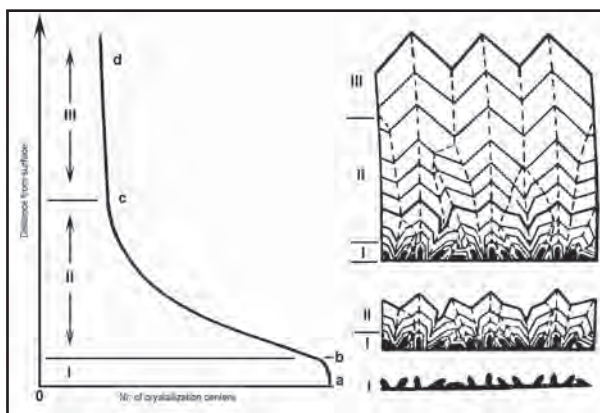

Figure 2: Growth of a parallel-columnar aggregate (from Grigor'ev, 1961). The dissymmetry of geometric selection changes spherical to cylindrical symmetry.

At the local level, a druse has cylindrical symmetry. However, druse crystals cover the walls, floor and ceiling of the crystallization space, and so point in every direction. Also the druse grows to the same thickness on all surfaces. These are surviving features of the original spherical symmetry. From this we can see that the texture of a druse has two levels of symmetry: cylindrical when examined at the local level, spherical when the whole aggregate is studied. This example shows how texture responds to environmental factors that operate at different scales, with genetic information conserved on all levels.

3. Geometry of Supply

Texture describes the internal organization of an aggregate, but it does not control its external shape. Variations in morphology are particularly well seen in caves, where the

same type of aggregate can produce speleothems of radically different appearance. The reason for this lies in variations in the geometry of the supply scheme (supply of solute and/or loss of solvent). It is important to note that this is not the same as the symmetry of supply to a crystallization space (which controls texture). These are different concepts and operate at different organizational levels in the cave environment. There are four basic supply geometries.

Bulk supply is any supply scheme that is isotropic. The essential point is that the medium itself does not impose any dissymmetry on the texture of the crystalline products. Bulk supply may be completely subaqueous (as in a phreatic or cave-pool setting), laminar or turbulent gravity flow streams (as for flowstones), bulk solutions moving slowly through a porous medium, or the bulk freezing of a melt. This supply scheme does not allow individuality in an aggregate, so the only differences that can be seen are in the size and habit of the component individuals.

Area supply is a two-dimensional feeding scheme whereby solutions spread out slowly over a crystallization surface from capillary thin films. The evaporation of capillary films is very sensitive to local air flows and to irregularities in the substrate, so considerable variation in morphology is seen among the corallites which grow in this environment. Area supply also applies to crystallization along phase boundaries, such as the growth of rafts at the air/water interface of cave pools.

Linear supply is where a solution gathers into linear streams or issues from fracture openings. Mostly, this supply scheme modifies aggregates that form by bulk or by axial supply. It always results in the appearance of dissymmetry, usually with the elimination of the rotation axis. On steep or overhanging cave walls, the bulk supply of gravitational water gathers into linear streams and flowstone converts into draperies. These two speleothem types have essentially the same texture, but their morphologies are different. Shields grow from fracture openings by linear supply, but when solution overflows from the edge of the shield, the supply scheme reverts to bulk supply and flowstone overgrows the underside of the shield. Crystalline shields can also develop from helictites when the axial supply of the capillary channel becomes blocked and solution escapes through a structural line of weakness.

Axial supply is a one-dimensional feeding scheme typified by solutions moving through the middle of a speleothem, or feeding one single growth spot. These are "point-source" solutions where growth is aligned along a single axis. The

most obvious point source in caves is water dripping from the roof and landing on the floor, from which grow regular stalactites and stalagmites. Axial supply causes them to grow out into the cave void, but it is the bulk supply of solutions running down their sides which thickens them. Stalactites and stalagmites are thus essentially the same type of aggregate as flowstone, but with a different supply scheme. If the linear supply to a drapery ends at a drip point, a stalactite will grow from this place. Another type of axial supply is solution seeping along the central canal of a helictite, which causes it to grow outwards from the substrate.

In the subaerial environment of caves, there may be differences in the supply scheme to different parts of a single speleothem. For example, in a cave with a strong airflow, the bulk supply of solution on one side of a stalactite may evaporate and become a capillary thin film. Corallites may start to grow on this side, while the rest of the stalactite continues to develop normally (Fig. 3). Large stalagmites may find that drip water does not flow evenly down their sides, but gathers into rivulets giving locally enhanced



Figure 3: The dissymmetry of a strong seasonal wind causes evaporation on one side of this stalactite and the growth of corallites directly into this wind. Photo C. Self.

growth rates. These minor variations in the supply scheme are responsible for the great variations in morphology that we see in some speleothems.

4. Multiaggregates

Multiaggregates are essentially the same as other types of aggregate, except that they are constructed in a more complicated manner. They may be polymineral or polytextural, but the different crystals are growing simultaneously and in the same environment. An example of a polymineral multiaggregate is a multicorallite, which has at its base a calcite corallite, from which grows an aragonite needle tipped with a soluble mineral such as hydromagnesite. They grow by evaporation in the same way as usual corallites, so they have area supply and conical symmetry. However the supply solution contains both calcium carbonate and magnesium carbonate. As the capillary film evaporates and deposits material, the magnesium to calcium ratio of the remaining liquid increases from the base towards the tip. By changing the chemistry of the supply solution, the multicorallite changes the mineralogy of the crystals being deposited.

A stalactite has three textures and is therefore a polytextural multiaggregate. In its outer part, it is the same type of aggregate as flowstone, draperies and stalagmites (Moore, 1962). This explains why these aggregates all grow together in the gravitational water environment. However, a regular stalactite also has a monocrystalline tube running through its centre. When examined closely, the drip point of this tube has a crown of skeleton crystals (Fig. 4). It is important to understand that stalactites are not soda straws overgrown by a later surface crust - the three textures form together and simultaneously. Maltsev (1999) has shown that the central tube appears as a consequence of the growth mechanism, not as a cause. Stalactites are not normally supplied with solutions down the central tube. If a stalactite is broken, new growth (and a new central tube) begins at the drip point which may have no physical connection to the old central tube. Stalactites grow entirely as a result of a solution oversaturated with respect to calcium carbonate running down the outside and dripping from the tip.

The growth of skeleton crystals at the tip of the stalactite is due to mechanical agitation of the solution as the drip disconnects. Carbonate solutions are very sensitive to local changes in pressure, caused by such vibrations, and respond by releasing CO₂ and depositing calcite. Mechanical degassing typically produces skeleton crystals (Shafranovskiy, 1961). The reason for this lies in the overall reaction for calcium bicarbonate dissociation, which may be

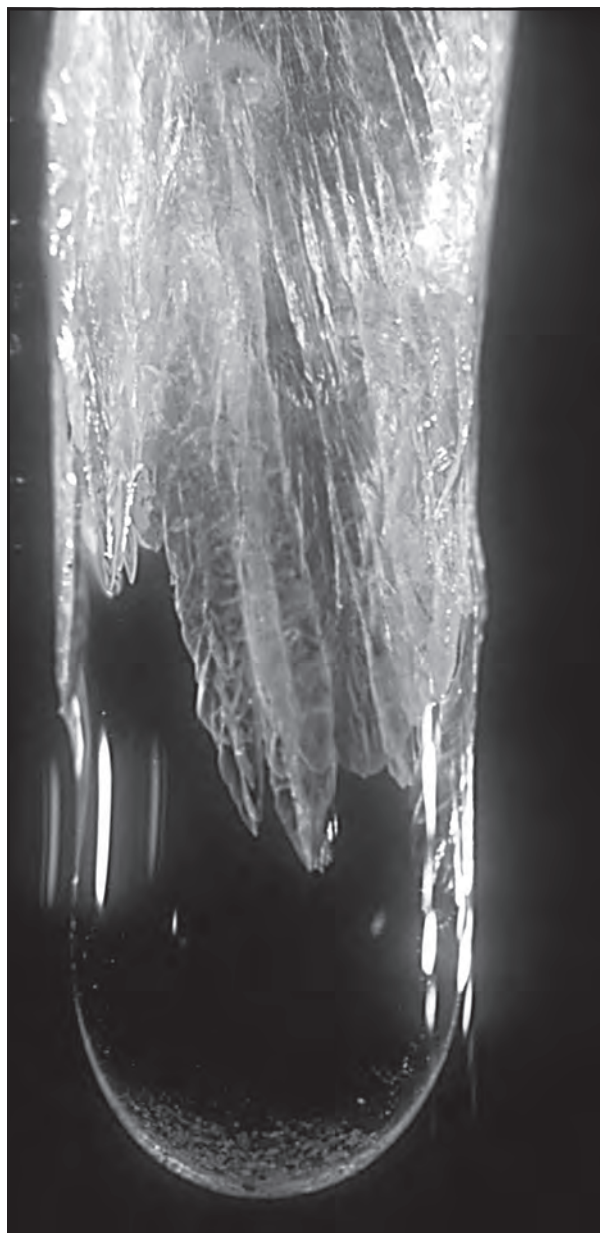

Figure 4: The drip point of a stalactite, with a crown of skeleton crystals. Photo V. Maltsev

summarised as:



The pressure waves caused by drip disconnection do not change the balance of this reversible reaction, as the overall effects of the positive and negative parts of the wave cancel each other out. However the speed of the forward and backward reactions are very different. Calcium bicarbonate dissociates rapidly but reforms only slowly. The empirical proof of this is that stalactites do grow, whereas if the reaction speeds were in reverse there would be dissolution at the drip point. The underlying cause is probably an

intermediate reaction involving carbon dioxide in solution in water. As anyone who has accidentally dropped a can of carbonated drink will know, after an initial disturbance that last about one second, the tab cannot be pulled for several hours without explosive decompression of the contents. To return to the drip on our stalactite, the solution itself has spherical symmetry but rapid degassing at the phase boundary causes a local dissymmetry at the surface of the drip. Skeleton crystals form rapidly, in a ring in the plane of the phase boundary.

The second texture, the monocrystalline tube, has its greatest growth vector oriented vertically and is a result of recrystallization. It cannot have formed by the growing together of skeleton crystals because too much energy is tied up in all their crystal edges and faces. Skeleton crystals are thermodynamically unstable and readily recrystallize. The trigger for this recrystallization is the shock wave that travels vertically up the solution column, inside the central tube, when each drip is released. These first two textures are extremely local in extent and only develop in the special environment of the drip point.

The third texture, which comprises the bulk of the stalactite, is the overgrowth around the central tube. This forms from the bulk supply of solution running down the side of the stalactite, which itself has no dissymmetries. Many small crystals grow with random orientation until competition and geometric selection leads to sub-parallel crystal growth (as in Figure 2). However, because the substrate is sharply curved, this becomes a variation of parallel-columnar texture known as a spherulitic aggregate (Stepanov, 1998). The result is a radiating fan of crystals around the central tube.

5. Conclusions

The solutions that deposit speleothems have little influence on what type of speleothem will be formed. Water chemistry determines the mineral species while supersaturation determines the size and structure of crystal individuals. But it is geometric factors in the cave environment that decide which speleothem will be formed. Characteristic symmetry controls texture and therefore what type of aggregate can grow, while the geometry of the supply scheme determines what it will look like.

References

- Curie, P., 1894, Sur la symetrie dans les phenomenes physique, symetrie d'un champ electrique et d'un champ magnitique: *Journal de Physics*, ser. 3, vol 3, pp 395–415.
- Grigor'ev, D.P., 1961, Ontogeny of minerals: Lvov, Izdatel'stvo L'vovskogo Univ. In Russian. English translation 1965, Israel Program for Scientific Translations, 250 pp.
- Hill, C.A., and P. Forti, 1997, *Cave minerals of the world* (2nd ed.): National Speleological Society, Huntsville, Alabama, 463 pp.
- Maltsev, V.A., 1999 (for 1998), Stalactites with “internal” and “external” feeding: *Proceedings of the University of Bristol Speleological Society*, vol 21, no. 2, pp149–158.
- Moore, G.W., 1962, The growth of stalactites: *National Speleological Society Bulletin*, vol 24, no. 2, pp 95–106.
- Self, C.A., and C.A. Hill, 2003, How speleothems grow: An introduction to the ontogeny of cave minerals: *Journal of Cave and Karst Studies*, vol 65, no. 2, pp 130–151.
- Self, C.A., and V.A. Maltsev, 1999, Translators' note: *Cave Geology*, vol 2, no. 4, pp 193–195.
- Shafranovskiy, I.I., 1961, Crystals of minerals: curved-faced, skeletal and granular forms: “Gosgeoltekhizdrt”, Moscow, 230 pp. In Russian.
- Stepanov, V.I., 1998 (for 1997), Notes on mineral growth from the archive of V. I. Stepanov (1924-1988): *Proceedings of the University of Bristol Speleological Society*, vol 21, no. 1, pp 25–42.

SPELEOSOL: A SUBTERRANEAN SOIL

MICHAEL N. SPILDE¹, ARA KOOSER¹, PENELOPE J. BOSTON^{2,3}, DIANA E. NORTHUP⁴

¹ Department of Earth and Planetary Sciences, MSC03-2050, University of New Mexico, Albuquerque, New Mexico, USA

² New Mexico Institute of Mining and Technology, Socorro, New Mexico, USA

³ National Cave and Karst Research Institute, Carlsbad, New Mexico, USA

⁴ Department of Biology, MSC03-2020, University of New Mexico, Albuquerque, New Mexico, USA

Mud and soil deposits occur in many caves. Frequently, they are transported into caves by flooding or infilling. However, in several caves around the world, soil-like material has been found that appears to be an autochthonous product of pedogenic or soil-forming processes that take place in these caves. The pedogenic alteration of bedrock results in mass loss, mass transfer, and mineral transformation via chemical and microbial weathering. The material has been variously known as “corrosion residue” and “cave ferromanganese deposits,” but because of the soil-like character and the processes forming this material, we propose to establish the term *speleosol* to refer to soil-like material formed in the cave. The term should not include allochthonous sediments washed into the cave or autochthonous sediments such as sand and silt remaining from primary speleogenesis.

1. Introduction

Secondary mineral deposits in caves may include a wide array of unusual minerals, many of which may be mediated by microbial communities. Caves often provide an ideal environment for chemolithoautotrophic growth of microbial communities, and evidence of their existence is often observed in the minerals that are produced. Examples include ferromanganese deposits (FMD) that are discussed here, moonmilk, and pool fingers. FMD are interesting because they involve both alteration of the cave walls and deposition of secondary minerals. These deposits are accumulations of low density, soil-like material that line the walls, floors and ceilings of some caves (Fig. 1). Thus far, FMD have been observed in caves in New Mexico, Arizona, and South Dakota (USA), and in Turkmenistan (MALTSEV, 1997). However, the most prodigious deposits occur in Spider and Lechuguilla Caves in Carlsbad Caverns National Park, New Mexico. The deposits are highly enriched in secondary aluminum hydroxide minerals, iron



Figure 1: Sampling chocolate-brown FMD on a wall in Lechuguilla Cave. Photo by Val Hildreth-Werker.

oxyhydroxide and manganese oxide minerals, along with clays, quartz, carbonates, phosphates and sulfates.

Cave FMD are similar in many ways to laterite soils (oxisols). In these leached soils, sedimentary 2:1 clays (e.g. smectite, illite) are converted to 1:1 clays (e.g. kaolinite) (SPOSITO, 1989). Soluble elements such as K, Ca, Na, Mg, Si are leached from the system and other elements such as Al, Fe and Mn are enriched in sesquioxides. Insoluble trace elements (Ti, Zr, Nb) are enriched (BUOL and ESWARAN, 2000). Both chemical and microbial processes influence the formation of surface soils. Similarly, chemical weathering occurs in caves from the condensation of weak carbonic acid on cave walls that may contribute to the breakdown of bedrock carbonate. Likewise, microbial breakdown of bedrock plays a significant role (BOSTON et al., 2001; NORTHUP et al., 2003, SPILDE et al., 2005), as microorganisms present on the cave wall release organic acids. Both the chemical and microbial dissolution of carbonate contributes to a “weathering” process, making Fe and Mn available to microbial communities for energy utilization. Thus, the process of formation of FMD is one of pedogenesis or a soil-forming process. Because of the soil-like nature of this material, we will refer to it as “speleosol.” In this paper we will determine the degree of weathering and collapse that results from dissolution of bedrock at the cave-air interface and leaching from the underlying bedrock, and the subsequent amount of enrichment in the residual surface layer.

2. Chemistry and Mineralogy of Speleosol

Like most soils, speleosols consist of chemically and

mineralogically distinct layers. In Lechuguilla and Spider Caves, three layers make up the speleosol: (1) a colorful outer layer highly enriched in Fe- and Mn-oxides that ranges in thickness from less than a cm to a number of cms; (2) a leached layer of soft, altered bedrock that may extend many cms into the cave wall; and (3) the underlying, unaltered bedrock that may be either dolostone or limestone (Fig. 2). The outer layer consists mainly of oxide minerals and clays in a spectrum of color from light pink, to blood red, brick red, yellow, orange, ocher, brown, chocolate brown, gunmetal grey, or jet black. Lithiophorite $[(Al, Li)Mn^{4+}O(OH)_2]$, nordstrandite and gibbsite [both $Al(OH)_3$], goethite, kaolinite, and illite have been identified in the oxide layer by X-ray diffraction (XRD), scanning electron microscopy (SEM), and X-ray microanalysis (SPILDE et al., 2005).

Transmission electron microscopy has revealed that much of the abundant Fe- and Mn-oxides are poorly crystalline, consisting of nanometer- and micrometer-scale domains of coherent lattice. Todorokite $[(Mn^{2+}, Ca, Na, Mg, K)Mn_3^{4+}O_7 \cdot H_2O]$ and birnessite $[(Ca, Na)_{0.5}(Mn^{4+}, Mn^{3+})_2O_4 \cdot 1.5H_2O]$ have been identified by synchrotron micro-XRD (BOSTON et al., 2004). Iron and manganese in the oxide layer are hundreds to thousands of times enriched relative to the underlying bedrock; Fe_2O_3 in the oxide layer may be as high as 78 wt% compared to less than 1 wt% in the bedrock and MnO_2 as much as 57 wt% compared to 200 ppm or less in the bedrock. Not only are these elements strongly enriched, the Mn/Fe ratio increases by an order of magnitude from around 0.07 in the bedrock and in the lighter colored oxide layers to 0.8 in the dark oxide layers,

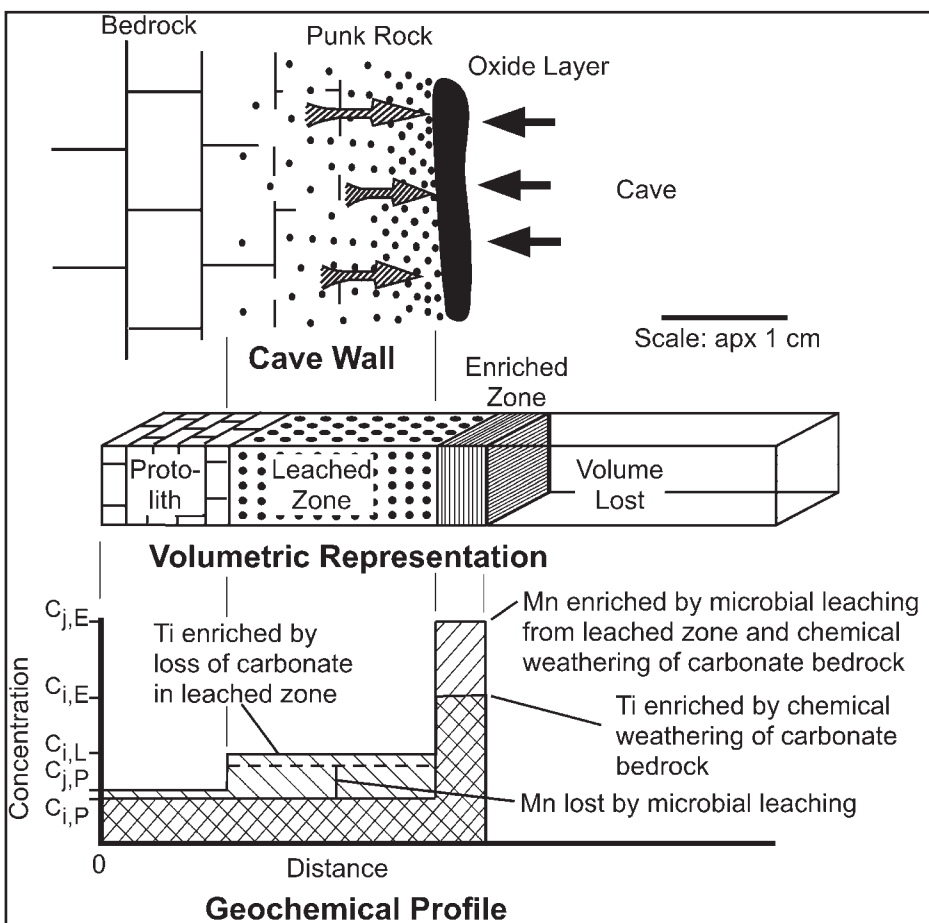

Figure 2: Schematic diagram of cave speleosol. Top: illustration of an idealized cross section through the cave wall, from bedrock (left) through punk rock and oxide layer and into the cave passage on the right side, with an approximate scale shown. Gray arrows represent microbial leaching of the punk rock and black arrows represent chemical weathering by condensation corrosion. Middle: diagrammatic representation of the original volume of bedrock, which after leaching and chemical weathering, consists of remaining bedrock, a leached zone (punk rock), an enriched zone (oxide layer), and the volume lost to weathering and leaching. Bottom: Hypothetical geochemical profile through the speleosol showing enrichment of immobile element due to carbonate dissolution at surface and in leached zone and enrichment of mobile elements in the enriched zone.

suggesting an enrichment of manganese over iron in the dark material (SPILDE et al., 2005).

Under the oxide layer is a soft, leached layer of bedrock of variable thickness called “punk rock” by HILL (1987), which occurs in shades of pink, yellow or white. This layer consists of partially dissolved carbonate bedrock, and in the SEM, severely etched calcite or dolomite crystals are abundant (SPILDE et al., 2005). Where the punk rock occurs in dolomite, intermixed calcite is often selectively removed and the dolomite recrystallized into euhedral crystals. Minor clays (illite and kaolinite) and trace gibbsite and quartz are the only notable minerals in this layer besides calcite and/or dolomite. The carbonate bedrock, below the punk rock layer, contains major calcite or dolomite, depending on where the cave passage is located in the Capitan Reef complex. Accessory

minerals include small amounts of clays (dickite, illite, kaolinite, or smectite), some of which are allogenic; other detrital minerals include quartz, feldspar, apatite, monazite, hematite, and rutile.

3. Origin of Cave Speleosol

The oxide-rich layer was originally called “corrosion residue” and was believed to be the insoluble residue from either attack of corrosive air on the carbonate bedrock (QUEEN, 1994) or insoluble material remaining from sulfuric acid speleogenesis (DAVIS, 2000). In the process of condensation corrosion, warm moist air rises in Rayleigh-Bernard convection cells and water is condensed on the ceiling and upper cave walls, presumably because these areas are slightly cooler due to the geothermal gradient (SARBU and LASCU, 1997). The condensed water absorbs CO_2 from the air to form carbonic acid that corrodes the carbonate bedrock. Thus, the speleosol in this model represents the insoluble residue left after the dissolution of the bedrock by the weak acid. However, the Fe and Mn in the oxide layer are many times more enriched than can be explained by acidic corrosion of carbonate, either as result of condensation corrosion or as a residue of speleogenesis. Simple dissolution of Guadalupe carbonate bedrock by acids ultimately leaves a silica-rich residue with slightly enriched Fe_2O_3 and barely detectable MnO (SPILDE et al., 2005). Thus, processes more complex than simple dissolution are necessary to explain this enrichment.

BOSTON et al. (2001) and NORTHUP et al. (2003) demonstrated that speleosols host an active microbial community that includes iron and manganese oxidizers, acid-producing, and nitrogen-cycle bacteria. SPILDE et al. (2005) showed that the deposits were highly enriched in Mn- and Fe-oxides and presented a model in which Fe and Mn enrichment is the result of microbial activity. In this model, microbes release organic acids that break down the carbonate bedrock in the punk rock layer, releasing Fe(II) and Mn(II) present in trace amounts in the carbonate minerals. Iron- and manganese-oxidizing microbes utilize the reduced Fe and Mn, oxidizing the elements as an energy source. The microbes may transport the released Fe and Mn from the punk rock zone with chelating ligands or as networks of exopolysaccharides. The oxidized respiration products build up in the oxide layer as Fe- and Mn-(hydr)oxides. This microbial model does not preclude the additional influence of the previous corrosion condensation model and both processes may be active simultaneously.

4. Methods: Mass Balance Analysis

A quantitative mass balance approach makes it possible to

use chemical elements in rocks and soils as geochemical tracers of specific hydrochemical processes during weathering or supergene enrichment (BRIMHALL et al., 1985). Such an approach must take into account chemical, physical, volumetric, and mechanical properties of the weathered product to compare with the unaltered protolith or bedrock. This technique quantitatively calculates mass loss and changes in volume (strain) due to dissolution of mobile elements. Residual enrichment of immobile elements (such as Ti, Al, Zr or Nb; indexed here as i) occurs by the removal of more soluble or locally mobile species (indexed as j ; Eqn. 1). In the absence of lateral flux, the mass of an immobile element (i) contained in the original protolith volume (p) before weathering is retained in the rock after weathering (w) by chemical or microbial processes, and is given as the product of volume, density, and concentration (BRIMHALL and DIETRICH, 1987).

The 3-dimensional volume may be simplified to consider only the thickness of the individual zones in the profile, since the flow path of water is essentially into or out of the cave wall surface. Thus, B can be used to represent the columnar length of the representative volume of protolith and weathered equivalent, substituting B_p and B_w for the respective V terms. Since the original length of bedrock is unknown, we need to introduce a term for one-dimensional strain $\epsilon_{i,w}$, which we can define as the change in length divided by the original length, $\epsilon_{i,w} = (B_{i,w} - B_{i,p})/B_{i,p}$. In this manner, the strain can be stated in terms of the measurable quantity $B_{i,w} = B_{i,p}(\epsilon_{i,w} + 1)$. Thus we can define a non-dimensional equation describing residual enrichment, in which strain is the only unknown (BRIMHALL and DIETRICH, 1987).

$$\frac{C_{i,w}}{C_{i,p}} = \frac{B_{i,p}}{B_{i,w}} \frac{\rho_p}{\rho_w} = \frac{1}{(\epsilon_{i,w} + 1)} \frac{\rho_p}{\rho_w} \quad (1)$$

The first term in the equation is the enrichment factor, calculated on the concentration of Ti as an immobile element. The second term yields the accumulated strain and the third term is the density ratio between protolith and weathered product, which in our case is the carbonate bedrock and FMD, respectively.

Bulk chemical analysis was performed on 21 colored FMD oxides, 13 punk rock, and 10 bedrock samples (including 4 surface bedrock samples) from Lechuguilla and Spider Caves. Of these, half represented dolostone protolith and half limestone. Cave samples were collected under permit from Carlsbad Caverns National Park, and surface bedrock was collected from road cuts on public land outside of

the National Park. Major and minor elements were analyzed by means of X-ray fluorescence (XRF), with a detection limit of 0.01 wt% in most cases; trace elements, including Ti, were analyzed by Inductively Coupled Plasma-Optical Emission Spectroscopy (ICP-OES), providing a detection limit of < 1 ppm for Ti. Bulk density of bedrock and particle density of the oxide layer and punk rock was determined by a standard soil science technique (ROWELL, 1994). The FMD bulk density was calculated from particle density and the weight lost in drying the samples prior to bulk chemical analysis. This assumes that the water in the sample maintains porosity and that the volume of pore space is equal to the volume of water lost, a reasonable assumption in an environment of saturated humidity. Since the dark oxide layer samples experience as much as 70% loss of weight in drying, this gives an upper limit on density.

5. Results

The data for Ti and Al are plotted in Figure 3 showing density ratio vs. enrichment factor. The high level of enrichment for both Ti and Al indicate that a large amount of carbonate has been removed by dissolution. A simple residual weathering path would follow the $\epsilon = 0$ line. Higher degrees of residual enrichment will plot along the strain line representing the amount of collapse. For example, a number of the samples from the dolostone protolith plot along the $\epsilon = -0.9$ line, indicating that 90% of the soluble material has been removed. Thus, 10 mm of initial bedrock would collapse into to a 1 mm oxide layer. The punk rock samples cluster between a density ratio of 1 and 2 (Fig. 3 inset) and mostly plot between $\epsilon = 0$ and $\epsilon = -0.75$, indicating that some samples have experienced little collapse while others

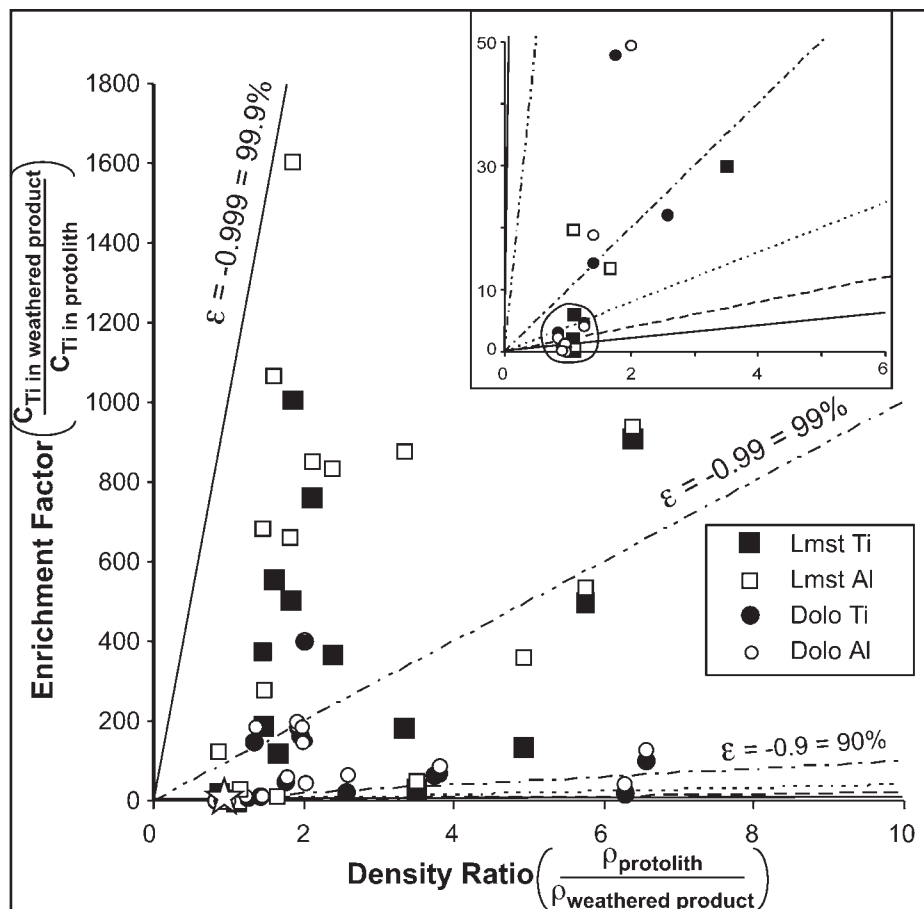

Figure 3: Enrichment factors for the insoluble element Ti are plotted against density ratio for oxide layer and punk rock samples. Samples from both limestone (squares) and dolostone protoliths (circles) are shown; the unaltered protolith plots at 1 (star) for both limestone and dolostone. The data for Al (open symbols) is also plotted. Various degrees of strain (ϵ) are plotted as lines originating from the origin. Positive strain represents dilation and negative strain, collapse. Inset: Expanded origin corner showing clustering of punk rock samples (circled).

have undergone as much as 75% collapse from removal of soluble carbonates. This is a fairly small range of values compared to the limestone protolith, where most samples have experienced between 99 and 99.9% collapse. The fact that the Al is more enriched than the Ti in many of the limestone samples indicates that Al has been mobilized and enriched in the oxide layer and cannot be regarded as an immobile element.

Porosity is defined as the ratio of void volume to total volume and is calculated in soil from the ratio of the bulk sample density (r_w) to the grain density (r_g) by $n = 1 - r_w / r_g$ (BRIMHALL and DIETRICH, 1987). By plotting porosity as $1 / (1 - n)$, as porosity n increases, $1 / (1 - n)$ increases as well, and the enrichment factor varies linearly with density ratio. Figure 4 illustrates porosity data from the limestone protolith samples. In this figure, two distinct trends are observed: one with a very high degree

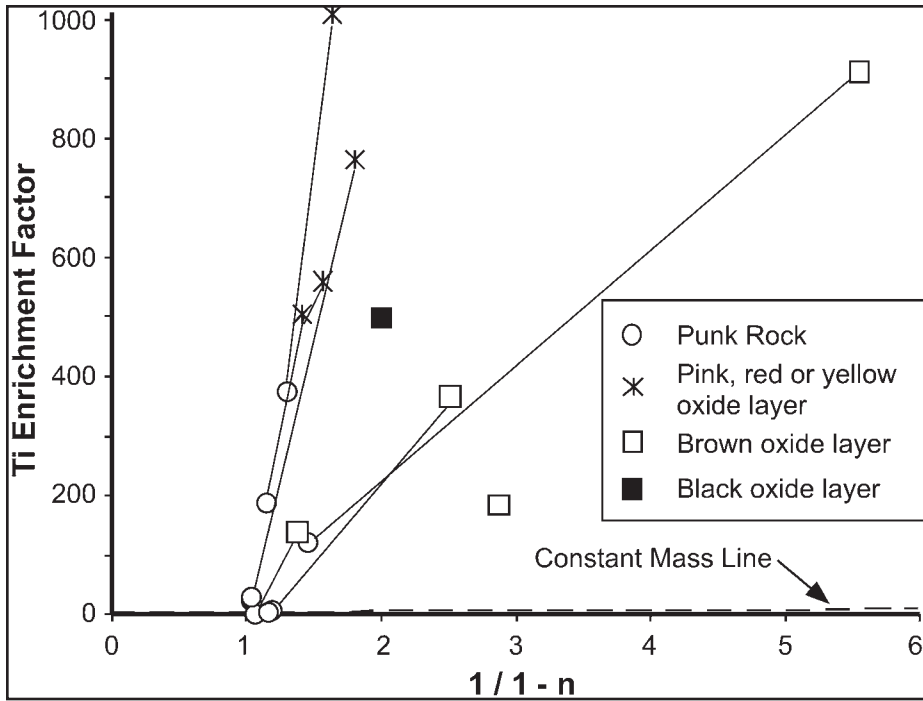

Figure 4: Punk rock and oxide layer samples from limestone protolith are plotted in terms of porosity (n). For those where paired samples were collected, tie-lines connect the oxide layer samples with the punk rock directly underneath. The constant mass line is noted ($\Sigma = 0$).

of porosity representing the darker-colored oxide samples and the other trend of high enrichment with only a small change in porosity, representing the lighter-colored oxide layer samples (pink, yellow, and reds). Similar trends are found in the dolostone protolith samples. The black, manganese-rich oxide layers tend to be anomalous compared to the other dark brown samples in that they exhibit low porosity change and low Ti enrichment. This suggests that the range of colors, from light (pink, reds, etc) to the darkest samples is not a continuum and different processes are acting to produce the dark samples and high manganese samples.

With the degree of Ti enrichment due to carbonate dissolution now established, we have a way to determine the

enrichment of mobile elements such as Fe and Mn. If a soluble element is removed from the system, the degree of enrichment of Ti can be used to establish the degree of enrichment or depletion of other elements. Elements within a sample should have an enrichment factor similar to Ti, in the absence of mobilization or deposition of that element. If enrichment factors are appreciably different, then we can state that those with lower enrichment factors have been mobilized and those that are higher have been mobilized from elsewhere and precipitated. Aluminum, for example, is significantly more enriched than Ti in some samples from limestone protolith (Fig. 3), indicating mobilization from the punk rock and deposition in the oxide layer. Other major element enrichment factors are shown in Figure 5. Calcium and magnesium are significantly depleted in the

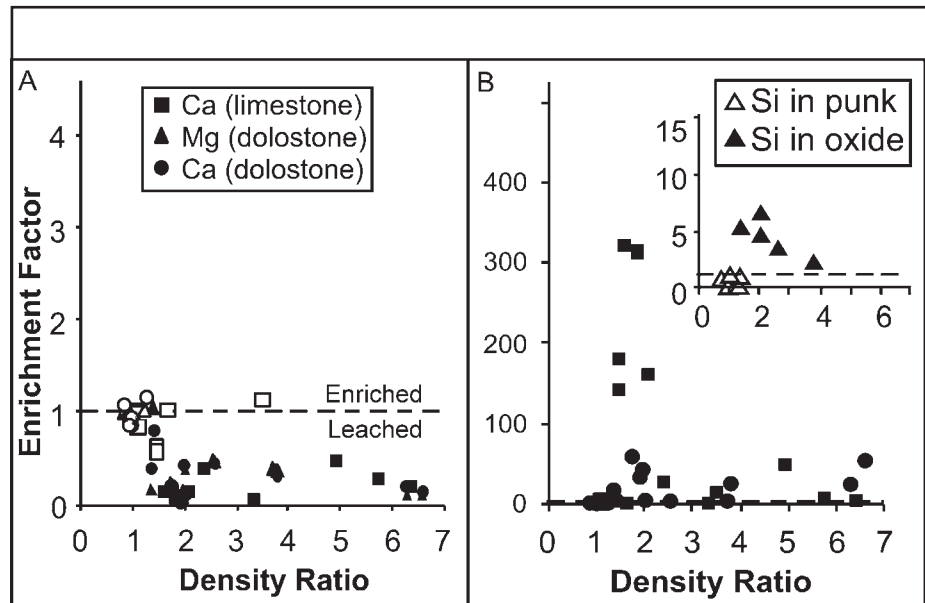

Figure 5: Enrichment factors for major mobile elements in all samples. Squares represent limestone; triangles and squares, dolostone; punk rock in open symbols (A) Ca and Mg. Values above an enrichment factor of 1 are enriched and below 1, depleted or leached. (B) Si enrichment factors in limestone and dolostone. Inset: expanded origin corner showing punk rock (open triangles) and oxides samples (black triangles) from both protoliths.

oxide layer samples whereas most of the punk rock samples exhibit enrichment factors between 1 and 2, indicating that minor dissolution of carbonate has occurred in the punk rock but significant dissolution has taken place in the oxide layer.

Likewise, Si is much less enriched than Al (<500 compared to 1600), and shows evidence of being leached from the punk rock samples (Fig. 5B inset). With the lower enrichment factors in the oxide layer, Si appears to have been removed from the FMD in solution as clays and detrital feldspars are broken down. Thus, removal of Ca, Mg and Si is the principle factor leading to the collapse and formation of the oxide layer.

Within the oxide layer, Fe and especially Mn show major enrichment factors over Ti. In the limestone protolith, Mn is enriched several thousand times over the bedrock concentration. The maximum observed enrichment factors are over 2200 in jet-black samples of the oxide layer, although Mn enrichment is nevertheless substantial in the dark brown samples. Iron, on the other hand, is most enriched in the dark brown samples. These high levels of enrichment for manganese are apparently the result of both leaching from the punk rock and collapse of the oxide layer from chemical weathering.

6. Discussion

Speleosols do not form through simple dissolution of host carbonate. They are mineralogically and chemically distinct from the bedrock. Likewise, our prior work shows that the FMD are distinctly different from the insoluble residue that results from acid dissolution of the bedrock in the laboratory. The ratio of $\text{SiO}_2/\text{Al}_2\text{O}_3$ is about 5 in the insoluble residue whereas the ratio is around 1 in the reddish oxide layer and much less than 1 in many of the dark brown or black samples, indicating a depletion of Si relative to Al (SPILDE et al., 2005). In the speleosols, Ca, Mg, and Si have been leached from the bedrock in forming the punk rock and are further leached at the cave-air interface, resulting in substantial collapse (99%) of the residue into a thin oxide layer. However, there does not appear to be a continuum between punk rock, reddish ferromanganese, and dark oxide layers, i.e. reddish doesn't turn to dark brown ferromanganese. Instead, the colors represent different degrees of dissolution and microbial leaching of the punk rock with subsequent enrichment of Al, Fe and/or Mn into the oxide layer. The red colors are more depleted of Ca, Mg and Si than are some of the dark colors. Nevertheless, both red and black undergo significant changes from the bedrock in addition to dissolution of Ca, Mg and Si, which

are likely removed from the system in aqueous solution. Likewise Fe and Mn are also leached from the punk rock but are precipitated in the outer oxide-rich layer. The strong enrichment of Fe and Mn oxides in the speleosol and the marked increase of Mn:Fe ratio indicate a substantial mass transfer from the punk rock to the outer oxide layer, in addition to removal of insoluble elements Ca, Mg and Si.

6. Conclusions

There is a significant loss of mass from the initial bedrock at the cave wall to form the oxide layer. Furthermore there is evidence of loss of mass in the punk rock, but more importantly, a transfer of mass from the punk rock to the oxide layer. This process can be considered pedogenic in nature and is similar the formation of oxisols. The only difference between cave FMD and oxisols is that the mass transfer in oxisols takes place from the surface downward to the underlying horizon, whereas in the cave, the mass transfer is outward from the subsurface to the oxide layer at the cave-air interface. Otherwise, processes are similar in that silicate minerals (feldspars and clays) are transformed into more Al-rich clays and hydroxide minerals and oxyhydroxides of Al, Fe, and Mn are formed via mass transfer. The mass transfer is facilitated by both chemical and microbial "weathering" akin to surface soils. We therefore propose that cave ferromanganese deposits and corrosion residues be called speleosols. In addition, the term "speleosol" should include those secondary speleothems formed by in-cave weathering, corrosion of primary minerals, and the subsequent replacement by a residual deposit of secondary or tertiary minerals. However, this term should not include such things as allochthonous sediments washed into a cave from the surface. Likewise, it should not include autochthonous sediments such as sand and silt remaining from the dissolution of bedrock during primary speleogenesis.

References

- Buol, S.W. and H. Eswaran, 2000, *Oxisols: Advances in Agronomy* **68**, 151–195.
- Boston P.J., M.N. Spilde, D.E. Northup, K. Mullen, J. Bargar, and R. Carey (2004) Manganese and iron interactions in cave and rock varnish communities. *Eos Transactions of the AGU* **8**, Abstract B53C-1014.
- Boston, P.J., M.N. Spilde, D.E. Northup, L.A. Melim, D.S. Soroka, L.G. Kleina, K.H. Lavoie, L.D. Hose, L.M. Mallory, C.N. Dahm, L.J. Crossey, and R.T. Schelble 2001. Cave biosignature suites: Microbes, minerals and Mars. *Astrobiology Journal* **1** (1), 25–55.

- Brimhall G.H., and W.E. Deitrich (1987) Constitutive mass balance relations between chemical composition, volume, density, porosity, and strain in metasomatic hydrochemical systems: Results on weathering and pedogenesis. *Geochimica et Cosmochimica Acta* **51**, 567–587.
- Brimhall G.H., C. Alpers, and A.B. Cunningham (1985) Analysis of supergene ore-forming processes using mass balance principles. *Economic Geology* **80**, 1227–1254.
- Davis, D.G. 2000, Extraordinary features of Lechuguilla Cave, Guadalupe Mountains, New Mexico. *Journal of Cave and Karst Studies* **62**, 147–157.
- Hill, C.A. 1987, *Geology of Carlsbad Cavern and other caves in the Guadalupe Mountains, New Mexico and Texas: Socorro, NM, New Mexico*. New Mexico Bureau of Mines and Mineral Resources Bulletin, **117**, 150 pp.
- Maltsev V.A. (1997) Minerals of Cupp-Coutunn cave. In *Cave Minerals of The World, 2nd edition*. Carol Hill and Paolo Forti (Eds.), National Speleological Society, Huntsville, AL. p. 323–328.
- Northup, D.E., S.M. Barns, L.E. Yu, M.N. Spilde, R.T. Schelble, K.E. Dano, L.J. Crossey, C.A. Connolly, P.J. Boston, D.O. Natvig, and C.N. Dahm (2003) Diverse microbial communities inhabiting ferromanganese deposits in Lechuguilla and Spider Caves. *Environmental Microbiology* **5**, 1071–1086.
- Queen, J.M. 1994, Influence of thermal atmospheric convection on the nature and distribution of microbiota in cave environments. in *Breakthroughs in Karst Geomicrobiology and Redox Geochemistry*, I.D. Sasowsky and M.V. Palmer, (Eds.), Karst Waters Institute Special Publication Number 1, Charles Town, WV, pp 13–14.
- Rowell D.L. (1994) *Soil Science: Methods and Applications*. John Wiley & Sons, NY., 350 pp.
- Sârbu, S.M. and C. Lascu (1997) Condensation corrosion in Movile Cave, Romania. *Journal of Cave and Karst Studies* **59**, 99–102.
- Spilde, M.N., D.E. Northup, P.J. Boston, R.T. Schelble, K.E. Dano, L.J. Crossey, and C.N. Dahm (2005) Geomicrobiology of cave ferromanganese deposits, a field and laboratory investigation. *Geomicrobiology Journal* **22**, 99–116.
- Sposito, G. (1989) *The Chemistry of Soils*. Oxford University Press, New York, 277 pp.

VENEZUELAN CAVE MINERALS: SECOND REVIEW*FRANCO URBANI*

*Universidad Central de Venezuela. Escuela de Geología. Caracas 1053. Venezuela and
Sociedad Venezolana de Espeleología (SVE), Apartado 47334. Caracas 1041A. Venezuela. urbani@cantv.net*

Abstract

Eleven years following the first published review of Venezuelan cave minerals, we present an updated view of mineral species combined with their respective local cave environments of formation. The new findings came from work done in more than a hundred explorations in caves within different bedrock (carbonate and siliceous rocks) at various elevations and climatic conditions. Minimal sized samples were taken for mineralogical studies in which X-ray diffraction and, when appropriate, a Scanning Electron Microscope with Energy Dispersive Spectrometry were used.

The following minerals have been identified: Carbonates (calcite, aragonite, azurite, dolomite, magnesite, malachite), halides (halite), nitrates (nitratine, sveite), oxide-hydroxides (goethite, ice, lithiophorite, magnetite), phosphates (ardealite, brushite, apatite-(CaCl), apatite-(CaF), apatite-(CaOH), evansite, leucophosphate, struvite, whitlockite), silicates (chalcedony, opal-A, opal-CT, palygorskite, sepiolite), sulfates (aluminite, ammoniojarosite, bassanite, epsomite, gypsum, hexahydrate, koktaite, loncreekite), arsenates (manganberzeliite), organic minerals (pigotite), and native minerals (aluminum).

The larger number of species belongs to phosphates formed within bat guano deposits and their reaction zones with bedrock, but also several sulfates are associated with this environment. In quartzite caves in the Guiana shield, several new morphologies of opal speleothems were found. Like those described in 1974 in Sarisariñama, precipitation of the mineral is facilitated by microorganisms, mainly bacteria. In some occurrences, a transition can be seen from a wet bacterial mat laterally grading to a drier material until solid opal becomes visible. Some zoning of opal stalactites has been interpreted to be due to climatic changes in the Pleistocene-Holocene time span. In one quartzite cave native aluminum was identified using several techniques and becomes the world first occurrence of this species as a cave mineral. It was found as a powdery efflorescence on the cave wall, but the speleothem is inactive not allowing the observation of formation conditions.

In Sociedad Venezolana de Espeleología cave explorations trips, most members are trained to search for unusual speleothems, particularly those displaying an indistinct form of efflorescence and wall crusts morphology, so this has allowed Venezuela to recognize a large diversity of mineral species.

SPELEOTHEM ONTOGENY: LESSONS FROM CRYSTAL GROWTH THEORY AND TECHNOLOGY

WILLIAM B. WHITE

*Department of Geosciences and Materials Research Institute, The Pennsylvania State University,
University Park, PA 16802, USA*

Extended Abstract

Mineral ontogeny is the study of the growth and development of mineral deposits in general and, in the present context, speleothems in particular. Previous researchers, mainly in Russia, have developed a nomenclatural hierarchy based on the forms and habits of individual crystals and the assembly of individual crystals into both monomineralic and polyminerale aggregates (i.e. speleothems). Although investigations of the growth processes of speleothems are sparse, there is a large literature on growth processes of speleothem minerals and related crystals in the geochemical and materials science literature. The purpose of the present paper is to sort through the various concepts of crystal growth and attempt to relate these to observations on speleothems and to the Russian conceptual framework of mineral ontogeny. SELF and HILL (2005) give the ontogeny hierarchy and SELF and HILL (2003) provide examples of the various forms.

As might be expected, the most complete information is available for the first level mineral individuals. Splitting, twinning, and other deviations from well-formed single crystals have been intensively studied, mostly with a view to avoiding them in the production of technologically important crystals. Likewise, investigations of second level assemblages of individual mineral grains into aggregates can be found in the microstructure of ceramics and metals. At the third and fourth levels, assemblages of aggregates into speleothems becomes more specific to cave studies with less guidance from other literature.

The trigonal calcite structure consists of alternating layers of Ca^{2+} ions and carbonate ion with the layers perpendicular to the *c*-axis which then becomes the fast growth direction. Calcite growth is highly sensitive to minor impurities that may poison growth in certain crystallographic directions or may poison growth altogether. Extensive recent research using the atomic force microscope (AFM) provides many details of calcite growth including the transition from growth on screw dislocations to growth by two-dimensional nucleation. Organic impurities modify growth surfaces including the formation of hopper crystals. There is some evidence that large planar organic molecules such as humic

and fulvic acids may act as templates on which calcite crystals can nucleate and growth.

The deposition of aragonite speleothems requires supersaturation in excess of the aragonite solubility curve and even more greatly in excess of the calcite solubility curve. Some mechanism is needed to prevent the nucleation of calcite or to enhance the nucleation of aragonite. Commonly the mechanism is assumed to involve the impurities Mg^{2+} and Sr^{2+} . AFM studies reveal that Mg^{2+} poisons calcite growth by blocking deposition sites on dislocations, thus allowing supersaturation to build up past the aragonite solubility curve. An electron microprobe study has shown that Sr^{2+} precipitates as a Sr-rich nucleus with the aragonite structure which acts as a template for aragonite growth.

Split crystals are formed where impurities pile up ahead of the growing interface until they finally reach a concentration where they act as heterogeneous nuclei. Continued growth is in diverging but non-crystallographic directions. True spherulitic growth (as distinguished from radial growth on a heterogeneous nucleus) requires a non-classical, highly distorted nucleus so that continued growth is equal along radial directions. Examples of twinned growth, dendrite growth, and spherulitic growth are common in the crystal growth literature and can be used to interpret the corresponding cave forms.

Gypsum is built up of layers of calcium and sulfate ions bound together only by hydrogen bonding across facing layers of water molecules, giving gypsum its perfect {010} cleavage. Growth is fastest along the [001] direction. Gypsum needles are elongated on [001]. Gypsum needles are re-entrant twins with the twin plane parallel to the needle axis. Gypsum flowers are fiber bundles with the same [001] crystallographic orientation along the fiber axis but random [100] and [010] orientations between fibers. A special form of fiber growth is the whisker in which growth along the fiber is controlled by a single screw dislocation. Angel hair gypsum has the morphology of whiskers.

For calcite, the most common mineral in speleothems, the activation energy for two dimensional nucleation (required for the growth of large single crystals) is almost the same as the activation energy for three-dimensional nucleation (which would result in the growth of many small crystals). The transition from monocrystalline speleothems, to oriented-grain speleothems, to random-oriented-grain speleothems can be quantitatively explained in terms of supersaturation. Common speleothem microstructures such as the palisade arrangement of grains is a combination of geometrical constraints and growth rate competition.

Polymineralic aggregates are a more complex issue. As the first-formed crystals grow, the chemistry of the fluids change, and thus different minerals may be nucleated. There occur helictite-like and nodular structures with a core of calcite, and outer sheaf of aragonite, and blobs of hydromagnesite moonmilk at the tips of the aragonite crystals. Cave calcites tend to have a low magnesium content. As the calcite core grows, the magnesium concentration in the residual solution builds up, eventually poisoning the calcite growth thus forcing the nucleation of aragonite. The final precipitate is hydromagnesite.

In conclusion: The mineral ontogeny hierarchy provides a useful classification scheme for the various ways that minerals grow and interconnect in speleothems. To use the classification as an interpretative tool it is necessary to understand underlying growth mechanisms, which means probing surfaces, interfaces, the adsorption of impurities, and the evolving chemistry of thin fluid films. Surface characterization tools such as the scanning electron microscope and the atomic force microscope provide a portion of the information. Remaining to be developed are tools for microchemistry (or nanochemistry) of the extremely low volume fluids from which many speleothems are deposited.

References

- SELF, C.A., and C.A. HILL (2003) How speleothems grow: An introduction to the ontogeny of cave minerals. *Journal of Cave and Karst Studies* 65, 130–151.
- SELF, C.A., and C.A. Hill (2005) An introduction to genetic mineralogy and the concept of “ontogeny of cave minerals.” *Proceedings of the 14th International Congress of Speleology, Kalamos*, 1, pp 125–129

Symposium 5

MICROBIOLOGY AND GEOMICROBIOLOGY OF CAVE AND KARST ENVIRONMENTS

**Arranged by:
Hazel Barton
Juan Miguel Gonzalez**

IRON-MANGANESE COLONIES OF MICROORGANISMS FROM ZOLOUSHKA CAVE (UKRAINE)

VIACHESLAV ANDREYCHOUK

University of Silesia, Faculty of Earth Sciences, Będzińska 60, 41-200 Sosnowiec, Poland

Abstract

Zoloushka Cave is one of the largest gypsum caves in the world (length > 90 km, volume ~ 650.000m³), located in Western Ukraine (Northern Bukovina). It is a typical hypogenic cave – a maze which developed in the 25 m thick layer of Miocene gypsum as a result of ascending underground water in its transit to the regional erosional base – the Prut river. The galleries of the cave are located below a contemporary erosion base. The cave maze was uncovered about 50 years ago during activities associated with the gypsum quarry, which is still actively worked. Before the exploitation of the gypsum, the cave's corridors were totally filled with water, which was highly mineralised (4-5 g/L) and saturated with H₂S (over 100 mg/L). Geochemical conditions in the water-filled environment of the cave were clearly reductional. Due to the excavation of gypsum, which deepened the quarry, and the gradual pumping out of the underground water, the gypsum layer and practically the entire cave was drained. The drainage of the karst aquifer was accompanied by a gradual change from reducing to oxidizing conditions. The influx of O₂ into the cave environment promoted the development of different and interesting geochemical processes (e.g. deposition of large amounts of iron and manganese hydroxides on the walls and bottoms of corridors) and an “explosion” of activity of different microorganisms. Cave bacteria take part in these geochemical transformations on a large scale, giving them a similar importance as biogeochemical processes. Side by side with well known bacterial groups (e.g., *Desulfovibrio desulfuricans*, *Thiobacillus ferrooxidans*, *Thiobacillus thioparus*, *Thiobacillus thiooxidans*, *Ferrooxidans TuF*, *Methanobacterium formicium*, *Pseudomonas methanica*, *Pseudomonas denitrificans*, *Clostridium* etc.), known to be active in this and other geochemical environments, several new groups, not yet identified, were determined to be present in the cave. Special attention was paid to iron and manganese fungi-shaped microorganisms. They occur in certain parts of the cave as aggregates of iron-manganese deposits of characteristic shape, showing that they represent formerly large organo-mineral colonies. The most interesting among them in terms of morphology are stalagmite-like constructions, empty inside, 0.5 m high and 5-20 cm in diameter. Besides these stalagmite colonies, other locations have pipe-like “roof colonies”, similar in appearance to nests of wild bees. In other places, several-centimeter sized aggregates with pipe-like “branches” similar to sea corals, were identified. The microscopic investigations have revealed that the walls of the ferruginous pipes are built of tiny fungi-like organisms which function in close proximity to iron-bacteria.

ATACAMA DESERT CAVES: ANALOGUES FOR POSSIBLE MICROBIAL LIFE HABITATS ON MARS

A. AZÚA-BUSTOS¹, C. GONZÁLES², R. MANCILLA-VILLALOBOS¹, L. SALAS¹, J. ZÚÑIGA¹ AND R. VICUÑA¹

¹Departamento de Genética Molecular y microbiología, Facultad de Ciencias Biológicas,
Pontificia Universidad Católica de Chile, Santiago, Chile.

²Departamento de Ciencias Químicas y Farmacéuticas, Universidad Arturo Prat, Iquique, Chile.

Abstract

Caves represent an interesting model habitat to approach the search for life elsewhere in the Solar System, since they offer a protected environment from the harsher outside prevailing conditions. Here we show that in different coastal caves of the ancient Atacama Desert, a well-recognized Mars analog, a surprising variety of microbially based ecosystems and unexpected species can be found. In one of these caves, a member of the ancient eukaryotic red algae *Cyanidium* group was found forming a seemingly phototroph-monospecific biofilm at the dimmest lighted areas of the cave. Our work suggests that this species, *Cyanidium* sp. Atacama, could be a new member of a recently proposed novel monophyletic lineage of mesophilic *Cyanidium* spp., distinct from the remaining three other lineages which are exclusively thermo-acidophilic. This new species of *Cyanidium* is using a niche inside the cave where apparently no other phototrophs can thrive due to the extremely low light levels available. This suggests that it may have reached the limits of photosynthetic efficiency at atmospheric conditions on Earth. This finding could apply to a potential scenario of a cave in Mars. Hypothetically, a phototrophic microorganism could be found well protected inside a cave using minimum photon flux levels coming from a nearby entrance which could be enough to enable the photosynthetic processes critical for survival.

**MATHEMATICAL MODELING OF BIOLOGICAL AND PHYSICAL PROCESSES
IN COMPLEX MAZELIKE CAVE BIOMATS AND DESERT CRUSTS**

P.J. BOSTON^{1,2}, J. CURNUTT³, E. GOMEZ³, K.E. SCHUBERT³, D.E. NORTHUP⁴, H. SUN⁵,
C.P. MCKAY⁶, A. RINEHART²

¹ National Cave and Karst Research Institute, Carlsbad, NM 88220

² Dept. Earth & Environmental Sci., New Mexico Tech., Socorro, NM 87801

³ Dept. Computer Science, California State Univ., San Bernardino, CA 92407

⁴ Dept. Biol., Univ. New Mexico, Albuquerque, NM 87131

⁵ Desert Res. Inst., Las Vegas, NV 89119

⁶ NASA Ames Res. Ctr., Moffett Field, CA 94035

Abstract

Complex, maze-like or hieroglyphics-like patterns on cave walls around the world have drawn attention from the caving community and been referred to as “vermiculations”, i.e. worm-like patterns. To date, no comprehensive picture of the mechanisms involved in the formation of these patterns have been offered although suggestions have appeared in the literature. Interestingly, very similar patterns also appear in other biological phenomena including the so-called cryptogamic crusts that form on aridland soils around the world.

Visually striking examples of such patterns were observed in a sulfuric acid cave in Tabasco, Mexico. These materials were noticed to contain a large amount of living biomass and biofilm and given the moniker “biovermiculations” to indicate the large biological component. In subsequent years, our team and other colleagues have observed similar features in caves around the world, and in lavatubes, in mine adits, and even on the walls of Mayan ruins. This has resulted in questions about formation mechanisms for these structures that must explain occurrences both in caves and other surface and subsurface settings.

We have produced patterns using cellular automata modeling that present the same geometric appearance as the biovermiculations and cryptogamic crusts. Pattern variations can be created by altering various rules within the schema. We are comparing modeling results to real biovermiculations and cryptogamic crusts in an attempt to infer which processes, (physical, chemical, and biological), may be producing these patterns in real systems. Details of laminar and turbulent flow, surface roughness, viscosity, intrinsic cellular reproductive geometries, and particulates present (e.g. clays or mineral particles) all appear to contribute to the patterns seen across a large number of occurrences. Underlying lithologic or geochemical differences, and even some features of the biological systems (e.g. photosynthetic vs. heterotrophic or chemotrophic) do not appear to be the predominant controlling factors.

Cellular automata modeling has the potential to be a valuable research tool to explain these and other phenomena associated with similar complex interactions of biological systems with physical and chemical processes. Caves are an excellent place to study them because of relative protection from surface weather and other disturbances.

TRACING THE ORIGINS OF CHROMOPHORIC DISSOLVED ORGANIC MATTER IN KARST AQUIFERS

KATHLEEN M. BRANNEN¹, ANNETTE SUMMERS ENGEL¹ and JUSTIN E. BIRDWELL²

¹Department of Geology & Geophysics, Louisiana State University, Baton Rouge, LA 70803 USA

²Cain Department of Chemical Engineering, Louisiana State University, Baton Rouge, LA 70803 USA

Dissolved organic matter (DOM) is important to cave and karst ecosystem energetics because it is a source of organic carbon for heterotrophs. In this study, chromophoric DOM in cave and karst waters was characterized using excitation-emission matrix (EEM) fluorescence spectroscopy to delineate different possible sources of organic carbon in karst ecosystems. The fluorescence signature of DOM provides information on the relative contribution of terrestrial (allochthonous) and microbial (autochthonous) sources. Terrestrial DOM sources are generally well characterized from caves and karst, being derived primarily from plant and soil organic matter. However, autochthonous organic carbon in karst is not well understood because it is unclear how microbes contribute to DOM types and abundances, either as primary DOM sources or during the breakdown process of allochthonous material. Therefore, we focused this work on cave and spring systems where chemolithoautotrophic microbial activity has been previously studied. Cave and spring water spectra contained intense peaks indicative of the fluorescent amino acids tryptophan and tyrosine. DOM extracted from microbial mats also contained these amino acid peaks, as well as two peaks that we attribute to the coenzyme nicotinamide adenine dinucleotide (NADH). In some karst water samples, fulvic acid-like peaks were observed, but were at significantly shorter emission wavelengths than those observed for surface water humic substances. These peaks were also distinct from what would be expected from plant-derived humic and fulvic DOM. The lack of fluorescence signatures typically attributed to terrestrial DOM confirms that the examined karst systems had insignificant allochthonous contributions. The diverse, microbially derived DOM extracellular substances can be readily utilized by heterotrophs within the ecosystem, suggesting that the role of microbes cycling DOM, either from allochthonous or autochthonous sources, may be more important than previously considered.

1. Introduction

Dissolved organic matter (DOM) is a nearly universal component in natural waters and is involved in a wide range of physical, chemical, and biological processes in aquatic ecosystems. DOM is made up of a complex mixture of native and degraded biomolecules derived from plant, animal, and microbial sources. The chemical components of DOM are generally divided into humic and non-humic substance categories. Aquatic humic substances are composed of humic and fulvic acids, while non-humic substances include a wide range of natural compounds, such as proteins, carbohydrates, lipids, and their degradation products.

Both humic and non-humic substances contain chemical moieties that fluoresce when exposed to ultraviolet and visible light, making it possible to study DOM using fluorescence spectroscopy. Consequently, DOM fluorescence properties provide a wealth of qualitative information for source, composition, concentration, and bioavailability. Fluorescence is non-destructive, rapid, and sensitive enough to be used at natural abundance

concentrations. Fluorescence spectroscopy has been applied to the study of DOM in natural waters using a range of different methods. One of the most useful techniques is excitation-emission matrix (EEM) fluorescence spectroscopy (Coble, 1996). This method combines a series of emission spectra at different excitation wavelengths into a three dimensional or contour plot, and allows for rapid visual identification of characteristic DOM fluorophores (Coble, 1996). Data can be mined and analyzed using a range of different methods based on the needs of the investigator and the nature of the waters being characterized (Baker and Genty, 1999; McKnight et al., 2001; Chen et al., 2003; Holbrook et al., 2006; Hudson et al., 2007).

One of the most often exploited aspects of EEM fluorescence data is the differentiation of DOM signatures of terrestrially-derived (e.g., soil and aquatic humic substances) and microbially-derived (e.g., proteins, peptides, enzymes and amino acids) organic matter. Figure 1 illustrates the different biological and humic-like fluorophores often observed in natural water samples (e.g., Coble, 1996; Baker and Genty, 1999; McKnight et

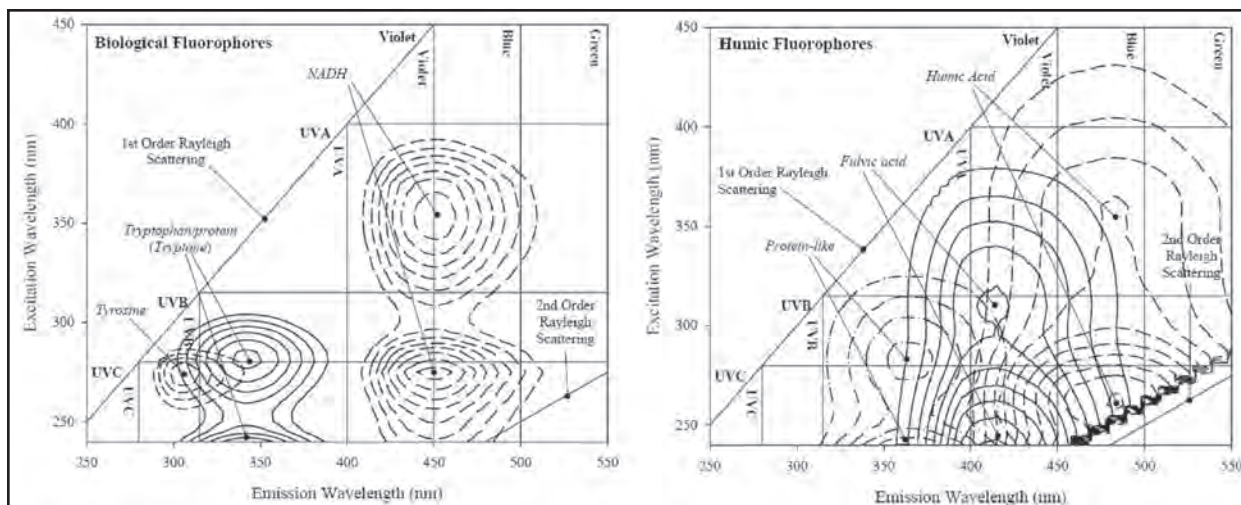

Figure 1. Peak positions for biological (left) and humic fluorophores (right); locations of Rayleigh scattering bands and ultraviolet and visible light regions also shown. Sources for peak positions are cited in the text. The EEMs are interpreted like topographic maps, with tight contours representing steep curves and closed contours being peaks.

al., 2001; Chen et al, 2003; Yamashita and Tanoue, 2003; Alberts and Takacs, 2004; Her et al., 2004; Nguyen et al., 2005; Holbrook et al., 2006; Henderson et al., 2008; Cook et al., 2009; Birdwell and Engel, in review). Isolated humic and fulvic acids have been identified to contain protein-like fluorescence (Fig. 1, right panel); however, these components are usually not major contributors and are only observed when spectral deconvolution techniques are applied to large datasets (Holbrook et al., 2006; Cook et al., 2009).

In most cave and karst ecosystems, it is assumed that the majority of the organic carbon is brought into the system by meteoric waters from the surface, such as by dripwaters or sinking streams. Therefore, allochthonous DOM in karst is expected and should consist primarily of recalcitrant, plant-derived soil and aquatic humic and fulvic acids. But, humic substances can also be produced from microbial primary production and heterotrophic processing of DOM within a microbial ecosystem, as demonstrated from studies of algal-derived fulvic acids from the open ocean and Antarctic lakes that are populated by photosynthetic microbes (McKnight et al., 2001). In microbial surface habitats, humic substances form by the photooxidation of microbial lipids and fatty acids (McKnight and Aiken, 1998). Isolated and characterized fulvic acids from algal (Her et al., 2004; Nguyen et al., 2005; Henderson et al., 2008) and wastewater activated sludge (Chen et al., 2003) cultures indicate that microbial DOM has fluorescence properties similar to terrestrial and aquatic humic and fulvic substances, but with emission peaks at shorter wavelengths (Alberts and Takacs, 2004).

Therefore, we hypothesized that only allochthonous humics

should be found in caves, as humics would not be produced *in situ* because degradation of organics by photooxidation would not be possible in the subsurface; instead, microbial breakdown reactions should dominate the mineralization process. By distinguishing the relative contributions of *ex situ* terrestrial and *in situ* microbial DOM using fluorescence spectroscopy, the sources of DOM to karst ecosystems could be tracked. Alternatively, if humic substances are produced in caves and have fluorescence signatures similar to those observed in surface waters, then the application of fluorescence to DOM tracing in cave and karst will be more complicated and possibly intractable. Because much is known about terrestrial DOM properties, in this study we first needed to establish what microbial DOM signatures existed in cave and karst aquifer systems. We evaluated the specific fluorescence properties and features of microbially produced chromophoric DOM from systems where chemolithoautotrophic microbial communities are abundant (e.g., Vlasceanu et al., 2000; Engel et al., 2004; Porter et al., 2009). Many of the sampled sites were sulfidic and had been previously shown to have limited hydrological communication with the surface.

2. Materials and Methods

2.1. Sample collection

Samples originated from various sulfidic and non-sulfidic, thermal and non-thermal cave and karst sites throughout the continental United States, Slovenia, and Italy using methods previously described (Porter et al., 2009). Sites included: Lower Kane Cave, Wyoming, USA; Edwards Aquifer, Texas, USA; Big Sulphur Cave, Kentucky, USA; Sulfur Springs, Indiana, USA; and Glenwood Hot Spring, Colorado, USA; various locations within the Frasassi

Caves, Italy; and three sulfidic karst springs in Slovenia. A non-karst sulfidic spring was also sampled for comparison (White Sulphur Springs, Louisiana, USA). This spring is sourced from carbonate rocks buried under 100s of meters of Mississippi River sediment (J. Hanor, pers. comm.). The Lower Kane, Big Sulphur, and Frasassi caves are sulfidic and the microbial mats from these systems have been previously well characterized to consist of known chemolithoautotrophic groups (Engel et al., 2004; Porter et al., 2009). The Edwards Aquifer, Sulfur Springs, Glenwood Hot Spring, and the springs in Slovenia had microbial mats and biofilms associated with aquifer and spring waters, but it is not yet known how numerous chemolithoautotrophs are in the communities (Engel, unpublished data).

2.2. Sample processing

Water samples were filtered in the field using a 0.45- μm Whatman glass fiber filter (GF/F, autoclaved and precombusted at 500°C) and a 0.2- μm PTFE filter (Millipore, Bedford, MA) in tandem and stored cold until processed in either Nalgene bottles or polypropylene centrifuge tubes. Microbial mats were collected aseptically using tweezers and stored in centrifuge tubes. The mat samples were centrifuged to extract “mat water,” which we considered to be extracellular DOM. Mat water was filtered using 0.22 μm PVDF membrane filters prior to analysis. The centrifuged mat pellet was then freeze-dried, pulverized, and washed with DI water for 24 hr to obtain intracellular (water-extractable) DOM.

2.3. Fluorescence analysis

Fluorescence measurements were made using either a SPEX Fluorolog-3 or a Varian Cary Eclipse spectrophotometer with the following settings: 41 emission scans ($\lambda_{EX} = 250 - 550$ nm, 2.5 nm steps; $\lambda_{EM} = 250 - 450$ nm, 5 nm steps), PMT voltage 800V, EX/EM slits 5 nm each, and an integration time 0.1 sec. Analyses were done in a 1-cm quartz cuvette at room temperature (22°C). Instrument stability was determined using the Raman peak of deionized water excited at 348 nm with emission monitored at 395 nm. Raman intensities were consistent during each session with values varying less than 2% between runs. Samples were analyzed in signal/reference mode where the fluorescence emission intensity was normalized to the intensity of the lamp at the particular excitation wavelength applied. EEM fluorescence spectra were obtained by collecting a series of forty-one emission scans (250–550 nm, 2.5 nm intervals) at 5 nm excitation wavelength intervals between 250 and 450 nm. EEM contour plots were assembled by combining the individual emission spectra. Spectral corrections for primary and secondary inner filter effects

were made using absorbance spectra collected (Lakowicz, 1999) using a Shimadzu UV-3101PC spectrophotometer in a 1-cm cuvette over the 200–600 nm wavelength range with deionized water as the reference. Raman scattering was removed from EEMs by subtracting a blank spectrum collected on pyrogen-free deionized (>18.1 M Ω) water from each sample spectrum. Rayleigh scattering effects were edited from each spectrum, following correction and blank subtraction.

3. Results and Discussion

One of the main objectives of this study was to track terrestrial and microbial DOM sources in karst. In order to meet this goal, however, we needed to establish what cave and karst microbial DOM signatures would be like, as little is known about microbial contributions to DOM in the subsurface. The majority of spring and cave water samples had low to moderate total organic carbon concentrations (< 5 mg L⁻¹), consistent with other studies from karst settings (e.g., Farnleitner et al., 2005; Einsiedl et al., 2007). The water DOM fluorescence spectra contained many of the characteristic peaks observed in other studies of marine and terrestrial DOM, but were generally dominated by peaks indicative of fluorescent amino acids tyrosine and tryptophan (Yamashita and Tanoue, 2003). Many of the cave water samples had humic-like fluorescence, but these spectra were significantly blue-shifted from what is typically found for soil and surface water derived humics. The peaks indicating humic-like substances have been described by Coble (1996) as peaks *A* ($\lambda_{EX} = 240-260$ nm, $\lambda_{EM} = 380-460$ nm), *C* ($\lambda_{EX} = 340-360$ nm, $\lambda_{EM} = 420-480$ nm), and *M* ($\lambda_{EX} = 290-315$ nm, $\lambda_{EM} = 380-420$ nm), which are also described as UV-excited, visible-excited, and marine humic fluorophores, respectively.

Because humics are not produced in caves by photooxidation-induced degradation, we hypothesized that only allochthonous humics should be identified. All cave and karst waters examined in this study lacked any significant terrestrial fluorescence signatures and instead displayed strong microbial fluorescence features (e.g., tryptophan and tyrosine peaks) (Fig. 2). The lack of allochthonous DOM sources was most striking aspect in the cave and karst spectra, and especially when the karst spectra were compared to the non-karst sulfidic spring from Louisiana, which had a strong humic acid peak (Fig. 3, far right panel). The results from the cave and karst waters call into question the assertion that *in situ* DOM production in karst aquifers is negligible and that organic carbon is primarily from allochthonous sources (Pronk et al., 2006).

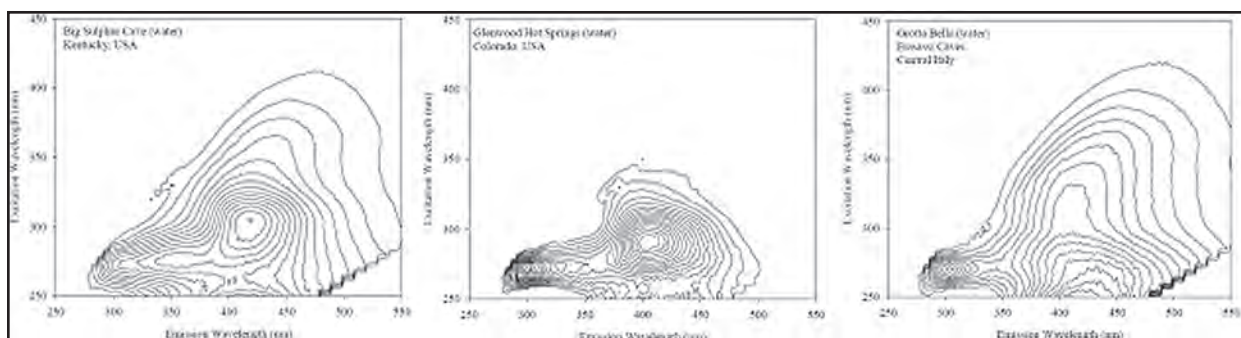

Figure 2. Representative spectra of waters from karst caves and springs. The EEMs are interpreted like topographic maps, with tight contours representing steep curves and closed contours being peaks.

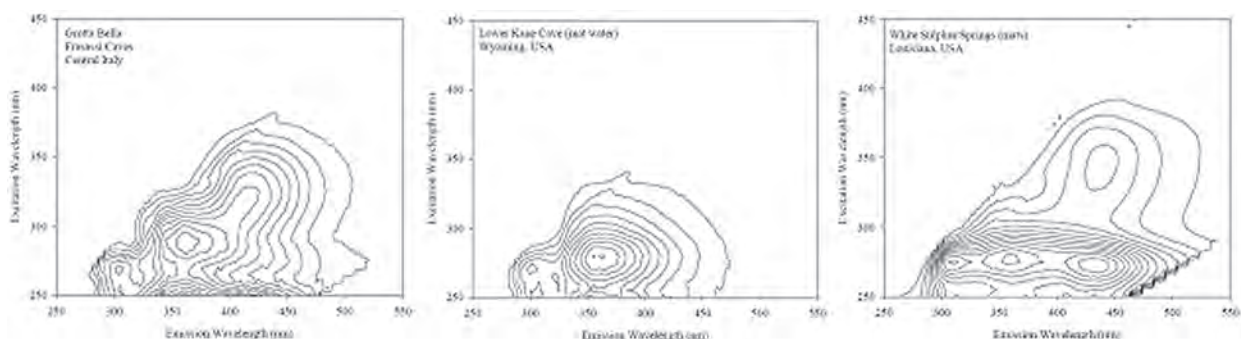

Figure 3. Representative fluorescence spectra of microbial mat waters. The EEMs are interpreted like topographic maps, with tight contours representing steep curves and closed contours being peaks.

The extracellular organic matter and intracellular organic matter within the microbial mats possessed intense protein-like fluorescence and, in many cases, a set of emission peaks at ~450 nm attributed to nicotinamide adenine dinucleotide (NADH) (Fig. 1). The intracellular organic matter samples also contained a variety of distributions of tyrosine and tryptophan signatures, indicating the presence of different proteins and peptides. We interpret the fluorescent amino acid signatures in the karst systems to represent diverse extracellular substances that can be readily utilized by heterotrophs within the cave and karst aquifer systems. The absence of the NADH peaks from the microbial extracellular organic matter, and from the surrounding cave and spring waters, indicates how biologically labile this form of DOM is in these systems.

Especially interesting were the results from the Edwards Aquifer samples that showed a lack of terrestrial fluorescence signatures and strong amino acid signatures, suggesting that allochthonous DOM is either degraded or filtered within or before reaching the aquifer system. These results could be used to support the hypothesis that microbial heterotrophs dominate the mineralization process in the subsurface. The rarer humic-like signatures, resembling those produced in algal cultures exposed to solar equivalent irradiation, could represent microbially-degraded terrestrial humic substances or recalcitrant DOM produced *in situ* by an unknown

mechanism. Recent studies demonstrate that microbial activity can be significant within karst aquifers (Farnleitner et al., 2005; Einsiedl et al., 2007; Birdwell and Engel, in review), and the role of microbes cycling DOM, either from allochthonous or autochthonous sources, may be more important than previously considered.

Acknowledgments

We would like to thank Isiah Warner and Robert Cook of the LSU Chemistry Department and Byron Taylor of Varian Inc. for equipment access. We thank Geary Schindel and other scientists at the Edwards Aquifer Authority for access to wells, field assistance, chemical analyses, and down well video. John Waugh and David Mahula at the San Antonio Water System assisted in the field and in well access. The work was funded the Louisiana State University Council of Research and the Louisiana Board of Regents [LEQSF(2006-09)-RD-A-03] to A.S.E.

References

ALBERTS, J.J. and M. TAKACS, (2004) Total Luminescence Spectra of IHSS Standard and Reference Fulvic Acids, Humic Acids and Natural Organic Matter: Comparison of Aquatic and Terrestrial Source Terms. *Organic Geochemistry* 35, 243–256.

- BAKER, A. and D. GENTY, (1999) Fluorescence Wavelength and Intensity Variations of Cave Waters. *Journal of Hydrology* **217**, 19–34.
- BIRDWELL, J.E. and A.S. ENGEL, (2009) Impact of Recharge on Chromophoric Dissolved Organic Matter in the Edwards Aquifer, Central Texas. *Journal of Cave and Karst Studies* (In Press, accepted February 2009).
- CHEN, W., P. WESTERHOFF J.A. LEENHEER, and K. BOOKSH, (2003) Fluorescence Excitation-Emission Matrix Regional Integration to Quantify Spectra for Dissolved Organic Matter. *Environmental Science and Technology* **37**, 5701–5710.
- COBLE, P. (1996) Characterization of Marine and Terrestrial DOM in Seawater Using Excitation-Emission Matrix Spectroscopy. *Marine Chemistry* **51**, 325–346.
- COOK, R.L., J.E BIRDWELL, ., C.V. LATTAO, and M. LOWRY, (2009) A Multi-Method Comparison of Atchafalaya Basin Surface Water Organic Matter Samples. *Journal of Environmental Quality* **38**, 702–711.
- EINSIEDL, F., N. HERTKORN M. WOLF M. FROMMBERGER P. SCHMITT-KOPPLIN, and B.P. KOCH, (2007) Rapid Biotic Molecular Transformation of Fulvic Acids in a Karst Aquifer. *Geochimica et Cosmochimica Acta* **71**, 5474–5482.
- ENGEL, A.S., M.L. PORTER L.A. STERN S. QUINLAN, and P.C. BENNETT, (2004) Bacterial Diversity and Ecosystem Function of Filamentous Microbial Mats from Aphotic (Cave) Sulfidic Springs Dominated by Chemolithoautotrophic “*Epsilonproteobacteria*”. *FEMS Microbiology Ecology* **51**, 31–53.
- FARNLEITNER, A.H., I. WILHARTITZ G. RYZINSKA A.K.T. KIRSCHNER H. STADLER M.M. BURTSCHER R. HORNEK U. SZEWCZYK G. HERNDL, and R. MACH, (2005) Bacterial dynamics in spring water of alpine karst aquifers indicates the presence of stable autochthonous microbial endokarst communities. *Environmental Microbiology* **7**, 1248–1259.
- HENDERSON, R.K., A. BAKER S.A. PARSONS and B. JEFFERSON, (2008) Characterisation of Algogenic Organic Matter Extracted from Cyanobacteria, Green Algae and Diatoms. *Water Research* **42**, 3435–3445.
- HER, N., G. AMY H.R. PARK and M. SONG, (2004) Characterizing Algogenic Organic Matter (AOM) and Evaluating Associated NF Membrane Fouling. *Water Research* **38**, 1427–1438.
- HOLBROOK, R.D., J.H. YEN, and T.J. GRIZZARD, (2006) Characterizing Natural Organic Material from the Occoquan Watershed (Northern Virginia, US) using Fluorescence Spectroscopy and PARAFAC. *Science of the Total Environment* **361**, 249–266.
- HUDSON, N.; A. BAKER, and D. REYNOLDS, (2007) Fluorescence Analysis of Dissolved Organic Matter in Natural, Waste and Polluted Waters – A Review. *River Research and Applications* **23**, 631–647.
- MCKNIGHT D.M. and G.R. AIKEN, (1998) Sources and Age of Aquatic Humus. Chapter 1 in *Aquatic Humic Substances*, D.O. Hessen, and L.J. Tranvik, (Eds.), Springer-Verlag, Berlin, p. 9–39.
- MCKNIGHT, D.M., E.W. BOYER P.K. WESTERHOFF P.T. DORAN T. KULBE, and D.T. ANDERSEN, (2001) Spectrofluorometric Characterization of Dissolved Organic Matter for Indication of Precursor Organic Material and Aromaticity. *Limnology and Oceanography* **46**, 38–48.
- NGUYEN, M.L., P. WESTERHOFF L. BAKER Q. HU M. ESPARZA-SOTO, and M. SOMMERFELD, (2005) Characteristics and Reactivity of Algae-Produced Dissolved Organic Carbon. *Journal of Environmental Engineering* **131**, 1574–1582.
- PORTER, M.L., A.S. ENGEL T.C. KANE, and B.K. KINKLE, (2009) Productivity-diversity relationships from chemolithoautotrophically based sulfidic karst systems. *International Journal of Speleology* **38**, 27–40.
- PRONK, M., N. GOLDSCHIEDER, and J. ZOPFI, (2006) Dynamics and interaction of organic carbon, turbidity and bacteria in a karst aquifer system. *Hydrogeology Journal* **14**, 473–484.

VLASCEANU, L., S.M. SARBU, A.S ENGEL, and B.K. KINKLE, (2000) Acidic Cave-Wall Biofilms Located in the Frasassi Gorge, Italy. *Geomicrobiology Journal* **17**, 125–139.

YAMASHITA, Y. and E. TANOUE, (2003) Chemical Characterization of Protein-like Fluorophores in DOM in Relation to Aromatic Amino Acids. *Marine Chemistry* **82**, 255–271.

IRON(III) BIO-MINERALIZATION AND ITS SIGNIFICANCE IN ODYSSEY CAVE, BUNGONIA, NEW SOUTH WALES, AUSTRALIA

ANNALISA K. CONTOS¹, JULIA M. JAMES²

¹*Sydney University Speleological Society and Australian Speleological Federation
Water Futures, PO Box 212 Killara NSW 2071, Australia*

²*Sydney University Speleological Society and Australian Speleological Federation
The School of Chemistry, F11, The University of Sydney, NSW 2006, Australia, jmj@chem.usyd.edu.au*

Extended Abstract

Recent developments in technology have allowed an understanding of the role of micro-organisms in forming minerals in caves. This study of iron (III) bio-mineralization has shown that it has potential to preserve paleoclimatic data encapsulated within cave sediments and that magnetotactic bacteria could be the source of the magnetism found in speleothems and sediments.

Odyssey Cave, Bungonia, New South Wales, Australia, is in Silurian limestone and its catchment is on shales, slates, phyllites, quartzites, mudstones, and siltstones. Iron minerals were exposed as layers in the banded sediment banks in the final chamber of the cave. The sediments were exposed when the level of the lake in the final chamber was lowered by excavations at a cave spring. The banded sediments were initially interpreted as being inorganic in origin (James, 1973). The site was regarded as an ideal site for the study of Precambrian ironstone formation. Our recent studies have shown that bio-mineralization is implicated in their formation (Contos, 1998).

On the surface of the lake in the final chamber, a bright orange microbial mat forms intermittently. Powder X-ray diffraction, Fourier transform infrared spectroscopy, lake thermo-analysis, and electron microscopy were used to identify the micro-organisms in the mat. Four characteristic morphologies were observed; smooth and encrusted sheaths, characteristic of *Leptothrix* spp., twisted stalks diagnostic of *Gallionella* sp. and thin strands, most likely arising from breakdown of the *Gallionella* stalks. The major mineral associated with the mat was poorly crystalline ferrihydrite.

Over a period of 30 years, regular visitors to the cave had recorded that the bacterial mat was present when there was high carbon dioxide (CO₂) in the cave atmosphere. For safe entry (James et al., 1975) to the final chamber of Odyssey Cave, CO₂ levels were always measured. Atmospheric oxygen (O₂) was measured in the eight-year study of coldwater mineralisation in Odyssey Cave as

described in James (1975). The cave atmosphere is Type II foul air (James, 1977) with its characteristics being increased CO₂ and nitrogen, and decreased O₂, that is, the CO₂ is produced by the respiration of micro-organisms. In the recent study, water chemical and atmospheric carbon dioxide measurements were again used to further establish the conditions under which the bacterial mat thrives. Several parameters were measured in the cave. Those parameters pertinent to this discussion are atmospheric CO₂, dissolved oxygen, pH, and temperature. Water samples were taken so that relevant cations and anions could be measured in the laboratory. The analytical results were both assessed by considering the raw data and modelled using the United States Geological Survey program PHREEQ. Saturation indices for relevant iron species were determined and it was found that the lake waters during the recent study were consistently supersaturated with respect to iron minerals. Additionally, it was also found that the micro-organisms had apparently altered local supersaturation conditions. Thus, this indicates that they were not merely bystanders in an inorganic mineralization process.

We also concluded that the iron bacteria had an absolute requirement for iron (II) sourced by the breakdown of pyrites in limestone and shales. A model explaining the uniform diameter of the *Leptothrix* sheaths, showed that the bacteria bound iron (II). Subsequently through metabolic processes, the iron(II) was oxidised to iron (III) where it precipitated on the sheaths as ferrihydrite. This was the first model to explain the nature of bio-minerals formed by the *Leptothrix* bacteria. This iron bio-mineral is biologically induced by precipitating onto the sheaths and stalks of the organisms through active mineralization processes.

The banded sediments near the lake are formed in a definite sequence of layers in a variety of colors. Grey bands were identified as silt, sands, and/or clays, the white as calcite, the black bands were anoxic and composed of iron sulfides and/or organic matter, and the red bands were largely iron (III) oxy-hydroxides. The sharp laterally continuous bands

in the sediments showed that they were likely deposited in a permanent pool of water. The composition of the bands and their location adjacent to the bacterial mat in the lake led to the investigation of the red bands for evidence of bio-minerals. The bands were found to contain broken large sheaths, characteristic of *Leptothrix*, thus establishing a potential link between the red bands and the bacterial mat.

The iron bacteria in the lake in the final chamber appear to thrive when the cave atmosphere is low in oxygen and high in carbon dioxide when the cave waters have reduced dissolved oxygen and become acidic. Heavy rain causes floods, during which organic matter, silt, sand, and clay are washed into the cave and deposited on top of the bacterial mat in the lake preserving it as a red band. The floods also probably flush the carbon dioxide from the cave atmosphere and increase dissolved oxygen and pH in the lake. After floods, these parameters slowly change. When the atmospheric carbon dioxide becomes sufficiently high, with the accompanying reduction in dissolved oxygen and acidity in the cave waters, the bacterial mat starts to grow again. The organic matter washed into the cave during floods is used by aerobic micro-organisms to create the above conditions. It has been shown that atmospheric carbon dioxide levels build up during periods of low rainfall. With long periods of low rainfall (drought), the lake becomes more anoxic and the iron (III) bacterial mat ceases to grow and anaerobic bacteria become active producing sulfides. These observations on the bacterial mat and the deposition of clastic sediments in lake have enabled a model to be prepared for the flood/drought history in the Bungonia area.

Early ^{14}C dating studies of the black charcoal bands showed that the banded sediments had been deposited in chronological order. The red bands contain less carbon but the amount was sufficient for dating by Accelerator Mass Spectroscopy ^{14}C techniques. Dating the red bands would have allowed the time of their deposition to be added to the flood/drought history model, however it was found

that dates of descending red layers were not chronological as in the previous studies. This suggests a reworking of the sediments during the 30 years of exposure. The banding of the layers is preserved visibly; this must be a chemical reworking. If this is so, dating of charcoal either from bands in close proximity to the red bands may give chronologically consistent results. Alternatively, better results may be obtained by dating sediments from below the current water level in the lake.

The bacterial mat and the red sediment bands contain magnetic material; this is taken as possible evidence for magnetotactic bacteria in Odyssey cave. These bacteria are common in aquatic habitats and are most abundant at the oxic-anoxic boundary such as are found in the lake in the final chamber. While further work is needed to confirm the presence of these bacteria, it has exciting implications for paleomagnetic studies in speleothems and cave sediments.

References

- CONTOS, A.K., (1998) Biomineralisation in caves. PhD Thesis, The University of Sydney, New South Wales, Australia.
- JAMES J.M., (1973) Sediments in a Bungonia Cave (B24). *International Speleology 1973, Proc. 6th International Speleological Congress*, vol.3, pp 449–456.
- JAMES, J.M., (1975) Cold water mineralisation processes in an Australian cave. *Transactions of the British Cave Research Association*, vol.2, pp 141–150.
- JAMES J.M., (1977) Carbon dioxide in the cave atmosphere. *Transactions of the British Cave Research Association*, Vol.4, pp 417–429
- JAMES J.M., A.J. PAVEY, and A.F. ROGERS (1975) Foul air and resulting hazards to cavers. *Transactions of the British Cave Research Association*, vol.2, pp 79–88.

EVIDENCE OF AMMONIA OXIDIZING ARCHAEAL COMMUNITY IN THE GRUTA DA CARIDADE, RIO GRANDE DO NORTE STATE, BRAZIL.

MARCELO AUGUSTO DE FREITAS KRAMER¹, LUCYMARA FASSARELA AGNEZ-LIMA²

¹Laboratório de Biologia Molecular e Genômica,DBG,CB,UFRN-Natal-RN-Brazi, molecularcave@yahoo.com.br

²Laboratório de Biologia Molecular e Genômica,DBG,CB,UFRN-Natal-RN-Brazil, lfagnez@ufrnet.br

Extended Abstract

The geomicrobiology of caves is an interdisciplinary field that is gaining in prominence around the world. As one of the main targets of geomicrobiology, the Archaea Domain represents a considerable fraction of the prokaryotic world in marine and terrestrial ecosystems, as well as in caves. To date, no research projects with a specific focus on this Domain have been done in Brazilian caves. The Rio Grande do Norte State (RN) has more than 300 of the almost 7000 caves that are well-known in Brazil. The objective of this study was to analyze the phylogenetic composition of the archaeal community in the soil of a cave (Gruta da Caridade, RN) located in a semiarid ecosystem. The study employed environmental genomic techniques (metagenomics).

Archaea are now known to be metabolically diverse organisms coexisting with Bacteria and Eukarya in a majority of environments (Gribaldo et al., 2006). The objective of this study was to analyze the composition of an Archaeal community in the sediments of the cave Gruta da Caridade (GC) using a culture-independent molecular approach. Located in Serra da Cruz, Rio Grande do Norte State (RN) in the northeast region of Brazil, GC is present in a marble formation which is probably between 600 to 570 Ma in age (Nascimento et al., 2007). The cave contains a stream along its entire length, which emanates from a spring. Also, inside the cave lives a large biodiversity of macrofauna, with frogs, bats, snakes and many kinds of invertebrate species. A sediment sample was collected from the cave and DNA extraction was performed. PCR was carried out using archaeal-specific 16S rRNA primers and PCR products were ligated in a plasmid vector. A total of 70 16S clones were sequenced. The sequences were compared via BLAST in the NCBI database. The majority of the phylotypes matched with uncultivated crenarchaeota species. However, one phylotype matched a single cultivated archaea with sequence fragments displaying 95–98% identity to the archaea Candidatus *Nitrososphaera gargensis*, an ammonia-oxidizing archaea (AOA) recently described as one of the few cultivated archaea known to be involved with the nitrogen cycle (Hatzenpichler et al., 2008). The source of the ammonia supporting the growth of these species remains to be elucidated, however the autotrophic AOA activity

potentially puts this archaea at the base of the food chain in this ecosystem. Currently, the GC cave is at risk because of iron mining in the area (Netto, 2008). These preliminary results should provide data to help preserve this rare cave system in the Rio Grande do Norte State, and shed the first light on Brazilian cave geomicrobiology.

A subsurface (2–5cm) sediment sample was collected from the cave. Total DNA was isolated from the cave sediment sample (0.5g) one day after the collection using the FastDNA spin kit for soil (Qbiogene, Inc.) or the PowerMax Soil DNA Isolation Kit (MO BIO Laboratories, Carlsbad, CA, USA) following the manufacturer's instructions. Partial 16S rRNA genes for *Archaea* were amplified from DNA extracts using the primers 20F and 958R (DeLong, 1992). PCR products were ligated into the pGEN-T vector. Seventy transformants were used to create a clone library from this environment.

Sequencing of PCR products was performed on MegaBace 1000 capillary sequencers (DNA Analysis System) using the primers T7 and SP6. The sequences obtained were compared against the NCBI and Ribosomal Database Project using the alignment BLAST tool.

Most of the 70 phylotypes isolated had similarity (> 90% nucleotide sequence identity) with uncultured Archaea and Crenarchaeota from different environments. The BLAST analysis results determined that one clone sequence, C103D05Ar1, had 97% similarity to the Candidatus *Nitrososphaera gargensis* 16S SSU rRNA gene sequence, a member of the Crenarchaeotal Group I.

Nitrification is the biological oxidation of ammonia (NH_3) to nitrate (NO_3^-) and an essential step in the global nitrogen cycle. The element nitrogen (N) is an essential nutrient for all organisms, and as a critical component of proteins, N is fundamental to the structures and biochemical processes that defines life. N is of such centrality that it has been suggested to be perhaps the best bio-signature for life on others planets (Capone et al. 2006). The identification of novel groups of Archaea in marine and terrestrial

environments indicates that Archaea are more diverse and widespread than previously thought (Adair et al. 2008; Francis et al. 2007; Bintrim et al. 1997). Analysis of the Archaeal phylotype library from the sediment of the Gruta da Caridade demonstrated the presence of a relative, Candidatus *Nitrososphaera gargensis* in a cave habitat. This presents the first evidence for ammonia oxidizing Archaea and the first member of the Crenarchaeotal Group I.1b in Brazilian caves. The GC sediment is rich in bat guano, which may be an ammonia source for an ammonia-oxidizing archaea community. In addition, the role played by an AOA community in the cave ecosystem might be essential to sustain some aquatic and terrestrial life in this environment, however, this remains to be further elucidated. Despite this, the present study provides the first insight into Brazilian cave geomicrobiology. Further studies must be developed to understand the diversity and activity of microbial communities in such cave ecosystem.

References

- ADAIR K. L. and E. SCHWARTZ (2008) Evidence that Ammonia-Oxidizing Archaea are More Abundant than Ammonia-Oxidizing Bacteria in Semiarid Soils of Northern Arizona, USA. *Microb Ecol* **56**, 420–426.
- BINTRIM S.B., T.J. DONOHUE, J. HANDELSMAN, G.P.ROBERTS, and R.M. GOODMAN (1997) Molecular phylogeny of Archaea from soil. *PNAS* **94**, 277–282.
- CAPONE D.G., R. POPA, B. FLOOD, K.H. NEALSON (2006) Follow the Nitrogen. *Science* **312**, 708–709.
- CAVICCHIOLI R., M.Z. DEMAERE, and T. THOMAS (2006) Metagenomic studies reveal the critical and wide-ranging ecological importance of uncultivated archaea: the role of ammonia oxidizers. *BioEssays* **29**, pp 11–14.
- DELONG E.F. (1992) Archaea in coastal marine environments. *Proc Natl Acad Sci USA* **89**, 5685–5689.
- FRANCIS C.A., J.M. BEMAN, and M.M. KUYPERS (2007) New processes and players in the nitrogen cycle: the microbial ecology of anaerobic and archaeal ammonia oxidizing. *The ISME Journal* **1**, 19–27.
- GRIBALDO S. and C. BROCHIER-ARMANET (2006) The origin and evolution of Archaea: a state of the art. *Phil. Trans. R. Soc. B* **361**, 1007–1022.
- HATZENPICHLER R., E.V. LEBEDEVA, E. SPIECK, K. STOECKER, A. RICHTER, H. DAIMS, and M. WAGNER (2008) A moderately thermophilic ammonia-oxidizing crenarchaeote from a hot spring. *PNAS* **105**, No. 6, pp 2134–2139.
- NASCIMENTO R.S.C., A.N. SIAL, and M.M. PIMENTEL (2007) C- and Sr-isotope systematics applied to Neoproterozoic marbles of the Seridó belt, northeastern Brazil. *Chemical Geology* **237**, 191–210.
- NETTO A.S. (2008) Da Ganância e do Prenúncio do Fim. *Lajedos* **1**, No. 2, pp 18–22.

DISCOVERING NEW DIVERSITY IN HAWAIIAN LAVA TUBE MICROBIAL MATS

MATTHEW G. GARCIA¹, MONICA MOYA¹, MICHAEL N. SPILDE², FRED D. STONE³, DIANA E. NORTHUP¹

¹Department of Biology, MSC03 2020, University of New Mexico, Albuquerque, NM 87131

²Institute of Meteoritics, MSC03 2050, University of New Mexico, Albuquerque, NM 87131

³University of Hawai'i at Hilo, Hilo, HI 96720 and Bishop Museum, Honolulu, HI

Bacterial mats cover walls and ceilings of lava tubes around the world, yet little is known about their composition and role in the ecosystem or what controls their diversity. To address these issues, we ask: (1) What bacterial species are found in the mats? (2) Does diversity vary with respect to the different ages of lava flow? (3) Does species composition differ between differently colored mats? and, (4) What is the amount of organic carbon present in the drip water entering the cave system that can fuel heterotrophic growth?

Rock samples were collected from microbial mats in six different lava tubes found on the Big Island of Hawai'i. Sampled mats ranged in color and included yellow, white, pink, blue-green, and an organic butterscotch ooze. Samples were aseptically collected from each cave, and DNA was extracted and then purified. The 16S rRNA gene was amplified using polymerase chain reaction (PCR) (~1365 bp), cloned, and then later sequenced. From this, closest relatives were found using the Ribosomal Database Project II and BLAST databases, and a parsimony phylogenetic tree was constructed using PAUP. *Actinobacteria* occurred in five of the six lava tubes sampled and were found to dominate where they occurred. *Acidobacteria* and *Proteobacteria* occurred in all six lava tubes, but which proteobacterial subdivisions were present varied. *Nitrospirae* occurred in four of the six lava tubes sampled. Other closest relatives were found to be *Cyanobacteria*, *Firmicutes* OP11, *Chloroflexi*, *Verrucomicrobia*, *Gemmatimonadetes*, *Planctomycetes*, *Bacteroidetes/Chlorobi* Group, and *Deinococcus-Thermus*.

The different types of morphology we find in these bacterial mats were visualized with a JEOL 5800 scanning electron microscope (SEM) equipped with an energy dispersive x-ray analyzer (EDX). These analyses showed diverse morphologies including some that are similar to *Actinobacteria*. Samples of drip water were collected in the caves that had constant drips from the ceiling for dissolved organic carbon (DOC) analysis using a Shimadzu TOC-5050A Total Organic Carbon Analyzer. DOC values ranged from 4.85 mg/L to 36.95 mg/L; level of DOC did not correspond to level of rainfall or vegetation.

Our studies show a great deal of novel diversity and several of the closest relatives of our sequences come from other cave studies. Overall, the diversity in our Hawaiian lava tube samples spans thirteen phyla of *Bacteria*, revealing a very diverse community in these striking mats.

1. Introduction

Worldwide lava tubes exhibit stunning microbial mats that cover the walls and ceilings with remarkable colors, and patterns. Even though these mats are commonly found in lava tubes, very little is known about them and they have received even less attention than microorganisms in limestone caves (Northup and Welbourn, 1997; Northup et al., 2008). Culture-dependent techniques have been the only methods applied in studying these mats, nicknamed "lava wall slime." Howarth (1981) suggested that slimes are important sites of nutrient recycling (e.g. nitrogen). Ashmole et al. (1992) found slimes present in humid

caves in the Canary and Azores Islands, but never in dry caves. Studies done in lava tubes in Washington, USA, have found slime consisting of different species of bacteria, including actinomycetes in the genus *Streptomyces* (Staley and Crawford, 1975). Researchers have since assumed that microbial mats in lava tubes are primarily composed of actinomycetes. Certain types of actinomycetes are medicinally and culturally significant because they excrete antibiotic products to repel invaders (Lazzarini et al., 2000). Antibiotic properties of many bacterial species make them interesting to the medicinal industry, providing a rationale for studying these microbial mats in lava tubes.

Our preliminary studies of a white and a yellow microbial mat in one lava tube in New Mexico, USA, revealed a more diverse microbial community than expected, which included *Actinobacteria*, *Chloroflexi*, *Verrucomicrobia*, *Acidobacteria*, and *Betaproteobacteria*. The greater diversity led us to expand our studies of lava tube microbial mats to investigate the species composition of microbial mats of different colors and from different locations. We are studying mats from lava tubes on the Big Island of Hawai'i by applying culture-independent phylogenetic techniques to uncover the diversity in these mats. Organic carbon present in drip water, composition of rock, and precipitation are some of the abiotic factors being taken into account so that we may further understand what controls the diversity of these microbial communities.

2. Methods

At each site, entrance elevation, GPS coordinates, cave temperature and humidity were recorded using an IMC Digital Thermometer probe. Age of the lava flow and average area rainfall were researched and recorded for later comparison. Small samples of wall rock covered with bacterial mats were collected from the six Hawaiian Island caves under a National Park Service collecting permit or permission of land owners. Samples were covered with sucrose lysis buffer to preserve the DNA and transported to the lab where they were stored in a -80° C freezer until DNA extraction. Yellow, white, and pink microbial mats were sampled, along with a blue-green mineral deposit from six different caves across the Big Island of Hawai'i. On the west side of the island or the "dry" side, we sampled three caves. In the northwestern region samples were collected from Beall's lava tube, a privately owned cave. In the southwestern portion of the island we sampled from Maelstrom and Kula Kai lava tubes, part of the Kipuka Kanohina Cave Preserve (KKCP) founded by the Cave Conservancy of Hawai'i. Both lava tubes in the KKPC are found in the same flow of lava. For the eastern side, the "wet" side of the island we sampled three caves as well. In the central part on the eastern side we sampled Kaumana and Epperson's lava tube. Kaumana lava tube is in Hawai'i Volcanoes National Park and Epperson's lava tube is privately owned. The last site is Bird Park lava tube that is in the southeast part of the island.

DNA was extracted and purified using the MoBio PowerSoil™ DNA Isolation Kit using the manufacturer's protocol (MoBio, Carlsbad, CA). Extracted DNA was amplified with universal bacterial primers 46 forward (5'-GCYTAAYACATGCAAGTCG-3') and 1409 reverse (5'-GTGACGGGCRGTGTGTRCAA-3')(Vesbach, personal communication). Amplicons were cleaned and purified using the Qiagen PCR cleanup kit (Qiagen,

Germantown, Maryland) and were cloned using the TOPO TA Cloning kit (Invitrogen, Carlsbad, CA) and sent to Washington University Genome Sequencing Facility for sequencing of 96 clones per sample with primers M13F and M13R. Once received, sequences were edited Sequencher 4.8. (Gene Codes, Ann Arbor, Michigan). To check the orientation of our sequences and to convert from antisense to sense OrientationChecker (www.cardiff.ac.uk/biosi/research/biosoft/) was used. Chimeras were detected using the Mallard software (<http://www.bioinformatics-toolkit.org/Mallard/>). Rarefaction curves were generated using DOTUR (<http://schloss.micro.umass.edu/software/dotur.html>) to ascertain whether sequencing had detected a comprehensive set of community members (Schloss and Handelsman 2005). Sequences were then classified at the phylum level using RDP classifier (Maidak et al., 2001). Sequences were analyzed using BLAST to identify closest relatives (NCBI; Altschul et al., 1997). Initial alignment was completed with Greengenes (greengenes.lbl.gov/) and manually corrected using BioEdit (<http://www.mbio.ncsu.edu/BioEdit/bioedit.html>), guided by 16S primary and secondary structure considerations. Parsimony analysis was performed using PAUP (version 4.0b10, distributed by Sinauer; <http://paup.csit.fsu.edu/>) and bootstrap analyses were conducted on 1000 re-sampled datasets.

Samples of the lava tube wall rock covered with microbial colonies were examined on a JEOL 5800 scanning electron microscope (SEM) equipped with an Oxford (Link) Isis energy dispersive x-ray analyzer (EDX). Rock samples with adherent bacterial colonies were mounted directly on an SEM sample stub while in the cave and then coated by evaporation with Au-Pd in the lab prior to imaging.

3. Results and Discussion

Overall, sequences from the eight lava tubes sampled from Hawai'i fall into thirteen phyla: all divisions of the *Proteobacteria* (except zeta), *Actinobacteria*, *Acidobacteria*, *Chloroflexi*, *Cyanobacteria*, *Nitrospirae*, *Verrucomicrobia*, *Gemmatimonadetes*, *Planctomycetes*, *Bacteroidetes/Chlorobi* Group, *Deinococcus-Thermus*, *OP11*, and *Firmicutes*. Because of space constraints, we will highlight only two microbial mat communities: The yellow microbial mat sample is from Kula Kai lava tube and a blue/green microbial sample is from Maelstrom lava tube. These communities are the focus of this discussion, yellow because it is one of the most dominant colors found in these Hawaiian lava tubes and blue/green because of its rarity.

Closest relatives of clones from a yellow microbial mat in the Kula Kai Caverns resided in four phyla: *Actinobacteria*,

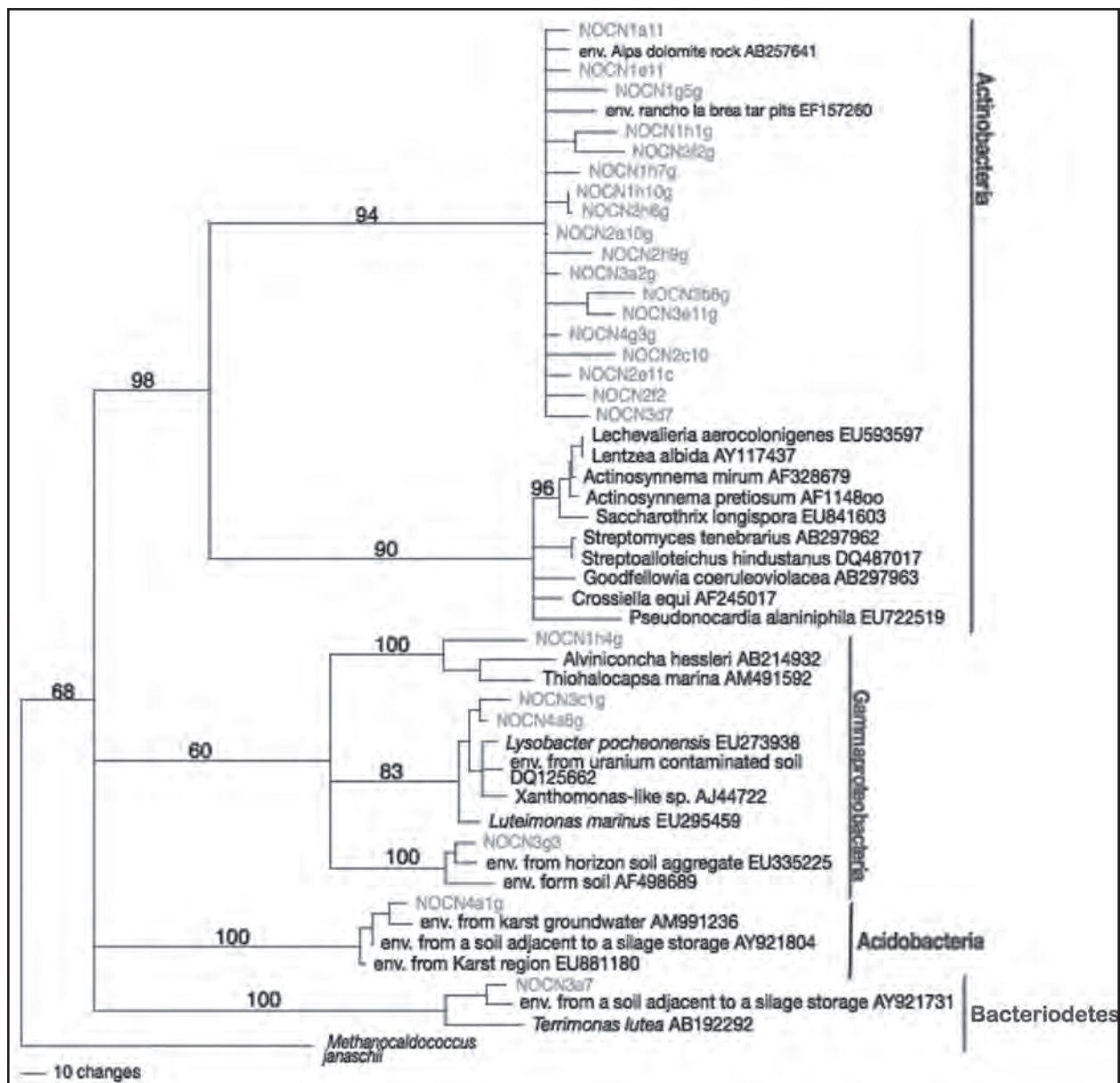

Figure 1: Parsimony tree of bacterial clone sequences from a yellow microbial mat from Kula Kai Caverns on the big island of Hawai'i. Numbers on the branches indicate bootstrap values from 1000 replicates and indicate the degree of support for relationships in this tree topology.

Gammaproteobacteria, Acidobacteria, and Bacteroidetes (Fig. 1). Kula Kai Actinobacteria clones had no close relatives and group with each other and two environmental, uncultured isolates; they did not group with the cultured relatives found in BLAST. This suggests that we may have novel species in our clone library. We found that the closest relatives to our clones were also environmental, which is common in some of our other studies. One of the most interesting relatives in this tree was *Thiohalocapsa marina*, a chemoautotroph in the Gammaproteobacteria that fixes CO₂. Other closest relatives in the Gammaproteobacteria, Acidobacteria, and Bacteroidetes (Fig. 1) were from uncultured soil isolates,

karst soils, and groundwater respectively.

The blue/green mineral deposits from Maelstrom lava tube contained nine phyla (Fig. 2), making it one of the most diverse communities we have sampled so far. This tree did not include any sequences from the Actinobacteria, one of the major phyla most commonly found in lava tube microbial mats. We found that many of the closest relatives to the sequences recovered from this sample were phylotypes found in other caves, such as Altamira Cave (Spain), Frasassi Cave (Italy), the Oregon cave system (USA), and a Hawaiian (USA) lava tube. Overall, our clones relate almost

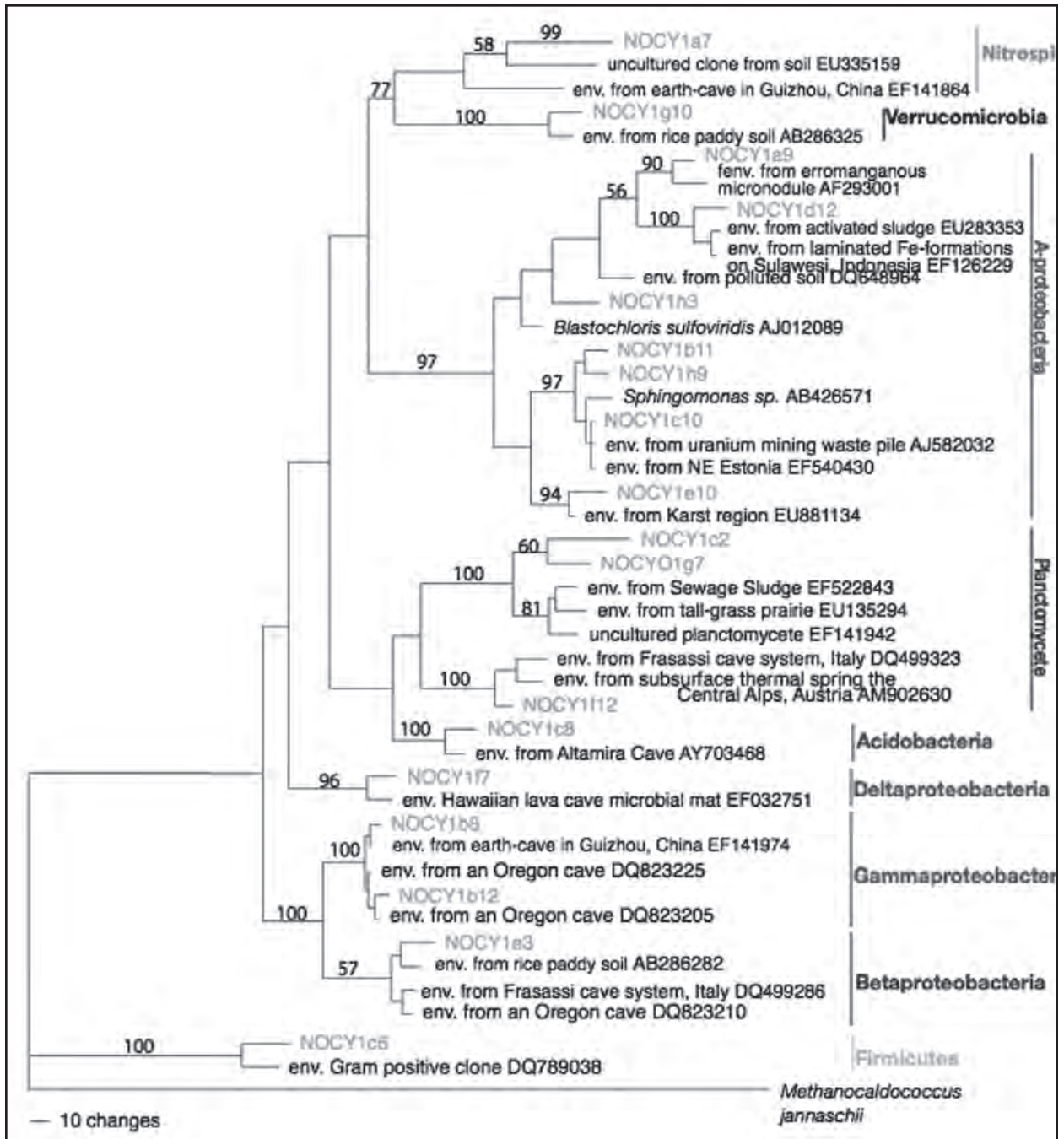

Figure 2: Parsimony tree of bacterial clone sequences from blue-green deposits in Maelstrom lava tube on the big island of Hawai'i. Numbers on the branches indicate bootstrap values from 1000 replicates and indicate the degree of support for relationships within this tree topology.

exclusively to environmental clones in soil, thermal springs, karst regions, and other cave systems.

Scanning electron microscopy (SEM) of Hawaiian lava tube microbial mat samples revealed an array of microbial morphologies. Fig. 3 shows an SEM photomicrograph of the blue/green mineral deposit with some striking features and a variety of morphologies. The SEM revealed a web of

filamentous-like structures across the sample, and clearly showed the presence of bacteria. At greater magnification, Figure 4 shows the morphology of the long filamentous structures that resemble reticulated filaments. We have found these reticulated filaments in other carbonate cave samples around the world (Melim et al., 2008). The EDX analysis of the blue/green mineral deposit suggested that this mineral is chrysocolla, a copper mineral.

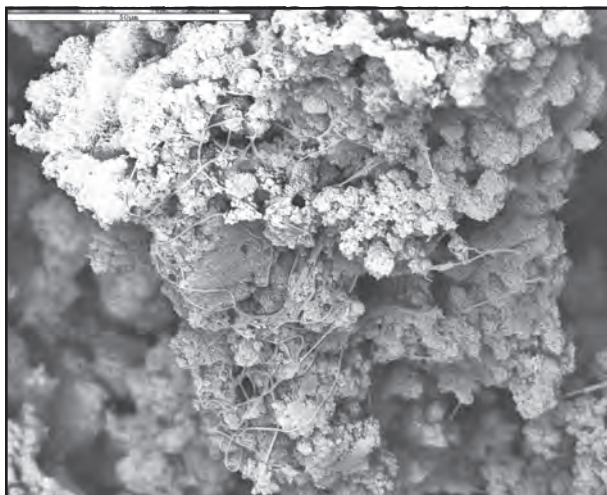

Figure 3: Scanning electron micrograph of blue-green mineral deposits from Maelstrom lava tube. Scale bar is 50 microns.

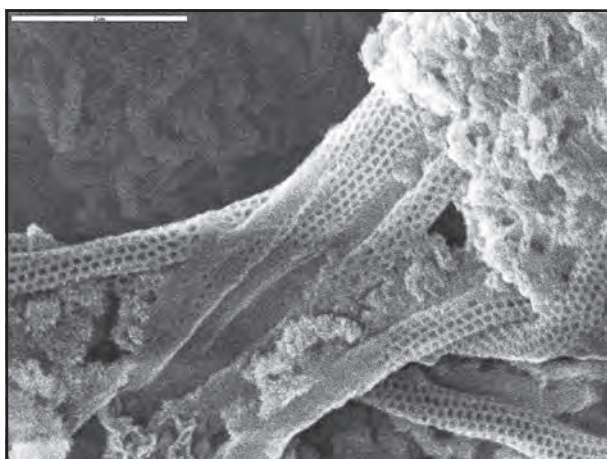

Figure 4: Close-up of filamentous structures in Figure 3 of blue-green mineral deposits from Maelstrom lava tube. Scale bar is 2 microns.

A qualitative examination of elevation, precipitation above the lava tube, age of the lava flow, and amount of organic carbon entering the cave in drip water (Table 2), did not reveal any significant trends as to what factors may affect microbial diversity in the mats. The greatest number of phyla were found in the mixed yellow/white mat samples from Bealls Cave and in the blue /green deposits from Maelstrom with 12 and 9 phyla respectively.

4. Conclusions

Our studies in Hawai'i to date reveal diversity that spans 13 phyla of *Bacteria*. The *Actinobacteria* are present in all samples that we have seen to date, except the blue/green mineral deposits, and substantial overlap is observed within the *Proteobacteria* with most of our samples. From our preliminary data we observe no trend between the amount of precipitation and amount of organic carbon present in

these cave systems. Also, there is no apparent trend between elevation or age of the lava flow and number of phyla with our current data, although there is a slight trend for older lava tubes to have more phyla present. DOTUR rarefaction curves indicate that more sequencing is needed for current clone libraries and analysis of additional samples will provide more insight into what controls species diversity in these microbial mats. Our preliminary results do indicate that the lava tube microbial mats are rich in diversity and contain a variety of microbial morphologies.

Acknowledgements

We would like to thank Dr. P. Boston, D. Medville, H. Medville, and D. Coons for assistance with field work and sampling. For permits and access to the lava tubes we thank the Cave Conservancy of Hawai'i, Hawaii Volcanoes National Park, and the landowners. J. Craig provided lab assistance for organic carbon analysis of the water samples. We thank Dr. B. Gannon and the UNO students for their comments on the manuscript. We thank K. Ingham for providing photographs of our sample sites. This work would not have been possible without the funding provided by the Cave Conservancy of the Virginias, Dr. J. Cook for the support of the UNO program, and the New Mexico Alliance for Minority Participation Program.

References

- Altschul S.F., T.L. Madden, A.A. Schäffer, J. Zhang, Z. Zhang, W. Miller, and D.J. Lipman, (1997) Gapped BLAST and PSI-BLAST: a new generation of protein database search programs. *Nucleic Acid Research* **25**, 3389–3402.
- Ashmole, N.P., P. Orom, M.J. Ashmole, and J.L. Martin. (1992) Primary faunal succession in volcanic terrain: Lava and cave studies on the Canary Islands. *Biological Journal of the Linnean Society* **46**, 207–234.
- Howarth, F.G. (1981) Community structure and niche differentiation in Hawaiian lava tubes. *Island Ecosystems: Biological Organization in Selected Hawaiian Communities* **15**, 318–336.
- Lazzarini, A., L. Cavaletti, G. Toppo, and F. Marinelli. (2000) Rare genera of actinomycetes as potential producers of new antibiotics. *Antonie van Leeuwenhoek International Journal of General and Molecular Microbiology* **78**, 99–405.

- Maidak, B.L., J.R. Cole, T.G. Lilburn, C.T. Parker Jr, P.R. Saxman, R.J. Farris, et al. (2001) The RDP-II (Ribosomal Database Project). *Nucleic Acids Research* **29**, 173–174.
- Melim, L.A., D.E. Northup, M.N. Spilde, B. Jones, P.J. Boston, and R.J. Bixby. (2008) Reticulated Filaments in Cave Pool Speleothems: Microbe or Mineral? *Journal of Cave and Karst Studies* **70**, 135–141.
- Northup, D.E., C.A. Connolly, A. Trent, V.M. Peck, M.N. Spilde, W.C. Welbourn, and D.O. Natvig. (2008) The Nature of bacterial communities in Four Windows Cave, El Malpais National Monument, New Mexico, USA. *AMCS Bulletin* **19**, 119–125.
- Northup, D.E. and W.C. Welbourn. (1997) Life in the twilight zone: Lava tube ecology. *New Mexico Bureau of Mines & Mineral Resources Bulletin* **156**, 69–82.
- Schloss, D.P. and J. Handelsman, (2005) Introducing DOTUR, a computer program for defining operational taxonomic units and estimating species richness: *Applied and Environmental Microbiology* **71**, 1501–1506.
- Staley, J.T., and R. Crawford, (1975) The biologist's chamber: lava tube slime. *Cascade Caver* **14**, 20–21.

AQUEOUS GEOCHEMICAL ENVIRONMENTS OF SISTEMA ZACATÓN, MÉXICO

MARCUS O. GARY^{1,2}, JASON SAHL³, PHILIP C. BENNETT², JOHN SPEAR³, JOHN M. SHARP, JR.²

¹Zara Environmental, LLC, Buda, Texas

²The University of Texas at Austin, Jackson School of Geosciences, Austin, Texas

³Colorado School of Mines, Environmental Science and Engineering, Golden, Colorado

Extended Abstract

Sistema Zacatón is an isolated hydrothermal karst area in Tamaulipas, Mexico, containing a series of water-filled sinkholes, or cenotes. Water chemistry is spatially variable from one cenote to the next, due in part to the geomorphic evolution of the karst and additionally by microbial processes taking place both in the water column and along the walls and floors of the cenotes. The deepest cenotes (Figure 1), including El Zacatón (319 m deep), have a highly homogeneous water chemistry due to convective mixing from hydrothermal water sourced from recently active local volcanism. El Zacatón and the adjacent cenote, Caracol, share similar geochemical processes dominated by the microbial cycling of sulfur and carbon, in a reducing,

anoxic environment throughout the entire water column. Microbial sulfide oxidation in these two cenotes results in visible suspensions of colloidal sulfur that develop diurnally, but only in the shallow photic zones, indicating activity from anoxygenic photosynthetic sulfur oxidizing bacteria. The cenote Verde is the only body of water to have discernable thermoclines, chemoclines, and seasonal variability, which indicate isolation from the deeper hydrothermal water feeding Zacatón and Caracol. The water is oxidizing, with dissolved oxygen values from 7 mg/L at the surface to 2 mg/l 45 m deep on the bottom. Verde does contain a hydrothermal spring on the northwest wall that feeds water with similar composition to that in the other cenotes, but at a

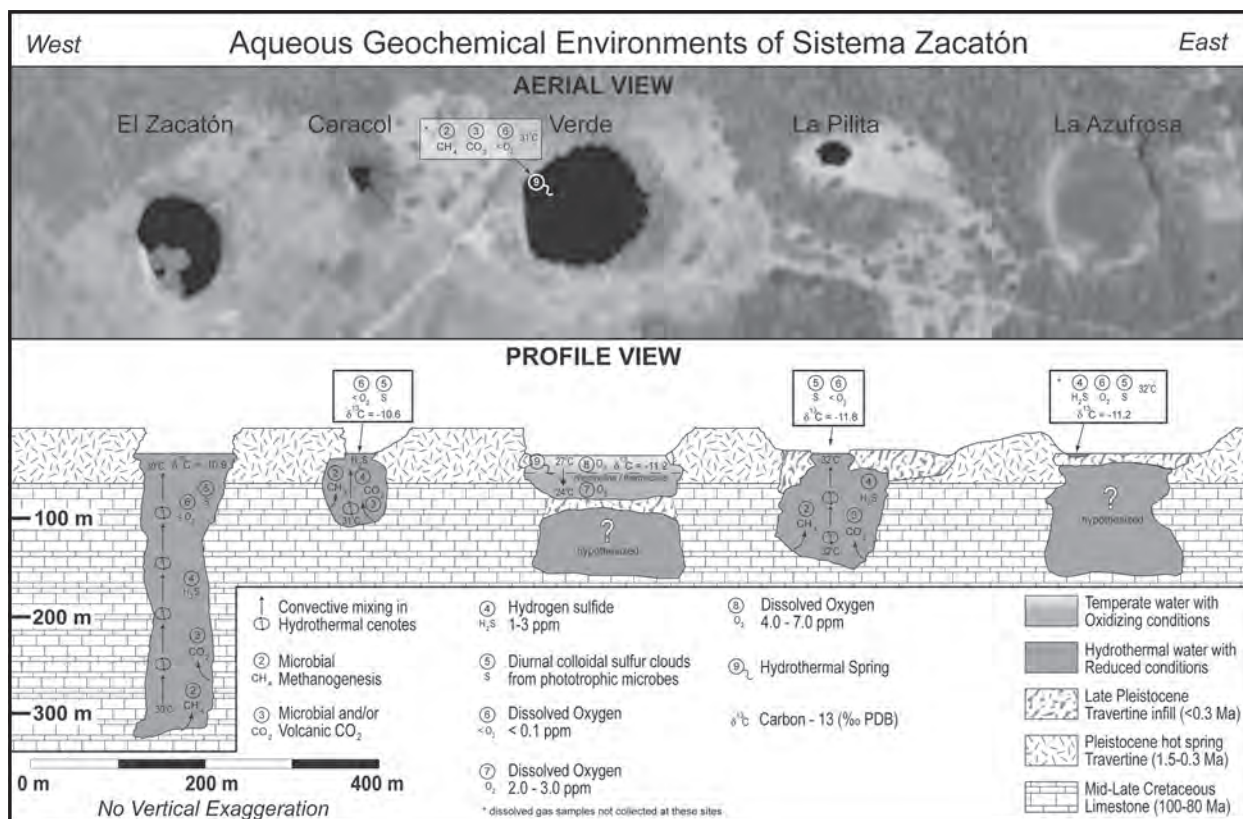

Figure 1: Aerial photograph and profile cross-section of the deep cenotes of Sistema Zacatón indicating major geochemical conditions observed. Physical geometry data for all features open to the surface has been collected using high-precision sonar sensors from the DEPTHX probe. Two hypothesized water bodies are thought to exist beneath Verde and Azufrosa based on geophysical data. If present, these isolated water bodies could contain unique microbial habitats.

very low flow rate relative to the large volume of water in the cenote. Just east of Verde, the cenote La Pilita shares similar geochemistry with Zacatón and Caracol; it is convectively mixed and has reducing, anoxic water. The four deepest cenotes (El Zacatón, Caracol, Verde, and La Pilita) all have geochemical signatures typical of a karst aquifer with Ca: HCO₃ type water, however all contain high concentrations of dissolved carbon dioxide and methane, likely a result of microbial activity. Carbon-13 isotopes from dissolved inorganic carbon at each of the four cenotes range from -10 ‰ to -12 ‰ PDB. These values likely reflect mixing between two sources of inorganic carbon: one from dissolution of source rocks at depth and the other from microbial cycling of carbon. Based on the presence of 16S rRNA gene sequences from known methanogens, the methane is most likely sourced from microbial methanogenesis.

Subtle changes in geochemistry are reflected in the microbiology, with distinct microbial communities in each of the cenotes. Clustering methods using 16S rRNA gene sequences amplified from a bulk DNA extraction of biomat material reveals that samples from each cenote cluster independently from samples from closely-situated cenotes with similar geochemistry. Due to the close proximity of cenotes with varied connectivity in the subsurface, small but statistically-significant differences in geochemistry most likely explain the observed differences in microbial community structure between cenotes. The geochemical environments observed at Sistema Zacatón result from both physical isolation of cenotes and microbial processes.

MICROBIAL COMMUNITY ENERGETICS IN RORAIMA SUR CAVE, VENEZUELA

J. GLARRIZZO¹, P. SUAREZ², B. MUENCH¹, M. BROERING¹, E. BANKS¹, K. VENKATESWARAN³, and H.A. BARTON¹

¹Department of Biological Sciences, Northern Kentucky University, Highland Heights, Ky USA

²Departamento de Biología de Organismos, Universidad Simón Bolívar, Caracas, Venezuela

³Biotechnology and Planetary Protection Group, California Institute of Technology, Jet Propulsion Laboratory, Pasadena, Calif USA

Extended Abstract

Roraima Tepui, located at the intersection of Venezuela, Guyana and Brazil, is an orthoquartzite massif consisting mostly of horizontal and gently dipping fluvial sandstones (quartz arenites) (Santos, 2003). Located within this massif is Roraima Sur Cave (RSC), the longest quartzite cave yet described (Galan *et al.*, 2005) at approximately 16 km in length. Similar cave systems are present in other tepuis, such as the Aonda Cave system in the Auyan-tepui (Piccini, 1995) and the Charles Brewer Cave in the Chimantá Tepui (Smida *et al.*, 2005, Aubrecht *et al.*, 2008). The annual rainfall at the top of the surrounding high mesas can reach 7,500 mm, which prevents soil formation and the establishment of nitrogen-fixing microbial communities. In the absence of nitrogen-fixing soils, the ecosystems on the tepuis are nitrogen starved to the point that many of the plants have adapted by becoming carnivorous. Due to the nitrogen limitation of Roraima Tepui it was anticipated that any microbial activity would be limited in the cave; however, during a reconnaissance trip in 2005, it was observed that a large amount of microbial activity was occurring in RSC.

To examine what activities were supporting the microbial community seen in RSC, an expedition returned in 2007. Samples of wall sediments for DNA extraction were collected from three different sites within the cave: Cricket Pool (CP), Red River (RR) and Lago Grande (LG). These sites were 30 m, 120 m and 500 m from the entrance, respectively. Temperature, humidity and pH were measured during sampling and the readings corresponded to depth into the system and passage location (Table 1). To obtain a rough estimate of microbial activity a luminescence based

ATPase assay was carried out (La Duc *et al.*, 2003). The amount of ATP, which correlates directly with cell number, demonstrated a much higher level of microbial activity in RSC than has been seen in others cave systems (Barton *et al.*, unpublished results), despite the remoteness and nutrient limitation of this environment.

Given the surprisingly high amount of microbial activity, an attempt was made to identify the drivers that were responsible for microbial ecosystem energetics in RSC. To do this, a molecular phylogenetic approach was used; genomic DNA was isolated from each site, the 16S small ribosomal subunit rRNA genes were PCR amplified and the PCR products were cloned to create a sequence based phylotype library.

Analysis of the phlotypes from CP demonstrated the presence of *Planctomycetales*, including members of the *Gemmata*, *Ostocoida* and *Isosphaera* genera, characterized by their capacity to carry out anaerobic ammonia oxidation (ANAMMOX). *Rhizobiales*-like bacteria were also present, including the methanotrophic genera *Methylocella*, *Methylosinus* and *Methylocystis*, and iron oxidizers from the genus *Rhodomyrobium*. The RR clone library also included methanotrophic species, such as *Methylocella* spp. and members of the genus *Nevskia*, which have the unusual property of being able to trap ammonia from the air (Sturmeyer *et al.*, 1998). The microbial community at LG demonstrated the presence of *Rhodopseudomonas* species, able to growth heterotrophically on complex organic substrates. However, of interest at the LG site

Site	pH	Temp room °C	Humidity	ATP (RLU)
Cricket Pool	7.0	11.8	98.2 %	4,025
Red River	7.1	11.6	99.6 %	15,352
Lago Grande	7.6	12.5	99.9%	8,933

Table 1: Values of measured parameters at different sampling sites.

was the dominance of a single bacterial species distantly related to the genera *Oscillochloris*. This group includes the photosynthetic, purple non sulfur bacteria. Nonetheless, given the aphotic nature of this environment and the dissimilarity of the phylotypes to previously cultivated representatives (85% similarity to full-length 16S rRNA gene sequence), this suggest that they may represent a previously undescribed bacterial lineage with unknown metabolic function. Within the bacterial clone libraries, we observed a significant population of both hydrogen and methane oxidizing bacteria, and large populations of nitrogen fixing bacteria. In addition, many of the sites contained a significant population of ammonia-, nitrite-, and nitrate-oxidizing species, together suggesting that an active nitrogen cycle is present at each site.

With methane oxidizers (methanotrophs) being such a prominent component of each sample site, this suggested that methane is an important substrate within the RSC environment, yet methane can only be produced by archaeal species. To examine the contribution of archaea in RSC we made an archaeal clone library at each site. Of the 400 archaeal phylotypes examined, all were all demonstrated similarity to either methanogenic or ammonia oxidizing *Crenarcheota*, suggesting that autotrophic methanogenesis may play an important role in ecosystem energetics. A potentially important contribution from ammonia oxidizing archaea (AOA) group has also been demonstrated, which seems to play an important role in the global nitrogen cycle (Hatzenpichler et al. 2008).

Given the role of hydrogen in archaeal methanogenesis and the numerous hydrogen oxidizing bacterial phylotypes observed, it appeared that hydrogen was an important component of microbial energy generation in RSC. Nonetheless, there were no obvious sources of hydrogen in RSC. If hydrogen is present, it should be possible to identify microbial species from the cave able to use hydrogen autotrophically as the primary energy source. To test this hypothesis, cultures were established in mineral media supplemented with a 5% CO₂/10% H₂ atmosphere. Over the course of several months, microbial growth was observed. Fluorescence *in situ* hybridization (FISH) analysis of this culture using fluorescently labeled DNA probes for bacteria (EUB338) and members of the *Epsilonproteobacteria* (EPSY549) confirmed the presence of these hydrogen oxidizing species, again suggesting the importance of hydrogen in this system.

Our results demonstrated that Roraima Sur Cave system contains a complex and rich microbial ecosystem.

Preliminary phylogenetic analyses in the cave suggest that autotrophic hydrogen and methane oxidation may be the primary drivers of ecosystem energetics, along with the autotrophic contributions of ammonia oxidizing species. These autotrophic reactions may then provide the energy necessary for nitrogen fixation, which in turn supports the nitrogen cycling activities of heterotrophic species. Given the high amounts of iron in the rock and the presence of radioisotopes in quartzites (Sengupta et al., 2005), it may be possible that geochemical activities such as serpentinization or radiolysis of water could be providing the necessary hydrogen. A return expedition is planned to determine geochemical mechanisms of hydrogen production and to further define the metabolic contribution of microbial species in this ecosystem.

Acknowledgement

This research was supported by sampling permits #I-111 and #3953 provided by The Venezuelan Environmental Ministry at the Vice Ministry of Environmental Management and Administration, Caracas, Venezuela.

References

- Santos, J.O.S., P.E Potter, N.J. Reis, L.A. Hartmann, I.R. Fletcher, and N.J. McNaughton, 2003. Age, source, and regional stratigraphy of the Roraima Supergroup and Roraima-like outliers in northern South America based on U-Pb geochronology: GSA Bulletin, vol 115, pp 331–8.
- Galan, C., F.Herrera, and R.Carreño, 2005. Roraima Sur Cave Venezuela, the longest quartzite caves in the world, Venez. Soc. Speol. Bull., March 2005.
- Hatzenpichler, R., E.V. Lebedeva, E.Spieck, K.Stoecker, A.Richter, H.Daims, and M. Wagner, 2008, A moderately thermophilic ammonia-oxidizing crenarchaeote from a hot spring: Proc Natl Acad Sci U S A, vol 105, pp 2134–9.
- Mecchia, M. and L. Piccini, 1999. Hydrogeology and SiO₂ Geochemistry of the Aonda Cave System (Auyan-Tepui, Bolivar, Venezuela): Bol. SVE vol 33, pp 1–18.
- Šmida, B., C.H. Brewer-Carias, and M. Audy, 2005. Cueva Charles Brewer—Najvačšia kvarcítova jaskyňa sveta [Cueva Charles Brewer—the largest quartzite cave in the World—in Slovak and Spanish]: Bull. SSS, vol 36, pp 1–178.

Senguptaa, D., A. Ghoshb, and M.A. Mamtani, 2005.
Radioactivity studies along fracture zones in areas
around Galudih, East Singhbhum, Jharkhand, India:
Appl. Rad. Isotopes, vol 63, pp 409–414.

Sturmeyer, H., J. Overmann, H.D. Babenzien, and H.
Cypionka, 1998, Ecophysiological and phylogenetic
studies of *Nevskia ramosa* in pure culture: Appl
Environ Microbiol, vol 64, pp 1890–4.

La Duc, M.T., R Kern, and K. Venkateswaran. 2003,
Microbial monitoring of spacecraft and associated
environments, Microbial Ecology, vol 47, pp 150–
158.

MICROBIAL ACTIVITY IN THE REMOVAL OF XENOBIOTIC COMPOUNDS FROM KARST AQUIFERS

B. IKER¹, B. LUBBERS¹, P. KAMBESIS², H.A. BARTON¹

¹Department of Biological Sciences, Northern Kentucky University, Highland Heights, KY, USA

²Hoffman Environmental Research Institute, Western Kentucky University, Bowling Green, KY, USA

Extended Abstract

Over 25% of the world's drinking water flows through karst aquifers, yet little is known about the role that microbial processes in these environments play in maintaining the quality and potability of this water [Hancock et al. 2008; Steele et al. 2008]. The entry of pollutants into groundwater is a particular problem in karst areas, where fast flow rates limit purifying reactions, such as adsorption, degradation and filtration [Bayless 2001; Capel et al. 2008; Ford and Williams 1989; Hancock et al. 2008; Martin-Neto et al. 2001; Steele et al. 2008; White 1988]. By using the pesticide atrazine (2-chloro-4-ethylamino-6-isopropylamino-*s*-triazine) as a model xenobiotic compound, we examined what role the geochemical interactions of microbial species might have on degrading these compounds in the Coldwater Cave drainage basin, Iowa. Atrazine is among the most widely used agricultural chemicals, despite the fact that it is known to function as an endocrine disruptor in fish, amphibians and reptiles [Hayes et al. 2002; Suzawa and Ingraham 2008]. In a past study, our results suggested that atrazine can have a profoundly negative impact on both water quality and microbial ecosystem energetics in karst groundwater systems. Consequences include the introduction of exogenous metabolic genes, the production of high levels of degradation products such as deethylatrazine and hydroxyatrazine, a shift in ammonia oxidizing activity and the accumulation of nitrate [Iker et al. 2009]. Given the shift in ecosystem energetics following the addition of atrazine, we wanted to examine how atrazine changed the microbial community structure in these environments and what species play a dominant role in the degradation of this xenobiotic compound.

To test the impacts of atrazine on microbial community structure, we collected samples from two locations within Coldwater Cave; an impacted site (IM) directly below a swallow bringing atrazine contaminated water into the cave, and a pristine area (PR) exposed to atrazine only during rare periods of high flow. Sediment samples were resuspended in filter-sterilized cave water and incubated in the dark for 3 weeks, either in the absence (IM and PR) or presence (P-IM and P-PR) of 100 µg/mL atrazine. A molecular

phylogenetic analysis of these samples pre- and post-atrazine enrichment was carried out by sequencing 16S rRNA gene clone libraries. Prior to atrazine addition, both the HI and NI sediments display a similar community structure to each other and to microbial communities we have observed in other caves [Barton and Jurado 2007; Barton et al. 2004; Barton et al. 2007]. Unifrac analysis confirmed that the HI and NI community profiles were statistically similar prior to atrazine enrichment.

Following the addition of atrazine, there was a significant shift in the community profiles of both samples. In the sample from the atrazine impacted environment (P-IM), the population demonstrated a significant increase in members of the *Betaproteobacteria*, *Chloroflexi* and *Planctomycete* divisions, with a loss of *Firmicutes* and *Gammaproteobacteria* populations. Within the P-IM community, members of the *Acidobacteria*, *Deltaproteobacteria*, *Chlamydiae* and *Gemmatimonadetes* predominated. Since these species were not dominant prior to the addition of atrazine, the results suggest that they play a role either in atrazine breakdown or altered ecosystem energetics. Within the non-impacted (P-PR) microcosm, there was an increase in the size of the *Planctomycete* population. *Planctomycetes* populations are the only bacterial division known to carry out anaerobic ammonia oxidation (ANAMMOX), and the potential enrichment of these species may suggest that this mechanism of energy acquisition may become more pronounced in the presence of atrazine. We also observed an increase in the *Gammaproteobacteria* population and, a dramatic decrease in the *Betaproteobacteria* population with the addition of atrazine, contrasting with the results obtained for the P-IM microcosm. It is intriguing to note that members of the *Firmicutes* and *Deltaproteobacteria* were only observed in the atrazine enriched P-PR sample, even though these species are commonly identified within cave environments. Together these data suggest a shift in population structure at each site, although these changes display no similarity. This lack of a commonality in community structure change was confirmed by Unifrac analysis, which confirmed that all similarities between the IM and PR communities were lost.

Microbes are thought to be well adapted for catabolizing xenobiotic compounds (Habe and Omori, 2003). We have long postulated that microbial communities in cave environments are capable of breaking down complex aromatic compounds via metabolic consortia (Barton and Jurado, 2007). Atrazine itself represents a weak carbon and energy source, with the aminoacyl groups of the compound representing partially oxidized substrates (the triazine ring itself is fully oxidized), but can provide large amounts of nitrogen into the system in the form ammonia. While large amounts of ammonia entering a nitrogen-limited environment will affect nutrient scavenging, it may also lead to a change in ecosystem energetics. This may be manifested with an increase in either ammonia oxidizing bacteria (AOB), anaerobic ammonia oxidation (ANAMMOX) and subsequent nitrite oxidizing bacteria (NOB) and denitrification.

Cave communities can be negatively impacted by too much energy introduced into a potentially fragile system (Barton et al., 2004). More easily obtained energy can divert microbes from their normal functions in these systems, slowing many geomicrobiological processes, such as the mineralization of nitrate. An *in silico* comparison (BLAST) of the phylotypes observed in the P-IM sediments to publically available databases (NCBI) [Altschul et al. 1997] demonstrated that many of the observed species were more commonly found in soils. Indeed, a functional gene analysis of the total sample population revealed that atrazine was being broken down rapidly ($t_{1/2} = 3$ days) at the IM site by surface-derived, atrazine degrading species [Iker et al. 2009]. In the PR microcosm, atrazine is being broken down much more slowly ($t_{1/2} = 21$ days). Many sequences within the P-PR library demonstrated the closest similarity to phylotypes previously identified in cave environments in geographically diverse locations in the United States (Mammoth Cave, KY, Carlsbad Caverns, NM, Orgeon Caves, OR and lava tubes in Hawaii) and elsewhere (Moville Cave, Romaina, and Frasissi Cave, Italy). The results show that microbial species in both geographically and geochemically diverse cave environments share a phylogenetic lineage, further suggesting that the geochemistry of cave environments has preserved the unique phylogenetic signature of cave species. Further, the results suggest that microbial species may act to break down chemically complex structures through the heterotrophic interactions important in carbon turnover under the nutrient-limited conditions of caves.

Studying the fate of atrazine in karst and aquifer systems will help us understand its ecological impacts on cave ecosystems, novel microbial metabolic pathways,

and possible bioremediation applications for cave derived species. In addition, it may demonstrate the critically important role that cave microorganisms play in maintaining safe drinking water. Given the large number (>200) industrial pollutants reported to impact groundwater, atrazine (which is easily identified through the use of convenient field assay equipment) may serve as a model for the fate and impact of other xenobiotic compounds in important groundwater systems.

References

- Altschul, S.F., T.L. Madden, A.J. Schaffer, J. Zhang, Z. Zhang, W. Miller, and D.J. Lipman, 1997, Gapped BLAST and PSI-BLAST: a new generation of protein database search programs.: *Nuc. Acids Res.*, vol 25, pp 3389–3402.
- Barton, H.A. and V. Jurado, 2007, What's Up Down There: Microbial Diversity in Starved Cave Environments.: *Microbe*, vol 2, pp 132–138.
- Barton, H.A., M.R. Taylor, and N.R. Pace, 2004, Molecular Phylogenetic Analysis of a Bacterial Community in an Oligotrophic Cave Environment.: *J. Geomicrobiology*, vol 21, pp 11–20.
- Barton, H.A., N.M. Taylor, M. Kreate, A.J. Springer, S.A. Oehrle, and J.L. Bertog, 2007, The Impact of Host Rock Geochemistry on Bacterial Community Structure in Oligotrophic Cave Environments.: *International Journal of Speleology*, vol 36, pp 93–104.
- Bayless, E.R., 2001, Atrazine retention and degradation in the vadoze zone at a till plain site in central Indiana.: *Ground Water*, vol 39, pp 169–180.
- Capel, P.D., K.A. McCarthy, and J.E. Barbash, 2008, National, holistic, watershed-scale approach to understand the sources, transport, and fate of agricultural chemicals: *J Environ Qual*, vol 37, pp 983–993.
- Ford, D. and P. Williams, 1989, *Karst Geomorphology and Hydrology*.: New York, NY, Harper Collins Publishers, Ltd., 608 pp.
- Hancock, T.C., M.W. Sandstrom, J.R. Vogel, R.M. Webb, E.R. Bayless, and J.E. Barbash, 2008, Pesticide fate and transport throughout unsaturated zones in five agricultural settings, USA: *J Environ Qual*, vol 37, pp 1086–1100.

- Hayes, T.B., A. Collins, M. Lee, M. Mendoza, N. Noriega, A.A. Stuart, and A. Vonk, 2002, Hermaphroditic, demasculinized frogs after exposure to the herbicide atrazine at low ecologically relevant doses: *Proc Natl Acad Sci U S A*, vol 99, pp 5476–80.
- Iker, B.C., P. Kambesis, C. Groves, and H.A. Barton, 2009, Microbial atrazine breakdown in a karst groundwater system and its effects on ecosystem energetics.: *J Environ Qual*, vol Submitted.
- Martin-Neto, L., D.G. Traghetta, C.M.P. Vaz, S. Crestana, and G. Sposito, 2001, On the Interaction Mechanisms of Atrazine and Hydroxyatrazine with Humic Substances.: *Journal of Environmental Quality*, vol 30, pp 520–525.
- Steele, G.V., H.M. Johnson, M.W. Sandstrom, P.D. Capel, and J.E. Barbash, 2008, Occurrence and fate of pesticides in four contrasting agricultural settings in the United States: *J Environ Qual*, vol 37, pp 1116–32.
- Suzawa, M. and H.A. Ingraham, 2008, The herbicide atrazine activates endocrine gene networks via non-steroidal NR5A nuclear receptors in fish and mammalian cells: *PLoS ONE*, vol 3, p 2117.
- White, W.B., 1988, *Geomorphology and Hydrology of Karst Terrains.*: New York, NY, Oxford University Press, 464 pp.

MICROBIALLY INDUCED CALCITIC MOONMILK DEPOSITS LEAD TO INHIBITION OF MICROBIAL ACTIVITY IN CAVES

I. JANICES¹, M.C. PORTILLO², S. CUEZVA¹, J.M. GONZALEZ², J.C. CAÑAVERAS³, S. SANCHEZ-MORAL¹

¹ National Museum of Natural Sciences, MNCN-CSIC, Jose Gutierrez Abascal 2, 28006 – Madrid, Spain

² IRNAS-CSIC, Avda. Reina Mercedes 10, 41012 - Seville, Spain

³ Laboratorio de Petrología Aplicada CSIC-UA, Universidad de Alicante, Spain

A decisive role for microorganisms in the formation of calcitic moonmilk deposits has been previously suggested. A model of stepwise formation of these deposits was based on morphological evidence of microbial colonization of rock surfaces followed by calcite deposition over the microbial communities, microstructural breakdown, and accumulation of collapsed fibers. Aiming to verify the proposed model, a combination of techniques such as microbial activity estimates, stable isotope analyses and petrographic examination were used to study the role of microbial communities on specific types of carbonate deposits. Results from this study complement the previous model suggesting that moonmilk consists of stacked layers of mineral deposits directly induced by microbial activity. However, these calcite-based deposits produce microbial growth inhibition leading to a progressive decay of microbial activity as the mineralization accumulates. These results are in agreement with former results reporting a progressive entombment of microorganisms, mainly bacteria, involved in the induction of carbonate crystal growth.

1. Introduction

Moonmilk is a soft, wet, fine-grained secondary cave deposit which has been suggested to be of microbial origin, either by biologically-induced or biologically-controlled mineralization (BARTON & NORTHUP, 2007). Based on morphology, a previous study (CAÑAVERAS et al., 2006) has established a model for the growth of subaerial moonmilk deposits in Altamira Cave, Spain. Moonmilk was understood as a carbonate deposit formed through microbial colonization of rock surfaces, followed by calcite deposition along bacterial surfaces, microstructural breakdown, and accumulation of collapsed fibers. In order to better understand moonmilk formation, we have employed a combination of geochemical and microbiological techniques including measurements of stable isotope fractionation, and microbial activity estimates. Microbial activity measurements were performed in situ. Two novel methods were adapted to this aim: nano respirometry based on oxygen consumption measurements according to NIELSEN et al. (2007) and fluorometric quantification of DNA, RNA, and proteins (PORTILLO and GONZALEZ, 2009).

2. Results and Discussion

Calcite moonmilk in Altamira Cave showed an internal structure with three layers: an upper/external layer composed of smooth monocrystalline rods in association with filamentous microorganisms; an intermediate layer mainly composed of serrated-edged rods and also related to the presence of filamentous microorganisms; and

a lower/inner layer composed of overgrown rods and polycrystals with abundant EPS and microbes with different morphologies (filaments, rods and coccoids).

The $\delta^{13}\text{C}$ values of moonmilk range from -10.5‰ to -14.2‰ throughout the studied cave. These values are isotopically lighter than most speleothems present in Altamira Cave galleries (mean $\delta^{13}\text{C} = -9.1\text{‰}$) and both types of speleothems are significantly lighter than the host rock ($\delta^{13}\text{C} = -1.3\text{‰}$) (Fig. 1). The microbially colonized clay-rich substrate showed values ($\delta^{13}\text{C} = -13.2\text{‰}$) within the range observed for moonmilk. The $\delta^{18}\text{O}$ values of moonmilk range from -9.2‰ to -4.8‰. These values are lighter than most speleothems in the cave. Specifically, the $\delta^{18}\text{O}$ values of active speleothems range from -4.7‰ to -4.0‰ which are just above the observed range for moonmilk. The $\delta^{18}\text{O}$ composition of calcite crystals in moonmilk was in the same range as both the microbial colonized clay-rich substrate (-6.1‰) and the host rock (-4.8‰) (Fig. 1).

Microbial activity determined from nano respirometry assays clearly showed low oxygen consumption in moonmilk samples while microbial oxygen consumption was much higher in the host rocks showing no carbonate deposits (Fig. 2). Results from Figure 3 suggest that the activity and biomass of the microorganisms (from RNA and protein content) decreased as the moonmilk deposits became thicker. This is indicated by the trend of the curves in this figure. This result implies that entrapment of microbes in carbonate deposits leads to their inactivation.

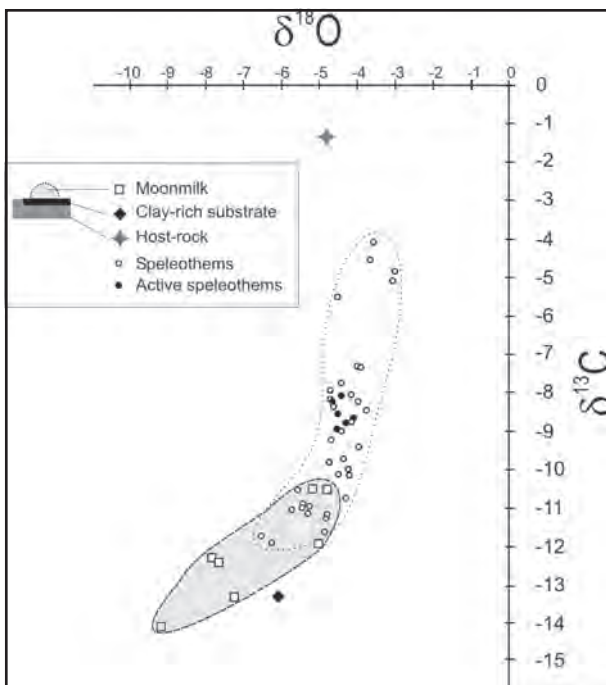

Figure 1: Plot of $\delta^{13}C - \delta^{18}O$ for calcitic moonmilk deposits and associated features of Altamira Cave.

The wide range of the $\delta^{18}O$ values from moonmilk do not suggest isotope equilibrium deposition in the calcite–water system. Likewise, low $\delta^{13}C$ values of moonmilk deposits could be related to a fractionation effect due to microbial activity (ROMANEK et al., 1992). Covariation between $\delta^{18}O$ and $\delta^{13}C$, probably also indicates that precipitation of calcite in moonmilk occurred under non-equilibrium conditions and was most probably influenced by microbial processes and specific microenvironments around the

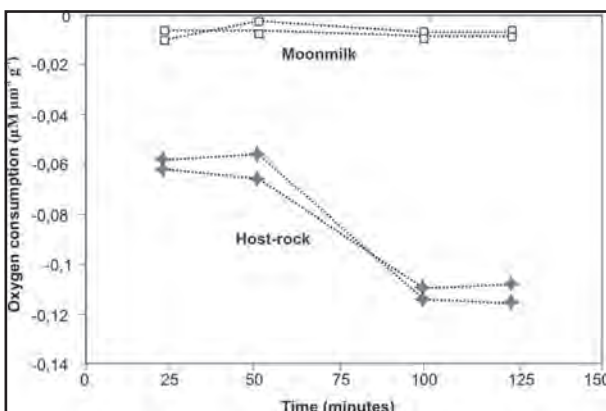

Figure 2: The decrease of oxygen concentration as microsensor tip approaches the sample was determined for moonmilk samples and host-rocks at four different incubation periods. The slope represents the consumption of oxygen by the sample with depth in a microchamber where oxygen diffuses in from the upper, open part while at the bottom the sample consumes the dissolved oxygen.

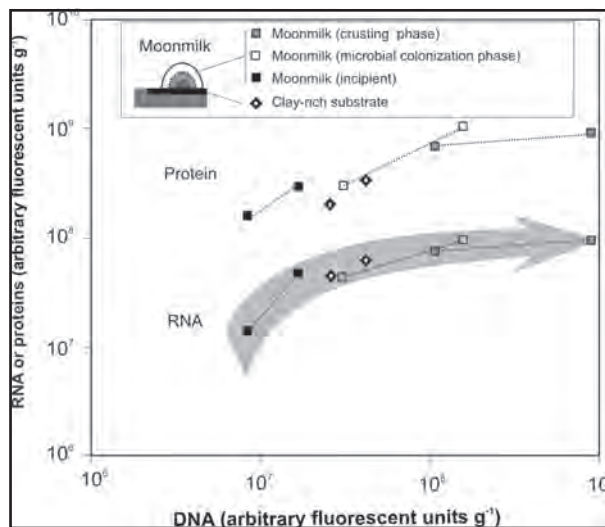

Figure 3: Relationships between RNA and Protein contents in different types of samples versus quantified DNA.

nucleation sites. Microbial activity might be influenced by the availability of nutrients for growth and clay-rich substrates might represent the major source of nutrients on cave walls. Thus, the observed similarity in the values of $\delta^{13}C$ for clay-rich substrate and moonmilk also supports the hypothesis of a direct role of microbial controlled mineralization in the formation of moonmilk deposits. Clay-rich substrate colonized by microorganisms represents a favourable medium for the development and proliferation of bacteria as suggested by oxygen consumption estimates obtained during this study. In the preliminary phase of microbial colonization, water pH increases around bacteria as a result of their metabolism. This change in pH leads to the formation of monocristalline rods which begin to precipitate (incipient moonmilk). At that moment, bacterial activity is at the highest levels and should be proportional to bacterial abundance and biomass as should be the case for balanced growth of bacteria (PORTILLO and GONZALEZ, 2009). As the accumulation of calcium carbonate progresses, the area covered by that deposition becomes unfavourable for most bacteria. Thus, in this intermediate phase of moonmilk formation, the relationships of bacterial abundance to metabolic activity or biomass tends to level-off indicating that bacterial activity and growth are decreasing as precipitation progresses. At the advanced stages of moonmilk formation, bacterial activity remains high on the rock substrata around the precipitate, which leads to further expansion of the deposits. Inside the moonmilk deposits, a number of bacteria will be entombed within the crystalline network which is suggested by relatively high levels of DNA deposited while low metabolic activity (determined from oxygen consumption and RNA content) and biomass in a per cell basis were observed.

Acknowledgments

This research was supported by CGL2006-11561/BTE project. All Altamira Cave Research Centre and Museum staff are acknowledged for their collaboration throughout the whole research period.

References

BARTON, H.A. and D.E.NORTHUP (2007).
 Geomicrobiology in cave environments: past, current and future perspectives. *Journal of Cave and Karst Studies* 69(1): 163–178.

CAÑAVÉRAS J.C., S. CUEZVA, S. SANCHEZ-MORAL, J. LARIO, L. LAIZ, J.M. GONZALEZ, and C. SAIZ-JIMENEZ (2006). On the origin of fiber calcite crystals in moonmilk deposits. *Naturwissenschaften* 93: 27–32.

NIELSEN, P., L.H. LARSEN, H. RAMLOV, and B.W. HANSEN (2007). Respiration rates of subitaneous eggs from a marine calanoid copepod: monitored by nanorespirometry. *Journal of Comparative Physiology B* 177: 287–296.

PORTILLO, M.C. and J.M. GONZALEZ, (2009). Fluorescent measurements of DNA, RNA, and proteins to perform comparative analyses of microbial communities from the environment. *Journal of Rapid Methods and Automation in Microbiology* (in press).

ROMANEK, C.S., E.L. GROSSMAN, and J.W. MORSE (1992). Carbon isotopic fractionation in synthetic aragonite and calcite: Effects of temperature and precipitation rate. *Geochim. Cosmochim. Acta* 56: 419–430.

BIODIVERSITY AND BIOGEOGRAPHY OF EXTREMELY ACIDIC SULFIDIC CAVE SNOTTITES

D.S. JONES and J.L. MACALADY

The Pennsylvania State University, Geosciences, 224 Deike Building, University Park PA 16802 USA

Extended Abstract

“Snottites” are extremely acidic (pH 0-1) biofilms found in sulfide-rich caves. We used a combination of culture-dependent and culture-independent analyses to investigate the community and population ecology of snottites from sulfidic caves in Italy and Mexico. The goal of the research presented here was to determine the composition and structure of snottite microbial communities, and to compare snottites within and among widely separated cave systems. We used a combination of 16S rDNA cloning and fluorescence *in situ* hybridization (FISH) to quantify and compare the microbial communities of different snottite samples. Then, to determine evolutionary relationships among physically separated populations of snottite microorganisms, we isolated *Acidithiobacillus* strains from different snottite samples and measured genetic distances among them via 16S rRNA gene and 16S-23S intergenic transcribed spacer (ITS) sequence analysis.

In 2007 and 2008, we collected snottite samples from Cueva de Villa Luz and Cueva de Luna Azufre in Tabasco, Mexico, and from le Grotte di Frasassi and Grotta Nuova del Rio Garaffo in central Italy. At least two sampling sites were chosen in each cave system. Samples for 16S rDNA cloning and FISH were collected as described previously (Macalady et al., 2007). Samples for culturing were stored at 4°C until inoculation and enriched for *Acidithiobacillus* sp. using autotrophic thiosulfate media. *Acidithiobacillus* strains were isolated by streak-planting. Cloning was performed using bacterial-specific forward primer 27f and universal reverse primer 1492r (Macalady et al., 2007). Additional clones were obtained by pairing 1492r with universal and archaeal-specific forward primers. Complete 16S rDNA and ITS regions from *Acidithiobacillus* isolates were amplified and sequenced using 27f coupled with reverse primer 2 from Sagredo et al. (1992). Maximum parsimony (heuristic search, 2000 bootstrap replicates) and neighbor joining (2000 bootstrap replicates) analyses were conducted in PAUP* version 4.0b10 (Swofford, 2000). Rarefaction analyses were performed in R version 2.5.1 using the ‘rarefy’ function available with the vegan package (Oksanen et al., 2008).

Five snottite samples were surveyed using 16S rDNA

cloning. All samples had very low biodiversity. The most diverse sample contained two archaeal and eight bacterial phylotypes, and the least diverse samples contained a single bacterial phylotype. Figure 1 shows rarefaction curves for the five bacterial clone libraries. Fluorescence *in situ* hybridization (FISH) of snottites from over 12 cave locations confirmed that all samples have very low biodiversity and are dominated by *Acidithiobacillus* species. Archaea of the Thermoplasmatales group range in abundance from 0 to 50% of total cells, and smaller populations of *Acidimicrobium* species make up as much as 15% of total cells. Other bacteria present in clone libraries include members of the genus *Sulfobacillus*, TM6, and TM7 lineages. These rare phylotypes account for less than 5% of total cells. Filamentous fungi and protists are present in most snottite samples, and snottites from Villa Luz and Luna Azufre even contain microinvertebrates such as mites and nematodes.

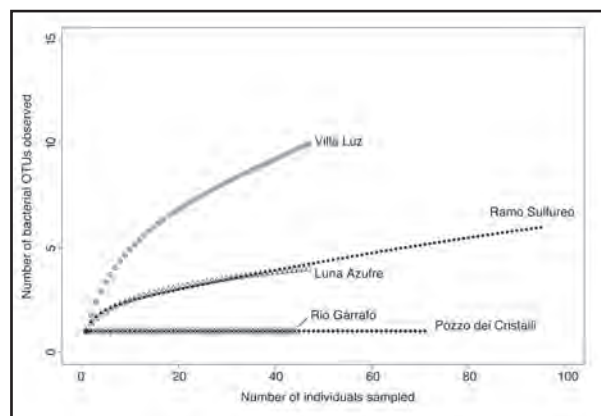

Figure 1: Rarefaction curves for 16S rDNA bacterial clone libraries from five snottite samples. Operational taxonomic units (OTU's) are defined by 98% sequence similarity.

Although the same taxa often recur in different snottite samples, snottite community composition is quite variable overall (Fig. 1). The only taxon found in all snottites sampled to date is *Acidithiobacillus*, which always makes up greater than 50% of cells. This finding suggests that *Acidithiobacillus* spp. are keystone members of the snottite community, which is further affirmed by culturing experiments. All *Acidithiobacillus* strains cultured from

snottites are autotrophic sulfur oxidizers, and produce abundant extracellular polymers *in vitro*.

Analysis of 16S rDNA sequences from *Acidithiobacillus* (both clones and isolates) revealed that snottites in Italy are inhabited by a different *Acidithiobacillus* phylotype than are those in Mexico (Fig 2). *Acidithiobacillus* spp. from the Italian caves are more closely related to *A. thiooxidans* (>99% similarity), while *Acidithiobacillus* spp. from the Mexican caves are more closely related to *A. caldus* (96% similarity). *Acidithiobacillus* strains from different caves within Italy are not distinguishable from each other by 16S rDNA sequence, and neither are *Acidithiobacillus* strains from the two Mexican caves (Fig. 2). Similarly, while sequences from the *Thermoplasmatales*, *Acidimicrobium*, *Sulfobacillus*, and TM6 lineages were found in snottites from both Frasassi and Villa Luz, they fall into distinct Italian or Mexican phylotypes.

Analysis of ITS sequences from 17 *Acidithiobacillus* isolates show that populations from separate Italian caves are genetically differentiated from each other (Fig. 3). Although these differences could not be observed from 16S rDNA sequence analysis, the ITS region is more variable and can

be used to resolve populations at a higher genetic resolution. These findings indicate that snottite microorganisms are endemic to specific caves. However, more samples are needed to confirm the pattern shown in Figure 3. Additional sequencing, currently in progress, will greatly expand the number of ITS sequences from Italian cave snottites. Further analysis using multilocus sequence typing (MLST) is also in progress.

Acknowledgements

We thank A. Montanari for logistical support and the use of facilities and laboratory space at the Osservatorio Geologico di Coldigioco (Italy). We thank L. Rosales-Lagarde, L. Hose, and S. Dattagupta for logistical support, insightful discussion, and field assistance with research in Mexico. We thank S. Mariani, S. Galdenzi, and S. Cerioni for expert advice and field assistance with research in Italy, and thank I. Shaperdoth, E. Lyon, T. Stoffer, and J. Patel for laboratory assistance at Pennsylvania State University. This work was supported by a generous graduate fellowship to DSJ in karst studies from the Cave Conservancy Foundation, and grants to JLM from the Biogeosciences Program of the National Science Foundation (EAR 0311854 and EAR 0527046) and NASA NAI (NNA04CC06A).

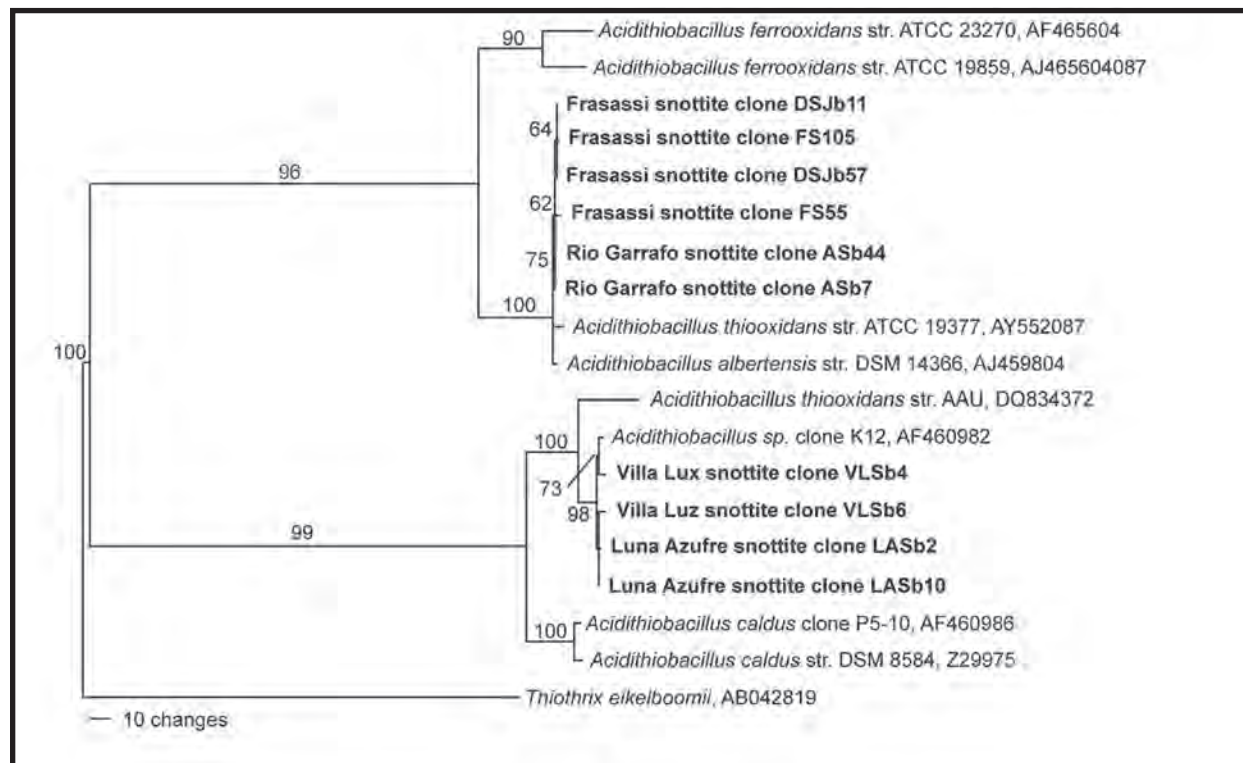

Figure 2: Maximum parsimony phylogenetic analysis of 16S rRNA gene sequences for the bacterial genus *Acidithiobacillus*. Sequences from this study are shown in bold. Bootstrap values greater than 50 are shown for each node. Note the significant separation between sequences from Mexico and Italy.

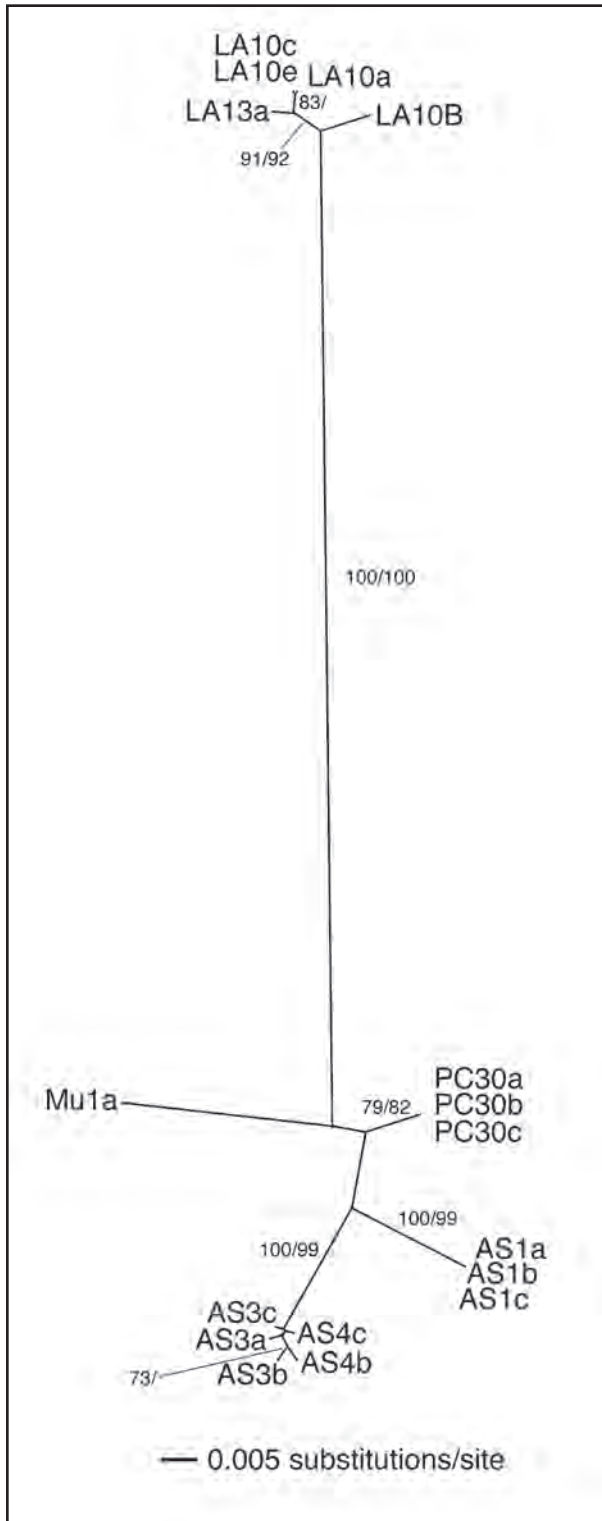

Figure 3: Unrooted neighbor joining tree of ITS sequences from *Acidithiobacillus* isolates. Sequences are coded by location as follows: AS = Rio Garrafo (Italy), Mu and PC = two different locations within Frasassi (Italy), LA = Luna Azufre (Mexico). Bootstrap values for neighbor joining and maximum parsimony greater than 50 are shown for each node. Note the significant separation among sequences from different Italian samples.

References

MACALADY, J.L., D.J. JONES, and E.H. LYON (2007) Extremely acidic, pendulous cave wall biofilms from the Frasassi cave system, Italy. *Environmental Microbiology* 9, 1402–1414.

OKSANEN, J., R. KINDT, P. LEGENDRE, B. O’HARA, G.L. SIMPSON, and M.H.H. STEVENS (2008). *Vegan: Community Ecology Package*. R package version 1.11-4. URL <http://vegan.r-forge.r-project.org/>.

SAGREDO, B., E. JEDLICKI, and O. ORELLANA (1992) Organization of the 16S-23S intergenic spacer region of the two rRNA operons from *Thiobacillus ferrooxidans*. *Geomicrobiology Journal* 10, 239–247.

SWOFFORD, D.L., (2000) *PAUP*: Phylogenetic analysis using parsimony and other methods (software)*. Sutherland, MA, Sinauer Associates.

WHAT CAN MOLECULAR MICROBIOLOGY TELL US ABOUT LASCAUX CAVE?

V. JURADO¹, F. BASTIAN², C. ALABOUVETTE², and C. SAIZ-JIMENEZ¹

¹Instituto de Recursos Naturales y Agrobiología, CSIC, Apartado 1052, 41080 Sevilla, Spain

²UMR INRA-Université de Bourgogne, Microbiologie du Sol et de l'Environnement, BP 86510, 21065 Dijon Cedex, France

Lascaux Cave contains paintings from the Upper Paleolithic period. Shortly after discovery in 1940, the cave was seriously disturbed due to major destructive interventions (e.g. excavations, air conditioning, artificial light installation, etc.). In 1963, the cave was closed due to algal growth on the walls. In 2000 the air conditioning system was replaced. In 2001, (a few months after that replacement), the vault, walls, sediments and soil were colonized by *Fusarium solani*. Later, black stains also appeared at the entrance, which extended in 2007 to the rest of the cave. Between 2001 and 2004, and again in 2008, the cave was treated with benzalkonium chloride. Recently, we have studied the microbial community in Lascaux Cave using molecular tools. We conclude that the indigenous bacterial community was replaced by microbial populations selected for by biocide application and other major destructive interventions. In addition to the microbial populations, entomopathogenic fungi play an important role in the cave and arthropods contribute to the dispersion of spores and fungal development.

1. Introduction

The conservation of Paleolithic paintings in caves is of great interest because they represent a priceless cultural heritage of all humankind. Among the Paleolithic paintings, those at Chauvet and Lascaux, France, and at Altamira in Spain, show remarkable sophistication. In recent times, some of the most important caves are suffering episodes of biological contamination that might damage the paintings (SCHABEREITER-GURTNER et al., 2002; DUPONT et al., 2007)

The Cave of Lascaux was discovered in 1940. The importance of its paintings was recognized shortly after its discovery and they are considered to be among the finest rock art paintings. As soon as it was open to the public the cave attracted many visitors, which amounted up to 1,800 every day in the 1960's (SIRE, 2006). This seriously disturbed the cave microclimate and had a strong impact on the whole cave.

Rock art tourism started at the beginning of the past century. At that time, no scientific knowledge on conservation problems existed, therefore management decisions adopted often resulted in great harm for the future of many caves. In the Cave of Lascaux, the conditions for visits between 1945 and 1948 and in 1958 (and the impact of massive tourism thereafter) were two of the main problems. In fact, lighting which began in 1960 caused the growth of a green biofilm on the wall paintings, initially identified as produced by *Chlorobotrys*, a Xanthophyta alga. Years later, the observation of zoospore formation

in one of the algal isolates, not previously detected, led to its proper specific determination as *Bracteacoccus minor*, a member of the Chlorophyta (LEFÉVRE, 1974). This green biofilm, considered as "la maladie verte", was the first one of the different contamination episodes suffered by the cave leading to its closure in 1963 due to the damage produced by visitors, lighting, and algal growth on the paintings.

SIRE (2006), in an excellent historical report on Lascaux management, stated that the treatments for defeating "la maladie verte" included a combined spray application of streptomycin and penicillin for bacteria and a subsequent treatment with formaldehyde for algae. These applications were effective until 1969 when it was necessary to start again and a programme of periodic maintenance and cleaning was adopted.

Between July and September 2001 the first evidence of a fungal outbreak appeared along with an associated bacterium *Pseudomonas fluorescens* (ALLEMAND, 2003; ORIAL AND MERTZ, 2006). In August 2001, treatment of the outbreak began but its rapid expansion led to a more intensive treatment in September using alkyl dimethylbenzylammonium chloride solutions plus streptomycin and polymyxin. The soils were treated with quicklime (SIRE, 2006). In 2004 benzalkonium chloride treatments were replaced by mechanical cleaning and air extraction and recovery of cleaning debris. At present there is strict control on access to the cave, and all interventions are recorded and discussed at the "Comité Scientifique International de la Grotte de Lascaux", created in 2002 by

the French Minister for Culture and Communication.

In 2007, black stains (Fig. 1) were found in the vault and passage banks. Although their origin is unknown, dematiaceous hyphomycetes, producing olive-green to black colonies, were isolated from the stains (BASTIAN AND ALABOUVETTE, 2009).

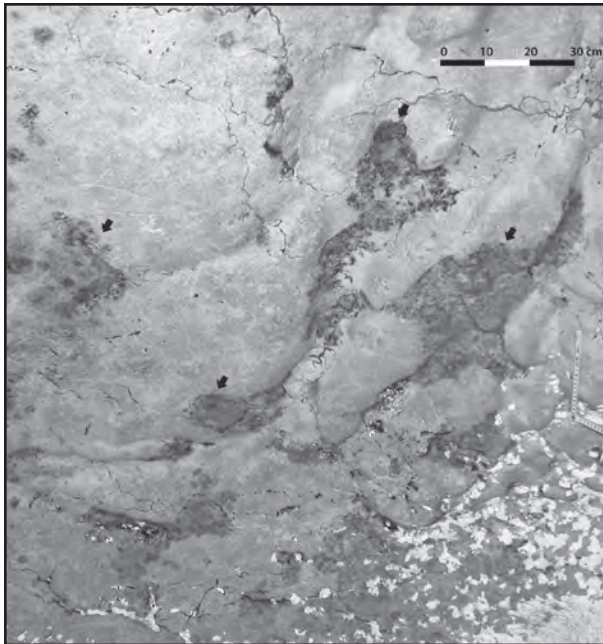

Figure 1: Black stains in the vault of the Passage, June 2008. Picture protected by copyright: Ministère de la Culture et de la Communication, DRAC d'Aquitaine and Centre National de la Préhistoire.

In the last year a debate was initiated in European and U.S. media on Lascaux black stains (e.g. DE ROUX, 2007; SIMONS, 2007; FOX, 2008). In addition to a historical description on the works carried out in the cave since the discovery, comments on the problem from different experts were summarized and the appearance of black stains noticed.

2. Cave Ecology

Why has Lascaux Cave suffered successive biological invasions since its discovery? The problem derives from the public interest and pressure of rock art tourism and the erroneous conception that all rock art should be exposed to public contemplation. This concept is in general opposition to effective conservation of the rock art. This is because opening a cave immediately results in a sudden change of microclimate with accompanying deterioration of speleothems and rock art paintings.

Opening a cave also impacts cave biology. Bacteria, fungi, and arthropods, all have constructed delicate and balanced

trophic relationships between predator and prey and the strength of interactions between species can be interrupted by tourism and cave preparation for tourism which include excavations and major destructive interventions.

The situation in Lascaux is particularly worrying because the cave has had two different fungal invasions in six years. In 2001 the presence of members of the *Fusarium solani* species complex (DUPONT et al., 2007) was reported. In addition, representatives of six fungal genera were found in the cave: *Chrysosporium*, *Gliocladium*, *Gliomastix*, *Paecilomyces*, *Trichoderma* and *Verticillium*. While no species identification was provided, the data reported by these authors suggest a strong correlation between cave fungi and arthropods because these fungal genera contain many entomopathogenic (insect infecting) species (SAMSON et al., 1988). Species of *Chrysosporium*, *Gliocladium*, *Paecilomyces*, and *Verticillium* have been isolated from larval and adult cadavers of cave crickets (GUNDE-CIMERMAN et al., 1998), and the association between fungi and insects in caves was recently reported by KUBÁTOVÁ AND DVORÁK (2005). These studies indicated the need for a detailed molecular study to decipher the origin of the microbial communities thriving in the cave.

3. Molecular Ecology

We collected eleven samples between April 2006 and January 2007 in different halls and galleries of Lascaux Cave. The Painted Gallery, Great Hall of Bulls, Chamber of Felines and Shaft of the Dead Man were selected to represent the different cave microenvironments. The samples included areas with white colonization, black stains, areas not apparently colonized (and therefore considered as references) and an area cleaned with biocides in 2004, without apparent colonization. Bacterial DNA was extracted from each sampling using a method adapted to small soil quantities as described previously (BASTIAN et al., 2009).

From the eleven samples, 696 clones were retrieved. Rarefaction analysis showed 90% clone coverage indicating that the majority of the bacterial diversity was detected. A considerable majority of the clone sequences retrieved could be assigned to defined taxa, from which the 10 most numerically dominant covered 533 clones or 76.6% of the total number of clones examined (Table 1). The two most abundant taxa were *Ralstonia* and *Pseudomonas*. The two most abundant phlotypes in the cave were *Ralstonia mannitolilytica* and *Ralstonia pickettii*, which together represent 17.8% of the total clones. It is noteworthy that only 5 sequences of *Pseudomonas fluorescens*, a species which

was reported to be abundant in the cave (ORIAL AND MERTZ, 2006) were recorded. In contrast, 77 and 47 sequences corresponding respectively to *R. mannitolilytica* and *R. pickettii* were detected. There is unfortunately no information on the bacteria present in Lascaux Cave before benzalkonium chloride treatments and therefore a comparison of these results to the pre-tourism microbial communities cannot be performed. However, the data suggest that years of benzalkonium chloride treatments in Lascaux Cave may have selected a mixed population of *Ralstonia* and *Pseudomonas*, both highly resistant to the biocide.

Taxa	Total No. of clones (%)
<i>Ralstonia</i>	207 (29.7)
<i>Pseudomonas</i>	167 (24.0)
<i>Escherichia</i>	28 (4.0)
<i>Achromobacter</i>	25 (3.6)
<i>Afpia</i>	22 (3.2)
<i>Ochrobactrum</i>	20 (2.9)
<i>Legionella</i>	19 (2.7)
<i>Alcaligenes</i>	15 (2.2)
<i>Stenotrophomonas</i>	15 (2.2)

To gauge the fungal diversity in Lascaux Cave, we similarly produced and analyzed a clone library of fungal 18S rDNA sequences. Six hundred and seven clones were partially sequenced (750 bp) and sorted into phylotypes. The 10 most abundant phylotypes represented 59.2% of the clones (Table 2). Only two out of these ten phylotypes are soil fungi: *Tricholoma saponaceum* and *Kraurogymnocarpa trochleospora*, while the others are entomophilous fungi, including the well-known entomopathogens *Isaria farinosa*, *Engyodontium album*, *Geosmithia putterillii*, etc. This indicates that entomopathogenic fungi play an important role in the cave and arthropods contribute to the dispersion of spores.

Phylotypes	Total No. of clones (%)
<i>Penicillium namyslowskii</i>	79 (13.0)
<i>Isaria farinosa</i>	53 (8.7)
<i>Aspergillus versicolor</i>	37 (6.1)
<i>Tolyposcladium cylindrosporium</i>	32 (5.3)
<i>Tricholoma saponaceum</i>	30 (4.9)
<i>Geomyces pannorum</i>	28 (4.6)
<i>Geosmithia putterillii</i>	28 (4.6)
<i>Engyodontium album</i>	28 (4.6)
<i>Kraurogymnocarpa trochleospora</i>	28 (4.6)
<i>Clavicipitaceae sp.</i>	17 (2.8)

4. Arthropod Ecology

In the last year, among other cavernicole arthropods, the springtail *Folsomia candida* (Collembola, Isotomidae) was found in Lascaux. This is a cosmopolitan opportunistic troglophile (facultative cavernicole, frequently completing its whole life cycle in caves, but not confined to this habitat) recorded from caves all over the world (PALACIOS-VARGAS, 2002). It is generally accepted that this springtail is found in cave sites which are not occupied by cave-adapted species and in disturbed and artificial areas. This fits well with the history of Lascaux as an example of ecologically disturbed site where *F. candida* likely was attracted from the top soil litter to the cave by the food source that represented the fungal outbreak.

Collembola are largely mycophagous and abundant *F. candida* specimens and were observed feeding on black stains (Fig. 2). *F. candida* prefer feeding on melanised fungal species (SCHEU AND SIMMERLING, 2004) over hyaline fungi, but they also feed on *Fusarium* hyphae (SABATINI AND INNOCENTI, 2000), several *Pseudomonas* spp., including *P. fluorescens* (THIMM et al., 1998) and nematodes (LEE AND WIDDEN, 1996).

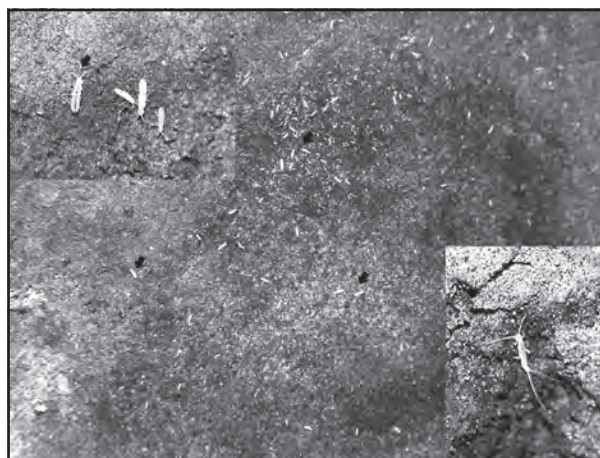

Table 2: Most abundant fungal phylotypes in Lascaux Cave.

Folsomia candida is a known vector for microorganisms. DROMPH (2003) reported that collembola can carry entomopathogenic fungi, and GREIF AND CURRAH (2007) isolated species of the fungal genera *Acremonium*, *Beauveria*, *Cladosporium*, *Cryptendoxyla*, *Geomyces*, *Gliocladium*, *Hormiactis*, *Leptographium*, *Oidiodendron*, *Penicillium*, and *Verticillium* from collembola. The high density of collembola that come in contact with bacterial cells, mycelial fragments and spores suggest that these arthropods can help disperse bacteria (SCHEU

AND SIMMERLING, 2004) and fungi (THIMM et al., 1998) throughout an environment. In addition, the gut of *F. candida* is a selective habitat and a vector for microorganisms (THIMM et al., 1998).

SABATINI et al. (2004) showed that some collembola preferred *Fusarium* as food and that a few colonies of *Fusarium* developed from their fecal pellets. We have observed that when *F. candida* is feeding on Lascaux black stains, and on peat debris in the laboratory, they have produced black fecal pellets. Also SAWAHATA (2006) has observed the production of black fecal pellets when collembolans consumed the hymenial area of agaric fruit bodies. Such fecal pellets can contain fungal spores that germinate once deposited on the wet rock surface. While the ability of spores to germinate may be reduced by gut passage, it is not uncommon for almost all fecal pellets produced by arthropods to contain some germinable spores (THIMM et al., 1998; WILLIAMS et al., 1998). Therefore, it could be possible that collembolans contribute to the sudden appearance of black stains everywhere in Lascaux Cave, although this hypothesis needs to be confirmed.

The presence of *F. candida* in Lascaux Cave after the first fungal outbreak may be explained by its feeding preferences. Fungi produce volatile compounds that are potentially attractive to collembola (BENGTSSON et al., 1988). Grazing on the black stains might be a consequence of the presence of melanised fungi in the black stains. Indeed these are also the most palatable fungi for mites (SCHNEIDER AND MARAUN, 2005) which suggest that a survey for this group of arthropods should be carried out in the cave. Interestingly, members of the family Campodeidae (Diplura) were observed in the black stains (Figure 2). Most Diplura are predators and their diet includes collembola and mites. They may also survive on vegetable debris and fungal mycelia.

5. Conclusions

This study raises intriguing questions about the past, present and future management of show caves. In fact, microorganisms in Lascaux Cave grow as biofilms which consist of assemblages containing many species of bacteria, fungi, protozoa, etc. Our research suggests that as a result of years of biocide treatments, the indigenous microbial communities of Lascaux Cave have been replaced by microbial populations selected for by biocide application.

It appears that arthropods contribute to the dispersion of fungal spores inside the cave, likely by contact with their bodies, dissemination of their fecal pellets and growth on their cadavers. The composition of the fungal community

is largely influenced by arthropod colonization and activity, with the collembola of primary significance. Coleoptera likely play a role in fungal community structure, however, further studies are needed to verify this and the degree of association of *Geosmithia* species with cave beetles.

The black stains in Lascaux Cave seem to be related to the presence and grazing effects of the cavernicole population. A careful study of the arthropods, the fungal ecology and the dispersion patterns is needed in order to complete our understanding of the food web and to help confirm the suggested origin of black stains in the cave.

Acknowledgements

We thank the Spanish project CGL2006-07424/BOS for support, the research project “Microbiology-Microclimate”, from the Ministry of Culture and Communication, France, and facilities at DRAC Aquitaine. Ms. M-A. Sire and A. Moskalik-Detalle are acknowledged for their helpful comments, *Folsomia candida* specimens, and pictures. Prof. R. Jordana confirmed the collembola identification. This is a TCP CSD2007-00058 paper.

References

- ALLEMAND, L. (2003) Qui sauvera Lascaux? *La Recherche* **363**, 26–33.
- BASTIAN, F. and C. ALABOUVETTE (2009) Lights and shadows on the conservation of a rock art cave: The case of Lascaux Cave. *International Journal of Speleology* **38**, 55–60
- BENGTSSON, G., A. ERLANDSSON, and S. RUNDGREN (1988) Fungal odour attracts soil Collembola. *Soil Biology and Biochemistry* **20**, 25–30.
- DE ROUX, E. (2007) Les fresques de Lascaux menacées par des moisissures. *Le Monde*, 26 November 2007.
- DROMPH, K.M. Collembolans as vectors of entomopathogenic fungi. *Pedobiologia* **47**, 245–256 (2003).
- DUPONT, J., C. JACQUET, B. DENNETIERE, S. LACOSTE, F. BOUSTA, G. ORIAL, C. CRUAUD, A. COULOUX and M-F. ROQUEBERT (2007) Invasion of the French Paleolithic painted cave of Lascaux by members of the *Fusarium solani* species complex. *Mycologia* **99**, 526–533

- FOX, J.L. (2008) Some say Lascaux Cave paintings are in microbial "crisis" mode. *Microbe* **3**, 110–112.
- GREIF, M.D. and R.S. CURRAH (2007) Patterns in the occurrence of saprophytic fungi carried by arthropods caught in traps baited with rotted wood and dung. *Mycologia* **99**, 7–19.
- GUNDE-CIMERMAN, N., P. ZALAR, and S. JERAM. (1998) Mycoflora of cave cricket *Troglophilus neglectus* cadavers. *Mycopathologia* **141**, 111–114.
- KUBÁTOVÁ, A. and L. DVORÁK (2005) Entomopathogenic fungi associated with insect hibernating in underground shelters. *Czech Mycology* **57**, 221–237.
- LEE, Q. and P. WIDDEN (1996) *Folsomia candida*, a "fungivorous" collembolan, feeds preferentially on nematodes rather than soil fungi. *Soil Biology and Biochemistry* **28**, 689–690.
- LEFÉVRE, M. (1974) La maladie verte de Lascaux. *Studies in Conservation* **19**, 126–156.
- ORIAL, G. and J-D. MERTZ (2006) Etude et suivi des phénomènes microbiologiques. *Monumental* **2**, 76–86.
- PALACIOS-VARGAS, J.G. (2002) La distribución geográfica de los Collembola en el mundo subterráneo. *Boletín de la Sociedad Venezolana de Espeleología* **36**, 1–5.
- SABATINI, M.A. and G. INNOCENTI (2000) Soil-borne plant pathogenic fungi in relation to some collembolan species under laboratory conditions. *Mycology Research* **104**, 1197–1201.
- SABATINI, M.A., M. VENTURA, and G. INNOCENTI (2004) Do Collembola affect the competitive relationships among soil-borne plant pathogenic fungi? *Pedobiologia* **48**, 603–608.
- SAMSON, R.A., J-P. LATGE, and H.C. EVANS (1988) *Atlas of Entomopathogenic Fungi*. Springer Verlag, Berlin.
- SAWAHATA, T. (2006) Hymenial area of agaric fruit bodies consumed by Collembola. *Mycoscience* **47**, 91–93.
- SCHABEREITER-GURTNER, C., C. SAIZ-JIMENEZ, G. PIÑAR, W. LUBITZ and S. ROLLEKE (2002) Altamira cave paleolithic paintings harbour partly unknown bacterial communities. *FEMS Microbiology Letters* **211**, 7–11.
- SCHEU, S. and F. SIMMERLING (2004) Growth and reproduction of fungal feeding Collembola as affected by fungal species, melanin and mixed diets. *Oecologia* **139**, 347–353.
- SCHNEIDER, K. and M. MARAUN (2005) Feeding preferences among dark pigmented fungal taxa ("Dematiacea") indicate limited trophic niche differentiation of oribatid mites (Oribatida, Acari) *Pedobiologia* **49**, 61–67.
- SIMONS, M. (2007) Fungus once again threatens French cave paintings. *New York Times*, December 9, 2007.
- SIRE, M-A. (2006) De l'élimination des champignons au constat d'état. *Monumental* **2**: 68–75.
- THIMM, T., A. HOFFMANN, H. BORKOTT, J.C. MUNCH, and C.C. TEBBE (1998) The gut of the soil microarthropod *Folsomia candida* (Collembola) is a frequently changeable but selective habitat and a vector for microorganisms. *Applied and Environmental Microbiology* **64**, 2660–2669
- WILLIAMS, R.H., J.M. WHIPPS, and R.C. COOKE (1998). Role of soil mesofauna in dispersal of *Coniothyrium minitans*: Mechanisms of transmission. *Soil Biology and Biochemistry* **30**, 1937–1945.

MICROBIAL DIVERSITY IN KARTCHNER CAVERNS, A CARBONATE CAVE IN SOUTHERN ARIZONA, USA

ANTJE LEGATZKI¹, MARIAN ORTIZ¹, JULIA W. NEILSON¹, MATT CREAMER¹, KARIS NELSON¹, HANH TH. CHU¹, CODIE E. BANCZAK², BARRY M. PRYOR³, LELAND S. PIERSON III³, RAINA M. MAIER¹, MICHAEL J. VAUGHAN³, ROBERT R. CASAVANT³, RICKARD S. TOOMEY⁴

¹*Department of Soil, Water and Environmental Science, and*

²*Division of Plant Pathology, Department of Plant Sciences, University of Arizona, Tucson, AZ 85721 USA*

³*Kartchner Caverns State Park, Benson, AZ 85602 USA*

⁴*Mammoth Cave International Center for Science and Learning, WKU, 1906 College Heights Blvd #31066, Bowling Green, KY 42101-1066 USA*

Extended Abstract

Kartchner Caverns, a cave formed in carbonate rock near Benson Arizona, US, was discovered in 1974. The land containing the cave was purchased by the State of Arizona in 1988 and the cave was then carefully developed for tourism (opening in 1999) with the goal of maintaining its status as a living (dripping) cave. Its careful development and the fact that it is considered one of the world's top ten caves formed in carbonate rock in terms of mineral and speleothem diversity, led the National Science Foundation to provide funds to designate Kartchner Caverns as a Microbial Observatory (MO) in 2006. The goal of the Kartchner MO is to study the microbial communities in the cave and their possible role in speleothem growth. Facets of research that have been performed in the Kartchner MO include (i) a comparison of intra- and inter-speleothem variability in bacterial community profiles; where variability among samples was compared using denaturing gradient gel electrophoresis (DGGE) analysis of 16S rRNA gene PCR products from community DNA extracts obtained from speleothems, (ii) identification of the dominant archaeal and bacterial populations on two speleothems as measured by excision and sequencing of DGGE bands and by 16S rRNA Phylochip analysis, (iii) the impact of tourism on microbial communities found in Kartchner as measured by the dominant cultured isolates in toured versus untoured portions of the cave, (iv) a comparison of the cultured vs. noncultured bacterial communities found on Kartchner speleothems, and (v) physiological attributes of cultured isolates from Kartchner including calcium carbonate deposition, and production of antimicrobials, siderophores, and biosurfactants.

Intra- and inter-speleothem variability of uncultured bacterial communities in Kartchner Caverns. The purpose of this study was to analyze the intra- and inter-speleothem variability of the microbial community in the cave in

order to determine the spatial diversity of microbial populations within the cave and to evaluate the effect of mineralogical differences between different speleothems on microbial community structure. Samples were taken in a low disturbance area from a total of 9 different stalactites and one flowstone which varied in color, size, structure and location. Total genomic DNA was extracted from each sample and used to amplify a 336 bp 16S rRNA gene fragment. The amplified products from each microbial community were separated using denaturing gradient gel electrophoresis (DGGE) to generate a community profile for each sample. Community profiles were analyzed using the Quantity One software (BioRad Laboratories Inc., Hercules, Calif) and similarities were evaluated by nonmetric multidimensional scaling analysis (NMDS) (Rosario et al., 2007). Three of the 10 speleothems were selected for further analysis for the intra-variability study. Samples for the intra-variability study were taken along the vertical axis of each speleothem. NMDS analysis of the intra-speleothem microbial communities indicated that the bacterial communities sampled from the same speleothem were more similar to each other than to communities found on other speleothems. Results from the NMDS analysis of the inter-speleothem study suggest that speleothem bacterial communities are generally more similar among formations that are spatially closer together.

Identification of the dominant bacterial populations and archaeal bands on two speleothems as measured by excision and sequencing of DGGE bands. This study was performed in a second low disturbance area of the cave. We examined the bacterial and archaeal diversity on two formations. For bacteria, we compared the DGGE profiles of a bacterial 16S rRNA gene fragment of the triplicate samples from each stalactite. The identified 16S rRNA fragments belong amongst other to the phyla Proteobacteria, Chloroflexi, Actinobacteria, and

Acidobacteria. For archaea, a similar approach was used. The archaeal profiles of a 512 bp 16S rRNA gene fragment were analyzed. The archaeal profiles contained fewer bands and exhibited more variation among the three replicate samples.

Cultured Diversity in Kartchner Caverns. The cultured bacterial diversity of the cave was also examined in response to the hypothesis that it is important to be able to determine not only 'who' is there, but also 'what' the different members of the community are doing and how those members influence the chemical and physical attributes of the immediate environment.

Bacteria were cultured from two low disturbance areas of the cave on R2A. The isolates recovered included 15 α -Proteobacteria (68%), four Actinobacteria (18%), one each β - and γ -Proteobacteria, and one Firmicutes. Two approaches were taken to evaluate the cultured diversity recovered from the cave. First, one sample was cultured on two alternative minimal media to compare the effect of culture medium on the diversity of isolates recovered. The media used included VL55/xylan (Joseph et al., 2003) and a Kartchner Cave Medium (KCM) that contained 0.01% yeast extract, 0.326% ground speleothem, and 1.5% noble agar. Results show that isolates recovered from VL55/xylan and KCM media also belonged to the same divisions as those cultured on R2A, Proteobacteria, Actinobacteria and Firmicutes. However, different subpopulations within these phyla were recovered and the distribution of these populations among the three phyla was different. The results of this study confirm the importance of using a variety of culture media to expand the recovered diversity of the cultured library.

The second approach, was to use DGGE profile analysis to compare the diversity revealed by culture versus nonculture-based analysis. The relative diversity was evaluated by comparing the 16s rRNA PCR amplicon DGGE profiles obtained from cultured isolates washed from an R2A plate (plate-wash profile) with community DNA extracted directly from the original sample (community extract profile). For this study we selected five of the stalactites used in the inter-variability study. Plate-wash profiles indicate that there were 4 to 11 culturable populations in each sample. We then compared the DGGE plate-wash profiles with the community extract profiles. A comparison of the total number of bands present from the community extract profiles with those from the plate-wash profiles shows that the number of bands in whole community extract profiles is 2.5 to 6.8-fold greater than

those recovered from the R2A. This confirms that only a low percentage of the bacterial community is recovered on R2A medium under the chosen growth conditions. Interestingly, a comparison of the bands detected by the plate-wash method indicates that 40 to 75% of the bands present in the plate-wash profiles were not present in the community extract profiles.

Physiological attributes of isolates in the Kartchner Caverns culture library. In order to identify microbial properties that might be involved in speleothem formation and to screen for novel metabolic capabilities, we have begun to characterize a selection of isolates for activities or secondary metabolites that could influence mineral deposition or distribution in speleothems including calcium carbonate precipitation and the production of biosurfactants and siderophores. A recognized limitation to these screening efforts is the inability of many of the recovered isolates to grow on the screening medium utilized.

We first examined the ability of cave isolates to precipitate calcium carbonate on agar plates using three different media (B4 medium with and without glucose and R2A) amended with 0.016 mM calcium acetate (Boquet et al., 1973). The most consistent results were observed on the B4 medium without glucose. Results indicated that 86% of the isolates that were able to grow on this medium were able to precipitate crystals on plates supplemented with calcium acetate. Isolates in the culture library were then screened for siderophore and biosurfactant production. Siderophore production was screened on CAS agar plates (Schwyn and Neilands, 1987). Growth of isolates on the CAS plates was problematic, only 43% of the isolates grew and in some cases growth was very limited. Approximately 50% of the isolates that were able to grow on CAS medium produced siderophores. Biosurfactant production was screened in MSM medium containing glucose (Boudour and Miller-Maier, 1998). Only seven of the 31 isolates examined in this study grew on this medium and none were positive for biosurfactants production.

References

- BODOUR, A.A. and R.M. MILLER-MAIER (1998) Application of a modified drop-collapse technique for surfactant quantitation and screening of biosurfactant-producing microorganisms. *Journal of Microbiological Methods* 32, 273–280.

- BOQUET, E., A. BORONAT, and A. RAMOS-CORMENZANA (1973) Production of calcite (calcium-carbonate) crystals by soil bacteria is a general phenomenon. *Nature* 246, 527–529.
- JOSEPH, S.J., P. HUGENHOLTZ, P. SANGWAN, C.A. OSBORNE, and P.H. JANSSEN (2003) Laboratory cultivation of widespread and previously uncultured soil bacteria. *Applied and Environmental Microbiology* 69, 7210–7215.
- ROSARIO, K., S.L. IVERSON, D.A. HENDERSON, S. CHARTRAND, C. McKEON, E.P. GLENN, and R.M. MAIER (2007) Bacterial community changes during plant establishment at the San Pedro River mine tailings site. *Journal of Environmental Quality* 36, 1249–1259.
- SCHWYN, B. and J.B. NEILANDS (1987) Universal chemical assay for the detection and determination of siderophores. *Analytical Biochemistry* 160, 47–56.

SULFUR-OXIDIZING EXTREMOPHILES FROM THE CAVES OF ACQUASANTA TERME, ITALY

J.L. MACALADY¹, D.S. JONES¹, D. TOBLER¹, I. SCHAPERDOTH¹, S. GALDENZP, and M. MAINIERO³

¹Pennsylvania State University, Geosciences, 224 Deike Building, University Park PA 16802 USA jmacalad@geosc.psu.edu

²Viale Verdi, 10 - 60035 Jesi (Italy)

³Via Francesco Podesti, 8 - 60122 Ancona (Italy)

Extended Abstract

Sulfidic caves have attracted the attention of geomicrobiologists because of their potential as model systems for microbial evolution and ecology. Caves in the Rio Garrafo canyon near Acquasanta Terme, Italy, have the highest temperatures among sulfidic caves studied to date (water and air temperatures 35° to 50° C). Despite the presence of abundant microbial biofilms in this unique environment, the geomicrobiology of the Rio Garrafo caves has not been explored previously. Here we present data on the geochemistry, microbial community structure, biodiversity, and evolutionary relationships of microorganisms in both near-neutral and extremely acidic environments. Water in the thermal sections has 400–810 μM sulfide, <10 μM O_2 , pH 6.3–6.7, and conductivity 6500–10,500 $\mu\text{S}/\text{cm}$. Air located several meters above the thermal water has 5–10 ppm SO_2 , 15–250 ppm H_2S , and 5000–28,000 ppm CO_2 . Biofilms in the near-neutral cave streams have seasonally variable community compositions reflecting the dynamic hydrology and geochemistry of the cave system. Based on 16S rDNA cloning and fluorescence *in situ* hybridization (FISH), lithoautotrophic *Gamma*- and *Epsilonproteobacteria* distantly related to other subsurface microorganisms are the principle biofilm architects. *Deltaproteobacterial* sequences also present in the biofilms may represent novel sulfate reducing taxa. Acidic snottite and “snot curtain” biofilms (pH 0–1) on cave walls exposed to sulfidic air currents host extremely acidophilic bacteria, archaea, fungi, and protists. Rio Garrafo snottites contain a single bacterial phylotype related to *Acidithiobacillus thiooxidans* and representatives of the archaeal genus *Ferroplasma*. Their community composition and species richness (very low) is comparable to well-studied snottites from the Frasassi cave system located ~100 km north. Snot curtains occur on walls exposed to relatively higher temperature and $\text{H}_2\text{S}_{(\text{g})}$ concentrations, and contain a more diverse microbial community with several bacterial species and very few archaea. Initial observations suggest that the Rio Garrafo microorganisms are more closely related to microorganisms retrieved from other sulfidic caves than to microorganisms from other thermal and sulfide-rich environments such as hot springs and deep-sea

hydrothermal vents. We anticipate that further study of the Rio Garrafo caves will provide new insights into the effects of temperature, bedrock lithology, pH, and sulfur concentrations on the microbial ecology of sulfur cycling in the subsurface.

Aqueous geochemical parameters were measured in the field using portable pH, conductivity, temperature probes (WTW, Inc.). Dissolved sulfide and oxygen concentrations were measured in the field using a portable spectrophotometer (Hach, Inc.). Additional parameters were measured in the lab on preserved samples using ion chromatography (IC) and inductively coupled plasma atomic emission spectroscopy (ICP-AES). Air chemistry was measured in the field using Draeger tubes and a manual pump, and with calibrated portable gas sensors (Enmet, Inc.). DNA was extracted from biofilm samples preserved in the field in RNAlater (Ambion, Inc.) as previously described (Macalady et al. 2008). Bacterial 16S rRNA genes were amplified using the primer set 27f/1492r and cloned using a TOPO TA cloning kit (Invitrogen, Inc.). Colonies containing 16S rDNA inserts were amplified using plasmid-specific M13r/M13f primers and sequenced at the Penn State University nucleic acid sequencing facility. Returned sequences were manually checked and assembled using CodonAligner, aligned using the NAST aligner (www.greengenes.lbl.gov), and checked for chimeras using the online analytical tools Bellerophon and CHIMERA_CHECK. Non-chimeric sequences were loaded into ARB software for phylogenetic analyses. Bacteria, archaea, fungi, and protists were identified using epifluorescence microscopy as previously described (Macalady et al. 2007).

Extremely acidic snottites from the Rio Garrafo caves have similar pH and taxonomic composition as snottites from the lower-temperature Frasassi cave system (13 °C air) approximately 100 km distant (Macalady et al. 2007). They grow on gypsum crusts and selenite crystals (Fig. 1) not directly exposed to the main flow of vapors rising from the thermal stream (~30 °C air). They differ from Frasassi snottites in that they have a larger proportion of archaea,

up to 50% of cells. The ecological causes and consequences of snottite community composition are the subject of ongoing work, including metagenomic sequencing of the Rio Garrafo samples. Directly in the path of rising thermal vapors (45-50 °C air), snot curtains develop directly on the surface of corroding limestone. Like snottites, curtains are extremely acidic (pH <1). Unlike snottites, snot curtains contain few archaea and more diverse bacteria. Their higher overall species richness may be related to the presences of relatively neutral-pH spatial niches near and in contact with the limestone cave walls.

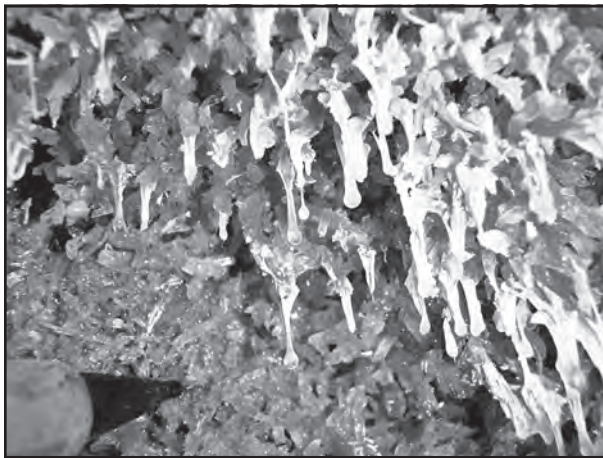

Figure 1: Rio Garrafo snottites developed on the surface of calcium sulfate (selenite) crystals. The crystals and associated acidic biofilms coat the limestone walls of the cave where sulfidic vapor rises from the water table. Pencil at lower left for scale.

Neutral-pH biofilms developed in the thermal Rio Garrafo streams are populated with representatives of sulfur-oxidizing and sulfur-reducing clades, and representatives of clades with no cultivated representatives for which no metabolic information can be inferred (Figs. 2 and 3). The principle biofilm architects are filamentous *Epsilonproteobacteria*, consistent with a predictive model of sulfur-oxidizer

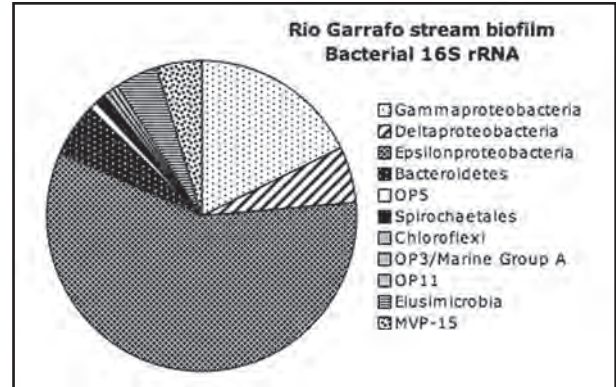

Figure 2: Taxonomic composition of bacteria in Rio Garrafo stream biofilms collected in 2005 and 2007. A total of 174 clones are represented. The composition of the two libraries is similar. Major lineages were identified by sequence analysis using the software program ARB. Most lineages are represented in the libraries by a single phylotype (> 98% sequence similarity). Exceptions are annotated with the number of phylotypes on the diagram.

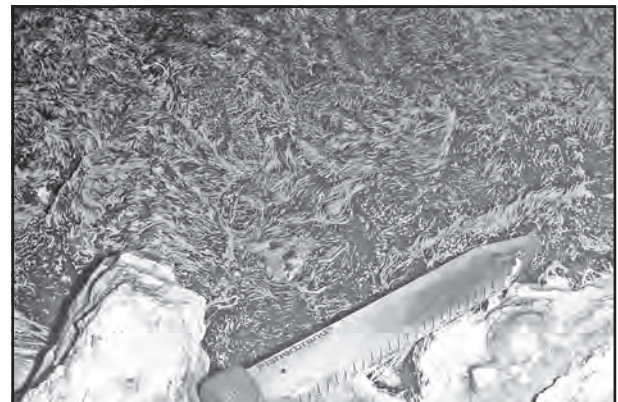

Figure 3: Rio Garrafo stream biofilm (short white streamers) developed on the surface of dark gray stream mud. The collection tube at bottom center is approximately 1 cm in diameter.

niche differentiation developed in earlier work on stream biofilms from the Frasassi cave system (Macalady et al.,

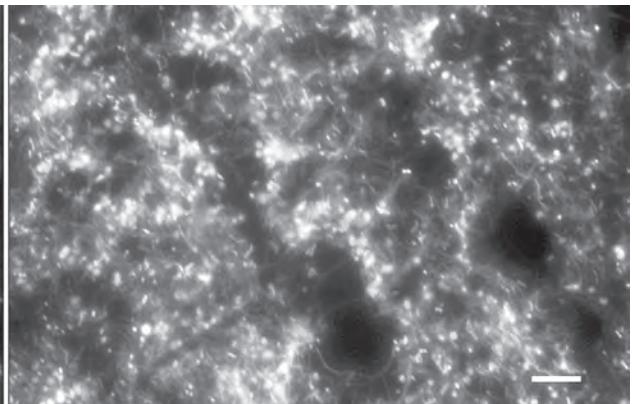
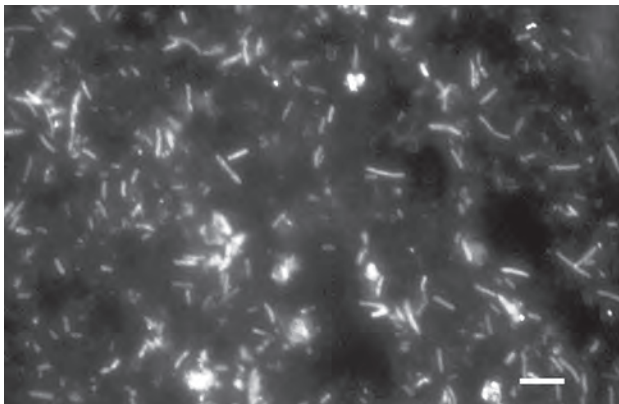

Figure 4

2008). This model based on sulfur and oxygen supply ratios appropriately predicts the predominance of filamentous Epsilonproteobacteria in the Rio Garrafo stream biofilms, despite significant differences among the stream in conductivity and temperature. Abundant rod-shaped cells identified as sulfur-reducing *Deltaproteobacteria* using fluorescence in situ hybridization (FISH) (Fig. 4) indicate that the biofilm hosts a complete sulfur cycle. Sulfur cycling is made possible by the presence of both oxic and anoxic spatial niches within the biofilms, and enhances acid production and limestone dissolution (Macalady et al. 2006).

Acknowledgements

This research was funded by grants from the National Science Foundation and the NASA Astrobiology Institute (PSARC). We are grateful to S. Dattagupta, L. Hose, G. Filippini and members of the Associazione Speleologica Acquasantana, F. Baldoni, and S. Cerioni for their assistance in the field. We also thank A. Montanari of the Osservatorio Geologico di Coldigioco for logistical support and laboratory space during field campaigns.

References

- MACALADY, J.L., D.S. JONES, and E.H. LYON (2007) Extremely acidic, pendulous microbial biofilms from the Frasassi cave system, Italy. *Environmental Microbiology* **9**(6), 1402–1414.
- MACALADY, J.L., E.H. LYON, B. KOFFMAN, L.K. ALBERTSON, K. MEYER, S. GALDENZI, and S. MARIANI. (2006) Dominant microbial populations in limestone-corroding stream biofilms, Frasassi cave system, Italy. *Applied and Environmental Microbiology* **72** (8), 5596–5609.
- MACALADY, J.L., S. DATTAGUPTA, I. SCHAPERDOTH, D.S. JONES, G.K. DRUSCHEL, and D. EASTMAN (2008) Niche differentiation among sulfur-oxidizing bacterial populations in cave waters. *International Society for Microbial Ecology Journal* **2**, 590–601.

THE HUNT FOR THE HIDDEN BIODIVERSITY IN SULFIDIC CAVES: A CASE STUDY OF UNIQUE CHLOROFLEXI AFFILIATED SPECIES AND OTHER NOVEL SPECIES FROM LOWER KANE CAVE, WYOMING, USA

DANIELA B. MEISINGER¹, ANNETTE SUMMERS ENGEL², MEGAN L. PORTER³, MICHAEL SCHMID⁴, STEFAN SPRING⁵, NATUSCHKA M. LEE¹

¹TUM - Technische Universität München, Department of Microbiology, D-85354 Freising, Germany

²Louisiana State University, Department of Geology and Geophysics, Baton Rouge, Louisiana 70803, USA

³University of Maryland Baltimore County, Department of Biological Sciences, Baltimore, MD 21250

⁴Helmholtz Zentrum München, German Research Center for Environmental Health (GmbH), Ingolstaedter Landstrasse 1, D-85764 Neuherberg, Germany; ⁵DSMZ German Collection of Microorganisms and Cell Cultures, D-38124 Braunschweig, Germany

Extended Abstract

Lower Kane Cave (LKC), Wyoming, USA, is a sulfidic cave system containing microbial mats that are structured with filamentous and web-like morphotypes at the mat surface. Our main research objective in LKC is to investigate its microbial diversity and ecosystem function, and to explore basic principles of biologic and geologic controls of microbial diversity and ecosystem function in a sulfur-based terrestrial subsurface. Our previous work focused on characterizing the diversity of the microbial communities, which are dominated by putative chemolithoautotrophic, sulfur-oxidizing groups within the *Epsilonproteobacteria* and *Gammaproteobacteria* from the aerobic portions of the mats. In contrast, the anaerobic mat interior has an unexpectedly diverse microbial community dominated by unculturable members of the *Deltaproteobacteria*, *Chloroflexi*-affiliated bacteria, and novel candidate groups. The function of most of these putative anaerobic groups is not yet known. An intense approach, consisting of a comparative phylogenetic-biogeographic inventory of all relevant relatives retrieved from subsurface systems, in particular caves and anaerobic, oligotrophic environments, 16S rRNA-based, DGGE screening, 16S rRNA-based clone libraries, standard fluorescence *in situ* hybridization, CARD-FISH, and different enrichment studies using microbial mat samples from throughout the cave, was undertaken to trace some of the novel groups, in particular the novel *Chloroflexi*-affiliated species, in more detail.

Interestingly, the DGGE screening and clone library approach using primers targeting the *Chloroflexi* phylum showed that representatives could be detected in nearly every sample investigated and that additional, novel *Chloroflexi*-affiliated species were retrieved. Standard FISH tools, previously successful in detecting dominant bacteria in the aerobic mat portions, failed to detect most of the novel putative anaerobic groups, such as the *Chloroflexi* affiliated

species. However, an adapted CARD-FISH protocol detected significant numbers of filamentous *Chloroflexi*-affiliated cells, in close proximity to other filamentous cells, in nearly every mat sample. These results suggest that at least some of the novel putatively anaerobic groups detected by the clone library constitute a significant part of the microbial community, and that our concept of ecosystem function in the context of key microbial groups based on *Epsilonproteobacteria* and *Gammaproteobacteria* may need some revision. At the current stage, we are not able to postulate their role as we do not know the function of this group. However, we have undertaken a series of different cultivation conditions, aided by standard FISH, CARD-FISH, and DNA-based functional gene screening to guide us in the selection of appropriate conditions and to explore the dynamics and interactions of putative sulfur-oxidizing bacteria and the novel putative anaerobic groups. This study clearly demonstrates our limited comprehension of the true biodiversity and function in sulfidic cave microbial communities even in a well-studied system like Lower Kane Cave. This study further underscores how important it is to continue to develop tools for enhanced detection of, in particular, novel microbial groups.

References

- Engel, A.S., N.M. Lee, M.L. Porter, L.A. Stern, P.C. Bennett, and M. Wagner. 2003. Filamentous *Epsilonproteobacteria* dominate microbial mats from sulfidic cave springs. *Appl Environ Microbiol* 69, 5503.
- Engel, A.S., M.L. Porter, L.A. Stern, S. Quinlan, and P.C. Bennett (2004). Bacterial diversity and ecosystem function of filamentous microbial mats from aphotic (cave) sulfidic springs dominated by chemolithoautotrophic "*Epsilonproteobacteria*". *FEMS Microbiol. Ecol.* 51, 31–53.

Engel, A.S., D.B. Meisinger, M.L. Porter, M. Schmid, L.A. Stern, K.H. Schleifer, and N.M. Lee. 2009. Nutrient Spiraling Establishes Phylogenetic and Functional Diversity in Microbial Mats from Lower Kane Cave , Wyoming (USA). In review, ISME J.

Meisinger, D.B., J. Zimmermann, W. Ludwig, K.H. Schleifer, G. Wanner, M. Schmid, P.C. Bennett, A.S. Engel, and N.M. Lee. 2007. *In situ* detection of novel *Acidobacteria* in microbial mats from a chemolithoautotrophically-based cave system (Lower Kane Cave, Wyoming, USA). Environmental Microbiology, vol 9 (6), 1523–1534.

THE GEOLOGY OF CAVE POOLS: CLUES FOR THE MICROBIOLOGY

L.A. MELIM¹, D. GUSTAFSON¹, A. KOOSER², D.E. NORTHUP³, and M.N. SPILDE⁴.

¹ Geology Dept., Western Illinois University, 1 University Circle, Macomb, IL 61455 USA

² Department of Earth and Planetary Sciences, University of New Mexico, Albuquerque, NM 87131 USA

³ Biology Department, University of New Mexico, MSC03 2020, Albuquerque, NM 87131-0001 USA

⁴ Institute of Meteoritics, University of New Mexico, MSC03-2050, Albuquerque, NM 87131 USA

Extended Abstract

The floor and sides of cave pools are usually coated in calcite and/or aragonite (pool spar, shelfstone, etc.) that precipitate as a result of CO₂ degassing from the pool water (HILL and FORTI, 1997). In some pools, however, speleothems such as pool fingers, u-loops, and webulite (Figs 1 & 2), display characteristics of biothems. Biothems are speleothems with some evidence of being influenced directly or indirectly by microorganisms (CUNNINGHAM et al, 1995; QUEEN and MELIM, 2006). We have developed a database of 89 (mostly fossil) pools in Carlsbad Cavern, New Mexico. Of these, 53% contain some kind of biothem. With this large database, we can begin to identify the pool settings conducive to biothem formation.

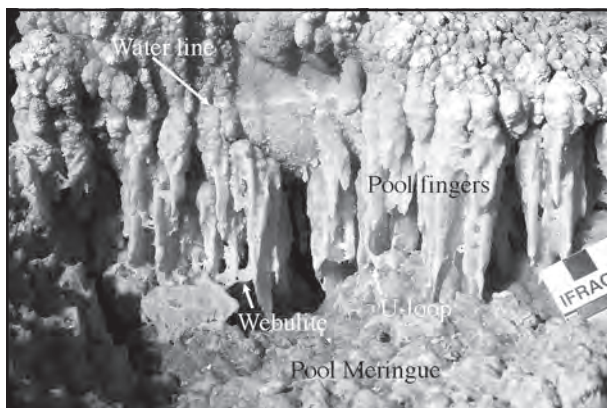

Figure 1: Pool fingers extending down from shelfstone in a paleopool in the Big Room, Carlsbad Cavern. Note that the fingers extend down from the shelf but not from deeper overhangs in the lower left (arrow). Photo by K. Ingham.

Cave pools in Carlsbad Cavern separate into two main types: (1) pools with high water through-put and (2) pools with low through-put (effectively pools with interior drainage). High water through-put is indicated by many inflow points (drips and flow from flowstone) and overflow points coated in substantial flowstone. In contrast, low-flow pools have little inflow and often lack an overflow point even though they apparently maintained a steady water line long enough for a well developed pool line of shelfstone and/or pool spar to have formed. Although exceptions exist, pools with lesser flow are more likely to contain biothems,

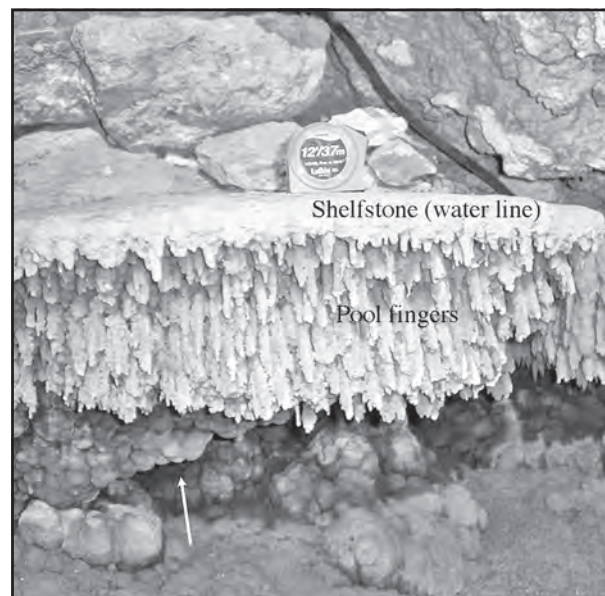

Figure 2: Pool fingers, webulite, pool meringue, and u-loops in a shallow paleopool, Lower Cave, Carlsbad Cavern. This pool started as a large pool several meters across and ≈ 30 cm deep with no biothems. The biothems formed when a later small pool, only 10 cm deep occupied the central portion. The water line visible in this image is from the second pool, the pool spar above the water line is from the earlier pool. Photo by K. Ingham.

suggesting that stagnant, or near stagnant, water is more conducive to biothem formation. Perhaps pools with active flow also have more active evaporation from agitation and therefore more abiogenic mineralization that lowers the saturation state of the pool. Alternatively, active flow may wash the microbes downstream, preventing biothem formation.

Several other factors also contribute to biothem formation including water depth, presence of an overhang (required for pendant features such as pool fingers; figure 1), and pool size or area. Some features, such as pool meringue, occur only in shallow pools (<30 cm deep) (figure 2); however, even when deeper pools have biothems, they are usually in the upper 30 cm of the pool. The average depth of biothems is 18 ± 15 cm while the average depth of all pools is $56 \pm$

64 cm. Pools with biothems average a little less, 50 ± 46 cm. This implies either a role for the air-water interface, input of nutrients, or a stratified pool. Large pools are less likely to contain biothems and when they do, the biothems are usually restricted to a small area, implying perhaps a limited nutrient supply.

A better understanding of pool conditions (e.g. depth, flow rates, area) will assist the development of microcosms to make artificial pool fingers after culturing and culture-independent (DNA) work identify the microbial communities in these pools. In addition, this understanding will be used to select the best candidates for active pool microbial sampling for culturing and DNA analyses, as part of our ongoing study of pool precipitates in the caves of the Guadalupe Mountains (BOSTON et al., 2001; MELIM et al., 2001, 2008; QUEEN and MELIM, 2006).

Acknowledgements

This material is based upon work supported by the National Science Foundation under Grants No. 0719710, 0719507 and 0719669. We thank the U.S. National Park Service for permission to work in Carlsbad Caverns National Park. In addition, special thanks are owed to USNPS employees Dale Pate, Paul Burger, and Jason Richards for their assistance during this project. A number of students participated in field work including Ginny Rust, Neil Shannon, Andy Brehm, Monica Moya, Matthew Garcia, and Cameron McMillen. Special thanks to Kenneth Ingham who took many great photographs of pools and pool precipitates in the field.

References

- BOSTON, P.J., M.N. SPILDE, D.E. NORTHUP, L.A. MELIM, D.S. SOROKA, L.G. KLEINA, K.H. LAVOIE, L.D. HOSE, L.M. MALLORY, C.N. DAHM, L.J. CROSSEY, and R.T. SCHELBLE, (2001) Cave biosignature suites: Microbes, minerals and Mars. *Astrobiology Journal*, 1, 25–55.
- K.I. CUNNINGHAM, D.E. NORTHUP, R.M. POLLASTRO, W.G. WRIGHT, and E.J. LaROCK, (1995) Bacteria, fungi, and biokarst in Lechuguilla Cave, Carlsbad Caverns National Park, New Mexico, *Environmental Geology* 25, 2–8.
- HILL, C.A. and P. FORTI, (1997) *Cave Minerals of the World*, 2nd Edition. National Speleological Society, Huntsville, Alabama, 463 pp.
- QUEEN, J.M. and L.A. MELIM, (2006) Biothems: Biologically influenced speleothems in caves of the Guadalupe Mountains, New Mexico, USA, in W. RAATZ, L. LAND, and P. BOSTON, eds, *Caves and Karst of Southeastern New Mexico*, New Mexico Geological Society Guidebook, 57th Field Conference, pp 167–174.
- MELIM, L.A., NORTHUP, D.E., SPILDE, M.N., JONES, B., BOSTON, P.J., and BIXBY, R.J. (2008) Reticulated Filaments in Cave Pool Speleothems: Microbe or Mineral?, *Journal of Cave and Karst Studies* 70, 135–141.
- MELIM, L.A., K.M. SHINGLMAN, P.J. BOSTON, D.E. NORTHUP, M.N. SPILDE, and J.M. QUEEN, (2001) Evidence of microbial involvement in pool finger precipitation, Hidden Cave, New Mexico: *Geomicrobiology Journal* 18, 311–330.

MICROBIAL DIVERSITY FROM THE SULFIDIC KARST SPRING, ŽVEPLENICA – DOLENJA TREBUŠA, SLOVENIA

JANEZ MULEC¹, ANNETTE SUMMERS ENGEL², ANDREEA OARGA³, KAREN ROSSMASSLER⁴, BARBARA J. CAMPBELL⁴, and STANKA ŠEBELA¹

¹ Karst Research Institute, Scientific Research Centre of the Slovenian Academy of Sciences and Arts, Titov trg 2, SI-6230 Postojna, Slovenia; E-mail: janez.mulec@guest.arnes.si and sebela@zrc-sazu.si

² Department of Geology & Geophysics, Louisiana State University, Baton Rouge, Louisiana 70803 USA E-mail: aengel@lsu.edu

³ University of Nova Gorica, Vipavska 13, SI-5000 Nova Gorica, Slovenia; E-mail: dora_oarga@yahoo.com

⁴ College of Marine and Earth Science, University of Delaware, Lewes, Delaware 19958 USA E-mail: karenr@udel.edu and bjc@udel.edu

Abstract

The diversity of Bacteria and Archaea from karst-associated sulfidic springs has been the topic of intense research recently, but there has been little work done to understand eukaryotic, in particular meiofauna diversity of such habitats. In Slovenia, the sulfidic spring, Žveplenica in Dolenja Trebuša, is an ideal site to investigate total biological diversity of sulfidic springs and groundwater. Our goal was to survey the spring for novel diversity, which represents the first such investigation of sulfidic karst springs in Slovenia.

Žveplenica in Dolenja Trebuša discharges from Late Triassic dolomite, situated between the regionally important Idrija and Predjama faults. The spring discharge was constant at ~2 L/min over a one-year monitoring period, and had no detectable influence from mixing of surface waters. Average temperature was 10.4 ± 0.2 °C, with an average pH of 7.6 ± 0.2 , and specific conductance of 415.4 ± 9.1 μS/cm. Dissolved sulfide concentrations were 0.03 mmol/L, with no detectable dissolved oxygen at the spring orifice.

To assess microbial diversity, microbial mats were collected and ~600 ml of spring water was filtered to 0.2 micron. Total environmental DNA was extracted from the water and 16S rRNA gene sequence diversity was evaluated. The dominant groups were affiliated with the *Gammaproteobacteria*, specifically *Thiothrix* spp. Minor bacterial groups were highly diverse, but predominately associated with *Epsilonproteobacteria*, *Deltaproteobacteria*, *Firmicutes*, and *Bacteroidetes*.

To investigate invertebrate diversity, filtered water samples were collected and surveyed over 48 hr and 96 hr to characterize the potential flux of animals from the subsurface to the surface, as well as to gain a perspective on the total subsurface eukaryotic biomass. Five different taxonomic groups were identified from the spring and a pool ~0.5 m downstream of the orifice. The groups are Annelida-Oligochaeta, Mollusca-Gastropoda, Crustacea-Copepoda, Crustacea-Brachiopoda, and Insecta-Trichoptera. The diversity in the pool was taxonomically greater, but had fewer individuals overall. Copepods were the most abundant group recovered from the spring discharge, representing 84% of the total number of individuals recovered. Copepods belonging to the Cyclopoida and Harpacticoida were the most abundant groups during the different time intervals, at 96% and 98%, respectively. Based on discharge and collected animals it was estimated that approximately 275 L of water was able to bring one individual from the subsurface.

The results provide insight into the biodiversity of sulfidic karst groundwater habitats. Although copepods are known to colonize cave and subterranean habitats, their diversity and functional role in this sulfidic system is not well understood, as similar studies in different sulfidic springs in Slovenia have not retrieved copepods.

COMPARISON OF THREE MOONMILK CAVE HABITATS ASSOCIATED WITH TROGLOBITIC BEETLES

M.G. PAOLETTI¹, M. BEGGIO¹, A. PAMIO¹, T. GOMIERO¹, M. BRILLI², A.L. DREON¹, V. TONIELLO³,
A.S. ENGEL⁴

¹Department of Biology, Padova University, 35100 Padova, Italy

²CNR Dip. Scienze della Terra, Università la Sapienza, Roma, Italy

³Gruppo grotte, Vittorio Veneto

⁴Department of Geology & Geophysics, Louisiana State University, Baton Rouge, LA 70803 USA

This study focuses on three different hydrated secondary calcium carbonate moonmilk deposits associated with troglobitic beetles, *Cansiliella* spp. (Leptodirinae). Three caves systems were evaluated (Grotta della Foos, Vecchia Diga, and Bus della Genziana, North Eastern Italy). In Grotta della Foos, up to 8–12 specimens per m² *Cansiliella* spp. are found associated with moonmilk. Grotta della Foos moonmilk had 0.01–0.06% (w/v) organic nitrogen and 0.1–0.52% (w/v) organic carbon, and little to no chlorophyll within the moonmilk or percolating waters associated with the moonmilk, indicating limited surface-derived organic carbon in the beetle habitat. Although it is well known that *Cansiliella* spp. have modified mouth parts (hoe-shaped mandibles and spoon-shaped galeas), there has not been thorough evaluations of its food source. We hypothesized that the mouth parts represent adaptations to browsing the moonmilk, and specifically feeding on microbes incorporated within the moonmilk structure. Observations of beetles from Grotta della Foos confirm that moonmilk fragments are ingested. The possibility of moonmilk-based foodwebs may offer some insight into mechanisms that have dictated novel troglobitic adaptations in nutrient-limited conditions.

1. Introduction

Cave and karst habitats are generally characterized as having limited amounts of food for troglobitic invertebrates, due in part to hydrological isolation that restricts the influx of surface-derived organic matter. An interesting troglobitic beetle, *Cansiliella* spp., is found in three caves in north-eastern Italy (Grotta della Foos, Vecchia Diga, and Bus della Genziana) (Gasparo, 1971). These beetles have been previously described to have peculiar, semi-aquatic feeding behavior and body characteristics that differ greatly from

the majority of other troglobitic Leptodirinae, including a feeding apparatus with distinct mandibles, galeas, and distinct short apical labial article shapes (Paoletti, 1973; 1980; Piva, 2000) (Fig. 1). Based on the habitat locations, and our observations of beetles browsing the moonmilk, we hypothesize that the beetles consume microbes within the moonmilk and at the moonmilk-water interface, otherwise known as the cave hygropetric habitat (Sket, 2004).



Figure 1: *Cansiliella servadeii* on hydrated moonmilk in Grotta della Foos cave, Italy. The beetle is approximately 2.8 mm long.

Vecchia Diga Cave and Genziana Cave contain *Cansiliella tonielloi*, but most of our research to date has been in Grotta della Foos where we found *Cansiliella servadeii* (Paoletti et al., 2009). Microbial biomass from the Grotta della Foos moonmilk was estimated to be $\sim 10^8$ microbial cells/ml and $\sim 10^4$ micro- and meiofaunal individuals per m², suggesting significant standing stock (Engel et al., 2009). The bacterial diversity of the moonmilk was evaluated by screening 16S rRNA gene sequence clone libraries. The majority of clones were affiliated with the *Proteobacteria* phylum (57%), among which the *Betaproteobacteria* class (26%) dominated, followed by the *Bacteroidetes/Chlorobi* (34%), and rarer sequences (<10% total of all clones, and in order of decreasing relative abundance) represented by the candidate division TM7, *Planctomycetales*, *Verrucomicrobia*, *Acidobacteria*, *Actinomycetes*, *Firmicutes*, *Nitrospirae*, and

the candidate division WS3. Some of these microbial groups have not been identified from cave or karst habitats and consequently their roles in the moonmilk system are not known. The purpose of the current investigation was to compare the moonmilk and habitat geochemistry of the three beetle cave habitats to begin to evaluate possible foodweb interactions.

2. Materials and Methods

The beetles were filmed using digital and video cameras to assess movements and feeding modalities and to document foraging and feeding behavior. Moonmilk samples and associated water were collected aseptically from each of the caves and maintained at 4°C. Water samples were filtered to 0.2 µm and analyzed for major ions, pH, temperature, and other parameters were measured immediately in the cave (Table 1). Unprepared and hydrated moonmilk samples were examined using a Philips XL30 ESEM® TMP environmental (E)- scanning electron microscope (SEM) under water vapor conditions were normally at 5°C at 4.5 to 6.5 Torr in the instrumental chamber. The ESEM was capable of X-ray fluorescence (XRF), induced by the electron primary beam and detected in Energy Dispersive Spectroscopy (EDS) mode. *Cansiliella* spp. individuals were analyzed with SEM. Samples were either air-dried

or washed in alcohol and covered with a thin gold layer. ESEM observations of the invertebrates were also done by mounting them on a thermoregulated holder.

3. Results and Discussion

Cansiliella spp. were associated with moonmilk deposits in all caves, and individuals were observed under 2-8 mm of percolating water flowing over the moonmilk. *Cansiliella* spp. were not seen on bare limestone in any system, although the moonmilk in Genziana Cave was markedly thinner and patchier than the moonmilk from the other caves. Moonmilk had a marzipan-like structure from Grotta della Foos and Vecchia Diga, and the associated waters had comparable geochemistry (Table 1). The water entering into the moonmilk area of Genziana cave, which is located at a higher elevation than the other two caves, had lower pH and temperature and higher dissolved chloride and sodium concentrations (Table 1). In fact, the Genziana moonmilk appeared to be in a state of erosion rather than deposition, which may be due to the higher Na-Cl levels. Despite the slight differences in water composition, the moonmilk in the three caves had essentially the same elemental composition from XRF analyses, although there was a slightly elevated silica concentration in the Vecchia Diga moonmilk (Table 2).

		Grotta della Foos	Vecchia Diga	Genziana
Date		3/3/2008	1/10/2009	1/24/2009
Entrance height	m	422	483	1020
Air temp	°C	8.6	7.3	6.2
Water temp	°C	8.8	8.8	7
pH		8.25	8.21	7.89
Dissolved oxygen	mg/L	10.8	8.8	7.87
Relative humidity		100%	100%	100%
Conductivity	µS/cm	225	194.7	390
Na ⁺	mg/L	0.2	0.6	25.5
K ⁺	mg/L	>0.05	<0.1	0.3
NH ₄ ⁺	mg/L	0.3	<0.05	<0.05
Ca ²⁺	mg/L	45.2	37.8	46
Mg ²⁺	mg/L	>0.05	1.6	1
Cl ⁻	mg/L	1.2	0.8	58.6
HCO ₃ ⁻	mg/L	149.5	137	131.8
NO ₂ ⁻	mg/L	0.3	<0.05	<0.05
NO ₃ ⁻	mg/L	4.5	5.6	4
PO ₄ ²⁻	mg/L	0.2	<0.05	<0.05
SO ₄ ²⁻	mg/L	3.5	1.8	2.7

Table 1: Physicochemistry of percolating waters from the three study caves.

When *Cansiliella* spp. were found associated with the moonmilk, or within the percolating waters, their mouth parts were engaged against the moonmilk, so much so, in some instances, that physical disruption of the moonmilk surface could be seen. From Grotta della Foos, moonmilk particles were observed in the beetle mouth (Fig. 2). Microbial cells, and predominately filamentous cells, were observed to be an integral component of the moonmilk (Fig. 3). The role of filaments has been previously considered essential to moonmilk formation (e.g., Borsato et al., 2000).

	Grotta della Foos	Vecchia Diga	Genziana
	wt %	wt %	wt %
C	14.9	15.38	14.13
O	38.57	43.28	41.5
Mg	0.38	0.82	0.43
Al	1.94	3.97	1.47
Si	2.57	5.33	2.72
P	0.92	BDL	BDL
S	0.95	BDL	BDL
K	0.5	0.76	0.47
Ca	39.16	28.66	38.26
Fe	1.99	1.8	1.02

Table 2: Elemental composition (in weight percent) of moonmilk by XRF. BDL = below detection limit.

Grotta della Foos presents the ideal conditions for moonmilk accumulation (Borsato et al., 2000), and likely also the microbial communities to support the high occurrence of *Cansiliella* spp. (mean of 3.8 specimens/m² on five different carbonate surfaces). The other two caves, due to the low water flow or due

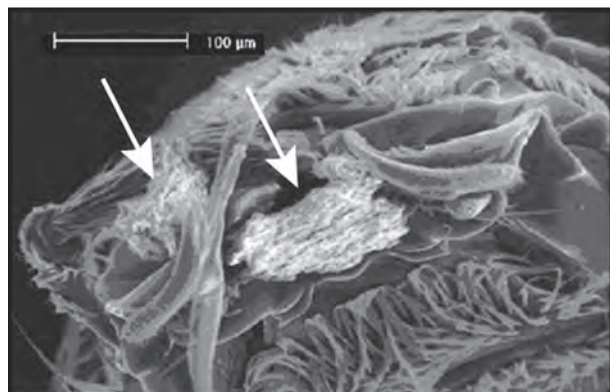
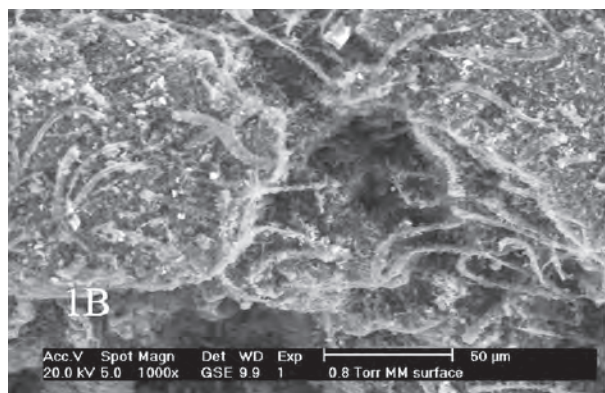

Figure 2: Arrows point to carbonate particles in the mouth parts of *C. servadeii* from Grotta della Foos cave, Italy.



to elevate presence of extraneous ions, do not present the better conditions to support the fragile presence of *Cansiliella*.

References

BORSATO, A., S. FRISIA, B. JONES, and K. VAN DER BORG, 2000, Calcite moonmilk: crystal morphology and environment of formation in caves in the Italian Alps: *Journal of Sedimentary Research*, vol. 70, pp 1179–1190.

ENGEL, A.S., M.G. PAOLETTI, M. BEGGIO, L. DORIGO, A. PAMIO, T. GOMIERO, C. FURLAN, M. BRILLI, R. BERTONI, and A.L. DREON, 2009. Microbial communities from secondary carbonate (moonmilk) deposits: the base of a cave hygropetric food web?: *Environmental Microbiology*. (In review)

GASPARO, F., 1971 La grotta della Foos presso Campone (Prealpi Carniche): *Mondo Sotterraneo*, vol 1, pp 37–52.

PAOLETTI, M.G., 1973, Notizie sistematiche ed ecologiche su di un nuovo interessante genere del Consiglio *Cansiliella*: *Suppl. Boll. Mus. Civ.S. Nat. Venezia*, vol 24, pp 81–88.

PAOLETTI, M.G., 1980, Dati aggiuntivi alla conoscenza del genere *Cansiliella* Paoletti (Col. Bathysciinae): *Redia*, Firenze, vol 63, pp 67–80.

PAOLETTI, M.G., A.S. ENGEL, M. BEGGIO, A. PAMIO, T. GOMERIO, M. BRILLI, and A.L. DREON, 2009, Moonmilk as a possible food source for the cave beetle *Cansiliella servadeii* (Leiodidae: Leptodirinae): *Journal of Cave and Karst Studies*.

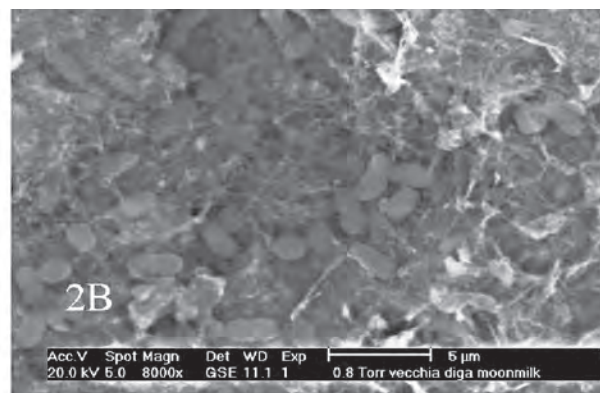

Figure 3: SEM photomicrographs of microbial cells intermixed with carbonate minerals from moonmilk in Grotta della Foos (1B), microbial cells from the moonmilk-water interface in Grotta della Vecchia Diga (2B).

PIVA, E., 2000, Contributo alla conoscenza del genere Cansiliella, con descrizione di una nuova specie. (Col. Cholevidae), Boll. Soc. Entomol. Ital., vol 132, pp 123–134

SKET, B., 2004, The cave hygropetric – a little known habitat and its inhabitants: Arch. Hydrobiol., vol 160, pp 413–425.

ENERGY FLOW AND PRODUCTIVITY-DIVERSITY RELATIONSHIPS IN CHEMOLITHOAUTOTROPHICALLY-BASED ECOSYSTEMS

MEGAN L. PORTER¹, ANNETTE SUMMERS ENGEL²

¹Department of Biological Sciences, University of Maryland at Baltimore County, Baltimore, Maryland 21250, USA; porter@umbc.edu

²Department of Geology & Geophysics, Louisiana State University, Baton Rouge, Louisiana 70803, USA; aengel@geol.lsu.edu

Extended Abstract

There have been relatively few studies delineating energy flow in cave and karst systems, and even fewer investigations of ecosystem energetics from solely chemolithoautotrophically-based ecosystems. One outstanding question is related to how such ecosystems are energetically sustained. Compared to the deep subsurface or hydrothermal vents, caves allow for easy access to chemolithoautotrophic microbial processes where energetics can be directly investigated. This research focuses on productivity-diversity relationships within the context of varying geochemical conditions in karst ecosystems.

We sampled four active sulfidic caves (Movile Cave, Romania; Frasassi Caves, Italy; Lower Kane Cave, Wyoming, USA; and Cesspool Cave, Virginia, USA). Water samples were collected using standard methods for major and trace ion concentrations, and physicochemistry was measured at each site, including temperature, pH, conductivity, dissolved oxygen, alkalinity, and sulfide concentrations. Microbial mats were aseptically sampled. Radiotracer techniques, including ¹⁴C-bicarbonate to measure chemolithoautotrophy, ¹⁴C-leucine for heterotrophy, and ¹⁴C-acetate for chemoorganotrophy, were used to determine the productivity of each cave community. The diversity of each microbial community was estimated using 16S rRNA clone libraries. Operational taxonomic units (OTUs) were determined at 99% sequence similarity for each library using the program DOTUR (Schloss and Handelsman 2005). The potential energies for reactions representing possible chemolithoautotrophic metabolic pathways were determined from the activities of metabolic reactants and reaction products, as defined by mass-action relations for the moles of each dissolved ion in the cave system, generated from the program PHREEQC Interactive (Parkhurst and Appelo 1999). Standard free energies (ΔG_R°) for redox reactions associated with chemolithoautotrophy were calculated, and ΔG_R was determined from the equation, $\Delta G_R = \Delta G_R^\circ + RT \ln Q$, where Q is the activity quotient of the measured species.

The microbial diversity in all four caves was unique, as overall community compositions were significantly different from each other ($P \leq 0.001$). Only 13% of the novel OTUs were found in more than one cave; none of the OTUs were identified in all four caves sampled. The highest primary productivity rates were from Movile Cave, at $4.72 \pm 0.78 \mu\text{g C/mg dry weight/hr}$ (Fig. 1), and heterotrophic productivity was at least one order of magnitude less than autotrophy in all caves. Autotrophic productivity was positively correlated to overall species richness ($R^2 = 0.62$;

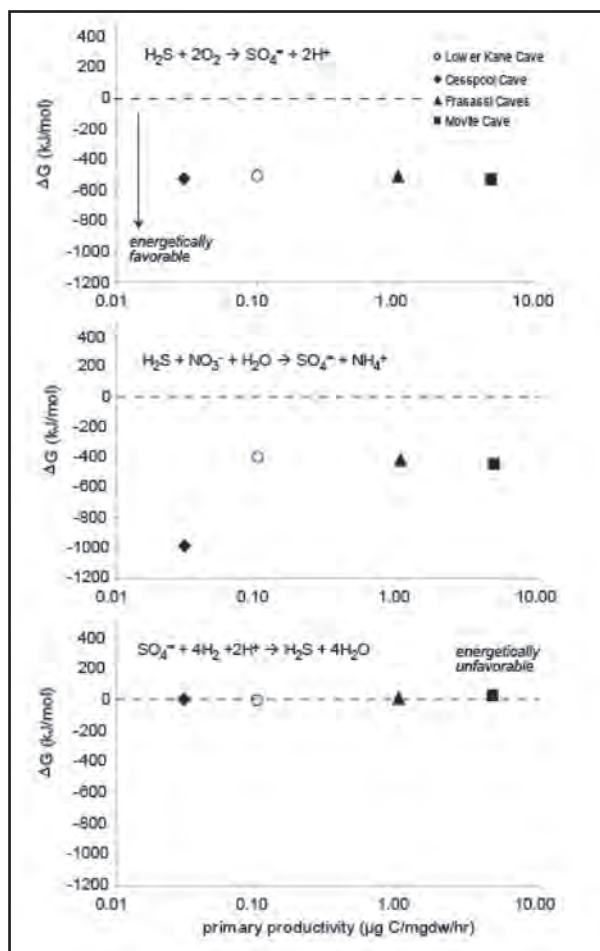

Figure 1: Free energies of various redox reactions.

$P \leq 0.03$) and to several bacterial OTUs affiliated with the *Epsilonproteobacteria* ($R^2 = 0.70$; $P \leq 0.05$), a group of microbes associated with sulfide oxidation using oxygen or nitrate. Dissolved sulfide concentrations ranged from 39 $\mu\text{mol/L}$ (Lower Kane Cave) to 240 $\mu\text{mol/L}$ (Movile Cave), and higher rates of autotrophy were strongly positively correlated to dissolved sulfide ($R^2 = 0.93$; $P \leq 0.04$). From ΔG_R calculations, the most energetic pathways for all caves were associated with sulfide oxidation, using both NO_3^- or O_2 (Fig. 1) In contrast, although *Deltaproteobacteria* associated with sulfate reduction were identified from 16S rRNA gene sequences, this pathway is not energetically favorable (Fig. 1). Because primary productivity rates are crucial for ecosystem dynamics, higher trophic level diversity (e.g. macroinvertebrates) should be greatest when microbial productivity is high enough to sustain ecosystem level processes.

References

- Parkhurst, D.L. and C.A.J. Appelo (1999) User's guide to PHREEQC (version 2) – a computer program for speciation, batch-reaction, one-dimensional transport, and inverse geochemical calculations. In *Water-Resources Investigations Report*. USGS, 312 pp.
- Schloss, P.D. and J. Handelsman (2005) Introducing DOTUR, a computer program for defining operational taxonomic units and estimating species richness. *Applied and Environmental Microbiology* 71:1501–1506.

MICROORGANISMS INVOLVED IN THE FORMATION AND DISSOLUTION OF CARBONATE DEPOSITS IN SPANISH CAVES

M.C. PORTILLO¹, E. PORCA¹, S. CUEZVA², S. SANCHEZ-MORAL², and J. M. GONZALEZ¹

¹IRNAS-CSIC, Avda. Reina Mercedes 10, 41012 - Seville, Spain

²National Museum of Natural Sciences, MNCN-CSIC, Jose Gutierrez Abascal 2, 28006 - Madrid, Spain

Microorganisms play critical roles in biogeochemical processes. In caves, carbonate deposition constitutes a common process. Although microorganisms able to induce these deposits have been previously reported, little information is available on the microorganisms involved, their activity, and the conditions required for the process to occur. This study presents results on the induction of carbonate precipitation and dissolution by microorganisms. RNA-based molecular fingerprinting procedures were used for profiling the metabolically active bacterial communities involved in the preliminary stages of moonmilk deposits. Bacteria were cultured and isolated to analyze the required conditions and nutrients inducing these depositions. Bacteria were able to differentially induce carbonate precipitation depending on the nutrients available for growth. In addition, similar microorganisms can be involved in precipitation and dissolution of carbonates mainly depending on the available nutrient sources. These results suggest the existence of an active carbon cycling process in caves dominated by microorganisms.

1. Introduction

The role of microorganisms in shaping the geology of our planet has been a topic of investigation for many years. Biomineralization in cave environments is one of the scenarios where microorganisms have been reported to actively participate (Cañaveras et al. 2006; Barton & Northup, 2007). The case of moonmilk formation, a soft, wet, fine-grained secondary cave deposit constituted mainly of carbonates, has been suggested to be induced by microbial metabolism (Barton & Northup, 2007). Recent reports point to the active role of bacteria as the most common microbial type participating in these depositions (Cañaveras et al., 2006).

While bacteria are considered as the major inducers of carbonate deposits, little information is available concerning the conditions and mechanisms leading to the accumulation of these precipitates in caves. Carbonates precipitate at alkaline pH (pH > 8) according to the well studied CO₂-carbonate equilibrium in natural systems. Consequently, any increase of pH (above pH 8) generated as a result of bacterial metabolism could lead to carbonate precipitates. In a similar way, pH decreases as a result of bacterial metabolism might lead to carbonate dissolution since then CO₂-carbonate equilibrium is altered towards the CO₂-carbonic acid soluble forms. Thus, microorganisms can directly influence both precipitation and dissolution of carbonates.

The aim of this study is to provide some evidence leading to

an understanding of the role microorganisms on carbonate deposition and dissolution and the conditions required for each of these two processes to occur.

2. Materials and Methods

Moonmilk deposits were sampled from different spots along Altamira Cave (Cantabria, North Spain). Samples were collected aseptically using sterilized instruments, maintained on ice during transportation and processed as soon as possible upon arrival at the laboratory.

Bacterial communities were analyzed by RNA-based molecular methods as previously described (Gonzalez et al. 2003; Portillo & Gonzalez, 2008). Bacteria were isolated using Nutrient Agar at 28° C. The effect on pH as a function of different supplied nutrients was studied in a medium base composed of 0.4 g l⁻¹ peptone per liter. Base liquid medium was supplemented with 1.6 g l⁻¹ of one of the following: glucose, calcium or sodium acetate, sodium oxalate, casein, and ammonium chloride. Visual inspection of the formation of carbonate precipitation or dissolution during bacterial growth on solid media (15 g l⁻¹ agar) was carried out at 10x using a stereomicroscope.

The semiquantitative mineral composition of crystals formed during bacterial growth was determined by X-ray diffraction (XRD) with a Philips PW-1710 and examined using a Philips Quanta 200 environmental scanning electron microscope (ESEM).

3. Results and Discussion

Bacterial isolates belonging to the major bacterial groups constituting the bacterial communities in the studied cave environment were obtained. These communities were studied through RNA-based molecular survey and DGGE analyses. Results showed that most bacterial isolates tested induced the highest pH conditions by consuming acetate while the lowest pH conditions were induced when highly rich nutrients were consumed (i.e., glucose) (Fig. 1). Growth on protein-rich nutrients (peptone, casein) resulted in moderate pH increases suggesting that ammonia production from protein consumption could be an alternative route inducing carbonate precipitation. The source of calcium to form calcium carbonate deposits is irrelevant since either calcium acetate or calcium chloride leads to similar amounts of precipitates. Lower temperature resulted in a slowing down of the metabolic rate, but similar effects of nutrients on pH were observed at different temperatures. Low molecular weight organic acids, such as acetate, are the final metabolic products of heterotrophic bacterial metabolism (Madigan et al., 2003). These are produced during the degradation of complex organic compounds usually available in cave environments. Drastic pH changes provided by bacterial metabolism can easily result in values above pH 8 which is adequate for carbonate precipitation.

Acknowledgments

This research was supported by CGL2006-11561/BTE project. All Altamira Cave Research Centre and Museum

staff are acknowledged for their collaboration throughout the whole research period.

References

- Barton, H.A. and D.E. Northup (2007). Geomicrobiology in cave environments: past, current and future perspectives. *Journal of Cave and Karst Studies* **69**: 163–178.
- Cañaveras J.C., S. Cuezva, S. Sanchez-Moral, J. Lario, L. Laiz, J.M. Gonzalez, and C. Saiz-Jimenez (2006). On the origin of fiber calcite crystals in moonmilk deposits. *Naturwissenschaften* **93**: 27–32.
- Gonzalez, J.M., A. Ortiz-Martinez, M.A. Gonzalez-delValle, L.C. Laiz, and C. Saiz-Jimenez, (2003). An efficient strategy for screening large cloned libraries of amplified 16S rDNA sequences from complex environmental communities. *Journal of Microbiological Methods* **55**: 459–463.
- Madigan M., J. Martinko and J. Parker (2003). Brock Biology of Microorganisms. Prentice Hall, Inc. New Jersey, USA.
- Portillo M.C. and J.M. Gonzalez (2008). Statistical differences between molecular fingerprints from microbial communities. *Antonie van Leeuwenhoek* **94**: 157–163.

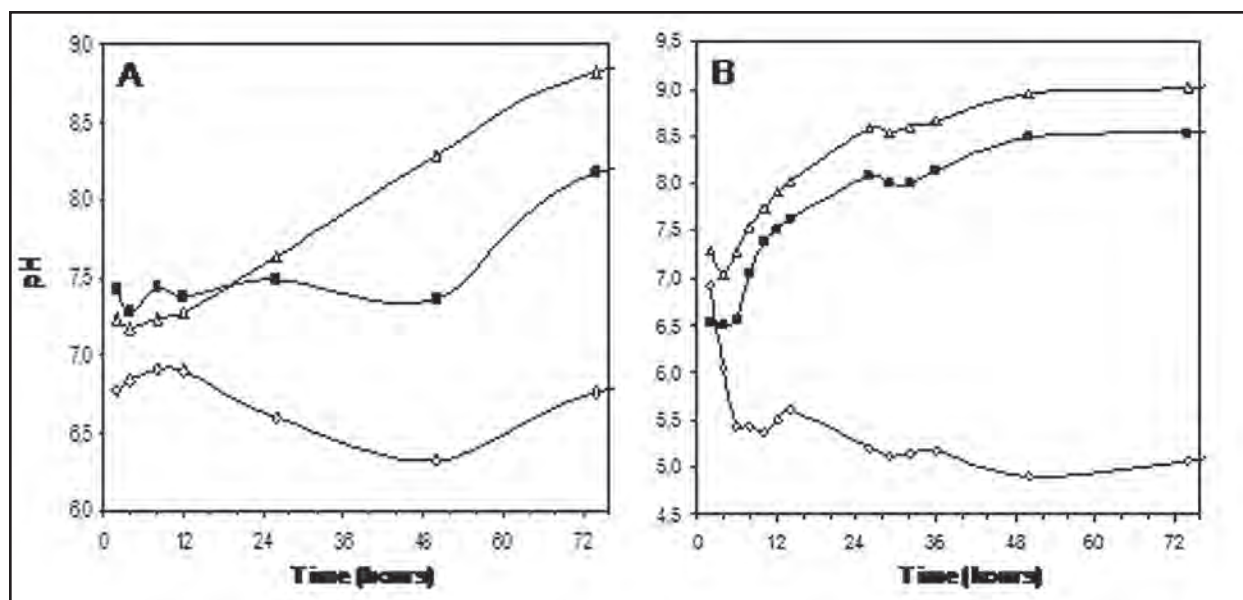

Figure 1: Changes in pH during growth on different nutrients of two bacterial isolates from Altamira Cave. A, an Alphaproteobacterium, *Sphingomonas*; B, a Firmicutes, *Bacillus*. Dark squares correspond to the base medium containing peptone as the only carbon source; open triangles correspond to base medium supplemented with acetate; open diamonds correspond to base medium supplemented with glucose.

AN AUTONOMOUS ROBOTIC EXPLORATION OF DEEP PHREATIC SINKHOLES REVEALS A WEALTH OF MICROBIAL DIVERSITY

JASON W. SAHL¹, J. KIRK HARRIS³, MARCUS O. GARY², BILL STONE⁴, JOHN R. SPEAR¹

¹*Division of Environmental Science and Engineering, Colorado School of Mines, Golden, Colorado, 80401*

²*Department of geological sciences, University of Texas, Austin, Texas*

³*Molecular, cellular, and developmental biology, University of Colorado, Boulder, Colorado*

⁴*Stone Aerospace, Del Valle, Texas, 78617*

Extended Abstract

In spring of 2007, the deep phreatic thermal explorer (DEPTHX), an autonomous underwater vehicle, explored several phreatic limestone sinkholes (cenotes) in Northeastern Mexico as part of a NASA funded project to one day search for extraterrestrial microbial life. During dive missions in the cenote, the vehicle collected water column and biomat samples at a range of depths and aspects. Samples were returned to the surface, collected, DNA was extracted from each sample, and a molecular survey of the microbial community present was conducted using 16S rRNA gene analysis. Further analysis on extracted DNA samples was carried out with a barcoded amplicon pyrosequencing approach (Hamady *et al.*, 2008) to reveal higher resolution microbial community structure information.

Water geochemistry obtained by both on-board sensors and post-operation analyses suggests that each of the cenotes is extremely well mixed. Several abiotic parameters such as temperature and pH are identical throughout the 300 m water column of the deepest cenote (Zacatón). When chemistries were compared between Zacatón, the

deepest phreatic sinkhole in the world, and neighboring La Pilita, small but statistically significant differences were observed. Visual observations of the filterable microbial fraction from the cenotes suggested that differences in microbial composition were present in cenotes in close geographical proximity with related water chemistry. Comparative molecular analyses of water column microbial communities showed clear differences between Zacatón, La Pilita, and Caracol. Typically, in comparative microbial studies, a hypothesis test concerning community similarity is conducted and a P value is evaluated. In many cases, a significant P value only shows that the bulk community structure between samples is different and reveals nothing about the underlying community substructure. In this study, pyrosequences from each cenote were processed with the ribosomal database project (RDP) pyrosequencing pipeline (Cole *et al.*, 2008), and further characterized by the Greengenes classifier (DeSantis *et al.*, 2006). High resolution taxonomic information helped to differentiate samples with similar phylum-level characterizations. For example, the microbial community was surveyed in three cenotes

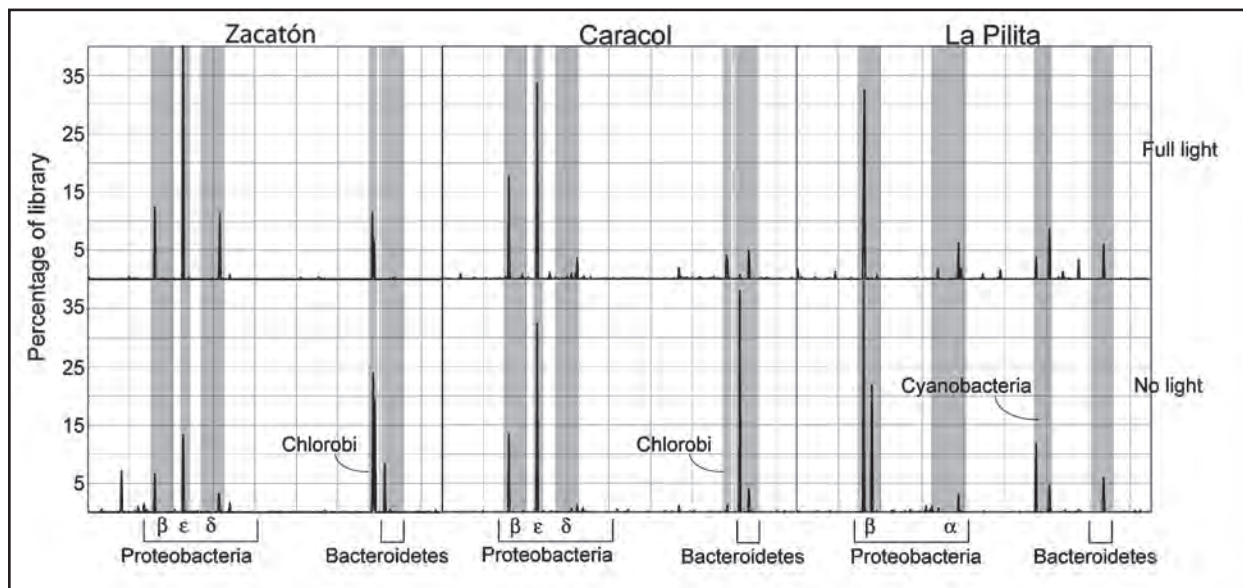

Figure 1.

from the filterable fraction of the water from the surface and at the photic zone floor where the photosynthetically active radiation (PAR) readings were no longer detectable. When the operational taxonomic unit (OTU) distribution signatures were compared between cenotes, clear differences in the distribution and composition of specific microbial lineages was observed (Fig. 1).

Wall biomat samples from all samples harbored novel microbial diversity. An initial survey of microbial diversity showed novel phylum-level lineages in deeper regions of the cenotes. Phylogenetic analysis, combined with quantitative PCR, revealed the relative abundance and presence of three well-supported candidate divisions. In general, below 30 meters in La Pilita and Zacatón, the community was dominated by a novel clade of Deltaproteobacteria and a diverse assemblage of Chloroflexi. Some archaeal sequences grouped with known methanogens, but the vast majority grouped with the C2 Crenarchaeota; this clade has been associated with freshwater sediments and hydrothermal environments. Similar types of microbes were shared between wall biomat samples in Zacatón and La Pilita, but clear differences were also observed. Corresponding differences were also observed in the elemental composition of extractable wall biomat material between cenotes.

A metagenomics sequencing run, using the new 454 titanium platform, revealed dominant metabolic pathways in a low diversity sample. The water column of cenote El Zacatón, which is dominated by Epsilonproteobacteria, showed low microbial diversity, which is ideal for metagenomic sequencing and assembly. The majority of metagenomic metabolic sequences showed homology with genes necessary for carbohydrate metabolism. These results suggest that microbes in the water column are metabolizing photosynthate released by the extensive phototrophic microbial mats in the photic zone of the cenote.

The presence of lineages associated with anoxic metabolism focused a directed functional gene search. Genes associated

with anaerobic ammonium oxidation, hydrogen production and/or uptake, methanogenesis, sulfate reduction, and inorganic carbon fixation were successfully amplified, cloned, and sequenced from the walls of Zacatón and La Pilita. In general, these gene sequences showed low identity to sequences in public database repositories and very low relatedness to cultured representatives.

In general, the results of this study show extensive microbial diversity in Mexican cenotes from all three domains of life. The anoxic nature of the cenotes select for metabolic processes such as methanogenesis and sulfate reduction. The barcoded amplicon strategy employed allows for a deeper understanding of the microbial diversity in Mexican cenotes and how microbial communities can change due to small, but significant differences in geochemistry.

References

- Cole, J.R., Q. Wang, E. Cardenas, J. Fish, B. Chai, R.J. Farris, A.S. Kulam-Syed-Mohideen, D.M. McGarrell, T. Marsh, G.M. Garrity, and J.M. Tiedje (2008). "The Ribosomal Database Project: improved alignments and new tools for rRNA analysis." *Nucleic Acids Res* doi:10.1093/nar/gkn879: 1–5.
- DeSantis, T.Z., P. Hugenholtz, N. Larsen, M. Rojas, E.L. Brodie, K. Keller, T. Huber, D. Dalevi, P. Hu, and G.L. Andersen (2006). "Greengenes, a chimera-checked 16S rRNA gene database and workbench compatible with ARB." *Appl. Environ. Microbiol.* 72(7): 5069–5072.
- Hamady, M., J.J. Walker, J.K. Harris, N.J. Gold, and R. Knight (2008). "Error-correcting barcoded primers for pyrosequencing hundreds of samples in multiplex." *Nat. Meth.* 5: 235–237.

THE CONTROL OF A FUNGAL OUTBREAK IN A SHOW CAVE

CESAREO SAIZ-JIMENEZ¹, VALME JURADO¹, ESTEFANIA PORCA¹, SOLEDAD CUEZVA², ANGEL FERNANDEZ-CORTES², and SERGIO SANCHEZ-MORAL²

¹Instituto de Recursos Naturales y Agrobiología, CSIC, Apartado 1052, 41080 Sevilla, Spain

²Museo Nacional de Ciencias Naturales, CSIC, 28006 Madrid, Spain

Castañar de Ibor Cave (Spain) is a low energy cave with very high microenvironmental stability throughout the annual cycle and minimum rates of energy exchange with the atmosphere. This show cave was discovered in 1967 and declared a Natural Monument in 1997. Later in 2003 the cave was opened to public visits. On 26 August 2008, the cave walls and soils appeared colonized by long, white fungal mycelia. This event was the result of an accidental input of organic matter on the afternoon of 24 August 2008. The outbreak was initiated by *Mucor circinelloides* and *Fusarium solani*.

1. Introduction

In recent years, European caves have been suffering episodes of biological contamination that threaten the conservation of these geological and cultural heritage sites. Until now, there was no direct evidence on the causes of fungal contamination in caves, such as those that occurred in 2001 in Lascaux Cave, France, after a heavy fungal outbreak (BASTIAN AND ALABOUVETTE, 2009). Opening of a cave to visitors represents a strong and often irreversible impact on the whole ecosystem. Bacteria, fungi, arthropods, etc. have constructed delicate and balanced trophic relationships in caves, which are frequently interrupted by major environmental changes as a consequence of visits. These changes include concrete stairs, air conditioning (BASTIAN et al., 2009) and elevators, etc., which are some of the examples of changes found in European caves.

Castañar de Ibor (Caceres, Spain) is defined as a 'low energy' cave showing very high micro-environmental stability throughout the annual cycle, under natural conditions (LARIO et al., 2006). This large microclimatic stability is a basic characteristic of karst systems and causes a high sensitivity by the ecosystem to changes in environmental conditions, such as temperature and anthropic activities. Therefore, in 2003, a strict control was established for visitors. For instance, during 2007 only 1,010 people accessed the cave with a maximum quota of 5 visitors per group and an average stay of 65 minutes.

2. Cave Microbiology

On the afternoon of August 24, 2008, accidental vomiting by a visitor led to the input of detritus into Castañar de Ibor Cave. The effects of this impact were not observed until August 26, 2008, when cave walls and soil demonstrated long, white fungal mycelia. On September 4, three samples were obtained from the disturbed area, with additional

sampling on September 11 and October 28, 2008.

The fungal outbreak in the cave coincided with the period of greatest air exchange between the cave and the outer atmosphere. During summer (from June to October) the exterior air temperature is constantly above the cave air temperature. The external relative humidity falls below 60% and registered rainfall represents 33.4% of the annual total over a period of 130 days. These factors provoke underground air renewal and, therefore, the dispersion of fungi in the cavity.

From 20 samples collected from the cave, all of them showing fungal growth, we have retrieved a total of 26 isolates (Table 1). While 10-20 days after the event, only two fungi were identified: *Mucor circinelloides* and *Fusarium solani*, representing up to 75 and 25 % of the isolates, they decreased to 13 and 7 % two months after the outbreak. These two fungi behaved as "r" strategists (FRANKLAND, 1992), and were able to occupy the habitat rapidly with explosive rates of reproduction. *Mucor circinelloides* produces long hyphae, with a fluffy appearance, that can grow to a height of several cm. This fungus is common in caves, and colonizes animal feces and insects (NOVÁKOVÁ, 2009).

Spores disseminated by rodent feces and insects - also observed in this cave - germinated rapidly in response to available nutrients. *Fusarium solani* is also frequently found in caves (JURADO et al., 2008). Members of the *Fusarium solani* are ubiquitous plant pathogens and saprotrophs. This was also the fungus found invading Lascaux Cave in 2001 (BASTIAN AND ALABOUVETTE, 2009) and the Takamatsuzuka and Kitora Tumuli in Japan (KIYUNA, 2008).

Fungal successions on decomposing organic matter are

	September 4, 2008	September 11, 2008	October 28, 2008
Number of samples	3	7	10
Number of isolates	3	8	15
<i>Mucor circinelloides</i>	2	6	2
<i>Fusarium solani</i>	1	2	1
<i>Mucor racemosus</i>	-	-	1
<i>Fusarium oxysporum</i>	-	-	2
<i>Chaetomium globosum</i>	-	-	1
<i>Mortierella alpina</i>	-	-	1
<i>Hypocrea lixii</i>	-	-	1
<i>Aspergillus ustus</i>	-	-	2
<i>Paecilomyces lilacinus</i>	-	-	1
<i>Cosmospora consors</i>	-	-	1
<i>Penicillium</i> sp.	-	-	2

Table 1.: Fungi identified in the outbreak of Castañar de Ibor Cave.

rarely followed to an end-point. In this case, it was possible to follow the fungal succession in the cave and to identify secondary colonizers. In fact, other fungi such as *Fusarium oxysporum*, *Chaetomium globosum*, *Mortierella alpina*, *Hypocrea lixii*, *Aspergillus ustus*, *Paecilomyces lilacinus*, *Cosmospora consors* and a *Penicillium* sp. were isolated two months after the disturbance event from small white spots in the soil. Most of these fungi are necrotrophic, which are characterized by their ability to use dead plant or animal tissues as a source of nutrients. Some others have been reported to be entomopathogens (i.e. disease agents in insects), such as *M. circinelloides*, *F. solani*, *F. oxysporum*, and *Paecilomyces lilacinus* (HUMBER AND HANSEN, 2005).

Treatments to stop the fungal outbreak in Castañar de Ibor Cave included a careful mechanical removal of a few cm of the polluted top sediment and sterilization of the underlying materials with commercial hydrogen peroxide (FAIMON et al., 2003). The treatment was repeated when necessary, and after the initial outbreak the cave only presented scattered white colonizations that appeared from time to time along the visitor trail as well as some colonized rodent feces. These small spots were likely due to the detritus transported inside by former visitor footsteps. No colonizations were observed in the sediment of non-visited halls and galleries, other than in some rodent feces. Therefore, it appears that the strategy to control the outbreak was successful.

This study provided evidence of the fragility of show caves and demonstrated that visits may compromise conservation. This raises an intriguing question: Should rock art caves be subjected to the ravages of visits or should they be protected from significant visitation and associated disturbance events,

as in the case of some French caves that have never been open to public visits?

Acknowledgements

The authors acknowledge support from the Ministry of Education, Spain, project CGL2006-07424/BOS, CGL2006-11561/BTE, and Junta de Extremadura. This is a TCP CSD2007-00058 paper. The collaboration of Ana Blazquez, cave guide, is highly appreciated.

References

- BASTIAN, F. and C. ALABOUVETTE (2009) Lights and shadows on the conservation of a rock art cave: The case of Lascaux Cave. *International Journal of Speleology* **38**, 55–60.
- BASTIAN, F., C. ALABOUVETTE, and C. SAIZ-JIMENEZ (2009) Bacteria and free-living amoeba in Lascaux Cave. *Research in Microbiology* **160**, 38–40.
- FAIMON, J., J. STELCL, S. KUBESOVÁ, and J. ZIMÁK (2003) Environmentally acceptable effect of hydrogen peroxide on cave “lamp-flora”, calcite speleothems and limestones. *Environ. Poll.* **122**, 417–422.
- FRANKLAND, J.C. (1992) Mechanisms in fungal succession. In: *The Fungal Community. Its Organization and Role in the Ecosystem*. G.C. Carroll and D.T. Wicklow (eds.), Marcel Dekker New York, pp 383–401.

- HUMBER, R.A. and K.S. HANSEN (2005) *ARSEF Index: Host-by-fungus*. USDA-ARS Collection of Entomopathogenic Fungal Cultures, Ithaca, NY.
- JURADO, V., S. SANCHEZ-MORAL, and C. SAIZ-JIMENEZ (2008) Entomogenous fungi and the conservation of the cultural heritage. A review. *International Biodeterioration and Biodegradation* **62**, 325–330.
- KIYUNA, T., K-D. AN, R. KIGAWA, C. SANO, S. MIURA, and J. SUGIYAMA (2008). Mycobiota of the Takamatsuzuka and Kitora Tumuli in Japan, focusing on the molecular phylogenetic diversity of *Fusarium* and *Trichoderma*. *Mycoscience* **49**, 298–311 (2008).
- LARIO, J., S. SANCHEZ-MORAL, S. CUEZVA, M. TABORDA, and V. SOLER (2006) High ^{222}Rn levels in a show cave (Castañar de Ibor, Spain): Proposal and application of management measures to minimize the effects on guides and visitors. *Atmospheric Environment* **40**, 7395–7400.
- NOVÁKOVÁ, A. (2009) Microscopic fungi isolated from the Domica Cave system (Slovak Karst National Park, Slovakia). A review. *International Journal of Speleology* **38**, 71–82 (2009).

HOW CAN BUFFERED VADOSE AND PHREATIC WATER DISSOLVE CaCO_3 AND FORM CAVES: A BACTERIAL ANSWER

¹STEPHANIE J. SCHWABE, ²JAMES L. CAREW

¹Rob Palmer Blue Holes Foundation, 5 Longitude Lane, Charleston, SC 29401

²Department of Geology and Environmental Geosciences, College of Charleston, Charleston, SC 29424

Extended Abstract

The generally accepted view of most shallow limestone dissolution is that CO_2 in meteoric water and groundwater is controlled by the acidic pH of rainwater due to incorporated atmospheric CO_2 , plus CO_2 contributed in the near-surface (especially soil) environment; and it is these initial CO_2 concentrations that dictate the amount of limestone dissolution (WHITE, 1988). It has been assumed that once such meteoric water enters the vadose zone, additional input of meteoric water maintains its dissolution potential. It has been pointed out (e.g., WHITE, 1988) that there is a large volume of literature linking the formation of caves and the water table and that mixing of different water masses saturated, or supersaturated, with respect to CaCO_3 could produce undersaturated mixed water capable of significant dissolution of limestone (e.g., PLUMMER, 1975; BACK et al., 1986). Furthermore, dissolution often is most extensive where groundwater discharges into the sea (e.g., SANFORD AND KONIKOW, 1989; STOESELL et al., 1989).

In the 1980s, research in the Bahamas documented many large caves with phreatic dissolutional features in rocks that are only ~330,000 to 120,000 years old. Those rocks have been subjected to phreatic conditions during only one to three of the short (~10,000 years) mid-late Pleistocene glacio-eustatic highstands of sea level. So, these caves may have formed in 10,000–12,000 years, but not more than 45,000 years, of dissolution in the phreatic zone. The flank margin hypothesis of cave formation was proposed to explain how such large caves could have formed so rapidly (MYLROIE AND CAREW, 1990).

The flank margin hypothesis proposed that the rapid formation of Bahamian caves resulted from the mixing of descending meteoric (vadose) water with the fresh-brackish groundwater lens, and additional mixing with underlying seawater, particularly at the discharging margin of the groundwater lens where flow rate is greatest. Currently, the flank margin hypothesis is the only accepted explanation for the development of such caves. However, studies of the hydrogeochemistry of Bermuda (PLUMMER et al., 1976) demonstrated that calcite saturation in the mixing zone is controlled by CO_2 degassing, and not by the mixing of

freshwater with seawater. The question that has never been directly addressed is, where is all the CO_2 necessary for driving the dissolutional process coming from?

A microbial role in cave development has previously been hypothesized for a variety of sites (e.g., HILL, 1990; ENGEL et al., 2004). However, those cases involve sulfur oxidizing bacteria and H_2SO_4 . Here, we are focusing on microbes that may play a role in classical CO_2 -driven (carbonic acid) cave formation. We postulate that the dissolutional capacity of the vadose water is enhanced, or maintained, as descending water accumulates CO_2 produced by bacteria residing in the pores of the rock. In addition, bacteria in the saturated zone of the rocks (SCHWABE, 2002) also contribute CO_2 and other acids. In particular, accumulations of POC, POM, DOC, and bacterial cells, especially at density interfaces in the upper mixing zone and at the bottom of the mixing zone, produce optimal conditions where many bacteria thrive (SCHWABE, 2002). These microbes produce PCO_2 levels of at least 3–4 times atmospheric concentration. We suggest that it is the microbially-maintained acidic pH at these boundaries that is responsible for the observed greater limestone dissolution that seems to be associated with sea level (MYLROIE AND CAREW, 1988a), rather than the actual physical mixing of different water masses.

Our microbial hypothesis is supported by a variety of data obtained from our past and recent study of rocks and water in the Bahamas. Discoveries relevant to this issue include the following. Rainwater collected under sterile conditions before contact with the ground in the Bahamas contained $\sim 10^3$ bacterial cells per milliliter, and had a pH of 5.72. Within 3 minutes, pH of 4ml of rainwater exposed to 1 ml of limestone rose to 8.06. Pouring that water through soil samples resulted in pH reduction to 7.76–7.89. Those samples were again exposed to 1 ml of limestone, and pH rose to >8 within 3 minutes. Water from cave dripstones contained $>10^4$ to 10^5 cells/ml, and limestone samples from 2.5 cm deep in the wall rock of a Bahamian contained $>10^6$ viable cells per half gram of rock sample. The dominant bacteria present in these limestone

samples were aerobic heterotrophic Gram-positive bacteria of Order Actinomycetales, which produce CO₂ as an end-product of carbon metabolism. Surface and 2.5-cm-deep cave-wall-rock samples held in sealed sterile vials for 14 days yielded CO₂ contents of 770–410 ppm above current atmospheric concentration (380 ppm). In contrast, sterilized rock samples from the same sites yielded no excess CO₂. CO₂-flux-meter data revealed that a large amount of CO₂ was being released from the cave ceiling-rock, and at a rate greater than that yielded from the cave floor sediment that contains bat guano and other organics. In addition, 8-cm-deep rock cores recovered from the phreatic zone in Lucayan Caverns, Grand Bahama Island (SCHWABE et al., 1997) had bacterial counts from 1.321 x 10⁶ cells to 19,756 cells (8 cm deep into the cave wall rock), with highest counts from the top of the mixing zone. Collectively, these data indicate that bacteria living in the rock and groundwater have the potential to drive CO₂-related dissolution in the vadose and phreatic zones, and also that the porosity of the limestone may be enhanced even when the rock is not saturated with water. Drip-waters collected within the cave had δ¹³C values of -9.55‰, and δ¹³C of the CO₂ in the cave atmosphere ranged from -16.46 to -15.85‰ (D. MCGEE, 2008, pers. comm.). The quite negative δ¹³C values most likely reflect the activity of bacteria.

It is our view that limestone dissolution is not primarily the result of inorganic physico-chemical reactions and that abundant indigenous bacteria generate CO₂ that sustains dissolution. We further suggest that dissolution is greatest in the mixing zone and the upper marine section of the water column at the discharging margin of the lens where there is the greatest amount of water movement (which enhances solute removal) and the largest concentrations of bacteria. Hence, caves develop to their greatest extent, at or near sea level, which is consistent with the reported usefulness of flank margin caves as indicators of past sea level position (MYLROIE AND CAREW, 1988b), and provides a reasonable explanation for how large caves were produced so quickly.

References

- BACK, W., B.B. HANSHAW, J.S. HERMAN, and J.N.V. DRIEL (1986) Differential dissolution of a Pleistocene reef in the ground water mixing zone of coastal Yucatan, Mexico. *Geology* **4**, 137–140.
- ENGEL, A.S., L.A. STERN, and P.C. BENNETT (2004) Microbial contributions to cave formation: New insights into sulfuric acid speleogenesis. *Geology* **32**, no. 5, 369–372.
- HILL, C.A., (1990) Sulfuric acid speleogenesis of Carlsbad Cavern and its relationship to hydrocarbons, Delaware Basin, New Mexico and Texas. *American Association of Petroleum Geologists Bulletin* **74**, 1685–1694.
- MYLROIE, J.E. and J.L. CAREW (1988a) Field evidence of the minimum time for speleogenesis. *National Speleological Society of America Bulletin* **49**, 67–72.
- MYLROIE, J.E. and J.L. CAREW (1988b) Solution conduits as indicators of Late Quaternary sea level position. *Quaternary Science Reviews* **7**, 55–64.
- MYLROIE, J.E. and J.L. CAREW (1990) The flank margin model for dissolution cave development in carbonate platforms. *Earth Surface Processes and Landforms* **15**, 413–424.
- PLUMMER, L.N. (1975) Mixing of sea water with calcium carbonate ground water, in *Quantitative Studies in Geological Sciences*, E.H.T. Whitten (Ed.), Geological Society of America Memoir **142**, 219–236.
- PLUMMER, L.N., H.L. VACHER, F.T. MACKENZIE, O.P. BRICKER, and L.S. LAND (1976) Hydrogeochemistry of Bermuda: A case history of ground-water diagenesis of biocalcarenes. *Geological Society of America Bulletin* **87**, 1301–1326.
- SANFORD, W.E. and L.F. KONIKOW (1989) Porosity development in coastal carbonate aquifers. *Geology* **17**, 249–252.
- SCHWABE, S.J. (2002) Biogeochemical processes that influence cave development within Bahamian carbonate platforms. *Proceedings of the Symposium Karst Frontiers: Florida and Related Environments: Special Publication 7*, Karst Waters Institute, pp 103–106.
- SCHWABE, S.J. and R.A. HERBERT (2004) Black holes of the Bahamas: what they are and why they are black. *Quaternary International* **121**, 3–11.
- SCHWABE, S.J., J.R. PARKES, and P.L. SMART (1997) Significance of bacterial activity in carbonate diagenesis. *Proceedings of the 8th Symposium on the Geology of the Bahamas and Other Carbonate Regions*

(1996), Bahamian Field Station, San Salvador, Bahamas, pp 174–175

STOESSELL, R.K., W.C. WARD, B.H. FORD, and J.D. SCHUFFERT (1989) Water chemistry and CaCO₃ dissolution in the saline part of an open-flow mixing zone, coastal Yucatan peninsula, Mexico. *Geological Society of America Bulletin* **101**, no. 2, 159–169.

WHITE, W. (1988) *Geomorphology and Hydrology of Karst Terrains*. Oxford University Press, New York, 464 pp.

INVESTIGATION OF BACTERIOPLANKTON COMMUNITIES IN AQUATIC KARST POOLS IN BÄRENSCHACHT CAVE OF BERNESE OBERLAND

TATIANA SHABAROVA, JAKOB PERNTHALER

Limnological Station, Institute of Plant Biology, University of Zurich, Seestrasse 187, CH-8802 Kilchberg, Switzerland

Karst subterranean aquifers are highly diverse in structure and very important in the formation of ground water, which is the main source of freshwater supply for a significant proportion of the world's population. Microorganisms can play an important role in karstification, carbon cycle and element mobility, but so far little is known about the bacteria of aquatic karst ecosystems. In this study, karst pools with differing hydrology in the Bärenschacht cave of the Bernese Oberland, Switzerland were investigated for a period of six months. Two crystalline pools were supplied by dripping water whereas one epiphreatic pool was renewed only by the rising groundwater table at intervals of several days to months. Chemical parameters such as conductivity, pH, ion concentration, as well as bacterial abundance and diversity were determined at several time points. The investigated pools showed remarkably different physicochemical parameters as well as bacterial properties. Although the dominant bacterial group in all three systems was β Proteobacteria, no population overlap inside this group was found between the crystalline pools and the epiphreatic system. Actinobacteria were present mainly in the systems with dripping water supply, whereas bacteria from the Flavobacteriaceae family were identified in both types of systems. Some microorganisms affiliated with Bacteroidetes could also be isolated and investigated in more detail. Generally, most of the identified microorganisms were not closely related to typical freshwater bacteria. Therefore, karst habitats might represent an environment for very specialized microorganisms.

1. Introduction

Ground water represents a major source of freshwater supply for a significant proportion of the world's population, and subterranean karst aquifers play a vital role in groundwater genesis and initial distribution. Presently, this resource is coming under increasing pressure due to the general recession of glaciers in the context of global warming (Ford and Williams, 2007).

The Bärenschacht cave of the Bernese Oberland (Switzerland) is characterized by an entrance part formed of shafts and steeply dipping galleries of mostly vadose origin which leads into a labyrinth consisting of galleries of mainly phreatic origin. The surface rocks above the cave consist of Globigerina marls and Flysch. Therefore, the water input into Bärenschacht originates almost entirely from the nearby Siebenhengste and Schratzenfluh cave systems that are located in the same catchment area (Häuselmann, 2002). Since Bärenschacht forms the hydrological link between these systems and the springs draining into Lake Thun (Häuselmann, 2002), it allows insight into the genesis and behaviour of an undisturbed deep karst system. Periodic flood events typically result in a rise of the water table in the labyrinthine part of the Bärenschacht cave system. As a consequence, there are numerous relatively small flood-formed pools in this section of the cave with water renewal

times ranging from days to years. These epiphreatic pools represent comparatively easily accessible model systems for a better understanding of the chemical and microbiological transformation that may occur in karst ground water at oxic condition.

Microorganisms can play an important role in karstification and they can influence carbon cycle and element mobility (Ford and Williams, 2007, Gabrovsek, et al., 2000). So far research about the subsurface microbiota in caves has frequently focused on chemoautotrophy, e.g., their utilization of the available sulphur sources (Macalady, et al., 2008, Barton and Luiszer, 2005). By contrast, little is known about the composition of the heteroorganotrophic microbial assemblages, in particular of those planktonic microbes that inhabit undisturbed and fully oxygenized karst water systems.

We studied the abundances and community composition of planktonic microbes in three oxygenated pools from the epiphreatic and vadose zone of Bärenschacht that differed in hydrology and water chemistry. In one of the systems we moreover compared two molecular biological approaches for cultivation-independent community analysis, 16S rRNA sequences analysis and determinative whole-cell fluorescence in situ hybridization (FISH).

2. Materials and Methods

Three pools in the labyrinth part of Bärenschacht cave were sampled at least monthly from October 2007 to March 2008. The epiphreatic pool NGIII is located in the Grand Nord gallery; it is approximately 20 m long and 0.5 m deep. The two pools JI and JII are similar in dimensions as NGIII, but differ in hydrology. They are situated in the Jessica gallery of the upper, non-flooded part of the labyrinth, and both JI and JII are exclusively fed by seepage water. Water samples were collected with sterile syringes from a depth of 5 cm. Subsamples for microscopic analysis were fixed with formaldehyde (2% final concentration) at the site. On several occasions (NGIII: December 29, 2007 and February 20, 2008; JI and JII February 25, 2008) unfixed pool water (1.5 to 2.5 l) was filtered onto white polycarbonate filters (type GTTP: 0.2 µm pore size; diameter, 47 mm, Millipore) in the cave to collect microbial biomass for later DNA extraction. The filters were directly placed into sterile tubes containing lysis buffer of the PowerSoil DNA Isolation Kit (MOBIO laboratories) for transport. All samples were delivered to the lab within 24 h after collection.

A data logger was placed on the bottom of the NGIII pool to monitor water temperature and water level. Conductivity and pH were measured after return to the laboratory with an InoLab benchtop meter (WTW) and a pH-Vision 6071 microcomputer (Jenco Electronics), respectively. Thirty ml of water sample was frozen for late determination of total organic carbon (TOC) on a TOC-5000 analyzer (Shimadzu). Nitrate concentrations in pool water were measured photometrically (cadmium reduction method) (Wood, et al., 1967) after filtration through membrane filters (type GTTP, Millipore) that had been pre-rinsed with 2 M HCl and deionised sterile water (Milli-Q, Millipore). The concentrations of sulphate, chloride and of cations were assessed by ion chromatography (Compact IC 761, Metrohm).

Bacterial abundances in pool NGIII were determined from formaldehyde-fixed samples. Portions of 2 to 5 ml were stained with 4',6-diamidino-2-phenylindole (DAPI, final concentration, 6.7 mg ml⁻¹) (Porter and Feig, 1980) and filtered onto black polycarbonate filters (pore size, 0.22 µm, diameter, 25 mm, Osmonics). At least 1000 bacteria per sample were counted by epifluorescence microscopy (AxioImager.M1, filter set 01, Carl Zeiss) at 1000X magnification. Five to 7 ml of formaldehyde-fixed samples from pool NGIII were filtered onto white polycarbonate filters (type GTTP, 0.2 µm pore size; diameter, 47 mm, Millipore), air-dried and stored at -20° C for later processing. Staining by FISH and catalyzed reporter

deposition (CARD) was performed as described previously (Sekar, et al., 2003). Horseradish peroxidase labelled oligonucleotide probes were applied that were targeted to all Bacteria (EUB I-III) (Daims, et al., 1999), β-Proteobacteria (BET42a), members of the Cytophaga-Flavobacteria lineage of Bacteroidetes (CF319a), α-Proteobacteria (ALF968), γ-Proteobacteria (GAM42a), and Actinobacteria (HGC69a) (Amann, et al., 1995). Tyramides custom labelled with the fluorescent dye Alexa488 (Invitrogen) were used for signal amplification. The hybridized filters were counterstained with DAPI (1 mg ml⁻¹) and the fractions of hybridized cells were determined in 500–1000 DAPI-stained cells by epifluorescence microscopy.

Biomass for DNA extraction was collected from JI and JII on Feb 25, 2008. NGIII biomass samples from two time points were pooled (December 29, 2007 and February 20, 2008). DNA was extracted with the PowerSoil DNA Isolation Kit (MOBIO laboratories). Primers GM3F and GM4R (Muyzer, et al., 1995) were used for the amplification of 16S rRNA genes. The purified PCR products (QIAquick PCR purification kit, QIAGEN) were cloned into E. coli (TOPO TA cloning kit, Invitrogen) and insert-bearing plasmids were prepared with the QIAprep Spin Miniprep Kit (QIAGEN). Sequencing of 16S rRNA genes with primers M13R, M13F (Messing, 1983) and GM1 F (Muyzer, et al., 1993) was carried out on an ABI 3130x Genetic Analyzer using the ABI BigDye chemistry (Applied Biosystems). Partial sequences were assembled (Vector NTI, Invitrogen) and checked for chimeric origin by the software Pintail (Ashelford, et al., 2005). Phylogenetic analyses were performed with the ARB software package (Ludwig, et al., 2004).

Cave water samples were plated on three types of media: YST (0.5g starch, 0.5 g yeast extract, 0.5 g peptone), PCA (Merck) and PCA/10. Two dilution factors were used: 10–1 ml and 10–2 ml. The plates were incubated first for 1 to 3 days at 18° C, and then for several weeks at 8° C. Isolated strains were weekly subcultured and identified by sequencing of their 16S rRNA genes.

3. Results and Discussion

Water temperature and pH were rather similar in all three pools and did not substantially vary during the study period (6.4 to 6.8° C and 7.6 to 7.8, respectively). Four flooding events were recorded, with maximal levels of the water table between 3 m (March 1–3, 2008) and 16 m (October 5–6, 2007) (Fig. 1). The effect of periodic flooding on the water chemistry of the epiphreatic NGIII pool was reflected in higher variability of TOC concentrations and conductivity,

as well as in changes in NO₃ concentrations in time periods separated by flooding events (e.g., 1.2 mg l⁻¹ in October/November 2007 vs. 2.2 mg l⁻¹ in December 2007/January 2008). TOC concentration in NGIII (3.2 ± 0.9 mg l⁻¹, mean ± 1 standard deviation) significantly exceeded those of the two crystalline pools (JI: 0.7 ± 0.3 mg l⁻¹; JII: 0.5 ± 0.4 mg l⁻¹), whereas the opposite was true for conductivity (NGIII: 190 ± 20 \square S cm⁻¹; JI: 345 ± 5 \square S cm⁻¹; JII: 360 ± 2.5 \square S cm⁻¹). Concentrations of NO₃ and Ca²⁺ were substantially higher in pool JI (5.46 ± 0.23 mg l⁻¹, and 72 ± 1 mg l⁻¹) than in the other two study systems (JII: 2.89 ± 0.17 mg l⁻¹ and 57 ± 1 mg l⁻¹; NGIII: 1.8 ± 0.7 mg l⁻¹ and 41 ± 4 mg l⁻¹). By contrast, JII featured substantially higher concentrations of SO₄ and Mg²⁺ than the other two pools.

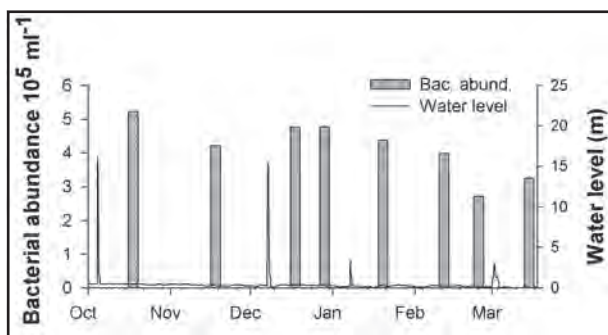

Figure 1: Changes in water level and of total bacterial abundance observed at the NGIII pool of Bärenschacht cave between October 2007 and March 2008.

Bacterial abundances in 8 samples from pool NGIII ranged between 2.7•10⁵ ml⁻¹ and 5.2•10⁵ ml⁻¹ (Fig. 1). Total cell numbers tended to decline with time if the period between successive flooding events exceeded one month (October to November 2007 and January to March 2008). This indicates that besides a growth arrest due to substrate limitation mortality by protistan predation or viral lysis might have affected the microbial communities (Perntaler, 2005). However, a microscopic inspection of several samples suggested that the abundances of free-living phagotrophic flagellates were very low (data not shown).

No quantitative microscopic analysis of bacteria on membrane filters was possible in samples from JI and JII, because (i) microbial cell numbers in the other two pools were extremely low (<10⁴ cells ml⁻¹) and (ii) the water from these systems contained high numbers of inorganic particles that impeded the evaluation of more concentrated samples. Therefore, no precise determination of bacterial abundances could be achieved. In order to quantify microbes from crystalline subsurface water pools it might be necessary to separate cells from particles by density gradient centrifugation (Fazi, et al., 2005), or to perform analyses by

flow cytometry (Hammes, et al., 2008). However, the low cell numbers in JI and JII might pose a problem even for these approaches.

A large fraction of bacterial 16S rRNA sequence types from NGIII and JII (41 and 40%, respectively) was related to β Proteobacteria, but <15% of all sequences from JI. A more detailed analysis of the phylogenetic affiliation of β Proteobacteria revealed striking differences between the three systems (Fig. 2): While Methylophilaceae represented the dominant group in NGIII, these bacteria were entirely absent in the other two habitats. Bacteria from this lineage have been found in high abundances in the sub-to anoxic layers of a mesotrophic lake, whereas they were rare in oxygenated waters (Salcher, et al., 2008). Most β Proteobacteria in the pools from the vadose zone were affiliated with either Comomonadaceae (JI) or Oxalobacteriaceae (JII). β -Proteobacteria are known to be a major component of bacterioplankton in many surface freshwater systems (Glöckner, et al., 1999). However, none of the sequence types from the studied pools was closely related to the typical lineages that are known from lakes or rivers, suggesting that subsurface karst pools may harbour a highly specialized planktonic microflora. This conclusion is further corroborated by the phylogenetic affiliation of other sequence types in our libraries. For example, several sequences from NGIII and JII fell into the TM7 and OP10 phyla, respectively, that are not known to occur in surface freshwater habitats (Zwart, et al., 2002). The crystalline pool with highest NO₃ concentration (JI) harboured several phylotypes affiliated with Nitrospira, a group of nitrite oxidizing bacteria known from soils (Roesch, et al., 2007) and nitrifying biofilms (Daims, et al., 2001). These bacteria were also detected in karst spring water samples during periods of low input of agriculturally influenced surface water (Pronk, et al., 2009). Interestingly, some phylotypes affiliated with Bacteroidetes were present both in the clone libraries and in the culture collection, which is in contrast to findings from surface waters (Alonso, et al., 2007).

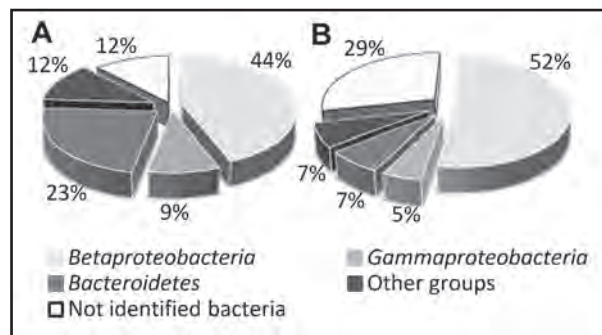

Figure 2: Phylogenetic affiliation of 16S rRNA gene sequences of β -Proteobacteria in the three studied pools NGIII, JI, and JII.

The detection rates of bacteria in NGIII by CARD-FISH varied from <40% of total cell counts in October/November 2007 to >60% in January/February 2008 (mean, $54 \pm 12\%$). This lies within the range of values reported for more productive surface freshwater systems (Posch, et al., 2009). Only between 49 % and 75 % of all hybridized Bacteria could be further identified by the set of group-specific probes, confirming the presence of other bacterial lineages as indicated by sequence analysis. β Proteobacteria represented the most abundant bacterial group that could be identified by FISH in all samples from NGIII ($48 \pm 7\%$ of Bacteria), followed by microbes affiliated with the Cytophaga-Flavobacteria lineage of Bacteroidetes (CFB, $8 \pm 2\%$ of Bacteria). By contrast the relative abundances of α Proteobacteria never exceeded 6% of hybridized cells, and Actinobacteria could only be detected in 2 out of 8 samples.

Figure 3 compares the fractions of sequence types affiliated with different bacterial taxa in the clone library from NGIII with the proportions of these groups detected by FISH on the same sampling time points. This allows an assessment of the bias that is potentially introduced by a preferential PCR amplification of particular sequence types (von Wintzingerode, et al., 1997). A clear overrepresentation of phylotypes affiliated with CFB was observed. By contrast, a somewhat higher fraction of β Proteobacteria was found in pool water by direct microscopic inspection than by cloning of 16S rRNA genes. Besides differential amplification by PCR it is conceivable that CFB might have featured higher numbers of rRNA operons than other bacteria. Bacteria affiliated with CFB formed the most prominent cultivable bacterial group from NGIII, and it has been

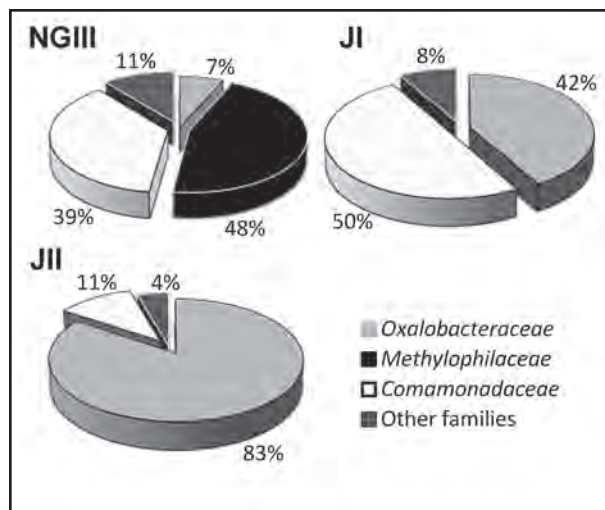

Figure 3. Community composition of Bacteria in pool NGIII according to phylogenetic analysis of 16S rRNA gene sequences (A) or microscopic assessment after CARD-FISH staining (B).

shown that isolates with higher rRNA operon number tend to form colonies on solid media more rapidly than others (Klappenbach, et al., 2000), and CFB bacteria formed the most prominent cultivable bacterial group from NGIII.

4. Conclusions

Three fully oxygenated subsurface karst pools with contrasting hydrogeology and chemistry were found to harbor diverse microbial assemblages. β -Proteobacteria constituted the most prominent bacterial lineage in all three systems, but each habitat featured a set of distinct genotypes affiliated with this group. Moreover, the fine-scale phylogenetic composition (at the level of genotypes) of the microbial assemblages in the studied pools clearly differed from surface water communities. Therefore, subsurface karst pools appear to feature a highly specialized planktonic microflora. However, a direct microscopic analysis of bacterial community composition in subsurface karst pools with long water residence times may be hampered by both high background of particulate matter and low cell numbers.

5. References:

ALONSO, C., F. WARNECKE, R. AMANN, and J. PERNTHALER (2007) High local and global diversity of Flavobacteria in marine plankton. *Environmental Microbiology* 9, 1253–1266.

AMANN, R.I., W. LUDWIG, and K.H. SCHLEIFER (1995) Phylogenetic identification and in situ detection of individual microbial cells without cultivation. *Microbiological Reviews* 59, 143–169.

ASHELFORD, K.E., N.A. CHUZHANOVA, J.C. FRY, A.J. JONES, and A.J. WEIGHTMAN (2005) At least 1 in 20 16S rRNA sequence records currently held in public repositories is estimated to contain substantial anomalies. *Applied and Environmental Microbiology* 71, 7724–7736.

BARTON, H.A. and F. LUISZER (2005) Microbial metabolic structure in a sulfidic cave hot spring: Potential mechanisms of biospeleogenesis. *Journal of Cave and Karst Studies* 67, 28–38.

DAIMS, H., A. BRUHL, R. AMANN, K.H. SCHLEIFER, and M. WAGNER (1999) The domain-specific probe EUB338 is insufficient for the detection of all Bacteria: Development and evaluation of a more comprehensive probe set. *Systematic and Applied Microbiology* 22, 434–444.

- DAIMS, H., J.L. NIELSEN, P.H. NIELSEN, K.H. SCHLEIFER, and M. WAGNER (2001) In situ characterization of Nitrospira-like nitrite oxidizing bacteria active in wastewater treatment plants. *Applied and Environmental Microbiology* 67, 5273–5284.
- FAZI, S., S. AMALFITANO, J. PERNTHALER, and A. PUDDU (2005) Bacterial communities associated with benthic organic matter in headwater stream microhabitats. *Environmental Microbiology* 7, 1633–1640.
- Ford, D.C. and P. Willams (2007) *Karst Hydrogeology and Geomorphology*. John Wiley & Sons, London, 576 p. 2nd ed.
- GABROVSEK, F., B. MENNE, and W. DREYBRODT (2000) A model of early evolution of karst conduits affected by subterranean CO₂ sources. *Environmental Geology* 39, 531–543.
- GLÖCKNER, F.O., B.M. FUCHS, and R. AMANN (1999) Bacterioplankton compositions of lakes and oceans: a first comparison based on fluorescence in situ hybridization. *Applied and Environmental Microbiology* 65, 3721–3726.
- HAMMES, F., M. BERNEY, Y.Y. WANG, M. VITAL, O. KOSTER, and T. EGLI (2008) Flow-cytometric total bacterial cell counts as a descriptive microbiological parameter for drinking water treatment processes. *Water Research* 42, 269–277.
- Häuselmann, P. (2002) *Cave genesis and its relationship to surface processes: Investigations in the Siebenhengste region (BE, Switzerland)*. PhD thesis, University of Fribourg, Fribourg.
- KLAPPENBACH, J.A., J.M. DUNBAR, and T.M. SCHMIDT (2000) rRNA operon copy number reflects ecological strategies of bacteria. *Applied and Environmental Microbiology* 66, 1328–1333.
- LUDWIG, W., O. STRUNK, R. WESTRAM, L. RICHTER, H. MEIER, YADHUKUMAR, A. BUCHNER, T. LAI, S. STEPPI, et al. (2004) ARB: a software environment for sequence data. *Nucleic Acids Research* 32, 1363–1371.
- MACALADY, J.L., S. DATTA GUPTA, I. SCHAPERDOTH, D.S. JONES, G.K. DRUSCHEL, and D. EASTMAN (2008) Niche differentiation among sulfur-oxidizing bacterial populations in cave waters. *Isme Journal* 2, 590–601.
- MESSING, J. (1983) New M13 Vectors for Cloning. *Methods in Enzymology* 101, 20–78.
- MUYZER, G., A. TESKE, C.O. WIRSEN, and H.W. JANNASCH (1995) Phylogenetic relationship of Thiomicrospira species and their identification in deep-sea hydrothermal vents by denaturing gradient gel electrophoresis of 16S rDNA fragments. *Archives of Microbiology* 164, 165–172.
- MUYZER, G., E.C. DE WAAL, and A.G. UITTERLINDEN (1993) Profiling of complex microbial populations by denaturing gradient gel electrophoresis analysis of polymerase chain reaction-amplified genes coding for 16S rRNA. *Applied and Environmental Microbiology* 59, 695–700.
- PERNTHALER, J. (2005) Predation on prokaryotes in the water column and its ecological implications. *Nature Reviews Microbiology* 3, 537–546.
- PORTER, K.G. and Y.S. FEIG (1980) The use of DAPI for identifying and counting aquatic microflora. *Limnology and Oceanography* 25, 943–948.
- POSCH, T., J. FRANZOI, M. PRADER, and M. M. SALCHER (2009) New image analysis tool to study biomass and morphotypes of three major bacterioplankton groups in an alpine lake. *Aquatic Microbial Ecology* 54, in press.
- PRONK, M., N. GOLDSCHIEDER, and J. ZOPFI (2009) Microbial communities in karst groundwater and their potential use for biomonitoring. *Hydrogeology Journal* 17, 37–48.
- ROESCH, L.F., R.R. FULTHORPE, A. RIVA, G. CASELLA, A.K.M. HADWIN, A.D. KENT, S.H. DAROUB, F.A.O. CAMARGO, W.G. FARMERIE, et al. (2007) Pyrosequencing enumerates and contrasts soil microbial diversity. *Isme Journal* 1, 283–290.

- SALCHER, M.M., J. PERNTHALER, M. ZEDER, R. PSENNER, and T. POSCH (2008) Spatio-temporal niche separation of planktonic Betaproteobacteria in an oligo-mesotrophic lake. *Environmental Microbiology* 10, 2074–2086.
- SEKAR, R., A. PERNTHALER, J. PERNTHALER, F. WARNECKE, T. POSCH, and R. AMANN (2003) An improved protocol for the quantification of freshwater actinobacteria by fluorescence in situ hybridization. *Applied and Environmental Microbiology* 69, 2928–2935.
- VON WINTZINGERODE, F., U.B. GÖBEL, and E. STACKEBRANDT (1997) Determination of microbial diversity in environmental samples: pitfalls of PCR-based rRNA analysis. *FEMS Microbiology Reviews* 21, 213–229.
- WOOD, E.D., F.A.J. ARMSTRONG, and F.A. RICHARDS (1967) Determination of Nitrate in Sea Water by Cadmium-Copper Reduction to Nitrite. *Journal of the Marine Biological Association of the United Kingdom* 47, 23.
- ZWART, G., B.C. CRUMP, M. AGTERVELD, F. HAGEN, and S.K. HAN (2002) Typical freshwater bacteria: an analysis of available 16S rRNA gene sequences from plankton of lakes and rivers. *Aquatic Microbial Ecology* 28, 141–155.

Symposium 6

INVENTORY OF CAVE AND KARST RESOURCES

Arranged by:
Jim Kennedy
Peter Matthews

KARST POTENTIAL INDEX: A TOOL FOR MAPPING KARST AT THE REGIONAL SCALE

JAMES C. CURRENS, RANDALL L. PAYLOR, MATTHEW M. CRAWFORD
Kentucky Geological Survey, University of Kentucky, Lexington, KY 40506 USA

Two GIS-based methods for ranking karst regions relative to other karst areas in the same climatic and geologic setting were developed. The Karst Potential Index (KPI) is based on lithology and the Karst Development Index (KDI) is based on karst geomorphic development.

We considered 10 measures for KDI, including conduit length per unit area, voids encountered by drilling, hydrograph coefficients, and epikarst thickness. Because data were incomplete for many of these measures, we chose sinkhole area, sinkhole count, and karst openings (sum of caves, springs, and swallow holes) for the KDI.

The KPI score is based on the lithologic characteristics of stratigraphic units mapped on digital 7½-minute geologic quadrangle maps. The KPI evaluates the favorability of the lithologic conditions for karst development. Each unique stratigraphic unit in Kentucky is ranked by percentage of section that is carbonate versus percentage that is non-carbonate, carbonate mineralogy (dolomite or calcite), carbonate grain size, and bedding thickness.

The KDI can only be used locally because of variable data availability. The KPI can be applied statewide, however, because all of Kentucky is mapped geologically at a scale of 1:24,000. Of the approximately 217,000 stratigraphic polygons that make up the digital geologic map of the state, 1,128 had all KDI criteria available. The polygons were grouped stratigraphically and ranked by both methods. A scoring weight was applied to the rankings based on our estimate of which criteria were the most critical. The data set was further simplified by calculating the average KDI for each stratigraphic unit with a common KPI. The KDI and KPI rankings were then tested statistically for similarity of means and correlation. The means were found to be different at $\alpha = 0.95$ confidence interval and the correlation coefficient (r^2) was 0.78 at $\alpha = 0.95$ confidence interval. The different means suggest the indices are sampling different populations and the strong correlation suggests that KPI can predict karst development. The KPI was used to create a Karst Potential Map of Kentucky.

1. Introduction

Over 50 percent of Kentucky is underlain at shallow depth by near-horizontal Paleozoic carbonates, and over 25 percent of the state is mature karst with obvious surface features and integrated conduit and cave systems. A karst classification method is needed for Kentucky because qualitative descriptors are inadequate to identify the more vulnerable and hazardous karst. The method described in this paper is a regional approach and not intended as a replacement for site-specific investigations; a statewide karst classification system would be useful for planning large projects, however.

2. Previous Research

Karst development has been classified by many authors (Quinlan, 1967; Jennings, 1971; Sweeting, 1973). Recent quantitative work by Weary and Orndorff (2001) relates

karst development to structure (dip and jointing) and hydraulic gradient. They used GIS files of doline polygons, spring points, and cave entrances to calculate karst density. The Karst Task Force of the Resources Inventory Committee of British Columbia adopted work by Baichtal et al. (1995) in their Karst Inventory Standards (Karst Task Force, 2001). They rated polygons of carbonate outcrop, the terminology reflecting the Geographic Information System (GIS) approach to data management. Glennon and Groves (2002) used a GIS approach to geomorphic analysis of the Mammoth Cave area, Kentucky. They used five previously published techniques of calculating stream density for cave streams and at the surface in a nearby non-karst watershed. Davis (2002) discussed a variation of DRASTIC, called KARSTIC. The method utilizes factor weights and ratings, which are multiplied, then summed. The EPIK method was developed for conditions in Switzerland

and considers epikarst development, protective cover, infiltration conditions, and karst network development (Doerflinger and Zwahlen, 2000). Qualitative classifications are converted to a numerical ranking, which are summed to yield a Protection Index, which are linked to set-back distances and permitted uses.

Klimchouk and Ford (2000a) described the progression of development of karstification or karstic porosity as being independent of depth of burial. They described the evolution and functioning of karst systems for various hydrogeologic settings: syngenetic, intrastratal, exposed, mantled karst, buried karst, and paleokarst. Klimchouk and Ford (2000b) also discussed the lithologic characteristics affecting bedrock solubility and cave genesis. They considered rock purity, the presence of interbedded clastic rocks, and the type of pre-karst porosity. Most notable is their statement that “limestone with more than 20-30% clay (argillaceous limestone) forms little karst” and that “most limestone and dolostone caves are associated with bulk purities of greater than 90 percent.” They also mentioned the greater rate of solubility of limestone versus dolostone, but gave no quantitative measures. Beds greater than medium thickness (10-30 cm) are more prone to cave development because of the greater concentration of flow to comparatively few bedding planes.

The Waltham and Fookes (2003) method has similarities to the classification system proposed here. They described a five-class karst system that is based on the concept of karst maturity. The Karst Class is one criterion in a conceptual summation that includes sinkhole density, cave size, and “rockhead” relief. They defined sinkhole density as the count of features per unit area. Cave size is the maximum width possible in the project area. The rockhead relief is the average distance from the top of the pinnacles to the bottom of the cutters (grikes).

3. Linear Algorithm

The indices proposed here are based on linear algorithms. The first use of a linear algorithm for ranking or indexing natural systems was to evaluate the health of aquatic biological communities, specifically fish (Karr, 1964). Karr modified his equation from the communication theory work of Shannon and Weaver (1964). Shannon and Weaver used the linear equation to quantify various components of a discrete, noiseless signal, L_i with probability p_i , such that the composite signal L equals the sum of the components $L = L_i p_i + L_{i+1} p_{i+1} + \dots + L_{i+n} p_{i+n}$. An index of biological integrity, or an index of any other natural system, can be conceptualized as analogous to a signal with two or more alternative

components (Karr et al., 1986). In Karr’s application, the weighting adjusted the criteria values for the effect of up- or downstream position of the stream reach and the seasons, and was mostly based on the author’s field experience. Karr’s Index of Biotic Integrity (IBI) is now extensively used for assessing biological integrity of streams and other biological applications (U.S. EPA, 2004).

4. The Digital Geologic Map of Kentucky

The utilization of a karst index is dependent on the existence of a suitable geologic map. Large-scale mapping began in Kentucky in 1960 and was completed by 1978 (Cressman and Noger, 1981). The state is entirely mapped at 1:24,000 scale, resulting in the publication of 706 geologic quadrangle maps. The geologic maps have been digitized and combined into thirty-two 30 x 60 minute quadrangle maps (Anderson et al., 1999). The outcrop areas of all stratigraphic units in Kentucky are represented digitally. Each polygon has attributes assigned to it that include a formation code and name. Stratigraphic data related to karst potential were mined from the online Kentucky Geological Survey 7.5-minute geologic map descriptions, and entered into spreadsheets.

5. Karst Indices for Kentucky

The two numeric indices described here are similar in structure to the IBI (Karr, 1964). We hypothesize that the Karst Potential Index (KPI), based on lithology, is a predictor of karst geomorphologic development. The second ranking method, the Karst Development Index (KDI), evaluates karst geomorphologic development utilizing the presence and aerial density of karst features. Both classification schemes produce an ordinal ranking.

We assumed that variation in climate was negligible across Kentucky. Other assumptions were that the KDI would be a measure independent of the KPI, and that sufficient and meaningful data would be available to calculate a KDI for a sufficiently large set of polygons to have a statistically valid test. We also assumed that a correlation between the KPI and the KDI would be causally related.

6. Karst Development Index

The KDI is intended to estimate relative karstic development, normalized for the combined area of the polygons representing a single stratigraphic unit. The KDI considers the density of springs, swallow holes, and cave entrances in a stratigraphic unit, the percentage of the formation area occupied by sinkholes, and the number of sinkholes per area. The count of caves was combined with springs and swallow holes because many cave entrances have

the same genesis. Some other measures evaluated were cave length as a measure of karst aquifer integration and depth to bedrock from water-well drilling records and soil maps, used as a surrogate for epikarst development. The three criteria utilized for the KDI were selected because of the uniformity of the data sets. The other measures were not used in the final analysis because of a lack of data quality and completeness. The feature counts and areas were divided by the formation area and assigned a rank of 1 to 4 based on quartiles. The resulting ranks were calculated as follows:

$$KDI = 1(Sc) + 2(Ko) + 3(Sd), \text{ ranging from 6 to 24}$$

where **Sc** = sinkhole coverage/formation area: weight = 1 ($1 \leq Sc \leq 4$); **Ko** = karst openings (springs, swallow holes, and caves)/formation area: ($1 < Ko \leq 8$); and **Sd** = sinkhole density (count of closed basins)/formation area: ($1 \leq Sd \leq 12$).

7. Karst Potential Index

The KPI score is based on the lithologic characteristics of stratigraphic units as mapped on the digitized versions of 7½-minute, 1:24,000-scale geologic quadrangle maps. Jennings (1971), White (1988), and Ford and Williams (1989) described the following relationships in the solubility of carbonate bedrock. Limestone is more soluble than dolostone. Pure limestone is more soluble than argillaceous or cherty limestone. Calcilitite (fine-grained) limestone is more soluble than calcirudite (coarsely crystalline or fossiliferous) limestone. Thick-bedded carbonates are associated with larger cave systems. Limestone with thick beds has continuous bedding planes of larger areal extent, which promotes initial groundwater circulation and allows long flow paths. The wider spacing of bedding planes also tends to concentrate groundwater flow along fewer routes (Klimchouk and Ford, 2000b). Secondarily, the roofs of any conduits formed in thick beds are stronger than those in thin beds and do not easily collapse to block flow temporarily (White, 1988). The carbonate rock with the lowest karst potential would be a thin-bedded, argillaceous, sparry dolostone. Pure micrite limestone in massive beds would have the highest karst potential. Both will form karst features, but the coarser-grained, argillaceous dolostone will take much longer to form karst (Ford and Williams, 1989; White 1988).

The absence of insoluble material (clay, silt- and sand-size quartz) from an otherwise mostly calcitic rock is widely recognized as the most important single criterion promoting karstification (Klimchouk and Ford, 2000b). If the rock has a significant fraction of insoluble minerals,

it will not form karst because the incipient karst conduits, or initially widened fractures, are blocked with insoluble residue, inhibiting groundwater flow and further dissolution. Klimchouk and Ford (2000b) considered 50 percent clayey insoluble residue as the practical limit for karst development. Arenaceous carbonates, with up to 50 percent quartz sand, may still form significant caves (White, 1988). We designated all rocks with greater than 50 percent insolubles as non-karstic. As in the case of insoluble residue, calcite and dolomite analyses are often available. Calcite is more soluble relative to dolomite under the same temperature, pressure, and pH conditions. Grain size affects the surface area exposed to water, and a larger surface area provides a larger diffusion area for the dissolution process. Finer-grained carbonates have a larger ratio of grain surface area to mass than coarse-grained rocks because for each increase in radius, the area of a sphere increases proportionally slower than the volume it contains. Therefore, finer-grained rocks dissolve more quickly and grain size is inversely related to solubility (Klimchouk and Ford, 2000b). The Karst Potential Index scores criteria for bedding thickness, percentage of the stratigraphic unit that is insoluble, carbonate grain size, and the percentage of the carbonate bedrock that is calcite (Table 1).

The KPI is evaluated by determining in which division the data are included and noting the rank. The rank for each criterion is then multiplied by the significance weight and the weighted scores are summed to produce the overall KPI score. A spreadsheet was used to calculate the KPI linear equation below:

$$KPI = 4(Ir) + 3(Bt) + 2(Gs) + 1(Cp), \text{ ranging from 6 to 40}$$

where **Ir** = percent of insoluble rock in stratigraphic section ($4 \leq Ir \leq 16$); **Bt** = bedding thickness ($3 \leq Bt \leq 12$); **Gs** = carbonate grain size ($2 \leq Gs \leq 8$); and **Cp** = calcite percentage of the carbonate rock ($1 \leq Cp \leq 4$). Unlike the KDI, the KPI can be calculated for the entire state because of the complete geologic mapping coverage.

8. Polygon Sample Selection

All of the approximately 217,000 stratigraphic polygons that make up the digital geologic map of the state were tested for the presence of features from the three KDI data sets. The complete set of features occurred in 1,128 polygons. The number of formation polygons was further reduced by eliminating those with greater than 50 percent non-carbonate. Many of the eliminated polygons represented insoluble rocks (caprock) overlying carbonate rocks and

Percentage of insoluble rocks in stratigraphic Unit $W = 4 \Rightarrow$		4	3	2	1	Bed thickness $W = 3 \Downarrow$	
		< 8%	8 to 15%	15 to 25%	25 to 50%		
4	100% to 95% calcium carbonate (Limestone)	very high potential				very thick >100cm	4
	95% to 75% calcium carbonate (dolomitic limestone)		high potential			thick 30-100cm	3
2	75% to 50% calcium carbonate (calcitic dolostone)			moderate potential		medium 10-30cm	2
1	<50% calcium carbonate (dolostone)				low potential	very thin <10cm	1
Percentage of calcite in the carbonate rock $W = 2$		calcilitite (micrite)	calcisiltite	calcarenite	calcirudites (bioclastic)	Carbonate grain size $\Leftarrow W = 1$	
		4	3	2	1		

Table 1: Scoring matrix for evaluating the Karst Potential Index (KPI) for GIS digital polygons representing stratigraphic units in Kentucky.

alluvium in valleys (mantled karst). The remaining polygons were merged according to stratigraphic unit, resulting in 57 unique stratigraphic units to compare to the KPI.

9. Results

The KPI and KDI were evaluated using statistical procedures in STATGRAPHICS software. The individually ranked components of the KDI and KPI were also tested for sample distribution. All four KPI criteria and all three KDI criteria were found to be not normally distributed and had large variances. The individual KDI criteria data sets are log-normally distributed, typical of many natural phenomena (Davis, 1986), whereas the two quantitative KPI criteria (percent insolubles and percent calcite) were neither log-normally nor normally distributed.

Two sample sets were evaluated for equivalence of means and correlation (Figs. 1 and 2). The 57 paired values of the polygons that remained after the stratigraphic polygons were merged, and a set of 33 paired values representing the average KDI for each unique KPI value were derived from the 57-member data set (Figs. 1 and 2). By averaging the KDI values for the stratigraphic units with a common KPI, the large variance resulting from spotty availability of the KDI data was further smoothed. The 33-pair data set was

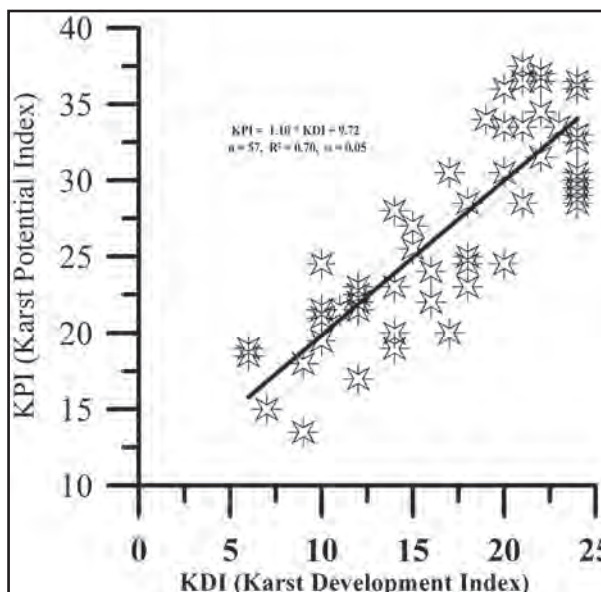

Figure 1: Correlation of the independently determined karst indices. The multiple KPI scores that occur for the same KDI score are caused by stratigraphic units with similar lithologies with a narrow range of karst development.

not statistically different from a normal distribution for the KPI total using the Kolmogorov-Smirnov test. The KPI and KDI scores were then compared to test the KPI predictive

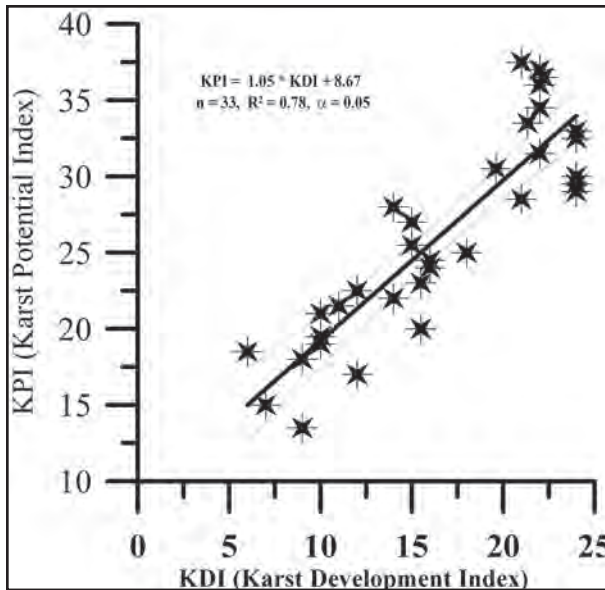

Figure 2: Correlation of the KDI value from composited polygons representing a single stratigraphic unit. A given KPI score may occur for a number of stratigraphic units with a narrow range of KDI score.

capability. The correlation coefficient (r^2) was 0.70 for the 57-pair set when compared to KPI, and was 0.78 for the 33 paired scores. The equation of the regression is $KPI = (1.05 KDI + 8.66)$ $r^2 = 0.78$ at $\alpha = 0.95$ confidence interval. The means of the two indices were found to be statistically different at the $\alpha = 0.95$ confidence interval.

10. Karst Potential Map of Kentucky

To create the new Karst Potential Map of Kentucky, each of the stratigraphic units represented on the digital geologic

map were assigned a KPI score based on the lithologic data in the attribute table of the digital map. Because of the large number of possible scores over the full range of KPI (40), the scores were grouped into classes to make the map more readable at 1:250,000 scale (Fig. 3). The larger-scale paper map contains 10 classes, resulting in a rationally constructed and consistently evaluated map that is also aesthetically pleasing.

11. Conclusions

The findings suggest that the KPI and KDI are independent measures (different means) and the KPI is a reliable predictor of karst development as estimated by the KDI (positive correlation among stratigraphic units). The results further suggest that the KPI has potential as a predictive tool for karst development in the climatic and geologic setting of Kentucky and potentially other areas of the Interior Low Plateaus. Because it is an objectively determined measure, it can be used as a first screening tool for selecting sites for critical or risky facilities.

References

- ANDERSON, W.H., T.N. SPARKS, J.A. PATTON, X.Y. YANG, and R.E. SERGEANT (1999), Integration of relational geologic database and a spatial map database in Kentucky, in *Digital Mapping Techniques 1999, Workshop Proceedings*. U.S. Geological Survey Open-File Report 99-386, 123–126.
- BAICHTAL, J.F., D.N. SWANSTON, and A.F. ARCHIE (1995), An ecologically-based approach to karst and

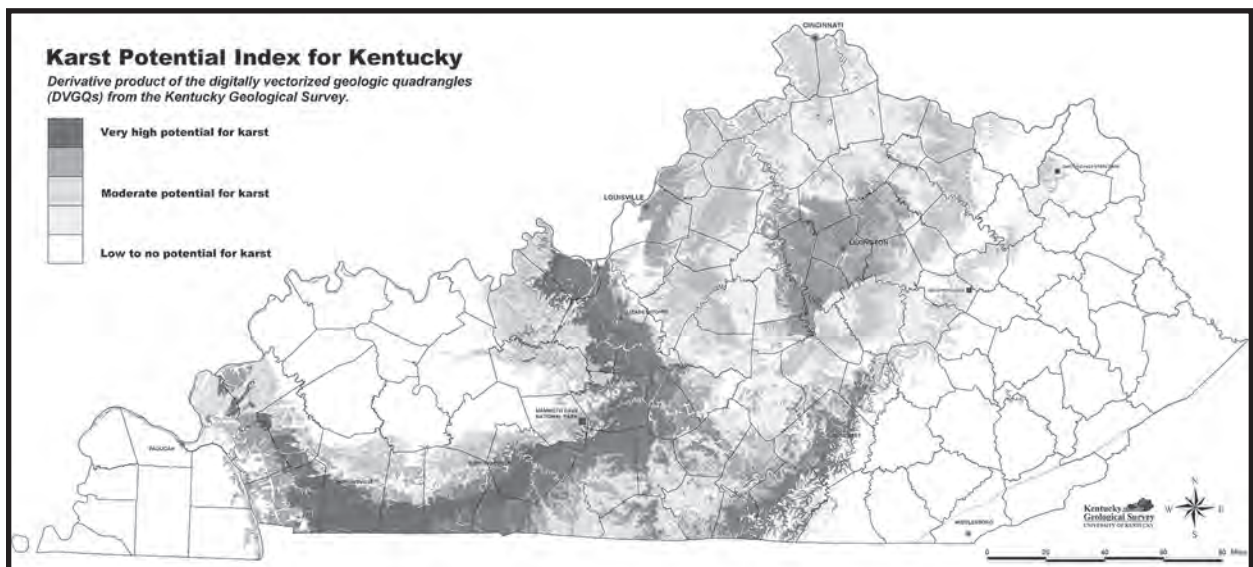

Figure 3: Small-scale map of Kentucky showing a simplified Karst Potential Index. In this example the maximum of 30 incremental shades have been grouped together into five categories.

- cave resource management. Proceedings, National Cave Management Symposium, Spring Mill State Park, Mitchell, Ind., 18 pp.
- CRESSMAN, E.R. and M.C. NOGER (1981), Geologic mapping of Kentucky; history and evaluation of the Kentucky Geological Survey—U.S. Geological Survey Mapping Program, 1960-1978. U.S. Geological Survey, Circular 801, 22 pp.
- DAVIS, A.D. (2002), KARSTIC: a sensitivity method for carbonate aquifers in karst terrain. Environmental Geology, **42**, 65–72.
- DAVIS, J.C. (1986), *Statistics and data analysis in geology*. John Wiley and Sons, New York, 2nd ed., 646 p.
- DOERFLINGER, N. and ZWAHLEN, F. (2000), Groundwater vulnerability mapping in karstic regions (EPIK). Swiss Agency for the Environment, Forests, and Landscapes, Berne, VU-2504-E, 56 pp.
- FORD, D.C. and P.W. WILLIAMS (1989), Karst geomorphology and hydrology: Unwin Hyman Ltd., London, 601 pp.
- GLENNON, A. and C. GROVES (2002), An examination of perennial stream drainage patterns within the Mammoth Cave watershed, Kentucky. Journal of Cave and Karst Studies, **64-1**, 82–91.
- JENNINGS, J.N. (1971), *Karst*. M.I.T. Press, Cambridge, Mass, 252 pp.
- KARST TASK FORCE, RESOURCES INVENTORY COMMITTEE (2001), Karst inventory standards and vulnerability assessment procedures for British Columbia: Government Publications Centre, National Library of Canada Cataloguing in Publication Data, www.for.gov.bc.ca/ric, 112 pp.
- KARR, J.R. (1964), Assessment of biotic integrity using fish communities. Fisheries, **6-6**, 21–27.
- KARR, J.R., K.D. FAUSCH, P.L. ANGERMEIER, P.R. YANT, and I.J. SCHLOSSER (1986), Assessing biological integrity in running waters: a method and its rationale. Illinois Natural History Survey, Special Publication 5, 28 pp.
- KLIMCHOUK, A.B. and D.C. FORD (2000a), Types of karst and evolution of hydrogeologic setting, in Speleogenesis, Evolution of Karst Aquifers, A.B. Klimchouk, D.C. Ford, A.N. Palmer, W. Dreybrodt, (Eds.), National Speleological Society, Huntsville, Alabama, pp 45–53.
- KLIMCHOUK, A.B. and D.C. FORD (2000b), Lithologic and structural controls of dissolutional cave Development, in Speleogenesis, Evolution of Karst Aquifers, A.B. Klimchouk, D.C. Ford, A.N. Palmer, W. Dreybrodt, (Eds.), National Speleological Society, Huntsville, Alabama, pp 45–53.
- QUINLAN, J.F. (1967), Classification of karst types: A review and synthesis emphasizing the North American literature. National Speleological Society Bulletin, **29-3**, pp 107–109.
- SHANNON, C.E. and W. WEAVER (1964), *The mathematical theory of communication*. University of Illinois Press, Urbana, 128 pp.
- SWEETING, M.M. (1973), *Karst landforms*. Columbia University Press, New York, 362 pp.
- U.S. Environmental Protection Agency (2004) accessed 2009, <http://www.epa.gov/bioindicators/html/ibi-hist.html>
- WEARY, D.J. and R.C. ORNDORFF (2001), Physical controls on karst features in the Ozark Plateaus of Missouri, U.S.A., as determined by multivariate analyses in a Geographic Information System (GIS). Acta Carsologica, **30-2**, 181–194.
- White, W.B. (1988), *Geomorphology and hydrology of karst terrains*. Oxford University Press, New York, 464 p.
- WALTHAM, A.C. and P.G. FOOKES (2003), Engineering classification of karst ground conditions. Quarterly Journal of Engineering Geology and Hydrogeology, **36**, 101–118.

TROGGLE: A NOVEL SYSTEM FOR CAVE EXPLORATION INFORMATION MANAGEMENT

AARON CURTIS

Cambridge University Caving Club

aaron.curtis@cantab.net

Over the last year, current and former members of the Cambridge University Caving Club (CUCC)'s expeditions to Austria have worked to develop an improved system of managing and accessing expedition data, dubbed "Troggle." Troggle consists of a robust relational database with a user-friendly, wiki-like Web interface that can be run either over the Internet or on a single local computer. To date, over a thousand pages of trip reports, cave descriptions, lists of leads ("QM lists"), centerline data, and expedition personnel details have been integrated into the database from 30 years of expeditions. We envision the expansion of Troggle to include data types such as drawn-up surveys, surface prospecting GPS tracks, georeferenced photos, meteorological and other scientific data, and expedition publications. A key principle is that wherever data types are related in reality, they are related in Troggle. This enables Troggle to answer queries like "show me all photos taken in cave X between 2000 and 2005, not including those taken by John Doe" or "list all of the going leads in caves where airflow greater than 5 m/s was recorded at 1500 on 21NOV2008." Thus, Troggle is a fully searchable metadata structure.

As Troggle becomes integrated into the expedition routine, it will automate processes before, after, and during the expedition. Expedition member signup and construction of a resulting online calendar avoids repetitive manual coding. Access to sensitive information (e.g. medical conditions or contact information) is protected by user-specific passwords. During the expedition, unified computerized forms are completed after each trip which record all necessary information to update QM lists, logbooks, survey lists, and prompt for photo and/or GPS track uploads. In the past, CUCC had a complicated system of tables and scripts to maintain the workflow necessary to coordinate survey production for large caves. With the increased automation available in Troggle, it will be possible to pull up a list of all hand drawn surveys that require scanning, all scans that need digital tracing, and all traced scans that must be joined to the master survey.

Behind the scenes, the system uses the Django Web Framework, which allows database tables (Django "models") and Web interfaces (Django "views" and "forms") to be created and managed with minimal Python code, and provides an object-oriented application programming interface (API) for database access. Currently, the underlying database is stored in MySQL, although the flexibility of Django makes the switch to other database backends trivial.

While Troggle was initially conceived for use on CUCC expeditions, it has broader applicability. All code is free, cross-platform, and open source. Other expeditions are encouraged to use it, and it may be adapted for use outside of an expedition context.

1. Why Cavers Need Effective Data Management

Cave exploration is more data-intensive than any other sport. The only way to "win" at this sport is to bring back information: abundant and interesting survey, photos or scientific data. Aside from the data collection requirements of the game itself, setting up a game (an expedition) of cave exploration often involves collection of personal information ranging from dates available to medical

information to the desire to purchase an expedition t-shirt.

If an expedition will only happen once, low-tech methods are usually adequate to record information. Any events that need to be recorded can go in a logbook. Survey notes must be turned into finished cave sketches, without undue concern for the future expansion of those sketches.

However, many caving expeditions are recurring, and

managing their data is a more challenging task. For example, let us discuss annual expeditions. Every year, for each cave explored, a list of unfinished leads (which will be called “Question Marks” or “QMs” here) must be maintained to record what has and has not been investigated. Each QM must have a unique ID, and information stored about it must be easily accessible to future explorers of the same area. Similarly, on the surface, a “prospecting map” showing which entrances have been investigated needs to be produced and updated at least after every expedition, if not more frequently.

These are only the minimum requirements for systematic cave exploration on an annual expedition. There is no limit to the set of data that would be “nice” to have collected and organized centrally. An expedition might collect descriptions of every cave and every passage within every cave. Digital photos of cave entrances could be useful for re-finding those entrances. Scans of notes and sketches provide good backup references in case a question arises about a finished survey product, and recording who did which survey work when can greatly assist the workflow, for example enabling the production of a list of unfinished work for each expedition member. The expedition might keep an inventory of their equipment or a catalog of their library. Entering the realm of the frivolous, an expedition might store mugshots and biographies of its members, or even useful recipes for locally available food. The more of this information the expedition wishes to keep, the more valuable an effective and user-friendly system of data management.

2. What’s Different about Troggle?

Troggle is part of a long series of paper-based and computerized utilities the Cambridge University Caving Club (CUCC) has developed to make our expeditions run more smoothly. Over the last 32 years, expedition members have produced programs for survey processing and data management. Early innovation included the use of programmable calculators to replace slide rules, FORTRAN and then BASIC programs, HTML cave descriptions. Today, CUCC uses the surveying programs Surverx and Tunnel, written by expedition members, to produce survey sketches, and a system of spreadsheets and scripts are used to generate our Web site from raw data.

However, Troggle is a huge leap forward. It replaces the mess of scripts and spreadsheets, with a powerful, user-friendly system. For the first time, we have a unified system which can manage any type of expedition data, and which understands the relationships between the data. For the

first time, CUCC has a system which can be recommend to other expeditions.

Using a relational database, Troggle represents familiar expedition concepts such as the cave, the person, and the logbook entry in tables. All of the links which exist between these concepts in real life, such as the fact that logbook entries are always written by people and can sometimes refer to caves, exist in the database as foreign keys between models.

3. Troggle: From the User’s Perspective

All of the data in the Troggle database is created, viewed, and edited through a Web browser. However, by no means does Troggle require the Internet to function. A Troggle server (either the Django development server or any Web server with mod_python set up to work with Django) is a lightweight program which can be run on any computer with Linux, Mac, Windows, or many other operating systems. If run on an expedition computer connected to a wired or wireless LAN, it could be simultaneously used on the expedition computer as well as any number of laptops expedition members may have brought with them. Troggle can also be run on a dedicated server used as an expedition Web page handling high volumes of traffic. Web pages based on similar technology can served as many as 500,000 pages an hour (for more about scalability of the Django platform which Troggle uses, see <http://www.davidcramer.net/other/43/rapid-development-serving-500000-pageshour.html>). For this discussion, let us assume that Troggle is hosted by a server at troggle.cavingexpedition.com.

Troggle’s URLs are set up so that things are easy to get at. There is no need to send the browser to a certain file as you would with a conventional Web page; in fact the file you are looking for is not written until you ask for it. If I wanted to access a person page for Joe Smith, I could type in any of the following, and they would bring me to his profile page:

- troggle.cavingexpedition.com/person/joe_smith
- troggle.cavingexpedition.com/people/joe_smith/
- troggle.cavingexpedition.com/person/JoE_sMlth
- troggle.cavingexpedition.com/people/Joe Smith
- troggle.cavingexpedition.com/person/JoeANYtHiNg123!@#HERESmith

If I typed:

troggle.cavingexpedition.com/person/joe

then Troggle would present me with a list of all of the

people named joe. For a list of all people, I would go to

troggle.cavingexpedition.com/person/ or troggle.cavingexpedition.com/people/.

Similar flexibility exists for looking up expeditions, caves, logbook entries, and other objects.

A new expedition member's first encounter with Troggle might be when uses it to sign up for the expedition, by going to troggle.cavingexpedition.com/register/. Troggle uses the familiar 'activation email' strategy of verifying user email addresses where a user is sent an activation key link which they click on or paste into their browser. Once registered, the user is asked to fill out information which the expedition needs about them: what dates they will be available, next of kin, etc. The user is also asked if they have attended previous expeditions, in which case they will be asked for their name, and the existing information about them will be attached to their user account.

Instantly, this becomes useful information for the expedition leader, who is planning the expedition and wants to know how many people will be present for each day of the

expedition. When the user submits their available dates, the calendar for that expedition (Fig. 1) appears updated. In actual fact, nothing is updated except for a cell in the database's Person table, because the calendar does not exist in a file; it is generated dynamically each time it is loaded (unless none of the information accessed changes; Django will improve performance by serving a cached version of the page).

On the expedition itself, Troggle is used to record each trip. In CUCC's case, an expedition member will typically spend four or five days at top camp caving before she hikes back down to base camp. When she arrives in base camp, she enters information about the trips she was on: who was on each trip, where the trip went, dates, which going leads (QMs) are no longer going, which new going leads need to be added to the database, and whether the trip brought back any new survey. The information she adds immediately becomes accessible from many different parts of the site. If she writes a trip description, it shows up in the logbook for that year (Fig. 2). On the page for the cave she visited, her trip will appear in the list of trips to that cave, and her QMs appear in the list of dead and going leads, respectively.

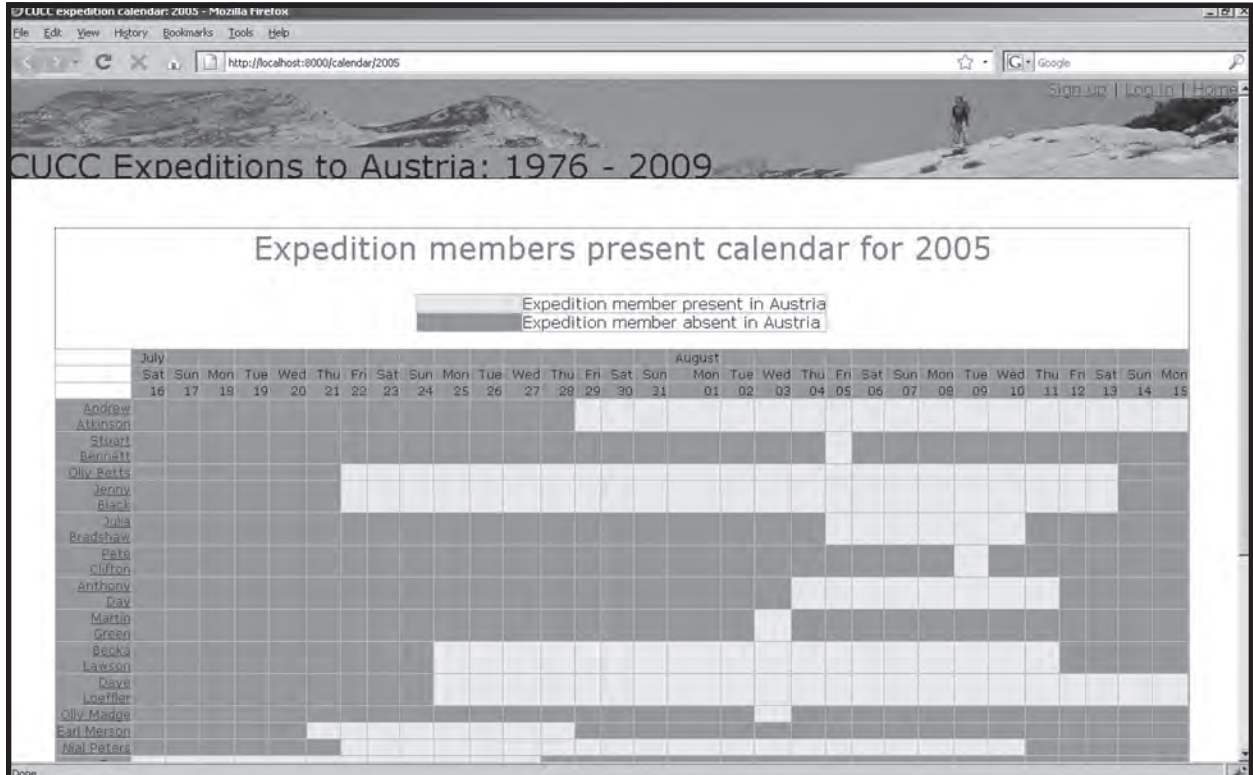

Figure 1: The automatically updated expedition calendar. For past expeditions such as 2005 (shown) dates present for people were inferred from the existence of logbook entries, and are therefore very approximate. From 2009 on, dates will be those specified by the expedition members themselves when signing up for the expedition. Clicking on a person's name links to information about that person.



Figure 2: The expedition index page, with links to pages for related logbook entries, caves, and people.

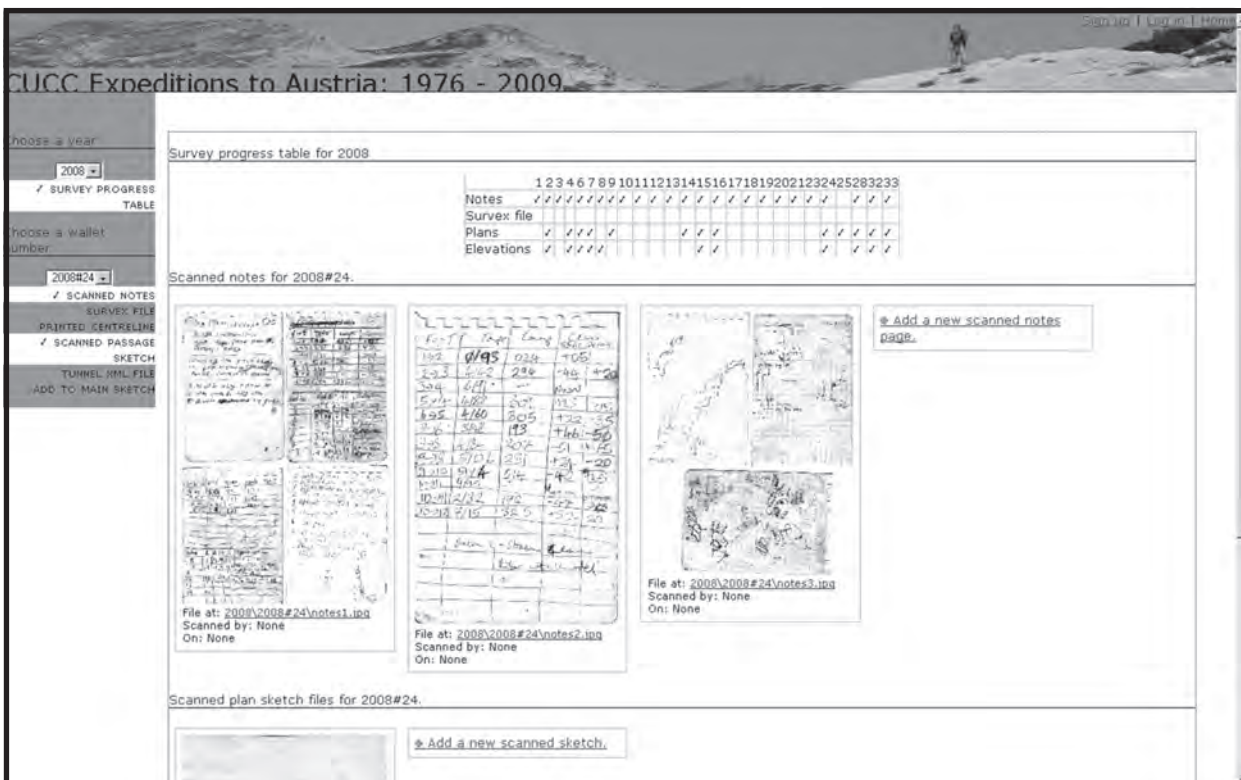

Figure 3: Troggles “Virtual Survey Binder.” Check marks show items which the database knows are present in the file structure. Different items can be toggled on and off using the left hand navigation menu.

Now the survey work begins. If she stated that her trip produced survey, Troggle will send her to its Virtual Survey Binder, troggle.cavingexpedition.com/surveys/ (Fig. 3). This page guides her through the expedition workflow which will eventually end in integrating her new information into the final survey. Our caver can take a break for a beer or five at any point during this process, and Troggle will keep track of what needs to be done. For each year, such as troggle.cavingexpedition.com/surveys/, it displays a table with each section of survey and what workflow stages have been completed.

4. Troggle: Under the Hood

What makes all of this magic possible? Troggle is a “Django project.” This means it is a set of data models, views, and templates (also parsers to convert from the legacy data structure) to be used with Django, a Web framework for the programming language Python. Django represents all of the data models as tables in a relational database and automatically creates and sends SQL commands to control that database. (Currently, Troggle is being developed with MySQL, but switching to another database backend is as simple as changing a variable in a configuration file.)

When a user requests a URL, and it is handled by Django (if using Apache, `mod_python` passes the request to Django, other Web servers have analogous modules), Django checks the incoming URL against a list of python regular expressions. Troggle’s flexibility with URLs comes from the fact that we have written very loosely matching regular expressions. Once Django finds a regular expression which returns a match for the URL, it runs a python function (a “view”) which takes the URL, draws relevant information from the database, and uses it to fill in a template written in the Django template language, producing a HTML page for display user.

Database access is facilitated by the powerful Django Object Relational Mapper (ORM), accessed through a Python application programming interface (API). Each data model, such as the “Cave,” “Person,” or “Logbook Entry” model, is accessible as a Python object with useful methods that allow powerful searching, editing, and saving of the database from python. Here are some lookup scenarios, ranging from the simple to complex, with the necessary python code.

- Get a list of all people who have been on the expedition and store it as result
`result=People.objects.all()`
- Get a list of all people who were on the 2004 expedition and store it as result

```
result=Expedition.  
get(year=2004).people_set.  
all()
```

- Get the text of the logbook entry with “intrepid voyage” in the title and store it as result
`result=LogbookEntry.
objects.get(title__
contains=“intrepid voyage”.
text`
- Get a list of all photos taken in a cave whose official name begins with “Stein” in the year 2000, and store it as result
`result=Photo.objects.
filter(cave__official_name_
_startswith=“Stein”).
filter(date__year=2000)`

Of course, the API is not accessible through a Web browser, and Troggle users should never need to query the database directly using the commands in the example above. However, the API is what drives the views and templates and is therefore used whenever a page is loaded.

5. Tailoring Troggle to Your Needs

Three aspects of Troggle’s design make it highly customizable. First, all paths and URLs are relative to variables in a settings file. Second, because Troggle takes advantage of Django’s powerful template inheritance, one HTML file and one CSS file control the appearance and style of the entire Web site. Third, Troggle’s modular structure allows the addition of alternate or new components.

The locations of files and other aspects of in system setup are set as variables for using the file “`localsettings.py`”. This file also contains all of the information necessary to access the database Troggle will use. Changing the variable `DATABASE_ENGINE` allows the use of different database systems; Postgresql, Mysql, Sqlite3, and Oracle databases are supported. The settings which allow Troggle to send email, necessary to verify users who are setting up accounts, are also in the same file, and allow any SMTP mail server to be used. This allows Troggle to send emails from almost all commercial email services, as well as progressive free email services such as Gmail, because these e-mail services provide SMTP access.

To customize the appearance of the Troggle Web site as presented to users, it is generally sufficient to modify the file `base.html`, and the Cascading Style Sheet which it references. In Django terms, all of the other templates “extend” `base.html` (Table 1). The other templates only

serve to replace “blocks” in `base.html` with content. Table `FIXTHIS` shows the various blocks with a description of what they represent. The location of `base.html` and all other template files is specified in `localsettings.py`, in the variable `TEMPLATE_DIRS`, which is a tuple of strings that are absolute paths to the directory or directories where templates are stored. The style sheet used by `base.html` is stored under the “`css`” directory of the path specified in `MEDIA_ROOT` and must be served at the URL specified in `MEDIA_URL`.

Custom modules are easy to add to Troggle. For example, CUCC’s Troggle installation has a folder called `Parsers` which contains scripts for importing data from our legacy data structure (the system of csv tables described above) into the database using the Django API. If your expedition has a similar data structure to import from, these parsers can be replaced with your own. One of the parsers, `survex.py`, imports from `Survex` files. To use survey data in other formats, such as `Compass` or `CMAPS`, a new parser would need to be written.

CUCC intends to use Troggle on our expeditions for many years to come, and to continue expanding and improving Troggle’s capabilities. Some of the expected improvements include integration with `Tunnel` for in-browser cave cartography, addition of `OpenLayers`-based interactive maps to display caves and entrance locations, and the ability to export a simple HTML tree for offline use. Cooperation from other interested expeditions in its testing

and development is welcomed. To get involved, please visit <http://abouttroggle.cavingexpedition.com>.

Acknowledgements

Troggle began as a joint effort between Martin Green, Julian Todd, and myself. For years, there had been discussion regarding a new paradigm for data management on the expedition, and it was Martin who introduced the idea of a Django project. Julian Todd’s Web programming and scraping experience was invaluable for many of the views and the logbook parsing. Logbook formats for each year of the expedition are different, but thanks to Becca Lawson’s hard work cleaning up and standardizing past logbook files and Julian’s year by year parser coding, we now have over a decade of trips in the database. I would also like to thank Vic Brown and Andrew Waddington for their helpful accounts of the data management techniques they used on early CUCC expeditions, going back to 1976.

References

Software discussed in the text can be accessed via the following Web sites:

`Survex`: <http://survex.com/>

`Tunnel`: <http://www.freesteel.co.uk/wiki/index.php/Tunnel>

`Django`: <http://www.djangoproject.com/>

`Python`: <http://www.python.org/>

`Troggle`: <http://abouttroggle.cavingexpedition.com/>

`OpenLayers`: <http://openlayers.org/>

Block name	Purpose
<code>title</code>	The title of the page, to be displayed at the top of the browser.
<code>head</code>	Holds elements that need to be inside the HTML <code><head></code> tag, such as metadata and scripts.
<code>logininfo</code>	This is used to display “welcome,” “log in,” or “sign up” links. Should not be replaced by “extending” templates.
<code>nav</code>	Used for child templates, such as the “virtual survey binder,” that include a lefthand menu.
<code>contentheader</code>	The header for the actual information being displayed.
<code>content</code>	The actual information being displayed.
<code>footer</code>	Content at the footer of the page. Should not be replaced by “extending” templates.

Table 1. Template blocks specified in `base.html`, which provide the framework for inserting content into Troggle’s Web interfaces.

CAVE INVENTORY SITUATION IN CENTRAL AMERICA

FERDINANDO DIDONNA¹, CARLOS GOICOECHEA¹, GUSTAVO QUESADA¹, and ANDRES ULLOA²

¹Project ICEKE Instituto Centroamericano de Estudios Kársticos y Espeleológicos

PO Box 4729-1000, San José, Costa Rica, proiceke@gmail.com

²Universidad de Costa Rica

The Central American region has a great historical and environmental heritage: its caves, its underground environments, and its karst territories. At the present time, there is no regional institution that handles exploration, recording and protection of this natural heritage of such great importance for future generations.

The idea of a regional and transversal institute took force during the First Seminar on Sustainable Management of Karst Land held in Cobán, Guatemala, from June 16–19, 2003. On this occasion, a declaration of attempts was signed, in which it was recognized the importance of the study of karst systems in relation to the sustainable development of the communities of those areas. It was at the 1st Central American Congress of Speleology, held in 2006 at Catacamas, Honduras, where the speleological groups of Central America (CA) that attended consolidated their interests in joining together in Project ICEKE (*Instituto Centroamericano de Estudios Kársticos y Espeleológicos*) to support the first steps that consisted of standardizing all cave and karst records, plus the centralization of a database for Central America. Since the 1980s Costa Rica has had an inventory of caves held by Carlos Goicoechea and has published it as RKN (*Registro Karstico Nacional*). This inventory of caves is based on a cave numeration and identification through a detailed and ordered description, using an alphanumeric identification code that includes province and a unique cave identity number. Also included in the RKN are geological and biological aspects of each cave identified.

For the rest of the region, excluding Belize, the cave inventories are practically nonexistent; they only exist in a fragmented form within cave exploration reports or in foreign speleological groups' records. This situation was rectified in 2006 during the first Central America Speleological Congress where the ICEKE started to define guidelines for the regional cave inventory. At the same time, in Costa Rica, the GEA (*Grupo Espeleológico Anthros*) started to use a freeware software program produced by the Belgian speleologist Paul De Bie. The software, SPELEOBASE, is a data base system that allows registering and organizing caves with a series of data entries with such cave detail information as pictures, maps, etc. A Spanish version has now been produced by ICEKE, in conjunction with Mr. De Bie, for use as the official data base for cave inventory in Central America.

In this time we have created national codes for the cave identification and the number of sites registered per country is: Belize 74, Costa Rica 255, El Salvador 2, Guatemala 21, Nicaragua 5, Panama 47, and Honduras 120. It is clear that the number of caves discovered in the region is more than that registered in the system, but the project is in the early phase in the region. For this reason, the ICEKE is organizing a series of workshop for the use of SPELEOBASE among the cavers in our region.

1. The origin of the Project: the National Karst Register (RKN).

A cave inventory may be the most important asset that a caving group or organization has in order to achieve an efficient and productive knowledge for the protection and conservation of the caves and their environments. *Cadastré* is the word by which we generally designate a “*pattern*” or archive. These *patterns* can be related to real state,

intellectual property, vehicles and many other areas such as cave or subterranean spaces.

In our case in Costa Rica, it was believed necessary to create a “*site*” to write down and register all of the data related to caves, caverns, pits, etc. of our country; in other words, almost all of the features of the branch of geology known as karst phenomena, whose regular practice we know as

speleology or caving. This idea took its first steps around the year 1970, but because of the lack of an adequate program, it didn't go past being "loose data annotated in loose sheets."

By 1994 we found the need to give each known *cavity* a *Registry Number* to go alongside its name and annotated on a particular list kept by one caver. Additionally, the country was divided into seven karst areas as follows: Guanacaste (1), Central Pacific (2), Central Valley & Vicinities (3), Turrialba & West Atlantic (4), Atlantic (5), South Pacific (6) and Isolated (7) (Goicoechea, 1993).

This manner of grouping is still used today, but we now use the Prefix CR and a "key" made strictly of numbers to identify each cave. In the old system, first came the group number, followed by a letter that identified the sub-group, then the cave's I.D. number, and finally a capital letter that identified the province. An example: 1.C.a.1-A. This one was Gabinarraca (or Venado) Cave. In this particular case an extra "a" was introduced to identify a specific Locality. The capital "A" indicated it is in the province of Alajuela. Luckily, not a single initial letter of the names of Costa Rica's provinces is repeated. This RKN was held directly by Carlos Goicoechea and the Grupo Espeleológico Anthros (GEA), it consisted of a paper sheet collection published in few exemplars and represented a milestone in the cave inventory of Costa Rica.

In 2005 the GEA decide to start using the program SpeleoBase for an upgrade of the paper inventory. The decision to use this program was made based on the fact that this software is freeware, designed by a caver, with a very complete and self-sufficient system that allows an intelligent indexing of caves and pits, that is to say, exactly what we needed.

This program is a "Data Distribution/Storage Base," that offers a general list by country, and then, when you enter each specific cavity, has a pre-designed form that in six pages brings out absolutely everything that has been said about that cave: cave name and number, history, description, location, how to get to it, geology, hydrology, rigging, topography, photography, general documents and all the maps that have been done, etc. We started using the English version and, for the time being, there are 255 caves registered in Costa Rica (including four "general zone sheets," covering minor cavities that lack exact locations). There is another classification entered as "Costa Rica: Unknown", where details on "suspected caves" is entered (19 extra files so far).

All files and publications have been digitalized and included in the RKN. The next step in this project considers marking

all major cave entrances with small metal plaques with the RKN ID sequential number. This project requires a lot of work and resources to visit all caves within the country.

2. The Central American Institute of Karst & Speleological Studies (ICEKE) and the Cave Inventory

The idea of a regional and transversal institute took force during the *First Seminar on Sustainable Management of Karst Lands*, held in Cobán, Guatemala, from June 16 to 19, 2003. On this occasion a declaration of attempts was signed, in which the importance of the study of karst systems was recognized in relation to the sustainable development of the communities of those areas. It was at the *1st Central American Congress of Speleology*, in 2006, at Talgua, Honduras (GEA, 2006), where the speleological Central American groups (Fig. 1), as well as those of the Dominican Republic and Puerto Rico consolidated their interests of joining to create the *Central American Institute of Karst & Speleological Studies (ICEKE)* and to support the first steps, that consisted of standardizing all karst and cave records, plus the creation of a database for Central America and the Caribbean.



Figure 1: Participants 1st Central American Congress of Speleology, 2006.

For Project ICEKE, speleology is a scientific research activity that investigates karst and subterranean world focused on the direct correlation of many disciplines, such as geology, hydrology, paleontology, archaeology, anthropology, biology, physics and microbiology, among others.

Project ICEKE's mission is to be a scientific institution responsible for investigating karst areas and the subterranean environment in Central America, in order to protect and promote the sustainable management of these natural sites. For Project ICEKE, the karst environment is a territory marked by the dissolution of limestone rocks resulting in a series of geological and environmental processes that create

very special natural landscapes that remarkably influence the culture and lives of the people that live in those areas.

The main objectives of Project ICEKE are:

1. Activate and obtain legal status of the ICEKE.
2. Study the karst and subterranean sites of Central America (CA).
3. Constitute and managing the cave and karst inventory of CA.
4. Develop speleological activities in CA.
5. Impulse the sustainable management of the caves which are open to the public in CA.
6. Promote speleological education and diffusion at formal and informal levels.
7. Maintain the official relationship with regional and international nature conservancy organizations.
8. Organize and promote academic activities, congresses, and workshops related to cave protection in CA.

In this first stage, the ICEKE is based on a network of organizations (Table 1) and has been received support from the IUCN/WCPA Task Force on Caves and Karst for the project of monitoring and assessing caves which are open to the public. The ICEKE network meets during the Central American Congress of Speleology and also uses the Internet in many virtual conferences. ICEKE also has an open blog page www.proiceke.blogspot.com to stimulate activities and promote cave protection projects in the region.

The cave inventory is actually the main objective of ICEKE, which has been working on a register of caves, Central American Cave Register (*Registro Centroamericano de*

Cavernas, RCC), using the SpeleoBase program emulating the experience of the GEA. Project ICEKE has been urging all caving groups and individual speleologists of the area to use SpeleoBase for registering their explorations and also to directly register their data in the main data base.

Taking into consideration the potential of this database and the use that it can represent for Latin American speleologists, In 2008 (Didonna and Quesda, 2008), GEA and ICEKE along with the program's creator, Paul De Bie, committed themselves to translating the whole program and generating a new version in Spanish which can be downloaded for free from the homepage of GEA: www.anthros.org and from the Avalon web site www.scavalon.be. This version is available for all the Latin American caving groups that wish to standardize their registries and integrate with the main database of caves of Latin America.

SpeleoBase is more than a database, is a great program for recording and managing data on caves, widely used by speleologists all over the world. Some of its tools enable users to register more than 50 different fields, from the name of the cave to records of coordinates, description, literature, and information about cave rigging and other topics. The table of records can be organized in many ways. It allows the use and creation of filters. In addition, each record can be linked to images, drawings, documents (Word, PDF, MPEG, JPG, etc.) and to websites. It has a powerful search engine that operates with any given keyword. For printing purposes, it allows you to print detailed records of each cave or selected listings of caves, in the order selected and in accordance with the set up filters.

This system is so friendly that lets you send records of one or more caves by E-mail to other SpeleoBase users and/or

to selected cavers, with or without pictures or related documents, thus allowing for efficient sharing of information and the ability to generate data base backups, no matter the administrator's location. The generation of export files is compatible with global positioning system receivers for navigation and even with Google Earth.

SpeleoBase allows standardization of the

Country	Organization	National cave register
Belize	Department of Archaeology	Yes
Costa Rica	GEA (Grupo Espeleológico ANTHROS)	Yes (RKN)
El Salvador	GEO (Grupo Espeleológico Oztot)	No
Guatemala	INGUAT ASOKARST Universidad de San Carlos Guatemala	No
Honduras	UEH (Unión Espeleológica de Honduras)	No
Nicaragua	GEA (Grupo Espeleológico ANTHROS)	No
Panama	Smith. Trop. Res. Inst NSS	Yes
Dominican Republic	Espeleogrupo de Santo Domingo	Yes
Not Central American	University of Wisconsin-Milwaukee	-

Table 1: ICEKE member organizations.

records of caves in all given countries, as well as forcing explorers “to register” a lot of important information for multiple disciplines complementary to caving, thus becoming a reference database for future scientific studies. The translation of this program from English to Spanish has been an excellent tool for the improvement of the two inventory projects in our region: the RKN of Costa Rica, as well as the RCC.

All the information available about caves explored in Guatemala, Belize, Honduras, El Salvador, Nicaragua, Costa Rica and Panama, has been collected from diverse sources and entered in the RCC. The first big set of data was collected from secondary information sources (speleological groups, cavers, and other organizations) that participated in the 1st Central American Caving Congress, celebrated in Honduras during the year 2006.

Currently, there are a total of 524 caves recorded by the Project ICEKE just in Central America, which are detailed in the Table 2 by country. Of course, the number of caves registered doesn't correspond to the real number of caves known or explored in each country due to the fact that many records are still not published or available.

3. The Project ICEKE Approach for the RCC

Project ICEKE is demonstrating that a dynamic approach to the promotion of regional organization is the best way to stimulate activities and attention on speleology. This dynamic approach will lead to a multilevel stream of organization in order to ensure better diffusion of cave knowledge and promotion of cave conservancy. The RCC opened cave files with very little information and few references in order to start a process of identification and

verification of the data as well as a research process the team collaboration of the RCC. This processes itself is the hard work that the RCC has carried on since 2003.

Different actions have been promoted by Project ICEKE (congresses, courses, meetings with local institutions, etc.) but education is the key line. The use of SpeleoBase has promoted the organization of workshops for cavers and other people interested in cave protection in our region; the aim is create a standard use of SpeleoBase software and a multilevel register in the region.

The information is entered into the RCC's database, under a “confidential” status, but keeping the source of data's origin. If there is a request for information by a third party for scientific purposes, the ICEKE network will assess the application and will contact the author to obtain prior approval before sharing such information with a third party.

The philosophy of Project ICEKE is based on constant evolution and adaptation to changes in the region's speleological community that is constantly growing at various levels, including the technical level and in local governance due also to the cooperation that GEA has carried on in the last five years.

4. Conclusions

A cave inventory is a process in which much energy has to be put in to obtain results. Project ICEKE and GEA are devoting their clerical activities to insert data in the karst inventory and by advocating, promoting, and supporting the project at different levels.

In Guatemala we have started a tourist cave inventory as

Country	Number of Caves	Longest Cave	Deepest Cave
Belize	74	Chiquibul System*(97 km)	Actún Box Ch'iich' (-183 m)
Costa Rica	255	La Bruja-Rectángulo-Corredores System (6 km)	La Serpiente Dormida Cave (-169 m)
El Salvador	2	Caverna Encanto (121 m)	Caverna Encanto (-15 m)
Guatemala	21	K'an Ba Cave (3 mm)	Sacmoc Cave (-70 m)
Honduras	120	Quebrada de Susmay Cave (6.7 km)	Sumidero de Maigual (-430 m) *
Nicaragua	5	Cueva de Murciélago (150 m)	Cueva del Murciélago (-17 m)
Panama	47	Ol' Bank Underworld (1,146 m)	Hueco de los Duendes (-22 m)
Notes:			
1- (*): longest or deepest cave.			
2- Costa Rica has another 19 caves inscribed as “Undetermined.”			
3- The grand totala for Central America currently stands at 524 inscribed caves.			

Table 2: Summary of ICEKE cave data by country.

the base for a national cave inventory connected to the regional one. It is clear this dynamic system of various level inputs is providing genuine information. The contribution of past caving expeditions and actual cave research are very important and many datasets are still in different location and the convergence in a unified framework is required. A system of data control and field verification is already started on RCC to create a transparent flux of data input and output.

For all those cavers wishing to share their information, even if on a very confidential basis, and to make it available to future studies and research knowing that beforehand their permission as copyright owner will be asked, please consider the RCC. The contact reference is GEA-ICEKE: proiceke@gmail.com. The RCC has also established a protocol of consultation based on these principles.

Acknowledgements

Our sincere thanks to Paul De Bie for his wit and friendship, as well as for placing at the service of the Latin caving world this first class tool.

The making of this RCC registry has also counted on the enthusiastic participation of: Richard Finch (NSS), Guido Baroncini, Andrea Benassi and Michele Sivelli (Italian Cavers), the Honduras Speleological Union UEH, Keith Christenson (NSS) for Panama, the cavers from Costa Rica, and many others from different countries.

References:

- Didonna F. and G. Quesada (2008) *NOTICIAS DESDE CENTROAMÉRICA: Instituto Centroamericano de Estudios Kársticos y Espeleológicos*, Espeleo Informe Costa Rica Año 2 – No 3 – Junio 2008 San José, PO Box 4729-1000 informe@anthros.org
- Goicoechea C. (1993) Registro Karstico Nacional. Colección “*Cavernas de Costa Rica*” N. 6 San José Costa Rica.
- Grupo Espeleológico Anthros (2006). *Memoria: 1er Congreso Centroamericano de Espeleología*. Catacamas, Honduras. April 2006.

CREATION OF AN INTERNATIONAL DIGITAL KARST DATABASE AND AN INTERACTIVE WORLDWIDE MAP OF KARST

EMILY HOLLINGSWORTH¹, VAN BRAHANA¹, ETHAN INLANDER², MICHAEL E. SLAY²

¹Department of Geosciences, University of Arkansas, Fayetteville, Arkansas 72701

²The Nature Conservancy, 675 North Lollar Lane, Fayetteville, Arkansas 72701

Historically, many people dealing with caves and karst have tended to be very guarded about sharing information. They have sought to protect their property, resources, liability risk, and special interests by keeping details about karst (especially caves) secret. This has resulted in inconsistent, localized, and hard-to-access knowledge and data, with highly generalized large-scale maps of widely varying consistency and quality. The most pervasive problem is a general lack of understanding about the complexity, science, and fragile nature of many of these unique settings. Obviously, individual cave locations need to be restricted on a need-to-know basis. However the need to accurately characterize areas having potential to develop near-surface karst is becoming increasingly urgent as humans expand land-use practices into fragile settings that jeopardize rare and irreplaceable karst resources.

An effort to create an international karst database has been initiated by the University of Arkansas and The Nature Conservancy of Arkansas. The objectives of this project are: (1) to create Geographic Information Systems (GIS) databases that include known studies, published and unpublished, of major aspects of karst; and (2) to refine and interactively update large-scale maps with the most accurate delineation of known and potential karst regions throughout the world. Objective 1 will include geologic, hydrologic, speleogenetic, biologic, and ecologic data layers, including documentation citations and a relative ranking of accuracy. Data-base architecture will allow the addition of layers as warranted. Input access and database modification will be limited, pending documentation and verification of specific recommendations for revision. The database is to be available to appropriate karst stakeholders. Objective 2 will be based on combining the latest and most accurate maps with refined karst distribution based on GIS manipulation of the databases generated in Objective 1. Both objectives will be based on existing data, although project design allows for continual updating. The project could later include new projects focusing on specific areas or types of data. With the cooperation of the scientific community, the database will be updated and expanded as new information is collected.

An underlying motive for this project, and the impetus for involvement by The Nature Conservancy, is to advance the protection of karst species and habitats globally. Ranking and delineation of areas of environmental and ecological sensitivity can be achieved by blending detailed data described previously with maps of anticipated land-use change and studies of risk assessment of endangered and threatened species. Addressing karst conservation and identification is indispensable at a global scale, owing to the importance of karst habitats for biodiversity, and is equally important for karst-resource management. There is currently no global karst biodiversity database. The proposed global karst GIS database will (1) fill this data gap, (2) provide a starting point for future protection of karst habitats and species, and (3) provide a valuable interactive set of tools for a broad range of needs for all karst stakeholders.

1. Introduction

Comprehensive scientific understanding of karst is a recent phenomenon; for the most part, most major understanding and technological breakthroughs have come during the last 150 years, with most rigorous, quantitative developments limited to the last 50 years (Ford and Williams, 2007).

Disciplines contributing understanding have been diverse (Culver, 1982; Davies et al., 1984; Culver, 1999; Hamilton-

Smith, 1997; Gunn, 2004; Culver and White, 2005; Florea et al., 2005; Struckmeier, 2006; Juinhua et al., 2007; and Hollingsworth, 2009) and varying methods of study and non-uniform terminology have not facilitated cross-discipline communication.

Mapping of karst features has long been an important tool for karst scientists, but typically mapping has only been

undertaken at a local or regional scale (Epstein et al., 2002; Weary, 2005; Jianhua et al., 2007; Hollingsworth, 2009, where karst resources are extremely valuable, where karst hazards are significant, or where managers and scientists have unique, long-range visionary plans for these resources. As a result, national, multinational, continental-scale, or world-scale karst maps are incomplete, highly variable in accuracy, and generally poor representations of the distribution of karst regions of the world (KROW). Considering the fact that karst settings are reported to cover from 12 to 25 percent of the land surface of the earth (White, 1988; Veni et al., 2001; Culver and White, 2005; Gunn, 2004; Ford and Williams, 2007); including parts of all continents, and a huge range of topographic, physiographic, land-use, and climatic settings, the scant attention paid to lack of worldwide karst mapping seems inappropriate, and ripe for change for many reasons.

Unfortunately, lack of precise delineation of KROW has restricted the ability of all karst stakeholders, especially conservationists, to manage resources, plan for development, and address threats to karst ecosystems. Recognizing the need for such information, The Nature Conservancy (TNC) of Arkansas and the University of Arkansas (U of A) are working to build an interactive, meaningful karst database, and from this database, to accurately map KROW. TNC is challenging scientists and researchers to more thoroughly study subterranean habitats to help establish ecosystems evaluation tools to prioritize karst conservation efforts across the globe. Karst areas are underrepresented in globally protected areas, adding urgency to the development of tools to support conservation; in fact, TNC currently does not include karst as one of their main habitat types on earth. Although TNC has as a goal to advance the protection of karst species and habitats globally, the products generated by this report have application throughout those sub-disciplines of our science that requires large-scale mapping, and accurate karst-boundary delineation at country-wide or larger scales.

2. Methodology

Following the approach of Veni (2002), this study has divided KROW into three broad categories, carbonate, evaporite, and pseudokarst. Carbonate and evaporite karst were distinguished from one another because of the major differences in water quality created by rock-water interaction in these settings, and pseudokarst was distinguished from the other two because its process of formation is so completely different from dissolution-formed karst. All types contribute to similar subsurface ecosystems, but each has the potential to harbor a distinct group of organisms

based on unique physical and chemical attributes of lithology and mode of formation. The distinction between buried and surface karst was determined to be outside the scope of the overarching needs of TNC.

Known cave and karst features were inventoried and integrated into a GIS, consisting of a spatial database, a set of three supplemental data tables relating the reference information to the database, and maps representing KROW. Collectively the digital products and the datasets do not represent a single map, but rather serve as a dataset to generate a variety of karst-related maps. ArcMap 9.2 and ArcInfo GIS and mapping software were chosen as the spatial analysis, visualization, and spatial data-management tool for KROW. Digital data were presented as ARC/INFO export files and ArcView shapefiles fitted to a common set of global, country and state boundaries.

The database was constructed by acquiring digital versions of existing karst maps and digitizing existing printed maps and raster images with cooperation of the area's stakeholders. Digital-processing techniques were applied for data visualization, enhancement, and interpretation of multiple geodata sets. When digital geologic maps were accessible they were incorporated into the database for analysis of karst areas to generate preliminary regional scale work maps. Within continents, further subdivision by country, state, region, and local area were undertaken as necessary to adequately delineate the preliminary karst boundaries based on geology maps.

Karst distribution was cataloged in the KROW Database (KROWD) and assigned shape categories for each classification type. Individual polygons were assigned distribution attributes: karst ID, karst type, size in km², shape length, and location by continent and countries. The digital karst representation was tied to supplemental karst data of specific documentation regarding map scale, display attributes, analysis properties, map use, data source, and relevant annotations. When the spatial databases were merged, these tables were made accessible through the GIS by pointing at locations on the map. Once the database was completed and data were standardized, general statistics were computed on each of the variables; range, mean, and standard deviation were obtained. In addition, an analysis was completed to determine if any patterns were evident within the datasets of each of the variables.

3. Results

Relationships based on position and areal distribution of karst phenomena were considered and evaluated in a

Region	% Carbonate	% Evaporite	% Pseudokarst	Total % of Karst Cover
Russia Federation	17.87	0.00	0.00	17.87
South America	2.80	0.09	1.43	4.31
Africa	8.10	0.16	2.23	10.49
North America	15.14	0.30	0.88	16.31
East & South East Asia	17.15	0.00	1.11	18.27
Middle East & Central Asia	19.32	0.06	1.60	20.97
Europe	21.60	1.63	0.30	23.54
Australasia	5.34	0.00	1.47	6.81
World	12.52	0.18	1.40	14.10

Table 1: Percentage of eight regional-scale subareas of the Earth's surface covered by three types of karst (carbonate, evaporite, and pseudokarst), modified after Hollingsworth (2009). The table is keyed to Figure 1.

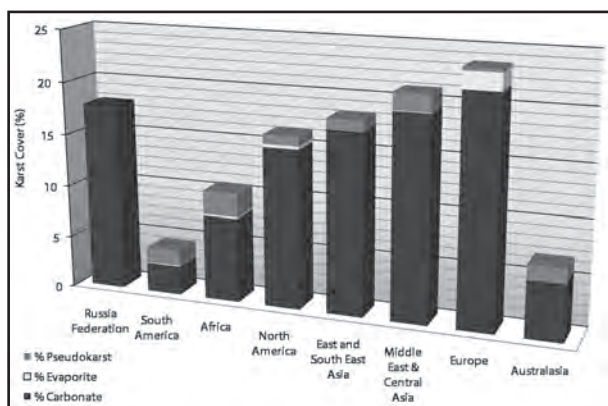

Figure 1: Graph showing percentage of eight regional-scale subareas of the Earth's surface covered by three types of karst (carbonate, evaporite, and pseudokarst), modified after Hollingsworth (2009). The graph is keyed to Table 1.

statistical framework, providing information on the number, area, and percentage of land cover of carbonate, evaporite, and pseudokarst polygons for each continent and the world (Table 1). Following the methodology of Ford and Williams (2007) calculations (v.3.0) for the area of the world carbonate outcrops, the world was divided into a regional classification for comparison of area estimations (Table 1 and Fig. 1). The continental-scale subdivisions include: Russian Federation Plus, South America, Africa, North America (excluding Greenland), East and South-east Asia, Middle East and Central Asia, Europe (excluding Iceland and Russia), and Australasia. The distribution of karst of the world is shown in Figure 2, as are the rectangular boundaries of the continental-scale subareas.

4. Conclusions

The compilation of existing data and maps into a global

karst database ultimately will include geologic, hydrologic, speleogenetic, biologic, and ecologic data layers, including documentation citations and a relative ranking of accuracy. Currently, the emphasis has been on geologic, with some biologic and ecologic input where such data are easily accessible. Database architecture allows the addition of layers as warranted. Although input access and database

modification will require documentation and verification, access and use of database is envisioned to be open to all appropriate karst stakeholders. Worldwide and eight regional-scale maps have been based on combining the latest and most accurate extant maps with refined karst distribution based on GIS manipulation of the databases generated. Obviously, this database and the maps generated are not intended to be a final product, but rather, an early step in drawing the entire cave and karst community into a necessary, worthwhile, and strongly needed effort.

References

- Culver, D.C. (1982) *Cave life: Evolution and Ecology*. Harvard University Press, Cambridge, MA, 223 pp.
- Culver, D.C., (1999) *Ecosystem and Species Diversity Beneath Our Feet* : in Ricketts, T.H., Dinerstein, Eric, Olson, David, Loucks, Colby, Eichbaum, William, DellaSalla, Dominick, Kavanagh, Kevin, Hedao, Prashant, Hurley, Patrick, Carney, Karen, Abell, Robin, and Walters, Steven, eds., *Terrestrial Ecoregions of North America. A Conservation Assessment*. Island Press, Washington, DC, pp. 56–60.
- Culver, D.C. and W.B. White, (2005) *Encyclopedia of Caves*. Elsevier Academic Press, Burlington, MA, 654 pp.
- Davies, W.E., J.H. Simpson, G.C. Ohlmacher, W.S. Kirk, and E.G. Newton, (1984) *Engineering aspects of karst*. U.S. Geological Survey National Atlas, scale 1:7,500,000.

Epstein, J.B., D.J. Weary, R.C. Orndorff, Z.C. Bailey, and

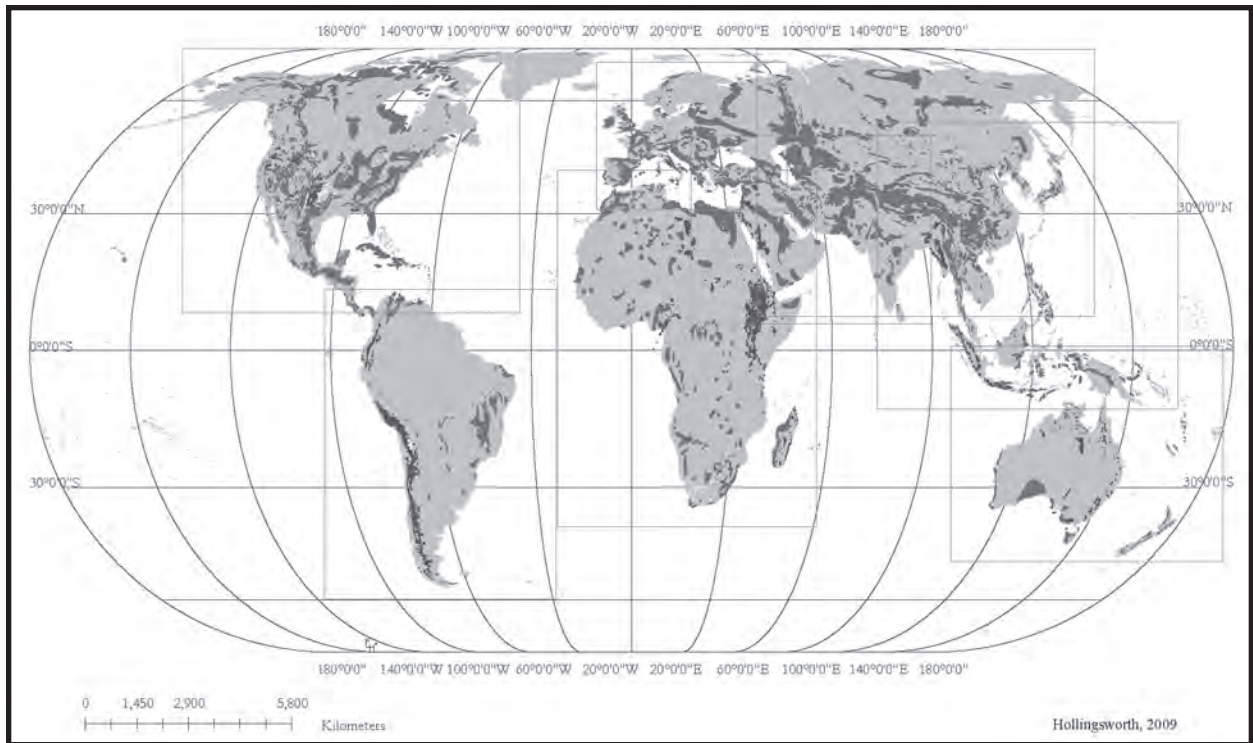

Figure 2: Map showing karst regions of the world (KROW) with regional-scale subareas delineated by rectangles. Land masses are shown in light gray, carbonate karst is represented as dark gray, evaporite karst is represented as white, and pseudokarst is represented as black (after Hollingsworth, 2009).

- R.C. Kerbo, (2002) National Karst Map Project; an Update: U.S. Geological Survey Karst Interest Group Proceedings, Shepherdstown, West Virginia. U.S. Geological Survey, Report Water-Resources Investigations Report 02-4174, pp 43–44
- Florea, L.J., B. Fratesi, and T. Chaves, (2005) The reflection of karst in the online mirror: A survey within scientific databases, 1960-2005. *Journal of Cave and Karst Studies*, **69**:1, pp 229–236.
- Ford, D.C. and P.W. Williams, (2007) *Karst Hydrogeology and Geomorphology*. Wiley Chichester, London, 2nd ed., 576 pp.
- Gunn, J. (2004) *Encyclopedia of Caves and Karst Science*. Fitzroy Dearborn, New York, 902 pp.
- Hamilton-Smith, E. (1997) The IUCN Guidelines for Cave and Karst Protection: Report Proceedings of the 1997 Karst and Cave Management Symposium, 82 pp.
- Hollingsworth, E. (2009) Karst regions of the world (KROW)—Populating global karst datasets and generating maps to advance the understanding of karst occurrence and protection of karst species and habitats worldwide. Unpublished M.S. thesis, University of Arkansas, 115 pp.
- Jianhua, C., Z. Daoxian, Z. Cheng, and J. Zhongcheng, (2007) Karst ecosystem of Guangxi Zuang Autonomous Region Constrained by Geological Setting: Relationship between carbonate rock exposure and vegetation coverage, in International Conference on Karst Hydrogeology and Ecosystems, Hoffman Environmental Research Institute, pp 15–16.
- Struckmeier, W. (2006) The world-wide hydrogeological mapping and assessment programme (WHYMAP) and the world-wide hydrogeological map information system (WHYMIS): International Association of Hydrogeology Commission on Hydrogeological Maps, Hannover, Germany.
- Veni, G (2002) Revising the karst map of the United States. *Journal of Cave and Karst Studies*, **64** (1), pp 45–50.
- Veni, G., H. DuChene, N.C. Crawford, C.G. Groves, G.N. Huppert, E.H. Kastning, R. Olson, and B.J. Wheeler, (2001) *Living with Karst- A Fragile Foundation*. American Geological Institute

Environmental Awareness Series 4, Alexandria, VA, 64 pp.

Weary, D.J. (2005) An Appalachian regional karst map and progress towards a new National karst map: *in* E.L. Kuniansky, ed., U.S. Geological Survey Karst

Interest Group Proceedings. U.S. Geological Survey Scientific Investigations Report 2005-5160, pp 93–102.

White, W.B. (1988) *Geomorphology and hydrology of karst terrains*. Oxford University Press, New York, 464 pp.

THE WORK OF THE UIS INFORMATICS COMMISSION

PETER MATTHEWS

President, Informatics Commission, International Union of Speleology. <http://www.uisic.uis-speleo.org> matthews@melbpc.org.au

This paper summarizes the ongoing work of the UIS Informatics Commission (UISIC). Established in 1986, it aims to encourage and facilitate the systematic collection and responsible use of cave, karst and related data on an international basis.

The Commission's main working groups are currently Data Exchange, Survey & Mapping, Multi-lingual Dictionary, and recently, Documentation Standards. Data Exchange includes data field definitions (currently about 680), example table structures, technical and format requirements for data exchange, and subject categories; the web-based Australian Karst Index Database is a current open-source example using these definitions. Where possible, code numbers are used for field values so they are independent of language and can be translated on the fly. Survey & Mapping formulates standards via international discussion, and has so far established basic cave mapping symbols and surface mapping symbols. Multi-lingual Dictionary publishes speleological terms in multiple languages, with so far about 340 terms in nine languages. Documentation Standards, working in collaboration with the Karst Information Portal, aims to publish recommended minimum standards for cave and karst documentation.

Further projects awaiting attention include a library of format modules for the above data fields for synthesizing data entry forms; expanding on the list of fields by inviting karst scientists to contribute field definitions related to their own discipline; open source software for national cave/karst databases (building on the Australian example), and for field recording of detailed data during expeditions and its later presentation; a web-based database where expeditions will be invited to reference and archive summary data; and a web page linking to useful examples and tips for cave and karst documentation.

As usual, the Commission runs a website and forum, and volunteers to help with the work are most welcome. A contact list summarizes data repositories and interested people in each country.

1. Introduction

The Informatics Commission (1) was formed as part of the International Union of Speleology (2) just over 20 years ago in 1986. Its aims are to encourage and facilitate the systematic collection and responsible use of cave and karst data on an international basis.

The aim of this paper is to acquaint you with the work of the commission so you can see whether it could help with any of your own projects, to promote an interest in documentation standards, and even perhaps encourage you to help the commission with its work.

One of the main thrusts of this work has been to produce standards to facilitate the exchange, comparison, consolidation and/or analysis of cave and karst data between independent databases. To this end the commission has prepared a proposal (3) which sets out the necessary conditions to allow this, and has established a data dictionary or repository containing draft definitions

for nearly 700 data fields, together with a range of recommended values for those of the fields which can use a fixed vocabulary.

An aspect which the commission is very mindful of is that its standards should as much as possible be independent of any particular language. To this end wherever possible we have used numeric codes to identify fields and their values. In use, these codes can be translated to any language, for example, on computer screens they can be translated into the desired language on the fly. One of our web pages shows the numeric field value codes in both English and German. During discussions we use English, then once items are agreed, we try to have them translated into as many other languages as possible.

The fields are shown on the commission's website, and international discussion and hopefully acceptance of them will be starting by the time of this International Congress of Speleology. We will be using a web forum for the

discussions, where everyone interested can join in, then with final voting by one delegate per interested country. The new international *Karst Information Portal* (KIP) has similar aims, and so we plan to collaborate. The KIP (4) is all about providing integrated access to scattered cave and karst data, and providing a framework to encourage and assist collaboration between karst workers.

As you will see below, there is a lot to be done, so to help these projects produce results in a timely manner we do need more volunteers. If you would like to help, or just find out more about the projects, please contact me.

Currently our main working groups and projects, active and planned, are:

- the data exchange standard:
 - field definitions
 - transfer format and conversion program
 - web-based fields repository
 - library of field layouts for paper data entry forms
- speleological subject classification scheme
- minimum cave documentation standards
- multi-lingual word list
- cave survey & mapping standards
- open-source cave database software
- web-based cave database for expedition summary data
- a method for field capturing, storing and presentation of expedition data
- assistance to the European Cave Protection Commission with their European karst areas GIS

2. Working Groups and Projects

2.1 Data exchange standard

The commission has produced a proposal document (3) which sets out what is needed to allow valid cave and karst data exchange. Basically these are:

- Unique record IDs
- Agreed field definitions
- An agreed transfer format

2.2 Unique record IDs

This is to allow database records and their foreign key linkages to be copied to other databases without clashing with any existing records. To enable any data producer to assign these IDs to their records without having to refer to any central coordinator we are recommending a record ID structure like this example: "AUVSA00037", where "AU" is

the 2-letter ISO country code of the record creator, VSA is the organization's agreed 3-letter code within that country, and "00037" is the serial number for that particular record.

2.3 Agreed field definitions

Currently we have about 700 draft data fields in our repository for handling data related to caves and karst. Many of these have come from Australia's already established web-based national cave and karst database (5,6), so we know they work. They are therefore being used as the starting point for our discussions to establish internationally agreed field definitions. Many more fields will be needed to cover the various caving, scientific, management, and protection aspects of course, so these will be added as they become available. We will be inviting workers in the various karst sciences to contribute field definitions related to their discipline, and similarly with cave management fields. If you are already operating a cave/karst database, you are invited to make contact to show what fields you are using and why, so that we can look to incorporating them also into our central repository. Proper attribution would be given of course. Currently our field definitions are stored in a PC-based database management system, which also generates the web pages displaying the definitions.

To help illustrate how the fields could be used, and how a cave/karst database could be constructed, we have web page diagrams which give a range of example database table structures. Currently we show example table structures for caves and karst features, maps, data quality and security, and data history and attribution, with more to come.

This part of the exchange standard currently has these sub-tasks:

- Discuss and set the agreed definitions - we need to be sure the draft fields are suitable for international use.
- Convert the PC-based repository to a web-based one, to allow distributed updating by specialist working groups.
- Create a library of HTML-based field layouts for assembling and printing paper data-entry forms. We are using HTML because it is platform-independent, and these HTML text files will be easily adapted to local conditions.

2.4 An agreed transfer format

This is a text file independent of any database software or structure and contains the data to be transferred (or compared or consolidated or analyzed) between

independent databases. It can also of course be used to archive data independently of any platform or software. Although such a cave data transfer format is known to have existed and worked successfully with the Australian database since 1985, today we feel such a transfer file should be based on XML (*Extensible Markup Language*) and its associated standards. Our working group (7) for this started out using cave survey data as its pilot, but the requirements for cave survey data proved to be too difficult, so we plan to restart the working group using just “ordinary” cave data, and try cave survey data again later when enthusiasm returns. The name we are using for this format or markup language is *CaveXML*.

Associated with the transfer file itself will be a text file at each end to describe the local database structure at that end, and a UISIC-supplied program which, for sending, creates the XML transfer file from comma-separated-value (CSV) files which have been exported from the source database, and for receiving, creates CSV files from the transfer file. Because virtually all database systems can export and import CSV files, we have only to write a single program to do the conversions to and from these CSV files. As a text processing program, it will probably be written in Perl, and so should work on all the usual platforms.

2.5 Subject classifications

With thousand of fields expected eventually in the repository, it will be very helpful to be able to group them into subject categories so that the existence of a field for any particular usage can be found more easily. So all the existing fields have been categorized according to a preliminary speleo subject classification scheme (8) which we created, based on that used by the UIS Bibliography Commission for *Speleological Abstracts* (9). However this scheme still has some problems, so we need to create a better one. Such a scheme will of course have many other uses in speleology besides classifying data fields.

2.6 Documentation standards

This new project aims to set out minimum recommended standards for cave and karst documentation. It was suggested by the KIP and so we will be collaborating with them. It will obviously assist with international searches for, and use of, cave and karst information. Obviously much of our existing work would contribute to it. All ideas welcome!

2.7 Multi-lingual dictionary

This working group has built on the original multi-lingual speleo dictionary with four languages published in hardcopy by Attila Kósa of Hungary in 1997. With Attila, we

converted it to a web-based version (10), and subsequently he added another four languages before he died in 2003. It now has 340 speleo “concepts” in nine languages (Croatian, English, French, German, Hungarian, Italian, Portuguese, Romanian, and Spanish), with more on the horizon. Planned improvements are more languages, more concepts, and categorizing the concepts into speleo subject groups. Eventually we might even be able to put meanings against the concepts! Whole new languages or corrections to the existing are very welcome!

2.8 Survey & mapping standards

The Survey & Mapping Working Group (11) has already established international standards for basic cave mapping symbols and for karst surface symbols, and is now addressing grades for survey and mapping. As usual, anyone can get involved in the discussions, and final voting is by a formal delegate from each interested country.

2.9 Cave database software

The aim is to make available free, open-source, web-based database software (for Internet or local use) for caves, karst, and related entities, and which can integrate with GIS software. It would implement UISIC’s proposed standards of course. It is planned to build on the open-source software (5) developed by the Australian Speleological Federation (ASF) (12), and which already uses many of our draft fields. Currently this stores data about the following entities: caves and karst features, karst areas, maps, people and organizations. Expected future additions include bibliographic references, biological species, and cave minerals.

2.10 International cave/karst database

This project aims to provide a web-based cave/karst database accessible via the Internet. Its main focus is to provide a central location to store summary details from expeditions, recording especially where the detailed data from the expedition can currently be found. It could also be used by countries to make their cave data more accessible if there is no suitable database available locally, or even if there is. Again, it would be developed from ASF’s open-source software and use the UIS standard fields.

2.11 Handling expedition data

The consolidation and day-to-day on-site use and presentation of data from multiple parties during caving expeditions to remote areas presents its own set of problems. This project aims to suggest methods and provide tools to assist with this, initially based on Australian experience during various remote area expeditions.

2.12 European karst areas GIS

The European Cave Protection Commission (13) is preparing a GIS map comparing European karst areas with existing protected areas in their push for EU protection of all European karst areas. This new project aims to help the Commission where possible. The data fields and techniques gained during this project should of course be useful to other countries.

3. Other Resources

As would be expected, the Commission operates a website (1) and web forums. Apart from pages related to the above projects, the site also contains a contact list and a documentation news page. A planned new page will link to practical examples of cave and karst documentation techniques from around the world. At this symposium I am also presenting a poster paper which illustrates some of the work above.

4. Conclusions

The tools are now available to allow much better collaboration and access to cave and karst data from around the world for better exploration, research, conservation and management. We need to use these tools to produce systems which make it happen. So there is lots of work to be done, but few to do it. We need your help and ideas.

Acknowledgements

Over many years many people from around the world have contributed their effort, skills and knowledge to enable us to be where we are now. It's impossible to include everyone, but you can get part of an idea from the web pages for the dictionary, survey and CaveXML working groups. Special thanks also go to Mike Lake of ASF, who has provided invaluable ongoing assistance in discussions about new data fields for our fields repository.

References

1. UIS Informatics Commission (UISIC): <http://www.uisic.uis-speleo.org>
2. International Union of Speleology (UIS): <http://www.uis-speleo.org>
3. Cave Data Exchange Proposal: <http://www.uisic.uis-speleo.org/exchange/exchprop.html>
4. Karst Information Portal (KIP). Introduction: <http://www.uisic.uis-speleo.org/kipintro.html>. Website: <http://www.karstportal.org>
5. Australian Karst Index Database (KID) website: <http://www.caves.org.au/kid>
6. LAKE, M. and MATTHEWS, P. (2005) An Open-source Web-based National Cave Database. *Paper to the 14th International Congress of Speleology, Greece, 26 Aug 2005*: <http://www.uisic.uis-speleo.org/exchange/kidpaper2005.html>
7. Cave Data Exchange Working Group: <http://www.cavexml.uis-speleo.org>
8. Speleological Subject Classification scheme: <http://www.uisic.uis-speleo.org/exchange/sscintro.html>
9. *UIS Speleo Abstracts*: <http://www.isska.ch/bbs>
10. The Caver's Multi-Lingual Dictionary: <http://www.uisic.uis-speleo.org/lexintro.html>
11. Survey and Mapping Working Group: <http://www.uisic.uis-speleo.org/wgsurmap.html>
12. Australian Speleological Federation (ASF): <http://www.caves.org.au>
13. European Cave Protection Commission: http://fsue.ffspeleo.fr/commission/protection/index_commission.htm

EXAMPLES OF UIS INFORMATICS COMMISSION WORK*PETER MATTHEWS**President, Informatics Commission, International Union of Speleology. matthews@melbpc.org.au***Abstract**

This poster shows examples of some of the work of the UIS Informatics Commission (<http://www.uisic.uis-speleo.org>). Illustrated are an example of table structures for the cave and karst feature entity of a cave database, field definitions and field value codes, subject classifications, data entry form, multi-lingual speleo terms, and mapping symbols.

THE TEXAS SPELEOLOGICAL SURVEY: 48 YEARS OF DATA GATHERING

RON RALPH

President, Texas Speleological Survey

13101 Wild Turkey Drive, Manchaca, Texas 78652

The Texas Speleological Survey (TSS) is a nonprofit corporation dedicated to the management of Texas cave data in support of research, exploration, education, and conservation. It was founded in 1961, and formalized itself with a Board of Directors (now 15-members) in 1994 and nonprofit status in 1995. The TSS office, housed at The University of Texas at Austin, with support through the Texas Memorial Museum, has produced or co-produced 40 publications on Texas caving regions, plus Kentucky and New Mexico. As of January 2009, 9,500 records are in the digital database, of which 4,379 are caves, 2,687 are karst springs, 233 are rockshelters, and 1,282 are sinkholes and other karst features. Hundreds of additional paper documents concerning caves and karst features are being recorded digitally from our extensive files. Access to the data is available through casual requests, where non-sensitive or small amounts of sensitive data are requested (a simple procedure most commonly used by cavers) and formal requests, where large amounts of sensitive data are requested or greater assurance for responsible use is needed (a written request used mostly by consultants). Each method includes procedures to assure, as much as possible, the proper use of the data, protection of cave and karst resources, and the return of new data to TSS. The TSS also has an extensive photo and video archive, exchange newsletters and other publications in a lending library, artwork and other cave-related ephemera, and a “museum” of equipment and other items.

The Texas Speleological survey strives to support Texas cavers and caving projects, while generating information for its database, through timely publications, a regular column in the Texas Speleological Association’s newsletter, data-cataloguing sessions, projects, workshops, and our Web site: http://www.utexas.edu/tmm/sponsored_sites/tss/index.html

1. Introduction

Cave surveys serve the caving community by compiling maps, survey data, exploration notes, scientific data, and locational/ownership data for the various areas. The mission of the Texas Speleological Survey (TSS) is to collect Texas cave and karst data, and to organize the data to support science, education, conservation, and exploration. This is accomplished through written and electronic data gathering from Texas cavers as individuals and as team players in organized projects. Projects are run by the Texas Speleological Association (a pan-Texas group), grottos, and individuals. The TSS usually acts as the clearinghouse for reports and notes for projects.

2. History

The TSS began as a collection of cave files in the 1950s by various Texas caving groups. The University of Texas (UT) Grotto files, begun as a collection of index cards by Bob Hudson, grew as others began to contribute. Don Widener of the Dallas Speleological Society started the “Texas Cave Survey,” publishing eight county reports in 1957-1958 drawing on NSS Bulletin 10, *The Caves of Texas*

(Mohr, 1948), and the files of the UT, Corpus Christi, St. Mary’s, and Abilene grottos, as wells as from Mills Tandy, A. Richard Smith, and other cavers. In the late 1950s, Bill Russell and James Reddell became active and began to systematically map and study caves.

In 1961, Reddell and Russell started the TSS and published a 13-page checklist of 646 Texas caves. Ruben “Bud” Frank became the TSS staff geologist and A. Richard Smith the staff cartographer. Another eight reports were issued as Vol. I from 1961 to 1963, which included Travis, Uvalde, Bexar, San Saba, and Val Verde counties as well as the Langtry area, Northwest Texas, another state cave list, and an index.

TSS Vol. II was published from 1963–1966 and covered Williamson, Comal, Bell, Coryell, Edwards, and Kinney counties, plus paleontology and a 1966 state list. This list went onto computer punch cards and became TSS’s first database. In 1967, A. Richard Smith became editor publishing Vol. III from 1967–1973. It included Medina, Lubbock, Kimble, and San Saba counties, along with the Stockton Plateau, a bibliography, a key to bats, and an index.

Editors and writers included Smith, Reddell, Carl Kunath, and Tony Mollhagen.

By the mid 1970s, the TSS was nearly inactive, but editors Ronnie Fieseler and Reddell turned out Vol. IV on Brewster and western Pecos counties (with Kunath) and Far West Texas. This culminated with the publication in 1978 of *The Caves of McKittrick Hill, Eddy County, New Mexico*, by Kunath, and the U.S. National Speleological Society (NSS) Convention Guidebook, *An Introduction to the Caves of Texas* (Fieseler et al., 1978), an excellent overview which became the basic reference on the subject for 16 years.

After the 1978 NSS Convention, momentum was lost until Bill Elliott moved to Austin in 1982 and helped Reddell revive TSS again. In 1985, Elliott published *A Field Guide to the Caves of Kendall County*, which was first compiled in a database. The volume number scheme was abandoned as TSS planned to publish reports without subscription support but by building up a publication fund from sales. Elliott started a microcomputer database in 1986 by recovering the punch card data that Keith Heuss had safeguarded. Elliott added many more cave records to the files and scoured publications and the files to build a database on cave maps. Meanwhile Reddell computerized his huge Texas speleological bibliographic and North American biospeleological databases, now available as TexBib through a searchable open source software program created by David McKenzie. In 1988, George Veni's massive *The Caves of Bexar County* was published by the Texas Memorial Museum. Increasing computerization led to the publication of *A Field Guide to the Caves of Blanco, Gillespie, and Llano Counties* (Reddell et al., 1989).

In 1994, Elliott and Veni edited *The Caves and Karst of Texas*, a 362-page record-breaking guidebook for the NSS Convention in Brackettville. This book was grounded on the extensive TSS files and is still the best selling publication offered by the TSS. It marked a turning point for the TSS. Its production and publication regenerated and interest in the TSS. The income it generated called for a more secure means of handling the funds and presented previously unavailable opportunities. By the end of the year, TSS formally organized with officers and a board of directors. Reddell secured three rooms from the Texas Memorial Museum for TSS use, and status as a non-profit corporation was received in 1995.

A Web site was announced in 1996; the culmination of many years of thought. The Web site continues to evolve with visitation climbing each year. Different sections let

you explore all facets of the organization including on-line data submittal and data requests. The listing of the longest and deepest caves in Texas is kept current by Butch Fralia, our database manager, while he also maintains the website. Publication sales begin on the web with a listing of available reports, and purchases are made via check sent to the sales manager. And of course, brisk sales are realized at caver functions throughout the state and on special occasions, such as NSS conventions, and are planned for the International Congress of Speleology.

3. Board of Directors

Our 15-member Board of Directors meets quarterly to attend to the affairs of the organization. This working Board also writes most of the publications, seeks donations of labor, equipment and cash, paints the wall, and cleans the restrooms. Without their tireless labor, the organization would cease to exist. All labor is by volunteers and there is no paid staff.

4. Computers

Computer hardware and software needs are continuously growing and replacements are often met through individual donations and grant support. We have seven computers, with five linked for ease of transfer and to allow access to the printer and scanners. A copy machine works overtime to keep up with the demand by cavers and volunteers. Software is written, purchased or donated and the total package is kept working by David McKenzie, our information technology wizard.

5. Database

The TSS has always been about collecting cave data and sharing it freely with cavers. Beginning in the 1990s, a new group of consumers began to emerge. People with different agendas began requesting not just data of one or two caves but on whole blocks of land. For some, the goal was not to study, preserve and protect the cave resources but to satisfy state or federal requirements for environmental inventory and impact mitigation. Some of these folks were often interested in minimizing the importance of caves in order to begin construction projects that would harm or destroy them. Others, like some state and municipal agencies wished to protect caves as areas crucial to groundwater supplies and as habitat for endangered species. As requests for information became more demanding, the TSS began changing its data access policy to protect the sensitive data and still allow access to those who both needed it and would use it responsibly. The TSS data release policy grew out of discussions between directors at open meetings where the TSS goals of supporting "scientific, educational, and

conservation purposes, with the specific objectives to collect, organize, and maintain information on Texas caves and karst, and to generally make that information available to responsible persons and organizations” as stated in the bylaws. On the other hand, the TSS reserved the right “not to distribute certain information if it could result in the exploitation or degradation of cave or karst resources.” Formal data requests are reviewed by the Data Manager and then sent to all officers for review. The request is granted if there is no objection. This insures a reasonable and timely approach to “responsible persons and organizations.”

6. Data managers

Data management is divided by Texas’ counties and regions, depending on the interest and availability of directors and other volunteers who are focused on studying those areas and maintaining their information. These data managers assemble the files as data are received, create paper files for standard file cabinets, scan and file maps in the flat files, and generate electronic data sheets which are submitted to the state-wide data manager who assigns a permanent county identifier and enters the cave into the master file. These county identifiers consist of a three-letter county code followed by a sequential three-digit number beginning with 001. This allows the database, created in Microsoft Access, to sort by 70 different criteria. The database currently has 9,612 entries and has grown steadily since records were first kept (Table 1). A new project is underway to create a linked system using WallsMap, where by one can select a cave on a statewide map and go directly to the database entries to find a cave map, photographs, a biology list, and other data.

7. Memoranda of Understanding

Through memoranda of understanding, the TSS gathers,

Texas Speleological Survey Data	January 2009	January 2005
Database Records:	9612	6322
Caves:	4379	3719
Sinks/features:	1524	993
Shelters:	262	201
Springs:	2816	142
Aesthetic:	77	N/A
Archeological:	179	88
Bad Air:	210	N/A
Bats:	184	N/A
Biological:	344	N/A
Endangered Species:	144	N/A
Geological:	70	N/A
Historical:	64	51
Hydrological:	118	N/A
Paleontological:	94	69
Lost Caves:	1331	N/A
Surveyed:	1611	N/A
Rumored:	271	231
Undefined:	323	1075
Records with UTM Locations:	7171	N/A
Records with Topo plot, no UTM:	1109	N/A
Counties with Karst Records:	208	N/A

Table 1: Data statistics from 2005 compared to this year. Note that more systematic recording has been added over the years.

records, and holds cave data for a federal organization (National Park Service – Amistad National Recreation Area), state agency (Texas Parks and Wildlife Department) and municipal entity (Barton Springs/Edwards Aquifer Conservation District). We not only organize and sometimes lead inventory projects on public lands, we record and curate thousands of files for these governmental bodies. Our non-profit status gives us refuge from the Freedom of Information Act and encourages governmental agencies and landowners alike to deposit sensitive information at our office in the J.J. Pickle Research Campus of the University of Texas. There, we house photographs, maps, notes, cave locations, ownership information, and certain memorabilia from historic caving groups and individuals. The data are kept two ways; as general information available to cavers and for authorized users of proprietary data that requires owner permission before viewing or using. Locked and fireproof file cabinets house this documentation.

8. Urban Corridor

Texas is growing rapidly with most development (residential, businesses, and factories) restricted to the major cities' suburbs and along the edge of the Balcones Escarpment both east and west of the Interstate Highway 35. This so-called urban corridor, at least on the limestone western part, extends over karst and caves. Because these developments are required by law to inventory properties for cultural resources, threatened and endangered species, wetlands and other concerns, engineering and consulting environmental firms come to the TSS for cave data. The TSS has streamlined their data request procedure to deal in a timely manner with these businesses. In return, the TSS receives reports on newly discovered caves and karst features which we enter into the database as open or proprietary information.

9. Map files

The bulk of our maps are in standard-size file drawers along with descriptions and other data. Oversized maps are placed in flat files between acid free leaves. Very large maps are rolled and placed in tubes. We have an agreement with the Texas Parks and Wildlife Department to use their digital scanner for maps up to four-feet wide and use it when we organize a new batch from the files. Maps too large to scan are taken to a commercial business to copy and scan.

10. Library

TSS has a lending library which contains books, journals, newsletters, pamphlets, and reprinted articles focusing on Texas caves and caving. A librarian enters each of our holdings into a database with a string of keywords for a search engine. The library includes newsletters from Texas, the United States, and many other parts of the world. Scientific reports on archeology, geology, paleontology, groundwater along with a filing cabinet full of scientific reprints make up the bulk of the library. A simple sign-out sheet suffices to keep track of withdrawals and returns.

11. Publications

Book sales are the economic backbone that supports our publication production. At this time, the TSS has 38 publications for sale and several others in press. We also sell 11 other caving publications on Texas, North America, Mexico, Belize, and Guatemala. Over 1,200 cave maps are available for sale on compact disks; most are different caves but a few are several versions of the same caves as mapping continued and the caves grew. Sales from those publications support printing of new reports. Of the 4,400 or so known and recorded caves in Texas, the TSS has now published almost 3,500 pages and 2,300 maps on the subject (Table 2). County surveys form the bulk of our publications with 68 counties represented in 28 volumes. Paleontology, bats, checklists, and guidebooks make up the other published volumes along with a dozen non-TSS volumes on such varied subjects as out-of-state caves and detailed cave fauna studies from North America and Mexico.

12. TexBib

James Reddell began compiling a bibliography of Texas biospeleology in the late 1960s expanding it to cover all subjects pertaining to Texas caves and caving. TexBib is a searchable bibliographic database for Texas caves. It is

Year	Known Caves	Cave Maps	Cumulative Pages Published
1948	183	9	137
1961	646	85	244
1962	801	156	355
1963	est. 1000	263	538
1964	est. 1200	307	767
1966	1362	358	908
1968	1600	458	1255
1973	est. 1800	667	1483
1978	est. 2100	825	1759
1989	2482	1091	2336
1994	est. 3000	1328	2698
2005	3719	1575	3402
2009	4379	est 2330	est. 3491

Table 2: The number of known Texas caves continues to rise even though an increasing number are destroyed or degraded. The cumulative number of pages published includes TSS publications and three NSS guidebooks compiled by TSS, but not the Texas Caver or grotto newsletters. Publication of a map compact disk increased the number of published maps substantially. Data are from publications or computer databases ("est." means estimated).

primarily the product of over 40 years of work by Reddell with contributions from other TSS directors. David McKenzie wrote Reselect, the search engine program which is downloadable with the bibliography below. The bibliography can be searched by author, keywords, dates, or combinations. TexBib entries are from all available Texas caving newsletters, plus national and international newsletters, books, science journals, newspapers, magazines, theses, dissertations, and any other published sources TSS can find. TexBib currently contains over 13,000 bibliographic entries dating from 1866 to the present and is regularly updated.

13. Museum

A minor component of the TSS at this time is the curation and display of caving memorabilia.

14. Work Sessions

We conduct work sessions each month where cavers and others can gain access to the cave data and help us organize the files. A tremendous amount of paper files including newsletters, reports, newspaper accounts, private files, photographs, maps and electronic media are processed through the office and filed appropriately. All must be read and copies made if necessary to store in different files. All publications are reviewed for bibliographic references and placed in TexBib, while maps are scanned for inclusion in both county records and for inclusion on the map compact disk.

15. Workshops

We hold workshops to teach mapping, cartography, electronic data management and cave photography. Each workshop is led by a team of specialists in the field accompanied by computer technicians as needed. Workshops are open to all cavers and interested parties and sometimes require nominal charges for materials.

16. Conclusions

With 48 years of data gathering and distribution, the Texas Speleological Survey is one of the oldest and most distinguished caving organizations in the United States. Our philosophy of liberal fellowship and conservative fiscal policy has enabled us to publish high quality cave data while maintaining paper and electronic files for the State of Texas. We hope to be around for another 48 years.

References

- ELLIOTT, W.R., Ed. (1985). A field guide to the caves of Kendall County. *Texas Speleological Survey*, 143 pp.
- FIESELER, R., J. JASEK, and M. JASEK, Eds. (1978) An introduction to the caves of Texas. *Texas Speleological Survey*, NSS Convention Guidebook **19**, 116 pp.
- KUNATH, C.A. (1978) The caves of McKittrick Hill, Eddy County, New Mexico. *Texas Speleological Survey*, 87 pp.
- MOHR, C.E., Ed. (1948) The caves of Texas. *National Speleological Society Bulletin*, **10**, 136 p.
- REDDELL, J.R., W.R. ELLIOTT, and A.R. SMITH, Eds. (1989). A field guide to the caves of Blanco, Gillespie, and Llano counties, Texas. *Texas Speleological Survey*, 133 pp.
- VENI, G. (1988) *The caves of Bexar County*, second edition. Texas Memorial Museum Speleological Monographs, **2**, 300 pp.

A NEW KARST MAP OF THE UNITED STATES

DAVID J. WEARY, DANIEL H. DOCTOR

U.S. Geological Survey, MS 926A National Center, Reston, VA 20192 USA, dweary@usgs.gov

Over the last several years, the U.S. Geological Survey (USGS) has worked toward compiling a new map of karst in the United States in cooperation with the National Cave and Karst Research Institute (NCKRI), the National Speleological Society (NSS), and with contributions by various state geological surveys. The new National Karst Map will replace previous paper maps with a digital, GIS-based product. The digital data will provide significant improvements in precision and utility inherent to spatial data in a GIS environment, as well as some inherent limitations to data applications and interpretations. Our approach to producing a new karst map is to first compile a map of soluble bedrock derived from various data sources, primarily published state and federal geologic maps. In addition, features analogous to karst are presented where geologic information is available to support the delineation of these areas (e.g., volcanic pseudokarst). The potential karst areas are then subdivided based on styles of karstification within the context of the regional setting. In the eastern United States the extent of outcrop of soluble rocks provides a good first-approximation of the distribution of karst-prone areas. Criteria are being developed for further refinement of the map units including the distribution and density of caves, sinkholes, and other karst features. Issues complicating the compilation and classification process include: (1) a lack of coherence in spatial precision and lithologic classification between the various geologic maps; (2) lack of easily obtainable statewide and region-wide karst feature data; and, (3) recognition and quantification of key, non-lithologic factors affecting the development and distribution of karst features. Ongoing work includes delineating areas of pseudokarst in addition to volcanic terrains, and to improve delineation and classification of principal karstic aquifers. Linkage to the Karst Information Portal (KIP) and NCKRI offers a potential framework for integration of the national map to karst data sets of all resolutions from national to local scales.

1. Introduction

The United States spans the North American continent and contains numerous karst landscapes produced under a wide variety of geologic, physiographic, and climatic conditions. Karst landscapes cover more than 20% of the land surface in the United States. As a result, federal government agencies manage, regulate, and protect large areas of karst. As the primary national Earth science agency, the U.S. Geological Survey (USGS) has undertaken a project to produce a new national karst map which can serve a digital karst data layer to the public for multiple uses. Support by the National Cooperative Geologic Mapping Program (NCGMP), National Park Service (NPS), and National Cave and Karst Research Institute (NCKRI) has enabled us to hold several regional workshops, which were attended by representatives from 16 states, the NPS, and other organizations. These meetings have promoted personal communication and dialogue resulting in sharing of data, suggestions for construction of the map, and improved inter-regional perspectives on karst-related issues. The history of the national karst map project can be traced through the presentations made by USGS scientists over the last several years (EPSTEIN et al., 2001; EPSTEIN et al., 2002;

ORNDORFF et al., 2001; ORNDORFF et al., 2002; TOBIN and WEARY, 2004; WEARY, 2005; WEARY, 2006a; WEARY, 2006b; WEARY et al., 2003; WEARY et al., 2004; DOCTOR et al., 2008; WEARY et al., 2008)

2. Progress Toward a New National Karst Map

The USGS published the first national scale map of karst in the United States as part of the National Atlas series at a scale of 1:7,500,000 (DAVIES et al., 1984). This map concentrated on engineering aspects of karst and categorized carbonate karst areas by 1) generalized length and depth of fissures, tubes, and caves; 2) general lithologic type; and 3) geologic structural setting based upon the dip of rock strata. The map also included delineation of areas of evaporite karst as well as “features analogous to karst” (pseudokarst) in volcanic rocks and in areas of unconsolidated sediments. This map has been digitized and is available as graphic and vector GIS data online at: <http://pubs.usgs.gov/of/2004/1352/>.

A regional map of potentially karstic areas of the central and southern Appalachian states has recently been completed as the first stage of the National Karst Map project (WEARY,

2008). This GIS-based map is compiled from state and regional bedrock geologic maps, as well as maps related specifically to karst published by state geologic surveys where available. Map elements were compiled as polygons at a scale of 1:1,000,000 precluding resolution of discrete karst features. Potentially karstic areas were divided into seven "karst types" based primarily on rock character defined by lithology and level of induration or metamorphic grade, and secondarily on geologic/physiographic setting, large scale structural regime, and thickness of glacially derived sedimentary overburden. The text accompanying the map contains an explanation of methodology, references to data sources, and a state by state discussion of karst areas, potentially karstic stratigraphic units, karst studies at the state level, and descriptions of notable caving areas and caving activities. The data for this map are available online at: <http://pubs.usgs.gov/of/2008/1154/>.

A preliminary map of potentially karstic areas of the conterminous United States, based primarily on state-scale (1:24,000 up to 1:1,000,000) geologic maps, has been constructed (Fig. 1). This map reflects the presence of soluble bedrock lithologies (i.e., carbonate and evaporite rocks), and young (mid-Tertiary) extrusive volcanic rocks of low viscosity. These are the most important lithologic factors for developing karst or volcanic pseudokarst. Lava

tube caves are predominantly found in rocks younger than about 40 million years old (PALMER, 2007; KOLEV and SHOPOV, 1992), therefore areas of older volcanic rock have been excluded. Figure 1 is a first approximation of potentially karstic and volcanic pseudokarstic areas based on compilations from state geologic maps.

We are in the process of developing criteria for subdividing these potential karst areas into karst types reflecting regional styles of karstification. Criteria being considered include: geologic setting, physiography, and the distribution and density of caves, sinkholes, and other karst features. Additional criteria such as ecoregions (Fig. 2) and the known geographic distribution of cave organisms are also being considered. The compilation and classification process is complicated by: (1) a lack of coherent spatial precision and classification of lithologic units between various geologic maps; (2) a lack of easily obtainable statewide and region-wide karst data, especially cave locations; and, (3) recognition of key, non-lithologic factors affecting the development and expression of karst features. Delineation of karst areas has been refined in more detail based on interaction with members of the respective state geological surveys, local experts and academicians, and members of the National Speleological Society (NSS). Work is ongoing to refine the extent of potential karst areas for the other western

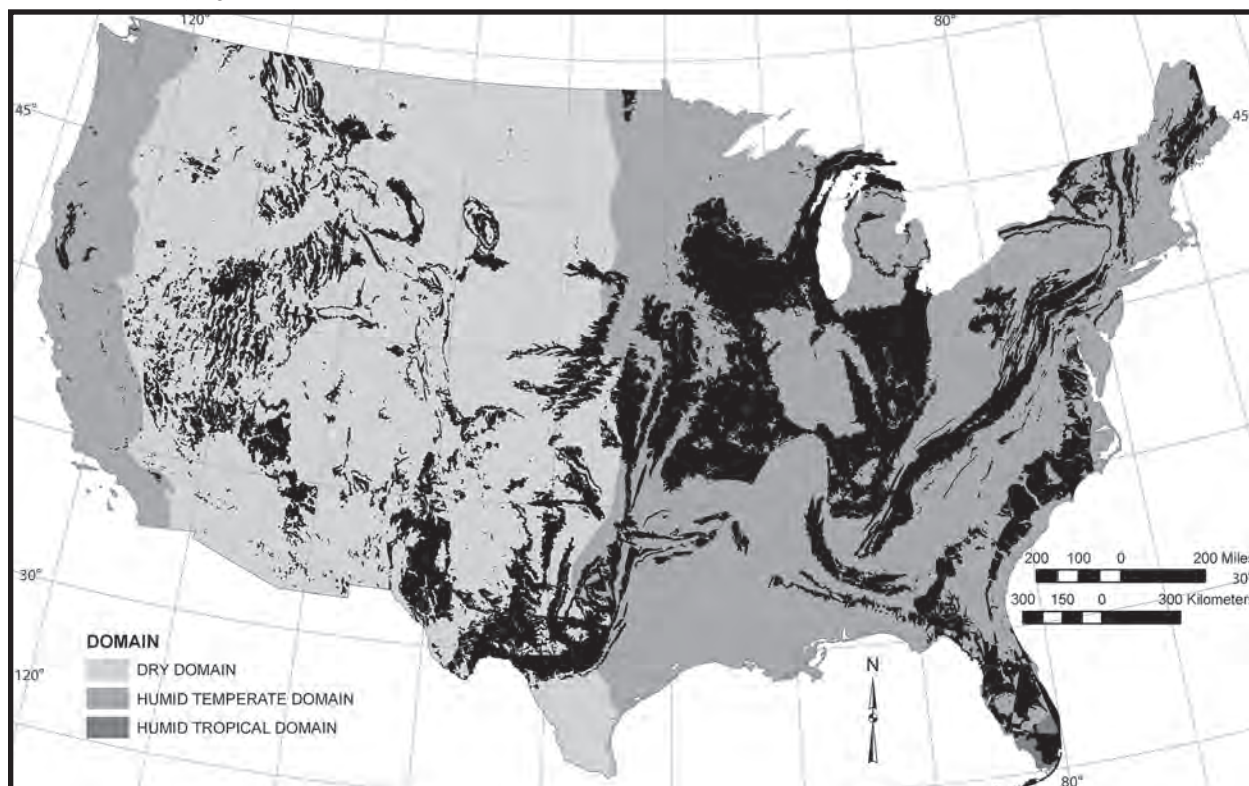

Figure 1: Generalized map of areas of potentially karstic rocks in the conterminous United States. Areas with potential for volcanic pseudokarst also included.

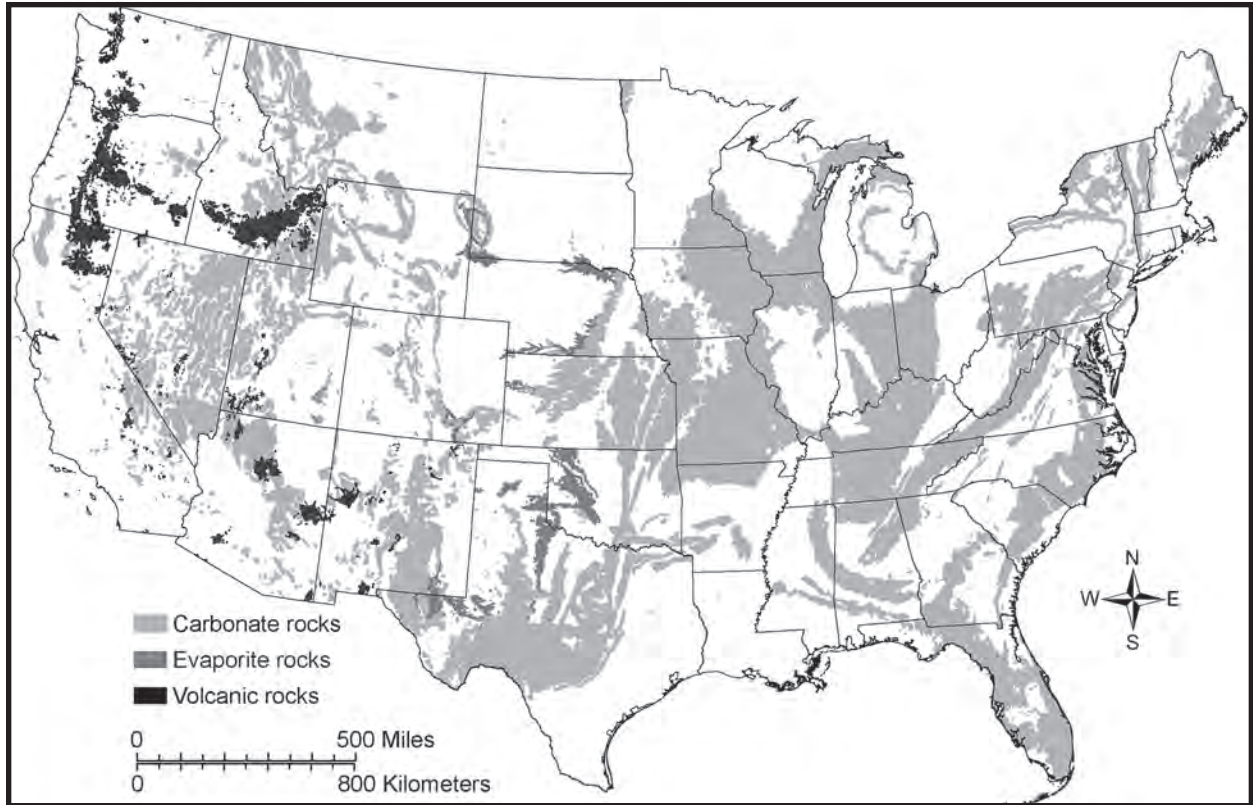

Figure 2: Generalized areas of soluble bedrock (black areas) and ecologic domains of the conterminous United States. The Humid Tropical Domain occurs only in southern Florida.

states, to delineate additional types of pseudokarst, and to estimate the subsurface extent of evaporites that give rise to surface collapse features resulting from solution at depth.

There is a need for placing the karst of the United States, into a hierarchical geographic classification scheme. A system has been suggested (WEARY et al., 2008) that parallels the ecologic classification scheme of BAILEY et al. (1994), which is widely used by natural resource agencies across the country. Such a system would link the karst classification to both physiographic and biological factors in order to establish a framework for organizing karst features and their ecosystem services across multiple scales. Moreover, there are additional needs to classify karst; first, in accordance with the geomorphological processes of karstification, and second in accordance with characteristics of groundwater flow in karst aquifers (DOCTOR et al., 2008; DOCTOR et al., this volume). These various approaches to classification of karst are intended to address the multiple applications of the National Karst Map to land management, water management, and karst research in general.

3. Conclusions

We continue to work in partnership with NCKRI, various

State geological surveys, and other agencies and individuals with karst expertise to refine the accuracy of the map and the utility and veracity of our classification schemes. This map is a dynamic data set that will be continuously modified and updated. Because of its scale and scope, our goal is to have the National Karst Map dataset serve as a gateway resource to other karst databases. We hope that users will be able to use the national map as the top layer in their efforts to drill down into lower, more detailed sources of karst information and data. The new Karst Information Portal (KIP) offers a potential framework for integration of data sets of all resolutions from national to local scales. Linkage to the KIP and NCKRI offers a potential framework for integration of the national map to karst data sets of all resolutions from national to local scales.

References

- BAILEY, R.G., P.E. AVERS, T. KING, W.H. MCNAB, eds. (1994) Ecoregions and subregions of the United States: U.S. Geological Survey, Accompanied by a supplementary table of map unit descriptions compiled and edited by McNab, W.H., and Bailey, R.G., Prepared for the U.S. Department of Agriculture, Forest Service, Scale 1: 7,500,000.

- DAVIES, W.E., J.H.SIMPSON, G.C.OHLMACHER, W.S.KIRK, and E.G.NEWTON, (1984) *Engineering Aspects of Karst*: U.S. Geological Survey, National Atlas, scale 1:7,500,000.
- DOCTOR, D.H., D.J.WEARY, J.B.EPSTEIN, and R.C.ORNDORFF, (2008) A Karst Aquifer Map for the United States—Is it possible?: U.S. Geological Survey Karst Interest Group Proceedings, Bowling Green, Kentucky, May 27–29, 2008, USGS Scientific Investigations Report 2008-5023, pp 34–36.
- DOCTOR, D.H., B.F. SCHWARTZ, and M.O. GARY, (2009) Preliminary development of a quantitative karst classification system, PHORMS. (this volume)
- EPSTEIN, J.B., R.C. ORNDORFF, and D.J. WEARY, (2001) U.S. Geological Survey National Karst Map: National Speleological Society annual convention, Mount Vernon, Ky, program guide p 79, July 2001.
- EPSTEIN, J.B., D.J. WEARY, R.C. ORNDORFF, Z.C. BAILEY, and R.C. KERBO, (2002) National Karst Map Project, an update. *U.S. Geological Survey Karst Interest Group proceedings*: U.S. Geological Survey, Report WRI 02-4174, p 43–44.
- KOLEV, B., and Y. SHOPOV, (1992) Volcanic caves in Bulgaria. *Proceedings of 6th International Symposium on Vulcanospeleology*, National Speleological Society, Huntsville, Alabama, pp 171–175.
- ORNDORFF, R.C., J.B. EPSTEIN, and D.J. WEARY, (2001) Proposed National Atlas Karst Map. *U.S. Geological Survey Karst Interest Group Proceedings*: U.S. Geological Survey, Report: WRI 01-4011, p 46.
- ORNDORFF, R.C., J.B. EPSTEIN, D.J. WEARY, Z.C. BAILEY, and R.K. KERBO, (2002) A National karst map: an update. National Speleological Society annual convention, Camden, Maine, Program and Abstracts, p A-10.
- PALMER, A.N. (2007) *Cave Geology*. Cave Books, Dayton, Ohio, 454 pp.
- TOBIN B.D. and D.J. WEARY (2004) Digital Engineering Aspects of Karst Map: A GIS Version of W.E. Davies, J.H. Simpson, G.C. Ohlmacher, W.S. Kirk, and E.G. Newton, (1984) *Engineering Aspects of Karst*: U.S. Geological Survey, National Atlas of the United States of America, Scale 1:7,500,000, U.S. Geological Survey, Open-file Report 2004-1352 <http://pubs.usgs.gov/of/2004/1352/>.
- WEARY, D.J. (2005) An Appalachian regional karst map and progress towards a new national karst map. *U.S. Geological Survey Karst Interest Group Proceedings*, Rapid City, South Dakota, September 12–15, 2005, Scientific Investigations Report 2005-5160, pp 93–102.
- WEARY, D.J. (2006a) Compilation of national-scale karst data by the U.S. Geological Survey with emphasis on the southeastern United States: Geological Society of America, Abstracts with Programs, **38**, 84.
- WEARY, D.J. (2006b) The national karst map and its relationship to karst feature databases: Annual convention of the National Speleological Society, Program, Bellingham, Washington.
- WEARY, D.J. (2008) Preliminary map of potentially karstic carbonate rocks in the central and southern Appalachian states: U.S. Geological Survey Open-File Report 2008-1154, scale 1:2,000,000. <http://pubs.usgs.gov/of/2008/1154/>.
- WEARY, D.J., D.H. DOCTOR, J.B. EPSTEIN, and R.C. ORNDORFF, (2008) Characterizing regional karst types under the framework of the new national karst map: *U.S. Geological Survey Karst Interest Group Proceedings*, Bowling Green, Kentucky, May 27–29, 2008, USGS Scientific Investigations Report 2008-5023, pp 25–33.
- WEARY, D.J., R.C. ORNDORFF, and W. ALEMANGONZALEZ, (2004) U.S. Geological Survey progress towards a new national karst map: National Speleological Society annual meeting, Marquette, Michigan.
- WEARY, D.J., R.C. ORNDORFF, and J.B. EPSTEIN, 2003, The U.S. National Karst Map Project, Geological Society of America, Abstracts with Programs, **35**, 19–13.

Symposium 7

ISLAND KARST

Arranged by:
John Mylroie
Angel Ginés

ON THE ORIGIN OF DISSOLUTION PIPES

JO DE WAELE¹, STEIN-ERIK LAURITZEN², MARIO PARISE³

¹ *Italian Institute of Speleology, Dipartimento di Scienze della Terra e Geologico-Ambientali. Via Zamboni 67 – 40126 Bologna, Italy, jo.dewaele@unibo.it*

² *Department of Earth Science, University of Bergen. Allegaten 41, N-5007 Bergen, Norway, stein.lauritzen@geo.uib.no*

³ *National Research Council of Italy, IRPI, Bari, Italy m.parise@ba.irpi.cnr.it*

Several perfectly shaped dissolution pipes have been observed and studied in Quaternary coastal calcarenites in Sardinia and Apulia (Italy) and Tunisia. These are cylindrical tubes of 30-110 cm in diameter and up to 970 cm deep with smooth walls along their length but narrowing towards their bottoms. A model has been developed in order to understand their genesis. We believe dissolution pipes are formed by infiltrating water in a covered karst setting. Local patches of vegetation and soil would have enriched infiltrating water with carbon dioxide generating dissolution of carbonate cement and local subsidence. This process would have caused formation of a depression cone that guided infiltrating waters towards these spots giving rise to the downward growth of gravity-controlled dissolution pipes. The loose quartzite sand in these pipes would have been transported elsewhere once the pipes became exposed by erosion of the sediment cover.

1. Introduction

Coastal erosion of Quaternary calcarenites has exposed peculiar karst landforms at Punta Funtanas (Arbus, Central-West Sardinia, Italy), Roca Vecchia, Torre Specchiolla and Torre Santa Sabina (Apulia, Italy) and at Tabarka (Tunisia). The wide set of vertical cigar-shaped pipes found in these coastal areas can be defined as dissolution pipes (Lundberg and Taggart, 1995). These have been reported from many areas in the world and in different climatic and geomorphological settings but essentially from coastal areas in tropical or subtropical climate (e.g. Coetzee, 1975; Herwitz, 1993; White, 1994; Grimes, 2002) and the Mediterranean (e.g. Day, 1928; Delle Rose and Parise, 2003; Marsico et al., 2003). Most of these pipes occur in the surface portion of coastal carbonate-cemented siliciclastic sediments, eogenetic carbonates and in other carbonate rocks with high primary permeability. Their genesis is still the subject of debate and several processes and conditions are thought to be responsible for their development depending on location. This paper deals with the morphological description of the dissolution pipes of the three aforementioned areas and will try to highlight a model for their genesis. This model can be applied for dissolution pipes in Mediterranean climate and in similar geomorphological settings but could also be adapted to other climates.

2. Morphology of Dissolution Pipes

Pipes have been studied in detail in two areas (Sardinia and Apulia, Italy) and general observations included a site along the coast of Tabarka (Tunisia). Some examples of pipes are

shown in Figure 1.

2.1 Sardinia

Dissolution pipes have been found at Punta Funtanas (West Sardinia), where Miocene limestones are covered with Quaternary calcarenites, well-exposed along the coastal cliff. For a detailed description of this area see De Waele et al., 2008. A total of 48 dissolution pipes are found in two areas along the coast, a northern and a southern one, located 200 metres one from another. The pipes have a diameter ranging between 30 and 110 cm and reach depths of 9.7 meters in one exceptional case. Several of these pipes are exposed in the coastal cliff where their longitudinal morphology is clearly visible. They are composed of perfect cylindrical vertical holes apparently not controlled by dip of strata nor fractures, with a classical cone-shaped bottom end (Fig. 1A). Their upper part seems to be controlled by an erosion surface separating two generations of dune deposits. Many pipes have been cut by erosion and their total depth is generally difficult to appraise: mean depth is 310 cm, with minimum of 50 and a maximum of 970 cm. Eighty per cent of the pipes shows a lining of hardened carbonate crust (calcrete or hardpan) of 1-2 cm thickness that is more resistant to erosion and sometimes protrudes from the surface for several centimetres. The largest group of pipes, on the southern outcrop, is composed of thirty pipes, but erosion has partially destroyed most of them and their morphology is less representative. They appear as circular holes, of shallow depth, mostly with a carbonate lining (calcrete). Where visible their bottom has the typical conical shape. The pipes never contained significant sediment

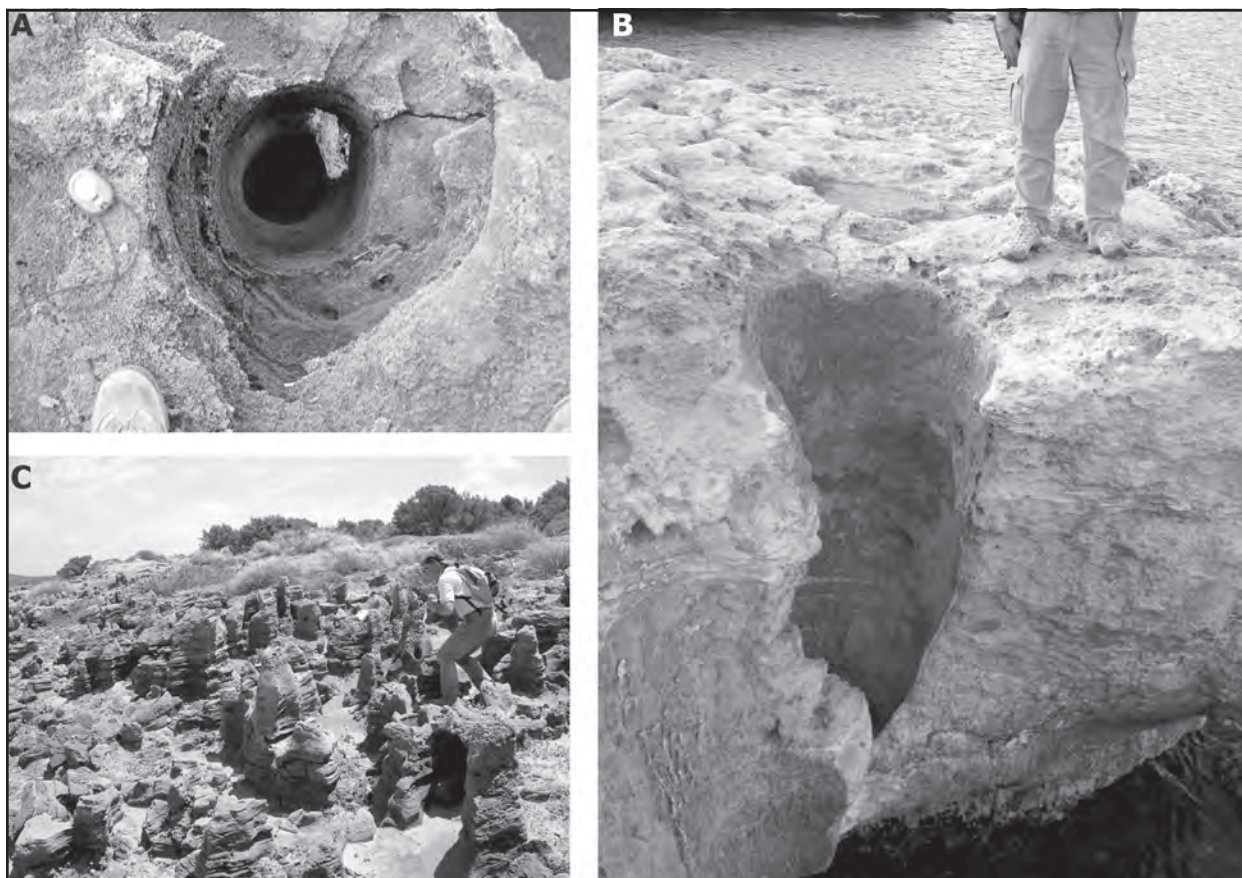

Figure 1: Dissolution pipes: (A) A dissolution pipe with calcrete lining at Punta Funtanas (Sardinia); (B) Dissected pipe with calcrete lining at Roca Vecchia (Apulia); (C) a “field” of pipes along the Tabarka coast (Tunisia).

remains: instead, some of them showed to have well-rounded basaltic pebbles or boulders at their bottoms.

2.2 Apulia

In Apulia (south-eastern Italy) dissolution pipes have been found at several localities along the Adriatic coastline, in the Brindisi and Lecce provinces. Geologically, medium to coarse size, Plio-Pleistocene bioclastic calcarenites, marly calcarenites and calcareous marls represent the main geologic units, resting transgressively over the underlying limestone bedrock of Cretaceous age. An overall number of 200 pipes was analyzed at three sites, the highest number (more than 100) being documented at Torre Specchiolla. The pipes range in diameter between 20 and 155 cm, and reach a maximum depth of 390 cm. The best exposed pipes are located along the few meters-high coastal cliffs where their whole longitudinal section is frequently shown, cut by the sea wave erosion (Fig. 1B). The shape is cylindrical, only locally following joints and fractures in the rock mass. Most of the pipes are filled with silts and fine sands, likely residual deposits; some present sea water, or are partially filled with rubbish. Because of the infilling deposits, the real depth was ascertained only along the coastal cliffs or for those

pipes with no infilling. To our knowledge, only at one site in Apulia pipes were excavated by archaeologists (Blanc and Cardini, 1961), but unfortunately no detailed stratigraphy of the infilling deposits is available. Due to low elevations above sea level, at two out of the three sites object of study, several pipes show direct connection to the sea. More than 90% of the Apulian pipes present a calcrete crust, which thickness locally reaches 5 to 10 cm, often protruding from the surface where the pipes develop. Pipes seem not to be concentrated in groups, but widespread along the coastal area, up to a maximum distance of 30 meters from the coastline. However, local alignments made of three to five pipes have also been observed.

2.3 Tunisia

Dissolution pipes have been documented a couple of kilometres East of Tabarka (Tunisia), where a thick sequence of ancient dune deposits forms a coastal cliff of 10 meters height limiting a 40 meter wide sandy beach. One km eastwards, on an altitude of 3-5 m asl, another patch of carbonate-cemented siliciclastic sediments is exposed by erosion and contains pipes. In the first spot, dissolution pipes are clearly visible in the coastal cliff as longitudinal

sections: they are between 50 and 80 cm wide, and, where visible, taper towards the bottom. The biggest of these pipes have depths reaching 6 to 7 meters. They appear to be clustered in restricted areas, but topsoil and vegetation do not allow a comprehensive overview. Most of the pipes are characterised by the presence of an infilling composed of red clays, certainly derived from the dissolution of carbonate rocks in the head or in topsoil. In the second occurrence pipes are packed closely together almost forming a sort of “pinnacle karst,” with a surface area of about 100 m² containing over 40 pipes (Fig. 1C). They have average diameter of 60 cm and are very much conical in shape. They seem to represent the lower part of a set of dissolution pipes of which the upper portion has been removed by erosion. Their subaerial exposure has modified their shape, creating rounded surfaces, clearly showing they have been exposed for quite some time.

3. Possible Mechanisms for Dissolution Pipe Formation

The genesis of dissolution pipes is still a matter of discussion among scientists and many theories have been advanced since their first descriptions. In the earliest days these so perfect vertical cylindrical holes were believed to have been made by man, also because they were sometimes related to sepulchral archaeological sites. But soon geologists noted that this relation with archaeology was only a casual coincidence and, since these landforms were always hosted in carbonate-cemented sediments their origin was soon connected to some kind of dissolution process (Day, 1928).

One of the main requisites for dissolution pipe formation seems to be the high primary permeability of the host-rock and the presence of carbonate (as cement or as grains). Almost all the described deep cylindrical and smooth-walled pipes occur in coastal calcarenites, both dune- and beach deposits, with at least 50% of carbonate (Coetzee, 1975), although this does not seem to be a fundamental prerequisite (Lundberg And Taggart, 1995). Several authors believed that the regular shape of these pipes should be connected to tree stumps (“palmetto stumps”) (Livingston, 1944) but the very high density of the pipes and the lack of direct evidence soon discarded this syn-depositional hypothesis. The dissolution hypothesis has been clearly proved for similar pipes in Cornwall where internal sediment was mostly composed of decalcified sands (West, 1973). It is in fact difficult to explain the extremely regular pipes found in many places by other processes in hard rocks, such as a deepening of solution pans by phytokarstic processes (Coetzee, 1975; Delle Rose and Parise, 2003), shallow phreatic dissolution by mixing waters close to sea

level creating so-called “banana holes” like the ones found in the Bahamas (Harris et al., 1995) or pothole formation by rolling boulders or “grinders.” These last theories can be excluded because of the morphology of the pipes, with a diameter/depth ratio far too small in comparison to banana holes and potholes found in rivers.

Focussed infiltration flow has to be invoked to make the formation of deep pipes possible. This can be obtained by surface topographical irregularities, mostly containing vegetation patches and soils that would acidify the penetrating waters, creating thus convergent and aggressive infiltration (Spencer, 1981) or by stemflow from long-lived trees or subsequent generations of trees funnelling large quantities of acidified water down their trunks and thus creating localised subsurface dissolution (Herwitz, 1993).

To explain the aggressiveness of the funnelling water also in depth the presence of vegetation and soil seems to be extremely important, as suggested by many authors (e.g. Grimes, 2002). The carbonate that is dissolved tends to precipitate close to the roots and the CO₂-providing soils forming rhizocretions and hardpans. These calcrete crusts are typical in coastal calcarenites, especially in regions with intense precipitation periods followed by long drought (James, 1972). Underneath these crusts the percolation becomes more concentrated and vertical and would create the typical pipes, dissolving carbonates in the pipe and simultaneously cementing the surrounding sands (Grimes, 2002). This, ultimately, would lead to the formation of the smooth carbonate lining found in many of the pipes observed at Punta Funtanas and in Apulia.

4. A Plausible Model for Pipe Growth

It has previously been demonstrated (Milanovic, 1981) that the penetration depth of karst (and other surface weathering features) which develop from an exposed surface into a rock mass can be described by an exponential distribution law. The *Milanovic Distribution*, i.e. an exponential decay of karst void density with depth from the surface, also applies to doline depths (Troester et al., 1984; White, 1988), micro-phytokarst, grikes, and some caves (Lauritzen, 2005)

$$\theta(z) = \theta_0 e^{-kz} \quad \text{with } k = v_D / \kappa$$

Where θ_0 and $\theta(z)$ are depth density at the surface and at depth z , respectively, k decay constant and z depth from the surface, v_D is the surface denudation rate (L t⁻¹), and κ the karst diffusion constant (t L⁻²). The characteristic penetration depth may be expressed as the half-depth, $z_{1/2} = \ln 2 / k = \ln 2 \kappa v_D^{-1}$ (Lauritzen, 2005). This strongly suggests

a diffusion-type of growth from a moving (denuding) surface boundary and is similar to the development of weathering skin on other rocks (Hoke and Turcotte, 2002).

A plot of $\ln(\theta(z)/\theta_0)$ as a function of z would yield a straight line with slope k if the distribution is exponential. If z is normalized with respect to $z_{1/2}$, i.e. $D = z/z_{1/2}$, all distributions where D is substituted for z should plot on the same straight line with slope $\pm \ln 2$, regardless of absolute size (Lauritzen, 2005).

The solution pipes also display properties characteristic for weathering phenomena developing from an exposed surface. First, they are all connected to the karst surface, and where they are exposed laterally by erosion, no remnants of isolated pipes that are clearly not connected to the surface are observed. Second, there are numerous short pipes and correspondingly fewer deep ones. This suggests that they grow by a similar diffusion mechanism as other surface-related karst forms, so they should also be described by a similar exponential distribution law.

Summary data on pipes of Sardinia and Apulia are reported in Table 1. The limited dataset of Tabarka pipes was not analysed. Sorted samples of pipe depths from each site were collected, ranked and plotted semi-logarithmically against depth (Fig. 2). A linear regression line was fitted to the data, the slope of which is the decay constant k (L^{-1}). The results

show that dissolution pipes of the Sardinian and Apulian sites can be described by a *Milanovic distribution*.

5. Conclusions

Dissolution pipes from Sardinia and Apulia have been formed by a downward gravity-controlled diffusion mechanism. They form in a covered karst setting in porous rocks with carbonate cement by diffusion of infiltrating water that acquired acidity at surface. Local patches of vegetation and soil were probably important for the creation of privileged spots in which pipes developed underground. Surface dissolution of carbonate cement would have enhanced permeability with the formation of a depression cone that guided infiltrating waters towards few spots giving rise to the downward growth of gravity-controlled dissolution pipes. The loose quartzite sand in these pipes would have been transported elsewhere once the pipes became exposed by erosion of the sediment cover.

Such a mechanism is consistent with a statistical and morphometric analysis of the pipes. The results show that dissolution pipes of the Sardinian and Apulian sites can be described by a *Milanovic distribution*, i.e. an exponential decay of karst void density with depth from the surface.

Further analysis of the stratigraphy of the infilling deposits and petrography of calcrete crusts will allow to confirm (or discard) this hypothesis. Calcrete crusts were analyzed

Area		Measured Pipes	Top diameter (cm)	Depth (cm)	Diameter/Depth Ratio
All pipes					
Punta Funtanas	All free pipes	18	35	281	0.28
Roca Vecchia South	All pipes	27	75.7	45.4	4.88
Roca Vecchia North	All pipes	25	68.4	40.6	4.75
Roca Vecchia arch.	All pipes	20	65.8	45.3	1.44
Torre Specchiolla	All pipes	101	44	24.9	0.86
Torre Santa Sabina	All pipes	27	38.3	22.1	1.11
Mean			54.5	76.6	2.22
Only free pipes					
Punta Funtanas	All free pipes	18	35	281	0.28
Roca Vecchia South	Free pipes	6	65	170	0.34
Roca Vecchia North	Free pipes	4	77.5	172.5	0.59
Roca Vecchia arch	Free pipes	5	60	57	1.1
Torre Specchiolla	Free pipes	37	41.8	69.3	0.70
Mean			55.9	50.0	0.60

Table 1: Data on dissolution pipes of Punta Funtanas (Sardinia), Roca Vecchia, Torre Specchiolla and Torre Santa Sabina (Apulia)

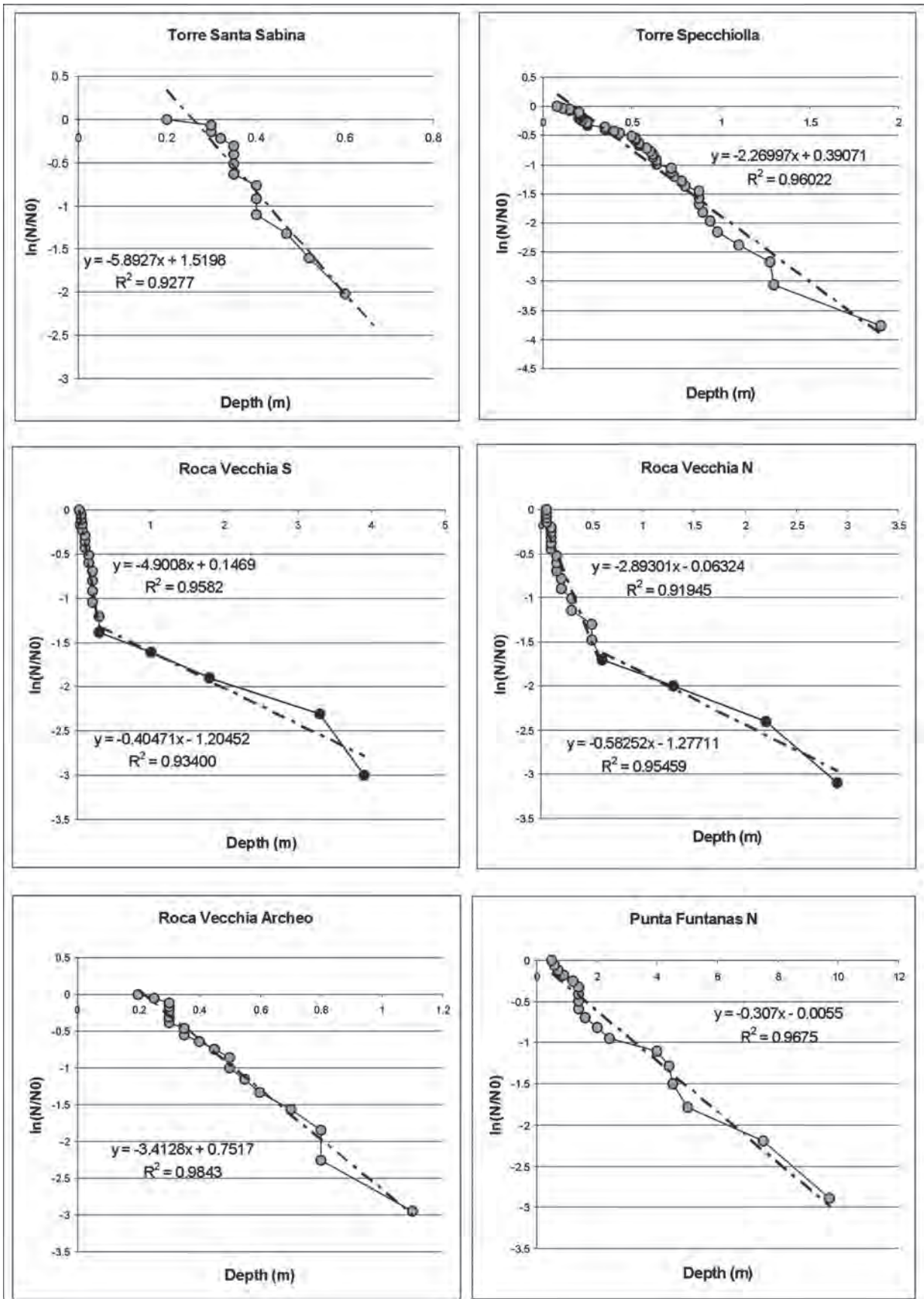

Figure 2: Semi logarithmical distribution of pipes against depth.

(on four samples) by Delle Rose and Parise (2003), and the preliminary results indicated likely formation of the crust in arid climate, with limited biological activity; however, no determination of the biogenic component was performed.

References

- Coetzee, F. (1975), Solution pipes in coastal aeolianites of Zululand and Moçambique. *Transactions of the Geological Society of South Africa*, **78**, 323–333.
- Blanc, A.C., and Cardini, L. (1961), Saggi nei pozzetti di erosione del “tufo” calcareo di Rocavecchia (Lecce). *Quaternaria*, 306–308.
- Day, A.E. (1928), Pipes in the coast sandstone of Syria. *Geological Magazine*, **65**, 412–415.
- Delle Rose, M., and Parise, M. (2003), Pozzetti carsici e processi geomorfologici a Rocavecchia (Prov. di Lecce). *Grotte e Dintorni*, **5**: 35–48.
- De Waele, J., Mucedda, M., and Montanaro, L. (2008), Morphology and origin of coastal karst landforms in Miocene and Quaternary carbonate rocks along the central western coast of Sardinia (Italy). *Geomorphology*, doi:10.1016/j.geomorph.2008.09.017
- Grimes, K.G. (2002), Syngenetic and eogenetic karst: an Australian viewpoint. In ed. Gabrovšek, F. *Evolution of karst: from prekarst to cessation: 407–414*. Karst Research Institute. Ljubljana-Postojna
- Harris, J.G., Mylroie, J.E., and Carew, J.L. (1995), Banana holes: unique karst features of the Bahamas. *Carbonates and Evaporites*, **10**: 215–224.
- Herwitz, S.R. (1993), Stemflow influences on the formation of solution pipes in Bermuda eolianite. *Geomorphology*, **6**: 253–271.
- Hoke, G.D., and Turcotte, D.L. (2002), Weathering and damage. *Journal of Geophysical Research*, **107**: 2210.
- James, N.P. (1972), Holocene and Pleistocene calcareous crust (caliche) profiles: criteria for subaerial exposure. *Journal of Sedimentary Petrology*, **42**: 817–836.
- Lauritzen, S.E. (2005), Karst as a weathering skin phenomenon: is there a simple, scale-independent model for karstification? *Proceedings of the 14th International Congress of Speleology, Athen-Kalamos, August 2005, Paper O-63*: 1–6.
- Livingston, W. (1944), Observations on the structure of Bermuda. *Geographical Journal*, **104**: 40–48.
- Lundberg, J., and Taggart, B.E. (1995), Dissolution pipes in Northern Puerto Rico: an exhumed paleokarst. *Carbonates and Evaporites*, **10**: 171–183.
- Marsico, A., Selleri, G.L., Mastronuzzi, G., Sansò, P., and Walsh, N. (2003), Cryptokarst: a case-study of the Quaternary landforms of southern Apulia (southern Italy). *Acta Carsologica*, **32**(2): 148–159.
- Milanovic, P. (1981), *Karst Hydrogeology*. New York, Water Resources Publications, 434 p.
- Spencer, T. (1981), Micro-topographic change on calcarenites, Grand Cayman Island, West Indies. *Earth Surface Processes and Landforms*, **6**: 85–94.
- Troester, J.W., White, E.L., and White, W.B. (1984), A comparison of sinkhole depth frequency distributions in temperate and tropic karst regions. *Proceedings 1st Multidisciplinary Conference on Sinkholes*, **1**: 65–73.
- West, I.M. (1973), Carbonate cementation of some Pleistocene temperate marine sediments. *Sedimentology*, **20**: 229–249.
- White, W.B. (1988), *Geomorphology and Hydrology of Karst Terrains*. New York, Oxford. University Press, 464 p.
- White, S. (1994), Speleogenesis in aeolian calcarenite: a case study in western Victoria. *Environmental Geology*, **23**: 248–255.

SPELEOGENESIS OF EXTENSIVE UNDERWATER CAVES ALONG THE GULF OF OROSEI (CENTRAL-EAST SARDINIA, ITALY)

JO DE WAELE¹, MARKUS SCHAFHEUTLE², THORSTEN WAELE³

¹Italian Institute of Speleology, University of Bologna, Via Zamboni 67 – 40127 Bologna, Italy, jo.dewaele@umibo.it

²Landesverein für Höhlenkunde, der Steiermark, HansFritzWeg 21e, A8043 Graz, Austria

³Protec Sardinia, Via Collodi 9 – 08022 Cala Gonone, Italy

The Gulf of Orosei (Central East Sardinia, Italy) is among the most important coastal karst areas of Italy and by far the most interesting for cave divers. Many important cave systems whose resurgences are often accessible for several kilometers have been explored in the area. The geomorphological observations made in the explored sections allow us to draw preliminary conclusions about their evolution. The development of these passages has clearly been influenced by a series of factors: (1) type (autigenic or allogenic) and amount of recharge; (2) hyperkarst in the salt-fresh water mixing zone; (3) Quaternary climate and sea level changes; (4) neotectonics and (5) Plio-Pleistocene volcanism.

1. Introduction

The Gulf of Orosei (central-east Sardinia, Italy) is a 37 km long vertical Jurassic limestone coast hosting many cave systems and submarine springs. Caves lacking fresh water outlets normally have limited underground development related to wave action along fractures. Extensive cave systems have developed instead where significant amounts of water are discharged into the sea. Recent cave diving research combined with geomorphologic investigation has enabled us to enhance the knowledge of the speleogenesis of these extensive underwater cave systems.

2. The main underwater caves

Coastal caves have been documented along the Gulf of Orosei over a long period of time (De Waele and Forti, 2002). The location of the most important of these cave systems is shown in Figure 1. These are, from north to south, *Bue Marino* cave, *Cala Luna* submarine spring, *Bel Torrente* cave, *Fico* cave and *Utopia-Ispuligidenie* cave system.

In *Bue Marino* Cave, at the end of its southern branch, a large underwater passage was explored in 1977 by Jochen Hasenmayer (Fancello and Mucedda, 1993). Major discoveries have been made mainly by Czech cave divers during the past 17 years (Hovorka, 1993; Hutňan et al., 2008) bringing the system to a total surveyed distance of over 17 km with several long underwater passages. The system is composed of three main branches: a southern one (*Ramo Sud*); a northern one (*Ramo Nord*), explored in 1990-1993; and an intermediate one (*Ramo Mezzo*), discovered only a few years ago. Most of these subterranean environments have large dimensions (mean diameter of 10 m) and are developed close to the present sea level, reaching their maximum depth in one of the sumps in *Ramo Nord*

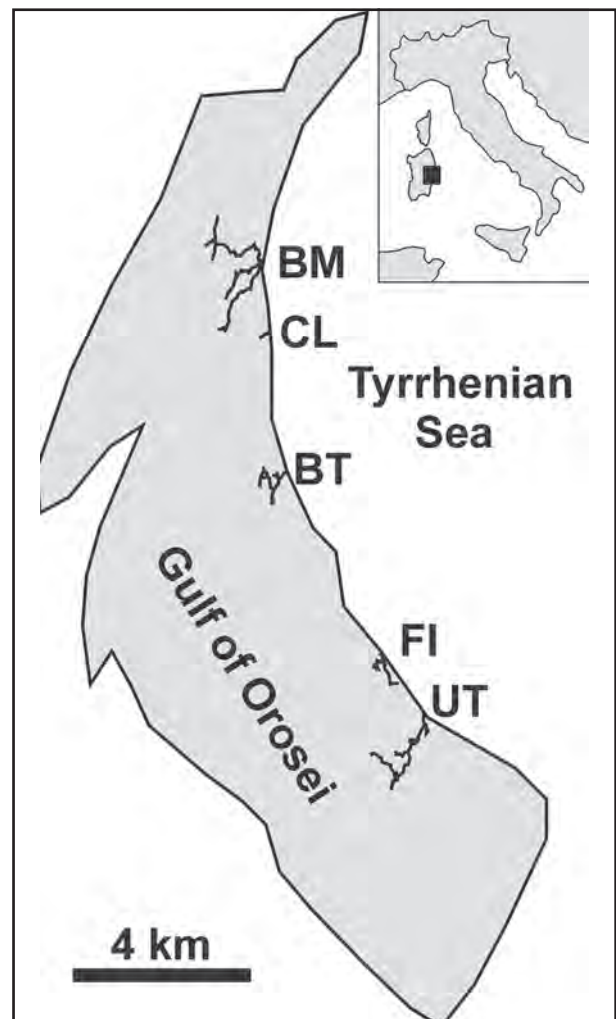

Figure 1: Gulf of Orosei (grey area) with the explored submarine caves (North upwards): BM: Bue Marino cave; CL: Cala Luna resurgence; BT: Bel Torrente cave; FI: Fico cave, and UT: Utopia system.

(-43 m). The largest conduit is the southern one that carries large amounts of fresh water originating in the *Codula Ilune* canyon during important floods, but it has a very low base flow (some l/s). Also the *Ramo Nord* is characterized by large conduits, draining water from the *Codula Fuili* recharge area. This branch has a base flow of 40 l/s, coming from four different subterranean springs (3 fresh water inlets and a brackish one) at 2 km linear distance from the present coastline, and discharges large amounts of fresh water (over a m³/s) during periods of significant flooding. The *Ramo Mezzo* is the least impressive in dimension and is probably linked to some smaller sinks in the *Codula Ilune* river bed. During base flow sea water penetrates 300 m into the southern branch where a flowstone dam inhibits further mixing, and 1500 m into the northern one. Mixing corrosion morphologies such as “Swiss cheese” are clearly visible at sea level in these parts. Close to the main sump of the *Ramo Sud* large conduits are filled with Plio-Pleistocene

basalts (Fig. 2A), demonstrating that karst development must predate the Quaternary Period (Mahler, 1979). Speleothems have been observed in the underwater passages up to a depth of -10 m.

The narrow and rectilinear resurgence of *Cala Luna* is located 100 m south of the famous beach and was explored in the late 1960s (Samoré, 1968). This spring, developed at an average depth of -10/-15 m and is the main discharge of the *Codula Ilune* cave system, the largest on Sardinia (Hovorka and Benisek, 1993; De Waele and Forti, 2002). In the past few years several promising new submerged passages have been discovered, bringing the total development to more than 1 km.

The *Bel Torrente* submarine spring, 500 m north of *Cala Sisine*, was discovered by Hasenmayer in the 70's (Morlock and Mahler, 1995), and explored first by an Italian team

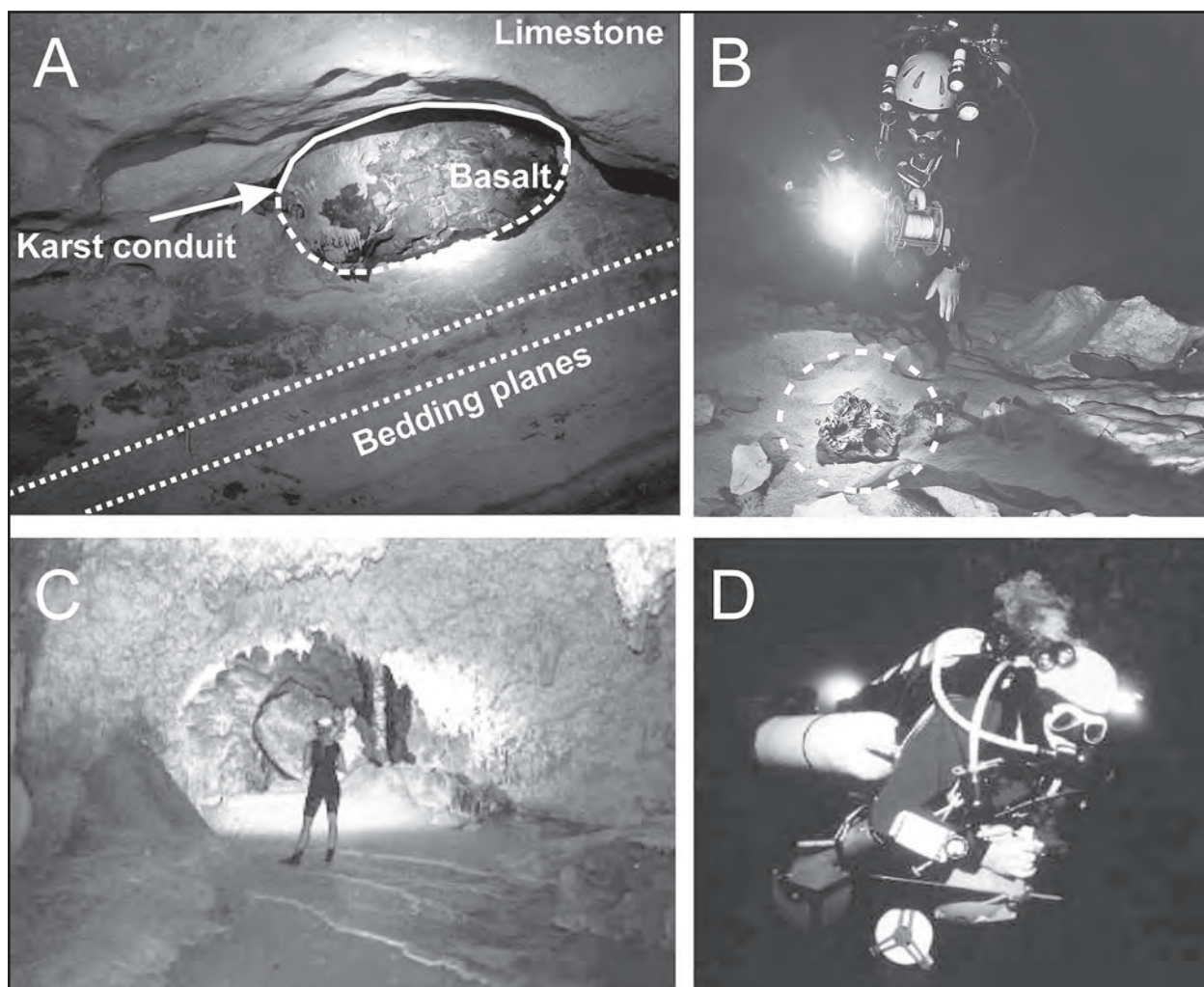

Figure 2: The caves: (A) Basalt (black) filling an ancient karst conduit in the southern branch of Bue Marino cave; (B) Monk seal skull (circled) in a submerged side branch of Bel Torrente cave, at -7 m water depth; (C) The fossil part of Fico cave; (D) Cave diver with complete equipment.

(Fancello et al., 2000), then later by Germans (Bohnert et al., 2005). At present the cave survey is over 3.5 km long, but at least another 500 m of passages have already been explored by Rick Stanton and Thorsten Waelde in 2008. The new passages keep going further inside the mountain. The main conduit is a huge passage, over 10 m in diameter, continuing close to sea level for 600 m, then plunging to depths exceeding 50 m. In side passages various skeletons of Monk seals have been discovered (De Waele et al., 2009) (Figure 2B). The cave also has well-decorated passages above sea level, and speleothems have been found at up to -10 m of water depth. A clear halocline is visible for the first 300 m (varying with hydrological conditions), with 1-2 m of fresh water floating on a salty layer. Deeper into the system entire passages are filled with fresh water. Average base flow rate is estimated to be 100 l/s, reaching several m³/s after heavy rains (Morlock and Mahler, 1995).

The Fico Cave is located about 4 km south of *Cala Sisine*, at an elevation of 15 m asl. Its air-filled passages were explored in the late 1960s (Donini and Monaco, 1968) (Figure 2C). Recent cave diving has allowed the discovery of several underwater passages, bringing the total development to more than 2.5 km. The fossil conduits develop between 5 and 15 m asl while all underwater tunnels stay close to sea level.

The *Utopia-Ispuligidenie* cave system is located one more kilometer to the south. The corresponding outlet of the *Bacu Mudaloro* canyon was discovered by Jochen Hasenmayer (Jantschke, 1998). This impressive submarine cave system, with extremely well developed and wide cave tunnels (10-15 m width on average), explored

and surveyed by Germans since 1996, reaches a total length of more than 6.5 km (Schafheutle et al., 2001). Its main passage develops at an average water depth of -30 m and reaches the deepest point at 1.5 km linear distance from the coast (surveyed depth of -102 m with no floor visible). The floor is estimated to be at a depth of -120 m). These extreme conditions force explorers to use rebreather diving techniques (Fig. 2D). Fresh water has been observed up to a depth of -15 m during the summer expeditions, but the lack of sediments on the floor of the submerged tunnels is evidence that winter floods must completely fill these huge conduits. The discharge of this system is presently at the *Ispuligidenie* resurgence, some 200 m to the south. Speleothems have been observed up to -30 m water depth. Utopia is at present the longest underwater cave in Italy and the deepest on Sardinia.

3. Speleogenesis

Coastal carbonate areas are characterized by unique karst features that are related to their vicinity to the marine environment (Mylroie and Carew, 2000). In this area, in fact, the mixing of salt and fresh water causes enhanced dissolution that, combined with other biological and physical processes, lead to typical landforms (tidal notches, enlarged cave entrances, etc.) (Forti, 1993). The altitudinal development of caves is mainly controlled by the position of the water table (Palmer, 1987), which, in the area close to the coast, roughly corresponds to sea level. Sea level changes, especially those of the last 125,000 years, have had an important influence on the shape and position of these caves. Cave levels, especially in combination with notches, can thus be used to reconstruct the past position of sea level (Florea et al., 2007). Caves and notches are

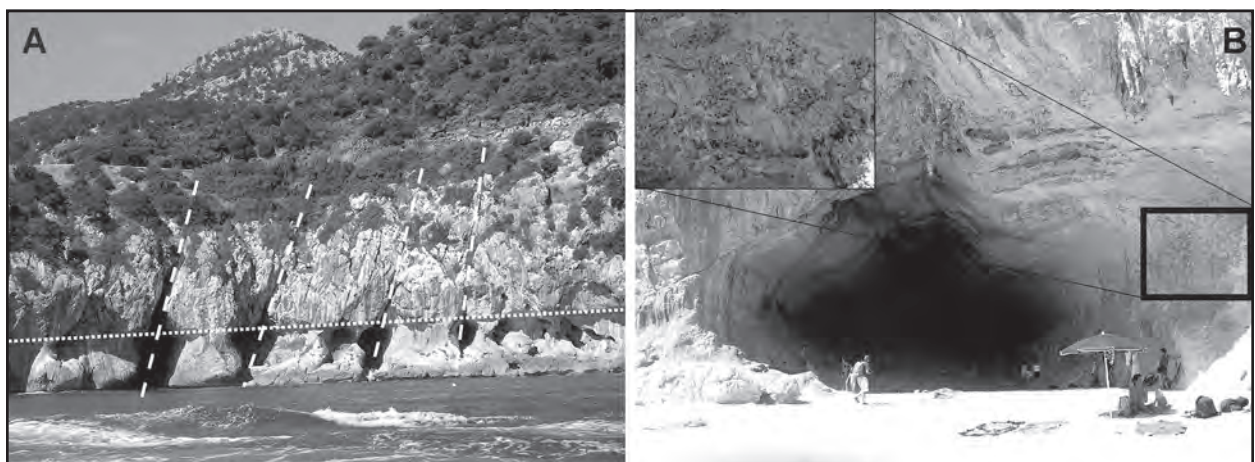

Figure 3: Influence of sea level and fractures on cave development: (A) Coastal caves South of Cala Fuili, with Tyrrhenian notch at 10 m asl. (dotted line) and enlargement of fractures (hidden vertical lines) mainly by mechanical erosion; (B) Cala Luna cave with tidal notch at 9 m asl., two fractures guiding the coastal cavern development. Inset shows Lithophagae holes enhancing notch formation.

mainly clustered around depths of 10 m below to heights of 10.5 m above sea level (Carobene, 1978; Carobene and Pasini, 1982; Antonioli et al., 1999). The highest notch, ascribed to the Tyrrhenian stage (MIS 5e, 125,000 years B.P.) (Fig. 3A and B) (Antonioli and Ferranti, 1992) has a decreasing elevation from north to south between 10.5 and 7.7 m asl and its lateral continuity indicates a relative tectonic stability since, with an exception given for the slight N-S tilting. The notch at -10 m formed during a period of sea level stability and occurred between MIS 5e and MIS 2 (125,000-20,000 years B.P.), corresponding also to a well-recognizable base level since most of the coastal caves are developed at or slightly above this water depth. A sea level still-stand documented at a depth of -45 to -50 m and aeolian sand deposits outcropping on the continental shelf up to -120 m are attributed to the same period (MIS 5e-2), and are probably characterized by climatic pulses with frequent arid intervals.

Another important speleogenetic factor is the type of recharge: where fresh water slowly seeps from a wide range of poorly enlarged fissures, a flank margin cave forms; where large amounts of fresh water exit from a single well-enlarged fracture, a large underwater cave system develops (Fig. 4). This system will have continental characteristics in its upstream sections (with an up-and-down profile) and will develop in the mixing zone in its coastal sections (sub horizontal) (Myrloie and Carew, 1995). The presence of fresh water inside the major coastal caves surely resulted from the widening of the joints at the entrance by hyperkarst processes due to mixing (Back et al., 1986). The great conduit dimensions can be explained by large variations in discharge and oscillations of the freshwater-saltwater boundary due to both sea level and climate changes. Base flow during most of the year is relatively low, but complete flooding of the conduits currently takes place once each year on average. Flooding induces erosion in the conduits from interaction with solid load. The climate was much wetter during the first half of the Holocene in the western Mediterranean, thus suggesting faster cave development before 6,000 y B.P. (Magny et al., 2002). Around that time the Tyrrhenian sea level was between -6 and -10 m below present (Antonioli et al., 2004) as fossil Monk seal bones in *Bel Torrente* Cave indicate (De Waele et al., 2009).

Basalts of Plio-Pleistocene age filling fully-developed conduits in the *Bue Marino* Cave show that cave systems inland were already present before the Pliocene, but the main passage, developing close to present sea level, has cut these ancient phreatics and appears therefore to be much

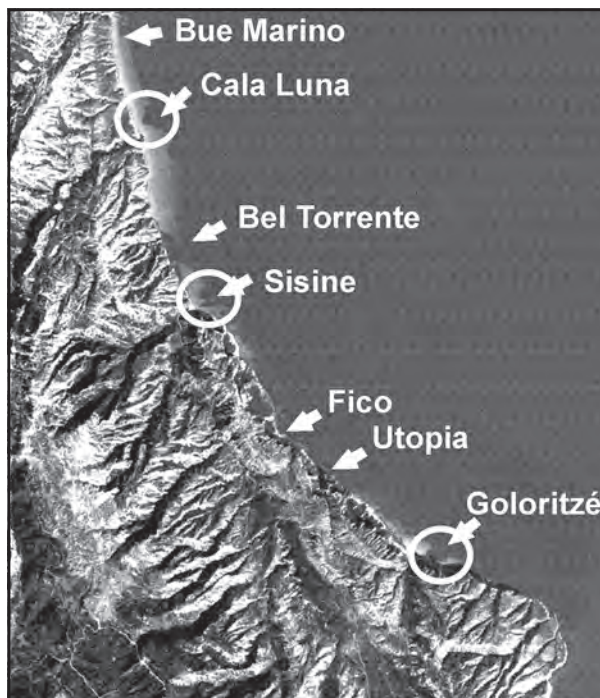

Figure 4: Landsat TMS image, band 1 (December 23, 1998) with the major cave systems indicated. The circled areas correspond to sea water transparency indicating fresh water outflows.

younger. All of the underwater caves in the Gulf of Orosei have presumably formed since MIS 5e. The oldest caves are the fossil sections of *Fico*, *Bel Torrente* and *Bue Marino* caves, which probably formed during the Tyrrhenian high stand while *Utopia* appears to have developed later during the sea level still stand at -45 — -50 m. The N-S tilting, revealed by the inclined Tyrrhenian notch, could be responsible for the southward translation of discharge points both from *Bue Marino* to *Cala Luna* (Forti and Rossi, 1991) and from *Utopia* to *Ispuligidenie* springs.

4. Conclusions

Cave diving exploration in the Gulf of Orosei has allowed documentation of several extensive underwater caves for a total development of more than 30 km. Besides the *Bue Marino* Cave and the *Cala Luna* resurgence, explored by Czech divers, great discoveries have been made mainly by Germans in *Bel Torrente* Cave, *Fico* Cave and the extensive *Utopia-Ispuligidenie* underwater system.

The morphology and the evolution of these underwater caves is influenced by a series of factors: (1) type (autigenic or allogenic) and amount of recharge; (2) hyperkarst in the saltwater-freshwater mixing zone; (3) Quaternary climate and sea level changes; (4) neotectonics; (5) Plio-Pleistocene volcanism.

Acknowledgements

The authors would like to thank the many cave divers who explored and surveyed the underwater caves, especially Jürgen Bohnert, Salvatore Busche, Peter de Coster, Herbert Jantschke, Karsten Gessert, Andreas Kücha, Michael Kühn, Anke Örtel, Enrico Seddone, Luca Sgualdini, and Rick Stanton. The photographs of Figure 2B have been kindly provided by Enrico Seddone, those of Figure 2 C and D by Andreas Kücha.

References

- Antonioli, F., and L. Ferranti (1992), Geomorfologia costiera e subacquea e considerazioni paleoclimatiche sul settore compreso tra S. Maria Navarrese e Punta Goloritzé (Golfo di Orosei, Sardegna). *Giornale di Geologia*, **54** (2), 66–89.
- Antonioli, F., Silenzi, S., Vittori, E., and Villani, C. (1999), Sea level changes and tectonic mobility: precise measurements in three coastlines of Italy considered stable during the last 125 ky. *Physics and Chemistry of the Earth* (A), **24** (4), 337–342.
- Antonioli, F., E. Bard, E.K. Potter, S. Silenzi, and S. Improta (2004), 215-ka history of sea-level oscillations from marine and continental layers in Argentarola cave speleothems (Italy). *Global and Planetary Change*, **43** (1–2), 57–78.
- Back, W., Hanshaw, B.B., Herman, J.S., and Van Driel, J.N. (1986), Differential dissolution of a Pleistocene reef in the ground-water mixing zone of coastal Yucatan, Mexico. *Geology*, **14**, 137–140.
- Bohnert, J., Jantschke, H., and Oertel, A. (2005), Novità dalla grotta del Bel Torrente. *Sardegna Speleologica*, **22**, 7–11.
- Carobene, L. (1978) - Valutazione di movimenti recenti mediante ricerche morfologiche su falesie e grotte marine del Golfo di Orosei. Memorie della Società Geologica Italiana, **19**, 641–649.
- Carobene, L., and Pasini, G.C. (1982), Contributo alla conoscenza del Pleistocene superiore e dell'Olocene del Golfo di Orosei (Sardegna orientale). *Bollettino della Società Adriatica di Scienze*, **64**, 5–35.
- De Waele, J. (2004), Geomorphologic evolution of a coastal karst: the Gulf of Orosei (Central-East Sardinia, Italy). *Acta Carsologica*, **33** (2), 37–54.
- De Waele, J., and Forti P. (2002), Estuari sotterranei. *Grotte Marine: cinquant'anni di ricerca in Italia*, Cicogna, F., Nike Bianchi, C., Ferrari, G., and Forti, P. (Eds.), Ministero dell'Ambiente e della Tutela del Territorio, Rapallo, p. 91–104.
- De Waele, J., Brook, G.A., and Oertel, A. (2009), Monk Seal (*Monachus Monachus*) bones in Bel Torrente cave (Central-East Sardinia) and their paleogeographical significance. *Journal of Cave and Karst Studies*, **71**(1), in print.
- Donini, L., and Monaco, C.A. (1968), “La grotta del Fico” e le sue concrezioni eccentriche. *Speleologia Emiliana*, **3** (1–2), 45–60
- Fancello, L., Fileccia, A., and Mazzoli, M. (2000), La Grotta del Bel Torrente. *Speleologia*, **43**, 67–69.
- Fancello, L., and Mucedda, M. (1993), Esplorazioni speleosubacquee alla Grotta del Bue Marino di Dorgali (anno 1993). *Sardegna Speleologica*, **4**, 31–40.
- Florea, L.J., Vacher, H.L., Donahue, B., and Naar, D. (2007), Quaternary cave levels in peninsular Florida. *Quaternary Science Reviews*, **26**, 1344–1361.
- Forti, P. (1993) - Meccanismi genetici ed evolutivi delle grotte marine. *Speleologia* **28**, 63–67.
- Forti, P., and Rossi, G. (1991), Idrogeologia ed evoluzione carsica della Codula di Luna (Sardegna). *Atti e Memorie della Commissione “E. Boegan”*, **30**, 53–79.
- Hovorka, J. (1993), Cave diving exploration on Sardegna. *Czech Speleological Society*, **30**, 30–36.
- Hovorka, J., and Benisek, L. (1991), Sardegna '90-Grotta del Bue Marino. *Speleofòrum*, **10**, 8–10.
- Hutňan, d., Čermák, J.J., and Hovorka, J. (2008), Grotta del Bue Marino 2007 – velké plány, velké objevy. *Speleofòrum*, **27**, 94–98.
- Jantschke, H. (1998), Grotte subacquee lungo la costa di Baunei. *Sardegna Speleologica*, **14**, 28–38.
- Magny, M., Miramont, C., and Sivan, O. (2002), Assessment of the impact of climate and anthropogenic

- factors on Holocene Mediterranean vegetation in Europe on the basis of palaeohydrological records. *Palaeogeography Palaeoclimatology Palaeoecology*, **186**, 47–59.
- Mahler, A. (1979), Verkarstung der Karbonatgebiete am Golfo di Orosei (Sardinien). *Geologischer Palaeontologischer Mitteilungen Innsbruck*, **7** (8–9), 1–49.
- Morlock, W., and Mahler, A. (1995), La Grotta del Bel Torrente: la più importante risorgenza carsica del complesso calcareo del Golfo di Orosei. *Sardegna Speleologica*, **8**, 35–36.
- Mylroie, J.E., and Carew, J.L. (1995), Karst development on carbonate islands. Chap. 3 in *Unconformities and porosity in carbonate strata*, Budd, D. A., Saller, A.H., and Harris, P.M. (Eds.), American Association of Petroleum Geologists Memoir, **63**, 55–76.
- Mylroie, J.E., and Carew, J.L. (2000), Speleogenesis in coastal and oceanic settings. *Speleogenesis and Evolution of Karst Aquifers*, Klimchouk, A.B., Ford, D.C., Palmer, A.N., and Dreybrodt, W. (Eds.), National Speleological Society, Huntsville, p. 226–233.
- Palmer, a.n. (1987), Cave levels and their interpretation. *National Speleological Society Bulletin*, **49**, 50–66.
- Samoré, T. (1968), Esplorazioni subacquee in Sardegna. *Rassegna Speleologica Italiana*, **20** (3–4), 254–255.
- Schafheutle, M., Jantschke, H., Lawo, Ph., Kühn, M., and Kücha, A. (2001), Speleological Survey of the Baunei Coast and the Utopia Cave. *Atti del Convegno di Studio Il Carsismo e la Ricerca Speleologica in Sardegna*, De Waele, J. (Ed.), Cagliari, p. 219–226.

MECHANISM OF SALT CONTAMINATION OF KARSTIC SPRINGS RELATED TO THE MESSINIAN DEEP STAGE: THE SPELEOLOGICAL MODEL OF PORT MIOU (FRANCE)

ERIC GILLI¹ and THOMAS CAVALERA²

¹University Paris 8 and UMR Espace 6012 Nice.

²University of Provence

Submarine karst springs are common on the Mediterranean shore but most of them are brackish, which limits their usefulness. Various experiments to limit freshwater/seawater mixing were attempted in the past but have failed. This study examined Port Miou (Cassis, France) showing that salinity is present at 2300 m from the entrance and at a depth of 179 m bsl. The geometry of this setting is inherited from a complex palaeogeography. The lowering of the Mediterranean during the Messinian salinity crisis has made possible the existence of caves several hundred meters below present sea level. The presence of titanium in the sediment of the cave seems to be a residual product of an alumina factory that is discharged at a depth of 300 m, 6 km south of the cave. This supports the hypothesis of a deep aspiration of seawater by a Messinian gallery. A similar example exists in Kefalonia Island, where a marine intrusion is observed in coastal sinkholes.

1. Introduction

Submarine karst springs are common on the Mediterranean shore but most of them are brackish, which limits their usefulness. For the southeast coastline of France, these aquifers are estimated at 10 m³/s. For the entire Mediterranean basin, the potential is approximately 1000 m³/s which theoretically supports the domestic needs of 350 million persons. Numerous attempts to catch these springs (dams, flexible or rigid artificial insulations, pumping, etc.) ended in failure (Gilli, 2003). The principle was generally to artificially augment the hydraulic gradient in order to lower the contact between fresh water and sea water. Recent explorations of deep submarine caves explain why these attempts failed.

Cave divers or ROV have reached important depths in several places: 308 m (224 m b.s.l.) in the Fontaine de Vaucluse (France) and 179 m (179 m bsl) in the Port Miou spring (France). Similar examples exist also in Greece, Italy, Spain and Turkey. These depths are more important than the lowering of the water table related to the Quaternary glacio-eustatism (120 m bsl) and several authors imagine a possible settlement of the karstic systems during the Messinian stage [-5.95 to -5.35 Ma] when a large drop in sea-level, down to 1,500 m, occurred in the Mediterranean Sea (Ryan et al, 1973; Gautier et al, 1994; Krijgsman et al, 1999). It caused the sedimentation of important evaporitic levels on the bottom of the sea, and the production of deep submarine canyons on the margins of the basin. Deep canyons were also formed inland that are now filled with alluvium. This drastic

drop in base level affected the local karst systems and caused the deepening of the water circulation and the possible reopening of palaeokarsts. Several authors pointed out the influence of the Messinian event on the French karst (Julian and Nicod, 1984; Audra et al, 2004) and it has been widely recognized in Italy (Bini, 1994), in Greece (Arfib, 2001) and in Spain (Fleury, 2005). Recent works on karstic springs suggest the possibility of a deep salt contamination of the main Mediterranean brackish springs, due to the presence of deep karstic galleries related to that Messinian model (Gilli, 2001). The current study of the shoreline aquifers of southeastern France has enabled us to propose an operating model.

2. The Port Miou System

In Cassis (South-eastern France) the springs of Port-Miou and Bestouan are the outlets of an important system of submarine karstic galleries explored since ~1950 (Table 1). The average discharge is between 2 to 5 m³s⁻¹ but the water is brackish and cannot be used for water supply. The Port Miou cave is a 2.4 kilometers long gallery that extends in the limestone series of Calanques. The total length of Bestouan is 3.7 kilometers. Dye tests and monitoring have proved the relation between the two caves but no connecting passage has been discovered. At Port Miou a dam was built in the 70's inside the cave, to prevent the marine intrusion, but in spite of a noticeable decrease of the salinity down to 3 gL⁻¹, it had not been possible to obtain drinkable fresh water upstream of the dam (Potié, 1974) (Fig. 1). The use of helium and later rebreathers by cave divers made possible

1953	1st true exploration in the Port Miou cave by the EOLE team (J. Blanc, J. Picard, et M. Galerne)
1955-1956	Exploration and study of submarine galleries by O.F.R.S. (Cdt Cousteau) : the team reach 280 m in Port Miou and 40 m in Bestouan. Topographic, thermographic and faunistic data is collected (CORROY et al, 1958)
1960	A US scientific diver (C. Limbaugh) get lost and die during a photography session in Port Miou
1964-1966	Divers of G.E.P.S. (Claude Touloumdjian) reach 400 m in Port Miou et 450 in the Bestouan.
1968	Discovery in Port Miou of an aerial zone at 530 m from the entrance et exploration of the gallery up to 870 m.
1968-1973	Study and construction of an underground dam by the SRPM. (POTIÉ,1974)
1978	C. Touloumdjian reaches 1365 m in Port Miou and Francis Leguen 1400 m in Bestouan
1981	Discovery in Port Miou of a vertical shaft at 2230 m from the entrance by B.Léger. The terminal depth is -82 m bsl
1982	Two Italian and Swiss divers get lost and die in Port Miou.
1980-1983	The divers C. Touloumdjian and F. Leguen reach 2290 m in Bestouan
1990-1993	Series of explorations by C.R.P.S. (Comité Régional de Plongée Souterraine) during which the divers reach 3000 m in Bestouan. In Port Miou M.Douchet goes down to -147 m bsl (DOUCHET,1993).
2001	Starting of new geological studies (GILLI, 2001)
2005	J Meynié, using rebreather, reaches -172 m bsl in Port Miou.
2008	X. Meniscu, using rebreather, reaches -179 bsl in Port Miou

Table 1: History of explorations and studies in Port Miou and Bestouan (Cassis, France)

the exploration of a vertical pit, down to 179 m below sea level, at the end of the cave. At that depth, the water is still brackish.

Discharge, temperature and salinity of the spring had been collected for several months in the 70's, the discharge varied from 2 m³s⁻¹ to 100 m³s⁻¹ and the salinity was from 20 gL⁻¹ during low water to 0 gL⁻¹ during floods. New data have been recorded since December 2004 with an average discharge of 3 m³s⁻¹ and salinity between 14 and 3.4 gL⁻¹. The average values indicate a medium flow of seawater close to 1 m³s⁻¹ but the mechanism of the contamination is still unknown. Two hypotheses are possible that offer two different

possibilities to reduce the salinity:

- (i) a classical hypothesis where the fresh water circulates in a deep karstic gallery connected to a matrixial fissured zone polluted by sea water. The diminution of the salinity is possible by augmenting the pressure of fresh water in the conduit (Arfib, 2001). In Port Miou the study of the discharge/salinity graphs did not make it possible to see such a mechanism (Arfib et al, 2006 ; Cavalera, 2007).
- (ii) a speleological hypothesis where the fresh water circulates in a deep karstic gallery connected to the sea by another gallery (Gilli et al, 2004). This suggests that the

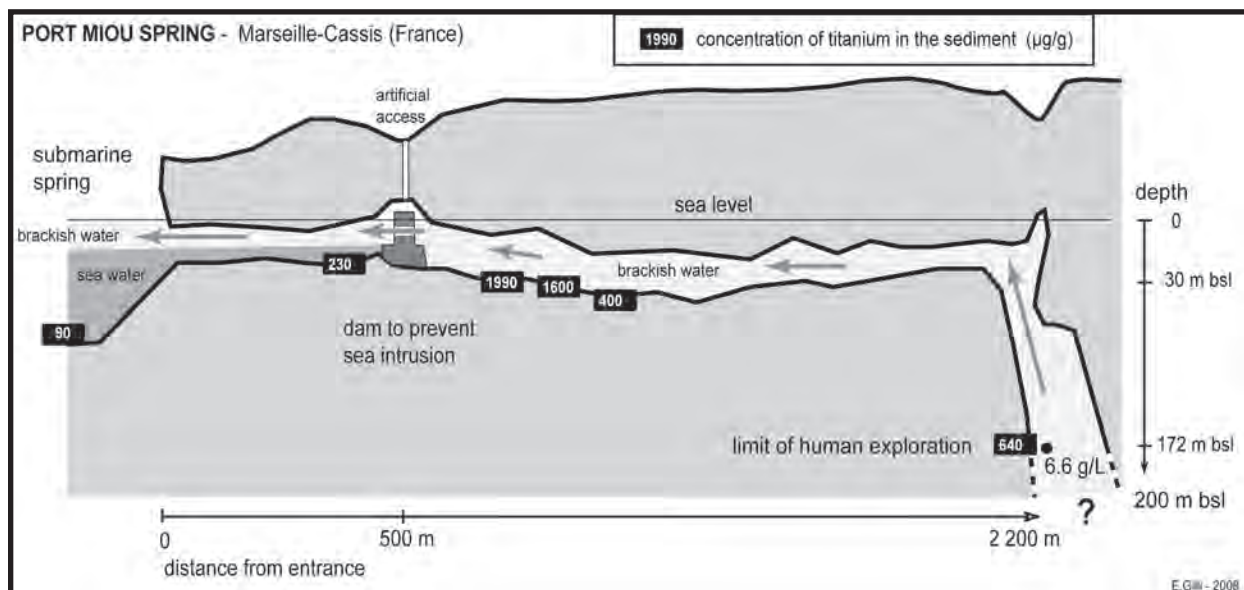

Figure 1: Cross section of the Port Miou gallery.

matrix permeability of the limestone is low.

In the area of Port Miou, this second hypothesis is supported by the existence of karst features below current sea level. The bathymetric map of Lion gulf (Berne et al, 2002) and a morpho-bathymetric study (Collina-Girard, 1996) reveal the existence of a limestone plateau that extends a few kilometers south to the Calanques, with dolines at a depth of 150 m below present sea level. A deep submarine valley, the canyon of Cassidaigne, whose bottom is at a depth of 1000 m, cuts this plateau. This canyon looks like a karst pocket valley and is not connected to a continental valley. Several dives with small submarines have revealed on the walls the existence of caves with speleothems (oral communication from COMEX). We assume that, during the Messinian deep stage, the underground river of Port-Miou was flowing 200 or 300 hundred meters below its current position and has excavated the canyon of Cassidaigne. At the end of the Messinian deep stage, the system was breached by the sea, causing the fresh water to flow through an upper gallery. Now the presence of a deep paleo-drain, filled by seawater, could provoke a saltwater intrusion into the karst system.

3. Three Pipes Model

A three pipes model can be used to understand the

mechanism in static conditions (Drogue,1993) (Fig.2, left panel). At equilibrium:

$$(H+\Delta H_1)\rho_1 = (H+\Delta H_2)\rho_2 = (H+\Delta H_3)\rho_3$$

With H depth of mixing zone, ΔH_1 karst hydraulic gradient, ρ_1 density of fresh water,

ΔH_2 altitude of brackish spring, ρ_2 density of brackish water,

ΔH_3 variation of sea level, ρ_3 density of sea water.

We have developed a laboratory model of the system, with 3 pipes respectively filled with colored sea water, fresh water and brackish water (Fig. 2-right). It perfectly simulates the mechanism. When fresh water is injected in the fresh water pipe (ΔH_1 augments), a current moves towards the brackish outlet where the density is lower than in the sea pipe, ρ_2 decreases by dilution and this creates a dilution and an aspiration (negative ΔH_3) in the seawater pipe.

In Port Miou, the presence of an anthropic tracer supports this affirmation. In the area of Gardanne a factory of alumina generates important quantities of residual products locally called "red mud". The red mud contains an

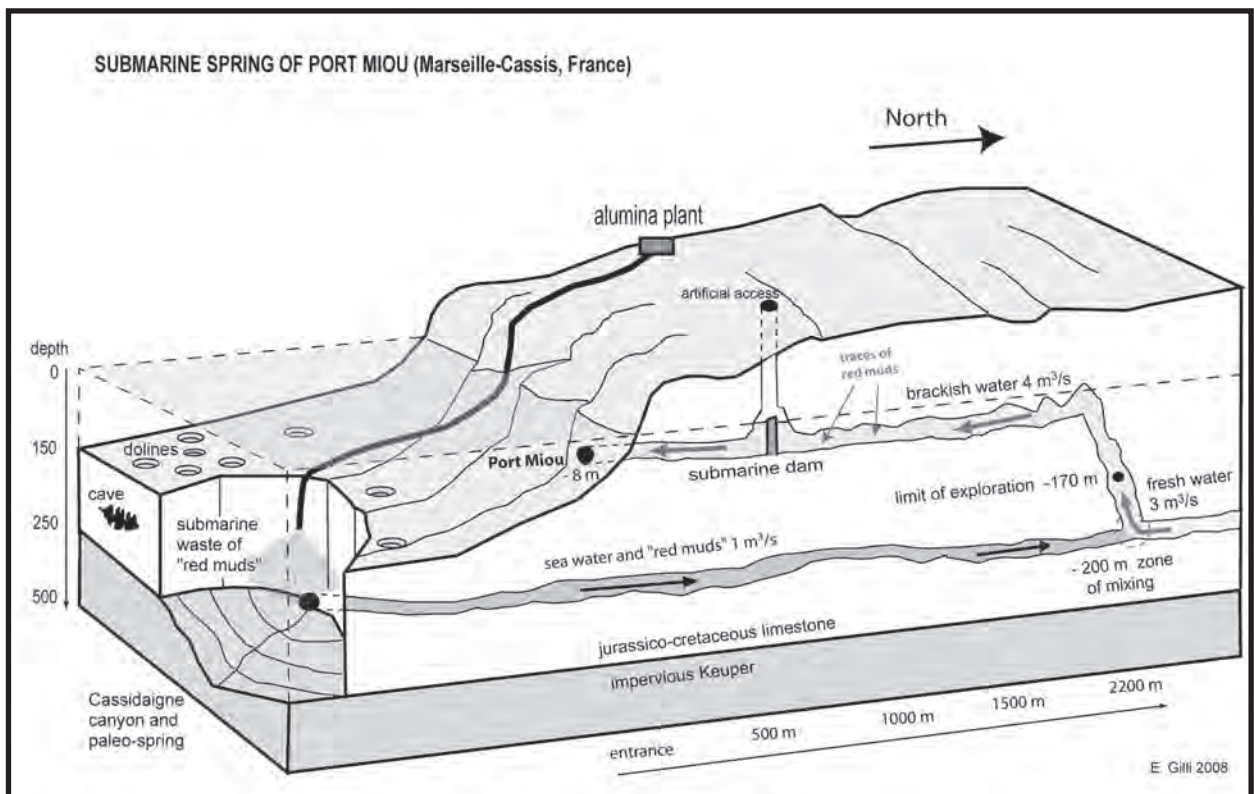

Figure 2: Three pipes model.

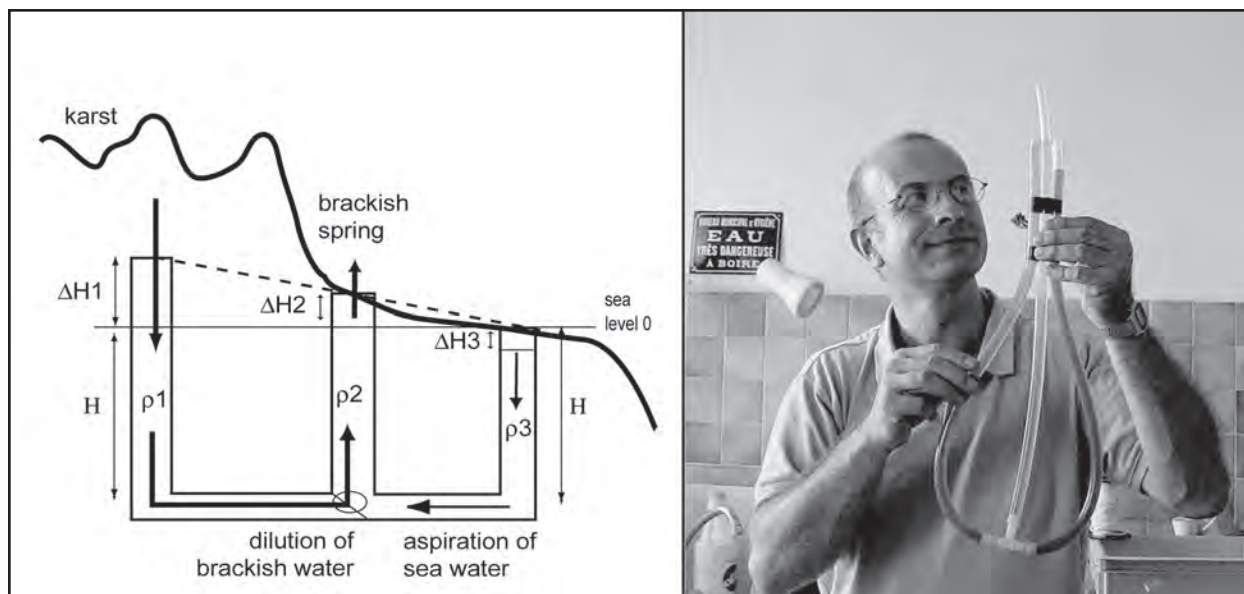

Figure 3: The speleological model of Port Miou (Cassis, France).

important quantity of heavy metals notably titanium and chromium. This mud is mixed with water and is transported since ~1970 by a submarine pipe towards the canyon of Cassidaigne where it is discharged into the sea, at a depth of 300 m (Fig. 3).

Several samples of sediments (surface and core samples) were collected in the Port Miou gallery upstream and

downstream of the dam. Most of samples upstream the dam present a thin level of red mud laying on a thick level of gray to brown marine silt. The upper layer contains a much more important quantity of titanium than samples collected in this area (Table 2). When analyzing the cave sediment a few centimeters below its surface the concentration of titanium is much lower. Downstream of the dam the concentration is also lower. This shows that red particles, rich in titanium,

Sample	Cr	Cu	Ti	V	Fe	Mn	Ni	Pb	Zn
“Red muds” (in factory)	1815	23,4	32 415	717	184 500	351	n.d.	94,5	38,3
Marine sediment with red muds in Cassidaigne canyon	64	31.5	168	37,4	26 003	1113	n.d.	25,4	81
PM100705 surface sediment of Port Miou gallery	36.6	12,9	1992	71,3	21 101	888,65	36,3	22,6	197,2
PM100705_1 surface sediment of Port Miou gallery			1600						
PM 191105_1 surface sediment of Port Miou gallery			400						
PM 191105_2 surface sediment of Port Miou gallery			640						
PM160405 sediment of Port Miou: 10 cm depth			0.48						
PM160405 sediment of Port Miou: 40 cm depth			0.26						
PM160405 sediment of Port Miou: 80 cm depth			0.22						
BE140606 sediment of Bestouan gallery: surface	40	n.d.	680	0,07	27	1500	40	20	160
BE140606 sediment of Bestouan: 5 cm depth			360						
BE140606 sediment of Bestouan: 15 cm depth			260						
BE140606 sediment of Bestouan: 30 cm depth			220						
BE140606 sediment of Bestouan: 38 cm depth			430						
Continental karstic sediment (terra rosa)			610						
Roucas Blanc (sediment of a brackish karstic spring)	<10	<10	20	10	1100	-	-	<10	-
Continental waste of La Barasse (ground)	490	20	17	0,6	275 000	-	-	370	-
Continental waste of La Barasse (leachate)	60	30	1,1	0,13	38 000	-	-	60	-

Table 2: Concentration of heavy metals in Port Miou and the area of Cassis (France).

have been recently transported by a current of brackish water from the bottom of the cave to the entrance. This supports an aspiration of sea water with particles of red mud by a deep gallery connected to the canyon of Cassidaigne. Other possible explanations have been unsuccessfully studied. The factory, where the alumina is processed, is on an impervious substratum. The inland wastes have low concentration of titanium. There are no leaks in the pipeline. Environmental studies (Arnoux and Stora, 2003) show that the red mud, discharged in the canyon, remains at an important depth and is never present close to the spring on the continental platform. One explanation could be an underground sea current in a karstic conduit that transports the particles of red mud towards the north. New analysis is underway to confirm it.

4. The Argostoli System

Examples of marine aspiration are already known in Mediterranean sea at Argostoli (Drogue, 1989, 1993 ; Maurin and Zötl, 1965) and Bali (Greece) (Arfib, 2001) or Moraig-Toix (Spain) (Cortes et al, 2000). Near the small city of Argostoli, on the western coast of Kefalonia island, a sea intrusion is observed in coastal sinkholes. The flow rate of the seawater is sufficient to power mills (Fig.4). A dye test conducted in 1963 showed a communication, after 16 days, with the brackish springs of Sami on the eastern coast of the



Figure 4: Argostoli mill in Kefalonia (Greece).

island (Maurin and Zötl, 1965). In the sinkholes, the level of the seawater sumps is 1 m bsl. In the Sami springs it is 1 m asl.

5. Conclusion

This speleological model can probably be extended to other karstic springs in the Mediterranean Sea. It opens two main directions for the catchment of water: drilling inland, far enough from the coast, to reach the aquifer upstream of the mixing with sea water, or obstructing the deep gallery

to prevent the seawater intrusion. A comparison with the Floridian karst, where geothermal conditions are evoked (Kohout et al, 1977) to explain the presence of deep karstic galleries should be very interesting to do.

Acknowledgements

This study was realized with the help of the Conservatoire du littoral (Mr Estève), the ONF (Mr Vincent), the Société des Eaux de Marseille (MM. D'Aspe, Onatsky and Lieutaud), the Alcan-Rio Tinto society (Mrs Raignault), the Camargo foundation (Mr Dautricourt). Monitoring and sampling was done by the divers: C. Touloumdjian, M. Douchet, J. Meynié, F. Tessier and by our colleagues B. Arfib, D. Chevaldonné.

References

- Arfib, B. (2001) Etude des circulation d'eaux souterraines en aquifère karstique côtier: observations et modélisation de la source saumâtre Almyros d'Héraklion, Crète (Grèce). Thèse de troisième cycle, Université Paris VI, p. 337.
- Arfib, B., Cavalera, T. and Gilli, E., (2006) Influence de l'hydrodynamique sur l'intrusion saline en aquifère karstique côtier. *Comptes Rendus Geoscience*, **338**, 757–767.
- Arnoux, A. & Stora, G. (2003) Analyses granulométriques et chimiques des sédiments prélevés dans la zone de rejet des boues résiduelles de l'industrie de l'aluminium (Campagne ALPECAST 2 sept-oct 2002), Comité de suivi scientifique résidus de Bauxite Aluminium Péchiney.
- Audra P., Mocochain L., Camus H., Gilli, E. and Clauzon, G. (2004) The effect of the Messinian Deep Stage on karst development around the Mediterranean Sea. Examples from Southern France. *Geodinamica Acta*, **17**(6), 27–38.
- Berné, S., Et Al., (2002) Cartes morpho-bathymétriques du Golfe du Lion au 1/100000, IFREMER, Région Languedoc-Roussillon.
- Bini, A., (1994) Rapports entre la karstification périméditerranéenne et la crise de salinité messinienne, l'exemple du karst lombard (Italie). *Karstologia* **23**, 33–53.
- Breznik, M., (1998) Storage Reservoirs and Deep Wells in Karst Regions. Balkema, Rotterdam, Brookfield, p.

- 251.
- Calvino, F. & Stefanon, A., (1969) The submarine springs of fresh water and the problem of their capture, Rapp. Comm. Int. Mer Médit.
- Cavalera, T., (2007) Etude du fonctionnement et du bassin d'alimentation de la source sous-marine de Port Miou (Cassis, Bouches-du-Rhône). Approche multicritère. Mémoire de thèse, Marseille, 397 pp.
- Collina-Girard, J. (1996) Préhistoire et karst littoral: la grotte Cosquer et les calanques marseillaises, *Karstologia*, **27**, 27–40.
- Corroy, G., Gouvernet, C., Chouteau, J., Sivirine, A., Gilet, R. and Picard, J. (1958) Les résurgences sous-marines de la région de Cassis - La fontaine de Vaucluse - Résultats scientifiques des explorations de 1955 et 1956, *Bull. Inst. Océan.* **1131** 1–35
- Cortes, J.M., Antoranz, A., Menvielle, S., Ratsimandresy, A., Cisneros, J., Ramos, S., Cabrera, M.C., Serrano, V. and Mateu J. (2000) La intrusion marina en el sistema de cuevas Moraig-Toix. Un estudio para la recuperacion del acuífero de la depresion de Benissa (Marina Alta – Alicante). Ve Congreso Geologico de Espana, Alicante, p. 26.
- Douchet, M. (1993) Port Miou: Plongée dans l'eau delà, *Subaqua*, **127**, 1–7.
- Drogue, C., (1989) Continuous inflow of seawater and outflow of brackish water in the substratum of the karstic island of Cephalonia, Greece. *Journal of Hydrology* **106**, 147–153.
- Drogue, C., (1993) Absorption massive d'eau de mer par des aquifères karstiques cotiers. Hydrogeological Processes in *Karst Terranes* (Proceedings of the Antalya Symposium and Field Seminar, October 1990) IAHS **207**
- Fleury, P. (2005) Sources sous-marines et aquifères karstiques côtiers méditerranéens. Fonctionnement et caractérisation. Thèse de troisième cycle, Université Paris VI, 286p.
- Gautier, F., Clauzon, G., Suc, J.-P., Cravatte, J. and Violanti, O. (1994) Âge et durée de la crise de salinité messinienne (Age and duration of the Messinian salinity crisis), *Compte-rendus à l'Académie des Sciences II*, **318** 1103–1109
- Gilli, E. (2001) Compilation d'anciennes mesures de débit à Port Miou. Apport à l'hydrogéologie de la Basse Provence, 7ème colloque d'hydrologie en pays calcaire et en milieu fissuré. *Sciences et techniques de l'environnement*, Besançon, pp. 157–160.
- Gilli, E. (2003) Les karsts littoraux des Alpes Maritimes: inventaire des émergences sous-marines et captage expérimental de Cabbé. *Karstologia*, **40**, 1–12
- Gilli, E., Mangan, C. And Mudry, J. (2004) Hydrogéologie. Objets, méthodes, applications. Dunod edit., Paris, 303 p.
- Julian, M. and Nicod, J. (1984) Paléokarsts et paléogéomorphologies néogènes des Alpes occidentales et régions adjacente (Neogene paleokarsts and paleogeomorphology in the Western Alps, Jura and Provence), *Karstologia*, **4**, 11–18.
- Kohout, F.A., Henry, H.R. and Banks, J.E. (1977) Hydrogeology related to geothermal conditions of the Floridian Plateau. in *The Geothermal Nature of the Floridan Plateau*, Smith D.L., Griffin G.M. (Eds.), vol. 21. Florida Bureau of Geology Special Publication, 1–41.
- Krijgsman, W., Hilgen, F. J., Raffi, I., Sierro, F. J., Wilson, D. S. (1999) Chronology, causes and progression of the Messinian salinity crisis, *Nature*, **400**, 652–655.
- Maurin, V. And Zötl, J. (1965) Salt Water Encroachment in the Low Altitude Karst Water Horizons of the Island of Kephallinia (Ionian Islands), *Hydrologie des roches fissurées*, vol. 2. AIHS, Dubrovnik, pp. 423–438.
- Potié, L., (1974) Captage des résurgences sous-marines d'eau douce. Observations sur les effets du barrage expérimental de Port-Miou. Internal report 74 RT 1001 PM, Syndicat de recherche de Port-Miou, Société des eaux de Marseille.
- Ryan, W. B. F., Hsu K.J. et al. (1973) Initial Reports of the Deep Sea Drilling Project, 13, 1–2, U.S. Government Printing Office, Washington D. C. (1973) 1203–1231

ABOUT THE GENESIS OF AN EXCEPTIONAL COASTAL CAVE FROM MALLORCA ISLAND (WESTERN MEDITERRANEAN). THE LITHOLOGICAL CONTROL OVER THE PATTERN AND MORPHOLOGY OF COVA DES PAS DE VALLGORNERA

JOAQUÍN GINÉS^{1,2}, ANGEL GINÉS^{1,2}, JOAN J. FORNÓS¹, ANTONI MERINO² and FRANCESC GRÀCIA^{1,2}

¹*Departament de Ciències de la Terra, Universitat de les Illes Balears, Palma de Mallorca, Spain.*

²*Federació Balear d'Espeleologia, Palma de Mallorca, Spain.*

The karst developed in the Upper Miocene carbonate rocks of eastern and southern areas of Mallorca island, the so called Migjorn region, is renowned by its well-decorated littoral caves, explored at the end of 19th century by E.A. Martel. The recent exploration of new extensions in Cova des Pas de Vallgornera (Llucmajor municipality), with a current development longer than 60,000 m, has supplied new insights regarding the morphogenetics of such outstanding site from the Migjorn subterranean karst. The observations carried out in this cave suggest that lithological and sedimentological characteristics (architecture of the Upper Miocene reef) exert a strong control over the pattern of this extensive underground system as well as over their morphological features. In short, a very sharp dichotomy exists between the passages and chambers formed in the reef front facies, where abundant corals are present, and those joint-guided galleries excavated in the back reef facies, which show a very lower permeability. Furthermore, this outstanding cave seems to contain evidences of a complex speleogenesis that embraces, besides the coastal mixing zone karstification, a noticeable meteoric water recharge together with a possible basal recharge of hypogenic origin. In this respect, solutional rising flow features are abundant in the inner galleries, being presumably related to the geothermal phenomena recognized along some important faults affecting the area.

1. Introduction

The underground karstification in the carbonate platform that builds up the eastern and southern coasts of Mallorca island (the Migjorn region) had been subject of interest since the end of 19th century. The Coves del Drac, in eastern Mallorca, was explored and investigated by Edouard A. Martel, who is certainly considered as one of the pioneers of European speleology. This French researcher made an accurate description and survey of that cave (Martel, 1896) in which he sustained the action of marine erosion as the exclusive genetic mechanism responsible for its excavation. Some later papers, published during the first third of the 20th century, put under question the marine genesis argued by Martel, proposing alternatively different modalities of cave formation by karstic groundwaters erosion (Maheu, 1912; Faura y Sans, 1926).

It is necessary to wait until the last decade of the past century to find references containing new data about the speleogenesis of Coves del Drac, considered as a paradigmatic example of the endokarst existing in this region of the island. In this context Ginés and Ginés (1992) proposed a new genetic model for the cave, envisaging its excavation linked to the coastal mixing zone. Furthermore, intense cave diving exploration has allowed more precise

topographical and morphological knowledge of the littoral caves in the area (Gràcia et al., 2006, 2007).

During the last few years, detailed investigation of other well-known sites from southern Mallorca signified the exploration of the most extensive cave system in the island, Cova des Pas de Vallgornera, now the longest Mallorcan cave with a development exceeding 60,000 m (Merino et al., 2006, 2007, 2008). These recent findings have supplied new insights about the speleogenesis in Migjorn karst region (Ginés et al., 2008) which is the topic that will be dealt with in this paper, paying special attention to the control played by lithological and sedimentological factors on the organisation of this coastal endokarstic system.

2. Geological setting

The Balearic archipelago is located in the middle of the Western Mediterranean basin, emerging as a prolongation of the Betic mountain chain that runs along the southern part of the Iberian peninsula (Fornós and Gelabert, 2004). The largest island in the Balearics is Mallorca, constituted by an alternating series of mountain ranges and depressed areas disposed roughly parallel in a SW-NE direction as a consequence of extensional movements affecting the island from the Upper Miocene onwards. Within this horst and

graben structure, the mountain areas (called Serres) are built by several thrust sheets mainly of Mesozoic carbonate rocks, folded during the alpine orogeny (from Oligocene to Middle Miocene) and showing a general SE dip.

The depressed areas, or grabens, are infilled by postorogenic materials from the Middle Miocene to Plio-Quaternary. In particular, the Upper Miocene tabular deposits outcrop extensively all along the southern and eastern coast of Mallorca (Fig. 1a), shaping the flat karst region known as Migjorn. This littoral carbonate platform fringes the folded materials of Serres de Llevant and Serres Centrals, reaching sea cliffs up to 100 m high. In the southern end of Migjorn a subsident basin is present (Campos basin) filled up with Plio-Quaternary sediments. In spite of the apparent lithological uniformity of rocks outcropping in the Migjorn region, the Upper Miocene deposits form a rather complex sequence related to the different depositional environments characteristic of tropical carbonate platforms. This complexity causes a noticeable textural variability, producing sharp lateral changes of facies that imply important variations in the permeability of the rocks. According to Fornós et al. (2002), the lower formation of the sequence corresponds to the Calcisiltites with *Heterostegina* unit (Fig. 1b), Lower Tortonian in age, and discordantly disposed over the folded basement; they are sediments deposited in a carbonate ramp environment including well-bedded calcilutites and calcarenites with abundant bioclastic grains.

The Reef Complex unit, with an age ranging from

Upper Tortonian to Lower Messinian, overlies the above mentioned Calcisiltites formation. This unit presents a great textural variability as a function of the complicated reef architecture related to the sea level oscillations and the resulting depositional environments (Pomar et al., 1996; Fornós et al., 2002). The deepest facies associated to the reef development are platform deposits, mainly calcarenitic and calcisiltitic with abundant bioclasts including red algae rodoliths. Talus deposits are present at the fore reef, consisting of well-laminated calcarenites that show a strong dipping towards the basin and great textural variability. The reef front facies, corresponding both to the reef crest and the prograding fore reef, have a framestone texture formed by the growth of coral colonies with the genus *Porites* being clearly dominant. The bedding is not evident in these reef front facies because they form massive bodies without clear laminations. In addition, macroorganisms are abundant and fill up depositional voids, being also present as incrustant organisms growing over the corals. These lithofacies are characterized by a very high primary porosity, along with an important secondary one linked to the aragonitic nature of the coral constructions. The Reef Complex also includes lithofacies corresponding to some restricted environments including lagoon or back reef sediments. In the relatively more dynamic outer lagoon facies, grainstone-packstone textures are dominant together with an increasing percentage of carbonate mud and the presence of isolated coral patches. These outer lagoon facies have a low primary porosity but are relatively permeable owing to fracturing. The sediments that represent the quietest environments

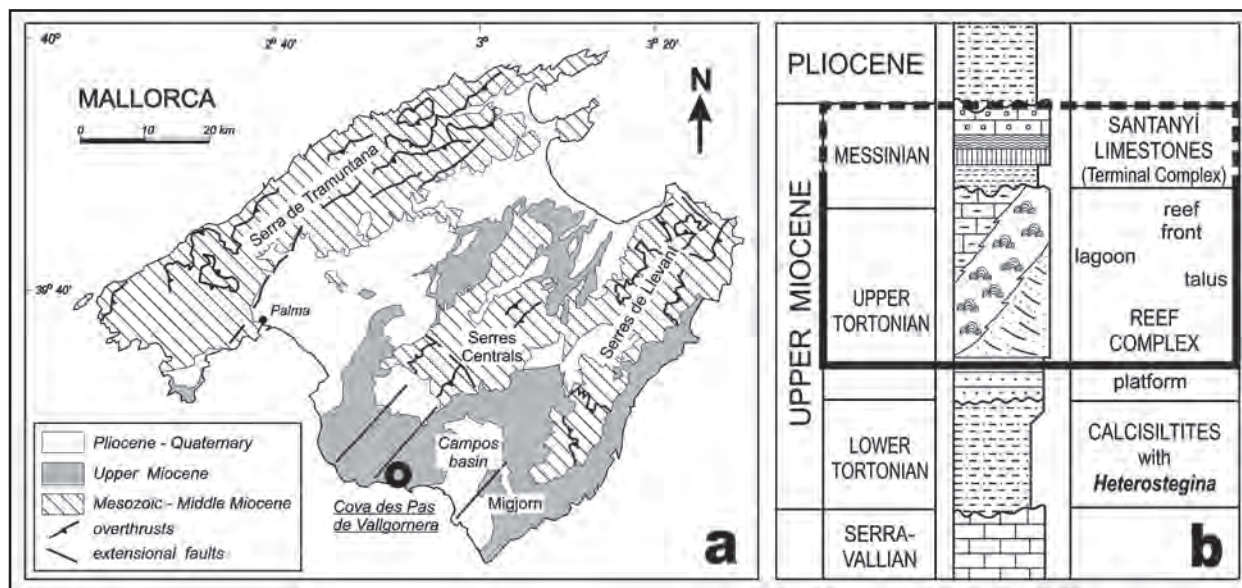

Figure 1: Simplified geological map of the island with the location of the caves (a) and synthetic litho-stratigraphical column of the Upper Miocene in Mallorca (b). The geological units where the endokarst of Migjorn region is developed are highlighted in grey.

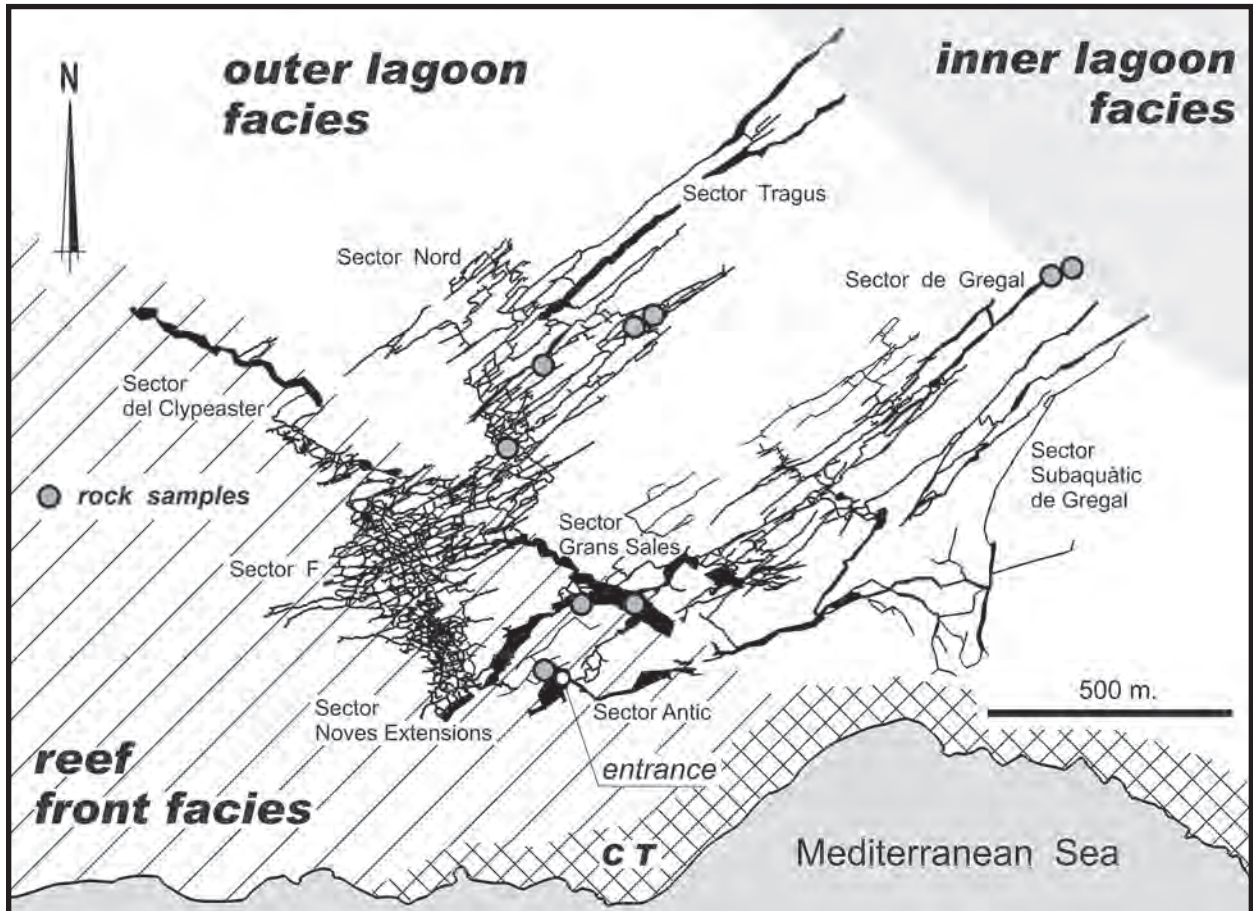

Figure 2: The plan pattern of Cova des Pas de Vallgornera shows clear relations with the facies disposition within the Upper Tortonian Reef Complex in the Lluçmajor platform (southern Mallorca). The Messinian Terminal Complex (CT) outcrops only at the sea cliffs of the area. The location of rock samples used for the lithofacies characterisation is included in the figure.

within the back reef are the inner lagoon facies. In these deposits the mudstone-wackestone textures are predominant, disposed in well-bedded decimetric layers; the permeability of these materials is low and can be considered as aquitards.

The last sequence pertaining to the Upper Miocene corresponds to Messinian (Fig. 1b). This unit known as Santanyí limestones (or Terminal Complex) shows a succession of muddy mangrove facies, estromatolitic deposits and oolitic limestones. The presence of clay and marl layers at the base of the Santanyí limestones, isolates this unit from the hydrogeological point of view. As observed throughout its chambers and galleries, Cova des Pas de Vallgornera is fully developed in the Upper Miocene carbonate rocks, showing the different facies corresponding to the depositional subenvironments that can be individualised within the Reef Complex (Fig. 2). The Santanyí limestones unit (also called Terminal Complex) outcrops only in a very limited manner on the

sea cliffs of the area, where it is disposed over the Reef Complex by means of a clear erosion surface; up till now, the development of the cave does not reaches this unit.

3. Cave morphology and lithological control

The cave starts with a succession of breakdown chambers quickly reaching the phreatic level (the so-called Sector Antic, including the entrance chamber), which connect with a spectacular assemblage of aquatic galleries richly decorated with speleothems (Sector Noves Extensions). A tight passage located at the furthest end of that sector gives access to the important extensions discovered in 2004, beginning with several big chambers disposed in a NW-SE trend. Among them, the Sala Que No Té Nom is really outstanding for its dimensions (200 by 80 m). From this part of the cave, known as Sector Grans Sales, up to six additional sectors are distinguished (Fig. 2), being roughly located in two different levels: the lower one develops near the current water table (or below it) including Sector de Gregal and Sector Subaquàtic de Gregal, and the higher

one runs over 11 m above the brackish phreatic waters embracing Sector Tragus, Sector Nord and Sector F. Finally, the Sector del Clypeaster is mainly developed near the water table but it rises progressively towards its NW end. The inner parts of Cova des Pas de Vallgornera show an irregular maze pattern in which up to seven main galleries can be clearly differentiated. These galleries run parallel in a SW-NE direction along distances exceeding one kilometre. Underwater explorations have revealed the presence of extensive passages situated below the current phreatic level. The total development of the cave today surpasses 60,000 m; detailed descriptions of this site are available in Merino et al. (2006, 2007, 2008).

Morphological features are really variegated, owing to the notable extension of the endokarstic system that hosts well-differentiated underground environments. Breakdown processes are ubiquitous all around the cave, being particularly important in some specific sections like Sector Antic and Sector Grans Sales. These sectors are connected between them by extensive phreatic brackish pools (Sector Noves Extensions) where solutional spongework features are omnipresent together with a rich speleothem ornamentation; some maze areas also develop near the current water table. In this SW part of the cave system, strongly corroded coral structures are quite frequent, producing solutional voids of irregular forms and sizes (Fig. 3a and 3b). The pattern and morphology of the cave change in a radical manner from Sector Grans Sales, in the inland direction, to joint-guided galleries (Fig. 3c). Starting from the network maze of Sector F, an array of parallel galleries are individualised towards the NE which are rigidly controlled by prominent joints or fractures. Phreatic solutional features shape the walls of these passages, being dominant the dissolution pockets of diverse size and morphology; no true scallops are present. The horizontal solution notches are well represented, whose lower part form dip levels or facetes showing smooth dissolution channels incised on their slopes. In this inner part of the cave, some kinds of solutional ascending channels are found which seem to be related to an hypogenic origin (Klimchouk, 2007).

Speleothems are widely distributed throughout the entire cave and are exuberant in some galleries; the richness and variety of forms is unique in Mallorca. Besides the dripping water speleothems, there are exceptional groups of helictites as well as abundant subaqueous deposits, both phreatic overgrowths (sea level controlled) and vadose crystallisations related to the extensive gours existing in the passages of Sector Tragus. Some types of speleothems not

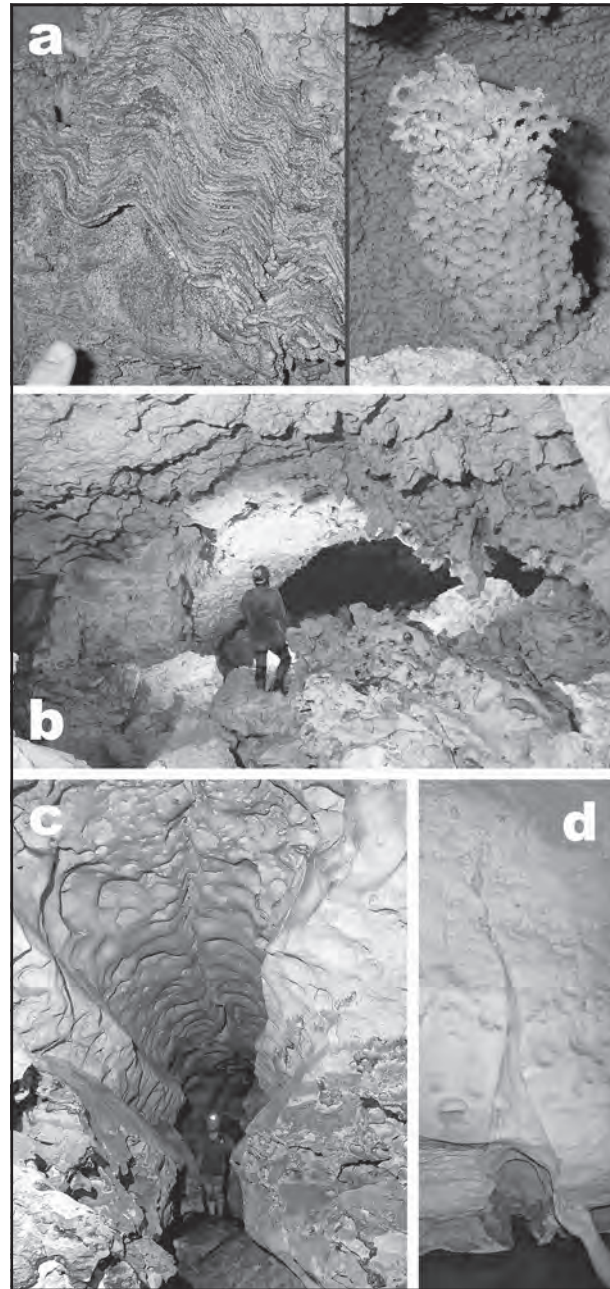

Figure 3: Cova des Pas de Vallgornera; morphological aspects of its passages and chambers. (a) detail views of coral structures affected by solutional processes; (b) the passage called Galeria del Mig Quilòmetre (Sector del Clypeaster) runs over 500 m all along the reef front, without any structural control and showing spectacular dissolution features on its whole cross-section; (c) view of a joint-guided gallery developed in the outer lagoon facies and shaped with spectacular dissolution features (notches, bevels, pockets of diverse size...); (d) conspicuous solutional rising channels, of a possible hypogenic origin, are well-represented particularly in the passages from Sector de Gregal (Photos: Antoni Merino).

usual in Mallorca are represented (Merino, 2007) like, for example, several cave rims located in the inner passages of the cave.

The complex plan development of the system fits, in general terms, in the maze caves category defined by Palmer (1991, 2007). Nevertheless, its labyrinthine pattern is quite heterogeneous ranging from a spongiform-ramiform disposition in the south-western sectors, where the collapse processes are abundant, to a crude maze of structurally controlled galleries but without forming an evident regular network (Fig. 2).

The different depositional environments, represented within the Upper Miocene (Tortonian) reef complex, determine the existence of well-individualised morphogenetic suites as a function of the lithological and hydrogeological characteristics of these young carbonate rocks. In this sense, a clear dichotomy arises between those parts of the cave excavated in the reef front facies and the galleries developed in the back reef facies. On one hand, the cave zones showing generalised breakdown processes occur in the highly porous reef front facies, where the coral structures are omnipresent and affected by intense differential dissolution phenomena (Fig. 3a). A paradigmatic example of speleogenesis fully conditioned by the reef barrier topography is located at the NW end of Sector del Clypeaster (Fig. 2). In this section, a wide gallery develops over 500 m of length as a consequence of the solutional excavation of the coral barrier (Fig. 3b).

This passage lacks any structural guidance, showing a rather wandering trajectory conditioned by the reef front architecture. On the other hand, and in contraposition to the anterior examples, the extensive network of galleries that run towards the NE in an inland direction developed in the outer lagoon facies (Pomar et al., 1996) of the Tortonian reef complex. These carbonate materials are quite massive and less permeable (less porous and more calcisiltitic) than the reef front facies being affected by SW-NE fracturing, roughly parallel to the main extensive faults responsible for the subsidence of Campos basin (see Fig. 1). The passages that are characteristic of the outer lagoon facies consist in joint-guided galleries whose walls appear completely sculptured by variegated solutional features (Fig. 4). These long passages also exhibit some collapse morphologies where coral patches are present within the outer lagoon deposits; in this manner, frequent widening in these rectilinear galleries are the result of the massive dissolution of isolated coral structures.

The northeast end of the long galleries integrating Sector Tragus and Sector de Gregal seem to be coincident with

another lithological change, particularly with the presence of deposits attributed to the inner lagoon facies of the reef complex. In the terminal parts of these sectors the rock becomes less massive, showing a disposition in beds of calcisiltitic and marly materials ranging in thickness from decimetric to metric. Up to now, the major galleries trending SW-NE in the inner sectors of the cave have an abrupt finishing at a rather constant distance with respect to the deduced position of the Tortonian reef barrier (Fig. 2).

4. Involved speleogenetic mechanisms

The coastal mixing zone aggressiveness has been invoked when explaining the genesis of littoral caves in Migjorn region of Mallorca island (Ginés and Ginés, 1992; Merino, 2000; Gràcia et al., 2006). Certainly, those sectors of Cova des Pas de Vallgornera disposed closer to the coast line are very similar to the classic coastal caves of eastern Mallorca, where active dissolution at the mixing zone has been reported (Gràcia et al., 2007). In all the cases, breakdown processes become determinant in shaping the subterranean karst of Migjorn, as was pointed out previously (Ginés, 2000; Ginés and Ginés, 2007).

In spite of the feasible participation of coastal mixing processes in the genesis of Cova des Pas de Vallgornera, its inner sectors show quite different morphological features consisting in long conduits integrated in an irregular network maze. These galleries seem to be the result of speleogenetic processes that occurred in shallow phreatic conditions within a littoral aquifer effectively drained by prominent joints and fractures. Although the current rainfall is low (aprox. 400 mm/yr), the meteoric recharge of the littoral aquifer must be taken into account, as it is evidenced by several episodes of fine detritic sedimentation observed in the passages of Sector Tragus and Sector de Gregal.

Furthermore, it must be highlighted the presence of solutional ascending flutes that resemble the rising flow morphologies described by Klimchouk (2007). They are rising channels very different in size (from millimetres to decimetres in width and up to more than one metre long), etched in the overhanging walls of passages from the inner parts of the cave; some of them (Fig. 3d) are similar to the *bubble trails* reported by Palmer (2007). These features, together with other morphological and sedimentary evidences (small galleries ending in cul-de-sac, feeder-like descending hollows, crusts rich in Mn and Fe), could correspond to an hypogenic basal recharge related to the geothermal phenomena associated with the extensional faults causing the Campos basin subsidence

(see Fig. 1). According to this point of view, Cova des Pas de Vallgornera seems to constitute a complex cave example (Ginés et al., 2008) due to the confluence of three well-differentiated speleogenetic vectors: coastal mixing zone phreatic dissolution, epigenic karstification related to the underground drainage of meteoric precipitations and, finally, an hypogenic basal recharge linked to geothermal phenomena (Fig. 4).

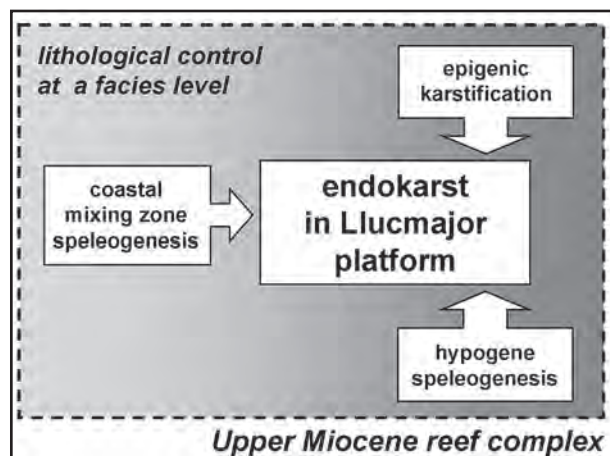

Figure 4: The genesis of Cova des Pas de Vallgornera is a complex matter owing to the confluence of three speleogenetic vectors that have acted altogether, but conditioned by strong lithological factors.

Some comments must be addressed about the base level position having determined the main speleogenetic phases in the system. Although the participation of meteoric recharge must be taken into account as previously postulated, the base level position has been tightly dependent on the Quaternary glacioeustatic oscillations of Mediterranean Sea. Introducing more complexity to this topic, this western portion of Migjorn karst region is affected by distensive tectonic movements from the end of Tertiary to Quaternary times, linked to the faults delimitating the Campos basin. As a result, there is a pronounced tilting of the Upper Miocene platform from the uplifted western areas (where the cave system is located) to the easternmost depressed areas corresponding to the Campos basin. The presence of extensive mazes near current sea level, as well as up to 11 m above it, could be a consequence of this recent tectonic tilting. It is not clear if all the maze areas are synchronous in origin and differentially uplifted after formation or, as an alternative, the genesis of the system is diachronic according to the recent tectonics of the region. Whatever the answer, the main speleogenetic phases must correspond undoubtedly to Pliocene times on the basis of the evolutionary trends of endemic mammal remains recovered inside the cave (P. Bover, pers. comm.).

5. Conclusions

Cova des Pas de Vallgornera is a really unique cave within the endokarst of the Migjorn region of Mallorca island. Its notable dimensions (more than 60,000 m of current development) together with the exuberant and rich speleothems place the cave at a very relevant position, even at an international level, regarding the magnitude and scenic values of the system. But the main interest of this cave lies in its geological and geomorphological aspects, as has been put forward in this paper. This exceptional site clearly shows the strong control imposed by lithological factors (architecture of the Upper Miocene reef) on the pattern and the morphological features of the system. In the reef front facies, being plentiful of coral constructions, the collapse chambers and spongework mazes are dominant, whereas in the back reef facies an irregular network of joint-guided galleries is the ruling tendency. Furthermore, the cave supplies evidences of a multi-folded speleogenesis that includes the coastal mixing zone dissolution, a noticeable epigenic recharge as well as a possible basal recharge of hypogenic origin.

Acknowledgments

These investigations are integrated within the research project CGL2006-11242-C03-01/BTE of the *Ministerio de Ciencia e Innovación - FEDER*. We are grateful to the following colleagues for their contribution during the field tasks: Bernat Clamor, Toni Croix, Mateu Fiol, Pere Gamundí, Andreas Kristofersson, Guillem Mulet and Toni Mulet. Comments from Paul J. Moore have contributed to improve substantially the original manuscript.

References

- Faura y Sans, M. (1926) Cuevas de Mallorca. XIV Cong. Geol. Intern., Inst. Geol. España, Gráficas Reunidas, S.A., Madrid, 78 p.
- Fornós, J.J., and Gelabert, B. (2004) Balears. In *Geología de España*, Vera, J.A. (Ed.), Sociedad Geológica de España – IGME, Madrid, 450–464.
- Fornós, J.J., Pomar, L., and Ramos-Guerrero, E. (2002) Balearic Islands. In *The Geology of Spain*, Gibbons, W. and Moreno, T. (Eds.), The Geological Society, London, 327–334.
- Ginés, A. (2000) Patterns of collapse chambers in the endokarst of Mallorca (Balearic islands, Spain). *Acta Carsologica*, **29**:2, 139–148.
- Ginés, A., and Ginés, J. (1992) Las Coves del Drac

- (Manacor, Mallorca). Apuntes històrics y espeleogenéticos. *Endins*, **17-18**, 5–20.
- Ginés, A. and Ginés, J. (2007) Eogenetic karst, glacioeustatic cave pools and anchialine environments on Mallorca Island: a discussion of coastal speleogenesis. *International Journal of Speleology*, **36:2**, 57–67.
- Ginés, J., Ginés, A., Fornós, J.J., Gràcia, F., and Merino, A. (2008) Noves observacions sobre l'espeleogènesi en el Migjorn de Mallorca: els condicionants litològics en alguns grans sistemes subterranis litorals. *Endins*, **32**, 49–79.
- Gràcia, F., Clamor, B., Fornós, J.J., Jaume, D., and Febrer, M. (2006) El sistema Pirata - Pont - Piqueta (Manacor, Mallorca): geomorfologia, espeleogènesi, hidrologia, sedimentologia i fauna. *Endins*, **29**, 25–64.
- Gràcia, F., Fornós, J.J., Clamor, B., Febrer, M., and Gamundí, P. (2007) La Cova de sa Gleda I. Sector Clàssic, Sector de Ponent i Sector Cinc-Cents (Manacor, Mallorca): geomorfologia, espeleogènesi, sedimentologia i hidrologia. *Endins*, **31**, 43–96.
- Klimchouk, A.B. (2007) Hypogene speleogenesis: hydrogeological and morphogenetic perspective. National Cave and Karst Research Institute, Special Paper 1, Carlsbad, New Mexico, 106 p.
- Maheu, J. (1912) Exploration et flore souterraine des cavernes de Catalogne et des Iles Baléares. *Spelunca*, **8:67-68**, 1–108.
- Martel, E.A. (1896) Sous Terre. Cueva del Drach, a Majorque. *Ann. Club Alpin Franc.*, **23**, 1-32.
- Merino, A. (2000) Nuevas extensiones de la Cova des Pas de Vallgornera (Llucmajor, Mallorca). *Endins*, **23**, 7-21.
- Merino, A. (2007) Solutional sculpturings and uncommon speleothems found in the Cova des Pas de Vallgornera, Majorca, Spain. *NSS News*, **65:9**, 14–20.
- Merino, A., Mulet, A., and Mulet, G. (2006) La Cova des Pas de Vallgornera: 23 kilòmetres de desarrollo topografiado (Llucmajor, Mallorca). *Endins*, **30**, 29–48.
- Merino, A., Mulet, A., Mulet, G., Croix, A., and Gràcia, F. (2007) La Cova des Pas de Vallgornera (Llucmajor, Mallorca): 40 kilòmetres de desarrollo topografiado. *Endins*, **31**, 101–110.
- Merino, A., Mulet, A., Mulet, G., Croix, A., and Gràcia, F. (2008) La Cova des Pas de Vallgornera (Llucmajor, Mallorca): Alcanza los 55 kilòmetres de desarrollo topográfico. *Endins*, **32**, 33-42.
- Palmer, A.N. (1991): Origin and morphology of limestone caves. *Geological Society of America Bulletin*, **103**, 1–21.
- Palmer, A.N. (2007) Cave geology. Cave Books, Dayton, Ohio, 454 p.
- Pomar, L., Ward, W.C., and Green, D.G. (1996) Upper Miocene reef complex of the Llucmajor area, Mallorca, Spain. In *Models for carbonate stratigraphy from Miocene reef complexes of the Mediterranean regions*, Franseen, E., Esteban, M., Ward, W.C., and Rouchy, J.M. (Eds.) SEPM Concepts in Sedimentology and Paleontology 5, 191–225.

CAVE SURVEYING AND CAVE PATTERNS IN THE SOUTHEASTERN COASTAL KARST OF MALLORCA ISLAND (SPAIN)

ANGEL GINÉS^{1,2}, JOAQUIN GINÉS^{1,2}, FRANCESC GRÀCIA^{1,2} and JOAN J. FORNÓS¹

¹*Departament de Ciències de la Terra, Universitat de les Illes Balears, Palma de Mallorca, Spain.*

²*Federació Balear d'Espeleologia, Palma de Mallorca, Spain.*

Knowledge on cave patterns obviously relies on available cave surveys. Cave mapping of the coastal caves of Mallorca (western Mediterranean) started early in the 19th century, with the exploration and surveying of almost 2 km of large rooms in the celebrated Coves del Drac by Edouard A. Martel. Over the years, the large amount of topographical data collected by conventional (non cave diver) cavers seem to confirm that the most typical caves in the Upper Miocene platform from southeastern Mallorca (the Migjorn karst region) consist basically of one or more collapse chambers connected in an apparently random pattern and drowned partially by the postglacial rise of the water table. New cave diver explorations and detailed underwater surveying increased knowledge of the coastal cave systems from the Migjorn region. This new data suggests that previous assumptions about the patterns of the caves developing in this eogenetic karst must to be updated in order to embrace the information provided by cave diver mapping. Three major new evidences should be outlined: (1) connectivity between caves becomes greater than expected; (2) long joint-guided passages are occasionally found below the water table; and (3) extensive collapse features also characterize the main underwater segments of these coastal caves.

1. Introduction

Interest in coastal karst and coastal caves have increased during the last few decades because of their particular hydrogeological and speleogenetical characteristics, which differ from karst and caves that develop in continental settings. Karst caves developed in coastal areas have been explained as the result of dissolution from the mixing of waters with different chemical compositions, and it is assumed that distinctive cave patterns could be expected in such special geochemical and hydrodynamical environment. These caves commonly exhibit spongework and ramiform morphology believed to reflect geochemical processes including the mixing of fresh and saline water and hydrodynamics of freshwater lens.

Knowledge of caves depends on the availability of accurate cave maps. Surveying of caves located in the immediate vicinity of the sea is frequently hampered by the closeness of the water table. Many coastal caves appear drowned in most of their real sections by the postglacial sea-level rise and the consequent rise of the water table. For this reason, cave mapping in these partially-submerged karst systems requires accurate and detailed survey tasks to account not only for the air-filled rooms and passages, but also the water-filled extensions of the caves.

One of the main goals in cave surveying is the disclosure and subsequent explanation of cave patterns. This is especially true for coastal karst because comparisons between cave

patterns may reflect different speleogenetic processes, such as the relationship between cave development and glacio-eustasy, the role of breakdown in the evolution of the caves or the bioclimatic, geochemical and structural constraints involved. Since significant information can be obtained using detailed cave maps, a discussion on surveying criteria and standardization of coastal-cave maps seem worthwhile.

Cave surveying in the Migjorn region—a coastal karst area located in the southeastern part of Mallorca Island (western Mediterranean)—has a long history of exploration, mapping, and scientific debate on the mechanisms driving cave development, starting in the second half of the 19th century. In short, three main periods can be distinguished: (1) the pioneer descriptions of a few celebrated Migjorn caves (including the Martel map of Coves del Drac); (2) the conventional-caver mapping of many caves of the region that suggested a typical and repetitive pattern made up of apparently isolated collapse chambers that coalesce randomly; and (3) recent mapping by cave divers demonstrating underwater connections between caves and in some cases even with the sea.

2. Cave surveying: A Matter of Accessibility

Producing accurate and detailed cave maps requires overcoming technical problems of exploration involved with each cave and most importantly traversing the minimum penetrable-size of all cave passages. The availability of cave maps remains a function of exploration, which increases

with time. Direct observation –and consequently cave surveying– is limited in some cases by the presence of fluids (e.g. high concentrations of carbon dioxide or, more commonly, water) which require specific exploration equipments. Nonetheless, the most obvious limit for cave surveying is the minimum size of the cavity to explore, whereby many sections of a cave are out of the access of cavers and can only be interpreted through indirect observations.

Inaccessibility accounts for most of the unsatisfactory knowledge of coastal caves and coastal cave-systems in all littoral karst areas as the Holocene rise in sea level flooded these low-lying caves. Furthermore, eogenetic karsts are not prone to promote the development of well structured cave conduits, in spite of its inherent great hydraulic conductivity, impeding the direct observation and mapping of the myriads of tiny interconnected voids that transmit the water toward the sea. On the other hand, it is still hard to lay down solid generalizations, because only a small number of locations around the world are on the base of the current theoretical approach to the coastal karst systems

(e.g. Bahamas, Guam, Mallorca, Florida, or Yucatán) and comparison between these coastal locations is still a task to develop in the near future.

3. Cave Surveying: A Matter of Methodology and Sampling Strategy

Cave surveying and cave mapping are more than a descriptive task. Although some cave features are striking, many significant features are frequently ignored in the most common cave maps. Selective criteria are applied implicitly when the cavers choose what shape better describes the perimeter of a cave, or when they plot inside such wall-perimeter the most relevant features to enclose in the drawing. Cave maps are the only way to study the pattern of the caves, but these maps are far from objective representations.

An alternative approach is to assume these facts as the uncertainty bias of a particular “sampling method”, thereby avoiding unexpected “graphic artifacts” that would introduce misleading information through the mapping practices. In this way, cave surveying becomes a specific

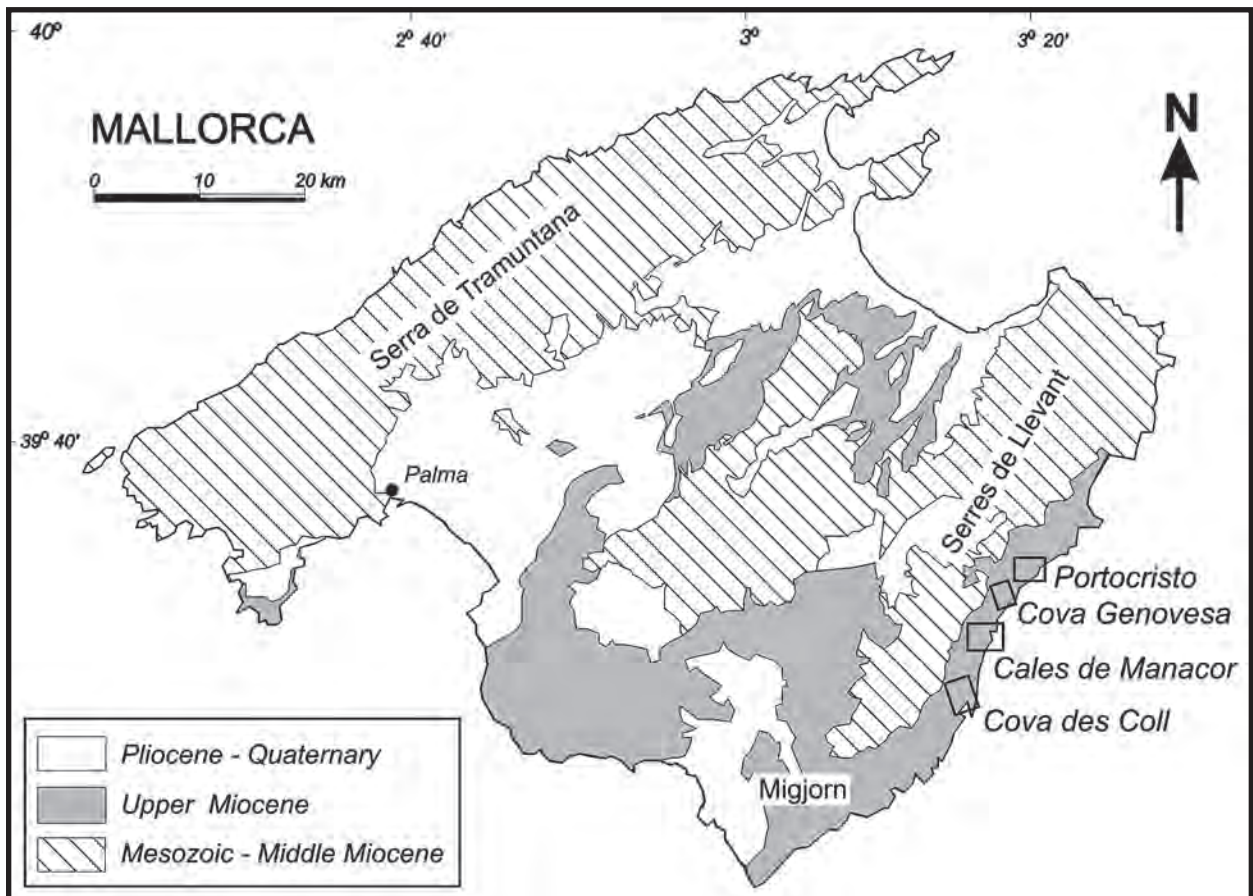

Figure 1: Simplified geological map of Mallorca island showing the location of the caves and the cave-areas discussed in the text.

sampling method for collecting accurate field data. For instance, in the case of the Migjorn karst of Mallorca (Fig. 1), our current analysis of coastal cave patterns relies on a three-level approach based on the following scale of increasing size and complexity: cave-segments, individual caves and cave-systems.

4. Maps of Cave-Segments in the Karst of Southeastern Mallorca

Detailed analysis of particular cave-segments may allow identify diagnostic features that relate to specific geochemical environments. For example, large chambers may relate to dissolution voids that develop similar to flank margin caves, or cave passages may reflect active flow and dissolution processes similar to conduits that develop in

telogenetic settings. Additionally, it is important to report significant assemblages of solutional forms, as well as to measure their size and frequency of appearance. Cave maps provide little information about small-scale solution features (e.g. presence or absence of solution notches, scallops, etc). On larger scales, however, some significant data can be obtained by analyzing chambers and passages in plan view. Cross sections are also informative because their shapes commonly provide insight on its genesis. In addition, the cave floor of rooms and passages requires detailed attention when trying to recognize the presence of sediments, speleothem pavements, collapse boulders or in situ rock.

In the eogenetic karst of Migjorn, cavers have traditionally focused on the richness in speleothems, the widespread

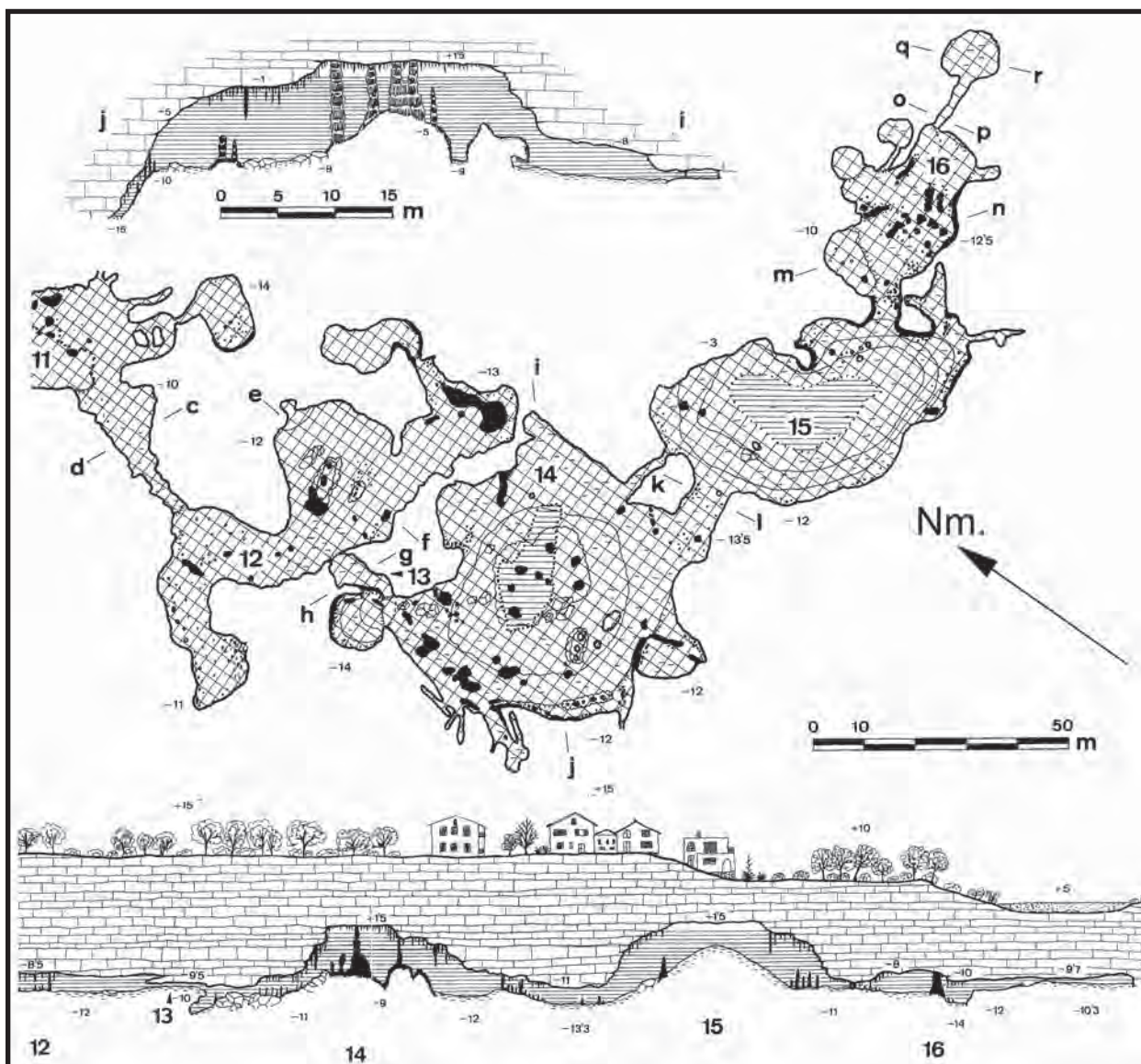

Figure 2: Detailed scuba diver survey of a sector from Cova Genovesa. The presence of breakdown features and speleothems is easy to recognize with the aid of this kind of underwater mapping.

occurrence of breakdown features (boulder heaps and collapsing vaults), and the scarcity of former solutional evidences (that become progressively dismantled by breakdown). This is easy to recognize within the whole background of cave surveys produced by Majorcan cavers till present. The vast majority of available maps depict, in detail, the recurrent collapse chambers floored with fallen blocks and speleothems, even below the water table (Fig. 2). More recently, however, mapping by cave divers has incorporated specific symbols in order to indicate the presence of conspicuous solutional features, such as certain assemblages of corrosion forms including spongework morphology and single solutional-conduit passages (Gràcia et al., 2005, 2006, 2007). This information has an additional value because solutional voids appear structured in horizons that are currently located between 1 and 15 m below the water table; being therefore inaccessible for conventional cavers.

5. Maps of Individual Caves in the Karst of Southeastern Mallorca

Maps of individual caves in southeastern Mallorca

commonly fail to reflect entire cave systems as new discoveries by cave divers have substantially expanded the old maps. Since most cave maps reflect an “artifact of the current stage of exploration” of the real cave, the new discoveries by cave divers allow the old surveys to be substantially modified. This “expansion” of previous cave maps is especially evident in light of the coastal caves drowned as a result of the Holocene sea-level rise.

In the eogenetic karst of southeastern Mallorca, excellent examples of caves illustrating the “artificial changes in cave pattern” result from new exploration techniques. For example, the caves surrounding Portocristo harbour (Fig. 3) and Cova Genovesa (Fig. 4) were previously explored by conventional cavers who produced detailed cave maps that stopped at sea-level pools.

The karstic area around Portocristo encloses two celebrated show caves, Coves dels Hams and Coves del Drac, that reflect the typical trends of caves from the Migjorn karst region (Ginés and Ginés, 1989; Ginés 2000a, 2000b). These

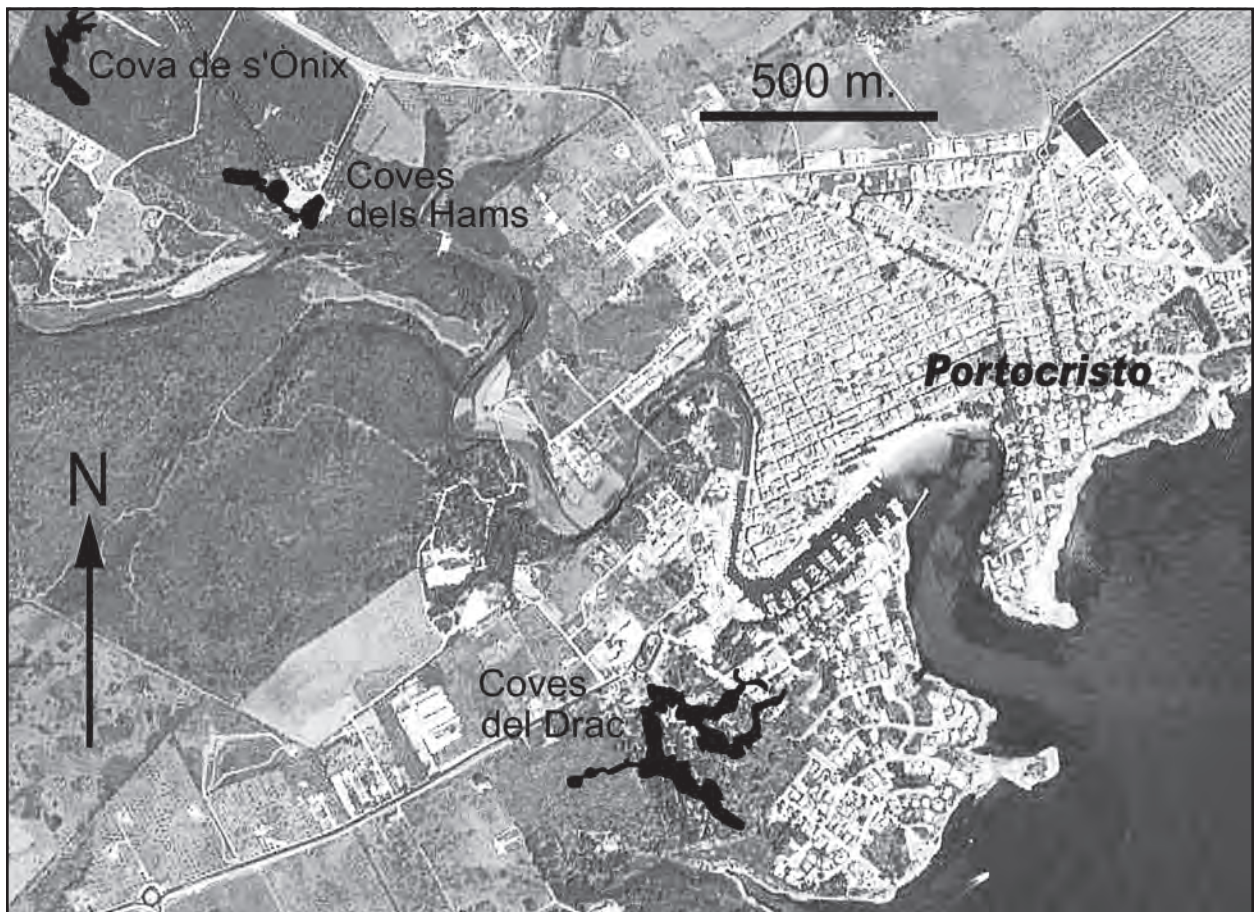

Figure 3: Plotting of the main caves located around Portocristo harbour. Note the wandering trend and the remarkably non-directional path of the celebrated Coves del Drac cavern, placed just between the incised creek of Torrent de ses Tallioles and the small bight of Cala Murta visible at the southern side of the figure.

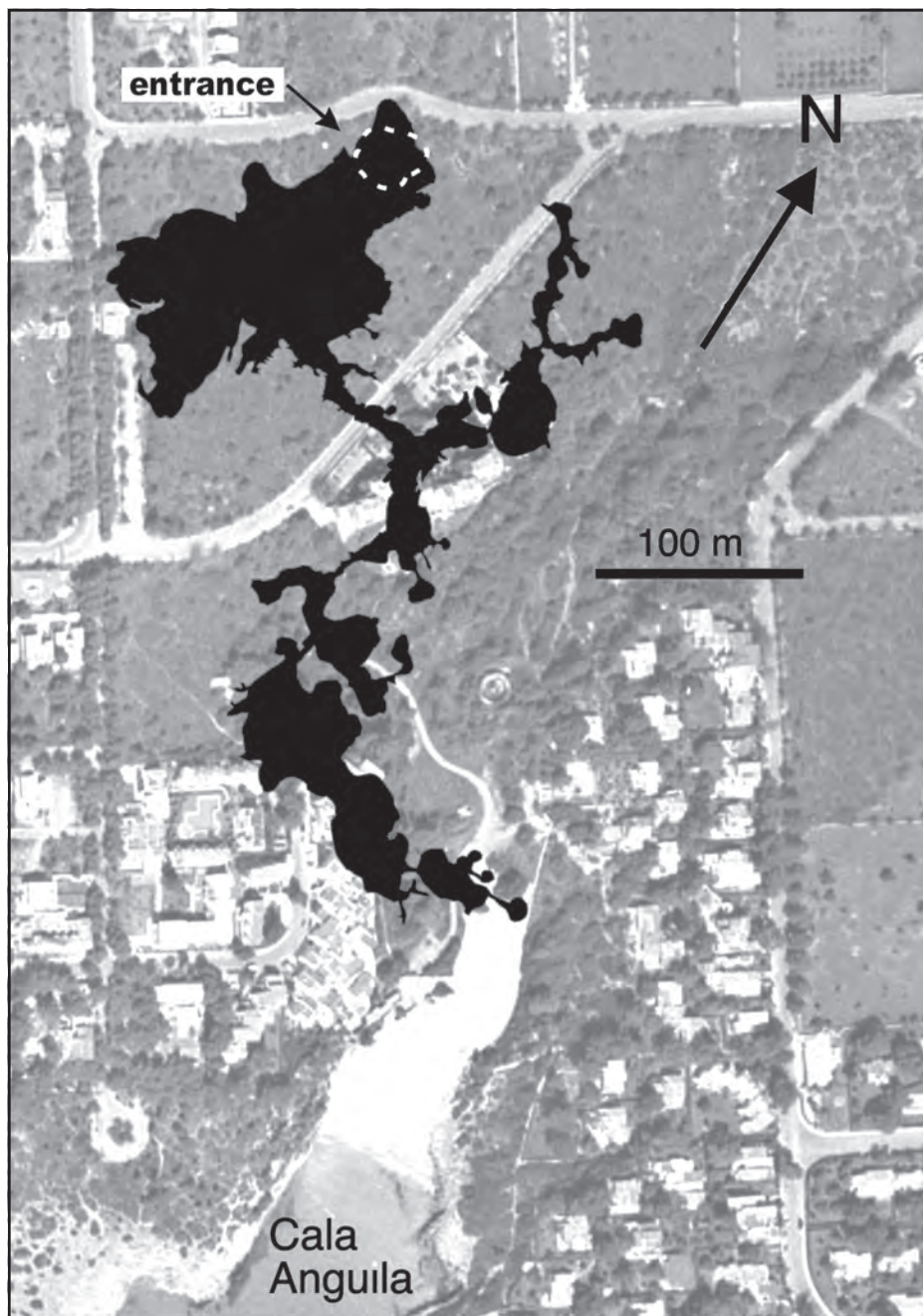

Figure 4: Map of Cova Genovesa plotted over an aerial photograph of Cala Anguila bight.

caves exhibit wandering set of large breakdown-vault units, 30 to 50 m wide, connected randomly by local collapses and surrounded by peripheral brackish pools. This pattern is easy to recognize throughout the maps published on these caves over the last century (Martel, 1896; Maheu, 1912; Faura y Sans, 1926; Ginés and Ginés, 1992; Ginés et al., 2007). The updated cave surveys (Fig. 3) highlight the remarkably non-directional path of Coves del Drac, in spite of its location between the incised creek of Torrent de ses Talaioles and the small bight of Cala Murta. Until now, only some sporadic cave-diver explorations added significant

underwater extensions in Coves del Drac (Clarke, 1991), although additional passages are expected if underwater surveying continues.

In addition to the foreseeable discoveries in Portocristo, Cova Genovesa also provides a good example of the striking changes in its plan-view map resulting from underwater exploration and careful mapping (Fig. 4). Twenty years ago, the known cave included only two typical collapse chambers near the entrance. Recent mapping has demonstrated a wandering path running towards de Cala Anguila bight, hidden from the “conventional-cavers” below the modern water table (Gràcia et al., 2003). Such discoveries suggest the previously known caves, namely those accessible without scuba equipment, can be interpreted as just the topmost part of extensive systems of coalescing chambers, whose “solutional roots” are mainly located more than ten meters below the present sea level.

6. Maps of Cave-Systems in the Karst of Southeastern Mallorca

The cave systems can be defined as “a collection of caves interconnected by enterable passages or linked hydrologically” or as “a cave with an extensive complex of chambers and passages” (Gillieson, 1996). As could be expected, only few of the surveyed caves fit within this third scale-level of standardized interpretation. Namely, Cova des Coll, Cova des Ases, Coves de Cala Varques and Pirata-Pont-Piqueta system have several connected entrances, and extensive cave complexes including Cova des Pas de



Figure 5: Map of Cova des Coll plotted over an aerial photograph of Portocolom harbour.

Vallgornera and Cova de sa Gleda have only one known entrance.

As a result of systematic cave-diver explorations carried out during the last decade in the sea-level pools of many formerly “well-known” caves from the southeastern karst of Mallorca, several groups of caves were successfully connected underwater. The exploration of two of them (Cova des Coll and Cova dets Ases) led to a direct opening to the sea, demonstrating a hydrological connection between the caves and the brackish water outlets existing along the coastal line via conduits negotiable by cave-divers. Cova des Coll has today more than 7 km of surveyed passages, of which 5.5 km are submerged (Gràcia et al., 2005), and outstands by its rather directional trend (Fig. 5). The pattern of the cave includes not only several collapse chambers, but also remarkable joint-guided solutional passages that locally generate mazes of conduits. Cova dets Ases is an array of typical collapse chambers connected with the sea through a shallow underwater passage (Gràcia et al., 1997).

Around the Cales de Manacor karst area (Fig. 6) successful

explorations provided insight on the pattern of coastal cave-systems of this part of Mallorca. Three cave systems that developed not far from the coast showed no direct drainage towards the sea. Cova de sa Gleda has more than 10 km of submerged chambers and large passages (Gràcia et al., 2007). Coves de Cala Varques consists of three connected collapse caves that surround the homonymous bight (Gràcia et al., 2000). Pirata-Pont-Piqueta system shows wandering and chaotic paths (longer than 3 km) characterized by the coalescence of eight major collapse chambers, without efficient hydrological connectivity between them, and opened to the surface through three cave entrances (Gràcia et al., 2006). Ramiform patterns are dominant in these three neighbouring cave systems (Fig.6).

7. Conclusions

Accurate cave maps are essential for the analysis of cave patterns and suggest relevant information such as detailed surveys and complementary data should be included in these maps. This is particularly true in coastal karst areas, where specific constraints (e.g. drowned extensions of many cave systems) restrict conventional-cavers from access to the

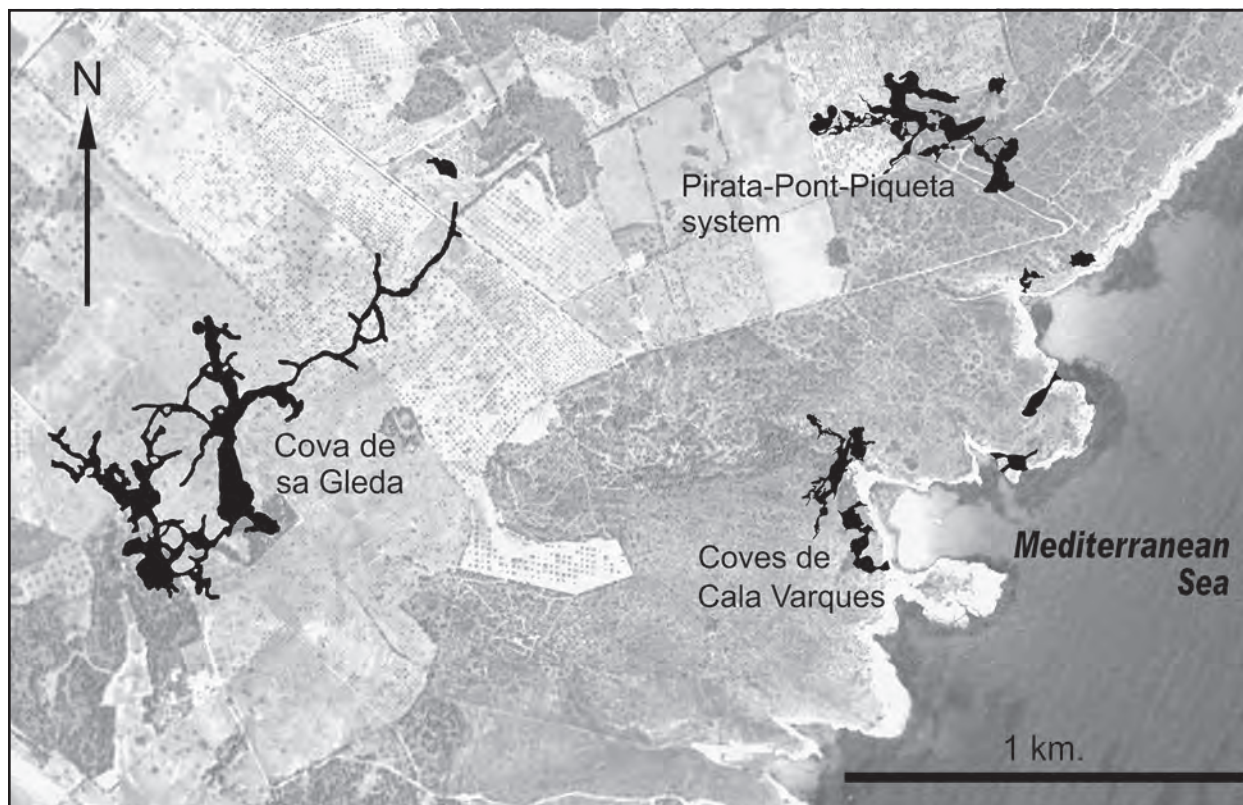

Figure 6: Plotting of the main caves located in Cales de Manacor area. Ramiform patterns are dominant, lacking apparent direct drainage towards the sea.

lower passages of many caves. The presence of sea-level pools –disrupting the connectivity between caves and hampering the perception of its real pattern– is a general rule in these caves.

Our experience in the karst of southeastern Mallorca (the so called Migjorn region) demonstrates the importance of accurate and detailed cave mapping. Such standards can provide a major significance in the studies of coastal caves. For example, the cave surveys of Coves del Drac (Faura and Sans, 1926), Cova Genovesa (Gràcia et al., 2003; Fig. 4) or Cova des Pas de Vallgornera (Merino et al., 2008) are much more than simple description-tools, but instead support inference of speleogenesis (Ginés and Ginés, 2007; Ginés et al., 2008). In this way, we are suggesting that detailed underwater surveys must be encouraged –in spite of the difficulties– with the aim of improving our knowledge on coastal cave morphogenesis. Furthermore, we introduce an open discussion about what data-standards could be more advisable regarding future comparisons between coastal cave maps from different coastal settings of the world.

Acknowledgements

This work was partially supported by the research fund of *Ministerio de Ciencia e Innovación* – FEDER, CGL2006-

11242-C03-01/BTE. Thanks are due to Paul J. Moore for his aid in the improvement of the former manuscript.

References

- Clarke, O. (1991) Diving in Drach. Descent, **101**, 32–33.
- Faura y Sans, M. (1926) Cuevas de Mallorca. XIV Cong. Geol. Intern., Inst. Geol. España, Gráficas Reunidas, S.A., Madrid, 78 p.
- Gillieson, D. (1996) Caves: Processes, Development and Management. Blackwell, Oxford, 324 p.
- Ginés, A. (2000a) Patterns of collapse chambers in the endokarst of Mallorca (Balearic islands, Spain). *Acta Carsologica*, **29:2**, 139–148.
- Ginés, A., and Ginés, J. (1992) Las Coves del Drac (Manacor, Mallorca). *Apuntes históricos y espeleogenéticos*. *Endins*, **17-18**, 5–20.
- Ginés, A., and Ginés, J. (2007) Eogenetic karst, glacioeustatic cave pools and anchialine environments on Mallorca Island: a discussion of coastal speleogenesis. *International Journal of*

- Speleology, **36:2**, 57–67.
- Ginés, J. (2000b) El Karst litoral en el levante de Mallorca: Una aproximación al conocimiento de su morfogénesis y cronología. Unpublished PhD Thesis. Universitat de les Illes Balears, Palma de Mallorca, 595 p.
- Ginés, J., and Ginés, A. (1989) El Karst en las Islas Baleares. In *El Karst en España*, Durán, J.J., and López, J. (Eds.), Sociedad Española de Geomorfología, Monografía 4, Madrid, 163–174.
- Ginés, J., Fornós, J.J., Trias, M., Ginés, A., and Santandreu, G. (2007) Els fenòmens endocàrstics de la zona de Ca n'Olesa: la Cova de s'Ònix i altres cavitats veïnes (Manacor, Mallorca). *Endins*, **31**, 5–30.
- Ginés, J., Ginés, A., Fornós, J.J., Gràcia, F., and Merino, A. (2008) Noves observacions sobre l'espeleogènesi en el Migjorn de Mallorca: els condicionants litològics en alguns grans sistemes subterranis litorals. *Endins*, **32**, 49–79.
- Gràcia, F., Watkinson, P., Monserrat, T., Clarke, O., and Landreth, R. (1997) Les coves de la zona de ses Partions-Portocolom (Felanitx, Mallorca). *Endins*, **21**: 5–36.
- Gràcia, F., Clamor, B., and Lavergne, J.J. (2000) Les coves de Cala Varques (Manacor, Mallorca). *Endins*, **23**, 41–57.
- Gràcia, F., Jaume, D., Ramis, D., Fornós, J.J., Bover, P., Clamor, B., Gual, M.A., and Vadell, M. (2003) Les coves de Cala Anguila (Manacor, Mallorca). II: La Cova Genovesa o Cova d'en Bessó. Espeleogènesi, geomorfologia, hidrologia, sedimentologia, fauna, paleontologia, arqueologia i conservació. *Endins*, **25**, 43–86.
- Gràcia, F., Clamor, B., Jaume, D., Fornós, J.J., Uriz, M.J., Martín, D., Gil, J., Gràcia, P., Febrer, M., and Pons, G. (2005) La Cova des Coll (Felanitx, Mallorca): espeleogènesi, geomorfologia, hidrologia, sedimentologia, fauna i conservació. *Endins*, **27**: 141–186.
- Gràcia, F., Clamor, B., Fornós, J.J., Jaume, D., and Febrer, M. (2006) El sistema Pirata - Pont - Piqueta (Manacor, Mallorca): geomorfologia, espeleogènesi, hidrologia, sedimentologia i fauna. *Endins*, **29**, 25–64.
- Gràcia, F., Fornós, J.J., Clamor, B., Febrer, M., and Gamundí, P. (2007) La Cova de sa Gleda I. Sector Clàssic, Sector de Ponent i Sector Cinc-Cents (Manacor, Mallorca): geomorfologia, espeleogènesi, sedimentologia i hidrologia. *Endins*, **31**, 43–96.
- Maheu, J. (1912) Exploration et flore souterraine des cavernes de Catalogne et des Iles Baléares. *Spelunca*, **8:67-68**, 1–108.
- Martel, E.A. (1896) Sous Terre. Cueva del Drach, a Majorque. *Ann. Club Alpin Franc.*, **23**, 1–32.
- Merino, A., Mulet, A., Mulet, G., Croix, A., and Gràcia, F. (2008) La Cova des Pas de Vallgornera (Llucmajor, Mallorca): Alcanza los 55 kilómetros de desarrollo topográfico. *Endins*, **32**, 33–42.

CORROSION PATTERNS RELATED TO METEORIC-MARINE MIXING ZONE IN COASTAL CAVE SYSTEMS OF MALLORCA ISLAND (WESTERN MEDITERRANEAN)

FRANCESCA GRACIA^{1,2}, JOAN J. FORNÓS¹, and ANTONI MERINO^{1,2}

¹ *Departament de Ciències de la Terra, Universitat de les Illes Balears, Spain*

² *Federació Balear d'Espeleologia, C/ Margarida Xirgú, 16. 07011 Palma de Mallorca, Spain*

The genesis of the caves in the Migjorn area of Mallorca, located within Upper Miocene limestones, are related to the geochemical mechanisms derived from mixing processes between fresh meteoric water and sea water (coastal mixing zone). These littoral caves show stratified water longitudinal profiles that show layers of different salinity. These changes from lesser to greater salinity along the water column occur within the transition or mixing zone (haloclines). Corrosion morphologies generated within the mixing zone are very common in the studied caves.

Analysis of the cave morphology is crucial to understand the littoral endokarst's genesis and its evolution. Difficulties in the classification of the corrosion patterns into a specific typology, due to a juxtaposition of different types, with intermediate features and the differences in the intensity scale of dissolution is one of the main goals to overcome. Besides, the morphological changes in measurements introduce an increasing difficulty of classification.

In this paper, several cave morphologies are described and classified into megaforms (organization of endokarstic networks), macroforms (corrosion patterns from hectometric to decametric order), mesoforms (corrosion patterns from decametric to metric order), and microforms (corrosion patterns from metric to centimetric order).

1. Introduction

Littoral karst, as a global concept, corresponds to a highly active morphogenetic environment, where the coastal dynamics can greatly affect the karst evolution (Fig. 1). The result evokes either erosive or sedimentary processes that are greatly influenced by the complex Pleistocene history of quaternary glacioeustatic sea level oscillations (Ginés, 2000). The size of the littoral strip depends on the coastal morphology and dynamics, its relation to hydrological features of mixing zones (Hanshaw and Back, 1979), in which important speleogenetic and geochemical processes occur (Myroie and Carew, 1990), or the tidal effects on the phreatic level (Guilcher, 1998). In this sense, the meaning of littoral or marine karst based exclusively on surface microshaping (littoral or coastal karren) is avoided, as it is necessary to widen its notion to include the assemblage of conduits, galleries or chambers in whose formation the marine influence is involved, as defined in Ford and Williams (2007), for example, solution caves in the coastal mixing zone. In the present paper we describe corrosion morphologies generated by dissolution mechanisms related to the coastal mixing zone in three caves located (Fig. 1) in the south and southeast coasts (the Migjorn area) of the

island of Mallorca (Western Mediterranean).

2. Hydrology

In the cases illustrated here, the genesis of the caves, located within the Upper Miocene calcarenites, are related to the complex mechanisms derived from mixing processes between fresh meteoric water and sea water (coastal mixing zone). The waters within the littoral caves in the Migjorn area of Mallorca are stratified at all measured sites along a longitudinal profile (Fig. 2). that presents up to five well-marked stratification layers of different salinity (Gràcia et al., 2007). Because of difference in density, these layers are laid in order from the lowest to the highest salinity level. The changes from lesser to greater salinity along the water column occur within the transition zone (mixing) called haloclines or picnoclines.

These mixing zones in the calm underground environments remain quite stable over time. When subtle changes occur, centi-decimetric slight oscillations are determined by the weak tidal oscillations of the Western Mediterranean, barometric fluctuations, and the contribution of surface meteoric waters. At the same time, the water temperature

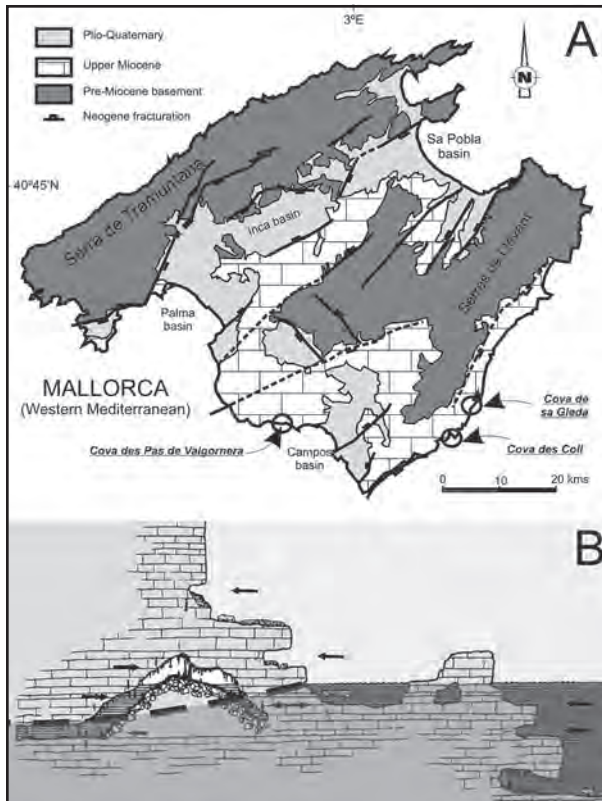

Figure 1: Location of studied caves (A) and representative profile coastal sketch (B) of the Migjorn area (Mallorca Island, W-Mediterranean). Arrows indicate past sea levels.

remains stable along the column (between 18 and 20° C). Significant changes only take place (a variation of 5° C on average) in the first meters in conjunction with seasonal variations that occur in the vast majority of caves with wide entrances and affecting only the closest underground lakes to those entrances.

3. Speleogenesis

Littoral karstification, particularly on many carbonate islands is simplified to the action of solutional processes in the mixing zone between fresh meteoric water and sea water, which quite often takes place in geologically young materials with a high primary porosity. The existence of this significant porosity makes secondary the role played by the structural guidelines in their evolution.

Other elements are involved in the speleogenetic control of the littoral caves. The case examined here is linked to the solutional processes in the mixing zone affecting the Migjorn area of Mallorca, but the epigenic karstification caused by the drainage of meteoric precipitation must be taken into account. Furthermore, a likely basal hypogenic recharge (Ginés et al., 2008) related to geothermal anomalies is being studied. All of these factors are controlled

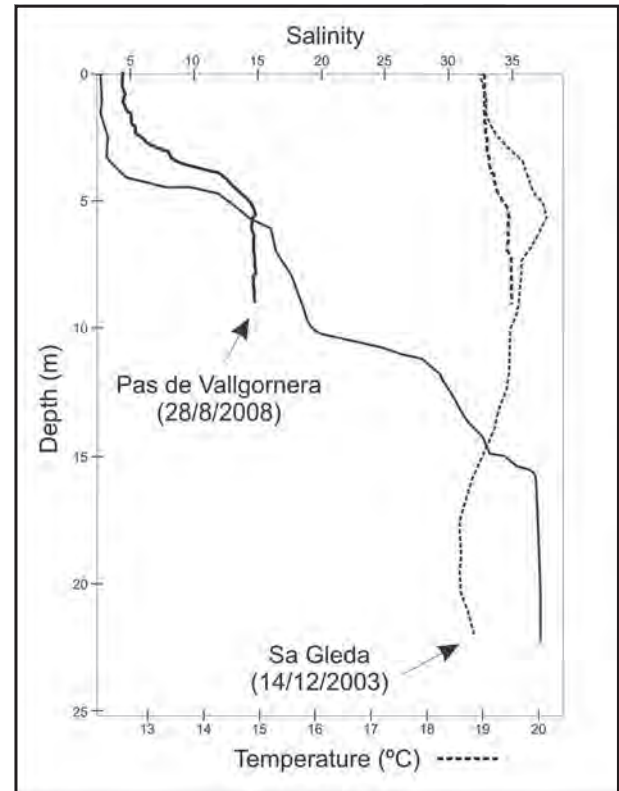

Figure 2: Characteristic temperature and salinity profiles obtained in the brackish water pools located in karstic cavities (Cova des Pas de Vallgornera and Cova de sa Gleda) of the south-eastern area of Mallorca.

by the calcarenitic lithology that shows abundant vertical and horizontal changes of facies, provoking fundamental variations in the hydrological parameters, such as permeability and porosity. In this sense, the distribution of big chambers and galleries as it relates to the presence of reef front facies must be highlighted. Those facies show a larger primary porosity and at the same time a larger mineralogical solubility of corals, easing the hydrological processes and dissolution.

4. Corrosion morphologies

The corrosion patterns described here are the result of corrosion mechanisms linked to the mixing zone that affects limestone (Gràcia et al., 2005). Study of these primary formations is crucial to understand the littoral endokarst's genesis and its evolution.

Difficulties classifying the corrosion patterns into a specific typology, due to a juxtaposition of different types, with intermediate features and the differences in the intensity scale of dissolution is one of the main goals to overcome. Moreover, the variation in size of these morphologies means an increase in the difficulty for their classification. Hence,

some of the morphologies described in this paper can be classed in more than one category.

Next, some of the most important patterns present in the Mallorcan littoral karst are listed, either for their abundance and/or volumetric magnitude, or for their significance in the

description of the processes that have caused them.

The typical features generated by corrosion in the mixing zone that can be classified as megaforms are close to those of the ramiform cave, where structural components tend to be predominant or to the spongiform caves highlighted by

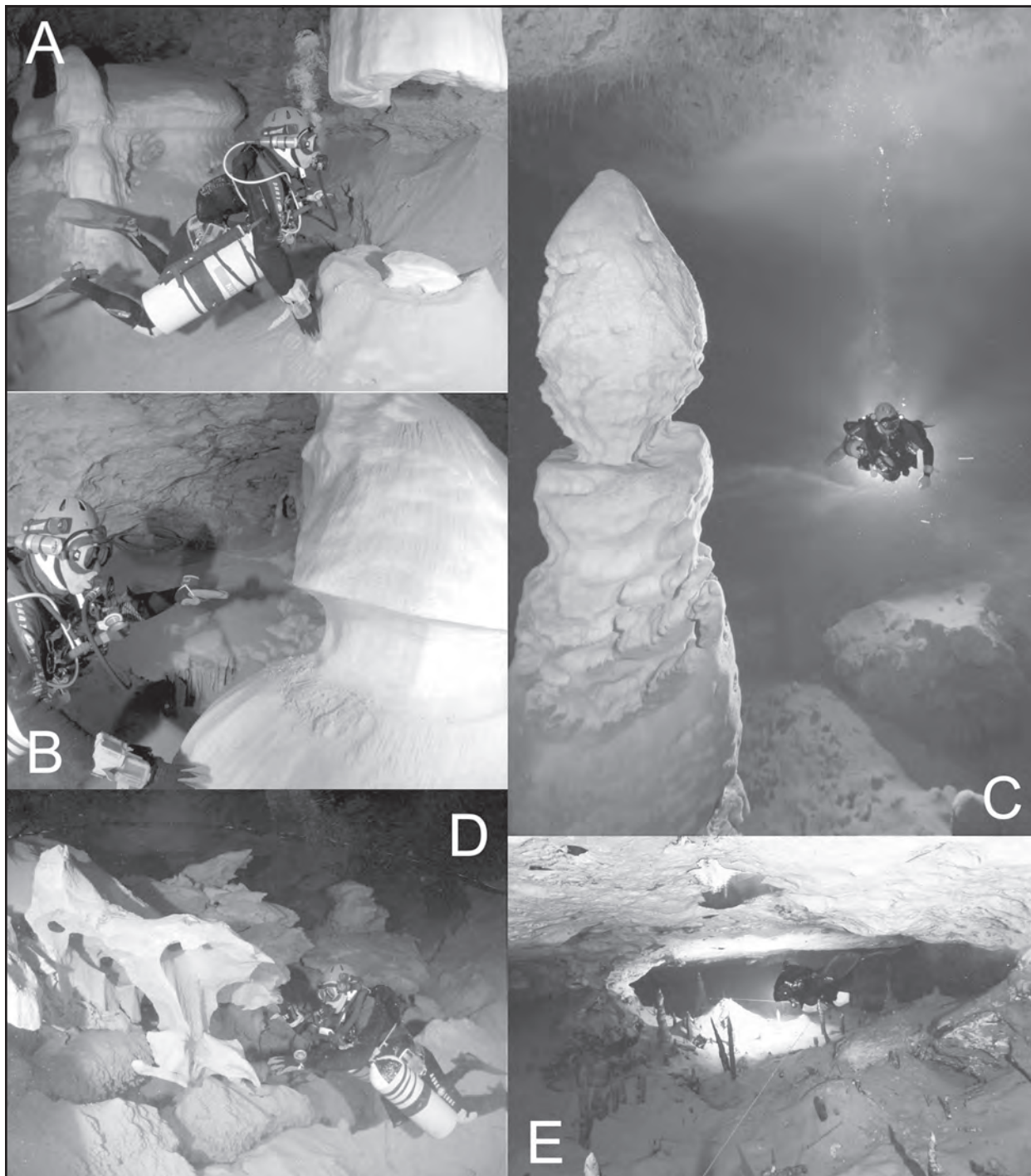

Figure 3: Several examples of corrosion morphologies (macro- mesoforms) related to the coastal mixing zone from Cova de sa Gleda (eastern Mallorca): (A) column sectioned by water dissolution; (B) notch; (C) column affected by an important narrowing caused by the dissolution in the mixing zone; (D) spongework morphologies; and (E) phreatic gallery with elliptical section.

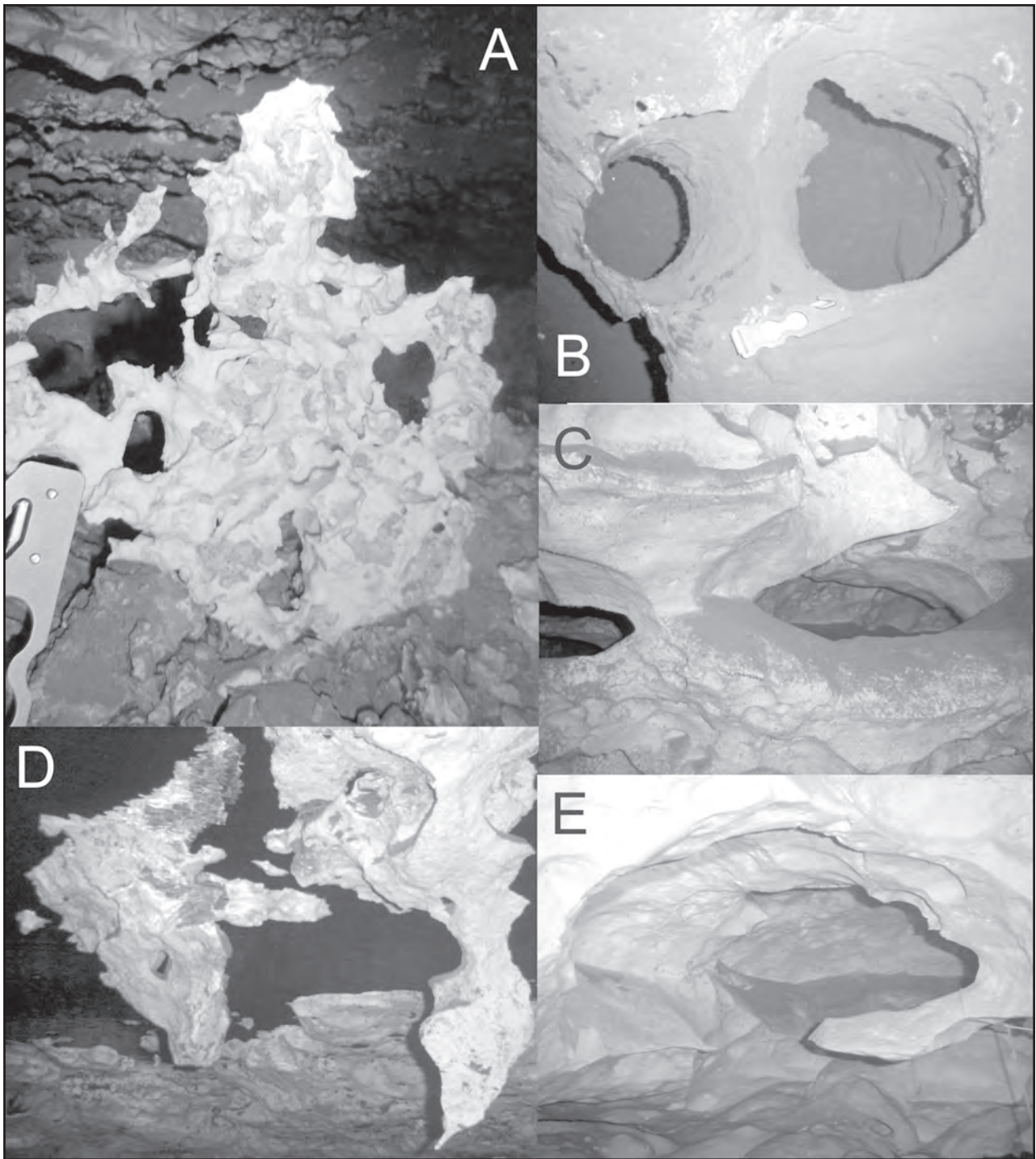

Figure 4: Several examples of corrosion morphologies (microforms) related to the coastal mixing zone from Cova des Coll (eastern Mallorca): (A) spongework; (B) arches; (C) wall pockets; (D) rock pendants and (E) rock jags.

the variation in facies characteristics (both mineralogy and texture). Within the macroforms (Fig. 3), phreatic networks of tectonic or stratigraphic origin, tubular passages and phreatic chambers have been identified. The mesoforms (Fig. 3) where phreatic and globular chambers can also include rock spans, rock pillars, bridges, spongeworks, corrosion notches and solution facets among others. Finally, within the microforms (Fig. 4) spongeworks can be once again

identified as well as arches, rock pendants, cers, rocky jags, subdued pockets, cupolas or bellholes, wall pockets, ceiling pockets, floor pockets, wall niches, rings and rock combs.

5. Conclusions

The principal characteristic which highlights the geomorphology of the coastal zone subaerial caves in the Migjorn area of Mallorca is the large abundance of corrosion

morphologies due to the corrosive effects associated with mixed waters. Throughout the caves different and varied types of these morphologies can be found.

We have catalogued these morphologies by form. The list of identified patterns (morphologies) includes: megaforms (organization of endokarstic networks), macroforms (corrosion patterns from hectometric to decametric order), mesoforms (corrosion patterns from decametric to metric order), microforms (corrosion patterns from metric to centimetric order). Some of these morphologies can be simultaneously found in two different categories: Megaforms: ramiform caves, spongiforms caves; Macroforms: phreatic networks, tubular passages, globular halls; Mesoforms: phreatic chambers, globular chambers; seminal conduits, rock spans, rock pillars, bridges, spongeworks, corrosion notches, solution facets; Microforms: spongeworks, arches, rock pendants, pinnacles (cers), rocky jags, subdued pockets, cupolas or bellholes, wall pockets, ceiling pockets, floor pockets, wall niches, rings, rock combs.

Acknowledgements

This research was supported by a project CGL2006-11242-C03-01/BTE of the *Ministerio de Ciencia e Innovación* – FEDER. Underwater tasks have partially been funded thanks to the *Fundació "SA NOSTRA", Caixa de Balears*, within the announcements of grants for Biodiversity Conservation Projects 2007 and 2008. We are grateful to the following colleagues for their contribution during the field works: Bernat Clamor, Pere Gamundí y Mateu Febrer.

References

- Ford, D.C. and Williams, P.W. (2007) *Karst hydrogeology and geomorphology*. John Wiley & Sons Ltd. 562 pp. Chichester, UK.
- Ginés, J. (2000) *El karst litoral en el levante de Mallorca: una aproximación al conocimiento de su morfogénesis y cronología*. Tesis Doctoral. Departament de Ciències de la Terra, Universitat de les Illes Balears. 595 pp + 29 lam.
- Ginés, J., Ginés, A., Fornós, J.J., Gràcia, F., and Merino, A. (2008) Noves observacions sobre l'espeleogènesi en el Migjorn de Mallorca: els condicionants litològics en alguns grans sistemes subterranis litorals. *Endins*, **32**, 49–80.
- Gràcia, F.; Clamor, B.; Jaume, D.; Fornós, J.J.; Uriz, M.J.; Martín, D.; Gil, J.; Gracia, P.; Febrer, M. & Pons, G.X. (2005) La Cova des Coll (Felanitx, Mallorca): espeleogènesi, geomorfologia, hidrologia, sedimentologia, fauna i conservació. *Endins*, **27**, 141–186.
- Gràcia, F.; Fornós, J.J.; Clamor, B.; Febrer, M. and Gamundí, P. (2007) La Cova de sa Gleda I. Sector Clàssic, Sector de Ponent i Sector Cinc-cents (Manacor, Mallorca): geomorfologia, espeleogènesi, sedimentologia i hidrologia. *Endins*, **31**, 43–96.
- Guilcher, A. (1988) *Coral Reef Geomorphology*. John Wiley & Sons Ltd. 228 pp. Chichester, UK.
- Hanshaw, B.B. and Back, W. (1979) Major geochemical processes in the evolution of carbonate-aquifer system. *Journal of Hydrology*, **43**, 287–312.
- Mylroie, J.E. and Carew, J.L. (1990) The flank margin model for dissolution cave development in carbonate platforms. *Earth Surface Processes and Landforms*, **15**: 413–424.

ENVIRONMENTAL FEATURES, COPEPOD TAXONOMIC DIVERSITY, AND DISTRIBUTION PATTERNS IN COASTAL CAVES ON MALLORCA ISLAND, SPAIN

S. IEPURE¹, A. GINES², F. FIERS³

¹ Institutul de Speologie "Emil Racoviță", Cluj Department, Clinicilor 400006, Cluj, Romania

² Àrea d'Ecologia, Departament de Biologia, Universitat de les Illes Balears, Crtra. de Valldemossa, km 7.5, 07122-Palma de Mallorca, Spain

³ Royal Belgian Institute of Natural Sciences, Vautierstraat 29, B-1000 Brussels, Belgium

Abstract

Coastal caves have drawn much attention since the high diversity of crustaceans thriving in this habitat became known in the second half of the 20th century. The particular sites were marine and freshwater conditions intermix, and which currently are referred to as anchihaline habitats, embraces several endemics, often considered as relicts of a Tethyan fauna. Two hypotheses on the origin of this characteristic fauna have been formulated: the "deep sea hypothesis" with immigrants evolved from deep sea ancestors; and the "shallow water hypothesis" that support a shallow, coastal waters origin for most anchihaline colonizers.

The highest taxonomic diversity of subterranean copepods is found in coastal caves, and probably results from the variety of habitat types (brackish and freshwater pools, and anchihaline pools with fluctuating salinity) present and the recruitment of elements with marine or freshwater roots. The proportion, however, of species with different ecological preferences in relation with habitat types has been rarely investigated for coastal caves. We compare the frequency and taxonomic diversity of the copepod community in the vadose (low salinity) and phreatic anchihaline habitats in four caves on Mallorca Island. (Balearic Isles, Spain).

A high diversity of cyclopinids, cyclopids and harpacticoids has been found in habitats with a salinity of 1.63-7, whilst in freshwater pools only harpacticoids are reported. The high species richness in anchihaline pools appears to result of addition of taxa and not of replacement. The small (less than 10 km) and large scale (of the whole island) pattern of species distribution was assessed to establish the potential role of dispersion in the copepods assemblages. Similarities of obligate stygobiont cyclopids with those listed in *Stygofauna Mundii* for 23 Mediterranean bioregions have been further calculated.

Bray Curtis similarity and multi-dimensional scaling shows close affinities of the Mallorca assemblages with Sardinia and southern Italy, rather than with the Iberian Peninsula. The similarities are primarily based on Mediterranean taxa of marine origin (i.e. *Halicyclops rotundipes* and *H. troglodytes*) and secondly on widespread lineages of obligate subterranean freshwater cyclopids, i.e. *Diacyclops clandestinus*. Data related to ecology, taxonomic diversity and biogeography of copepods in general and of cyclopids in particular are informative in establishing the origin of taxa from coastal habitats of the island.

COASTAL KARST OF CAGUANES NATIONAL PARK, SANCTI SPIRITUS, CUBA

PATRICIA KAMBESIS¹, PAUL BURGER², MIKE LACE³, JOEL DESPAIN⁴

¹Western Kentucky University, 1906 College Heights Blvd, Bowling Green, KY 42127

²1407 Bryan Circle, Carlsbad, NM 88220

³313 ½ Main Street, West Branch, IA 52358

⁴41170 Oakridge Drive, Three Rivers, CA 93271 USA

Caguanes National Park, in Yaguajay Municipality, Sancti Spiritus Province on the Atlantic coast of Cuba, is located on the Caguanes peninsula (Cayo Caguanes) and includes the Guayaberas Swamps and ten small cays that extend into the Bay of Buena Vista. The coastal landscape of the park is characterized by caves, sinkhole collapses, and arches that open to the Atlantic Ocean. The caves were first described by the late Dr Antonio Nuñez Jimenez who recognized them as having a different speleogenetic origin than both sea caves and fluvio-karst systems typical of the island.

The caves of Caguanes are formed in Miocene-aged carbonates that display a structural dip of 20 degrees to the south. Cave passage trends appear to be structurally controlled by joints and overall passage morphology is ramiform. Recent detailed subterranean and surface mapping, geologic observation, and morphometric analysis have identified three types of caves in the Caguanes area: sea caves, flank margin caves, and banana holes. Sea caves form by non-dissolution processes such as wave action or bioerosion on a coastline. Flank margin caves, which are of hypogene origin, also occur on or near a paleoshoreline but form as result of fresh-water/saltwater mixing at the discharging margin of a fresh-water lens. Banana holes are epigenetic in origin since they form in connection with the surface from autogenic recharge percolating through the vadose zone.

The distinction between sea caves and flank margin caves is critical because though both types are indicators of sea-level position through time, each provides different information with respect to denudation rates and only flank margin caves and banana holes provide information about island hydrology. These factors are important considerations in paleoclimate interpretations and in understanding coastal evolution and paleohydrology.

1. Introduction

The caves of Caguanes National Park were first described and documented by Dr. Antonio Nuñez Jimenez, Cuba's preeminent geographer and karst scientist. He visited the Caguanes peninsula in the sixties and, based on his surveys and geologic observations, recognized that the caves of Caguanes had a different speleogenetic origin than other caves that he studied in Cuba (Nuñez Jimenez, 1967). He attributed their ramiform morphology to a phreatic origin related to a fresh-water lens. He observed that the caves had horizontal profiles that developed at distinct elevations, and speculated were the result of sea-level changes related to glacial eustasy (Nuñez Jimenez, 1970). He even noted that microbial activity could enhance the dissolution of such caves. Though he did not have a speleogenetic model for the caves of the Caguanes area, he classified them in a special category called "Tipo Caguanes". Nuñez Jimenez was probably the first karst scientist to recognize and document a type of cave whose speleogenesis is a function of a fresh-

water lens and changes in sea level; what is today classified as a flank margin cave.

Recent field work at Cayo Caguanes identified three types of caves including sea caves, flank margin caves, and banana holes. The distinction between sea caves and flank margin caves is critical because though both types are indicators of sea-level position through time, each provides different information with respect to denudation rates and hydrology. Only the flank margin caves and banana holes mark the location of a fresh-water lens. These factors are important considerations in paleoclimate interpretations and in understanding coastal evolution and paleohydrology.

2. Geography and Geology

Caguanes National Park (area 204 km²) is located in Yaguajay Municipality, Sancti Spiritus Province on the Atlantic coast of Cuba (Fig. 1). The park consists of Cayo Caguanes and the surrounding Guayaberas swamps, and

ten islets called Cayos de Piedra that extend into the Bay of Buena Vista. The coastal landscape of the park is characterized by caves, sinkhole collapses, and arches that open to the Atlantic Ocean. The bedrock exposed at the surface displays the typical jagged and irregular karren characteristic of eogenetic rocks.

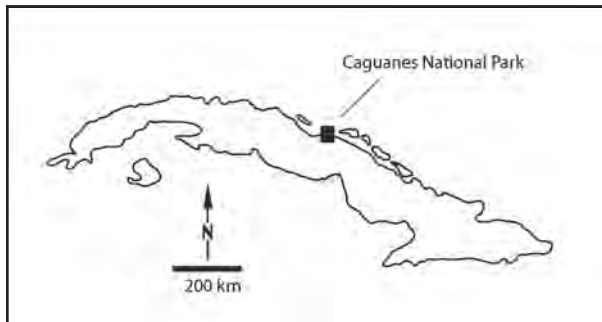

Figure 1: Location of Caguanes National Park, Sancti Spiritus, Cuba.

The focus of this study was Cayo Caguanes, a small peninsula (2 km²) surrounded by mangrove swamps on its south and east sides, a tidal lagoon to the northwest, and the Atlantic Ocean on its north-northeast side. The cayo is composed of two small hills with elevations of 29 and 27 meters above mean sea level (amsl) and are bisected by a lower elevation saddle at 10 meters amsl. There are no surface streams on Cayo Caguanes and all drainage is autogenic.

The Caguanes area is located in the tectonic Cayo Coco zone of northern Cuba, south of the Old Bahamas Channel (Lewis and Draper, 1990). This zone is made up of a continuous sequence (more than 5,000 meters) of primarily carbonate rocks dating from the middle Mesozoic to middle Cenozoic. Rotation along east-west trending normal faults caused large structural blocks to tilt southward. Parts of these blocks had become emergent by late Miocene and fully emergent by the Pliocene (Lewis and Draper, 1990).

The strata of the Caguanes area are middle Miocene in age (Nuñez Jimenez 1970) composed of cross bedded carbonate grainstones consistent with deposition on a shallow, high-energy shelf (Scholle et al., 1983). The deposits are interpreted to be a mix of shallow-water deposits with some sediments that represent deep-water channels similar to the Bahama Banks (Lewis and Draper, 1990). The bedrock exposed in the caves is composed of thick beds of cross-bedded carbonate grainstones and bedded limestones that exhibit a strong northward depositional dip. There are very few intact fossils which makes determination of exact age difficult. Geopetals, in the form of early cemented sediment

fill in vugs indicate that the main block in Caguanes tilted to the south prior to the onset of cave development.

3. Field Investigations

Preliminary geologic work was done in the early sixties (Nuñez Jimenez, 1967) and since that time research has focused on paleontology, biology and archeology (Nuñez Jimenez, 1970; Emperador et al, 2007). As a result of this previous field work, 35 caves have been documented in Caguanes National Park. In 2007, a joint Cuban-American team working on Cayo Caguanes conducted an inventory and detailed survey of area caves, as well as doing geologic fieldwork in order to determine cave type and speleogenesis. Of particular interest from the detailed survey was the level of complexity of the cave walls and the ratio of area to perimeter as determined from finished maps. These measures have been used on other islands in the Caribbean to help determine cave type (Lace, 2008; Waterstrat, 2007). Thirteen caves were documented during the field work and a total of nine kilometers of cave passage surveyed. However, due to the morphology of the caves, the standard measure of surveyed length does not reflect the true dimensions of each cave (Myroie, 2007). Henceforth cave dimensions will be given in floor area.

4. Caves of Cayo Caguanes

The caves on Cayo Caguanes are situated either on the north coastline of the cayo or remain inland and landlocked due south of the coast.

A total of six caves were located on the coast with mapped floor areas from 73 m² to 488 m² and at elevations that ranged from sea level to seven meters above. Four of the caves did display cusped wall features indicative of phreatic development. All of the caves showed some degree of denudation either by littoral action or by surface collapse.

The landlocked caves (seven total) had mapped floor areas ranging from 1100 m² to 35,500 m². The caves were located in two clusters in association with the two hills that make up Cayo Caguanes (Fig. 2). The hills are separated by a lower elevation saddle under which there is no known cave development. The caves under the north hill are aligned parallel to the north coast. The caves under the south hill also display a parallel alignment but to the Guayaberas swamps.

Chambers and passages of the different caves within both clusters lie in close proximity, but passages end in blank walls so it is unlikely that they at one time connected. Passage dimensions within individual caves can range from 10 to

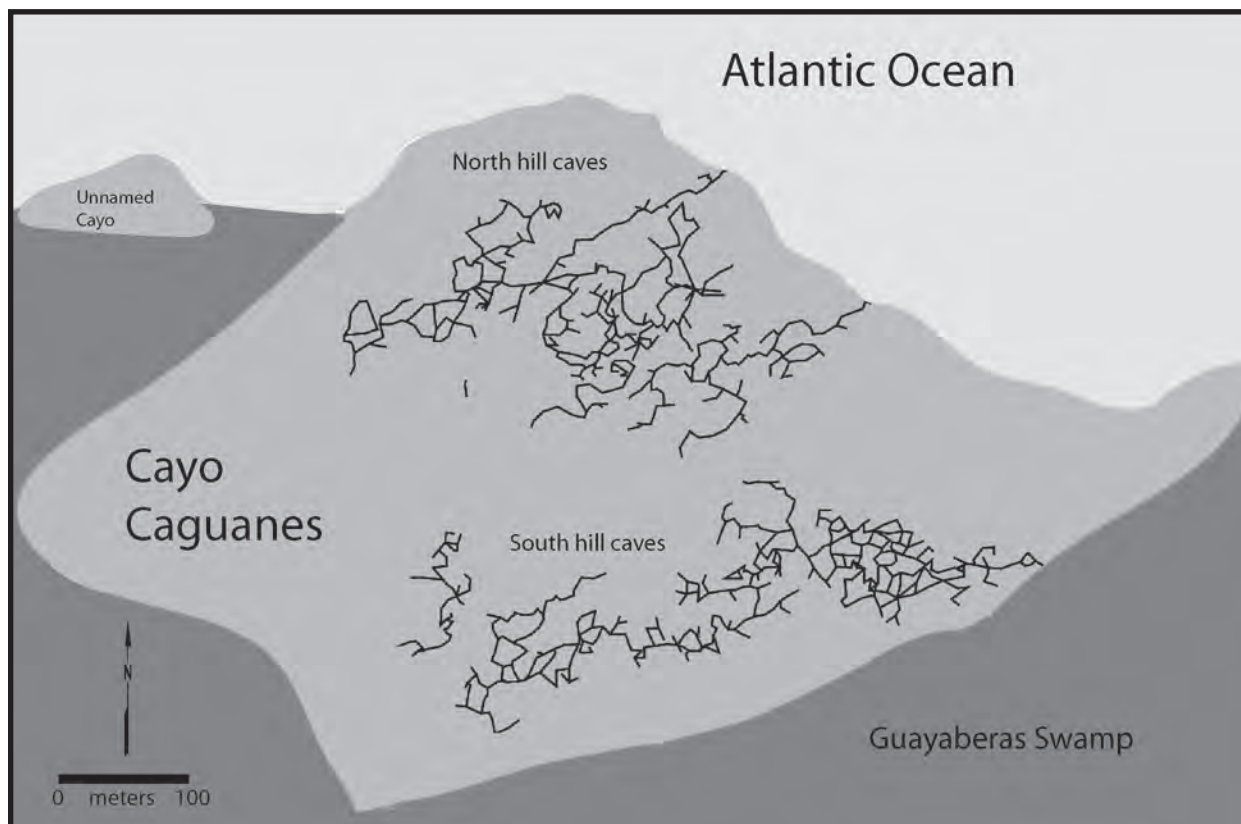

Figure 2: Simplified map of Cayo Caguanes showing current location of flank margin caves with respect to the north and south hills of the cayo.

25 meters in width and ceiling heights up to 10 meters. The profiles of the caves are predominantly horizontal and indicate development that cross cuts both the northward depositional dip and the southward structural dip. The collective profiles show that passage development occurs on five distinct tiers.

The caves are breached by surface collapse that forms many skylights and all of the cave entrances. Although the caves seemed to have developed on distinct structural trends, they are ramiform in overall shape and are comprised of large oval chambers and interconnecting passages with wall perimeters displaying a complex cusped morphology. Two of the caves each have a passage leading to small entrances on the north coast. In general, none of these caves show any evidence of fluvial action or associated sediments though the passages that lead to the ocean contain shallow, water-cut channels. Extensive massive speleothem development is common in all of the land-locked caves.

One of the inland caves was a collapsed phreatic chamber with a bell-shaped profile. The cave is floored with sediment and had a very small stream that flowed across the bottom disappearing into impassible clefts in the wall. The stream

post-dates the development of the cave and is likely autogenic recharge from the epikarst.

5. Cave Classification

Recent studies on coastal caves have demonstrated that morphometric measurements from detailed cave maps can augment and validate field observations for determining cave type (Lace, 2008; Waterstrat, 2007). The morphometric quantification of speleogenetic type is based on the ratio of cave footprint perimeter (P) vs. floor area measurements (A). Flank margin caves will have larger A/P ratios than sea caves of comparable size because of their complex cusped perimeter and resulting larger area value versus simple wall perimeter and smaller area of sea caves.

Caves occurring on the north coast of the cayo were morphometrically analysed by plotting area-perimeter ratios, which supported the field observation that two of the caves are sea caves (Fig. 3) and the remaining four are flank margin caves showing varying degrees of denudation.

Detailed maps for most of the landlocked caves have not yet been completed, however the character and layout of the caves in the context of their geologic setting make their

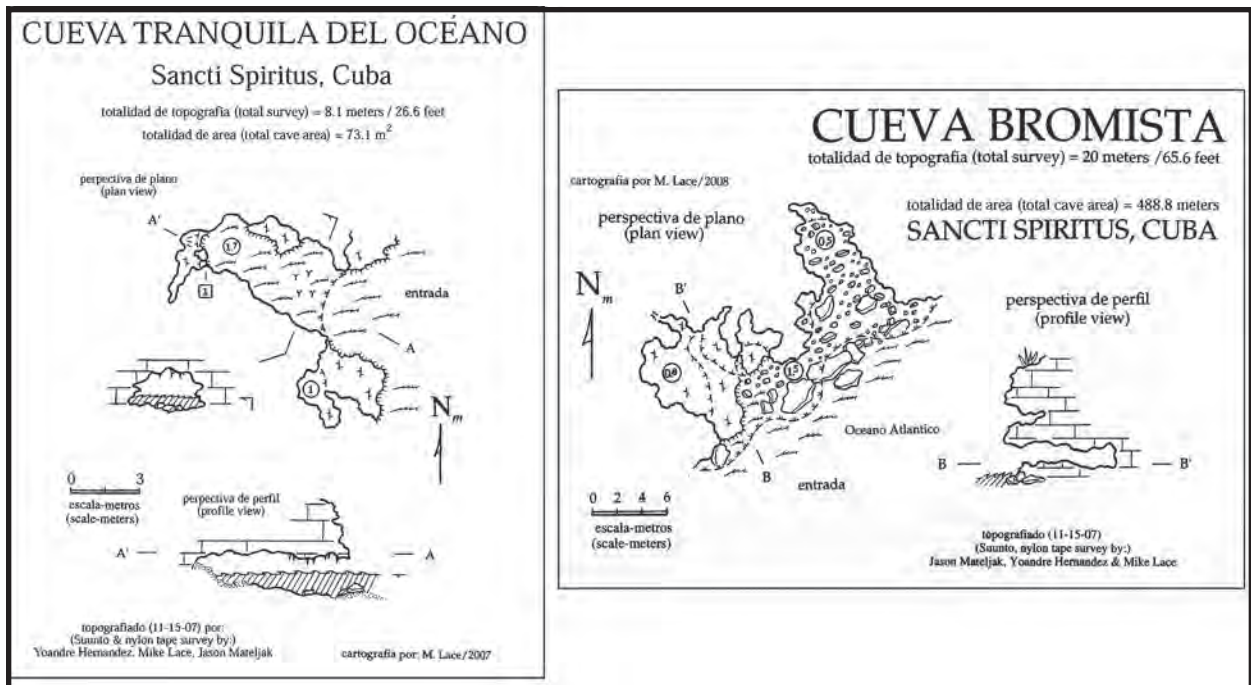

Figure 3: Typical sea caves from the north coast of Cayo Caguanes.

classification as flank margin caves definitive. All of the larger landlocked caves (mapped floor area >3000 m²) are composed of distinct sets of wide, oval-shaped chambers and interconnecting passages containing remnant bedrock pillars (Fig. 4). The wall perimeter of all of the caves displays the complex cusped morphology of caves developed from mixing zone dissolution, typical of flank margin caves. Geographically, individual cave passages within each of the two clusters are separated in places by a few meters, but end in blank bedrock walls.

There is an absence of fluvial deposits or turbulent flow features in all of the landlocked caves. This is an obvious reflection of the fact that there are no surface streams on Cayo Caguanes and that meteoric recharge is autogenic. The shallow channels observed near the entrances of the two caves that open to the ocean are most likely a result of receding storm surges that can easily be flushed into the entrances rather than from fluvial conditions.

Extensive speleothem development is evident in all of the landlocked caves, with many of them attaining significant size and distribution. Though this is not a defining characteristic of flank margin caves it does indicate that speleothem deposition occurred within a closed cave environment. Flank margin caves form without entrances and are only exposed to the surface from surface collapse or littoral denudation. On Cayo Caguanes, the entrances and skylights within all of the caves are a result of surface

collapse occurring mostly at joint intersections.

One small vertical cave may be a banana hole because of phreatic features observed during the survey (Fig. 5). Banana holes form by dissolution at the top of the fresh-water lens by mixing of lens water with vadose water (Harris et al., 1995). However, only one such cave was documented during the field work because of exploration bias and lack of time.

6. Speleogenesis at Cayo Caguanes

The geologic evolution of the north coast of Cuba has been influenced by rotation along east-west trending normal faults, which caused large structural blocks to tilt southward (Fig. 6). Parts of these blocks became emergent by Late Miocene and fully emergent by the Pliocene (Lewis and Draper, 1990). Subaerial karst processes in the Caguanes area would have become active once the blocks were emergent and exposed to the effects of meteoric waters.

According to the Carbonate Island Karst Model (Myroie and Myroie, 2007), Cuba is a complex carbonate island. Although during high sea-level stands, Cayo Caguanes would have been isolated from the main island causing it to function as a simple carbonate island.

Meteoric water entering the emergent carbonate block of high porosity and permeability inherent to diagenetically immature rocks (Vacher and Myroie, 2002) would make a fresh-water lens thus setting the stage for flank margin cave

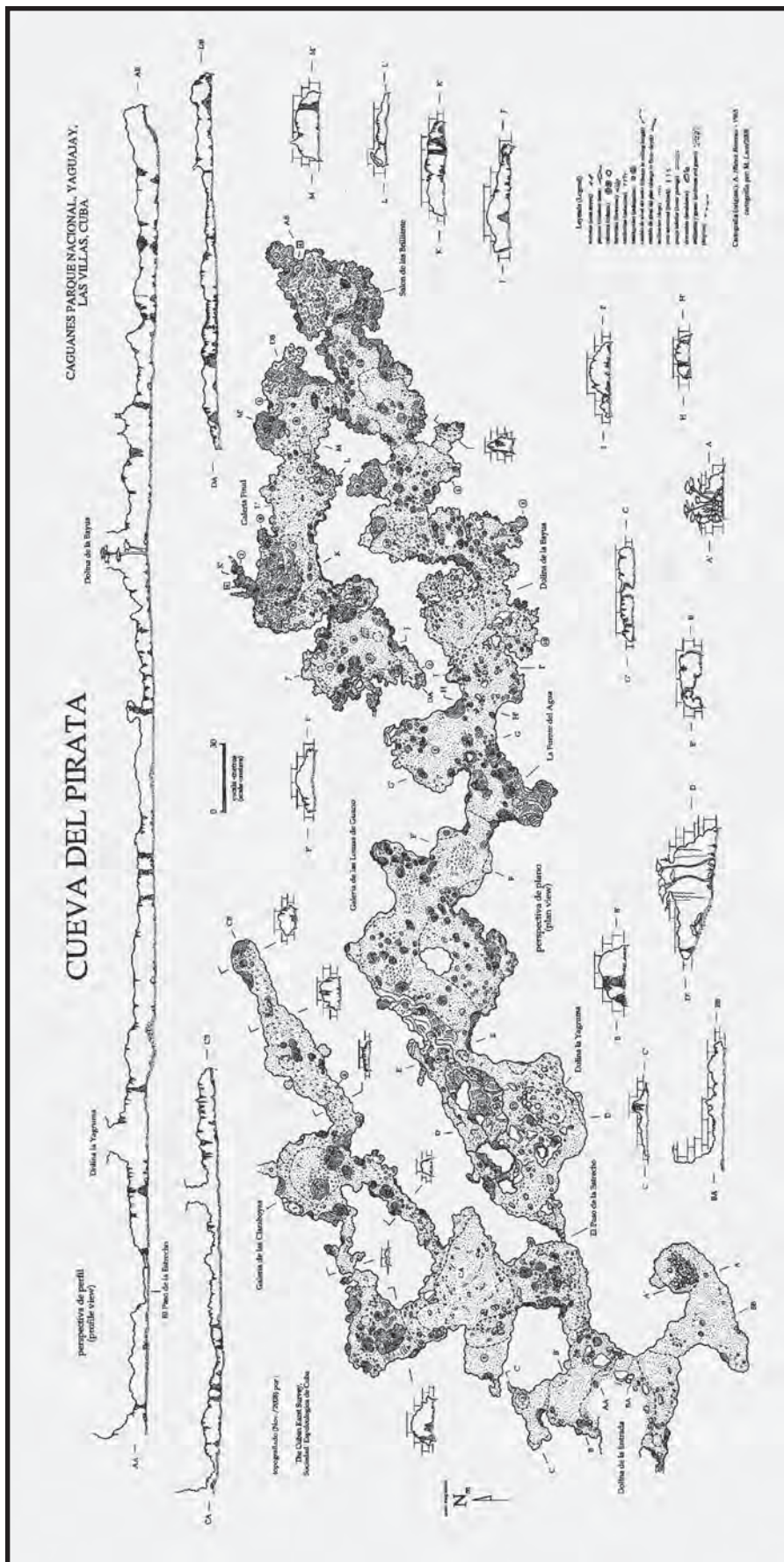

Figure 4: Typical flank margin cave on Cayo Caguanes.

development. Flank margin caves formed at the distal edge of the fresh-water lens and banana holes would have developed at the top of the fresh-water lens. Joints trends related to the tectonic history of the carbonate blocks on the cays and along the coast provided additional avenues for the mixing of fresh water and sea water and may have influenced the joint-controlled nature of many of the cave passages.

Flank margin caves align parallel with paleoshorelines towards the distal edge of freshwater lenses. The caves under the north hill of Cayo Caguanes parallel the Atlantic coast. If Cayo Caguanes were surrounded with water as would be expected during a sea-level highstand, then the caves under the south hill would form parallel to the south front of the fresh-water lens and also with the south coast of the cayo. This may account for the two clusters of flank margin caves and their alignment.

Based on the discovery of Pleistocene-aged vertebrate fossils in the sediments of some of the area caves (Gonzalez and Bordon, 1970), the caves of Cayo Caguanes were fully developed by the Pleistocene. Tectonic information indicates that the tilted limestone blocks underling the area were emergent during the Pliocene (Lewis and Draper, 1990)

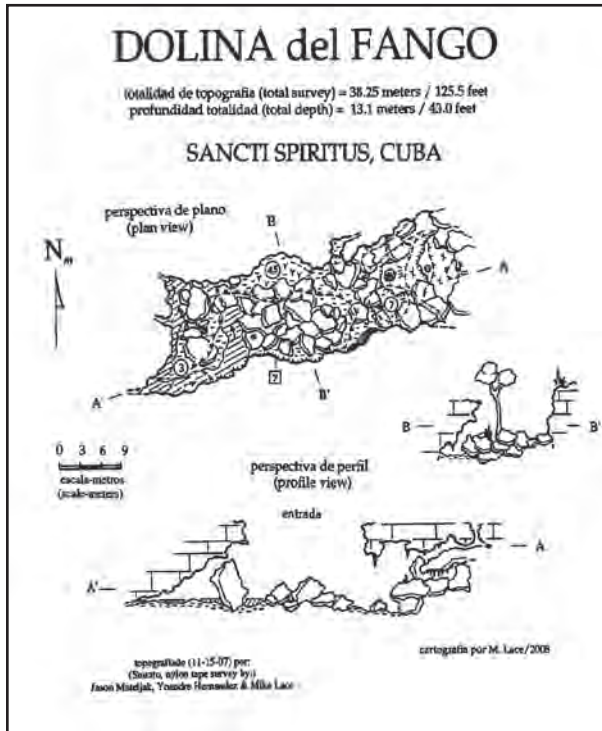

Figure 5: Banana hole on the north hill of Cayo Caguanes.

The occurrence of flank margin caves on Cayo Caguanes indicate stable periods of past sea-level highstands. The location of the cayo in a tectonically active zone may account for horizontal cave passage development at multiple elevations. The vertical extent of sea caves and flank margin caves indicate that tectonics and glacioeustasy influenced cave development in the Caguanes area.

7. Conclusions

Caguanes National Park is populated by caves formed from psuedokarstic and dissolutional karst processes. Sea caves, which are psuedokarstic, formed by wave action on the coastline. Flank margin caves are coastal hypogene caves that are the result of fresh-water/saltwater mixing at the discharging margin of a fresh-water lens. Banana holes are epigenetic in origin and form at the top of the fresh water lens in connection with the surface from autogenic recharge percolating through the vadose zone.

The topography of Cayo Caguagnes and the occurrence of flank margin caves indicate that past sea-level highstands separated the cayo from the Cuban coast and that the highstands were stable enough to allow cave development. The multiple tiers of horizontal passage development within the landlocked caves of the cayo are a function of sea-level fluctuations with stable highstands, and tectonic uplift. The discovery of Pleistocene vertebrate fossils within some of the larger flank margin caves indicate that the caves were fully

developed by the Pleistocene and possibly formed in the Pliocene. This makes Cayo Caguanes a coastal paleokarst.

The identification and occurrence of the different types of caves provides a means of understanding the evolution of the coastal karst and paleohydrology of the Caguanes coastline. Documentation of additional caves and karst features on adjacent cays, both littoral and landlocked, will likely

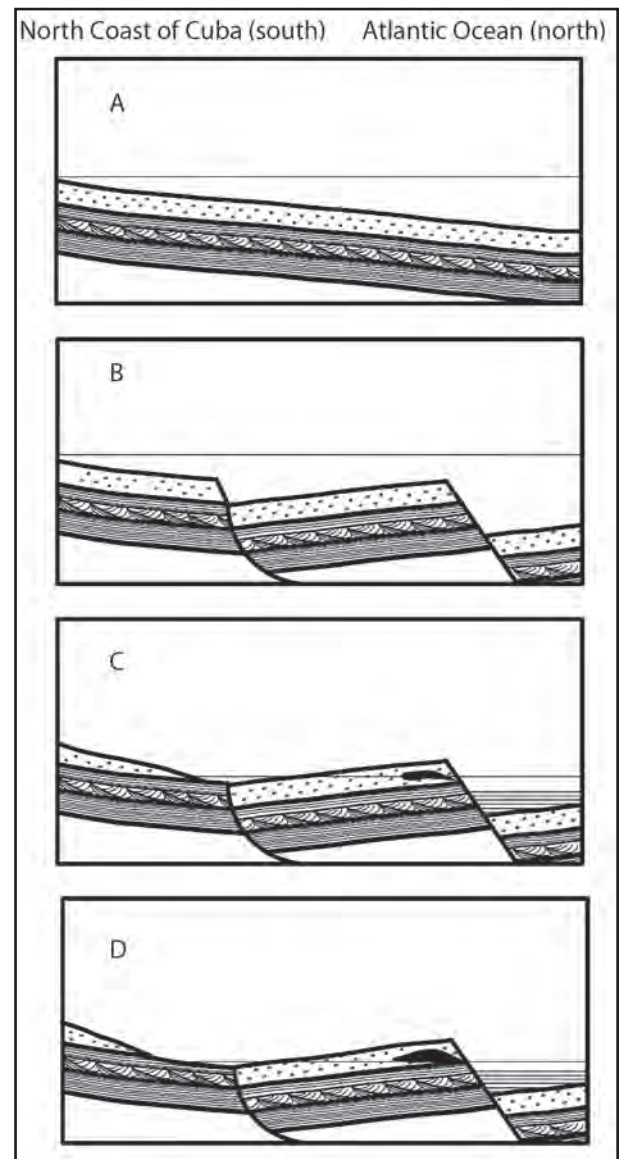

Figure 6: Tectonic evolution of the north coast of Cuba and the development of flank margin caves. A. Shallow, high energy shelf. B. Tectonics caused rotation along east-west trending normal faults resulting in the southward tilting of large structural blocks. C. The upper tips these blocks became emergent by the Pliocene exposing them to meteoric waters and the development of a fresh water lens and flank margin caves. D. Lowering of sea level drains the caves and exposes the surface of the blocks to denudation processes.

support a more comprehensive understanding of coastal karst development on the north coast of Cuba.

Acknowledgements

We would like to acknowledge Cyndie Walck of the Cuba Caves Project for organizing the field expeditions and acquiring research permits through the Office of Foreign Assets Control (OFAC), Hoffman Environmental Research Institute for research support, Grupo Sama for their partnership, and Sociedad Espeleológica de Cuba for hosting the 2007 research expedition in La Habana.

References

- EMPERADOR, R.A., 2007, Estudio preliminar del arte pareital de la region de Cuba, Cavernes, 2007 Spécial archéologie à Cuba.
- GONZÁLEZ, A.G., and BORDÓN, J. I., 1970, Sistema Subterráneo de Punta Judas, *Serie Espeleologica y Carsologica No. 30*, Simposium XXX Aniversario de la Sociedad Espeleologica de Cuba, 45 p.
- HARRIS, J. G., MYLROIE, J.E., and CAREW, J.L., 1995, Banana holes: Unique karst features of the Bahamas: *Carbonates and Evaporites*, v. 10, no. 2, p. 215-224.
- LACE, M. J., 2008, Coastal cave development in Puerto Rico: *Journal of Coastal Research*, v. 24, no. 2, p. 508-518.
- LEWIS, J.F. and DRAPER G., 1990, Geology and tectonic evolution of the northern Caribbean margin, in Dengo, G., and Case, J.E., eds., *The Caribbean region: Boulder, Colorado, Geological Society of America, The Geology of North America*, v. H.
- MYLROIE, J.E., and Carew, J.L., 1995, *Karst development on carbonate island in Unconformities in Carbonate Strata – Their recognition and the significance of associated porosity*, eds., Budd, D.A, Saller, A. H., Harris, P. M. AAPG Memoir 63, p. 55-76.
- MYLROIE, J.E., 2007, Cave surveys, cave size, and flank margin caves: *Compass and Tape*, v. 17, no. 4, p. 8-16.
- MYLROIE, J.E. and MYLROIE J. R., 2007, Development of the Carbonate Island Karst Model. *Journal of Cave and Karst Studies*, v. 69, p. 59-75.
- NUÑEZ JIMENEZ, A., 1967, Clasificación Genética de las Cuevas de Cuba, Academia de Ciencias de Cuba, Instituto de Geografía, La Habana 1967, 224 p.
- NUÑEZ JIMENEZ, A., 1970, Caguanes pictográfico, *Serie Espeleologica y Carsologica No. 16*, Simposium XXX Aniversario de la Sociedad Espeleologica de Cuba, 72 p.
- SCHOLLE, PA., BEBOUT, D.G., MOORE, C.H., 1983, Carbonate depositional environments: Tulsa, Oklahoma, *American Association of Geologists Memoir 33*.
- VACHER H.L. and MYLROIE J.E. 2002. Eogenetic karst from the perspective of an equivalent porous medium. *Carbonates and Evaporites* 17(2), p. 182-196.
- WATERSTRAT. W.J., 2007, Morphometric Differentiation Of Flank Margin Caves And Littoral, Or Sea Caves [Msc. thesis]: Mississippi State University, 201 p. <http://library.msstate.edu/etd/show.asp?etd=etd-04052007-150907>

COASTAL SPELEOGENESIS IN PUERTO RICO

MICHAEL J. LACE¹, PATRICIA N. KAMBESIS²¹*The Coastal Cave Survey, 313 1/2 West Main St., West Branch, IA 52358 USA, michael-lace@uiowa.edu*²*Proyecto Isla de Mona, 177 Hamilton Valley Rd., Cave City, KY 42127 USA, pnkambesis@juno.com*

Recent analysis of coastal cave resources in Puerto Rico has provided invaluable insights into the complex interaction of speleogenic processes in this tectonically-active coastal setting. Littoral erosion of Miocene-aged limestone and Quaternary carbonate eolianite exposures has produced numerous sea caves. Dissolution processes at the freshwater/saltwater interface, or the corrosive interaction of the distal “margin” of a freshwater lens on its enclosing coastal landform (i.e. the landmass perimeter or “flank”), has also produced examples of “flank margin” cave development. Analysis of overall cave structure within an inventory of over 80 shoreline features identified 17 flank margin caves with areal footprints (total cave areas) ranging from 20 to greater than 1414 square meters. Morphometric analysis was able to quantitatively distinguish intact or partially denuded flank margin structures from littoral structures based on their total cave areas and distinctive perimeter morphologies. In addition to these primary speleogenic processes, secondary modification of these caves by littoral and/or tectonic mechanisms has also produced a diverse array of shoreline features, including fissures and talus caves formed by progressive cliff retreat. Furthermore, flank margin caves were identified at multiple distinct elevations along the northern, Atlantic coast, ranging from 0 to 35 meters above current mean sea level. While tectonic overprinting complicates precise quantification of previous stillstands in this setting, the presence of flank margin caves at distinct elevations indicates the possibility of multiple past freshwater lenses of sufficient stability and duration to permit limited mixing zone dissolution. These results correlate the morphology of these unique shoreline structures with previous glacioeustatic sea level stands and underscore the importance of detailed examination of all coastal karst features within this and other complex carbonate island platforms.

1. Introduction

Karst studies in Puerto Rico have historically been focused on the expansive and complex fluvial karst systems of the island interior (Lugo et al., 2000; Miller, 2004). Early geologic fieldwork spanning the late 1940s and into the 1980s had included the examination of shoreline structures (Kaye, 1959; Monroe, 1976; Monroe, 1980) as well as cave resources on nearby Isla de Mona (Frank et al., 1998). Recently, a detailed examination of coastal cave resources in Puerto Rico revealed a diverse inventory of cave structures formed by littoral activity (sea caves) and previously undocumented examples of mixing zone speleogenesis, or “flank margin cave development” (Mylroie and Carew, 1990). Mechanisms of speleogenesis in eogenetic coastal karst areas (Mylroie and Carew, 2000; Mylroie and Mylroie, 2007; Vacher and Mylroie, 2002) are proving to be complex and varied from one carbonate platform to another (Gines and Gines, 2007; Kambesis et al., 2009; Smart et al., 2006). Determination of primary speleogenic processes in contemporary as well as paleoshoreline settings can be problematic as the interaction of multiple coastal processes can mask the speleogenic origins of these distinctive coastal features, often requiring detailed

examination of their morphology (Lace, 2008; Waterstrat, 2007). Digital 2D modeling of overall cave morphology (“morphometric analysis”), which utilizes spatial parameters such as total cave area and perimeter, has proven to be a robust method of quantitatively defining coastal cave structures, having been applied to various carbonate island platforms in the Marianas, the Greater Antilles, the Caroline Islands of the western Pacific (Mylroie et al., 2008), the Bahamas (Owen, 2007; Waterstrat, 2007), as well as in the peninsular coastlines of the Yucatan (Kelley et al., 2006) and the diagenetically mature coastal landforms of New Zealand (Mylroie and Mylroie, 2008) and the western coast of the United States (Waterstrat, 2007). This study examined overall coastal cave morphology, utilizing detailed cartographic representations and analytical methods capable of quantitatively delineating speleogenic origin. Furthermore, these methods were shown to be effective in defining the degree of secondary modification of coastal cave resources as a function of shoreline structure in Puerto Rico.

2. Methods

Primary mechanisms of speleogenesis at each coastal site were initially determined in the field by qualitative

identification of representative structural features characteristic of flank margin, tectonic or littoral cave development. Similarly, the approximate degree of cave denudation was initially determined by direct field observation. All caves were surveyed with Suunto compass, clinometer and nylon tape by teams of 1 to 3 surveyors over a six year period (2002 to 2008) and detailed maps generated, using standard cartographic techniques (Dasher, 1994). To complement qualitative, on-site speleogenic classification of cave structures, all cave maps were digitally scanned prior to morphometric image analysis - a 2D spatial geometric analytical technique used to quantitatively define cave morphologies. Utilizing NIH 1.62f [freely available software from the National Institutes of Health (NIH)], this study quantified total cave area and perimeter from each detailed cartographic representation. Therefore "cave area" was defined as the space encompassed by the dripline of the cave entrance and the interior passage walls while "cave perimeter" was defined as the sum of the internal perimeter length of the cave and its entrance dripline. In coastal karst, particularly for flank margin caves, total cave area and perimeter serve as more useful quantitative measures of defining cave structure than traditional expressions of total cave length, as shown within this data set and in studies within other island locales (Roth, 2004; Waterstrat, 2007). Cave denudation was measured as a ratio of the maximum entrance width (EW) and maximum internal passage width (IW), digitally determined from each cave map. Orthometric elevations of cave sites were obtained by surface survey wherever feasible, using standard instruments and methods as described above and expressed as elevations relative to mean low sea level (MLSL) using date and time-specific sea level data from NOAA gauging stations on the northern, western and southern Puerto Rican coastlines, respectively. General **stratigraphy of coastal cave sites was previously defined (Monroe, 1976).**

3. Results

3.1 Delineation of flank margin versus sea cave development by morphometric analysis.

Determination of primary mechanisms of coastal speleogenesis was first accomplished through direct field observation of hallmark representative morphologic features associated with littoral erosion (Fig. 1A), tectonics or flank margin speleogenesis (Fig. 1B). To complement field observations, analysis of cave structure using detailed maps generated from surveys at each cave site provided a quantitative measure of cave morphology and primary speleogenic process (Fig. 2). This examination of the coastal cave data set from Puerto Rico further supports the application of morphometric analysis in determining

the primary mechanism of speleogenesis of coastal caves in this complex carbonate island setting. In a plot of total cave area versus complex perimeter length of flank margin caves, a proportional increase in these spatial parameters (characteristic of flank margin speleogenesis) yields a linear trend as opposed to a non-linear trend within the sea cave data set (Fig. 3). Not surprisingly, as the size and perimeter complexity of flank margin caves increases, the morphometric delineation from sea cave structures becomes more effective. However, the influence of secondary speleogenic controls can also result in partial or near complete overprinting (e.g. subsequent littoral erosion) of the primary process of cave development, as illustrated in overprinted flank margin sites anomalously co-plotting with the sea cave data trend (Fig. 3, sites #38 and #64).

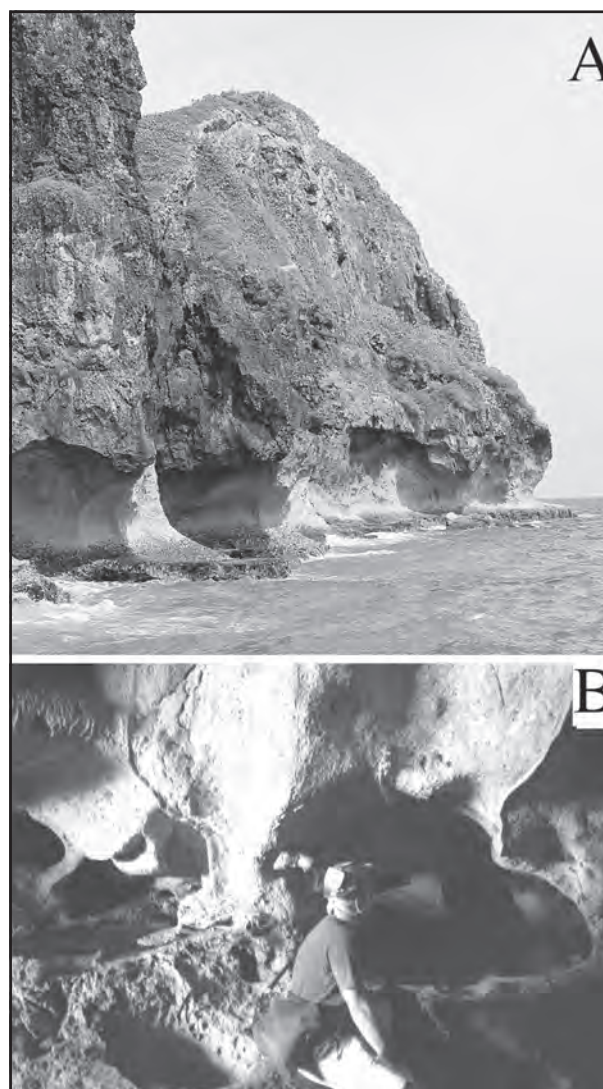

Figure 1: (A) Littoral erosion of northern escarpment of Puerto Rico. (B) Characteristic complex cusped morphology of a flank margin cave perimeter, Cueva Hermina Grande, northern coastline.



Figure 2: (A) Map of Cueva Hermina Grande – flank margin cave formed within the north coast Aymamon Limestone. (B) Profile view illustrating north coastline flank margin cave development as a function of elevation (meters) above current mean sea level.

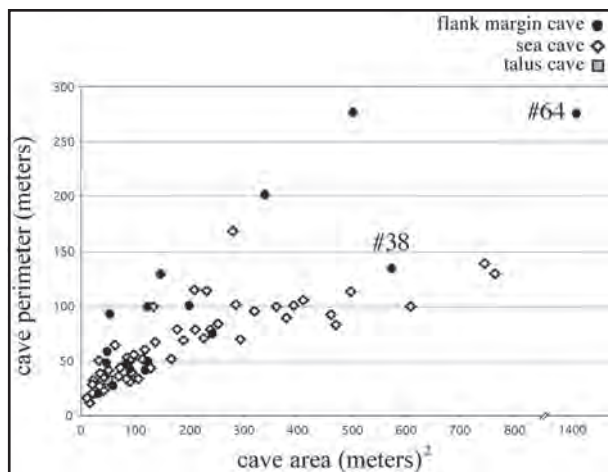

Figure 3: Morphometric differentiation of coastal caves in Puerto Rico. Plot of cave area versus cave perimeter for coastal cave sites with a total area less than 1500 square meters. Flank margin caves are indicated as solid circles, sea caves as open diamonds and talus caves as shaded boxes. Cave sites #38 and #64 indicate flank margin structures modified by significant littoral overprinting.

3.2 Coastal cave development as a function of previous glacioeustatic sea level stands.

As noted in other carbonate platforms, flank margin cave development on Puerto Rico appears to be mediated by the complex interplay of tectonics and dissolution processes associated with previous glacioeustatic sea level stands. Distinct flank margin “cave horizons” (i.e. discrete location of flank margin features as a function of sea levels, past and present) have been documented in the Mariana Islands (Jenson et al., 2006; Toepke, 2003). Isla de Mona, located 40 km west of Puerto Rico, also displays a well-defined horizon of flank margin caves on its eastern coastline. Significant tectonic uplift has raised this limestone platform up to 70 meters above current sea level with a significant number of caves located a few meters below the crest of the plateau and frequently associated with the contact between the Lirio limestone and the underlying Mona dolomite (Fig. 4A).

While the coastal stratigraphy of the Puerto Rican mainland is distinct from that on Isla de Mona, flank margin caves examined on the northern coastline, while not restricted to a defined bedding contact, also appear to segregate into multiple horizons as measured by their elevation above current sea level (Fig. 2B and Fig. 4B). This suggests that multiple previous sea level stands supported saltwater/freshwater lens stabilities of sufficient duration to allow measurable flank margin cave development. A plot of total flank margin cave area versus cave elevation was used as an indirect measure of lens stability as it relates to flank margin speleogenesis defined by overall cave morphology in



Figure 4: (A) View of cliffside entrances to Sistema Faro on the eastern coast of Isla de Mona, Puerto Rico. Note well-defined elevation associated with flank margin cave development at the Lirio limestone/Mona dolomite contact (or “cave horizon”) below the crest of the plateau at 40 meters above mean sea level, as indicated by the arrow. (B) Structure of the northern shoreline of Puerto Rico with elevations associated with flank margin cave development at 8 and 35 meters above sea level.

this setting (Fig. 5A). At least four potential cave horizons ranging from 0–5, 10–15, 20–25 and 30–35 meters were identified. In contrast, sea caves within this data set were only identified at elevations within 0 to 5 meters of current sea level. Morphometrics can also quantify the degree of secondary modification of coastal cave structures (Lace, 2008). In contrast to sea caves, flank margin caves are formed as entranceless chambers which are typically breached by cliff retreat mechanisms; therefore, as cliffline denudation progresses, the entrance breach dimensions

become larger relative to the remaining cave structure. A range of flank margin caves, exhibiting varying degrees of structural denudation, have been identified on the north coast of Puerto Rico. While intact flank margin caves (exhibiting entrance width to internal width ratios less than 0.5) were identified at multiple elevations, significantly denuded examples appeared to be more prevalent at elevations greater than 10 meters (Fig. 5B).

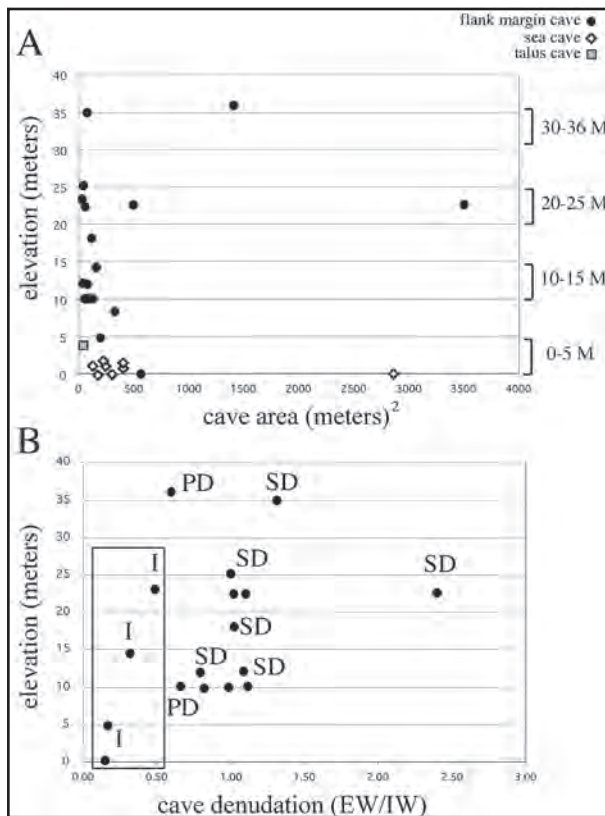

Figure 5: (A) Plot of total cave area versus cave elevation (relative to contemporary mean sea level). Flank margin caves are indicated as solid circles, sea caves as open diamonds and talus caves as shaded boxes. (B) Plot of degree of Cave Denudation (the ratio of maximum entrance width to maximum internal width) versus cave elevation in meters for the flank margin cave data set, where I = intact structure, PD = partially denuded and SD = significantly denuded.

In contrast to tectonically-stable platforms like the Bahamian archipelago or the Yucatan coastline where sea level records are primarily determined by glacioeustasy, tectonically-active carbonate platforms, such as those in the Greater Antilles and the Marianas (Jenson et al., 2006), complicate the interpretation of cave development as a function of precise sea levels due to tectonic overprinting of these uplifted carbonate platforms as one would predict (Gunn and Lowe, 2000). Talus caves, which are generated

by mechanical displacement of shoreline segments as a result of progressive cliff retreat, are effectively independent of glacioeustatics. Consequently, the morphology of these structures would not necessarily be expected to permit morphometric segregation of these features with structures formed by mixing zone dissolution or littoral erosion (Fig. 4). Other coastal cave structures, such as tafoni, which are formed by salt air erosion, are also considered independent of glacioeustatics and can be easily mistaken for littoral features, thus tafoni are not reliable indicators of previous stillstands (Walker et al., 2008). Morphometric analysis of tafoni structures results in a non-proportional perimeter (P) vs. area (A) trend that is distinct from that derived from both sea cave and flank margin caves (Owen, 2007). While coastal conditions in Puerto Rico could have theoretically supported tafoni cave development (Sunamura, 1996), no such structures have been documented in this setting to date.

4. Conclusions

In summary, detailed examination of coastal cave resources in the Commonwealth of Puerto Rico has identified numerous examples of flank margin cave development within Miocene-aged limestones and eolian calcarenites of contemporary and paleoshoreline structures. These morphologically distinct features, readily identified by their hallmark complex cusped perimeter, were quantitatively distinguished via morphometric analysis from sea cave examples within the same setting. While secondary processes (e.g. littoral overprinting) can potentially mask the primary mechanisms of speleogenesis, even significantly denuded flank margin caves were distinguishable from sea caves within the defined limitations of morphometric modeling (Lace, 2008; Roth, 2004; Waterstrat, 2007). Quantitative determination of previous stillstands in complex carbonate platforms subjected to tectonic overprinting can be problematic. However, both flank margin and sea cave development as a function of current elevation provides an approximation of previous glacioeustatic sea level stands. Flank margin caves were also identified at multiple elevations along the northern Atlantic shoreline, indicating multiple previous sea level stands, ranging from 0 to 35 meters above current sea level. Interestingly, sea caves were only found within the first cave horizon (0 to 5 meters); this may be consistent with a model in which littoral structures (Moore, 1954) are inherently more vulnerable to degradation via progressive cliff retreat and exposed to such processes for a longer period than those associated with contemporary shorelines. Similarly, the limited number of significantly denuded flank margin caves identified to date are located at higher elevations (i.e.

>10 meters). This study supports the expanding application of morphometric analysis of overall cave structure as demonstrated in this and other coastal settings (Labourdet et al., 2007; Mylroie and Mylroie, 2008) and illustrates the potential of applying morphometrics to modeling coastal processes that have shaped these intricate shoreline structures.

References

- Dasher, G. (1994) *On Station*. National Speleological Society, Huntsville, Alabama, 242p.
- Frank, E.F.; Mylroie, J.E.; Troester, J.W.; Alexander, E.C. and Carew, J.L. (1998) Karst development and speleogenesis on Isla de Mona, Puerto Rico. *Journal of Cave and Karst Studies*, **60**(2), 73–83.
- Gines, A. and Gines, J. (2007) Eogenetic karst, glacioeustatic cave pools and anchialine environments on Mallorca Island: a discussion of coastal speleogenesis. *International Journal of Speleology*, **36**(2), 57–67.
- Gunn, J. and Lowe, D.J. (2000) Speleogenesis in tectonically active carbonate islands, in Klimchouk, A.B., Ford, D.C., Palmer, A.N., and Dreybrodt, W., (eds.), *Speleogenesis: Evolution of Karst Aquifers*. National Speleological Society, Huntsville, Alabama, pp.238–243.
- Jenson, J.W.; Keel, T.M.; Mylroie, J.R.; Mylroie, J.E.; Stafford, K.W.; Taborosi, D. and Wexel, C. (2006) Karst of the Mariana Islands: The interaction of tectonics, glacioeustasy and fresh-water/sea-water mixing in island carbonates. *Geological Society of America Special Paper 404*, pp. 129–138.
- Kambesis, P.N.; Burger P.; Lace, M.J. and Despain, J. (2009) Coastal karst of Caguanes National Park, Sancti Spiritus, Cuba. *Proceedings of the 15th International Congress of Speleology*, Kerrville, Texas (in press).
- Kaye, C.E. (1959) Shoreline features and Quaternary shoreline changes, Puerto Rico. Geological Society Professional Paper #317-B, United States Geological Survey, 140p.
- Kelley, K.N.; Mylroie, J.R.; Mylroie, J.E.; Moore, C.; Moore, P.J.; Collins, L.; Ersek, L.; Lascu, I.; Roth, M.; Passion, R. and Shaw, C. (2006) Eolianites and karst development in the Mayan Riviera, Mexico, in Davis, R.L. and Gamble, D.W., eds., *Proceedings of the 12th Symposium on the Geology of the Bahamas and other Carbonate Regions*, pp.88–98.
- Labourdet, R.; Lascu, I., Mylroie, J.E. and Roth, M. (2007) Process-like modeling of flank margin caves: from genesis to burial evolution. *Journal of Sedimentary Research*, **77** (11), 965–979.
- Lace, M.J. (2008) Coastal cave development in Puerto Rico. *Journal of Coastal Research*, **24**(2) 508-518.
- Lugo, A.E.; Castro, L.M.; Vale, A.; del Mar Lopez, T.; Prieto, E.H.; Martino, A.G.; Puente-Rolon, A.R.; Tossas A.G.; McFarlane, D.A.; Miller, T.; Rodriquez, A.; Lundberg, J.; Thomlinson, J.; Colon, J.; Schellekens, J.H.; Ramos, O. and Helmer, E. (2001) *Puerto Rican karst - a vital resource*. USDA and Forest Service General Technical Report WO-65, 100p.
- Miller, T. (2004) Structural control on cave development in Cretaceous Limestone, southern Puerto Rico. *Caribbean Journal of Science*, **40**(2), 276-280.
- Monroe, W. H. (1976) Karst landforms of Puerto Rico. Geological Survey Professional Paper #899, United States Geological Survey, 69p.
- Monroe, W.H. (1980) *Some tropical karst landforms of Puerto Rico*. Geological Survey Professional Paper #1159, United States Geological Survey, 39p.
- Moore, D.G. (1954) Origin and development of sea caves. *National Speleological Society Bulletin*, **16**, 71-76.
- Mylroie, J.E. and Carew, J.L. (1990) The flank margin model for dissolution cave development in carbonate platforms: *Earth Surface Processes and Landforms*, **15**, 413–424.
- Mylroie, J.E. and Carew, J.L. (2000) Speleogenesis in young limestones in coastal and oceanic settings, in Klimchouk, A.B; Ford, D.C.; Palmer, A.N. and Dreybrodt, W. (eds), *Speleogenesis: Evolution of Karst Aquifers*. National Speleological Society, Huntsville, Alabama, pp. 226–233.
- Mylroie, J. E., Mylroie, J. R., Jenson, J. W., and MacCracken, R. S., 2008, Fresh-water Lens Anisotropy and Flank Margin Cave Development Fais Island, FSM, in Freile, D., and Park, L., eds., *Proceedings of the 13th*

Symposium on the geology of the Bahamas and other carbonate regions, p. 135–139.

Mylroie, J.E. and Mylroie, J.R. (2007) Development of the carbonate island karst model. *Journal of Cave and Karst Studies*, **69**(1), 59–75.

Mylroie, J.E. and Mylroie, J.R. (2008) Flank margin cave development in telenetic limestones of New Zealand. *Acta Carsologica*, **37**(1), 15–40.

Owen, A.M. (2007) *Tafoni caves in Quaternary carbonate eolianites: examples from the Bahamas*. Master's Thesis, Department of Geosciences, Mississippi State University, 187p.

<http://library.msstate.edu/etd/show.asp?etd=etd-05142007-143443>

Roth, M. J., 2004, *Inventory and geometric analysis of flank margin caves of the Bahamas* [MSc. thesis]: Mississippi State University, 117 p.

<http://library.msstate.edu/etd/show.asp?etd=etd-07062004-164930>

Smart, P.L., Beddows, P.A., Coke, J., Doerr, S., Smith, S. and Whitakker, F.F. (2006) Cave development on the Caribbean Coast of the Yucatan Peninsula, Quintana Roo, Mexico, *in* Harmon, R.S. and Wicks,

C. (Eds.) – *Perspectives on Karst Geomorphology, Hydrology and Geochemistry*. Geological Society of America Special Paper #404, pp. 105–228.

Sunamura, T. (2006) A physical model for the rate of coastal tafoni development. *Journal of Geology* **104**, 741–748.

Toepke, Kevin (2006) *GIS analysis of the caves and karst of the Mariana Islands*. Master's Thesis, Department of Geosciences, Mississippi State University, 670p.

<http://library.msstate.edu/etd/show.asp?etd=etd-02242006-141222>

Vacher, H.L. and Mylroie, J.E. (2002) Eogenetic karst from the perspective of an equivalent porous medium. *Carbonates and Evaporites*, **17**(2), 182–186.

Walker, L.N., Mylroie, J.E., Walker, A.D. and Mylroie J.R. (2008) The caves of Abaco Island. *Journal of Cave and Karst Studies*, **70**(2), 108–119.

Waterstrat, W.A. (2007) *Morphometric differentiation of flank margin caves and littoral, or sea caves*. Master's Thesis, Department of Geosciences, Mississippi State University, 201p.

<http://library.msstate.edu/etd/show.asp?etd=etd-04052007-150907>

GEOMORPHIC AND ARCHEOLOGICAL FEATURES OF COASTAL CAVES IN MADRE DE DIOS ARCHIPELAGO (PATAGONIA, CHILE)

RICHARD MAIRE^{1,2}, BERNARD TOURTE², STÉPHANE JAILLET², JOEL DESPAIN³, BENJAMIN LANS¹, FRANCK BREHIER³, LUC-HENRI FAGE², LAURENT MOREL⁴, MARC POUILLY⁵, THIBAUT DATRY⁶, MARC MASSAULT⁷, DOMINIQUE GENTY⁸, CHRISTOPHE MOREAU⁹, KARINE WAINER⁸, VINCENT RIDOUX¹⁰, WILLY DABIN¹⁰, JEAN-FRANÇOIS PERNETTE², MARCELO AGÜERO FARIDONI¹¹, MARIA-JOSE MANNESCHI¹²

¹CNRS, Lab. ADES, 12 Esplanade des Antilles, 33607, Pessac cedex, France, rmaire@ades.cnrs.fr

²Association Centre-Terre, Pasquet, 33760, Escoussans, France

³National Park Service, Sequoia and Kings Canyon National Park, CA 93271, USA

⁴Université de Lyon 1. ⁵IRD. ⁶Cemagref, Lyon. ⁷Université d'Orsay. ⁸LSCE, CEA-CNRS, Saclay. ⁹Artemis, CEA, Saclay

¹⁰Université de la Rochelle. ¹¹Asociacion Chilena de Espeleologia, Santiago. ¹²Universidad de Chile, Santiago

Located at 50°30' S, Madre de Dios archipelago is an outstanding natural and archeological heritage site, which Chile designated a protected area in January 2008. Together with Diego de Almagro Island (51°30'S), this is the most southerly and inhospitable karst on Earth, owing to a subpolar climate with extreme rainfall (>7–8 meters/year) and strong winds ("roaring fifties"). The Upper Carboniferous and Lower Permian Tarlton Limestones (500 m thick) form part of the pre-Jurassic basement of the Andean Cordillera, the former Pacific margin of Gondwana. Along the fjords and Pacific front, cliff-side exploration with rubber dinghies has revealed three exceptional caves with: (1) archeological artifacts (Pacific Cave); (2) glacial sediments (Moraine Cave); (3) stepped beaches and whale bones (Whale Cave).

Discovered in 2006, Pacific Cave is the first archeological cave found in the Patagonian islands containing paintings from the Kawésqar culture. This marine cave, 3 m above sea level, contains thick shelly deposits (limpets), bone fragments, fireplaces with charcoal and 50 paintings. Thirty were made with red ocher (anthropomorphic figures, "sun-wheel"). Geochemical analyses with a portable X-ray analyzer (Niton) indicate about 1 to 3 % of iron. Twenty drawings were made with charcoal, and one seems to represent a galleon. Because of recent glacio-isostatic uplift (main upper horizontal shoreline at +3 m), the age of the drawings is probably between several hundred and about 3000–4000 years. The oldest known burial site is 4520 ±60 years BP in Ayayema Cave (+10 m), explored in 2000.

Moraine Cave has a 40 m large entrance situated 50 m above sea level on the west front of Guarello Island; it is filled by a 25-m-thick morainic deposit with interbedded varves. The oldest stalagmite is 9055 ±915 years BP. Three stepped horizontal wall notches at about +55 m are not yet interpreted.

Whale Cave contains a huge entrance, 70 m high and 50 m wide, located on the Pacific front, but perpendicular to the swell direction. This karstic cave, 180 m long, contains several stepped pebble marine terraces at +5 m, +7 m, +9 m, and +10.5 m, all with granite pebbles carried from the eastern part of the island by glaciers. Many whale bones (6 skulls, many vertebrae, and ribs), especially blue whale and *Hyperodon*, are dispersed throughout the middle and bottom parts of the cave between +7 and +11.5 m. Two ¹⁴C dates indicate ages of 3200 ±100 years BP at +9 m, and 2600 ±60 years BP for another whale bone at +37 m, suggesting deposition by a tsunami. All these karst and archeological features recorded in littoral caves provide an understanding of the complex evolution of this coastal area since the last deglaciation and the origin of Kawésqar occupation.

1. Introduction

The karst areas of Madre de Dios archipelago, called the "marble glaciers," remained virtually unknown until 1995–2000 because of their remoteness and very inhospitable

climate (Maire et al., 1999) (Fig. 1). Speleological research has begun both on the marble glaciers and along the coast, first in the fjords and then on the wild Pacific coast (Pernette et al., 2009). This new type of coastal speleology with rubber

dinghies allowed us to discover some major caves with significant archeological, paleontological, sedimentological, and paleoenvironmental information. The Permian and Carboniferous limestones (Tarlton limestones) are located between Upper Paleozoic volcano-sedimentary formations on the south and west (Duque de York Formation) and the Mesozoic granites of the Patagonian Batholith on the east. These carbonates, with many dikes, correspond to corallian paleoreefs, part of an accretionary prism of the Gondwana paleocontinent. Recent Kr-Ar dating of biotite indicates 133-140 Ma for the intrusions in limestones related to the magmatic activity of an ancient volcanic arc (Duhart et al., 2003). We observed some residual fragments of the old oceanic floor (Denaro Complex).



Figure 1: Location of Madre de Dios archipelago in southern Chile.

Madre de Dios (50°30'S) is located on the isotherm +7°C, at the northern limit of the subpolar isothermic climate (Zamora and Santana, 1979). In Guarello meteorological station, the precipitation is 7000–8000 mm/yr and the mean wind speed is 70 km/hour from the northwest. The annual thermal amplitude is weak, about 5 to 6°C. In protected places, the vegetation is characterized by the primitive magellanic forest with the genus *Nothofagus* inherited from Gondwana. The southern edge of Madre de Dios was almost completely covered by ice during the last cold period, except for some limestone nunataks. Glacial striations are preserved only in a few places under talus, as at Guarello. Moraines are very rare because they have been flooded by the postglacial transgression. However, erratic blocks are numerous, up to altitudes of 400 m, showing a huge postglacial dissolution of 1.50 m (Maire et al., 2009; Despain et al., 2009).

2. Pacific Cave: The First Kawésqar Paintings of the Patagonian Archipelagos

Pacific Cave, located at the exit of Azul fjord, along the Pacific coast, is 25 m long, 10 m wide and 4 m high. Discovered here in 2006 were the first cave paintings of the Patagonian archipelagos. Their study is essential for a better understanding of the cultural heritage of the Kawésqar people, now almost vanished. Only a very small Kawésqar community of 17 people lives now in Puerto Eden.

The importance of shelly deposits (limpets) covering 100 m² suggests a frequent occupation during a long period. There are also many bones of seabirds and several fireplaces with charcoal. There are 50 painted objects, including 30 of red ochre and 20 of charcoal. The main panel is at the bottom, darkest part of the cave. The other paintings are situated at heights between 0.5 m and 4 m. Anthropomorphic figures are the most numerous (11), followed by geometric drawings like “sun wheels” (Fig. 2). According to the ethnographic grid (Emperaire, 1955), a horned anthropomorphic figure could correspond to Kawtcho, the Kawésqar divinity. The charcoal drawings are situated lower, 70 cm from the floor. Among the identifiable drawings is a “sun wheel,” some anthropomorphic figures, and a sketch of a boat, probably the back of a galleon. If this interpretation is correct, the picture could be 400 to 500 years old and related to the first contact with Europeans.



Figure 2: Ocher paintings in Pacific Cave (“sun wheel” an anthropomorphic figure) (photo L.H. Fage).

The outer part of the cave, near the entrance, has a few modern remnants. A date on the wall (1961?) and some recent debris are evidence of later use of this shelter. Re-use of the site is also reflected by a series of four small red ochre drawings. The technique used appears to be smear painting and suggests a late addition. Five non-destructive analyses with a portable X-ray unit (Niton) confirmed that the red ochre paintings, at the bottom of the cave, are rich in iron

oxide, Fe_2O_3 ($\text{Fe} = 10,900 \pm 400$ to $27,000 \pm 600$ ppm) (Fig. 3). The charcoal paintings contain 1230 to 1630 ± 30 ppm of strontium. By comparison, the Sr content in the Tarlton limestone is 200 to 400 ± 10 ppm and in ocher 120 to 140 ± 9 ppm. All of the figures show artistic activity over a fairly long period. On the mainland, in the Pampa and Tierra del Fuego, the oldest human settlements are dated to $11,000$ – $12,000$ BP. But in the islands, the settlements are much more recent, around 6000 – 6500 BP, both in the Beagle Channel in the Strait of Magellan and in the Otway Sea (Legoupil, 1995).



Figure 3: Measurement of ocher paintings with a μ -XRF portable unit (photo B. Tourte).

Discovered in 2000, the oldest burial site of Madre de Dios is located in Ayayema Cave at $+10$ m; it dates from 4520 ± 60 BP (Legoupil and Sellier, 2004). Because of the marine origin of the Pacific Cave and its low altitude ($+3$ m), the occupation cannot be older than the last few millennia. The area was exposed above sea level by recent glacio-isostatic uplift, e.g., at Whale Cave since 3000 BP (infra §4). Indeed, the main marine notch is at about $+3$ m, the same altitude as the shelly deposit, but the rocky floor of the Pacific Cave is lower. Elsewhere, recent radiocarbon dating of human bones indicates 630 – 690 BP for a burial shelter in Barros Luco and 730 – 920 BP for Bahia Historica Cave in Whale Beach (2 Sigma calibration, Beta Analytic, Miami). The first anthropological examinations of bones in Barros Luco shelters show the evidence of Mongoloid features. The radiocarbon ages prove a Prehispanic occupation on the Pacific front, but very probably from land routes highlighted in 2008, for example between Seno Soplador and Whale Beach. Indeed it was highly unlikely for Kawésqar people to navigate the Pacific Ocean with their fragile canoes.

3. Moraine Cave: A Record of the Last Deglaciation

Discovered in 2000, Moraine Cave is located at $+50$ m on

the west coast of Guarello Island in Seno Eleuterio. The large entrance, 35 m high, is protected by the magellanic forest. The Moraine Cave is the inactive part of a karstic system whose waters emerge today through bedrock blocks a few meters above sea level. Floods in the cave may exceed $1 \text{ m}^3/\text{sec}$. This system probably relates to the Three Lakes Sinkhole 1 km to the east (altitude 90 m) (Jaillet et al., 2008). The cave is formed by a main entrance hall 100 m long, 40 – 50 m wide and 30 to 40 m high. It is partially filled by a thick morainic deposit over 20 m on the left (south) side. In the entrance, the vertical section shows (1) a lower unit, 8 m high, composed of gravel and blocks cemented by compact glacial flour; (2) an intermediate varve level 0.6 m thick; (3) an upper unit, 10 m thick, similar to the lower unit (Fig. 4). It contains many limestone fragments, and also some of granite from the batholith (eastern part of Madre de Dios), as well as sandstone and conglomerate from the volcano-sedimentary formation of Duque de York.

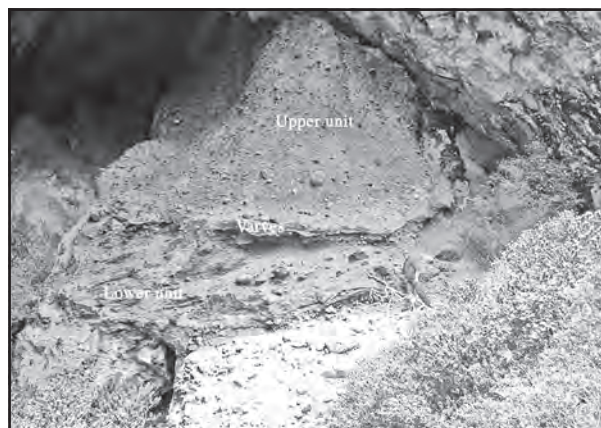

Figure 4: The morainic deposit at the entrance of Moraine Cave. Note figure at right center for scale (photo R. Maire).

A small gallery, 50 m long, was formed on the left bank between the deposit and the wall. It contains speleothems and the same intermediate level of varves. An active stalagmite, 30 cm high, was sampled directly on the eroded moraine edge. A first U/Th dating (TIMS) made on the bottom calcite indicates an age of 9055 ± 915 yr BP (analysis K. Wainer, LSCE). It is clear that the thick moraine deposit is linked to the last glaciation, and probably to the phase of deglaciation between $20,000$ and $10,000$ years BP. Indeed, this deposit is related to a large glacial sinkhole located on the left bank of the Eleuterio glacier. Large eroded and broken stalactites, on the floor in the deep part of the room, are evidence for glacial floods after the subterranean morainic injection. This specific hydrology, with temporary artesian conditions, would have been responsible for a reverse hydrologic pattern in the karst system. Indeed, in the inclined dry tubes of Three Lakes

Cave, the orientation of scallops is opposite to today's flow direction (Jaillet et al., 2008).

This morainic complex trapped in a cave is unique in Madre de Dios. It offers a record of the various episodes of the last deglaciation phases separated by an erosional phase and varve sedimentation, which could correspond to rapid events of Dansgaard-Oeschger type. Furthermore, on the right bank of the entrance hall, three big horizontal notches seem related to former glacial lake levels. Several types of solution notches were observed in other caves, especially in the Whale Bay area.

4. Whale Cave: A Holocene Marine Cemetery

With very difficult of access either by sea or land, Whale Cave is the largest cave chamber of Madre de Dios: 180 m long, 40 m wide and 30 to 50 m high (Fig. 5). Opening directly along the Pacific coast, on the north side of the Whale Bay, the huge 70 m high entrance is oriented south, perpendicular to the swell direction (west to northwest). It contains a remarkable whale cemetery discovered in 2000. All the bones are scattered and are not articulated; they are situated in the middle and bottom of the room on several stacked marine terraces. Five skulls of blue whales and one of *Hyperodon* (determination V. Ridoux, W. Dabin) and numerous vertebrae and ribs were observed between +5 m and +11.5 m. Four terrace levels are preserved and were surveyed in 2008 with a theodolite: the +5.7 m terrace in continuity with the upper marine notch of +56 m; the +7 m terrace, the most important, in the central part of the cave; the +9 m terrace (with collapse blocks) showing the most important accumulation of bones; and the +10.5 m residual terrace visible only in the northern part of the room (Figs. 6, 7). The fine matrix of the highest terrace (+10.5 m) is whitish because of weathered bones and guano (phosphate).



Figure 5: The main marine terrace (+7 m) in Whale Cave. Note figure in center for scale (photo R. Maire).

A petrographic study of cobbles was conducted on the terraces. Between 98 and 115 rock samples were examined at each of three sites: (1) outside the cave entrance and along the ocean margin (modern terrace); (2) inside the cave's large entrance room, terrace at +5.7 m amsl; and (3) deeper into the cave at +9 m. Samples varied in areal extent, as did rock sizes and conditions. The ocean margin site was 0.04 m² with rounded cobbles ranging from 2-10 cm on their long axis with no signs of recent breakage. The entrance room site included cobbles from 4 x 4 m of cave floor, with some angular rocks and 15 broken or fractured stones. They ranged in size from 4-25 cm. The interior cave site (+9 m) included two sediment deposits 1.5 m apart and both approximately 3 m above an active stream. Stones were 1 to 2 cm in size with no larger ones present. Approximately 30 cobbles had been broken or fractured. All broken faces displayed a weathering rind not seen on those in the entrance room. Also of note at the interior site were banded sediments, many displaying dark coloration from organic matter.

The petrographic results point to two different influences on the development of Whale Cave. A small stream initially formed the cave and its influence still dominates the sediments and cave development in the deep cave area. Granitic rocks are not found in the watershed of the stream and so are not present in the sediment deposit found here. The weathering rinds on the stones in this area reveal the relative antiquity of the deposits. The small size of the rocks points to the limited ability of a small stream to carry larger ones into the cave. The fine-grained and banded sediments are also likely of fluvial and not marine origin. The lower parts and the large entrance room of the cave were later inundated by marine water, which deposited more recent sediments of similar origin to the modern sediments and cobbles in the high-tide zone adjacent to the Pacific and just outside the cave entrance. Here we find granitic rocks that have been transported greater distances by wave and tide action compared to the fluvial deposits, and larger stones that must have been carried by powerful marine action.

Clear differences were also documented in the sediments of the cave. On the seacoast just outside the cave entrance and within the cave's first and largest room, small rounded cobbles include approximately 10% plutonic rocks (granite); but at the rear of the cave no granite was found; cobbles were limited only to limestone with a few pieces of volcanic rock. Outcrops of plutonic rocks are not present near the cave and would likely have been transported into the area only by glaciers and by the action of the ocean. In addition, fine sediments in the first large cave room are exclusively sand without layers or lamination. At the rear

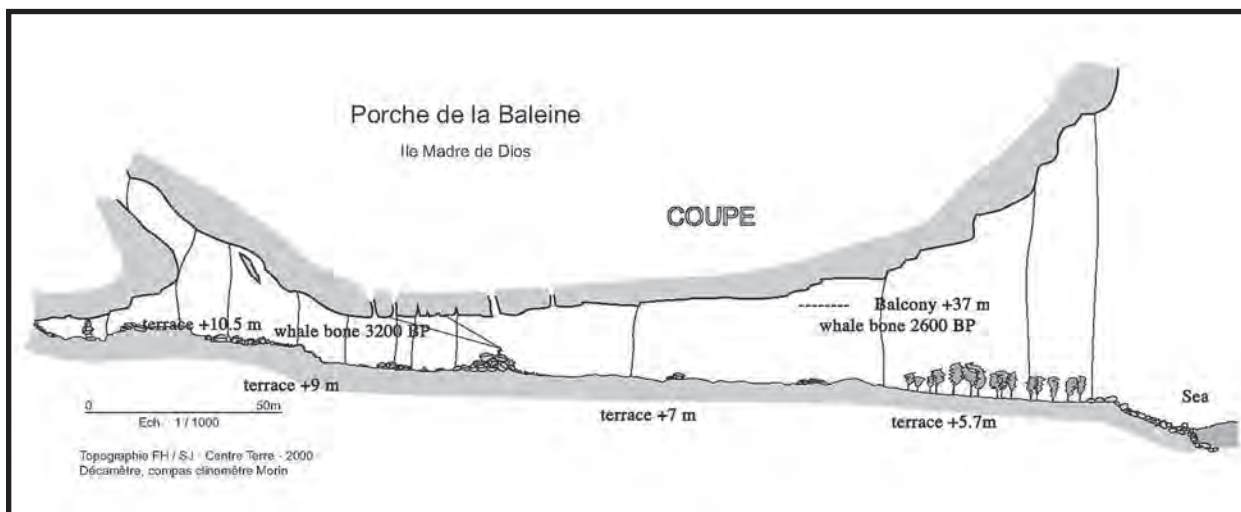

Figure 6: Longitudinal section of Whale Cave with location of marine terraces and radiocarbon datings.

of the cave, sediments are much finer (silt or even clay-size) and are clearly laminated and layered. This evidence points to a double origin for Whale Cave: initial cave-passage development through the action of a cave stream, and significant enlargement of the cave's large entrance room by the actions of the Pacific, which deposited the sand and granite fragments.

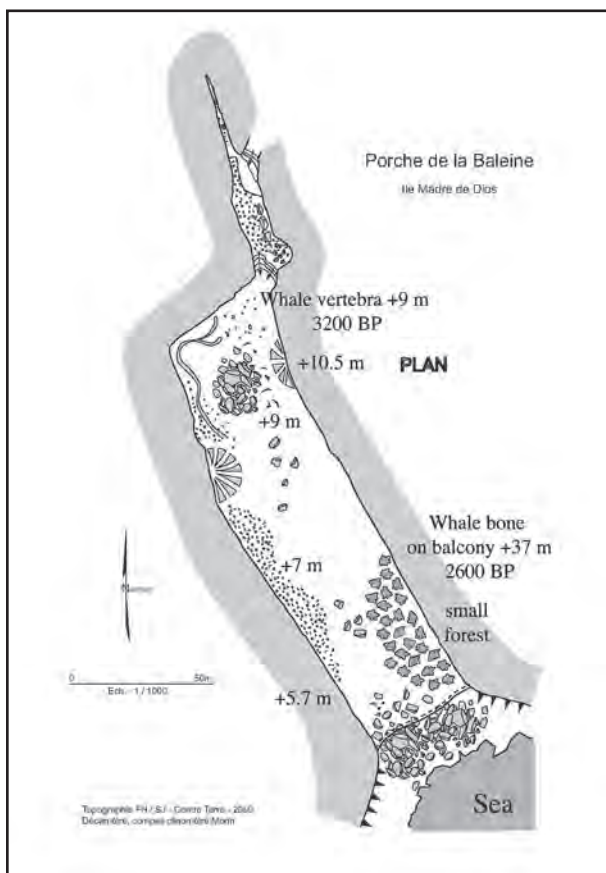

Figure 7: Map of Whale Cave (S. Jaillet).

A first radiocarbon date was obtained from a whale vertebra in the deep area at +9 m (Fig. 8). The age is 3200 ± 100 years BP (analysis: Marc Massault, CEA/Saclay). Our first interpretation is that the whales were transported into the cave by currents, tides and waves when the cave floor was lower, before the recent glacio-isostatic uplift. The disarticulated skeletons spread over a distance of 150 m, with a clear predominance toward the bottom of the cave, showing the effect of storms. But there is another complementary explanation. During the first descent into the cave from the top of the cliff, we discovered whale vertebra and several other bones in anatomical connection, on a balcony 5 m wide situated at +37 m, as well as a few limpet shells indurated by calcite. A radiocarbon date of a piece of bone shows an age of 2600 ± 60 yr BP (analysis: M. Massault, C. Moreau, CEA, Saclay). Because of the orientation and altitude of the cave entrance, only a tsunami can explain the presence of whale bones at +37 m. This hypothesis explains the dispersion of the bones throughout the rear of the cave, and also within a fissure between +10 m



Figure 8: Whale vertebra in the rear of Whale Cave (terrace +9m), age 3200 ± 100 BP (photo R. Maire).

and +11.5 m. Earthquakes and tsunamis occurred along the Chilean coast during the Pleistocene.

5. Conclusions

Located at the ocean-island contact, the different types of coastal caves of Madre de Dios have preserved many records of first human impact and environmental evolution: cave paintings, burial sites, whale bones, glacial sediments, stages of marine terraces, and old horizontal notches, all indicators impossible to have survived outside because of glacial erosion and Holocene dissolution. The relationship between these karst records and the recent glacio-isostatic uplift is one of the interesting perspectives of this research.

Acknowledgements:

to Ultima Patagonia Expeditions, Climanthrope program (ANR), CEA-Saclay and to Arthur Palmer for his advice and editing.

References

- Despain, J., Maire, R., and Jaillet, S. (2009) Morphological relationships between erratic boulders and associated bedrock limestone fins or "rock comets," Madre de Dios archipelago, Chile. Proceeding of 15th International Congress of Speleology, National Speleological Society, Huntsville, Alabama, (this volume).
- Duhart, P., Munoz, J., Tassinari, C.C.G., and Quiroz, D. (2003) K-Ar geochronology and Sr and Nd isotopic composition of the Patagonian Batholith in the Madre de Dios archipelago (50° 30'S), Southern Chile. South American symposium on isotope geology, Salvador, CBPM-IRD, 542–544.
- Empereire, J. (1955) Les Nomades de la Mer. Le Serpent de Mer (ed. 2003), 344 p.
- Jaillet, S., Maire, R., Brehier, F., Despain, J., Lans, B., Morel, L., Pernette, J.-F., Ployon, E., Tourte, B., et tous les membres d'Ultima Patagonia 2000, 2006 et 2008 (2008) Englacement, eustatisme et réajustements karstiques dans l'archipel de Madre de Dios (Patagonie, Chili). *Karstologia*, **51**, 1–24.
- Legoupil, D. (1995) Des indigènes au cap Horn: conquête d'un territoire et modèle de peuplement aux confins du continent sud-américain. *Journal de la Société des Américanistes*, **81**, 9–45.
- Legoupil, D., and Sellier, P. (2004) La sepultura de la Cueva Ayayema (Isla Madre de Dios, Archipiélagos occidentales de Patagonia). *Anales des Instituto de la Patagonia*, **32**, 115–124.
- Maire, R., and équipe Ultima Patagonia (1999) Les « glaciers de marbre » de Patagonie, Chili. Un karst subpolaire océanique de la zone australe. *Karstologia*, **33**, 25–40.
- Maire R., Jaillet, S., and Hobléa, F. (2009) Karren in Patagonia (Chile), A natural laboratory for hydroeolian dissolution. In *Karst rock features, karren sculpturing*, Gines, A., ed., International Union of Speleology (in press).
- Pernette, J.F., Tourte B., and Maire R., (2009) The Centre-Terre expeditions to Patagonian karst islands: a historic overview. Proceeding of "Karst Horizons" congress, UIS, Kerrville, Texas (this volume).
- Zamora, E. and Santana A. (1979) Características climáticas de la costa occidental de la Patagonia entre las latitudes 46°40' y 56°30'S. *Anales Inst. Patagonia*, Punta Arenas (Chile), **10**, 109–154.

COVA DES PAS DE VALLGORNERA: AN EXCEPTIONAL LITTORAL CAVE FROM MALLORCA ISLAND (SPAIN)

ANTONI MERINO, ANTONI MULET, GUILLEM MULET, ANTONI CROIX, AND FRANCESC GRÀCIA
Federació Balear d'Espeleologia. C/ Margarida Xirgu, 16. 07011 Palma de Mallorca. Spain.

The Cova des Pas de Vallgornera is located in the Lluçmajor municipality, Mallorca Island (western Mediterranean). It is the longest cave in the Balearic archipelago with a currently surveyed length of over 59,000 meters. The cave is notable not only because its development, but also for the great deal of uncommon speleothems and solutional morphologies related, at least partially, to the freshwater-seawater mixing zone. The cave is under the protection of Conselleria de Medi Ambient, Govern de les Illes Balears (the Regional Environmental Authority) and was declared a Site of Community Importance, within the Natura 2000 Network (European Council Directive 92/43/EEC). Access to the cave is restricted only to surveying and investigations authorized by the Regional Authority.

1. Historical Introduction

Cova des Pas de Vallgornera was discovered on the April 26, 1968, while drilling a cesspit for a hotel located in the Lluçmajor municipality, Mallorca Island (western Mediterranean (Fig. 1). During the following days, a representative from the Lluçmajor local Council along with a photographer undertook the first visit to the cave. The news about the discovery was published on the front page of "Diario de Mallorca" newspaper some days later. Between 1968 and 1969 some local caving clubs, Centro de Actividades Espeleológicas, Grup Espeleològic EST, and Espeleo Club Mallorca began its exploration. Subsequently, the hotel owner, a Belgian at that time, got in touch with a group of Belgian cavers from Groupe Speleo Namur Ciney and commissioned them to explore and survey the cave, with the aim of possibly opening it as a show-cave (Collignon, 1982). The report, based on that information, was negative

and those plans were abandoned. As a result of a meeting held between cavers from Grup Espeleològic EST and Secció d'Espeleologia de l'ANEM in 1990, it was decided to survey and study the cave in detail. The task began in 1991 and it was finished by the end of 1992, yielding about 2 km of passages (Fig. 2), the so-called Sector Antic (Merino, 1993).

On July 2, 1994, an important breakthrough came when two cavers from Grup Espeleològic EST enlarged a tight passage that led the explorers to new galleries and chambers. Early in the winter of that year, the survey of the new discoveries started, finishing on November 27, 1999; at that time the cave was 6.4 km long and included some extensive pools (Merino, 2000). That new sector was called Noves Extensions.

Cavers from Grup Espeleològic Llubí and Secció d'Espeleologia de l'Anem kept visiting the cave with the aim, among others, of continuing studies at remote spots of the cavern. From 2002, exploration focused on an area extending from the inner part of Llac de Na Gemma and Sala de Na Bàrbara. That interest was based on the existence of a slight draught that fluctuated in intensity and direction, from which a correlation between air pressure and water table level was established. As a first result, some new narrow galleries and a small chamber with a pool were found at the northern section of Sala de Na Bàrbara.

2004 was an important year in the history of Cova des Pas de Vallgornera. After a massive series of explorations, that took place starting in 2003, it was possible to follow the air flow in June 2004. Consequently, a slot with air flow was found that, once widened, gave explorers access to a series of small passageways. Eventually the cavers squeezed through a



Figure 1: Map of the western Mediterranean with the location of the Mallorca Island.

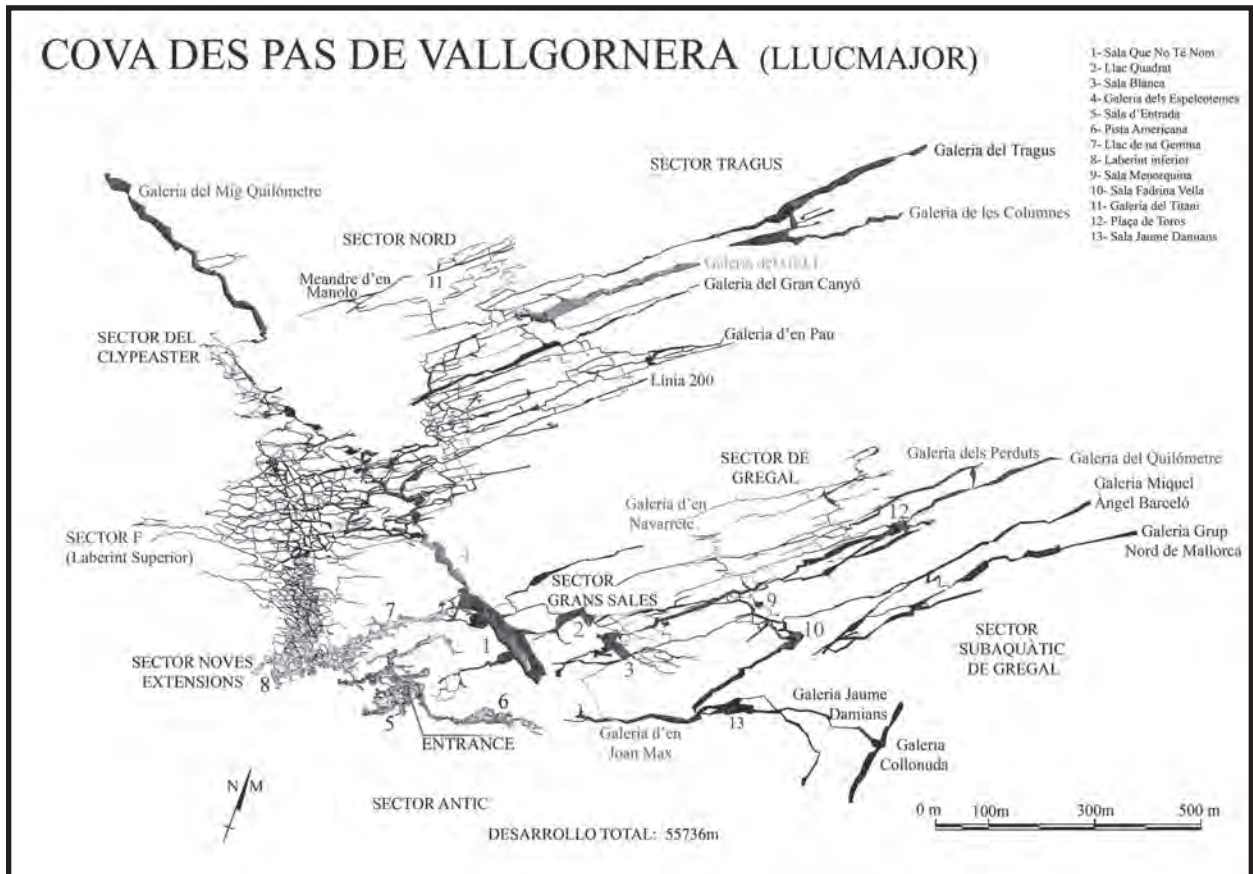

Figure 2: Survey of the cave with the main sectors identified.

tight slot that led them to the beginning of the Sala que No Té Nom, a vast chamber, the largest in the cave so far. Since that date, exploration and survey of the cave have continued without a break (Merino et al., 2006, 2007, 2008). With the ambitious aim of completing the exploration project, different local caving clubs, Secció d'Espeleologia Voltors, Grup Espeleològic EST, and cave divers from Grup Nord de Mallorca, joined in with Grup Espeleològic Llubi. Some research projects were also initiated with the participation of local scientific institutions, such as Universitat de les Illes Balears.

2. Description of the Cave

The cave could be clearly divided into three main parts: Sector Antic, Noves Extensions, and the most recently discovered sector known as Descobriments 2004 (Fig. 2). Sector Antic (Merino, 1993) is formed by a breakdown chamber, Sala d'Entrada and entered through the only known entrance to the cave, a 6 m deep man-made well. Stalagmitic flowstones cover and cement most of the large accumulation of boulders of different sizes that make up the floor. The chamber is lavishly decorated with stalactites, stalagmites and groups of columns that cause a slight

compartmentalization. A gour situated to the east side of the chamber shows the way to the Pista Americana. This gallery is floored with large boulders, whereas small brackish pools line the right-hand side of the passage which is scarcely decorated. The way leads on and opens into a chamber, Sala del Moonmilk, deriving its name from the great deal of moonmilk that covers the area. Close to the end of this uneven, low-roofed collapse chamber, a hole in the floor descends through boulders to the Vía Max passage, which displays the same features.

Back to the Sala d'Entrada and toward the northwest sector, a down-sloping constricted passage gives access to the brackish pools that make up the flooded section of Sector Antic and also the galleries that constitute the Noves Extensions (Merino, 2000). The Noves Extensions can be divided into two clearly different sectors: an impressive phreatic pools series and the Laberint Inferior maze. The former one is formed by Llac de Na Gemma and Sala de Na Bàrbara; the first section of that extensive phreatic pool is partially decorated with stalactites and soda straw forests, while the rest is totally devoid of formations and covered by corrosion morphologies. At the end of Llac de Na

Gemma, the gallery becomes narrower because of flowstones and boulders, arriving at Sala de na Bàrbara, a small flooded chamber with phreatic speleothems, stalactites, and stalagmites. The latter sector, the Laberint Inferior (lower maze) is formed by an irregular network of small passageways situated at the water table level, whose walls and roof are covered with solutional sculpturing, presumably generated by the highly aggressive brackish waters; the scarcity of speleothems in the area must be emphasized.

The Descobriments 2004 is where the cave reaches its longer and notable dimensions (Merino et al., 2006, 2007, 2008). Roughly speaking, the new galleries and chambers discovered in Cova des Pas de Vallgornera are neatly organized in two different levels, besides the underwater extensions. The first one is located at the water table level or slightly above it, where roof and walls have collapsed extensively. Chambers and passages of different sizes occur, some of them are impressively large, like Sala que No Té Nom, which has a length of 200 m and a width of 80 m. The second one, the upper level, is characterized by networks of rectilinear passages creating complex labyrinths. This upper level is likely to have existed in areas where currently larger and higher phreatic chambers and passages occur, but removed by collapse.

In the Descobriments 2004 series, up to seven new sectors can be easily distinguished: Sector de les Grans Sales, Sector de Gregal, Sector Subaquàtic de Gregal, Sector F, Sector del Clypeaster, Sector del Tragus and Sector Nord. The first one, Sector de les Grans Sales, is an assemblage of breakdown chambers heading in a northwest-southeast direction, ringed by phreatic water pools. Sala que No Té Nom and Llac Quadrat are good examples, as well as smaller chambers like Sala Blanca. The existence of large boulders that floor the chambers is the common denominator to all of them. Moreover, speleothems are rather scarce and some of them are significantly affected by decalcification processes. As a consequence of boulders' settling, some flowstones that cover the floors are cracked and broken.

Sector de Gregal and Sector Subaquàtic de Gregal, located at the water table level or below it, stand out because of their dimensions; some of the most important galleries are Galeria del Quilòmetre and Galeria dels Perduts. Most of these long passages are flooded by brackish phreatic waters and the large accumulation of boulders constantly force cavers to enter and leave the water. Interspersed among those main galleries are labyrinths of smaller passages. The underwater sector this is a massive assemblage of flooded galleries and some breakdown chambers that can be divided

into two areas depending on the passage directions. The first one is on the east side of the cave; its passages reach outstanding lengths and head in northeast-southwest direction. The second is located to the south and consists of shorter passageways extending in variable directions. This sector shows zones where the galleries are totally covered by corrosion features and other zones beautifully decorated with a wide range of speleothems.

Sector F includes a network of small interconnected passages, normally located at the cave's upper level. In spite of the fact that this sector is above the lower maze (Laberint Inferior) of Noves Extensions, it has not been possible to link them so far. Areas with corrosion patterns alternate with others where a wide range of speleothems have been deposited.

Sector del Clypeaster is a network of maze-like galleries located not only at the water table level but also at the upper one. A variety of solutional sculpturing covers the walls, having a great scarcity of speleothems. Additionally, it is possible to find some medium-sized breakdown chambers interspersed. Generally, these chambers are floored with large boulders, covered thin flowstone layers that are cracked from boulder subsidence. Galeria del Mig Quilòmetre is highlighted as a paradigm of conspicuous solutional features (Fig. 3). This 500m-long passageway, though devoid of speleothems, is impressively affected by outstanding corrosion processes; the floor, roof and walls are covered by massive spongework morphologies.

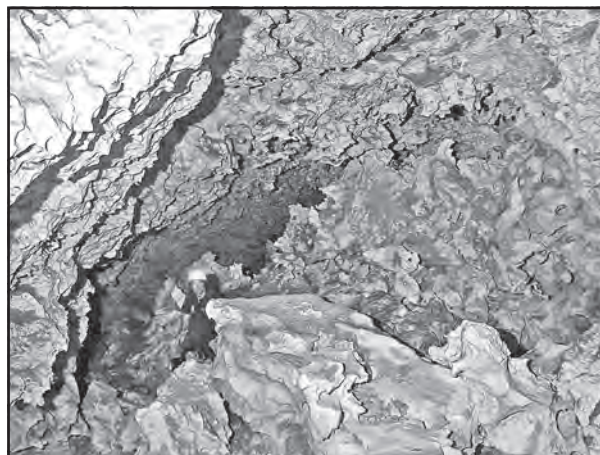

Figure 3: Massive spongework that covers the roof, walls and floor of Galeria del Mig Quilòmetre.

Sector del Tragus is made up mostly of several long rectilinear galleries that run relatively parallel from southwest to northeast, situated both at upper and lower levels. Galeria del Tragus and Galeria del GELL are large

and spectacular. Some of those are close to one kilometer in length, being structurally controlled by major joints (Fig. 4). The wide variety of solutional morphologies and speleothems of this sector is quite remarkable, especially the notable accumulation of moonmilk that covers roof and walls. In addition to phreatic pools, there are upper levels with large freshwater gourls in well-decorated passages. To the southwest is a small area, Sector Nord, characterized by tight and low-roofed galleries that form an intricate maze. The total surveyed development of the cave currently exceeds 59,000 m.

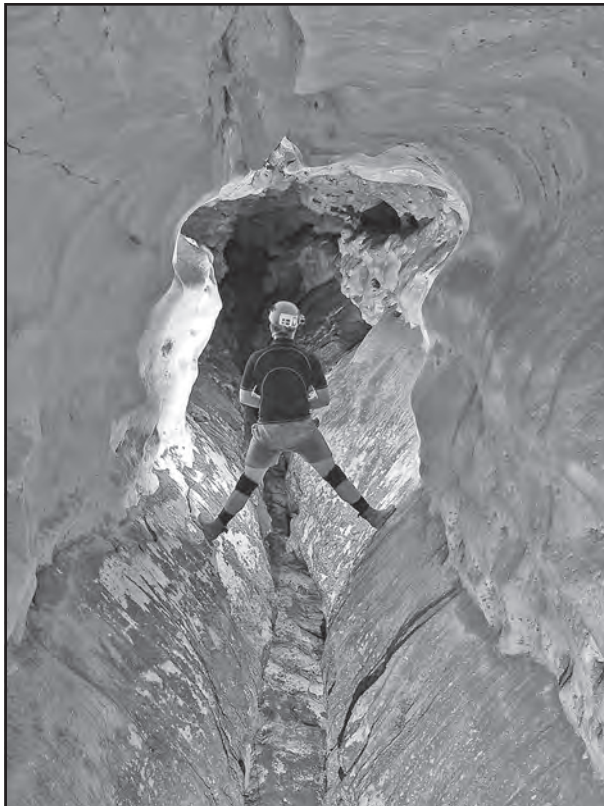

Figure 4: Cross-section of a structurally controlled passage in the upper level of the cave. The joint controlling the passage is clearly seen in its ceiling and corrosion forms can be distinguished at the back of the photo. The upper third of the gallery shows the smoothness of dissolutional morphologies.

3. Speleothems

The importance of the cave is not only related to its surveyed extent, but also for the remarkable richness, astonishing variety, and beauty of its speleothems (Merino, 2007a, 2007b, 2008). Generally speaking, speleothems are distributed throughout the cave. Common dripping water speleothems, stalactites, stalagmites, columns, and colorful and long draperies decorate many passages. Moreover, there are splendid soda straws forests, some of them of

considerable length. Among seeping water speleothems, botryoidal speleothems are well represented, as well as abundant clusters of filamental and vermiform helictites that cover long stretches of passage walls, floors, columns, and stalactites. In the upper level passages it is possible to find long and deep gourls (Fig. 5) along with shallow ponds filled with freshwater, whose walls are completely lined with calcite macrocrystals. This environment is where it is likely to find a variety of shelfstones, like crescent and tiered shelfstone, the coke table type being one of the most outstanding; some of them reach 1 m in diameter. Large cave cups are located in shallow ponds, while medium to small cups occur in deeper ponds. The cave contains examples of other types of speleothems like cave pearls, coral towers, conulites, bird-bath conulites, massive flowstones, candlesticks, cave rims, cave bubbles, septaria, vermiculations, cave cones, gypsum fibrous speleothems, cave flowers, frostwork, cave rafts, etc.

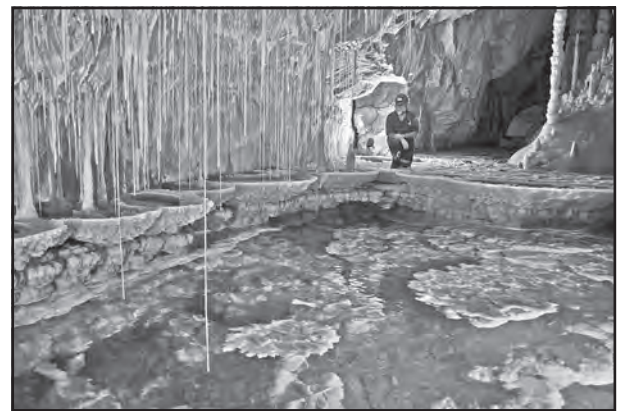

Figure 5: Impressive gour ringed by shelfstones.

One of the most crucial aspects of the Cova des Pas de Vallgornera is the presence of phreatic speleothems. They have been found at or above the surface of the brackish pools that exist throughout the cave. These crystalline overgrowths can be aragonitic or calcitic and, as horizontal bands of speleothems, they record former Mediterranean sea stands corresponding to interglacial periods. Among those speleothems, a smooth yellowish aragonitic band, precipitated at the oscillation range of the current brackish water table, rings the walls of the pools found all along the Sector Antic and Noves Extensions passages and created war-club stalactites where deposited over the tips of pre-existing stalactites. The age of these phreatic aragonite overgrowths is clearly post-glacial, as established by recent Th/U datings (Tuccimei et al., 2008).

Besides the Holocene phreatic speleothems, several crystallization bands are present above the current water

table. A tree-shaped macrocrystalline calcite overgrowth cover stalactites, stalagmites and columns recording a former sea level 2.6 m above the present one (Fig. 6); furthermore, a thinner phreatic crystallization band can be identified at a height of 1.35 m. Both Mediterranean sea paleolevels have been Th/U dated (Bogdan Onac, pers. comm.; Pazzelli, 1999) yielding ages of 120 ka and 81 ka BP respectively, and correspond to MIS substages 5e and 5a. Finally, a rough band of calcite phreatic crystallizations has been located in the Sector Antic, 6.8 m above the current sea level, whose chronology backs presumably to the Middle Pleistocene.



Figure 6: Marked Mediterranean sea paleolevel recorded by phreatic calcite macrocrystals growing around pre-existing column at about 2.6 m above the current water table.

4. Morphological Features and Sediments

The existing morphologies in the cave are varied, drawing particular attention to corrosion features produced in phreatic conditions. The highly aggressive waters have caused a wide range of specific forms that are very well represented in the cave (Merino, 2007a, 2008). Among them, attention should be focused on spongework located in many areas of the cave, above and below the water level. Some galleries are totally surrounded by this particular dissolution feature, with Galeria del Mig Quilòmetre (Sector del Clypeaster) an excellent example of this morphology (Fig. 3). Wall pockets of different sizes and

forms are represented all along the maze passages of the Descubriments 2004 series. These are elliptical smooth depressions, but not true scallops, and produce a common morphology on rock surfaces. Solutional pits of vadose origin are found mainly in the upper level galleries, forming cylindrical well-like structures in the floors. The pits, produced by aggressive dripping water, reach a depth up to 4 m, which is quite remarkable if compared to their diameters of no more than 0.12 m.

In spite of the importance of breakdown processes in some parts of the cave, its inner sectors show an irregular network pattern in which southwest-northeast directions predominate. Phreatic passages with vertically elongated cross-sections are common in the upper level of the cave (Fig. 4) as well as in the lower passages of Sector de Gregal. It is perfectly seen on the ceiling of these passages how the joints have determined a structural control on galleries' dissolutional process. Tubular passages have been recognized as well. Their significant semicircular and elliptic cross sections together with their smooth corrosion surfaces, result in a characteristic morphology. Both types of galleries can reach lengths of tens or hundreds of meters.

As for the sediments, special attention should be given to allochthonous infillings found mainly in the Sector del Tragus, Sector Nord and Sector de Gregal. In the former, is a massive and thick accumulation of silt and sandy deposits containing paleontological remains of endemic vertebrates (*Myotragus* sp.). In the latter two, large deposits of reddish mud cover the floors of many passageways. Some of these fine sediments are lined with a thin black deposit, containing manganese and iron that appears to also coat the walls of many galleries. Gravity-emplaced eolianite deposits are found in some spots near Sala que No Té Nom, choking ancient collapse entrances.

5. Final Considerations

Cova des Pas de Vallgornera is a unique site within the endokarst developed in the Upper Miocene reefal limestones that build up the southern and eastern coast of Mallorca Island. Its exceptional morphological assemblage points to a complex speleogenesis, embracing additional mechanisms besides coastal mixing zone dissolution (Ginés et al., 2008b).

As a consequence of the high natural heritage values represented by this subterranean system (Ginés et al., 2008a), the cave is currently managed by Conselleria de Medi Ambient, Govern de les Illes Balears (the Regional Environmental Authority) and was declared a Site of

Community Importance, number ES5310049, belonging to the Natura 2000 Network (European Council Directive 92/43/EEC). Access to the cave is highly restricted to investigations and surveying authorized by the Conselleria de Medi Ambient.

Acknowledgments

The authors would like to thank the members of the following caving clubs for their invaluable help: Grup Espeleològic Llubí, Agrupación Voltors, Grup Espeleològic EST and Grup Nord de Mallorca. In particular Margalida Femenía from the Conselleria de Medi Ambient, Govern Balear must be credited for her involvement in the whole project.

References

- Collignon, M. (1982), Une première des spéléos namurois a Majorque (Espagne). Au Royaume d'Hades. Groupe Spéléo Namur-Ciney, **2**, 15–26.
- Ginés, J., Ginés, A., Merino, A., Mulet, A., and Mulet, G. (2008a), La Cova des Pas de Vallgornera (Llucmajor, Mallorca). Una localitat excepcional des del punt de vista del patrimoni geoespeleològic. V Jornades de Medi Ambient de les Illes Balears, Soc. Hist. Nat. Balears, 59–60.
- Ginés, J., Ginés, A., Fornós, J.J., Gràcia, F., and Merino, A., (2008b), Noves observacions sobre l'espeleogènesi en el Migjorn de Mallorca: Els condicionaments litològics en alguns grans sistemes subterranis litorals. *Endins*, **32**, 49–80.
- Merino, A. (1993), La Cova des Pas de Vallgornera. *Endins*, **19**, 17–23.
- Merino, A. (2000), Nuevas extensiones de la Cova des Pas de Vallgornera (Llucmajor, Mallorca). *Endins*, **23**, 7–21.
- Merino, A. (2007a), Solutional sculpturings and uncommon speleothems found in the Cova des Pas de Vallgornera, Majorca, Spain. *NSS News*, **65** (9), 14–20.
- Merino, A. (2007b), Algunos espeleotemas poco habituales hallados en la Cova des Pas de Vallgornera. Nuevas observaciones. *Endins*, **31**, 111–116.
- Merino, A. (2008), Nueva aportación al conocimiento de los espeleotemas y morfologías existentes en la Cova des Pas des Pas de Vallgornera. *Endins*, **32**, 43–48.
- Merino, A., Mulet, A., and Mulet, G. (2006), La Cova des Pas de Vallgornera: 23 kilómetros de desarrollo topografiado (Llucmajor, Mallorca). *Endins*, **30**, 29–48.
- Merino, A., Mulet, A., Mulet, G., Croix, A., and Gràcia, F. (2007), La Cova des Pas de Vallgornera (Llucmajor, Mallorca): 40 kilómetros de desarrollo topografiado. *Endins*, **31**, 101–110.
- Merino, A., Mulet, A., Mulet, G., Croix, A., and Gràcia, F. (2008), La Cova des Pas de Vallgornera (Llucmajor, Mallorca): Alcanza los 55 kilómetros de desarrollo topográfico. *Endins*, **32**, 33–42.
- Pazzelli, L. (1999) Variazioni del livello del mare nel Mediterraneo occidentale durante il Tardo Pleistocene, misurate attraverso la datazione U/Th di concrezioni freatiche su speleotemi sommersi nelle grotte costiere dell'isola di Mallorca (Spagna). Tesi di Laurea. Università degli Studi "Roma Tre". 114 p. Unpublished.
- Tuccimei, P., Soligo, M., Ginés, J., Ginés, A., Fornós, J.J., Kramers, J., and Villa, I.M. (2008), Speleothem precipitation at the water table of Holocene meteoric-marine mixing zones in Mallorca (Western Mediterranean). Strengths and limitations as palaeoenvironmental and palaeoclimatic archives. *European Geosciences Union, General Assembly 2008. Geophysical Research Abstracts*, **10**, A-02145. 2 p. Wien.

EFFECTS OF CONTINENTAL OVERPRINTING ON CAVE DEVELOPMENT IN EOGENETIC KARST: AN EXAMPLE FROM THE FLORIDA-BAHAMAS PLATFORM

PAUL J. MOORE

University of Florida, Department of Geological Sciences, 241 Williamson Hall, Gainesville, FL 32611

The morphology and size of many caves in Florida are similar to flank margin caves found throughout the Bahamas. Caves in both locations are believed to form as isolated voids along past and present water-table horizons. Recent work from San Salvador Island, Bahamas and north-central Florida suggest large amounts of dissolution results from input of CO₂ at the water table. Mass balance calculations suggest that only 40% of the observed dissolved CaCO₃ in San Salvador water is required to form a flank margin cave when lens hydrodynamics are also considered, and dissolution mechanisms such as the mixing of fresh and saline water are not necessary for their formation. Estimates of dissolution rates are lower in Florida but are still sufficient to generate caves, suggesting that geochemical reactions do not limit cave development. Instead, cave enlargement likely reflects the efficiency of reaction products to be transported away from the locus of cave development. On islands, flank margin cave volumes are limited by specific discharge at the lens edge flushing reaction products to the ocean. In Florida, large hydraulic head results from siliciclastic sediments that clog limestone pores and retard groundwater flow. In this case, high head likely generates sufficient flux along the water table to flush reaction products away from an enlarging void. The similarities that Florida water-table caves share with flank margin caves suggests that mixing dissolution is not required to form large dissolution voids because the mixing of fresh and saline water did not occur across the Florida platform where present-day air-filled caves are located.

1. Introduction

Many caves in Florida are morphologically similar to caves observed in the Bahamas. In both locations, caves are frequently laterally-extensive and vertically-restricted voids with large chambers, blind pockets, and dead-end passages (e.g., Mylroie and Carew, 1990; Florea, 2006). On both platforms, geomorphic and glacio-eustatic evidence suggests these voids are phreatic in origin and develop along water-table horizons both within the platform's interior and along shorelines (e.g., Mylroie and Carew, 1990; Florea et al., 2007). Cave morphology and the high matrix porosity and permeability of the diagenetically-immature limestone (i.e., eogenetic karst, Vacher and Mylroie, 2002) suggests these cave likely formed under diffuse-flow conditions, and thus formed as dissolution chambers and not true conduits. Consequently, they are believed to form with limited connection with the land surface, whereby diffuse recharge to the water table occurs through the epikarst and vertical preferential flow paths, such as narrow fracture trends (Florea, 2006) or along well-developed karstic fissures (Whitaker and Smart, 1997). Cave entrances form when the voids are breached by surface denudation, hillside erosion, or land alteration such as road construction and quarrying.

One primary mechanism believed to drive cave development in these locations is the mixing of water with different

chemical compositions. Bögli (1980) suggested the mixing of vadose and phreatic water at the water table would drive localized limestone dissolution and called this process "mischungskorrosion". In the Bahamas, voids known as banana holes form within the interior, reaching hundreds of m³ in volume and are believed to have developed by mixing of vadose and phreatic water (Harris et al., 1995). Conversely, larger voids, called flank margin caves, can reach thousands of m³ in volume and are believed to have developed along the edge of freshwater lenses primarily from the convergence of two areas of mixing dissolution: "mischungskorrosion" at the water table and mixing of fresh and saline water at the halocline (Plummer, 1975; Mylroie and Carew, 1990). The primary difference between banana holes and flank margin caves is size, which is largely attributed to more dissolution along the lens edge (Mylroie and Carew, 1990). However, recent work on North Andros Island, Bahamas suggests "mischungskorrosion" is not a major driver of dissolution at the water table (Whitaker and Smart, 2007), and work from San Salvador Island, Bahamas suggests mixing of fresh and saline water has only a minor influence on dissolving calcium carbonate (Moore et al., submitted). Instead most dissolution across these islands is controlled primarily by inputs of CO₂ (e.g., Plummer et al., 1976; Ng and Jones, 1995; Whitaker and Smart, 2007; Moore et al., submitted).

In Florida, many large air-filled caves occur at water-table elevations consistent with present-day sea level or align with marine terraces of past sea-level high stands (Florea et al., 2007). These caves reach volumes in excess of thousands of m^3 and likely formed in the absence of mixing of fresh and saline water, since the thickness of fresh ground water where these caves are located can exceed several hundred meters (Miller, 1986). In this paper, I explore the similarities between caves that develop on San Salvador Island and Florida, along with water chemistry from both locations, to suggest that cave development is largely driven by inputs of CO_2 , and that cave size is more a function of transporting dissolution reaction products away from the locus of cave development and not the result of the convergence of multiple geochemical processes driving dissolution.

2. Background

The Bahamian Archipelago is a long series of carbonate islands and shallow banks located along the eastern margin of Florida (Fig. 1). Islands in the northwestern portion of the archipelago are isolated landmasses located on two large

platforms, Little Bahama Bank and Great Bahama Bank. To the southeast, the archipelago consists of small, isolated platforms that are capped by islands that cover most of the platform area. The banks are predominately shallow-water marine facies that range in thickness from 5 to 10 km, and the islands are composed of variably-cemented Holocene and mid-to-late Pleistocene carbonate sediments of subtidal, reef, beach, and dune facies that reach up to about 60 meters above present sea level (masl) (Carew and Mylroie, 1997). Although shallow-water carbonates are the dominant facies across the Bahama banks, deep core borings have revealed deeper-water facies along the prograding platform margin (Melim, 1996). The Bahamas have remained isolated from continental sedimentation because the Gulf Stream current flows through the Straits of Florida and transports siliciclastic sediment reaching the eastern edge of the Florida platform north along the North American shoreline (e.g., Snyder et al., 1990).

During the Paleogene, the carbonate platform of Florida had a geologic setting very similar to the Great Bahama

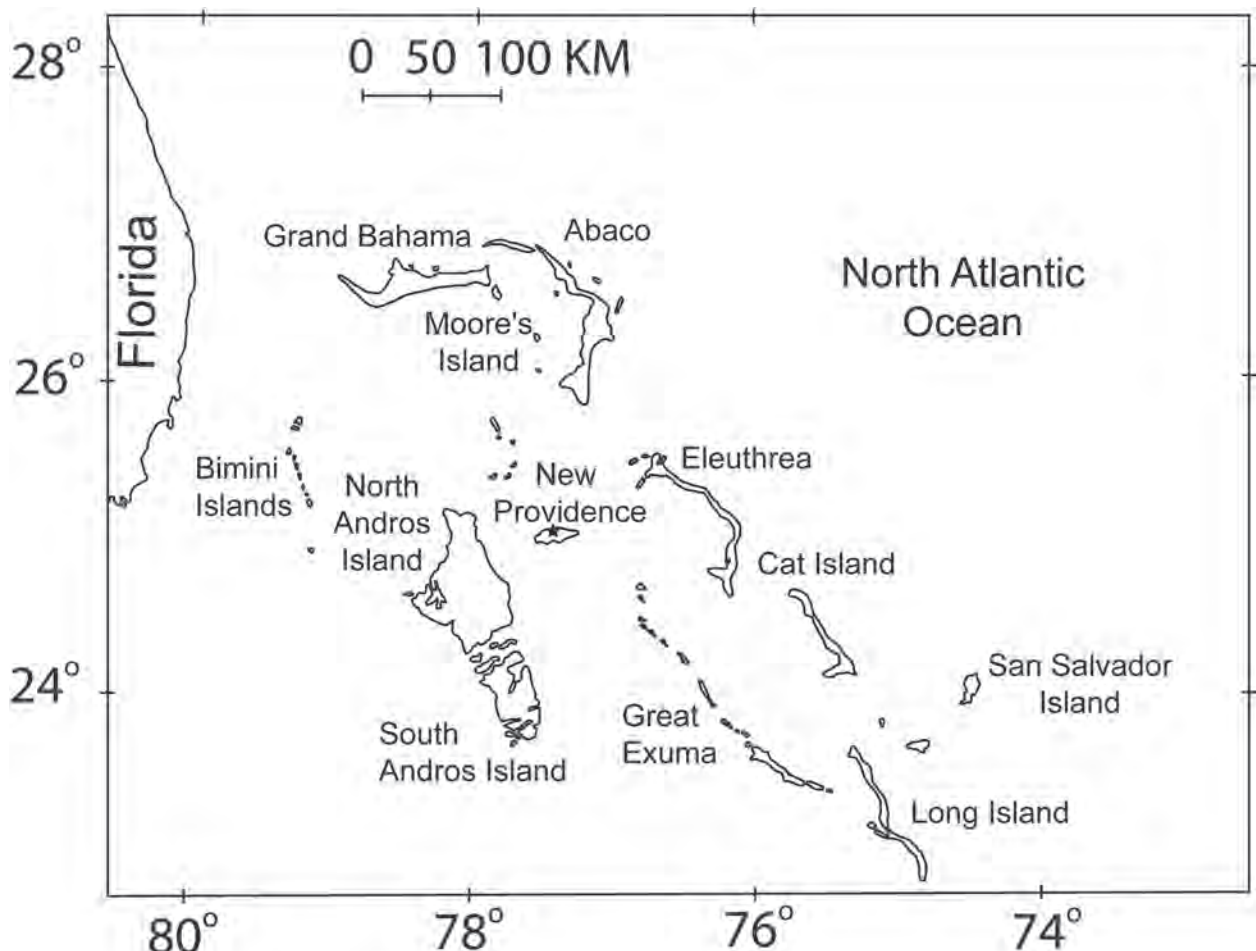

Figure 1: Map of the western Mediterranean with the location of the Mallorca Island.

Bank today. Although both platforms have similar histories of carbonate deposition and climate, the Florida platform became covered with siliciclastic sediments starting in the Late Oligocene (Scott, 1988). Prior to this time, primary deposition was carbonate sediments in a shallow-marine environment. Only minor amounts of siliciclastic sediment reached the platform due to a trench, called the Georgia Channel System, that separated the platform from the North American continent by a marine current that transported sediments away from the platform (Lane, 1986). The current occupied the channel until global cooling in the Late Oligocene resulted in a major sea-level low stand (Randazzo, 1997). Following the sea-level low stand, increased erosion eventually filled in the channel system and blocked the current from reoccupying the channel when sea level rose again (Scott, 1997). Siliciclastic sediments covered all the Paleogene carbonates by the Late Miocene to early Pliocene, and are collectively known as the Hawthorn Group (Scott, 1988). Deposition of the Hawthorn sediments varies in thickness across the platform because of highs and lows on the Paleogene carbonate surface. In north-central Florida, any Hawthorn sediment was reworked and eventually removed during rising sea level in the Pleistocene, leaving a portion of the Floridan aquifer unconfined.

3. Controls on Dissolution and Cave Development on San Salvador Island, Bahamas

Recent work on water chemistry on San Salvador Island, Bahamas showed most of the Ca^{2+} in excess expected from seawater dilution occurred in low salinity water with P_{CO_2} values up to 2 orders of magnitude above atmosphere (Moore et al., submitted). These concentrations of Ca^{2+} , up to 48 times over values expected from seawater, suggest dissolution is controlled primarily by inputs of CO_2 to freshwater, and mixing of fresh and saline water had only a minor influence on dissolution. Moore et al (submitted) suggested that the development of flank margin caves and banana holes likely form by dissolution driven by discrete inputs of CO_2 to freshwater coupled with the hydrodynamics of the freshwater lens. Using the dimensions of a mapped flank margin caves and freshwater lens hydrodynamics, they estimated an annual dissolution rate of about $270 \text{ m}^3/\text{km}^2$ was required to produce a cave with a volume of $1,200 \text{ m}^3$ in 10 ky. The amount of dissolved CaCO_3 needed to generate the dissolution rate required only 40% of the average amount of mineral-derived Ca^{2+} found in low salinity water from San Salvador Island. Moore et al. (submitted) suggested that flank margin caves are larger than banana holes because specific discharge is greater at the lens edge compared to at the water table within the

island's interior, which rapidly flushed reaction products to the ocean. The smaller banana holes likely reflect lower flow velocities at the water table in the interior portions of the lens, which may allow some of the reaction products to reprecipitate as cements (e.g., Vacher and Mylroie, 2002).

4. Influences of Confining Unit and Cave Development in Florida

In Florida, many air-filled caves occur within the interior of the platform and are believed to form along both past and present water-table horizons (Florea et al., 2007). Although these caves are similar in size and shape to flank margin caves (Florea, 2006), they formed in the absence of mixing of fresh and saline water (Fig. 2). Their development may support the observation of Moore et al. (submitted) that groundwater hydrodynamics, and not the mechanism of dissolution is the critical factor for the development of water-table caves in eogenetic karst. For example, Moore et al. (submitted) estimated dissolution rates on the order of $270 \text{ m}^3/\text{km}^2/\text{yr}$ were required to generate a flank margin cave, but suggested the critical factor for cave development was specific discharge at the lens edge (e.g., Vacher et al., 1990). Recent work on groundwater chemistry in an unconfined section of the Floridan aquifer suggests that dissolution at the water table can result in an annual removal 100 to 250 m^3 of limestone over an area ranging from 30 to 70 km^2 , or about $3.5 \text{ m}^3/\text{km}^2$ (Ritorto et al., in press). This suggests that this area would experience about $35000 \text{ m}^3/\text{km}^2$ of limestone removal in 10 ky. In many cases, dissolution will be distributed across the water table resulting in thin horizontal voids (e.g., Fig. 2 in Florea et al., 2007); however, the development of large water-table caves (e.g., Florea, 2006) may reflect dissolution being controlled by rapid and preferential removal of reaction products, similar to processes suggested to be occurring in the Bahamas (Moore et al., submitted).

The removal of reaction products from the water table in Florida can be attributed to high hydraulic head generated by the deposition of Hawthorn sediments across the platform. As these less permeable sediments filter into the limestone pore spaces, they retard groundwater flow, generate high hydraulic head, and produce thick zones of fresh groundwater much greater than observed on other platforms (e.g., Back and Hanshaw, 1970). For example, the hydraulic gradient in Florida is on the order of about 1 m/km with zones of fresh groundwater that exceed 700 m in some areas (Miller, 1986). Conversely, hydraulic gradients in the Bahamas range from an average of about 0.05 m/km on North Andros Island to as low as 0.005 m/km on San Salvador Island, and freshwater lenses are typically only

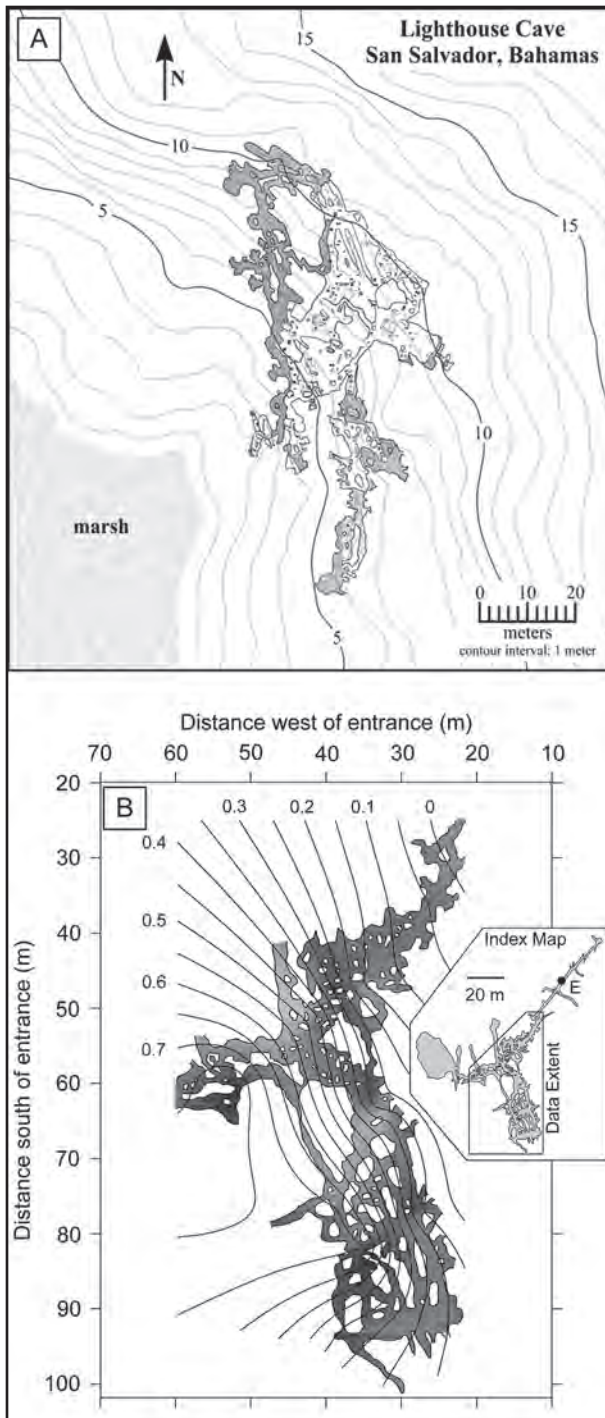

Figure 2: Survey of the cave with the main sectors identified.

tens of meters thick (Davis and Johnson, 1989; Whitaker and Smart, 1997). Despite these low gradients, lens hydrodynamics are believed to be sufficient in driving cave development on these islands (Moore et al., submitted). Although estimates of dissolution rates are lower in Florida, large caves may develop in thousands of years provided dissolution is focused and reaction products are flushed

away from the locus of cave development, which is likely given the high hydraulic head generated in Florida.

Acknowledgements

Thanks to Jason Gulley for lively discussions about cave genesis and reviewing an earlier draft of this write-up.

References

- Back, W., and Hanshaw, B.B. (1970), Comparison of chemical hydrology of the carbonate peninsulas of Florida and Yucatan. *Journal of Hydrology*, **10**, p. 330–368.
- Bögli, A. (1980), *Karst hydrology and physical speleology*. Springer-Verlag, New York, 284 p.
- Carew, J.L., and Mylroie, J.E. (1997), Geology of the Bahamas. Chapter 3 in *Geology and Hydrogeology of Carbonate Islands*, Vacher, H.L., and Quinn, T.M. (Eds.), *Developments in Sedimentology* 54, p. 91–139.
- Davis, R.L., and Johnson, J., C.R. (1989), Karst hydrology of San Salvador. *Proceedings of the Fourth Symposium on the Geology of the Bahamas*, Fort Lauderdale, p. 118–135.
- Florea, L.J. (2006), *The Karst of West Central Florida*. Ph.D. Dissertation, University of South Florida, Tampa, 564 p.
- Florea, L.J., Vacher, H.L., Donahue, B., and Naar, D. (2007), Quaternary cave levels in peninsular Florida. *Quaternary Science Reviews*, **26**, p. 1344–1361.
- Harris, J.G., Mylroie, J.E., and Carew, J.L. (1995), Banana holes: unique karst features of the Bahamas. *Carbonates and Evaporites*, **10**, p. 215–224.
- Lane, E. (1986), *Karst in Florida*. Florida Geological Survey Special Report 29, 100 p.
- Melim, L.A. (1996), Limitation on lowstand meteoric diagenesis in the Pliocene-Pleistocene of Florida and Great Bahama Bank: Implications for eustatic sea-level models. *Geology*, **24**, p. 893–896.
- Miller, J.A. (1986), Hydrogeologic framework of the Floridan aquifer system in Florida and parts of Georgia, Alabama, and South Carolina. U.S. Geological Survey Professional Paper 1403-B, 91 p.

- Moore, P.J., Martin, J.B., and Mylroie, J.E. (submitted), Rapid generation of macroporosity on carbonate islands: The flank margin cave hypothesis revisited. *Journal of Sedimentary Research*
- Mylroie, J.E., and Carew, J.L. (1990), The flank margin model for dissolution cave development in carbonate platforms. *Earth Surface Processes and Landforms*, **15**, p. 413–424.
- Ng, K.-C., and Jones, B. (1995), Hydrogeochemistry of Grand Cayman, British West Indies; implications for carbonate diagenetic studies. *Journal of Hydrology*, **164**, p. 193–216.
- Plummer, L.N. (1975), Mixing of sea water with calcium carbonate ground water. Chapter 10 in *Quantitative Studies in the Geological Sciences*, Whitten, E.H.T. (Ed.), Geological Society of America Memoir 142, p. 219–238.
- Plummer, L.N., Vacher, H.L., Mackenzie, F.T., Bricker, O.P., and Land, L.S. (1976), Hydrogeochemistry of Bermuda; a case history of ground-water diagenesis of biocalcarenes. *Geological Society of America Bulletin*, **87**, p. 1301–1316.
- Randazzo, A.F. (1997), The Sedimentary Platform of Florida: Mesozoic to Cenozoic. Chapter 4 in *The Geology of Florida*, Randazzo, A.F., and Jones, D.S. (Eds.), University Press of Florida, Gainesville, p. 39–56.
- Ritorto, M., Sreaton, E.J., Martin, J.B., and Moore, P.J. (in press), Magnitudes and Chemical Effects of Diffuse and Focused Recharge in an Eogenetic Karst Aquifer: An Example from the Unconfined Floridan Aquifer. *Hydrogeology Journal*.
- Roth, M. J. (2004), Inventory and geometric analysis of flank margin caves of the Bahamas. Master's thesis, Mississippi State University, 117 p.
- Scott, T.M. (1988), The Lithostratigraphy of the Hawthorn Group (Miocene) of Florida. *Florida Geological Survey Bulletin* 59, 148 p.
- Scott, T.M. (1997), Miocene to Holocene History of Florida. Chapter 5 in *The Geology of Florida*, Randazzo, A.F., and Jones, D.S. (Eds.), University Press of Florida, Gainesville, p. 57–68.
- Snyder, S.W., Hine, A.C., and Riggs, S.R. (1990), The seismic stratigraphic record of shifting Gulf Stream flow paths in response to Miocene glacioeustasy: Implications for phosphogenesis along the North Carolina continental margin. Chapter 7 in *Neogene to modern phosphorites*, Burnett, W.C., and Riggs, S.R. (Eds.), Cambridge University Press, Cambridge, p. 396–423.
- Vacher, H.L., Bengtsson, T.O., and Plummer, L.N. (1990), Hydrology of meteoric diagenesis; residence time of meteoric ground water in island fresh-water lenses with application to aragonite-calcite stabilization rate in Bermuda. *Geological Society of America Bulletin*, **102**, p. 223–232.
- Vacher, H.L., and Mylroie, J.E. (2002), Eogenetic karst from the perspective of an equivalent porous medium. *Carbonates and Evaporates*, **17**, p. 182–196.
- Whitaker, F.F., and Smart, P.L. (1997), Climatic control of hydraulic conductivity of Bahamian limestones. *Ground Water*, **35**, p. 859–868.
- Whitaker, F.F., and Smart, P.L. (2007), Geochemistry of meteoric diagenesis in carbonate islands of the northern Bahamas; 2, Geochemical modelling and budgeting of diagenesis. *Hydrological Processes*, **21**, p. 967–982.

FLANK MARGIN CAVE DEVELOPMENT AS SYNDEPOSITIONAL CAVES: EXAMPLES FROM THE BAHAMAS

JOHN E. MYLROIE, JOAN R. MYLROIE

Department of Geosciences, Mississippi State University, Mississippi State, MS 39762 USA mylroie@geosci.msstate.edu

In 1964 Joe Jennings introduced the term *syngenetic karst* to describe karst formation occurring in carbonate sands as those sands consolidated. The term “consolidation” was somewhat open-ended and Jennings treated it as any carbonate rock undergoing initial lithification and early diagenesis, a rock category carbonate geologists now call eogenetic. Joe Jennings’ definition was based on work in eolian calcarenites of southern and western Australia. His syngenetic karst term was subsequently reviewed in 2007 by Australian karst scientists Ken Grimes and Susan White, in conjunction with the co-authors, to create a hierarchy of caves based on age and place in the diagenetic cycle. They stated that the earliest cave genesis is *constructional cave* formation, as in tufa caves and reef macro-porosity, which occurs simultaneously with carbonate rock deposition but without *in situ* dissolution. *Syngenetic caves*, according to their view, form in two ways: by dissolution in unlithified and still depositing sediments, as *syndepositional caves*; and by dissolution in lithified but diagenetically-immature carbonate rocks, as *eogenetic caves*. With time, carbonate burial results in diagenetic maturity, and creates *mesogenetic caves* produced, by definition, through hypogenic processes. Re-exposure of diagenetically-mature carbonates on the earth’s surface results in the most common cave type, *telogenetic caves*. *Marble caves* form in metamorphosed carbonates derived from mesogenetic or telogenetic conditions.

Work in the Late Pleistocene carbonates of the Bahamas has demonstrated that syndepositional caves exist. Altar Cave and Chinese Fire Drill Cave, San Salvador Island, and A-Survey Cave, New Providence Island, are all flank margin caves developed in carbonate rocks of the Cockburn Town Member of the Grotto Beach Formation. These rocks were deposited during the last interglacial sea-level highstand (MIS 5e) from 131 to 119 ka. The Bahamas are tectonically stable, and for dry phreatic caves to exist in Cockburn Town Member carbonate rocks requires that the fresh-water lens subsequently invaded these carbonates on the same sea-level highstand that deposited the carbonate sediments. The carbonate units involved are progradational, they resulted from excess carbonate sediment supply infilling lagoons, allowing beach, back beach, and dune carbonates to prograde into the lagoonal depositional environment. The fresh-water lens then advanced into this new subaerial environment, and dissolutional hydrology was established in the lens margin. The carbonate sediments were precipitated, transported and deposited, then flank margin caves were dissolved within them, in a time span of less than 12,000 years. Cementation must have been sufficient to allow voids to withstand collapse, yet dissolution occurred in the very same environment where carbonate deposition was on-going. We consider this situation to be an example of syndepositional cave development.

1. Introduction

How quickly can karst, or dissolutional, caves form in carbonate rock? A cave must be younger than the carbonate rock that surrounds it, but that rock can be thousands to millions to billions of years old; the cave could have formed at any time after the deposition of the rock. The Adirondack Mountains of New York contain outcrops of 1 billion year old Grenville marble; this marble contains caves developed after the end of the last glaciation, so the caves are only ~10,000 years old (Mylroie and Mylroie, 1990). There are five orders of magnitude time difference between the age of the rock and the age of the caves. At the other extreme are

caves that develop almost immediately after the carbonate rock has been deposited. As a group, these caves are called *syngenetic caves*, a term referring to the phrase *syngenetic karst* that was introduced by Joe Jennings as early as 1964 (Jennings, 1968). An important aspect of syngenetic cave development for understanding speleogenesis is that it puts a lower limit on the time for dissolution to advance from initial porosity to the production of macroscopic voids, or caves.

Syngenetic karst, as introduced by Joe Jennings, is a very inexact term. Jennings used the term “consolidation”, not

“deposition” in his definition (Jennings, 1968, p. 41): “To a certain degree karst processes have gone on concurrently with the consolidation of calcareous shell sand into aeolian calcarenite, i.e. the karst is partially ‘syngenetic.’” Jennings was referring to fieldwork done by himself and others in the Quaternary eolian calcarenites of southern and western Australia, rocks much younger than those found in North America or Europe where most western karst literature was based. White et al. (2007) discuss how the term was derived, indicating that it came to be interpreted as caves formed immediately after rock deposition, whereas Jennings (1968) felt that it covered a wider time range, from deposition to early diagenetic maturity of the carbonate sediments involved. Utilizing the three main rock diagenetic stages of Choquette and Prey (1970, p. 215), “the time of early burial as *eogenetic*, the time of deeper burial as *mesogenetic*, and the late stage associated with erosion of long-buried carbonates as *telogenetic*”, dissolutional caves can be defined based on the diagenetic stage of the rock hosting them. The syngenetic karst of Jennings (1968) is actually occurring in rocks in the eogenetic stage. The diagenetic stages of Choquette and Pray (1970) have broad application to cave and karst processes. Vacher and Mylroie (2002, p. 183) defined eogenetic karst as: “we use the term *eogenetic karst* for the land surface evolving on, and the pore system developing in, rocks undergoing eogenetic, meteoric diagenesis. In contrast, *telogenetic karst* is the karst developed on and within ancient rocks that are exposed after the porosity reduction of burial diagenesis.” As mesogenetic rocks are by definition not exposed on the earth’s surface, Vacher and Mylroie (2002) did not address them, but certain cave types, such as the confined hypogenic caves of Klimchouk (2007), are obligatory to the mesogenetic environment.

2. Caves Classified by Diagenetic Stage

White et al. (2007) sorted through the terminology and created the following classification of caves:

1. **Constructional caves:** void production occurs simultaneously with carbonate rock deposition but without *in situ* dissolution.

2. **Syngenetic caves:** dissolution to produce cave voids in carbonate rocks that have not reached diagenetic maturity. Subdivided into two categories:

A. **Syndeositional caves:** caves formed by dissolution while the carbonate sedimentary unit containing the caves is still being deposited.

B. **Eogenetic caves:** caves formed in carbonate rocks after deposition is complete, but before diagenetic maturity has been achieved by deep burial.

3. **Mesogenetic caves:** caves formed in the deep burial, hypogene diagenetic environment.

4. **Telogenetic caves:** caves formed in diagenetically-mature carbonates at or near the earth’s surface.

5. **Marble caves:** caves formed in metamorphosed carbonate rock.

There are numerous cave classifications, does the karst world really need another one? The White et al. (2007) classification is one based on a consistent application of the stages of deposition-diagenesis-metamorphosis of the carbonate rock hosting a cave. It is clear from an overall view of the various major cave types found around the world that the rock diagenetic history is important in determining what type of cave develops, from flank margin caves (Mylroie and Mylroie, 2007) to confined hypogenic caves (Klimchouk, 2007), to epigenic stream caves (Palmer, 1991).

Examples of constructional caves would be tufa caves, where tufa deposition at cliff overhangs encloses a space (e.g. Bögli, 1980, Figure 13.15). In this case, one could argue philosophically that the void was always there and the rock just enclosed it. Another example is the enclosing of macroscopic voids during the growth of coral reefs. In both cases, there has been no *in situ* dissolution to excavate a void; open space has been enclosed by carbonate deposition. Constructional caves are therefore not true karst caves.

To demonstrate that syndeositional caves have formed requires careful fieldwork, so field criteria and examples are discussed in detail below. Because the term syngenetic karst is historic and pervasive in the karst literature, syngenetic cave has been retained as the overall category for caves developed in new or diagenetically-immature carbonate rocks. Eogenetic cave is a term that can be used in environments where syndeositional caves may also be occurring, such as in the Bahama Islands, so that distinctions can be made between the two cave types. Syndeositional cave development assumes enough early cementation, or cohesiveness of the carbonate sediment, such that voids produced by dissolution can withstand forces that would cause void collapse. Through time, after carbonate deposition ceases, continued cementation and increasing diagenetic maturity allow the cave walls and ceilings to

become strong enough that the cave can persist in the eogenetic realm.

The mesogenetic environment is by definition cutoff from the surface and shallow subsurface hydrologic realm. Caves that form there by dissolution are developing in the hypogene environment, and so form only hypogenic caves, including the confined hypogenic caves of Klimchouk (2007). The telogenetic environment allows cave development by surface and shallow subsurface processes, the epigenetic caves of Palmer (1991). Because telogenetic rocks have moved from their initial environment of deposition to eogenetic conditions and on through the mesogenetic environment before reaching the telogenetic environment, they carry a signature from all their previous environments. Included among these signatures can be caves formed in the syndepositional, eogenetic and mesogenetic realms (Myloie and Myloie, 2007; 2008; Klimchouk, 2007). Marble caves form in metamorphosed carbonates, which can be considered to be the ultimate diagenetic step. The obliteration of primary features, and many secondary features, by metamorphosis causes cave patterns in marbles to at times be quite different than those found in telogenetic carbonates in the same hydrologic environment.

3. Syndepositional Caves

Syndepositional caves, after speleogenesis, eventually make the relatively quick and short translation into the eogenetic

realm, once carbonate deposition in their immediate vicinity ceases. Whether they and their eogenetic cave relatives survive burial into the mesogenetic environment (and perhaps exhumation onward to the telogenetic environment) is debatable. It is also difficult to define criteria that would allow caves to be uniquely identified as syndepositional at the much larger time and distance of the mesogenetic and telogenetic setting. Therefore, to demonstrate that syndepositional caves exist requires examination of very young carbonate settings, where boundary conditions can be placed on cave origin. Such conditions exist in the Bahamian Archipelago, where the carbonates are young, generally less than 500 ka, cave development is restricted to glacioeustatic sea-level highstands, and some islands are small (Myloie and Myloie, 2007). These constraints on time and space allow inspection of the conditions necessary to create syndepositional caves.

On carbonate islands, the largest type of caves to form are the flank margin caves, which develop in the distal margin of a Ghyben-Herzberg-Dupuit fresh-water lens, under the flank of the enclosing landmass (hence the designation “flank margin cave”). The caves result as the synergistic outcome of three factors (Myloie and Myloie, 2007). 1) Mixing of vadose fresh water with phreatic fresh water at the top of the lens, and mixing with marine phreatic water below and adjacent to the lens; at the lens margin, these two

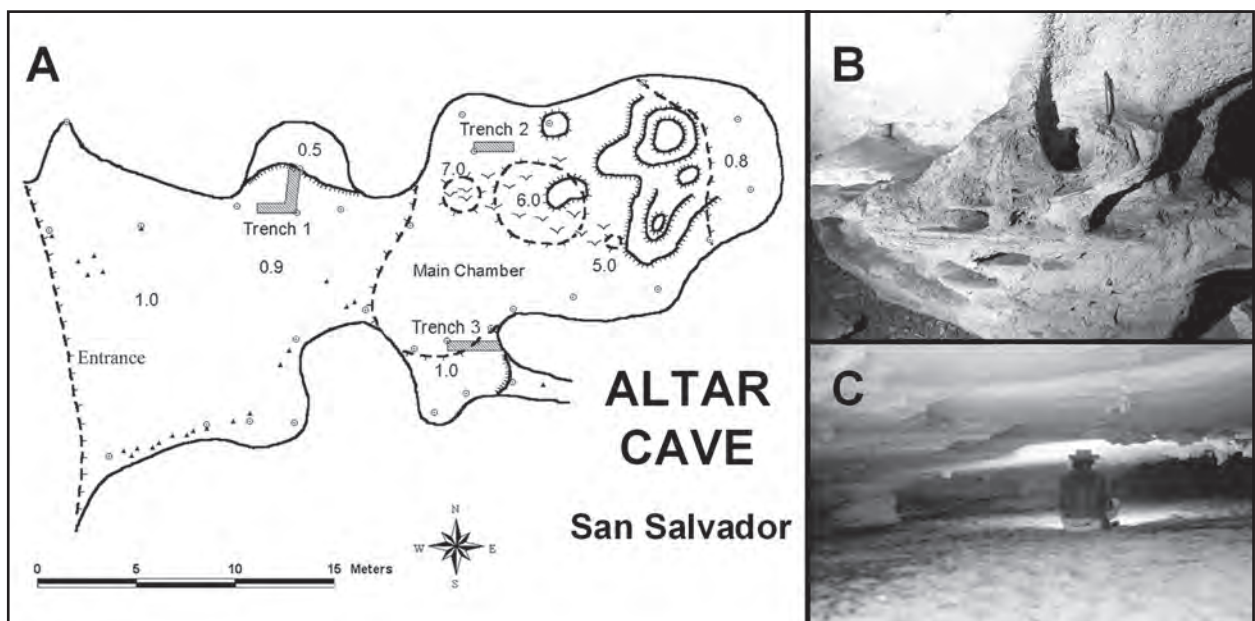

Figure 1: Altar Cave, San Salvador Island, Bahamas. (A) Map of Altar Cave (modified from Florea et al., 2004). Numbers on the floor of the cave are ceiling heights in meters. (B) Speleogens in the wall of Altar cave, at the location of “trench 3” on the cave map shown in A. Pencil in upper right is 15 cm long for scale. (C) Entrance passage of Altar Cave, the site marked “trench 1” on the cave map in A is to the left of the seated figure.

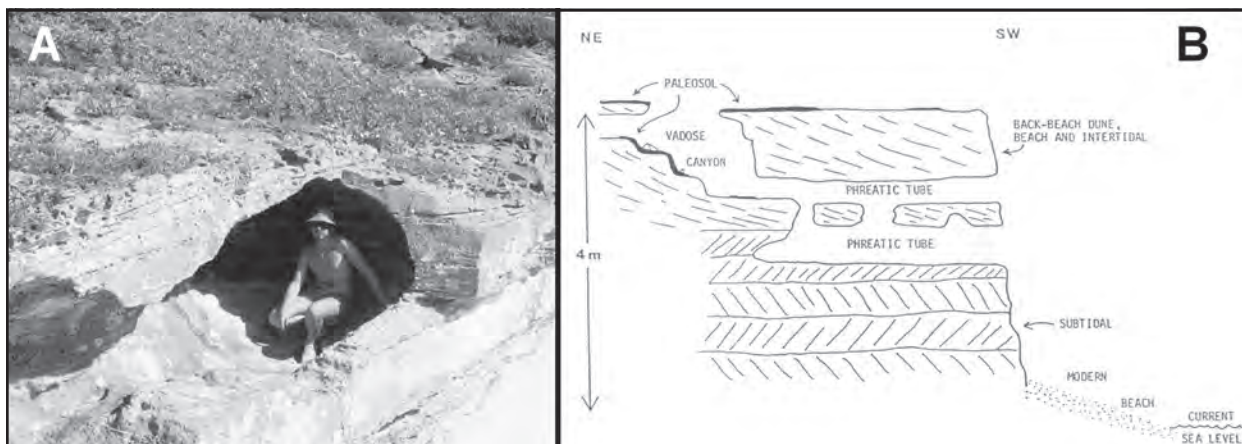

Figure 2: Chinese Fire Drill Cave, San Salvador Island, Bahamas. (A) Phreatic passages of the cave exposed by wave erosion, in beach facies immediately above subtidal facies containing herringbone cross bedding. (B) Diagrammatic cross section of the cave showing development in subtidal facies containing herringbone cross bedding.

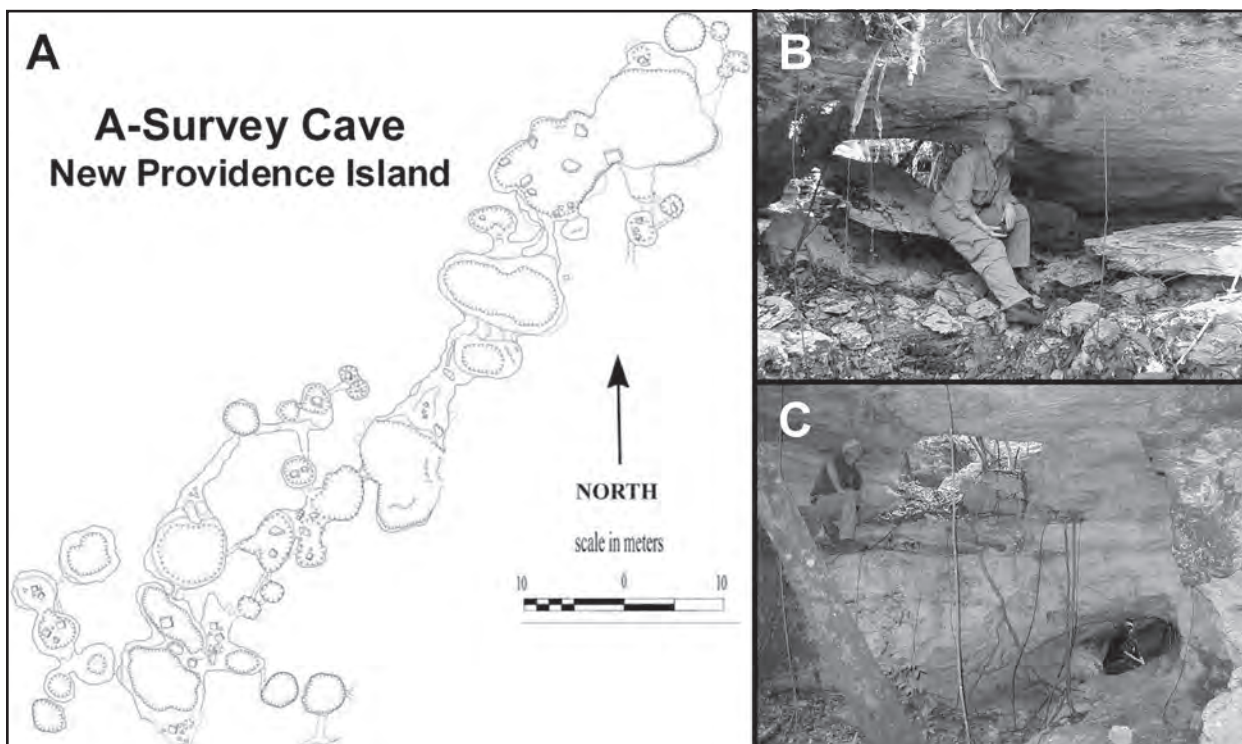

Figure 3: A-Survey Cave, New Providence Island, Bahamas. (A) Map of A-Survey Cave, a series of interconnected chambers (modified from Mylroie et al., 2008). (B) Phreatic chamber of A-Survey Cave, truncated by collapse. (C) Large chamber in A-Survey Cave, with passages both high and low.

dissolutionally-active sites are superimposed. 2) Collection of organics at the top and bottom of the lens promotes organic decay, with CO₂ and even H₂S production to drive dissolution; again, these two dissolutionally-active sites are superimposed at the lens margin. 3) Flow velocities at the lens margin are the greatest within the lens, moving reactants in and products out rapidly to promote continued dissolution. As a result, flank margin caves form very fast. In the Bahamas dry flank margin caves are found from 1 to 6 m above modern sea level. As a result of the tectonic

stability of the Bahamas, these caves must have formed by a glacioeustatic sea level higher than today. Only the Marine Isotope Substage 5e (MIS 5e), or last interglacial, which reached 6 m above modern sea level, qualifies (Carew and Mylroie, 1995a). That highstand lasted for 12,000 years, from 131 ka to 119 ka (Chen et al., 1991), so flank margin caves with tens of thousands of cubic meters of void space developed in that limited time span. The fresh-water lens margin is a fast-acting speleogenetic environment of immense power.

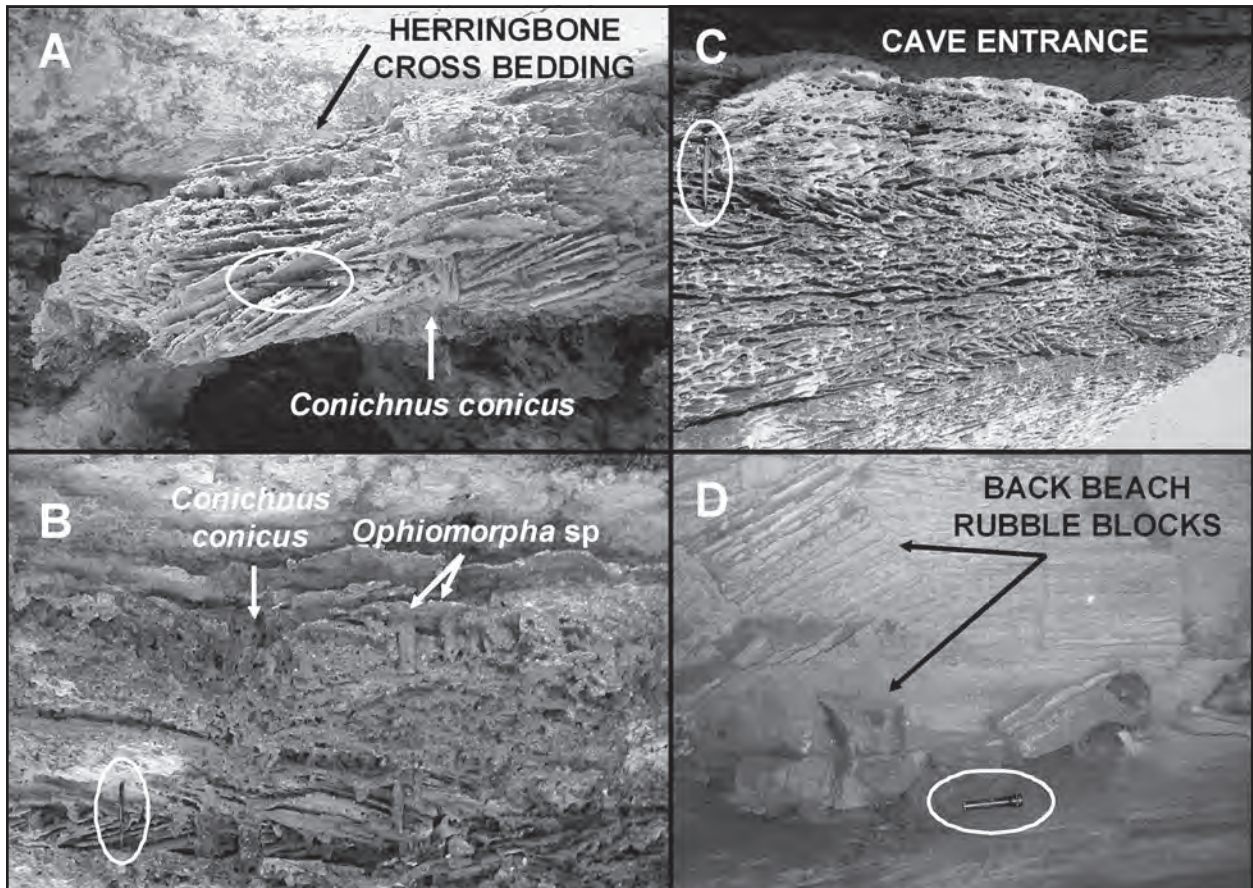

Figure 4: Detail of bedrock walls of Bahamian syndeositional caves, showing numerous subtidal indicators. Pencil in oval in images A-C is 15 cm long, the flashlight in D is 15 cm long, for scale. (A) Cave wall in A-Survey Cave. Herringbone cross bedding, a subtidal indicator, and the subtidal trace fossil *Conichnus conicus*, the trace left by a sea anemone as it moves upward through sand as the sands cover it, are present. (B) Cave wall in A-Survey Cave. Herringbone cross bedding is visible in the lower left near the pencil. *Conichnus conicus* is present, as is *Ophiomorpha* sp, the trace of a subtidal burrowing shrimp. (C) Cave wall at lower entrance to Chinese Fire Drill Cave, showing herringbone cross bedding. (D) Cave wall at the Pink Grotto, adjacent to Altar Cave, showing back-beach breccia blocks above subtidal sands with herringbone cross bedding, and below overlying back-beach calcarenites.

Examples of this dissolutional power and speed can be seen in the formation of syndeositional caves in the Bahamas. Altar Cave (Fig. 1) and Chinese Fire Drill Cave (Fig. 2) on San Salvador Island, and A-Survey Cave on New Providence Island (Fig. 3) are examples of syndeositional caves. All three caves are developed in subtidal, beach, back beach, and eolian carbonate facies of the Cockburn Town Member of the Grotto Beach Formation (Fig. 4). The Grotto Beach Formation was deposited during the transgression, stillstand, and regressive phases of MIS 5e (see Carew and Mylroie, 1995b; 1997 for a full discussion of Bahamian carbonate geology and stratigraphy). The Cockburn Town Member represents the stillstand and regressive phase of that highstand, and it contains facies, above modern sea level, identified as subtidal based on *in situ* fossil corals, herringbone cross bedding, and trace fossils such as *Ophiomorpha* sp. Only the MIS 5e sea-level highstand could

have produced the Cockburn Town Member subtidal facies above modern sea level; there are no known subtidal facies from any other glacioeustic sea-level highstand observed in the Bahamas. However, the flank margin caves found in these Cockburn Town Member rocks could only have been produced on the MIS 5e sea-level highstand. Both the rock, and the flank margin caves within them, had to develop on the same sea-level highstand.

In the examples given, the Cockburn Town Member rocks were part of a progradational process where carbonate sand supply into lagoons exceeded the accommodation space in the lagoon, and the lagoon began to fill in. As this infilling occurred, the beach, back beach, and eolian depositional environments migrated seaward over the subtidal facies (Fig. 5). The fresh-water lens also migrated seaward inside the back beach and eolian sands as they advanced into the

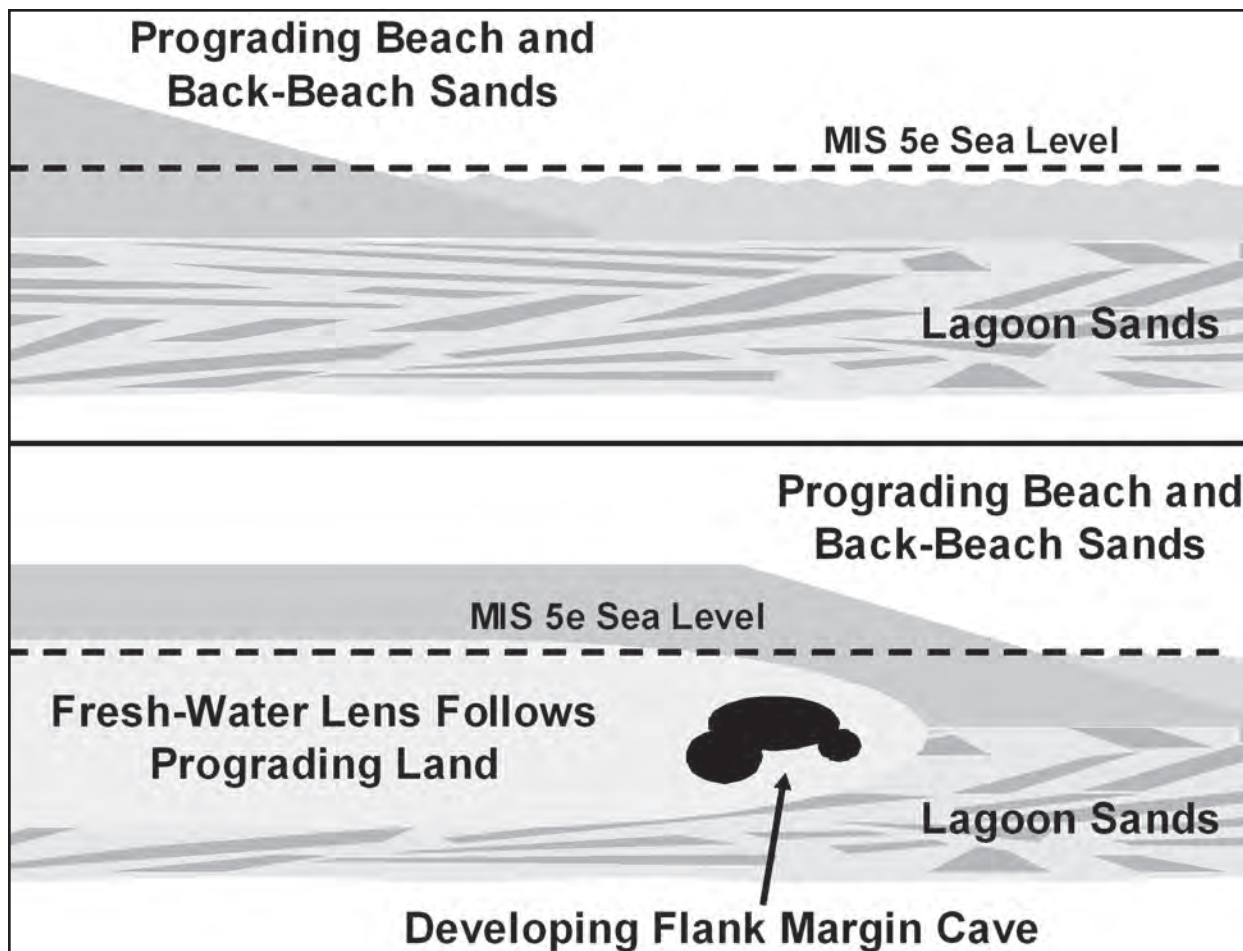

Figure 5: Diagrammatic representation of syndepositional cave development in prograding sands. (A) Shallow lagoon with excess sand supply, such that beach and back beach sands prograde seaward. (B) As sand progradation continues, the fresh-water lens also migrates seaward, allowing flank margin caves to develop in a sand body still undergoing deposition as eolian facies later cover the back beach sands.

lagoon. The flank margin cave dissolutional environment went to work immediately to create macroscopic voids within these sand units. The dissolution would have been able to begin before complete development of the back beach and eolian carbonate deposits above the voids. Therefore, as the caves began to form, the limestone above them was still being deposited. Such a setting qualifies as a syndepositional cave environment. The deposits cannot be the result of a true regression caused by sea-level fall, for then the fresh-water lens would not be at the necessary elevation to produce the phreatic voids as observed today. Even in this extremely youthful setting, the ability of these voids to persist and avoid collapse indicates that cohesion and early cementation are acting strongly enough while deposition continues to prevent loss of mechanical stability in these young caves.

Conclusions

Caves in carbonate rocks can be classified based on the

diagenetic stage of the rocks they occupy. Syngenetic caves form in rocks that maintain most of their primary porosity, and commonly develop in the coastal settings where the carbonates were deposited, making the rocks subject to the flank margin dissolution and related models of cave development tied to fresh-water lenses. The results are caves with a unique passage pattern. Caves in mesogenetic rocks are subject to temperatures, pressures, and perhaps confined conditions that also give them a unique structure and configuration. Caves formed in telogenetic settings, the ones best known to most karst scientists, have a third set of patterns. Mesogenetic caves may have inherited some aspects of their void structure from an initial eogenetic condition; likewise, telogenetic caves may have inherited some of their structure from earlier mesogenetic (or eogenetic) conditions. Marble caves represent a clean slate, in that metamorphism most likely removes almost all evidence of any pre-existing karst fabric.

Syn depositional caves are a unique and special case of syngenetic cave formation. Their existence is a boundary condition at one end of the time line of cave development. Their existence also is an indicator of how rapidly caves can form by dissolution. Because these carbonate sands commonly have depositional porosity of 30% or more, the amount of rock necessary to dissolve to make a cave void is proportionally less. Because flank margin caves form as mixing chambers without entrances, the entire void must be dissolutionally excavated; there is no option for mechanical transport of loose grains out of the system, as in epigenic caves. These factors all indicate that dissolution in the lens margin is powerful and fast. Such dissolutional power and speed are necessary to create caves fast enough that they can form syndepositionally.

References

- Bögli, A., 1980, Karst Hydrology and Physical Speleology. Springer Verlag, New York, 284 p.
- Carew, J.L., and Mylroie, J.E., 1995a, Quaternary tectonic Stability of the Bahamian Archipelago: Evidence from fossil coral reefs and flank margin caves: *Quaternary Science Reviews*, **14**, p. 144–153.
- Carew, J.L., and Mylroie, J.E., 1995b, A stratigraphic and depositional model for the Bahama Islands, *in* Curran, H. A. and White, B., (Eds.), *Geological Society of America Special Paper 300, Terrestrial and Shallow Marine Geology of the Bahamas and Bermuda*, p. 5–31.
- Carew, J.L. and Mylroie, J.E., 1997, Geology of the Bahamas, *in* Vacher, H. L., and Quinn, T. M., (Eds.), *Geology and hydrogeology of carbonate islands*, Elsevier Science Publishers (948 p.), p. 91–139.
- Chen, J.H., Curran, H.A., White, B. and Wasserburg, G.J., 1991, Precise chronology of the last interglacial period: ^{234}U - ^{230}Th data from fossil coral reefs in the Bahamas: *Geological Society of America Bulletin*, **103** p. 82–97.
- Chouquette, P.W., and Pray, L.C., 1970: Geologic nomenclature and classification of porosity in sedimentary carbonates.- *American Association of Petroleum Geologists Bulletin*, **54**, 207–250.
- Florea, L.J., Mylroie, J.E., and Price, A., 2004, Sedimentation and porosity enhancement in a breached flank margin cave: *Carbonates and Evaporites*, v. 19, p. 82–92.
- Jennings, J.N., 1968, Syngenetic karst in Australia. In: Williams, P.W. & Jennings, J.N. (Eds.): *Contributions to the Study of Karst*, Department of Geography Publication no. G/5, Australian National University, 41–110.
- Mylroie, J.E. and Mylroie, J.R., 1990, Meander Cutoff Caves and Self Piracy: The consequences of meander incision into soluble rocks: *National Speleological Society Bulletin*, **52**, p. 33–44.
- Mylroie, J.E. and Mylroie J.R., 2007, Development of the Carbonate Island Karst Model: *Journal of Cave and Karst Studies*, **69**, p. 59–75.
- Mylroie, J.E., Mylroie, J.R., Owen, A.M., and Waterstrat, M.J., 2008, Cave and karst inventory of the Primeval Forest, New Providence Island, Bahamas: Unexpected discoveries. *In* Freile, D., and Park, L., eds., *Proceedings of the 13th Symposium on the geology of the Bahamas and Other carbonate regions*, p. 107–118.
- Palmer, A.N., 1991: Origin and morphology of limestone caves: *Geological Society of America Bulletin*, **103**, 1–21.
- White, S.Q., Grimes, K., and Mylroie, J.E., 2007, (abstract) The earliest time of karst cave formation: *Acta Carsologica*, v. **36:1**, p. 240.

NEW MINERALS IN CAVES FROM SAN SALVADOR ISLAND, BAHAMAS

BOGDAN P. ONAC^{1,2}, JONATHAN SUMRALL¹, JOHN E. MYLROIE³, JOE B. KEARNS⁴

¹University of South Florida, Department of Geology, 4202 E. Fowler Ave., SCA 528, Tampa, FL 33620, USA

²"Babeş-Bolyai" University Cluj/"Emil Racoviţă" Institute of Speleology, Clinicilor 5, 400006 Cluj, Romania

³Mississippi State University, Department of Geosciences, Mississippi State, MS 39762, USA

⁴The Pennsylvania State University, Materials Research Institute, University Park, PA 16802, USA

Abstract

The Bahamas represent carbonate banks that have been in existence since the Mesozoic Era as tectonically-stable and isostatically-subsiding platforms. The island of San Salvador, located on the eastern edge of the Bahamian platform, is home to a number of caves. The stratigraphy of the San Salvador consists of the Holocene Rice Bay Formation, a terra rosa paleosol, the transgressive-phase eolianite/subtidal/regressive-phase eolianite carbonate package of the Grotto Beach Formation, a terra rosa paleosol, and eolianites and terra rosa paleosols from several sea-level fluctuations designated as the Owl's Hole Formation. Today, the surficial geology is entirely Quaternary limestone, modified by karst processes. The limestones on the island are carbonate eolianites, which are relatively pure. Caves for this study fall into two categories: *pit caves* and *flank margin caves*. Pit caves form as a result of percolating meteoric water, which collects in epikarst, dissolving limestone. Flank margin caves form on the distal margins of the fresh-water lens at the location where fresh water and seawater mix.

Based on the limestone's simple mineralogy, one would expect only calcite and aragonite speleothems to form. A preliminary study, however, looked at deposits in 17 caves and found 20 minerals, out of which, 6 (bold faced in the list below) are for the first time described from San Salvador. The surprisingly diverse mineralogy of these deposits is due to the presence of bat colonies, sea spray aerosols, tidal fluctuations of seawater/brackish water in some caves, and microbiological processes acting at various boundaries (air/cave wall and air/water). Mineral samples from the caves include: speleothems, wall crusts, nodules, earthy material on the floor of caves, and corroded products recovered from walls or different cave formations. The minerals identified so far are: Calcite [CaCO₃], Aragonite [CaCO₃], Gypsum [CaSO₄·2H₂O], Celestine [SrSO₄], Cesanite [Na₃Ca₂(SO₄)₃(OH)], Apatite-(CaCl) [Ca₅(PO₄)₃Cl], Apatite-(CaF) [Ca₅(PO₄)₃F], Apatite-(CaOH) [Ca₅(PO₄)₃(OH)], Archerite [KH₂PO₄], Ardealite [Ca₂(HPO₄)(SO₄)·4H₂O], Biphosphammite [(NH₄K)H₂PO₄], Brushite [CaHPO₄·2H₂O], Collinsite [Ca₂(Mg,Fe)(PO₄)₂·2H₂O], Hopeite [Zn₃(PO₄)₂·4H₂O], Monetite [CaHPO₄], Whitlockite [Ca₉(Mg,Fe²⁺)(PO₄)₆(PO₃,OH)], Darapskite [Na₃(SO₄)(NO₃)·H₂O], Niter [KNO₃], Nitratine [NaNO₃], and Halite [NaCl].

**CAVE SEDIMENTS RELATED TO CRETACEOUS – TERTIARY PALEOKARST
DEVELOPED IN EOGENETIC CARBONATE ROCKS: EXAMPLES FROM SW
SLOVENIA AND NW CROATIA**

BOJAN OTONIČAR

Karst Research Institute SRC SASA, Titov trg 2, 6230 Postojna, Slovenia

Abstract

In the southwest Slovenia and northwest Croatia a regional paleokarstic surface separates the passive margin shallow-marine carbonate successions of different Cretaceous formations from the Upper Cretaceous to Eocene palustrine and shallow marine limestones of the synorogenic carbonate platform. Thus, the paleokarst corresponds to an uplifted peripheral foreland bulge, when diagenetically immature
eo

EOGENETIC KARST OF THE CARBONATE ISLANDS OF THE NORTHERN MARIANAS

KEVIN W. STAFFORD¹, JOHN W. JENSON², JOHN E. MYLROIE³

¹Geology Department, Stephen F. Austin State University, Nacogdoches, TX 75962, USA

²Water and Environmental Research Institute of the Western Pacific, University of Guam, Mangilao, 96923, Guam

³Department of Geosciences, Mississippi State University, Mississippi State, MS 39762, USA

The Northern Mariana Islands are tectonically active components of the Mariana Arc complex. Individual islands are predominantly composed of Paleogene volcanic rocks mantled by Neogene and younger eogenetic carbonates that have never been buried beyond the range of meteoric diagenesis. As predicted by the Carbonate Island Karst Model (CIKM), cave development is largely controlled by the position of the freshwater lens, where: (1) the decay of organics increases fluid acidity at the upper and lower boundaries of the freshwater lens; (2) the mixing of fresh and saline waters at the bottom of the lens, and vadose water with the top of the lens, increases CaCO₃ dissolution; and (3) the volume of water passing through the margin of the lens enhances dissolution rates. Karst development characteristic of the CIKM is widespread throughout the Northern Mariana Islands, including flank margin caves and banana holes, which form horizontal levels marking previous sea-level stillstands. Multiple horizons of flank margin caves have been found throughout the Marianas, attesting to differential rates of island uplift coupled with glacioeustatic sea-level fluctuations.

In addition to flank margin caves, structurally- and lithologically-controlled caves are abundant throughout the Northern Mariana Islands. Contact caves are readily found at the contact between non-carbonate basement rocks and overlying carbonate rocks where allogenic recharge is focused into the subsurface. Fissure caves associated with bank margin failures and island arc tectonism are widespread throughout the region. Fissure caves, both active and inactive, commonly show horizontal widening as a result of lateral discharge of freshwater along a fracture that mixed with saltwater at a coastal discharge elevation. Fissure caves and lithologic variability add much complexity to the groundwater flow throughout the Northern Mariana Islands, often causing the hydrologic subdivision of groundwater resources within individual islands, such that partitioned regions of individual islands often behave hydrologically independent of other regions of the same island. Unraveling the complexities of karst development within the Northern Mariana Islands has significantly aided in the advancement of the Carbonate Island Karst Model.

1. Introduction

The Mariana Islands, located in the western Pacific Ocean (Fig. 1), are active components of the Mariana Arc complex associated with subduction of the Pacific Plate along the Mariana Trench. The Marianas consist of 17 islands, including Guam, Rota, Aguijan, Tinian, Saipan, and Farallon de Medinilla (Fig. 1). The remaining islands have minimal, if any, carbonate strata. Guam is a protectorate of the United States, while the remaining islands are governed by the Commonwealth of the Northern Mariana Islands.

The islands of Rota, Aguijan, Tinian, Saipan, and Farallon de Medinilla are largely composed of Paleogene volcanic tuffs and breccias mantled by Neogene and more recent carbonate strata (Cloud et al., 1956; Doan et al., 1960; Tracey et al., 1964). Carbonate rocks are diagenetically

immature and have not been buried beyond the range of meteoric diagenesis. Annual precipitation averages 2000 mm with a distinct wet and dry season (Gingerich and Yeatts, 2000). Temperature ranges from 20° to 30° Celsius. Dense woody vegetation occupies carbonate regions, while grass dominates non-carbonate regions (Doan et al., 1960).

Geomorphology in the Northern Mariana Islands is largely controlled by three factors: (1) original volcanic deposition, (2) original carbonate deposition, and (3) structural deformation, primarily brittle failure (Stafford et al., 2005). Karst development is prolific throughout the carbonate facies (Fig. 2), including multiple horizons, associated with previous sea level still stands. Karst porosity also occurs associated with fissuring and lithologic variability.

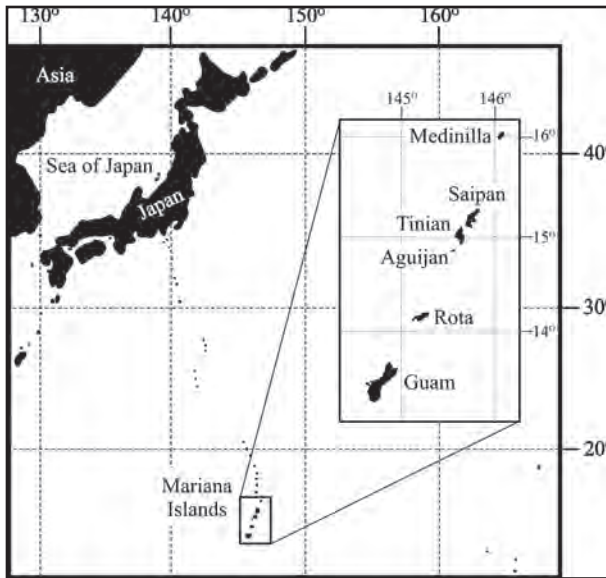

Figure 1: Map showing location of the Mariana Islands, with the six southernmost islands containing significant carbonate rocks shown expanded (adapted from Stafford et al., 2005).

2. Fresh Water Lens Karst Development

Cave development associated with the vertical migration of the past freshwater lenses is preserved on Rota, Aguijan, Tinian and Saipan, in the form of well-developed horizons of flank margin caves (Fig. 3). At least four independent horizons of flank margin caves are documented on Tinian alone (Stafford et al., 2005), with similar amounts for the

Rota, Aguijan and Saipan. The caves form horizontal trends of features largely isolated from one another (Fig. 3), which at times coalesce to form complex interconnected structures (Fig. 4) (Jenson et al., 2006). Individual flank margin caves exhibit globular morphologies where individual chambers appear to randomly intersect one another as a result of solutional chamber enlargement, forming integrated networks of chambers. Multiple levels of caves attest to differential rates of island uplift coupled with glacioeustatic sea-level change.

Traditionally, flank margin cave development has been associated with combination of mixing of vadose / phreatic mixing at the top of the lens, fresh and saline water mixing at the bottom and margin of the lens and the decay of organics at the top and bottom of the lens (Myroie and Carew, 1995). At the margin of the lens, the top and bottom of the lens come into close contact, thus placing the organic decay and fluid mixing in close proximity, such that the processes are contributing simultaneously. However, recent studies are beginning to show that the most important factor in controlling flank margin cave development is simply the volume of water that is being discharged through the margin of the freshwater lens (Moore et al., 2007), and that mixing and organic decay only play a secondary role.

In addition to flank margin caves, few “banana holes” have been found in the Northern Mariana Islands (Jenson et al., 2006), although they are extremely common on some Bahamian Islands (Myroie et al., 1995). It is likely that karst

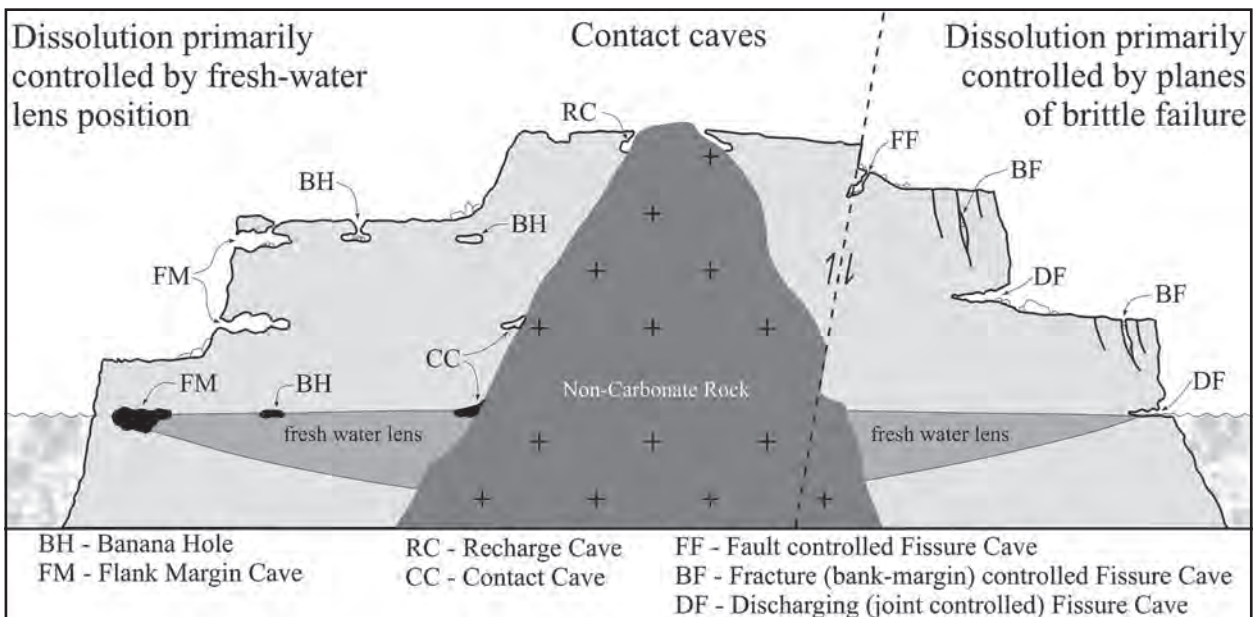

Figure 2: Schematic diagram depicting the different types of caves that are commonly encountered in the Northern Mariana Islands (adapted from Stafford et al., 2005).



Figure 3: Horizons of flank margin cave development on Tinian (A, telephone pole in left foreground for scale), Rota (B, cave opening in center left is 2 m high) and Aguijan (C, people in foreground for scale) showing the position of paleo-freshwater lenses.

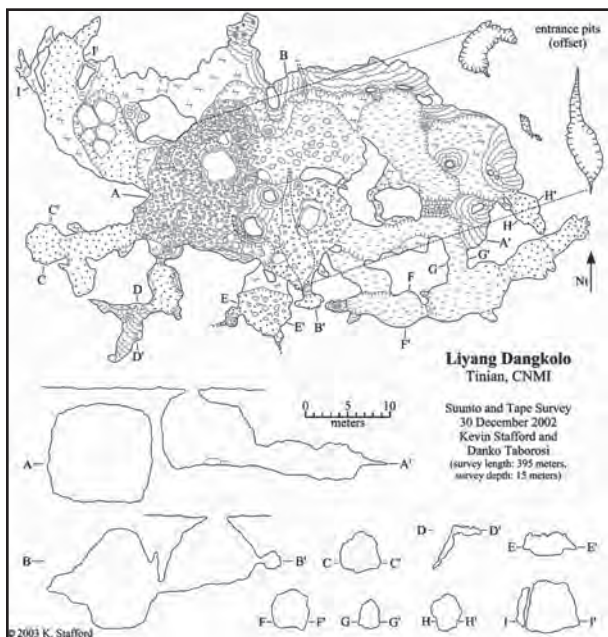

Figure 4: Map of Liyang Dangkolo, a complex flank margin cave on Tinian showing the coalescing of multiple globular chambers (from Stafford, 2003).

development associated with isolated dissolution at the top of the freshwater lens is more common in the Northern Mariana Islands than observed, but these features are simply not exposed at the surface for study because of thick sequences of overlying carbonate strata that separate paleo-freshwater lens horizons, preventing banana hole expression by collapse (Fig. 2).

3 Lithologically Controlled Karst Development

On Rota, Tinian and Saipan, Neogene volcanics are exposed at the land surface, largely in the highest elevation island interiors (Cloud et al., 1956; Doan et al., 1960). These volcanics readily weather into thick residual clay deposits that effectively serve as impermeable surfaces inhibiting the infiltration of groundwater. Much of the precipitation landing on these surfaces is transported as overland flow to the periphery of the non-carbonate terrains to where it descends into the subsurface at contacts with overlying carbonate strata (Stafford et al., 2005). This allogenic recharge results in enhanced dissolution at the contact between carbonate and non-carbonate rocks, producing

what has been termed contact caves (Fig. 5) (Jenson et al., 2006). Often these features consist of large closed depressions with little or no cave that is humanly enterable because clay sediments derived from volcanic weathering have infilled the dissolutional features.

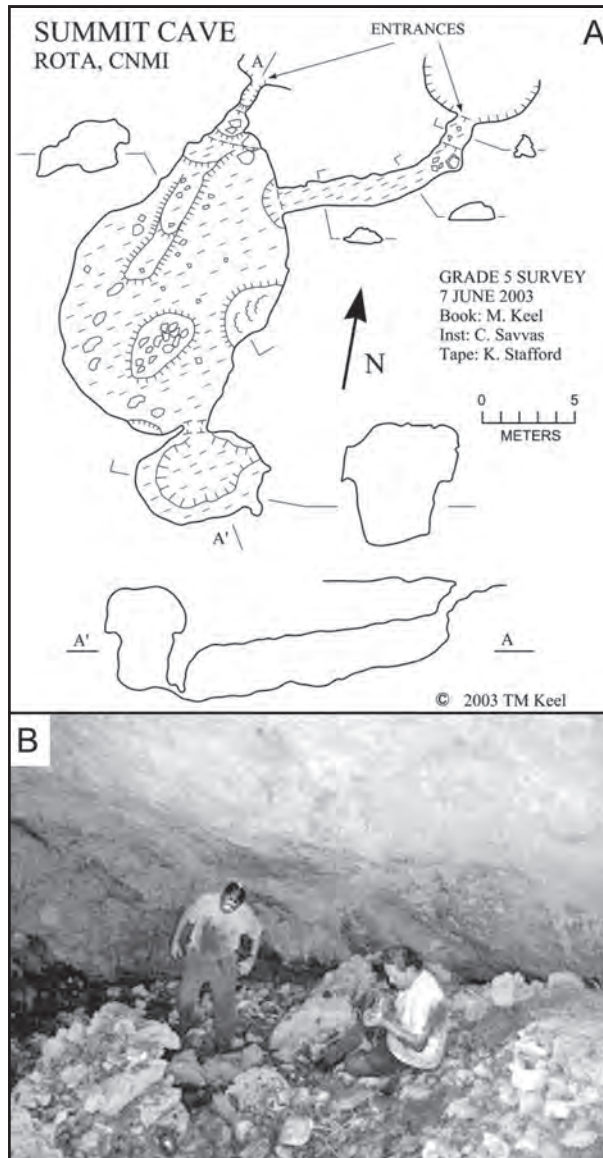

Figure 5: Contact cave on Rota showing solutional development at the contact between the volcanic core of the island and carbonate rocks that mantle it. Note the restricted entrances that have been largely filled with allogenic sediment derived from the noncarbonated terrains (A) and the abundant breakdown clasts (B) resulting loss of support as dissolution is focused at the carbonate / noncarbonated contact (map from Keel, 2005).

On Saipan, additional lithologic controls have been documented where interbedded ash layers in carbonate rocks act as aquitards (Jenson et al., 2006). Here, volcanic

ash layers have effectively partitioned portions of the freshwater lens resulting in compartmentalization of groundwater flow throughout the island. Caves including vertical lift features (Jenson et al., 2006), have developed where confined fluids have risen along lithologic boundaries to form hypogene karst features within diagenetically-immature rocks.

4. Fissure Karst Development

Fissure karst is prevalent throughout the Northern Mariana Islands, where long, linear caves with a significant vertical component have developed along linear trends (Stafford et al., 2005). These fissure caves appear to form along faults, fractures and joints. Throughout the Northern Mariana Islands, three distinct types of fissure caves have been identified, each related to a specific type of brittle deformation (Fig. 2): (1) faults; (2) margin failures; and (3) tension-release fractures (Jenson et al., 2006). Fissure caves in general act as fast flow routes for vadose water, and for phreatic fluids, where they provide high-permeability flow paths for freshwater migration towards the margin of the lens.

Fissure caves associated with faults descend at moderate slopes and often show horizontal widening (Fig. 6E) (Stafford et al., 2005). Widening often occurs because of solution of lower levels and then upward collapse of the hanging wall. While no caves have been visited in the Northern Marianas with observable fault offsets, many of these features do correspond with documented faults identified from surface mapping (Stafford et al., 2005). It is likely that are simply not observable in these caves because of extensive breakdown combined with abundant secondary deposits coating wall and ceiling surfaces.

Fissure caves that develop parallel or near-parallel to scarps and coastlines have formed along bank margin failures, where undercutting and slope failure has produced linear fractures with minimal offset (Stafford et al., 2005). Fissure caves associated with bank margin failures tend to be near vertical with limited widths but horizontally extensive (Fig. 6A,D), forming the deepest caves on most of the Northern Mariana Islands (Stafford et al., 2005). Many of these caves have significant components that are currently unroofed due to ceiling collapse, but appear to have been covered for significant periods of time in the past based on secondary calcite deposits commonly observed in unroofed sections.

Fissure caves associated with tension-release fractures occur perpendicular or sub-perpendicular to scarps and coastlines, where fractures have developed due to block rotation

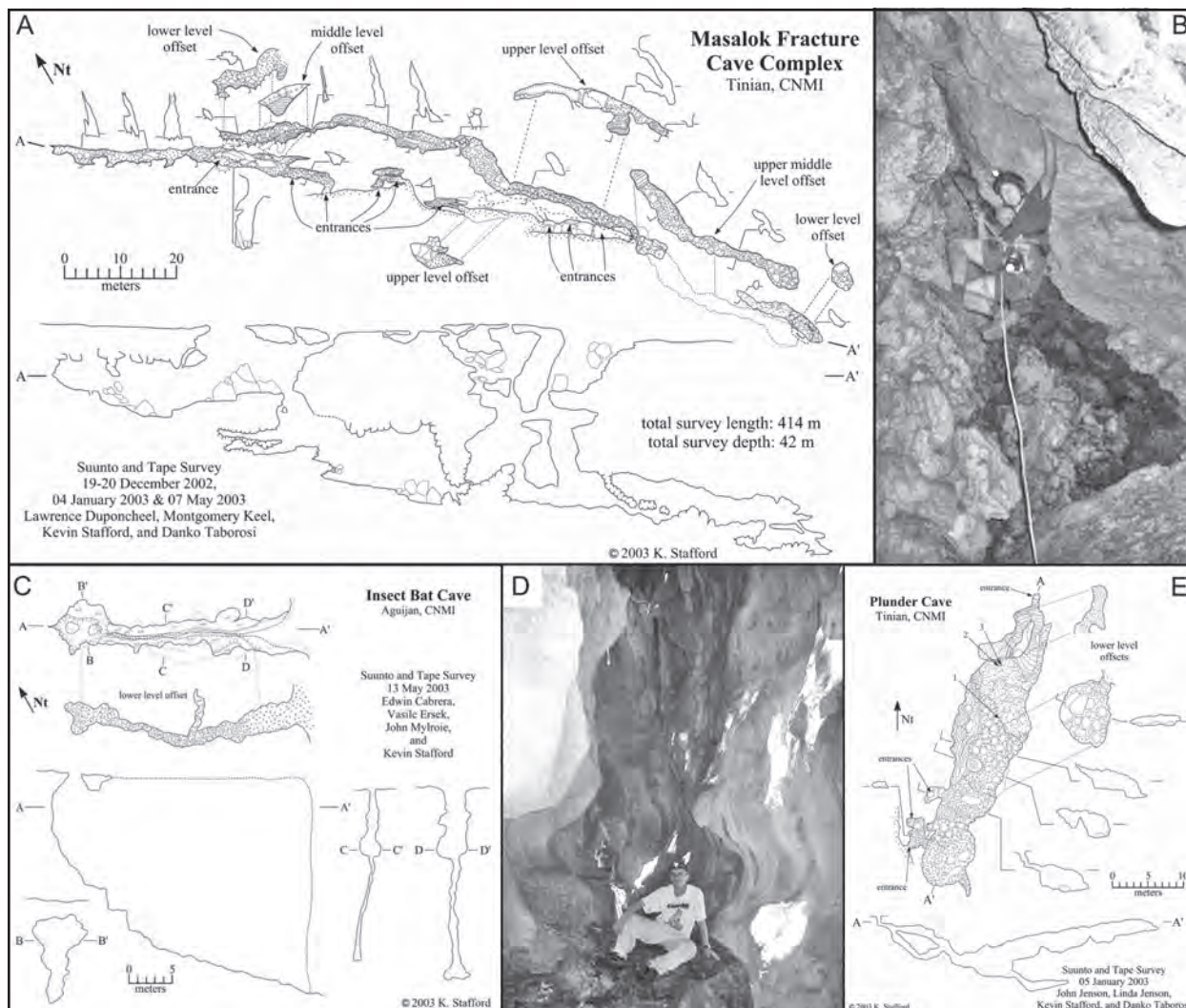

Figure 6: Fissure caves associated with bank margin failures tend to be laterally extensive (A), nearly vertical (B) and can reach significant depths (A). Fissure caves associated with tension-release fractures extend inland perpendicular to scarps (C) and often show horizontal widening (D) associated with increased dissolution from the mixing of spring discharge on seawater. Fissure caves developed along faults (E) often show horizontal widening when intersecting the water table (maps from Stafford, 2003).

associated with bank margin failures (Stafford et al., 2005). These features commonly extend inland for more than 30 meters with distinct joints or fractures located along the central axis of the ceilings and floors (Fig. 6C) (Stafford et al., 2005). When found at sea level, they commonly discharge freshwater from their inland portions. Most exhibit horizontal widening (Fig. 6D), most likely as a result of the mixing of discharging freshwater with seawater, when they formed at sea level. Therefore, this type of fissure cave can be used to identify previous freshwater lens positions just like flank margin caves, while also indicating zones of discrete discharge along paleo and modern coastlines.

5. Conclusions

Cave and karst development on Rota, Aguijan, Tinian, and Saipan is extensive. Multiple horizons of flank margin caves record changes in freshwater lens position as a result of differential uplift and glacioeustatic sea level variability, including at least four major paleo-freshwater lens horizons. Contact caves focus allogenic recharge from noncarbonated terrains into the subsurface. Fissure caves form laterally extensive features that act as hydrologic fast flow routes, where high permeability pathways significantly alter groundwater flow, often partitioning portions of the islands into hydrologically isolated sections. The recognition of fissure caves and their importance in island karst development within the Northern Mariana Islands adds to the complexity of Carbonate Island Karst Model.

References

- Cloud, P.E., Jr., Schmidt, R.G., and Burke, H.W. (1956) Geology of Saipan, Mariana Islands, Part 1, General Geology, 280-A. U.S. Geological Survey Professional Paper, U.S. Government Printing Office, Washington, D.C., 129 p.
- Doan, D.B., Burke, H.W., May, H.G., Stensland, C.H. and Blemenstock, D.I. (1960) Military Geology of Tinian, Mariana Islands. Chief of Engineers, U.S. Army, 149 p.
- Gingerich, S.B. and Yeatts, D.S. (2000) Ground-Water Resources of Tinian, Commonwealth of the Northern Mariana Islands, Water Resources Investigations Report 00-4068. U.S. Department of the Interior, Washington, D.C., 2 sheets.
- Jenson, J., Keel, T.M., Mylroie, J.E., Mylroie, J.R., Stafford, K.W., Taborosi, D. and Wexel, C. (2006) Karst of the Mariana Islands: the interactions of tectonic, glacio-eustasy, and freshwater/seawater mixing in island carbonates, in Harmon, R.S. and Wicks, C. (Eds), Perspectives on Karst Geomorphology, Hydrology, and Geochemistry – a tribute to Derek C. Ford and William B. White. Geological Society of America Special Paper 404, Boulder, CO, 129–138.
- Keel, T.M. (2005) The Caves and Karst of Rota Island, Commonwealth of the Northern Mariana Islands [MS Thesis], Mississippi State University, Mississippi State, MS, 206 p.
- Moore, P.J., Martin, J.B. and Mylroie, J. (2007) Rapid development of secondary porosity within freshwater lenses of carbonate islands. Geological Society of America Abstracts with programs, **39:6**, 467.
- Mylroie, J.E. and Carew, J.L. (1995) Karst development on carbonate islands, in Budd, D.A., Harris, P.M. and Staller, A. (Eds), Unconformities and Porosity in Carbonate Strata. AAPG Memoir 63, Tulsa, OK, 55–76.
- Mylroie, J.E., Carew, J.L. and Vacher, H.L. (1995) Karst development in the Bahamas and Bermuda, in Curran, H.A. and White, B (Eds), Terrestrial and Shallow Marine Geology of the Bahamas and Bermuda, 251–267.
- Stafford, K.W. (2003) Structural Controls on Megaporosity in Eogenetic Carbonate Rocks: Tinian, CNMI [MS Thesis], Mississippi State University, Mississippi State, MS, 340 p.
- Stafford, K.W., Mylroie, J., Taborosi, D., Jenson, J. and Mylroie, J. (2005) Karst development on Tinian, CNMI: controls on dissolution in relation to the Carbonate Island Karst Model. Journal of Cave and Karst Studies, **67:1**, 14–27.
- Tracey, J.I. Jr., Schlanger, S.O., Stark, J.T., Doan, D.B. and May, H.G. (1964) General Geology of Guam, 403-A. U.S. Geological Survey Professional Paper, U.S. Government Printing Office, Washington, D.C., 104 p.

COASTAL DISCHARGE FEATURES FROM AN UPLIFTED CARBONATE ISLAND AQUIFER: NORTHERN GUAM, MARIANA ISLANDS

DANKO TABOROŠI¹, JOHN W. JENSON², JOHN M.U. JOCSON², JOHN E. MYLROIE³

¹Island Research & Education Initiative, PO Box PS 303, Palikir,

Pohnpei, FM 96942, Federated States of Micronesia,

²Water and Environmental Research Institute of the Western Pacific, University of Guam,
Mangilao, GU 96923, Guam

³Department of Geosciences, Mississippi State University, Mississippi State, MS 39762, USA

Field studies of the coasts of Guam and similar islands composed of uplifted, geologically-young limestones show that groundwater discharge on such coasts is heterogeneously distributed among four characteristic types of discharge features: (1) Beach seeps and springs, (2) Reef springs and seeps, (3) Fracture springs, and (4) Cave springs. Each of these features is associated with specific coastal environments and morphologies, and each accounts for a substantial portion of the total flow and discharge. This discharge is in contrast, for example, to non-carbonate aquifers, from which coastal discharge is dominated by diffuse flow, and continental karst aquifers in Paleozoic limestones, in which flow and discharge is dominated by conduit flow. Moreover, each type of feature appears to exhibit a characteristic hydrogeological association with the three components of karst aquifer porosity. Springs and seeps on beaches or reefs are associated primarily with diffuse, matrix porosity, while concentrated discharges from rocky coasts emerge from dissolution-widened fractures, and from flowing conduits. Although the conditions of the coastal zone make it difficult to accurately quantify the absolute or relative discharges from each type of feature, the substantial flows exhibited by each indicates that the aquifers of islands composed of uplifted, geologically-young limestones can generally be expected to be triple-porosity aquifers, in which each type of porosity makes a substantial contribution to discharge and probably to internal flow as well.

1. Introduction

This paper describes the coastal discharge features of northern Guam (Fig. 1), based on a decade of field study by the authors and their colleagues. Initial observations of the limestone coast were made by Jenson et al. (1997) and Jocson et al. (1999) to gain a better understanding of the discharge boundary conditions for models of the limestone aquifer (Contractor and Jenson, 2000; Jocson et al., 2002). Taboroši (2000) subsequently undertook an intensive two-year field study aimed at inventorying and describing the karst of Guam in terms of a general model of carbonate island karst (Mylroie et al., 2001; Jenson et al., 2006), which included subaerial observations of the coastal zone on foot and by boat, and underwater observations of fringing reefs by free diving and on SCUBA. General observations from this work are reported by Taboroši (Taboroši, 2006) and Taboroši et al. (2005). Related studies involving the coastal zone of Guam include a dye trace by Moran and Jenson (2004) to better characterize groundwater flow, a study of coastal water fluorescence by Hoffman et al. (2007), and a comprehensive aerial survey of the coastline by Taboroši (2008). This paper describes the unique set of features by which groundwater discharges from the

uplifted geologically-young, i.e., eogenetic (see Vacher and Mylroie, 2002), limestone aquifer of northern Guam. Groundwater on such coasts does not discharge in spatially and volumetrically uniform coastal seepage, but rather from a geographically uneven and morphologically heterogeneous

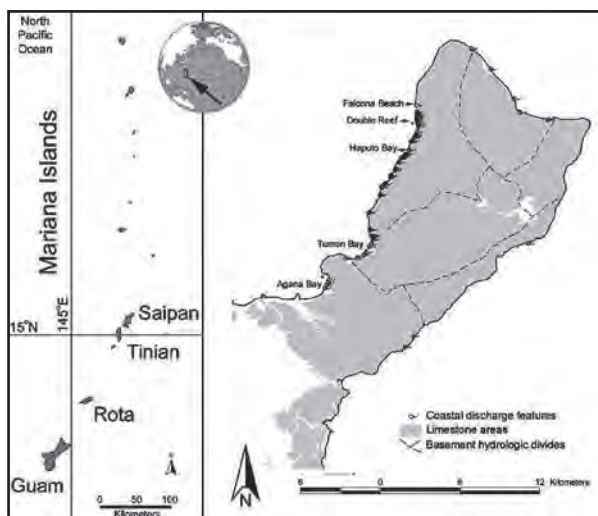

Figure 1: Map of northern Guam showing the locations mentioned in text.

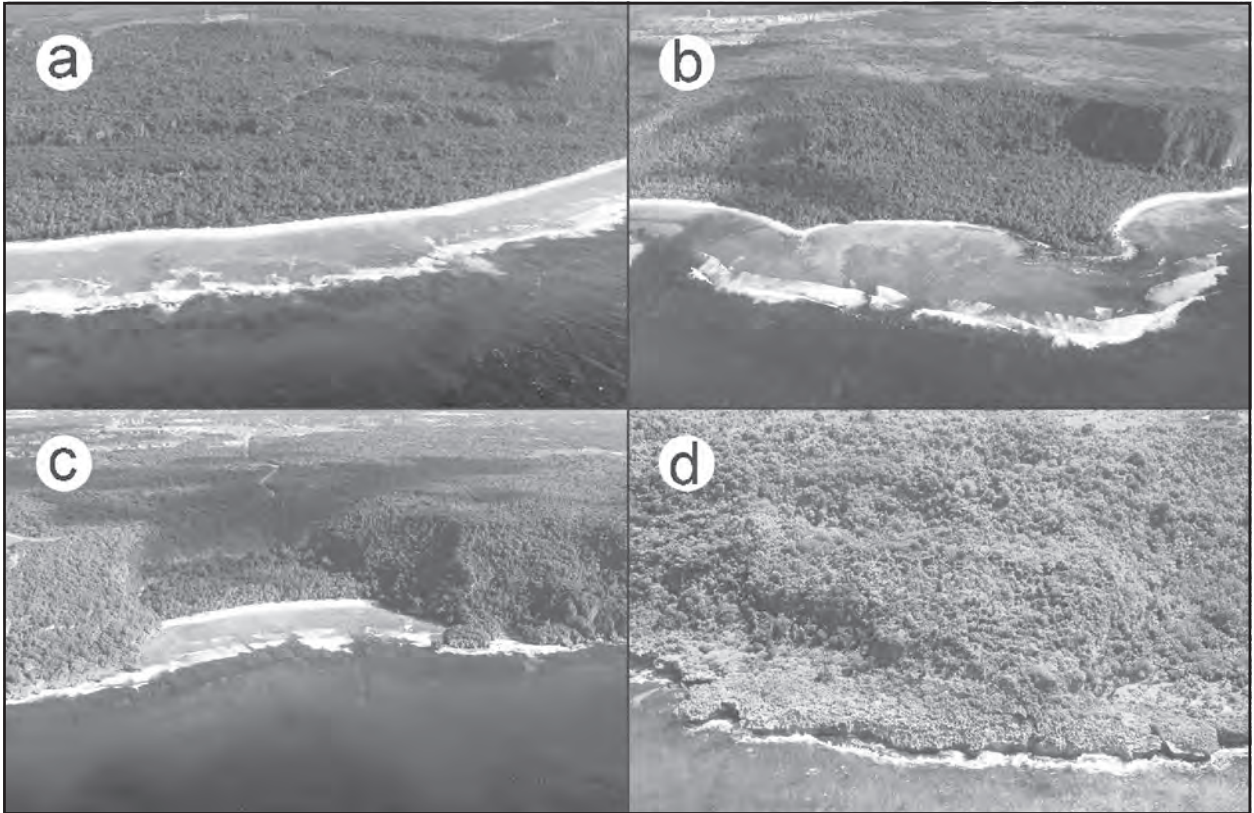

Figure 2: Aerial views of different types of coastline in northern Guam. (a) linear sandy beach, (b) broad embayments, (c) well-developed embayment, (d) rocky shore.

system of springs and seeps. The coastline of Guam exhibits three distinct morphologies: long linear sandy beaches (12%), sickle-shaped sandy beaches within embayments (20%), and rocky shorelines (68%) (Fig. 2.); which greatly differ in form, size, and discharge volumes. Their striking discharge diversity derives from the intricate nature of the karst pathways that feed them, their close relationships with coastal landforms, and the complex geologic history of the aquifer's vertical migrations in tune with relative sea level changes. Specifically, the coastal discharge features exhibited on Guam and similar islands are (Fig. 3): (1) Beach seeps and springs, (2) Reef springs and seeps, (3) Fracture springs, and (4) Cave springs. We briefly discuss each in the sections that follow.

2. Beach Springs and Seeps

Beach springs and seeps occur in the intertidal zone of sandy beaches (Fig. 2a). Springs emerge from distinct points and discharge focused flows (Fig. 3a and c). Seeps display no distinct discharge points, but only diffuse outflow (Fig. 3b). Both are widespread and easily observed on nearly any northern Guam beach. They are best seen at low tide, when they form meandering channels, parallel rills, and meter-scale mini-deltas in the beach sand (Fig. 3b). At high tide,

many become submerged and are difficult to identify. The larger springs, however, remain visible even at high tides as shallow water boils (Fig. 3c).

Prolific springs and seeps are most common within sandy embayments bounded by rocky coasts (Fig. 2 b-d). They are more or less continuous in the prominent embayments such as Tumon and Agana bays (Fig. 1), with rarely more than 100 meters separating adjacent major springs or seepage zones (Jenson et al., 1997). The embayment with most prolific freshwater discharge is Tumon Bay, where Jocson (1998) identified 12 major point-discharge features and numerous seepage zones spread over 3.4 km length of the beach, with an calculated flux of about 1000 l/s for the beach and reef combined (Jocson et al., 2002). Comparable springs and seeps are found on linear beaches as well, but appear to be fewer and less voluminous compared to those found on beaches within embayments. For comparison, the embayments of Agana, Tumon, Haputo, and Tanguisson (Fig. 1), with their total beach length of 10.5 km, exhibit more than 25 major point discharge features. The linear beaches of Falcona, Uruno, Ritidian, and Jinapsan, with their similar length of 9.1 km, contain only 4 major point discharge features.

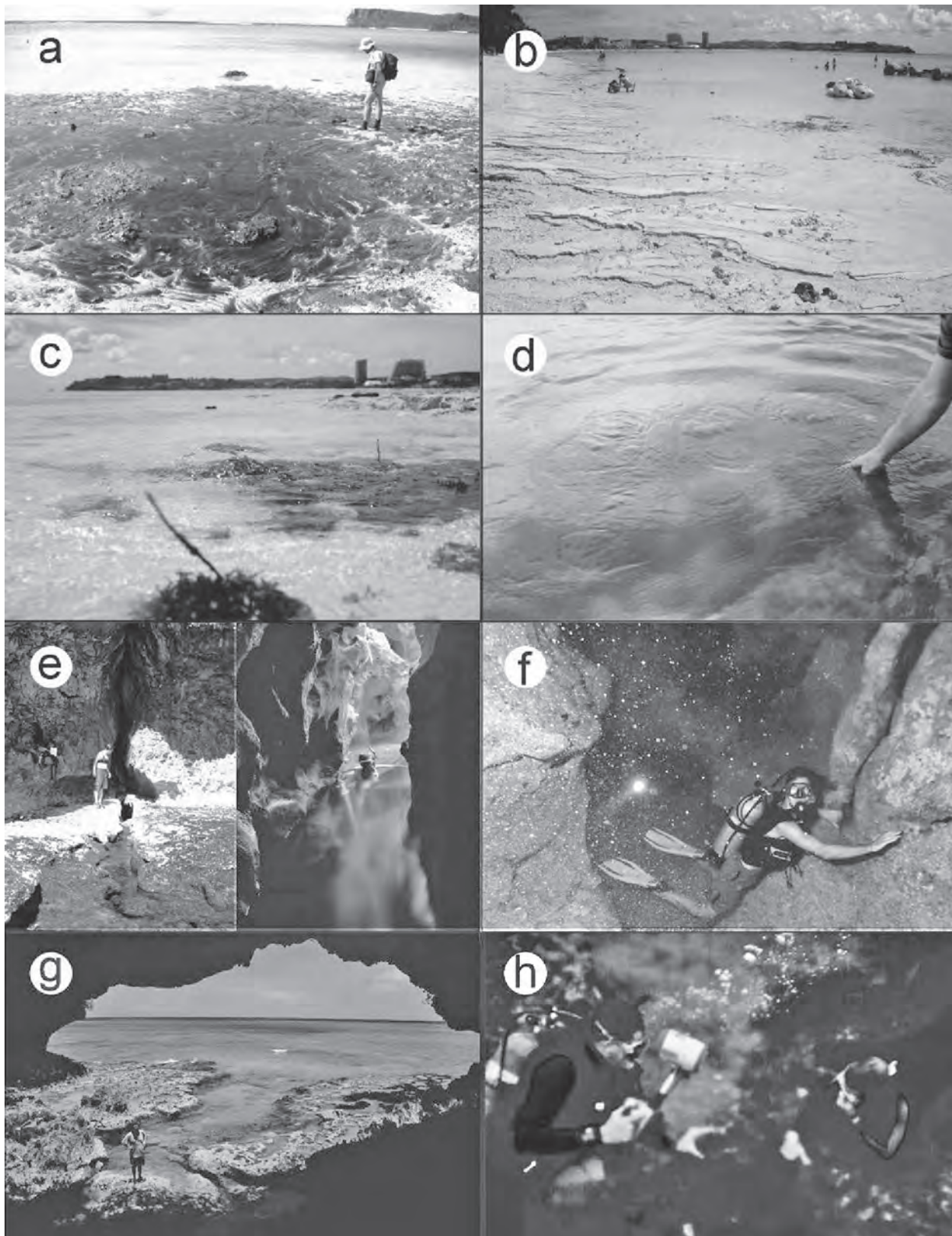

Figure 3: Different types of coastal discharge features in northern Guam. (a) beach seep zone where no distinct point of discharge can be observed, (b) beach springs at low tide, (c) beach spring at high tide, (d) reef spring, (e) fracture spring (outside and inside), (f) submarine fracture spring, (g) cave spring, (h) submarine cave spring.

3. Reef Springs and Seeps

Freshwater discharge also occurs in the subtidal zone of fringing reefs. Such springs and seeps occur on the flats of fringing coral and algal reefs, in depths ranging from a few centimeters to a few meters (Fig. 3d). Reef springs emerge from distinct points on the fringing reef platforms, whereas seeps are more difficult to trace to a specific point source. Their flux is very difficult to estimate underwater, but Jenson et al. (1997) reported that the single largest spring they found in Agana Bay emerges from the reef flat below the low tide mark. Estimating the flux is even more difficult for seeps, whose discharge cannot be traced to a specific discharge point, yet is obvious to snorkelers who readily identify it by plumes of cooler water and unmistakable “blurriness” due to refraction from density currents. Both reef springs and seeps appear to be a common feature of Guam’s fringing reefs, and are most frequently encountered in Tumon, Tanguisson, and Double Reef areas (Fig. 1).

4. Fracture Springs

Fracture springs form where fractures (joints and faults) carrying freshwater intersect the coast, and are the characteristic discharge type in the parts of coastline occupied by rocky outcrops and shear cliffs. The faces of sea cliffs in northern Guam expose countless fractures, which typically extend perpendicular to the coastline. Tracing the visible part of a fracture downward along the rock face often reveals a small spring at the waterline. This phenomenon can be observed on a variety of scales, ranging from tight joints only a few millimeters across to dissolution-widened vertical fractures up to several meters in width. The latter discharge free-surface streams of fresh water underlain by seawater, and are arguably the most interesting and unique type of discharge features on Guam. Similar features have been documented by Stafford et al. (2003) and Keel et al. (2005) in Tinian, Aguijan, and Rota, all similarly uplifted limestone islands in the Northern Mariana Islands (Fig. 1).

When seen from the coast, dissolutionally-widened fractures appear as vertical slits in sea cliffs. The slits are of uneven width and can reach several meters at the broadest points, mostly at or below the current sea level (Fig. 3e and f). The breadth generally decreases upward to close some 3-9 meters above the sea level, approximating a teardrop shape in section. If sufficiently wide, the fractures can be directly explored by entering through their openings in the cliff faces. They extend at approximately 90 degree angles to the coastline, and can be followed for some distance inland (up to 35 meters in one instance) but invariably taper off to a width that cannot be accessed. This tapering may indicate the landward limit of the mixing-dissolution front under

present sea-level conditions.

Because the fractures discharge steady flows they must be explored by swimming in cool free-surface streams of fresh or brackish water. Such streams are actually top layers of fresh water flowing on a base of underlying seawater, and typically appear “blurry” due to turbulence and water mixing. In the largest fractures, water flowing at the surface is drinkable, and depth to contact with underlying seawater can be up to one meter (see Gamble et al., 2003). Snorkelers can descend below the halocline into the warmer and clear sea water. When the sea is calm, sharp stratification of water in the fractures is readily observable when snorkeling, both from temperature contrast, as well as refraction of light at the halocline. Because sufficiently calm conditions are rare, accurate direct measurement of discharge therefore has yet to be undertaken. Field estimates by Jocson (1998), which were based on visual comparison with measured flows elsewhere rate the largest fractures to 50 liters per second, and Jenson et al. (1997) reported linear velocities of the surface flow along the center of the channel in some fractures to be up to 0.5 m/s. Fracture springs are fed by conduit flow through physical discontinuities in bedrock. These springs therefore represent termini of structurally-controlled preferential pathways for groundwater flow inside the aquifer. They are analogous to vadose canyon caves, but with seawater instead of rock providing the base for freshwater flow.

5. Cave Springs

Like fracture springs, cave springs are a characteristic type of discharge features in the rocky parts of northern Guam coast (Fig 3. g and h). They occur on various scales and in distinct morphologies, ranging in size and appearance from small interstices to large coastal caverns. Located at or near the sea level, they discharge fresh water from conduit-fed holes. The smallest springs of this type are cm-scale round holes in coastal rocks, from which fresh or brackish water discharges. The majority of examples recognized so far are active at or just below the sea level; no perched cases have been found. The association with the sea level is so close that holes known to discharge water at a high tide level become inactive during low tides, when outflow becomes diverted to a lower hole. On the other hand, permanently submerged springs of this type appear to be common. We refer to them as submarine vents. They usually occur at the bases of sea cliffs where the vertical rock wall connects to down-sloping bottom. An archetypal example was described by Jocson (1998) in the Double Reef area; it has three submarine vents in a group at the depth of 4 m just at the base of a sea cliff. Discharging an estimated 18 l/s combined, each of

the openings is less than a meter in diameter and does not appear to be associated with any fractures.

Larger features of this type of spring can be called cave springs in the narrow sense of the word because they can be entered by humans and traversed. Fieldwork so far has discovered a dozen or so examples, including a) large caves at the sea level, b) natural arches, collapsed caves, and alcoves at the sea level, and c) partly and fully submarine caves. The single largest traversable cave spring at the sea level is known as the Coconut Crab Cave, located about 300 meters south of Double Reef Beach. It is best seen at low tide and has been estimated to carry 225 l/s (Jocson, 1998).

Finally, there are some impressive submarine cave springs. One of the first we discovered is Matt's Freshwater Cave (Taborosi, 2006). Located at a depth of 11 m, it is large enough and discharges enough water to make orientation in it challenging, due to distorted visibility caused by the mixing of the fresh water with the surrounding seawater. The cave's single, oval chamber extends into the cliff and contains several distinct discharge points. A similar cave just north of Ague Cove opens at a depth of 12 m at the base of a coastal cliff and appears to be an intermittent spring. Local divers report freshwater discharge so intense that swimming into the cave against the current is difficult. When the authors of this article visited the cave, no freshwater discharge was identified. The most impressive submarine cave spring is known to local SCUBA divers as the Northern Caves. The cave discharges so much freshwater that orientation in its narrow horizontal slit-like entrance is difficult because of very reduced visibility due to water mixing. Once past the entrance and a chamber full of flooded stalactites, divers can ascend above the mixing zone and enter a freshwater body. From there, it is possible to continue into another chamber and actually reach the water surface, exiting from a freshwater pool in an inland cave with an entrance in the jungle. The cave has many World War II artifacts left by Japanese stragglers hiding here after the war. It is the only inland cave known on Guam where a human can traverse the subaqueous connection between its freshwater pool and the ocean.

6. Conclusions

Our observations that coastal discharge is focused and localized rather than distributed and diffuse support the hypothesis that aquifers on uplifted young carbonate islands and coasts are most likely multiple porosity aquifers. Specifically, we believe that the overall plumbing system of the aquifer is consistent with the concept of triple-porosity systems of karst aquifers (cf., Halihan et al., 1999;

White, 1999; Worthington, 1999), but that in contrast to continental karst aquifers, in which conduit flow dominates, these island aquifers exhibit substantial contributions from all three components: diffuse, fracture, and conduit flow. All three flow components are associated with characteristic discharge features observed at the coastline. To the extent that discharge styles reflect internal flow pathways, this association suggests that all three components are important to internal flow as well, particularly near the coastal zone.

References

- Contractor, D. N., and J.W. Jenson, 2000, Simulated Effect of Vadose Infiltration on Water Levels in the Northern Guam Lens Aquifer: *Journal of Hydrology*, **229**, 232–254.
- Gamble, D.W., D. Taborosi, J.E. Mylroie, J.W. Jenson, J.L. Carew, J.M., U. Jocson, J. Mylroie, and D.T. Vann, 2003, The Use of Water Temperature to Characterize Groundwater Discharge of a Coastal Fracture on Guam, U.S.A.: *Journal of Coastal Research*, **19**, 462–471.
- Halihan, T., J.M. Sharp Jr., and R.E. Mace, 1999, Interpreting flow using permeability at multiple scales: *Special Publication No. 5: Karst Modeling*, Karst Waters Institute, Charlottesville, VA, p. 82–96.
- Hoffman, S.M., J.W. Jenson, D.C. Moran, G.R. W. Denton, H.R. Wood, and H.L. Vacher, 2007, Background fluorescence in Guam's coastal waters, *WERI Technical Report No. 121*, Mangilao, Water & Environmental Research Institute of the Western Pacific, University of Guam, 48 p.
- Jenson, J.W., J.M.U. Jocson, and H.G. Siegrist, 1997, Groundwater discharge styles from an uplifted Pleistocene island karst aquifer, Guam, Mariana Islands: *The Engineering Geology and Hydrology of Karst Terranes*, Beck, B.F. and Stephenson, J.B., eds, Balkema, Springfield, MO, p. 15–20.
- Jenson, J.W., Keel, T.M., Mylroie, J.R., Mylroie, J.E., Stafford, K.W., Taborosi, D., and Wexel, C., 2006, Karst of the Mariana Islands: The interaction of tectonics, glacioeustasy and fresh-water/sea-water mixing in island carbonates: *Geological Society of America Special Paper 404*, p. 129–138.
- Jocson, J.M.U., 1998, Hydrologic model for the Yigo-

- Tumon and Finegayan subbasins of the Northern Guam Lens Aquifer, Guam: M.S. Thesis, University of Guam, Mangilao, 95 p.
- Jocson, J.M.U., J.W. Jenson, and D.N. Contractor, 1999, Numerical Modeling and Field Investigation of Infiltration, Recharge, and Discharge in the Northern Guam Lens Aquifer, *WERI Technical Report No. 88*, Mangilao, Water & Environmental Research Institute of the Western Pacific, University of Guam, 22 p.
- Jocson, J.M.U., J.W. Jenson, and D. N. Contractor, 2002, Recharge and Aquifer Response: Northern Guam Lens Aquifer, Guam, Mariana Islands: *Journal of Hydrology*, **260**, 231–254.
- Keel, T.M., J.E. Mylroie, J.R. Mylroie, and J.W. Jenson, 2005, The cave and karst of Rota Island, Commonwealth of the Northern Mariana Islands: *Journal of Cave and Karst Science*, **67**, 187.
- Moran, D.C., and J.W. Jenson, 2004, Dye trace of groundwater from Guam International Airport and Harmon Sink to Agana Bay and Tumon Bay, *WERI Technical Report No. 97*, Mangilao, Water & Environmental Research Institute of the Western Pacific, University of Guam.
- Mylroie, J.E., J.W. Jenson, D. Taborosi, J.M.U. Jocson, D.T. Vann, and C. Wexel, 2001, Karst features on Guam in terms of a general model of carbonate island karst: *Journal of Cave and Karst Studies*, **63**, 9–22.
- Stafford, K.W., T.M. Keel, J.E. Mylroie, J.W. Jenson, and J.R. Mylroie, 2003, Eogenetic karst development in the Mariana Islands: Aguijan, Rota, and Tinian: *Journal of Cave and Karst Studies*, **65**, 188.
- Taboroši, D., 2000, Karst Inventory of Guam: M.S. thesis, University of Guam, Mangilao, 221 p.
- Taboroši, D., 2006, Karst inventory of Guam, Mariana Islands, *WERI Technical Report No. 112*, Mangilao, Water and Environmental Research Institute of the Western Pacific, University of Guam, 197 p.
- Taboroši, D., 2008, Coastal Guam Aerial Imagery Database: Island Research & Education Initiative & Water and Environmental Research Institute of the Western Pacific, v. available at www.weriguam.org/v2/interface/.
- Taboroši, D., J.W. Jenson, and J.E. Mylroie, 2005, Karst features of Guam, Mariana Islands: *Micronesica*, **38**, 17–46.
- Vacher, H.L., and J.E. Mylroie, 2002, Eogenetic karst from the perspective of an equivalent karst medium: *Carbonates and Evaporites*, **17**, 182–196.
- White, W.B., 1999, Conceptual Models for Karstic Aquifers, *Special Publication No. 5: Karst Modeling*, Karst Waters Institute, Charlottesville, VA, p. 11–16.
- Worthington, S.R.H., 1999, A comprehensive strategy for understanding flow in carbonate aquifer *Special Publication No. 5: Karst Modeling*, Karst Waters Institute, Charlottesville, VA, p. 17–29.

PRECIPITATION OF PHREATIC OVERGROWTHS AT THE WATER TABLE OF METEORIC-MARINE MIXING ZONES IN COASTAL CAVE SYSTEMS: A USEFUL TOOL IN SEA LEVEL CHANGE RECONSTRUCTION

PAOLA TUCCIMEI¹, MICHELE SOLIGO¹, JOAN J. FORNÓS², ANGEL GINÉS², JOAQUIN GINÉS²,
BOGDAN P. ONAC^{3,4}, IGOR M. VILLA^{5,6}

¹*Dipartimento di Scienze Geologiche, Università "Roma Tre", Roma, Italia.*

²*Departament de Ciències de la Terra, Universitat de les Illes Balears, Palma de Mallorca, Spain.*

³*Department of Geology, University of South Florida, Tampa, FL 33620, USA.*

⁴*Babeş-Bolyai University, Cluj/"Emil Racoviță" Institute of Speleology, Cluj, Romania.*

⁵*Universität Bern, Institut für Geologie, Bern, Switzerland.*

⁶*Dipartimento di Scienze Geologiche e Geotecnologiche, Università di Milano - Bicocca, Milano, Italia.*

Precipitation of carbonates within coastal karst caves at the present-day water table has been extensively documented in Mallorca and Sardinia. These depositions frequently occur either as calcite rafts floating at the brackish waters surface or, more commonly, as horizontal bulbous belts of calcite or aragonite overgrowths that develop over the walls of the caves or whatever suitable support is available (stalactites, stalagmites, columns) in correspondence to current sea level. The water table in the coastal caves is at about the same elevation as sea level and undergoes analogous daily fluctuations. Therefore, the present-day precipitates, known as Phreatic Overgrowths on Speleothems (POS), mark the current position of sea level and provide an excellent analogue for interpreting past bands of precipitates now located above or below modern sea level. With the aim of testing the strength of POS as indicators of present and past sea levels, some overgrowths, now located at current water table in Mallorca, have been dated by U-series methods. The results indicate that the phreatic carbonate precipitation took place sometimes between ~2,800 and ~600 years BP. The discovery of a drowned prehistoric construction, at a depth of 1 m below current sea level in a cave from the same area, and its temporal chronological attribution to about 3,700 - 3,000 years BP seem to be in good agreement with the obtained age of calcite precipitation at the current water table. The geographical distribution of POS is restricted to some very specific geochemical environments, always related to coastal caves characterized by low-range tidal fluctuations.

1. Introduction

Reconstructions of Quaternary sea-level changes based on speleothems mainly rely on two kinds of evidences: dating of submerged stalagmites (currently located below sea level) and chronological studies of Phreatic Overgrowths on Speleothems (POS), deposited in correspondence with present-day or ancient sea level stands. Within this framework, drowned speleothems are used to measure past falls and rises of sea level, whereas present-day growing POS provide the height and duration of modern sea level stillstands.

Current precipitation of carbonates at the water table within coastal karst caves has been extensively documented in Mallorca Island (western Mediterranean), as shown by the presence of calcite rafts and, more specially, in the form of horizontal bulbous belts of calcite or aragonite precipitates (Pomar et al., 1976, 1979; Ginés et al., 1981). Older horizontal belts of POS appear on the walls of many coastal caves, suggesting a clear connection of these overgrowths

with ancient (Late Pleistocene) water table positions. During the last three decades, several programmes of U-series dating and stable isotope analyses were carried out on many samples of these past overgrowths. The age consistency has demonstrated that precipitation took place repeatedly during several stabilisations of the water table corresponding to high or low sea stands, mainly correlated with Oxygen Isotope Stages (OIS) 9, 7, and 5 (Ginés and Ginés, 1974; Pomar et al., 1987; Ginés et al., 2001; Tuccimei et al., 1997, 2006).

Although these cave deposits are rather rare worldwide, they are of growing interest within coastal karst settings, especially in Mallorca (Hennig et al., 1981; Vesica et al., 2000; Fornós et al., 2002a; Csoma et al., 2006). The abbreviated term POS emphasises the chemical nature of carbonate precipitation produced just at the water table (Vesica et al., 2000; Tuccimei et al., 2006), in contrast to other more or less bulbous biogenic overgrowths, frequently found in many coastal caves (Harmon et al., 1978; Bard et al., 2002; Antonioli et al., 2004; Suric et al., 2007),

known as Marine Overgrowths on Speleothems (MOS). Probably MOS have a wider geographic distribution than POS, owing to the great number of karst caves captured by littoral erosion and invaded by sea-waters all over the world. However POS are much more accurate registers of sea stands, precisely recording sea level elevations and fluctuation ranges.

It appears that POS geographic distribution is restricted to specific geochemical environments, always related to coastal caves affected by small-range tidal fluctuations. Well-developed POS are common in the coastal caves of western Mediterranean area, namely Mallorca and Sardinia (Mucedda et al., 1997; Tuccimei et al., 2007). But the updated scattered distribution of present-day POS only extends farther to bulky overgrowths in Minamidaito caves (Nansei islands, Japan, Pacific Ocean) described by Urushibara-Yoshino (2003) and to tiny calcite coatings of Freshwater Cave (Christmas Island, Australia, Indian Ocean) reported by Grimes (2001). Further research is required in order to confirm the presence of POS in Dalmatia, Cuba and islands in the Pacific Ocean.

Up to now, few efforts have been devoted to POS Holocene samples (overgrowths located around the current surface of phreatic pools) probably because of their presumed subactual chronology. In this paper, some preliminary U-series datings of subactual POS are presented, in order to verify the stratigraphic consistency of age data and strengthen the use of POS as sea level indicators.

2. Investigated caves

Investigation was focused on two coastal caves located in the Migjorn karst region (southern and eastern Mallorca) that forms a postorogenic carbonate platform, fringing a basement mainly built by Mesozoic rocks folded during the alpine orogeny. Both caves are developed within very porous calcarenites of the Upper Miocene (Tortonian) Reef Complex (Pomar et al., 1996; Fornós et al., 2002b).

Cova de Cala Varques A is located only a few metres from the eastern coast of Mallorca, 5 km SW of Portocristo village (Manacor municipality). It belongs to a system of three neighbour caves interconnected through underwater passages with a total development of approximately 600 m in length, 250 m of which consist of submerged chambers and galleries (Gràcia et al., 2000). Breakdown features are dominant inside the cave, along with a variety of carbonate speleothems. In this cave, the presence of bulky calcite overgrowths along the margins of extensive brackish water pools is noteworthy (Fig. 1a).

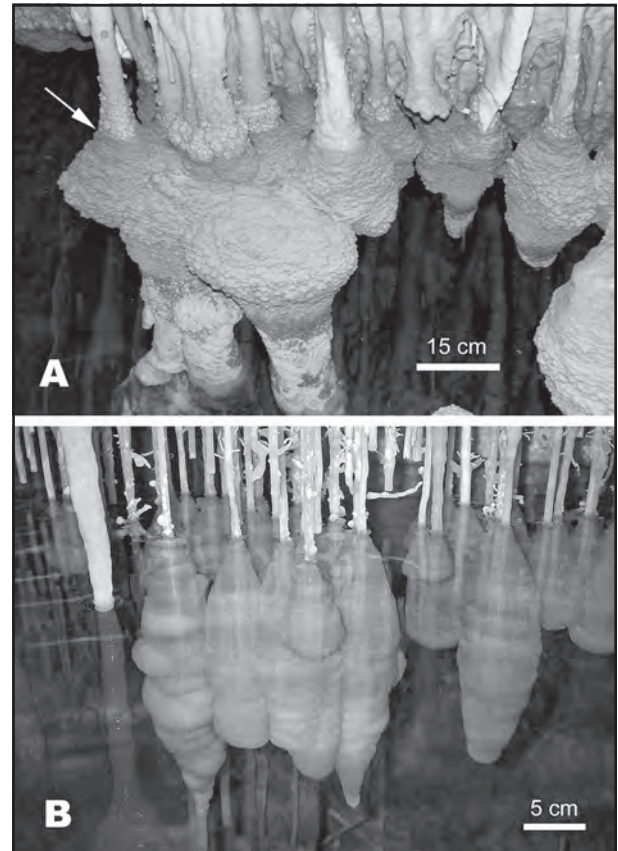

Figure 1: View of the carbonate crystallisations occurring at the surface of brackish pools in the studied caves. A: calcite belt of POS in Cova de Cala Varques A (Manacor). B: aragonite belt of POS from Cova des Pas de Vallgornera (Llucmajor); the thickest part of the overgrowth band corresponds to the mean sea level.

Cova des Pas de Vallgornera is the longest cave in Mallorca, with a documented development exceeding nowadays 60 km. The only entrance to the system is an artificial opening, and is located in the southern coast of the island within Llucmajor municipality. It consists of an impressive maze of galleries and chambers developed at two main levels (Merino et al., 2006, 2007, 2008; Ginés et al., 2008), the lower being partially drowned by brackish waters. The genesis of the cave system is complex, including besides dissolution linked to mixing coastal processes, a possible contribution of hypogenic karstification processes. Speleothems decoration is exuberant and breathtaking throughout the cave, showing a noteworthy richness and variety of crystalline forms. Among the carbonate precipitates, aragonite deposits formed at the surface of the subterranean brackish pools are remarkable. They include abundant delicate calcite stalactites having their tips coated by smooth yellowish aragonitic overgrowths (Fig. 1b).

3. The Phreatic Overgrowths on Speleothems (POS)

The lowest parts of caves developed in Migjorn area are drowned by phreatic brackish waters as a consequence of Holocene sea level rise (Ginés and Ginés, 2007). The control that sea level exerts on the coastal water table is very clear since daily oscillations of sea surface are recorded inside the caves (Rodés, 1925). The maximum fluctuation range of the water table (tides and barometric variations) in Cova de Cala Varques A, located only some metres from the shoreline, is around 50 cm. This change of water table elevation is significantly reduced farther away from the coast.

Carbonate precipitation is active at the surface of brackish waters favoured by CO₂ degassing, where calcite rafts are frequently formed at the water-air interface of the cave pools. Moreover, bulky horizontal bands of phreatic carbonate crystallisations (Fig. 1) are deposited over whatever suitable support is available (stalactites, stalagmites, columns, cave walls, etc.), related to present-day sea level (Pomar et al., 1979). As a rule, the maximum thickness of these precipitates is located in the middle of the crystallisation belt, gradually decreasing upward and downward (Fig. 2). The total height of the overgrowth (50 cm) is reached at Cova de Cala Varques A and corresponds to the current daily oscillation range of sea level in this cave, placed very close to the shoreline. In Cova des Pas de Vallgornera, whose pools are situated 500 m inland, the vertical extension of POS belt is slightly smaller, around 30 cm.

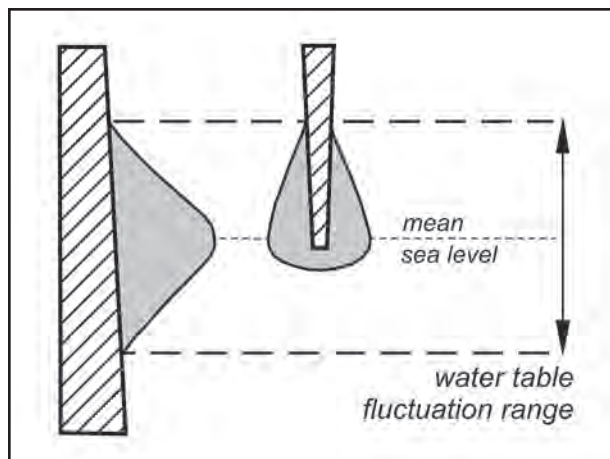

Figure 2: Sketch showing a vertical profile of POS developed over two geometrically different supports.

The peculiar bulky shape of POS deposits has a rather simple statistical explanation, according to which the maximum thickness corresponds to the more frequent position of the water table (the mean sea level) and the gradual reduction of

crystallisation's width is due to the progressively less frequent sea position at higher and lower elevations. The described morphology develops when the POS inner support (a column or stalagmite, for example) embraces the entire fluctuating range of the water table (Fig. 2). The overgrowth shape can be substantially different when POS develops on small stalactites, whose tips do not penetrate deep enough below the pool surface. In this situation the precipitation is abruptly truncated where the support is not reached by sea level oscillations and flat-bottomed bulky overgrowths form (Fig. 2). The surface texture of these speleothems varies depending on mineralogical and crystallographic characteristics. Commonly, they present rough surfaces with small protuberances when the overgrowth consists of calcite crystals, whereas the surfaces of aragonite overgrowth deposits are smooth. In both cases, the laterally growing carbonate layers are clearly visible if samples are halved, particularly in the bulky calcite overgrowths.

Two speleothems –encrusted by carbonate phreatic overgrowths– were collected at the current water table in Cova de Cala Varques A (sample VA-D1) and Cova des Pas de Vallgornera (sample VL-D3). Both samples are vadose dripping speleothems (that had grown during previous sea level low stands) covered with evident phreatic crystallisations, presumably postglacial in age, consisting of a thick calcite overgrowth (VA-D1) or a smooth aragonite coating (VL-D3), respectively.

4. Dating results discussion

Fourteen samples have been dated from speleothem VA-D1 (Cova de Cala Varques A), two from the inner vadose support and other twelve from the calcite phreatic overgrowth (Fig. 3); the latter have been drilled along several transects oriented transversal or parallel to the growth axis. Five other samples have been dated from speleothem VL-D3 (Cova des Pas de Vallgornera) along or perpendicular to the growth layers (Fig. 3).

Obtained age data show that phreatic overgrowth precipitation in the two caves are clearly postglacial and occurred approximately over the same time-period (Tuccimei et al., 2008), although there is a slight shift in the beginning and interruption of deposition. In particular, calcite deposition corresponding to sample VA-D1 occurred from 2,800 to about 1,100 years BP, whereas the aragonite in sample VL-D3 took place about 2,000 to 600 years BP. This discrepancy might be a result of variations in the chemical compositions and saturation indices of pool waters, probably related to the different distance of the two caves from the coastline.

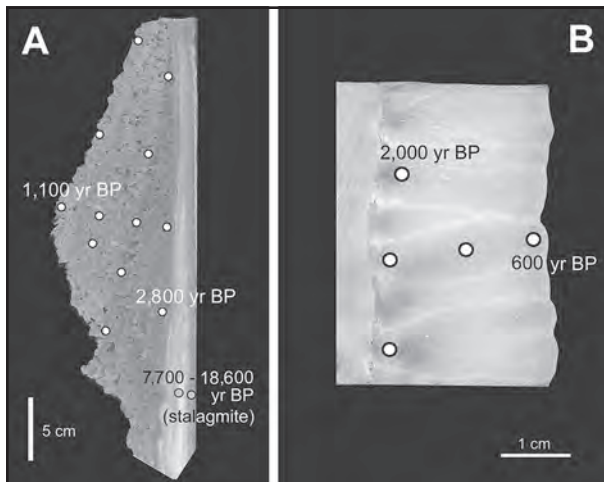

Figure 3: Vertical sections of the studied speleothems showing the location and ages of dated samples. A: speleothem VA-D1 from Cova de Cala Varques A (Manacor). B: speleothem VL-D3 from Cova des Pas de Vallgornera (Llucmajor).

The deposition of the vadose stalagmite in the inner part of speleothem VA-D1 began about 18,600 years BP and continued at least until 7,700 years BP (Fig. 3). These dates are consistent with the deposition of dripping water speleothems during the sea level low stand linked to the last glaciation.

The ages of POS from Cova de Cala Varques A and Cova des Pas de Vallgornera show to be stratigraphically consistent, demonstrating that the chemical system remained substantially closed since deposition; hence no diffuse phenomena of leaching or preferential dissolution occurred. It is worth noting that the ages of phreatic overgrowth precipitation represents a minimum time interval for sea stand at that elevation, since the chemical properties of cave water can change during sea stands, causing the carbonate deposition to cease.

The age spatial distribution of VA-D1 phreatic samples also gives indication of a slight possible change of sea level during carbonate precipitation (from 2,800 to 1,100 years BP). Calcite precipitation seems to be first limited to the lower portion of the speleothem (lowest ten centimetres) and then it apparently extended upwards. This could be interpreted as a slow, but progressive rise of sea level during the deposition of the overgrowth, as supported by archaeological evidences.

5. Other archaeological evidences of Holocene sea level

In the entrance chamber of Cova Genovesa –a cave located only a few kilometres away from Cova de Cala Varques

A—a drowned prehistoric construction lies 1 m below the present-day water table (Gràcia et al., 2003). This archaeological remain consists of a stone-built pass that, at the moment of its construction, allowed to cross the first chamber pool without getting wet (Fig. 4); it is a 7 m long stepping stones path, composed by at least 14 artificially aligned big rock blocks, some of them more than 1 m across. The occurrence of a past sea level at a depth of around 1 metre is further strengthened by a horizontal staining, observable at both sides of the construction, as well as along the submerged cave walls.

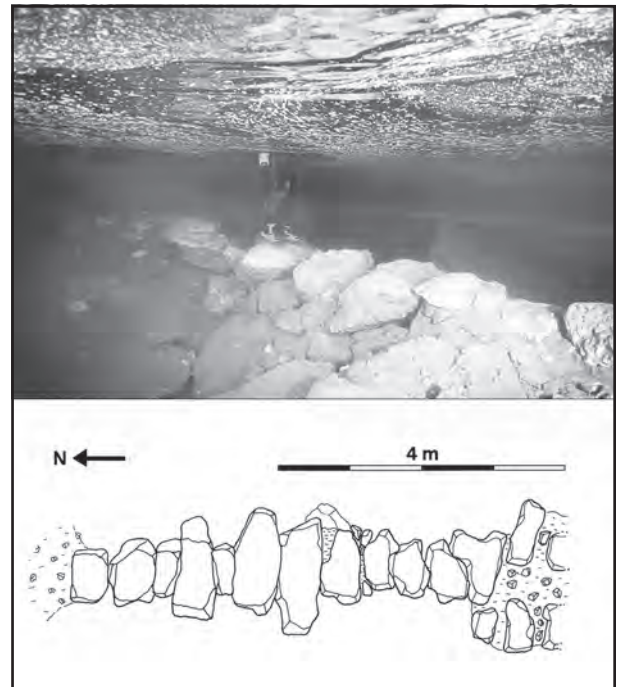

Figure 4: Underwater picture and schematic map of the stone-built pass existing in Cova Genovesa (Manacor). It allowed to cross in dry conditions the entrance pool of the cave, even though currently submerged at a depth of -1 m. The use of the cave corresponds presumably to the final stage of Navetiform culture (~ 3,700 – 3,000 years BP).

The prehistoric use of the cave is not clear; there are no proofs of burial activities, and certainly water supply must have been one of the main needs for the ancient communities. The scarce recovered pottery dates back to Bronze Age (Gràcia et al., 2003) and chronologically constrains the use of the cave at the final stage of the Navetiform culture (~ 3,700 – 3,000 years BP).

Combining archaeological data (Alcover et al., 2001) and isotope chronology of POS, it is possible to recognise a relative sea level lowstand at about -1 m, around 3,700 to 3,000 years BP, followed by a rise of sea level, with a

successive stabilization at present elevation, from ~3,000 years BP until today.

6. Conclusions

Subactual phreatic overgrowths on speleothems deposited at current sea level represent a useful present analogue that allows the tracing of past sea level lowstands and highstands, as documented from littoral caves of Mallorca and Sardinia. Stratigraphic age consistency obtained in the study of Holocene POS (both calcitic and aragonitic) confirms the optimistic research perspectives formerly envisaged on the basis of geomorphological observations and isotopic studies.

The POS have clear advantages when compared to other proxies used for Quaternary sea level reconstructions, like corals, vadose submerged speleothems, and marine overgrowths on speleothems (MOS). In this sense, POS alignments mark with an excellent accuracy the elevation of the sea at the time of their precipitation, whereas all the other types of carbonate precipitates give only an estimation of lower or upper limit reached by the sea level. Furthermore, when compared with other obvious morphological indicators of sea level as wave-cut notches or platforms, POS have the advantage to be precisely datable with U-series method.

Up to now POS are frequently found in the coastal caves of western Mediterranean area, as well as in few restricted locations in Pacific and Indian oceans. Additional research is required in order to confirm the presence of POS in Eastern Mediterranean basin, the Caribbean Sea or other islands of the Pacific Ocean. If their occurrence is confirmed, research in global sea level changes could take advantages of this useful tool.

Acknowledgements

This work was partially supported by the research fund of Ministerio de Ciencia e Innovación – FEDER, CGL2006-11242-C03-01/BTE.

References

- Antonioli, F., Bard, E., Potter, E.K., Silenzi, S., and Imbrota, S. (2004) 215-ka History of sea-level oscillations from marine and continental layers in Argentarola Cave speleothems (Italy). *Global and Planetary Change*, 43, 57–78.
- Alcover, J.A., Ramis, D., Coll, J., and Trias, M. (2001) Bases per al coneixement del contacte entre els primers colonitzadors humans i la naturalesa de les Balears. *Endins*, 24, 5–57.
- Bard, E., Antonioli, F., and Silenzi, S. (2002) Sea-level during the penultimate interglacial period based on a submerged stalagmite from Argentarola Cave (Italy). *Earth and Planetary Science Letters*, 196, 135–146.
- Csoma, A.E., Goldstein, R.H., and Pomar, L. (2006) Pleistocene speleothems of Mallorca: implications for palaeoclimate and carbonate diagenesis in mixing zones. *Sedimentology*, 53, 213–236.
- Fornós, J.J., Gelabert, B., Ginés, A., Ginés, J., Tuccimei, P., and Vesica, P.L. (2002a) Phreatic overgrowths on speleothems: a useful tool in structural geology in littoral karstic landscapes. The example of Eastern Mallorca (Balearic Islands). *Geodinamica Acta*, 15, 113–125.
- Fornós, J.J., Pomar, L., and Ramos-Guerrero, E. (2002b) Balearic Islands. In *The Geology of Spain*, Gibbons, W. and Moreno, T. (Eds.), The Geological Society, London, p. 327–334.
- Ginés, A., and Ginés, J. (1974) Consideraciones sobre los mecanismos de fosilización de la Cova de sa Bassa Blanca y su paralelismo con formaciones marinas del Cuaternario. *Bolletí de la Societat d'Història Natural de les Illes Balears*, 19, 11–28.
- Ginés, A., and Ginés, J. (2007) Eogenetic karst, glacioeustatic cave pools and anchialine environments on Mallorca Island: a discussion of coastal speleogenesis. *International Journal of Speleology*, 36:2, 57–67.
- Ginés, J., Ginés, A., and Pomar, L. (1981) Morphological and mineralogical features of phreatic speleothems occurring in coastal caves of Majorca (Spain). *Proc. 8th Int. Congress Speleol.*, Bowling Green, 2, 529–532.
- Ginés, J., Fornós, J.J., Ginés, A., Gràcia, F., Delitala, C., Taddeucci, A., Tuccimei, P., and Vesica, P.L. (2001) Els espeleotemes freàtics de les coves litorals de Mallorca: canvis del nivell de la Mediterrània i paleoclima en el Pleistocè Superior. In *El Canvi Climàtic: passat, present i futur*. Monografies de la Societat d'Història Natural de les Balears, 9, 33–52.
- Ginés, J., Ginés, A., Fornós, J.J., Gràcia, F., and Merino, A. (2008) Noves observacions sobre l'espeleogènesi en el Migjorn de Mallorca: els condicionants litològics

- en alguns grans sistemes subterranis litorals. *Endins*, 32, 49–79.
- Gràcia, F., Clamor, B., and Lavergne, J.J. (2000) Les coves de Cala Varques (Manacor, Mallorca). *Endins*, 23, 41–57.
- Gràcia, F., Jaume, D., Ramis, D., Fornós, J.J., Bover, P., Clamor, B., Gual, M.A., and Vadell, M. (2003) Les coves de Cala Anguila (Manacor, Mallorca). II: La Cova Genovesa o Cova d'en Bessó. Espeleogènesi, geomorfologia, hidrologia, sedimentologia, fauna, paleontologia, arqueologia i conservació. *Endins*, 25, 43–86.
- Grimes, K.G. (2001) Karst features of Christmas Island (Indian Ocean). *Helictite*, 37:2, 41–58.
- Harmon, R.S., Schwarcz, H.P., and Ford, D.C. (1978) Late Pleistocene sea level history of Bermuda. *Quaternary Research*, 9, 205–218.
- Hennig, G.J., Ginés, A., Ginés, J., and Pomar, L. (1981) Avance de los resultados obtenidos mediante datación isotópica de algunos espeleotemas subacuáticos mallorquines. *Endins*, 8, 91–93.
- Merino, A., Mulet, A., and Mulet, G. (2006) La Cova des Pas de Vallgornera: 23 kilòmetres de desenvolupament topogràfic (Llucmajor, Mallorca). *Endins*, 30, 29–48.
- Merino, A., Mulet, A., Mulet, G., Croix, A., and Gràcia, F. (2007) La Cova des Pas de Vallgornera (Llucmajor, Mallorca): 40 kilòmetres de desenvolupament topogràfic. *Endins*, 31, 101–110.
- Merino, A., Mulet, A., Mulet, G., Croix, A., and Gràcia, F. (2008) La Cova des Pas de Vallgornera (Llucmajor, Mallorca): Alcanza los 55 kilòmetres de desenvolupament topogràfic. *Endins*, 32, 33–42.
- Mucedda, M., Loru, R., and Montanaro, L. (1997) Grotte di Capo Caccia. La Celere Editrice, Alghero, 134 p.
- Pomar, L., Ginés, A., and Fontarnau, R. (1976) Las cristalizaciones freáticas. *Endins*, 3, 3–25.
- Pomar, L., Ginés, A., and Ginés, J. (1979) Morfología, estructura y origen de los espeleotemas epiaquáticos. *Endins*, 5–6, 3–17.
- Pomar, L., Rodríguez-Perea, A., Fornós, J.J., Ginés, A., Ginés, J., Font, A., and Mora, A. (1987) Phreatic speleothems in coastal caves: a new method to determine sea-level fluctuations. In Late Quaternary sea-level changes in Spain. Museo Nacional de Ciencias Naturales, Madrid, p. 197–224.
- Pomar, L., Ward, W.C., and Green, D.G. (1996) Upper Miocene reef complex of the Llucmajor area, Mallorca, Spain. In Models for carbonate stratigraphy from Miocene reef complexes of the Mediterranean regions, Franseen, E., Esteban, M., Ward, W.C., and Rouchy, J.M. (Eds.) *SEPM Concepts in Sedimentology and Paleontology* 5, p. 191–225.
- Rodés, L. (1925) Los cambios de nivel en las cuevas del Drach (Manacor, Mallorca) y su oscilación rítmica de 40 minutos. *Mem. Acad. Cienc. Art. Barcelona*, 19:7, 207–221.
- Suric, M., Jalzic, B., and Petricoli, D. (2007): Submerged Speleothems - Expect the unexpected. Examples from the Eastern Adriatic Coast (Croatia). *Acta Carsologica*, 36:3, 389–396.
- Tuccimei, P., Ginés, J., Ginés, A., and Fornós, J.J. (1997) Th/U dating of sea level-controlled phreatic speleothems from coastal caves in Mallorca (western Mediterranean). *Proc. 12th Int. Congress Speleol., La Chaux de Fonds*, 1, 37–42.
- Tuccimei, P., Ginés, J., Delitala, M.C., Ginés, A., Gràcia, F., Fornós, J.J., and Taddeucci, A. (2006) Last interglacial sea level changes in Mallorca island (Western Mediterranean). High precision U-series data from phreatic overgrowths on speleothems. *Zeitschrift für Geomorphologie N.F.*, 50:1, 1–21.
- Tuccimei, P., Fornós, J.J., Ginés, A., Ginés, J., Gràcia, F., and Mucedda, M. (2007) Sea level change at Capo Caccia (NW Sardinia) and Mallorca (Balearic Islands) during oxygen isotope substage 5e, based on Th/U datings of phreatic overgrowths on speleothems. In *Geomorfologia litoral i Quaternari. Homenatge a Joan Cuerda Barceló*. Pons, G.X. and D. Vicens (Eds.), Mon. Soc. Hist. Nat. Balears, Palma de Mallorca. 14, p. 121–135.
- Tuccimei, P., Soligo, M., Ginés, J., Ginés, A., Fornós, J.J., Kramers, J., and Villa, I.M. (2008) Speleothem

precipitation at the water table of Holocene meteoric-marine mixing zones in Mallorca (Western Mediterranean). Strengths and limitations as palaeoenvironmental and palaeoclimatic archives. EGU, General Assembly 2008, Geophysical Research Abstracts, Wien, 10. A-02145. 2 p.

Urushibara-Yoshino, K. (2003) Karst terrain of raised coral islands, Minamidaito and Kikai in the Nansei Islands of Japan. *Zeitschrift für Geomorphologie N.F. Suppl.* 131, 17–31.

Vesica, P.L., Tuccimei, P., Turi, B., Fornós, J.J., Ginés, A., and Ginés, J. (2000) Late Pleistocene Paleoclimates And Sea-Level Change In The Mediterranean As Inferred From Stable Isotope And U-Series Studies Of Overgrowths On Speleothems, Mallorca (Spain), *Quaternary Science Reviews*, 19, 865–879.

SPELEOGENESIS IN CENOZOIC LIMESTONES ON A PASSIVE CONTINENTAL MARGIN SOUTHEASTERN AUSTRALIA.

SUSAN WHITE

Environmental Geoscience, Latrobe University, Bundoora Vic 3068 Australia, susanwhite@netspace.net.au

Extensive areas of Cenozoic marine and eolianite limestones occur on the passive continental margin of southeastern Australia. The Gambier Karst Province in the western Otway Basin consists of four relatively small areas of intensive karst development in Miocene marine limestone (Naracoorte, Glenelg River, Drik Drik, and Mount Gambier), interspersed amongst extensive areas with limited karst. Syngenetic karst developed within the dune ridges of the Pleistocene Bridgewater Group dunes, is widespread across the province where favorable conditions occur.

The groundwater conditions of a coastal environment combined with highly porous and permeable limestones resulted in a distinctive karst. Across the karst province phreatic conduits formed in coastal environments on an upwarping continental margin, where specific localised conditions created enhanced solutional conditions over relatively short time periods in the early to mid Pleistocene. Falling sea levels throughout the rest of the Pleistocene controlled subsequent modification of this karst. Superimposed over the cave development in the marine limestones, is the development of syngenetic karst in the Pleistocene carbonate strandline ridges of the Bridgewater Group eolianites. Many karst features are similar to those seen in carbonate island karst such as The Bahamas. However the geological setting of southern Australia throughout the Pleistocene is such that significant differences are evident.

This paper will discuss the features, processes of formation and timing of the karst of the western Otway Basin. This brings new insights into coastal karst conditions in a continental margin setting that has consequences for the speleogenetic concepts in coastal settings.

1. Introduction

The Cenozoic limestones of Australia include extensive areas of Tertiary marine and Pleistocene dune carbonates in coastal and near coastal areas in the southern half of Australia. The dunes occasionally extend inland for up to over 100 km and overlie significant Tertiary marine carbonates that provide their source material. The karst features in the marine and eolian lithologies have some characteristics in common and others distinctly different. The features and processes of the karst of the Gambier Karst Province in the western Otway Basin (Fig. 1) typify the Cenozoic karst areas in Australia.

In Australia, there have been numerous studies of karst landscape evolution in well-cemented and well-jointed Paleozoic limestones, e.g. Webb et al. (1992), but the porous Cenozoic limestones have received only limited attention, even though they cover a substantially greater area. Most Cenozoic limestone karst studies have focussed on the Nullarbor karst, e.g. Jennings (1967) with some limited studies of the eolianite karst, e.g. Jennings (1968); White (1994); Grimes (2002, 2006).

These carbonate areas experience a range of climates: Arid, Temperate and Mediterranean. The most extensive karst areas, including the Otway Basin, experience the dry summers and cool to mild, wet winters of Mediterranean climatic conditions (Csb modified Köppen system).

2. Location and Geological Setting

The western Otway Basin lies on the southern Australian passive continental margin that formed during the Mesozoic continental break-up and seafloor spreading between the Australian and Antarctic plates. Extensive rifting, which controls the underlying geometry of the basin and the sediment accumulation, occurred from the mid-Jurassic to mid-Cretaceous and faulting continued into the late Cenozoic. The uplift of the Southern Australian continental margin continues today.

The Otway Basin is broadly divided into eastern and western sections. The western Otway Basin contains two karst provinces: the Gambier (western) and Port Campbell (eastern) Karst Provinces; the Naracoorte and Glenelg River karst areas lie within the former (Fig. 1). The diachronous

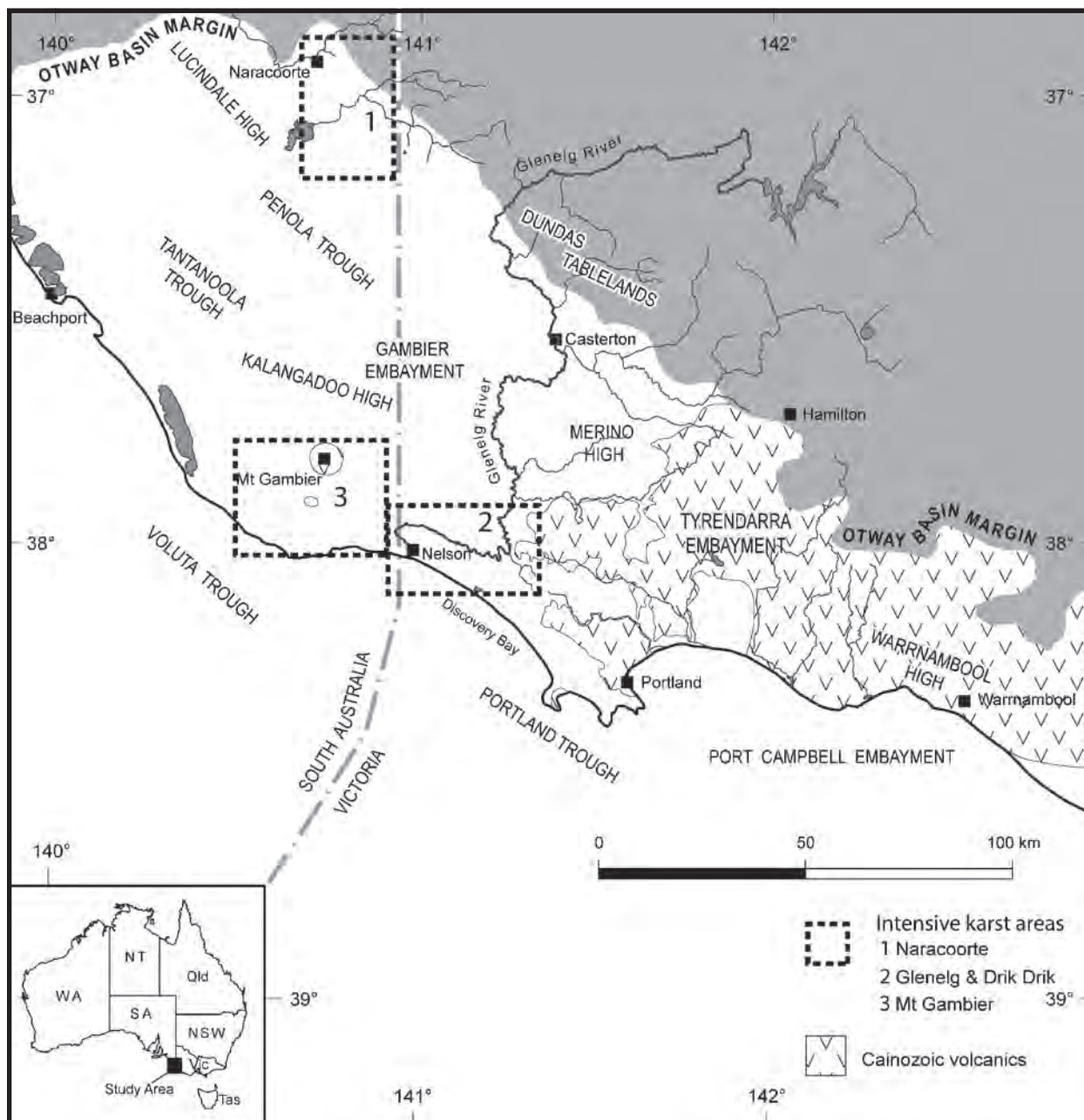

Figure 1: Western Otway Basin and Gambier Karst Province.

boundary between them, which is obscured by Cenozoic basalt flows, is defined by a lithological change from the Gambier Limestone to its lateral non-karstic equivalent, the Gellibrand Marl. Marker (1975) and Grimes et al. (1995) described the South Australian section of the Gambier Karst Province, and the former first established the area as an important karst province. The karst province comprises extensive areas where cave and karst development is limited, interspersed with areas of atypical intensive karst development in both Oligo-Miocene cool water limestones, and the overlying Pleistocene Bridgewater Group dunes (White, 2005).

The carbonate-rich final Late Miocene transgression was followed by a tectonic event at the end of the Miocene (Dickinson et al., 2002), subaerial exposure and associated karstification at the top of the Tertiary Limestones (Holdgate and Gallagher, 2003) and Pliocene mixed clastic-carbonates. The Oligo-Miocene Gambier Limestone is a fossiliferous carbonate of varying thickness with high variability in cementation, grain lithology and porosity. The Mid to Late Miocene Port Campbell Limestone outcrops extensively along the coastal margin of the Victorian part of the Otway Basin, but is not found west of the Kanawinka and Jones Ridge Faults and is not present in the Gambier Karst Province.

During the Pleistocene, as the sea regressed, the west-northwest to northwest-trending bioclastic carbonate beach, barrier and sub-parallel calcareous dune complexes were deposited unconformably over extensive areas of the western Otway Basin in a high-energy coastal environment (Kenley, 1988; Orth, 1988; Trounson, 1985) during the sea-level fluctuations spanning most of the Pleistocene. Dune building occurred from at least 1.3 Ma through to present times, depending on suitable conditions. The dunes young towards the coast and their height and degree of separation decrease inland. The gradual uplift of the coastal plain west and south of the Kanawinka Fault (Fig. 1) resulted in a punctuated, time-transgressive eolianite sequence associated with sea-level high stands spanning most of the Pleistocene (Belperio et al., 1995; Coulson, 1940; Cupper et al., 2003; Kenley, 1971). The dunes are characterised by large-scale dune cross bedding with occasional, horizontally bedded beach sediments. Bridgewater Group dune calcarenites are well-sorted, fine- to medium-grained, laminated bioclastic carbonate sands composed clasts of carbonate and quartz and are derived from reworking of the underlying Tertiary sediments (Boutakoff, 1963; White 2005). The chemical composition of Bridgewater Formation is typically variable (Kenley 1971; Coulson 1940; White, 1984, 2005) and although variably cemented with calcite where the karst develops, the dunes are better cemented e.g. Bats Ridge, western Victoria (15 to 30% cement) (White, 1984), Naracoorte up to 34.0 %, Drik Drik 12% - 24% (White, 2005).

The area was subjected to Quaternary volcanism from the Pliocene (Cupper et al., 2003) to the 4 to 5 ka eruptions of Mount Gambier and Mount Schank (Sheard, 1995). Post Mid Pleistocene tectonic movements have substantially affected the landscapes, with the termination of some dunes against fault escarpments, e.g. at Drik Drik. Non-calcareous interdune facies are important in restricting vertical recharge and diversion of surface water into the dune ridges.

3. Characteristics of Karst in Cenozoic Limestones

The areas of atypical karst development, such as Naracoorte and the Glenelg River area, are where the joint-controlled caves reflect the northwest-southeast jointing pattern. The large caves in the Gambier Karst Province are extensive systems developed in the Miocene Gambier Limestone especially at Naracoorte, whereas along the Glenelg River, the largest surface drainage system in the entire western Otway Basin, the caves are less numerous and smaller. There are extensive fossiliferous clastic deposits in several caves at Naracoorte and Glenelg River. The cenotes are a common feature of the Mt Gambier part of the basin where water

tables are relatively high. The dunes in specific localities show a range of syngenetic karst features, including caves, e.g. Bats Ridge, Codrington, Mumbannar, Puralka, Ardno, Monbulla, Avenue Range, Snake Hill (Berryman and White, 1995; Kenley, 1988; Grimes et al., 1995; White, 1997, White, 2000).

Karst processes and the resultant features are dominated by the nature of the limestones. These features included high primary porosity and permeability, highly variable cementation and the coastal location during major cave development. This development occurred over a relatively long time frame compared to similar limestones elsewhere in the world. They may or may not be influenced by jointing, the presence of which is highly variable. Both these limestones are generally poorly lithified but their responses to karst forming processes, despite some strong similarities are not identical. The limestones vary in texture and lithology and just as not all massive limestones are equally soluble, the situation is similar on poorly consolidated limestones. Both the marine carbonates and the calcareous dunes show the development of an indurated layer, horizontal mazes and single conduit caves, domed chambers and extensive modification by collapse. Solution pipes, bell hole development and limited speleothem deposition, especially moonmilk, are common in both.

The caves range from simple single passages or chambers to complex multi-level caves, and from a few metres to over 4 km in length. Cave passages are dominated by linear single conduits, with some branchwork passages and loose mazes present, but no tight or 3-dimensional mazes. Many passages are modified by collapse; domed passages are common and extensive rubble piles occur throughout the cave systems. Some caves show roughly rectangular passage cross sections because the roof beds are relatively well cemented and stable, however many caves retain remnants of the original phreatic elliptical cross section. Large domes occur in several caves; some are due to collapse but others are original solutional chambers with little or no breakdown rubble on the floors and diagnostic solutional ceiling features, e.g. bell holes (Fig. 2). Important Pleistocene vertebrate deposits occur in a number of caves e.g. Victoria Fossil Cave (Naracoorte), McEachern Cave (Glenelg River). Other caves show impressive sand cones. In the Pleistocene dunes the major difference is the single level development of the caves; the other features are very similar.

The passage orientation of the karst features in the two types of limestone is distinctive. Cave passages in the dune limestones show a spread of passage directions whereas



Figure 2: Bellholes in roof of Wet Cave (U 10), Naracoorte.

cave passages in the Tertiary limestones are more obviously directional; commonly either NE-SW or NW-SE which reflects the jointing patterns of the limestones. The conduit development was dominated by the jointing pattern, and passages are oblique to the orientation of the dune ridges e.g. East Naracoorte Range, and their direction was not determined by coastline orientation.

As both host rocks are weakly cemented, collapse has been a major process modifying many of the large cave chambers and passages producing chambers with either domed or flat, bedding-plane-controlled roofs. Large collapse domes commonly obscure much of the original solutional cave shape, although the general linear or maze pattern of most caves can still be identified. Collapse material may almost completely fill the cavity leaving only limited "inclined fissures", with little of the original solutional passage remaining. In some dune areas (e.g., Codrington), an entire cave has collapsed resulting in the complete displacement of the cavity resulting in a surface of jumbled rocks.

The presence of both solution pipes and bell holes (avens)

is characteristic of caves in both dune limestone (Jennings 1968) and the older marine limestones. Soil-filled pipes not associated with caves are common and are sometimes associated with rhizomorphs (calcified small root structures), which are quite fragile and easily destroyed by erosion. Solution pipe entrances are vertical and usually smooth sided cylindrical tubes varying from 0.2 to 3.5 m in diameter. These penetrate from the surface and intersect cave passages. They can be found as single pipe entrances or as multiple closely spaced pipes. They typically have a thinly cemented rim. Solution pipes are a distinctive and widely reported feature of the softer more permeable limestones, e.g. Cretaceous Chalk of Europe (Lamont-Black and Mortimore, 1999). Four methods of concentrating the flow have been proposed: stem-flow, tree root influence, water accumulating on surface hollows, and uneven cementation of the hardpan. These methods are not mutually exclusive, and all four may occur at one locality to produce solution pipes (Grimes, 2004). Bell holes are cylindrical cavities with vertical long axes, varying between 0.3 to 1 m in diameter and 0.5 to 1.0 m deep, tapering upwards (Fig. 2). They are a widespread feature of ceilings of caves in Cenozoic limestone in southern Australia, are not found on walls and are not associated with jointing in the cave ceilings. Examples of the tops of bell holes are found on ceilings, subject to collapse, indicate that they are a solutional feature predating collapse. Bell holes have been explained in several ways, (see Lauritzen and Lundberg, 2000), however more work is required to document their extent and understand their formation.

Random intersection of solution pipes and bell holes may explain the rare solution pipes with constrictions, which have previously been explained as more resistant lithology despite no apparent lithological differences. The relationship between the downward development of the solution pipes and the bell holes is unclear but are probably not related and the two features formed independently. They are not associated here with tropical conditions (as discussed in Tarhule-Lips and Ford, 1998), and have formed during the glacial/interglacial conditions of the Pleistocene.

Speleogenesis

In the areas of intensive karst development in the Gambier Karst Province, the karst is mainly developed in the variably (but generally highly), permeable and porous flat-lying Tertiary Gambier Limestone. The cave development was controlled by the north-northwest and east-northeast joint orientations and coastal groundwater conditions. Earlier tectonic movements determined the joint directions and distribution. The position of the sea level controlled the configuration of the watertable and groundwater flow directions, and as sea level dropped, due to the Pleistocene

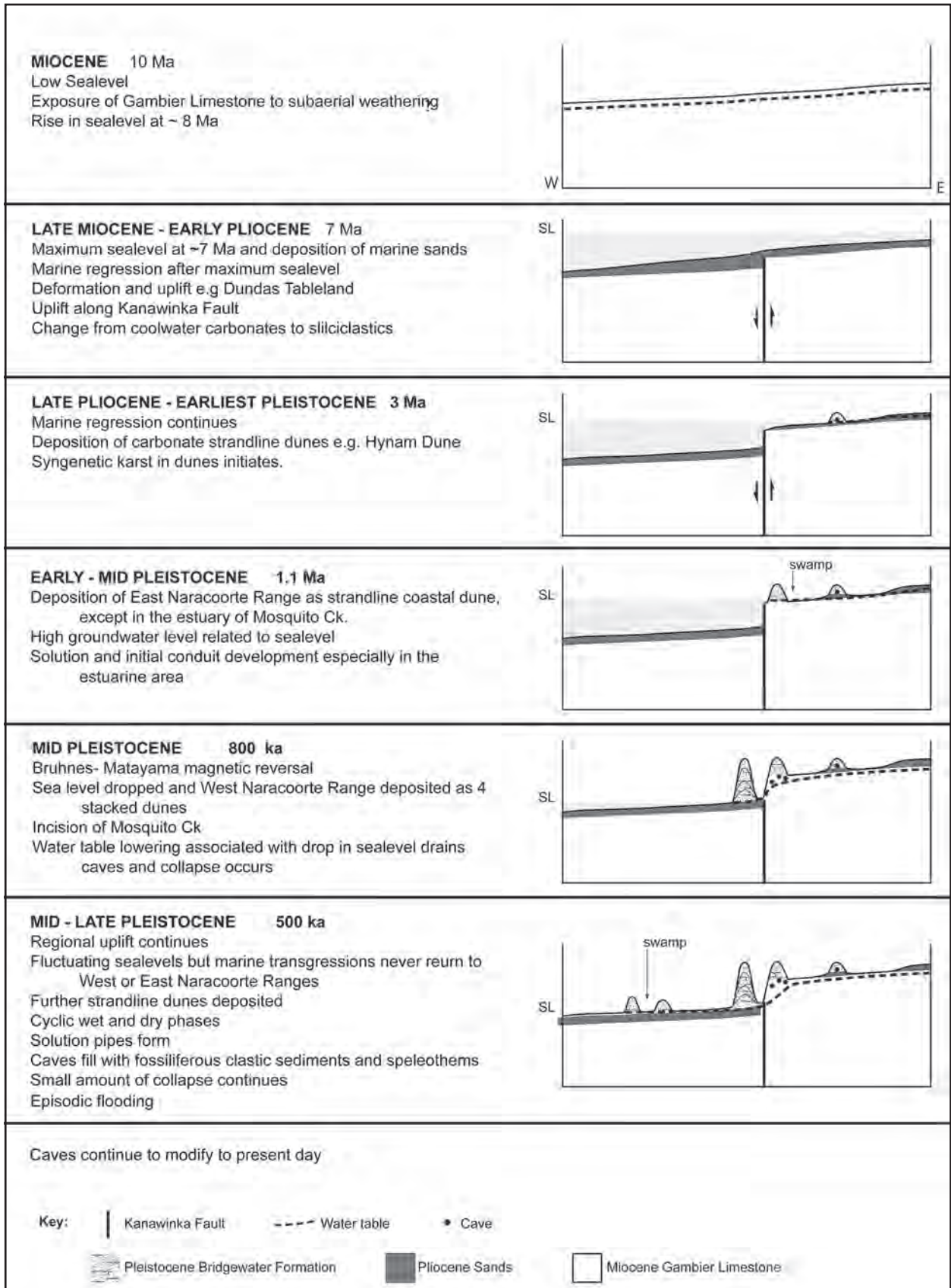

Figure 3: Stages of landscape development, Naracoorte.

sea level fluctuations combined with regional upwarping, the watertable fell and the caves drained. Syngenetic caves formed in the Pleistocene dunes under the developing cap rock as the dunes lithified (Grimes, 2006; White, 2000, White, in press).

Using published dates it is possible to develop the landscape evolution for the Gambier Karst Province. The karst phreatic conduits formed in coastal environments on an upwarping continental margin, where specific localised conditions created enhanced solutional conditions at specific times from the Mid Pleistocene. Subsequent modification of the karst was controlled by falling sea levels throughout the rest of the Pleistocene. At Naracoorte, karstification occurred after the Early Pliocene uplift on the Kanawinka Fault zone, but before sea level fell between ~750 and 800 ka when the West Naracoorte Range was deposited (Huntley & Prescott, 2001). The main phreatic conduit formation occurred between ~1.1 Ma and 800 ka when sea level was at ~70 m above present. Prior to 1.1 Ma, the area was flooded by the sea and karstification was minimal (White, 2005). Cave formation occurred in a flank margin situation, either near the top of the watertable and/or along the freshwater/seawater halocline. Maximum conduit development occurred ~400 to 500 m inland from the highwater line, probably in estuarine or coastal dune back-swamp conditions. Two levels of cave occur at ~61 m and ~70 m above present sea level, formed during two sea level still-stands. Large phreatic solutional chambers crossing both levels, e.g. Wet Cave (U 10) and Cathedral Cave (U 12), formed under phreatic conditions and solution may have been enhanced by CO₂ rising from depth from nearby eruption of Newer Volcanic basalts. When sea levels dropped between ~800 ka and 750 ka and the West Naracoorte Range was deposited (Huntley & Prescott, 2001), Mosquito Creek incised, collapse occurred and the caves sequentially drained. Although the caves were never completely flooded again, they were further modified by solution and collapse. The cyclical wet and dry conditions of the Mid to Late Pleistocene resulted in solution pipe formation, deposition of fossiliferous clastic sediments, precipitation of calcite speleothems, further collapse and the weathering of cave walls (White, 2005). Localised flooding deposited mud in the lower sections of a few caves. Minor modification continues to the present day (Fig. 3).

Conclusions

In the Gambier Karst Province the karst phreatic conduits formed in coastal environments on an upwarping continental margin, where specific localised conditions created enhanced solutional conditions over relatively

short time periods. Subsequent modification of the karst was controlled by falling sea levels throughout the rest of the Pleistocene. The karst province is characterised by four relatively small areas of intensive karst development (Naracoorte, Glenelg River, Drik Drik and Mount Gambier), interspersed amongst extensive areas with limited karst. The drowned cenote karst around Mount Gambier is very different from the other areas, despite similarities such as host lithology and joint development. In each case localized conditions of aggressive groundwater are related to increased groundwater flow combined with near coastal conditions, which have resulted in areas of concentrated karst in an otherwise sparsely karstified landscape. The sequence of the dunes younging towards the coast and hosting syngenetic karst is also a coastal karst phenomenon. The karst has been dominated by coastal conditions for over a million years.

Acknowledgements

Thanks to Ken Grimes who provided wise counsel on many aspects of Australian Cenozoic karst, Nicholas White who provided much of the field back up and funding, and John Webb for sage advice.

References

- Belperio, A.P. (Compiler), 1995. Quaternary. In: J.F. Drexel and W.V. Preiss (Eds), *The Geology of South Australia*. South Australia Geological Survey Bulletin 54. Adelaide, pp. 219–280.
- Berryman, S. & White, S. 1995. Karst in recent dunes, Codrington, Victoria. In Baddeley, G. (ed), *Vulcon Proceedings*, (20th ASF Conference), Victorian Speleological Association, Melbourne. pp. 23–31.
- Boutakoff, N. 1963. The geology and geomorphology of the Portland area. *Memoir 22*, Geological Survey of Victoria, Melbourne.
- Coulson, A. 1940. The sand dunes of the Portland district and their relation to the post-Pliocene uplift. *Proceedings of the Royal Society of Victoria*, 52(2): 315–335.
- Cupper, M.L., White, S. and Neilson, J.L. 2003. Quaternary: ice ages - environments of change. In: W.B. Birch (Ed), *Geology of Victoria*. Geological Society of Australia Special Publication 23, Geological Society of Australia (Victoria Division), pp. 337–359.
- Dickinson, J.A., Wallace, M.W., Holdgate, G., Gallagher,

- S.J. and Thomas, L. 2002. Origin and timing of the Miocene Pliocene unconformity in southeast Australia. *Journal of Sedimentary Research*, 72(2): 288–303.
- Grimes, K.G. 2002. Syngenetic and Eogenetic Karst: An Australian Viewpoint. in Gabrovsk, F. [ed] *Evolution of Karst: from Prekarst to Cessation*. Institut za raziskovanje kraska, ZRC SAZU, Postojna. pp. 407–414.
- Grimes, K.G. 2004. Solution pipes or petrified forests? Drifting sands and drifting opinions. *The Victorian Naturalist*, 121(1): 14–21.
- Grimes, K.G. 2006. Syngenetic Karst in Australia: a review *Helictite* 39(2): 27–38.
- Grimes, K.G., Hamilton-Smith, E. and Spate, A.P. 1995. South East Karst province of South Australia, Australian Caves and Karst Management Association.
- Holdgate, G.R. and Gallagher, S.J. 2003. Tertiary: a period of transition to marine basin environments. In: W.B. Birch (Editor), *Geology of Victoria*. Geological Society of Australia Special Publication 23, Geological Society of Australia (Victoria Division), pp. 289–335.
- Huntley, D.J. and Prescott, J.R., 2001. Improved methodology and new thermoluminescence ages for the dune sequence in south-east South Australia. *Quaternary Science Reviews*, 20: 687–699.
- Jennings, J.N., 1967. Some karst areas of Australia. In: J.N. Jennings and J.A. Mabbutt (Editors), *Landform Studies from Australia and New Guinea*. Australian National University Press, Canberra, pp. 256–292
- Jennings, J.N. 1968. Syngenetic Karst in Australia. In: Jennings, J.N. and Williams, P.W. *Contributions to the study of karst*. Res. Sch. Pac. St. A.N.U. 5: 41–110
- Kenley, P.R. 1971. Cainozoic geology of the eastern part of the Gambier Embayment, Southwestern Victoria. In: H. Wopfner and J.G. Douglas (Eds), *The Otway Basin of southeastern Australia*. Special Bulletin. Geological Surveys of South Australia and Victoria, pp. 89–155.
- Kenley, P.R. 1988. Quaternary - Southwestern Victoria. In: J.G. Douglas and J.A. Ferguson (Eds), *Geology of Victoria*. Geological Society of Australia, Victoria Division, Melbourne, pp. 365–379.
- Lamont-Black, J. and Mortimore, R.N. 1999. Predicting the distribution of dissolution pipes in the chalk of southern England using high resolution stratigraphy and geomorphological domain characterisation. In: B.F. Beck (Ed), *Hydrogeology and Engineering Geology of Sinkholes and Karst*. Balkema, Rotterdam, pp. 97–102.
- Lauritzen, S.-E. and Lundberg, J. 2000. Solutional and Erosional Morphology of Caves. In: A. Klimchouk, D. Ford, A. Palmer and W. Dreybrodt (Eds), *Speleogenesis: Evolution of Karst Aquifers*. National Speleological Society Inc., Huntsville, Alabama, U.S.A., pp. 408–426.
- Marker, M.E. 1975. The Lower Southeast of South Australia: A Karst Province. Department of Geography and Environmental Studies, University of Witwatersrand, Johannesburg, Occasional Paper No. 13, 68 pp.
- Orth, K. 1988. Geology of the Warrnambool 1:50,000 mapsheet. 86, Geological Survey of Victoria.
- Sheard, M.J. 1995. Quaternary Volcanic Activity and Volcanic Hazards. In: J.F. Drexel and W.V. Preiss (Eds), *The Geology of South Australia*. Bulletin 54. The Geological Survey of South Australia, pp. 264–268.
- Tarhule-Lips, R.F.A. and Ford, D.C. 1998. Morphometric studies of bell hole development on Cayman Brac. *Cave and Karst Science*, 25(3): 119–130.
- Trounson, L. 1985. Diagenetic and pedogenetic features of Quaternary dune and beach deposits of the southwest Victorian coast. M.Sc. Thesis, University of Melbourne, Melbourne, 139 pp.
- Webb, J.A., Fabel, D., Finlayson, B.L., Ellaway, M., Li, Shu and Spietz, H-P., 1992. Denudation chronology from cave and river terrace levels: the case of the Buchan karst, southeastern Australia. *Geological Magazine*, 129: 307–317.
- White, S. 1984. Karst landforms and their relationship

to Pleistocene dune ridges, Bats Ridge, Portland, Victoria. Unpublished MSc. Thesis, University of Melbourne, Australia.

- White, S. 1994. Speleogenesis in aeolian calcarenite: A case study in western Victoria. *Environmental Geology*, 23: 248–255.
- White, S. 1997. Karst of the Cainozoic limestones of the Otway Basin, Southeastern Australia, Fourth International Conference of Geomorphology. *Supplementi di Geografia Fisica e Dinamica Quaternaria*. Comitato Glaciologico Italiano, Italy, pp. 129–132.
- White, S. 2000. Syngenetic Karst in Coastal Dune Limestones: A Review In: A. Klimchouk, D. Ford, A. Palmer and W. Dreybrodt (Eds), *Speleogenesis: Evolution of karst aquifers*. National Speleological Society, Huntsville, Alabama, pp.234–23.
- White, S. 2005 Karst and Landscape Evolution in parts of the Gambier Karst Province, Southeast South Australia and Western Victoria, Australia. PhD thesis, Latrobe University, Australia.
- White, S. in press, Speleogenesis in Pleistocene Limestones of Southeastern Australia, Proceedings of the 14th Bahamas Symposium.

Symposium 8

LATEST ADVANCES IN KARST GEOPHYSICS

Arranged by:
Bruce Smith
Olivar Lima

DISCRIMINATION BETWEEN CAVES, OVERHANGS, AND LARGE VUGS USING LONG-WAVE INFRARED IMAGING

BARBARA ANNE AMENDE

Aerospace Corporation, 15049 Conference Center Dr., Chantilly, VA 20151

There has been a recent resurgence in interest for using thermal imaging to find cave entrances. The walls within the cave (and potentially near the entrance) are at or near the average annual temperature of the region. The surface rock, soil, and vegetation will warm and cool between day and night, as well as seasonally. At external temperature extremes, a strong thermal contrast may exist between cave entrances (moderate) and their surroundings (cold or hot).

Most studies thus far involve aiming a thermal imaging camera at a known cave entrances. Not surprisingly, the cave entrances are clearly anomalous in the scenes. To be useful for discovering new entrances, an understanding of the thermal characteristics of hillsides, cliffs, overhangs, small caves, and large vugs is necessary.

This study investigated karst features in the southern New Mexico desert. In the summer, no feature was recognizable at night or early morning when the air temperature was about 20–30° C. As the sun warmed the ground (and the air to >30° C), karst features became recognizable. Distinctions in the thermal anomalies between caves, overhangs, and large voids are subtle. This paper documents the recognition of the features, discusses the phenomenology, and makes recommendations regarding the best conditions for finding cave entrances.

1. Introduction

Caves, protected by overlying rock, have an interior temperature approximating the average annual temperature of the atmosphere at that location. The surface rock and vegetation warm and cool daily as well as seasonally.

The temperature of cave entrances and the surrounding terrain can be imaged in the thermal infrared portion of the electromagnetic spectrum (3–15 μm). Examples of this work include karst features in Puerto Rico and glacial crevasses in Greenland (Rinker, 1975), a large tunnel in Massachusetts (Best, et al., 1997), various caves (Thompson and Marvin, 2006), and abandoned mines (am Ende, 2008). The purpose of many of these studies is to show the utility of the technology for finding unrecognized underground entrances. Rinker (1975) and am Ende (2008) note that other features can have thermal variability and may be confused with actual cave or mine entrances.

The average annual temperature at Carlsbad Caverns National Park is 17° C. For the images taken during July, the heat of the day afternoon should have the greatest thermal contrast with a cave that is the average annual temperature in it's interior. The entrance zone will have mixing between interior temperatures and the outside air. On a summer afternoon, the ground surface will be warmed both by

contact with the warm air, and from sunlight falling directly on the ground surface. Theoretically, the ground could be shadowed from direct sunlight, but no natural process could cool the area below the air temperature other than the opening to a cave or cave-like feature that can be as low as the average annual temperature for the region. Interchange between cave air and outside air would moderate the thermal anomaly and

This study investigates whether small cave entrances can be recognized and the conditions under which overhangs, rock shelters, and karst features might be recognized or confused with true "caves."

2. Methods

A FLIR Systems ThermaCam S60 was used for this study. The camera has a 320 x 240 uncooled microbolometer focal plane array. The spectral range is 7.5–13 μm . The radiances measured by the ThermaCam are automatically converted to temperature data using parameters supplied by the user. The emissivity was set at 0.96 for all images. The temperature and humidity of the atmosphere were measured with a Kestrel 4500 weather meter.

A variety of karst features were imaged in the Guadalupe Mountains, New Mexico during July, 2008. The features

lie within an area with 6 km separating the farthest. Each feature was imaged at various times of day.

Figure 1 shows profiles of the features that were imaged. “DD” is a cave ~60 m long that is shaped like a U. The main entrance has two pillars creating three distinct “holes,” two of which are facing the camera direction. The third hole in the main entrance and the secondary entrance are oriented away from the camera at an angle. Only the main entrance zone of “DD” is shown in Figure 1. Four rock shelters were imaged: “MonoC,” “D,” “WYS,” and “AFF.” Features “A” and “B” are small alcoves formed under bedrock overhangs. Features “C” and “C2” are macro-sized karst vugs.

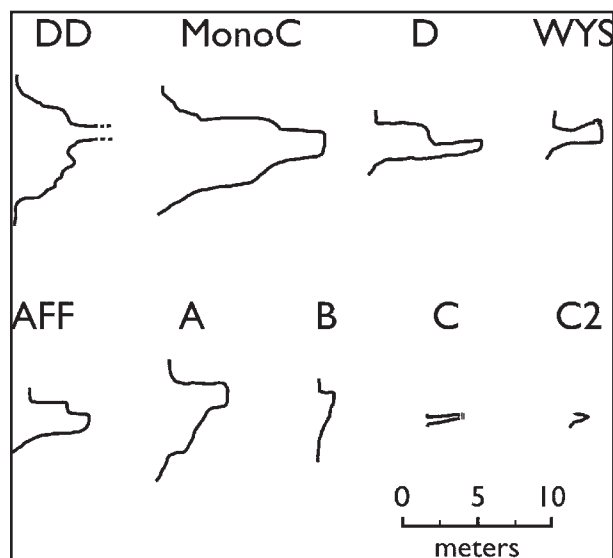

Figure 1: Profiles of the rock shelters, overhangs, macro-sized vugs, and the entrance area of one cave (“DD”). Geometry of these features is shown in Table 1.

Additionally, the main entrance to Carlsbad Cavern was imaged. A profile is not shown in Figure 1 because the scale of the entrance is vastly disproportionate to the others. The geometry for Carlsbad Cavern (“CaCa”) is listed in Table 1, along with the geometry for the other features.

Lastly, images were taken of two slightly enlarged joints that are very shallow and not amenable to surveying. These joints represent the opposite end of the size spectrum from a huge cave (Carlsbad Cavern).

3. Results

Figure 2 shows thermal images taken of each feature examined in this study. The top and third rows are scaled across the temperature range of 20–45° C. A matching series of the same images are shown in the second and bottom rows, but scaled across a narrower temperature interval. The images were taken in the late afternoon when thermal contract would be expected to be greatest. Each feature can be recognized by its relatively low temperature. Figure 3 shows series of images across 4 times of day (middle of the night, middle morning, late afternoon, and evening) for representative features.

4. Discussion

The ThermoCam automatically scales each image across the maximum and minimum temperatures in each scene. Comparing multiple images with different scales is confusing, especially since some images contain very cold sky. The top and third rows of images in Figure 2 have been scaled from 20–45° C, a range that covers ground temperatures for all images. The temperature range for the image can be easily modified in ThermoCam Researcher software. Many

Name	Volume (m ³)	Length (m)	Ent. Height (m)	Ent. Width (m)	Ave Ent. Diameter (m)	Length / Ave Ent. Diameter	Distance from ThermoCam (m)
CaCa	>500,000	44,305	20	25	23	1926	20
DD	375	60	1.0	2.4	2.7	22	330
MonoC	139	11	7.0	3.6	5.3	2.1	280
D	35	3.4	2.3	3.3	2.8	1.2	150
WYS	3.2	4.5/2.0	2.0/1.3	2.6/1.2	2.3/1.3	2.0/1.6	190
AFF	40	4.0	2.3	8.0	5.2	0.8	65
A	65	4.0	4.8	6.8	5.8	0.7	100
B	6	1.0	3.0	6.0	4.5	0.2	100
C	0.5	2.2	0.5	0.6	0.6	3.7	100
C2	0.2	0.9	0.5	1.0	0.8	1.1	100
Joints	N/A	N/A	N/A	N/A	N/A	N/A	70

Table 1: Geometry of karst features imaged in this study. Note that the volume of Carlsbad Cavern (“CaCa”) is crudely generalized and listed only to show that it has a volume several orders of magnitude larger than the other features examined.

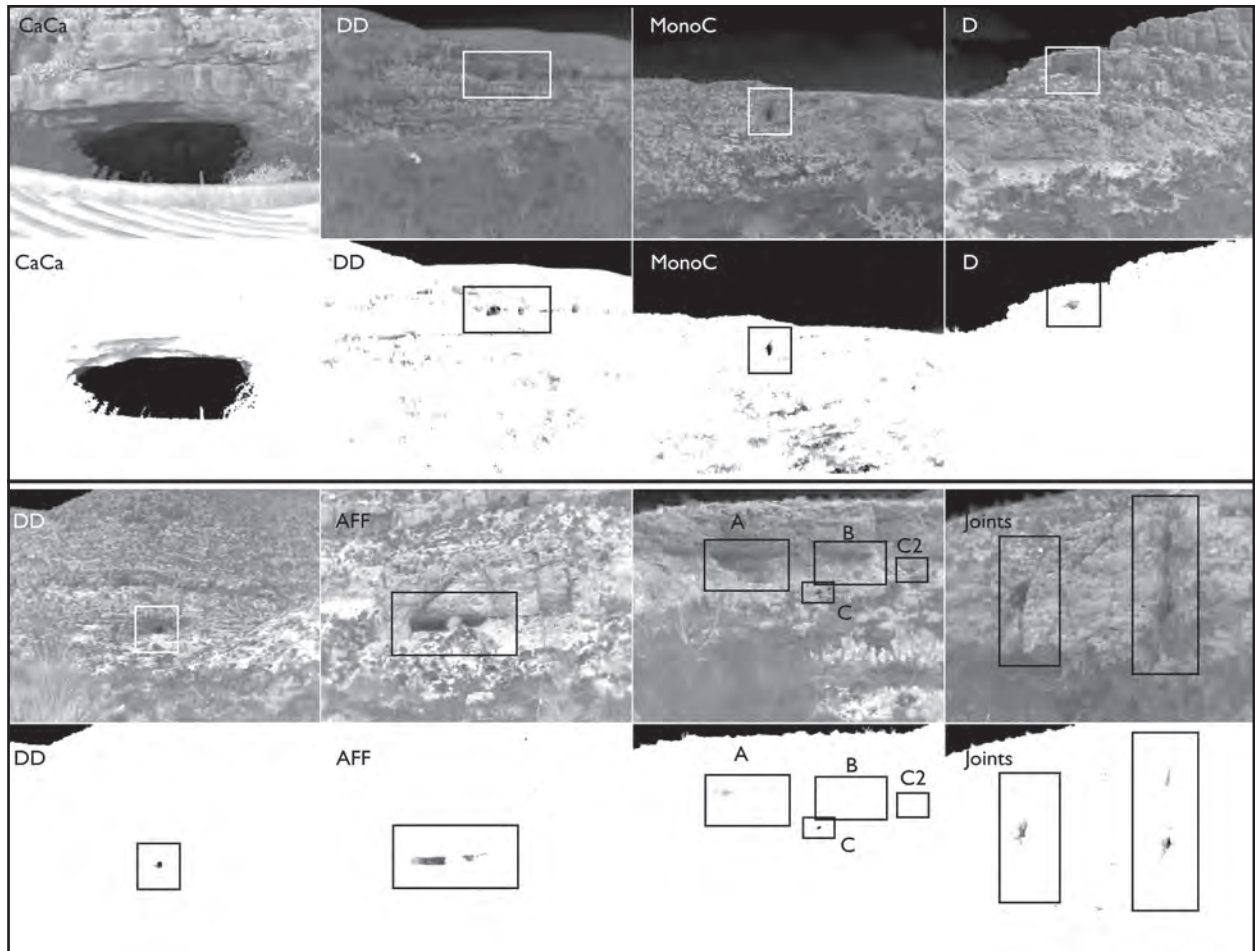

Figure 2: Thermal images of karst features taken from 3:55 to 4:33 P.M., July 15, 2008. The temperature was 36° C and the relative humidity was 34%. The top and third rows are scaled to a temperature range of 20–45° C. The second and bottom rows of images are identical to the top and third except that the images were scaled to a temperature range of 26.5–30° C.

temperature ranges were considered and a subjective choice of 26.5–30° C was selected as removing non-features such as blank rock walls and vegetation. Rock shelters tend to look much like caves, as do some small karst vugs, less than a meter in size. Only the deepest alcoves behind overhanging rock ledges appear cave-like in their thermal characteristics. However, various other features also show cool anomalies, including narrow, but relatively deep, enlarged joints and even vegetation in valleys and on hillsides.

As expected, at night in July, when the outside air temperature is 22° C, the karst features are nearly unrecognizable and images contain much thermal clutter (Figure 3, top row). By mid-morning, the temperature of 29–30° C is not high enough to be useful for caves (Figure 3, second row). In late afternoon, (temperature of 36° C), caves, rock shelters and karst vugs do stand out from surrounding terrain with minimal clutter (Figure 3, third row). In the evening, when the air temperature was 30° C, like the morning at the same air temperature the karst

features are not significantly visible.

To more fully understand the phenomenon, Table 1 contains geometry of the features examined in the study. In the afternoon imaging, the overhangs are the smallest length to entrance diameter ratios can be removed from the images by scaling the temperature range. However, average entrance diameter may not be an adequate measure. Rock shelter “AFF” has a length/average entrance diameter almost identical to overhang “A,” yet “A” can barely be recognized if at all, where “AFF” is distinctly visible (Figure 2). A ratio of the length to minimum entrance diameter may be more suitable for defining what geometry of feature is identifiable using thermal imaging.

Two large vugs (or small karst features) are present adjacent to overhangs “A” and “B” (Figures 2 and 3). Each has a volume <1 m³, the same entrance height, one with a width ~50% wider, and the other with a length just over twice as great. Despite similar geometries and sizes, the vug with

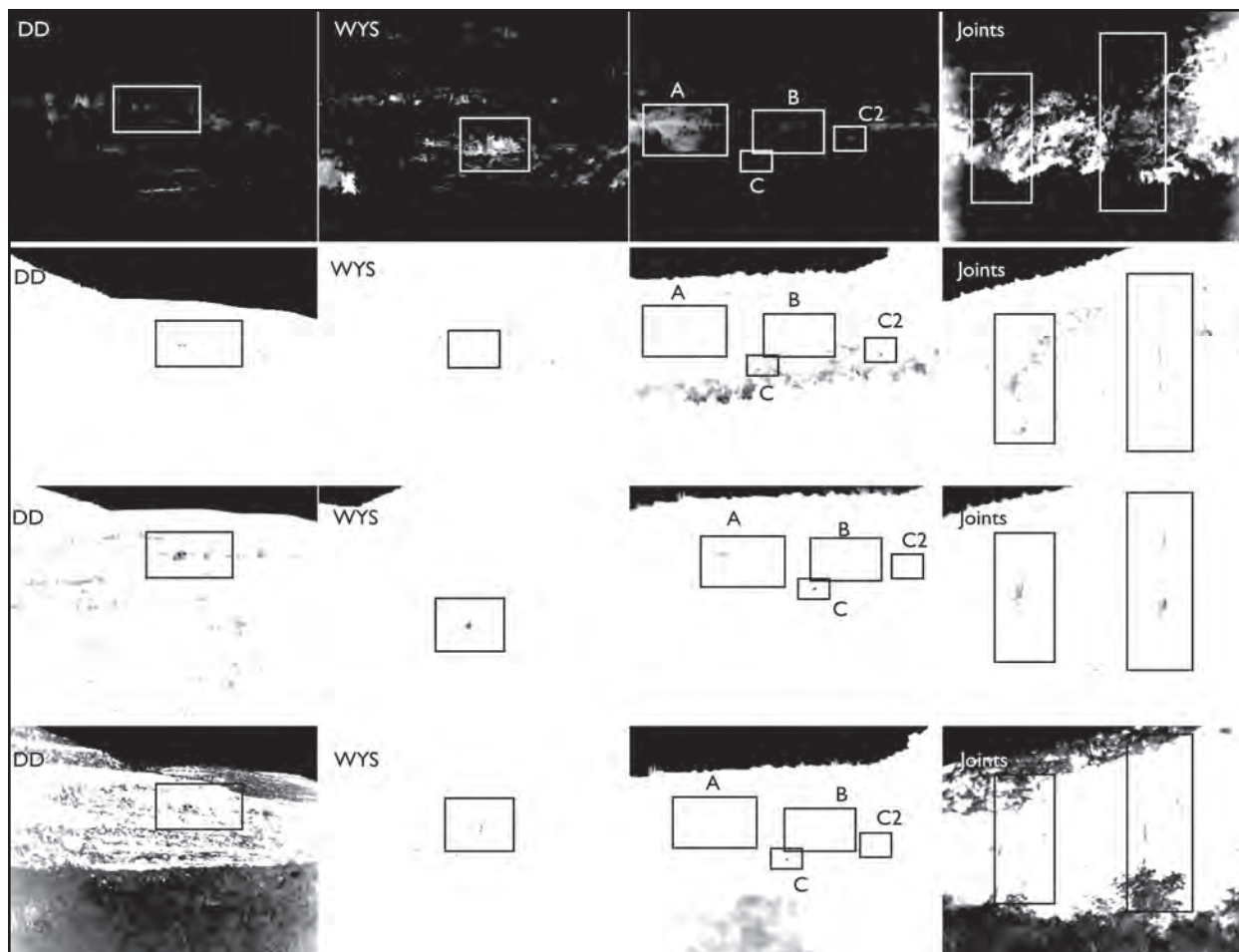

Figure 3: Thermal images of representative karst features. The top row was taken from 1:22-1:56 am, July 13, 2008. The temperature was 22° C and the relative humidity ranged between 74-83%. The images are scaled to a temperature range of 23–25° C. The second row was taken from 10:28–11:02 am, July 15, 2008. The temperature ranged from 29–30° C and the relative humidity ranged from 48-49%. The images are scaled to a temperature range of 23.5–25.5° C. The third row was taken from 3:55–4:33 pm, July 15, 2008. The temperature was 36° C and the relative humidity was 34%. The images are scaled to a temperature range of 25–30° C. The bottom row was taken from 6:25–6:54 pm, July 12, 2008. The temperature was 30° C and the relative humidity was 38%. The images are scaled to a temperature range of 25–27.5° C.

the smaller entrance and longer length is significantly more visible in thermal images.

5. Conclusions

Thermal imaging appears promising as a tool to find caves, but a good understanding of what constitutes a recognizable “cave” is yet to be determined. Scaling of the images is recommended, but a quantitative understanding of this process also is yet to be determined. It is likely that a total elimination of false alarms will never be possible, but thermal imaging will significantly narrow the regions to be investigated by humans.

References

- am Ende, B.A., 2008, Thermal Imagery as a Tool For Locating Abandoned Mines, National Association of Abandoned Mine Land Programs Conference, Durango Colorado, 15 pp.
- Best, R.G., P.J. Etzler, and J.D. Blohm, 1997, Characterization of Deep Tunneling Activity Through Remote-Sensing Techniques; *Journal of Environmental and Engineering Geophysics*, vol 2, pp 143–150.
- Rinker, J.N., 1975, Airborne Infrared Thermal Detection of Caves and Crevasses, *Photogrammetric Engineering and Remote Sensing*, vol 41, no. 11, pp 1391–1400.
- Thompson and Marvin, 2006, Experimental Research Using Thermography to Locate Heat Signatures from Caves, *InfraMation Proceedings*, 7 pp.

DETECTION OF SUB-TRAVERTINE LAKES USING ELECTRICAL RESISTIVITY IMAGING, SISTEMA ZACATÓN, MÉXICO

MARCUS O. GARY^{1,2}, TODD HALIHAN³, JOHN M. SHARP JR²

¹Zara Environmental, LLC, Buda, Texas

²The University of Texas at Austin, Jackson School of Geosciences, Austin, Texas

³Oklahoma State University, Boone Pickens School of Geology, Stillwater, Oklahoma

Sistema Zacatón, a karst area in northeastern Mexico known for deep phreatic shafts and hydrothermal water, also displays a unique travertine morphology. Some of the sinkholes are dry or contain shallow lakes with flat travertine floors; other deeper water-filled sinkholes have flat floors without the cone of collapse material commonly observed in these types of shafts. We tested the hypothesis that these floors have large water-filled voids beneath them using electrical resistivity imaging (ERI) to image both open cenotes and travertine-covered sinkholes. Three separate flat travertine caps were imaged using ERI; (1) La Pilita, which is partially open, exposing the structure of the cap over a deep water-filled shaft; (2) Poza Seca, which is dry and vegetated; and (3) Tule, which contains a shallow (<1 m) lake. A fourth line was run adjacent to the open cenote Verde. ERI at La Pilita tested the morphology of travertine surrounding this 110+ m deep cenote. The existence of some water-filled void spaces interpreted from ERI data was verified by SCUBA exploration and new voids are inferred. The ERI lines at Poza Seca demonstrated a thin (<2 to 4+ m) layer interpreted as the travertine cap with a conductive region (consistent with the resistivity of water) under the layer extending to at least 25 m depth beneath the cap. No lower boundary of the void is evident in the ERI data. The line at Tule also produced geophysical evidence of a large water-filled void beneath a thin (<2 to 4+ m) cap. A deep, higher resistivity layer indicates a flat lower boundary 45 m deep that may be a second cap, similar to one that exists at Verde. The ERI line adjacent to Verde hints at a deep water-filled cavity below this 45 m deep layer. These findings support the hypothesis of capped water-filled voids and may have implications for paleo-climate models of the late Pleistocene. The capped voids may provide habitats for anoxic microbial communities to evolve in isolated isothermal environments.

1. Introduction

Understanding the evolution and development of geologic features is an important factor when evaluating the flow of subsurface fluids in a karst aquifer. Hydrothermal karst systems are characterized by zones of carbonate dissolution and carbonate precipitation (DUBLYANSKY, 2000); and Sistema Zacatón, a hydrothermal cave system in northeastern México, displays these two zones in unique morphologies (GARY and SHARP, 2006; GARY et al, 2003). Here, immense collapse sinkholes (cenotes) have opened up to the surface, exposing vast voids that extend more than 319 meters below the shallow water table. Of the numerous open sinkholes located within Sistema Zacatón, approximately half of these features appear to have travertine that forms in the water table zone.

The unique morphology of the travertine deposits within many collapse features of Sistema Zacatón sparked the hypothesis that unique environments may exist. The flat-floored cenotes with a travertine bottom may be, in fact, travertine “caps” only meters thick covering expansive

underwater voids beneath the precipitated rock. Once large, open water-filled sinkholes, the calcite-rich, hydrothermal water could out-gas CO₂ and H₂S from the water and precipitate travertine growth along the walls at and around the water table. If water-levels remained stable, the travertine could grow radially inward until the geochemical conditions shift and halt the process, the water table elevation significantly changes or the entire sinkhole is closed off with a rock lid, limiting the precipitation process. In the case of Sistema Zacatón, the cenote La Pilita fits the first theory of halted precipitation with a 2–3 meter lid of mammary travertine partially covering a sinkhole that is over 110 meters deep. The “capping” process is incomplete at La Pilita, allowing for direct observation of both the forming travertine and access to the water-filled void beneath. While the opening is circular with a diameter of ~20 meters, the travertine deposit covers approximately 2.5 hectares. Five other flat floored cenotes exist in the area covered with either water or brushy vegetation. These locations do not support large trees common elsewhere in the area.

Methods to evaluate this type of travertine morphology include surface geophysics and drilling boreholes. The latter is complicated at Sistema Zacatón, and could potentially contaminate pristine microbial habitats. However, non-invasive geophysical techniques have proven successful at mapping karst features, including electrical resistivity imaging (ERI) (GARY et al, 2006; VOULLAMOZ et al, 2003; ROTH et al, 2002; ZHOU et al, 2002; SUMANOVAC and WEISSER, 2001), which has widespread applications in karst investigations. We have applied ERI as a primary geophysical tool to evaluate the morphology of travertine deposits in Sistema Zacatón, thus aiding in the geologic interpretation of karst development here.

2. Site Background

Sistema Zacatón is a diverse mixture of karst features that include: ramiform vadose cave passages, broad overland travertine flows, collapse dolines, deep phreatic shafts (>330 meters below water table), horizontal phreatic conduits (~300 meters), relict spring flow travertine, and numerous minor karst features throughout the system (rill

karren, epikarst, etc.). The most striking expressions of this karst system are the large circular sinkholes (cenotes) that dominate the immediate study area (Fig. 1). Upon initial inspection the sinkholes appear similar. However, substantial variation in water chemistry, rock type, and aqueous biological habitats reflect differences that make each poza unique. This wide distribution of characteristics raises many questions regarding the subsurface conduit system that connects or isolates each poza and provides the basis for the hypothesis of travertine caps that cover large phreatic void spaces.

Sistema Zacatón developed in Mid- to Late- Cretaceous carbonate rocks that were deposited as the ancestral Gulf of Mexico covered the area in a shallow sea (GOLDHAMMER, 1999). Following eastward regression of the sea, the limestone beds were exposed and uplifted as a result of late Laramide orogenic tectonics. The Zacatón cenotes lie in the foothills of the Sierra de Tamaulipas, which is the expression of the Tamaulipas Arch, a 200-kilometer long, domal anticline that formed in the Gulf coastal plain east of the fold and thrust belt of the Sierra Madre Oriental. The axial trace of this structure is immediately west of Sistema Zacatón and fractures parallel to the anticline are present around the sinkholes. Volcanic intrusions commenced in the southern Sierra de Tamaulipas in the Oligocene and continued through the Miocene. By the late Pliocene, substantial basalt flows and extrusive volcanic activity (andesites and basalts) became the dominant local geomorphic process (RAMIREZ FERNANDEZ et al, 2007; CAMACHO, 1993). The Aldama Volcanic Complex is immediately to the east of the study area, and it is inferred that this volcanic influence has had significant influence on the karstification of these Cretaceous rocks.

The aqueous geochemistry of Sistema Zacatón provides data that support the concept that travertine caps are significant fluid flow boundaries. Two pozas in particular reflect anomalous water characteristics, Tule and Verde. Tule has the largest diameter of all the pozas in Sistema Zacatón but generally has a water depth of only 1 meter. High sodium (533 mg/L), potassium (135 mg/L), chloride (245 mg/L), boron (1018 mg/L), and TDS (2746 mg/L) concentrations caused by evaporation. Tule may have high evaporation rates because the surface water of Tule is poorly connected to local groundwater circulation and the travertine cap isolates it from deeper fluids. Oxygen and hydrogen isotope analysis from Tule indicate that an increased rate of evaporation occurs, and Tule can act as a huge evaporation pan. Verde with a water depth of 45 meters also displays anomalous geochemistry. Its oxygenated water is quite different from

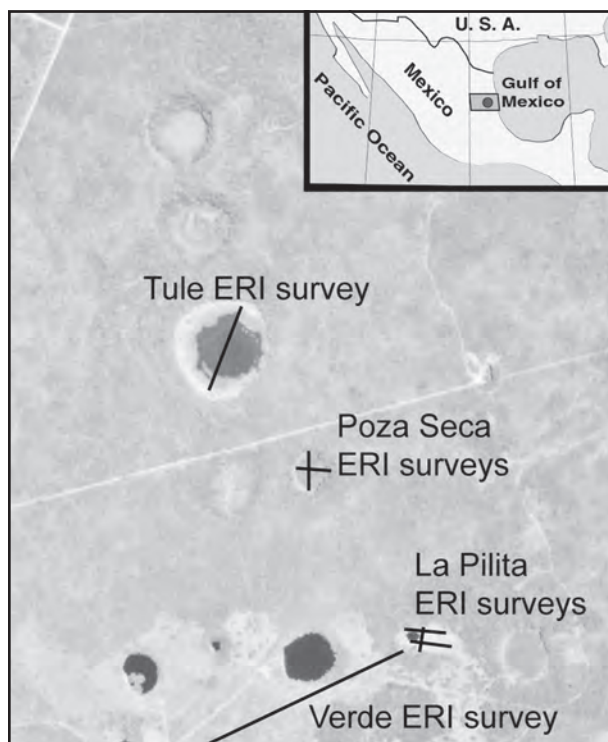

Figure 1: Upper right inset shows the general location of Sistema Zacatón in northeastern Mexico. The aerial photograph shows the major cenotes of Sistema Zacatón and locations of ERI survey transects at the four sites Tule, Poza Seca, La Pilita, and Verde. Other travertine capped sinkholes are evident above Tule and immediately right of La Pilita.

those of three other nearby deep anoxic cenotes. Verde's water temperature reflects seasonal changes as opposed to the stable, hydrothermal pattern seen at the deep cenotes of Zacatón, Caracol, and La Pilita. The floor of Verde is hypothesized to be travertine that formed when the water table was 45 meters lower, forming a significant barrier between shallow and deep groundwater (GARY and SHARP, 2006).

3. Methods

To test the hypothesis of travertine sealing lids existing over deep phreatic shafts, ERI was employed on the surface of the travertine floors of both the semi-open (La Pilita) and two sealed travertine deposits (Posa Seca and Tule). ERI could provide geophysical evidence of thin caps over phreatic shafts without disturbing the habitat of any potential microbial habitats that may exist beneath the caps. Data were collected over two field campaigns: January 2003 and June 2006.

The ERI data were collected using a 56-electrode system by clearing vegetation along lines cutting from the edges through the center of the travertine deposits. Stainless steel stakes were inserted and salt water was added around the stakes to provide a good connection to the surface. The data were collected using an AGI SuperSting R8/IP 8-channel resistivity meter. The data were processed using the Halihan-Fenstermaker method v. 4.0 (HALIHAN et al, 2005). Electrode spacings were 2 and 3 meters used for imaging of La Pilita, 2 meters for Posa Seca, and 5 meters for Tule. An additional line was collected with a spacing of 9 meters to evaluate the electrical stratigraphy away from the sinkholes near the cenote Verde (Fig. 1). These data are presented as contoured pseudosections in units of ohm-meters. The modeled electrical resistivity values have been normalized so the lower values representing water-filled voids have been calibrated to match values of fluid electrical resistivity. This was accomplished by measuring the specific conductance of water in open, water-filled cenotes and also in small seeps in the floor of Posa Seca. These values ranged from 800-950

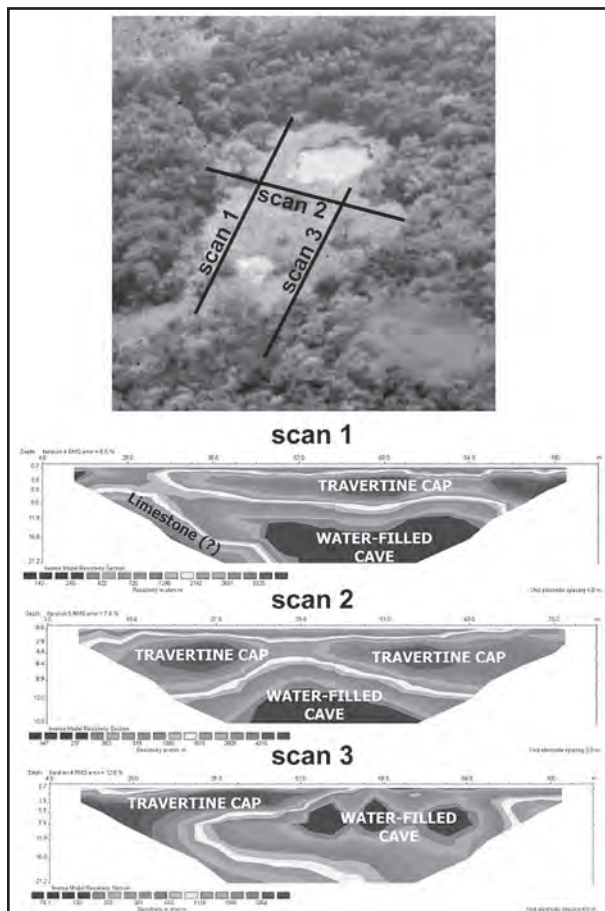

Figure 2: ERI surveys conducted at the cenote La Pilita were conducted in 2003 to test the applicability of the geophysical method to image this karst setting. Direct access to the water-filled cave in this cenote verified that the ERI data represented actual features that are hypothesized in other fully capped cenotes.

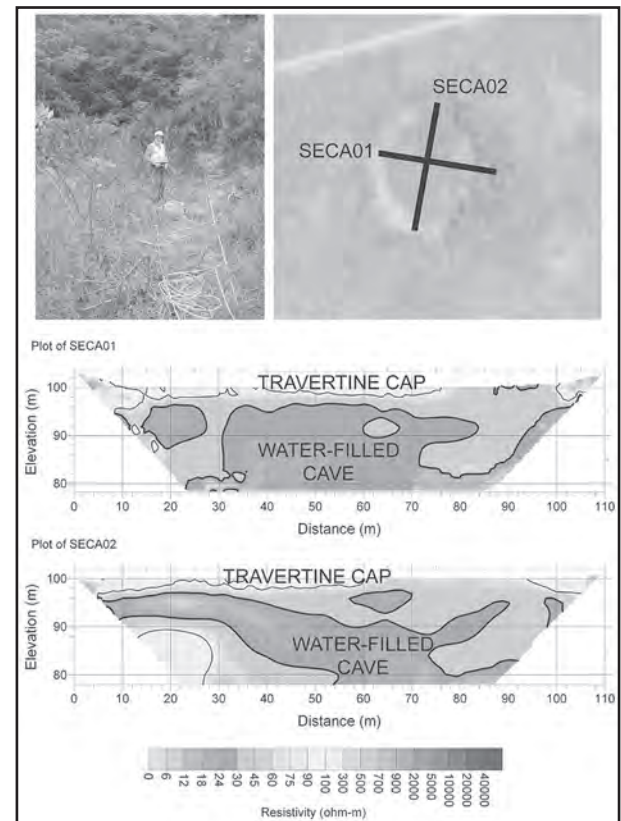

Figure 3: Upper left photo shows the setting electrodes in Posa Seca, and the upper right zoomed-in aerial view shows the perpendicular geometry of the two transects surveys at this site. ERI processed images shown below of these two transects show a clear electrical distinction between the thin travertine cap on the surface and an apparent water-filled cave underneath.

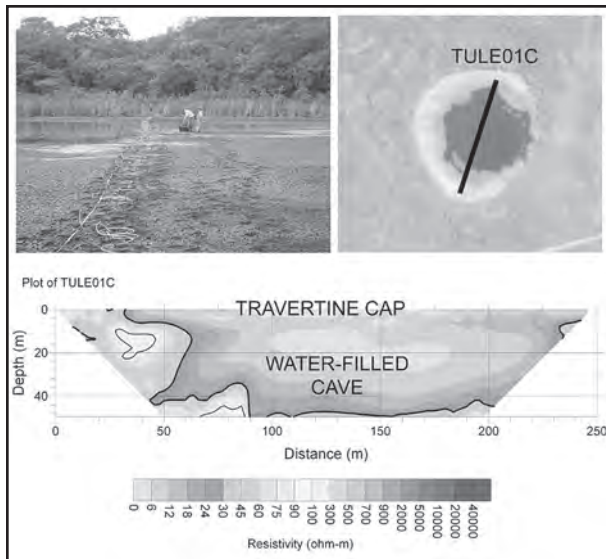

Figure 4: The upper left photograph on the cap of Tule and the ERI instrumentation. . The upper right aerial photo shows the ERI transect location. Note that water is present (about 1 meter deep) at the time of this photograph. Water levels were lower because of period of little rain at the time it was geophysically imaged, but the floor was wet and saturated. The lower image shows results from the survey. Electrodes were spaced at 5-meter intervals to span the 250 meter cenote, and the thin travertine cap is faintly resolved in this dataset. It is possible that a lower floor of the water-filled cave could be present, although the data in this spatial range are not optimal for geologic interpretation.

S/cm, thus a value of approximately 10 Ohm/m correlates to that of local water directly.

4. Results

The results of the ERI surveys demonstrate that for all four travertine locations, the ERI data presented resistivity values equivalent to the measured fluid resistivity of the fluids in the open cenotes with anoxic water. Preliminary surveys conducted at La Pilita were used to determine if electrical resistivity data could differentiate between the rock of the travertine cap and water-filled caves (Fig. 2). These initial data verified the method in this setting as zones filled with water are accessible by SCUBA diving and have been mapped in detail using sonar (GARY et al, 2008). Next, the closed doline of Poza Seca was imaged in two perpendicular surveys (Fig. 3). The ERI data show clear resistivity zones, and strongly resemble the hypothesized morphology of a capped cenote presented by GARY and SHARP (2006). An additional ERI survey of a capped cenote at Tule yielded similar results (Fig. 4), thus reinforcing the probability that these morphologies exist. The low resistivity of the high TDS fluids in the shallow lake combined with the higher electrode spacing limited the ability to resolve the cap across

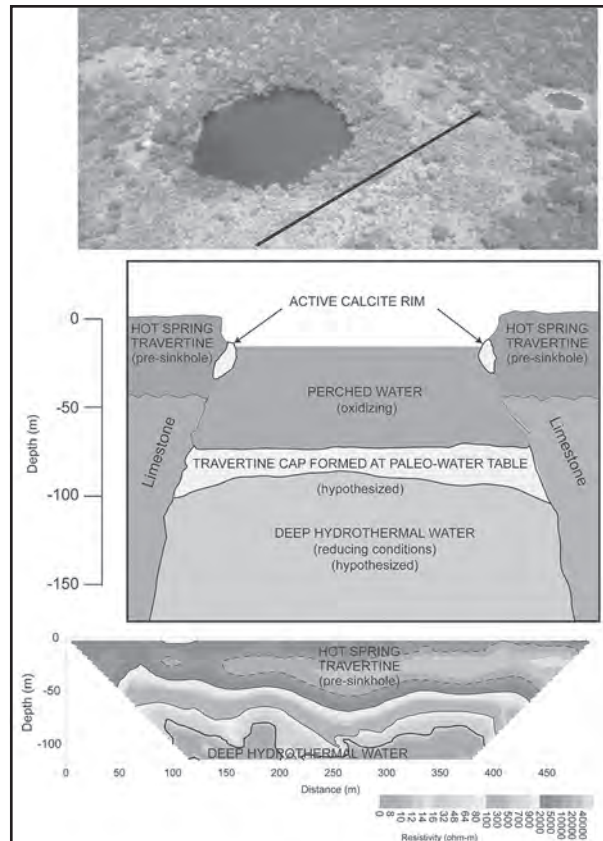

Figure 5: Top photo shows the cenotes Verde (left), La Pilita, (right), and a portion the location of the ERI transect line conducted near Verde. This photo shows the radially inward travertine growth at La Pilita. The middle image graphically displays the hypothesis that a paleo-water table once existed below the present day water table, allowing for a travertine cap to form. Subsequent rise in regional water levels creates a perched water body above this flooded cap. ERI data from the Verde transect (bottom image) shows evidence of the deep hydrothermal water hypothesized in the middle diagram.

the entire lake, but the cap is evident near the edges of the lake. A final survey conducted immediately south of Verde provides evidence that a deeper, isolated water-filled void may exist below the floor of this cenote with hydrothermal water similar to that in the deep cenotes of Sistema Zacatón (Fig. 5).

5. Conclusions

The karst area of Sistema Zacatón contains unique features defined as “travertine capped sinkholes.” These geologic phenomena occur when phreatic sinkholes open to the surface and allow degassing of CO₂ to cause precipitation of travertine at the water table. As the travertine accretes inward from the original sinkhole walls, it forms a thin cap of calcium carbonate that may extend over the entire sinkhole, sealing off the water below from the surface.

ERI was applied to successfully test this hypothesis. High values of electrical resistivity ($> 5000 \Omega\text{-m}$) are modeled relative to the high density calcite caprock of the study area, which has very low porosity except for karst voids. Mid-range resistivity values ($60 - 2000 \Omega\text{-m}$) relate to porous travertine caps, with higher levels of intra-granular porosity. Low levels of resistivity ($\sim 10 \Omega\text{-m}$) coincide directly with measured values of water, and are modeled accordingly. In the case of the cenote La Pilita, this process has either halted, or has not progressed to completion as an open hole from the deep water to the surface remains. Where the travertine cap completely occludes the deep groundwater, it creates a hydrogeologic barrier to water flow and can partition separate types of karst water as in the case of Tule and Verde. These hydrothermal underwater caves may host unique habitats containing a rich diversity of microorganisms. Should these settings be the tops of sealed phreatic tubes, they provide a setting where oxygen and light could have been added to the system for some period and then the system 'resealed' to allow the ecosystem to continue as a hydrothermal anoxic setting with no light or surface nutrient input.

6. References

- CAMACHO A.F. (1993), Compilation *Geologica de la Vertiente del Golfo de Mexico, Area 1*. Comision Federal de Electricidad, Subdireccion Tecnica, Gerencia de Estudios de Ingenieria Civil, Subgerencia de Estudios Geologicos, Departamento de Geologia. G-43, pp 123–130.
- DUBLYANSKY, Y.V. (2000), Hydrothermal speleogenesis – Its settings and peculiar features, *Speleogenesis Evolution of Karst Aquifers*, A. Klimchouk, D. Ford, A. Palmer, and W. Dreybrodt (Eds.), National Speleological Society, Huntsville, Ala. p. 292-297.
- GARY, M.O., N. FAIRFIELD, W.C. STONE, D. WETTERGREEN, G. KANTOR, J.M. SHARP Jr (2008) 3-D mapping and characterization of Sistema Zacatón from DEPTHX (Deep Phreatic Thermal Explorer), *Proceedings of the 11th Multidisciplinary Conference on Sinkholes and the Engineering and Environmental Impacts of Karst*, American Society of Civil Engineers Geotechnical Special Publication no. 183, pp 202–212.
- GARY M.O. and J.M. SHARP, (2006), Volcanogenic Karstification of Sistema Zacatón. in *Perspectives on Karst Geomorphology, Hydrology, and Geochemistry: A Tribute volume to Derek C. Ford and William B. White*, R.S. Harmon and C.M. Wicks (Eds.) Geological Society of America Special Paper 404, pp 79–89.
- GARY, M.O., T. HALIHAN, J.M. SHARP, S. MOURI, J. THORSTAD (2006) Electrical resistivity imaging of travertine capped sinkholes: Deep lakes with lids. *Geological Society of America, Abstracts with Program*, **39**, no.3, p 28.
- GOLDHAMMER, R.K. (1999) *Mesozoic sequence stratigraphy and paleogeographic evolution of Northeast Mexico*, Geological Society of America, Special Paper 340, pp 3–14.
- HALIHAN, T., S. PAXTON, I. GRAHAM, T. FENSTEMAKER, M. RILEY, (2005) Post-remediation evaluation of a LNAPL site using electrical resistivity imaging. *Journal of Environmental Monitoring* **7**, 283–287.
- RAMIREZ FERNANDEZ, J.A., F. VELASCO TAPIA, F. VIERA DECIDA, J.M. VASCONCELOS FERNANDEZ, M.O. GARY, (2007) Tertiary interplate mafic magmatism in the Eastern Mexican alkaline province : Villa Aldama volcanic complex, *Geological Society of America, Abstracts with Program*, **39**, no. 3, p 390.
- ROTH, M.J.S., J.R. MACKEY, C. MACKEY, J.E. NYQUIST, 2002, A case study of the reliability of multielectrode earth resistivity testing for geotechnical investigations in karst terrains, *Engineering Geology* **65**, pp 225–232.
- SUMANOVAC, F., M. WEISSER, 2001, Evaluation of resistivity and seismic methods for hydrogeological mapping in karst terrains, *Applied Geophysics* **47**, pp 13–28.
- VOUILLAMOZ, J.M., A. LEGCHENKO, Y. ALBOUY, M. BAKALOWICZ, J.M. BALTASSAT, W. ALFARES, Localization of saturated karst aquifer with magnetic resonance sounding and resistivity imagery, 2003, *Ground Water* **41**, no. 5, pp 578–586.
- ZHOU, W, B.F. BECK, A.L. ADAMS, 2002, Effective electrode array in mapping karst hazards in electrical resistivity tomography, *Environmental Geology* **42**, pp 922–928.

CHARACTERIZING SPRING DRAINAGE AREAS USING MODFLOW-DCM, A CONDUIT/DIFFUSE FLOW MODELING TOOL

RONALD GREEN, SCOTT PAINTER, JAMES WINTERLE
Geosciences and Engineering Division, Southwest Research Institute

Abstract

Delineation of spring drainage areas can be evaluated using tracer tests and water balance assessments. Each method has limitations. Tracer tests require an appropriate discharge point (or points) that can be monitored for breakthrough. Water balance assessment of spring drainage area requires that recharge and discharge rates are accurate, an evaluation that can be challenging when surficial sediments are significant, the epikarst terrain is complex, or if spring discharge cannot be reasonably measured.

MODFLOW-DCM, a variant of standard MODFLOW, has been used to simulate fast conduit and slow diffuse groundwater flow through karst aquifer systems. This modeling tool offers an alternative to assessing which relationships between spring drainage area size and recharge rates are realistic, particularly when discharge rates are not well measured or constrained.

Due to the complexity of karst aquifers relative to porous media aquifers, more information is required to model a karst domain relative to a comparable porous media domain. Information required by MODFLOW-DCM includes that information necessary to define the conduit network in addition to information on the diffuse component to the flow regime. Although there is added uncertainty with the additional degrees of freedom when modeling both the conduit and diffuse components to a karst flow regime, MODFLOW-DCM provides an opportunity to evaluate candidate conceptual models of spring drainage area boundaries and recharge rates by realistically accounting for both fast conduit flow and slow diffuse flow in a karst aquifer.

MAPPING OF KARST SOLUTIONAL FEATURES USING REMOTE SENSOR TECHNOLOGY

JOSUA D. KENNEY¹, GREGORY C. WILLDEN¹, RONALD N. MCGINNIS², BEN A. ABBOTT¹,
RONALD T. GREEN²

¹ Automation and Data Systems Division, ² Geosciences and Engineering Division
Southwest Research Institute, 6220 Culebra Road, San Antonio, TX 78238-5166, USA

Prototype sensors have been developed to autonomously map pathway, flow velocity, and dimensions as they flow through karst conduits. The prototype sensors are equipped with sonar and magnetometer to measure conduit morphology and orientation. The sensors are developed to be approximately neutrally buoyant but have been equipped with a propulsion system to enable the sensors to negotiate around impediments in the flow channel and avoid stalling at the walls of the conduit or cave. Data collected during an excursion are downloaded from the sensor upon completion of the survey mission. An autonomous sensor was successfully used to characterize a segment in Honey Creek Cave, a wet cave in south-central Texas. Sonar proved to be effective in measuring the cave dimensions and the velocity of flow. A magnetometer was used to orient the pathway taken by the sensor. Together, these data provided a representative reproduction of the oriented morphology of the wet cave. A variation to the initial generation of sensors is being developed to be applicable to map and characterize karst solutional features in which data retrieval from the sensor at the conclusion of the excursion is not possible or likely. For this application, a tether is attached to the sensor to allow real-time data collection. Motivation for this version of sensor is to map karst voids intersected by a drillhole but which discharge to a spring is not anticipated.

1. Introduction

In spite of the large reliance on karst aquifers for water resources, assessment tools appropriate for characterizing karst aquifers are inadequate and inferior when compared with similar tools developed for porous media-type aquifers, such as sand and gravel or sandstone reservoirs. In particular, groundwater modeling tools developed for porous media-type aquifers cannot accommodate both the rapid flow of groundwater through conduits and the slow flow and storage of groundwater in the matrix of karst aquifers. Understanding the geometry of karst conduits has been a difficult task. In order to accurately construct groundwater models, researchers must know the full extent of these features. A tool such as the one described in this paper can bring researchers closer to that goal.

Conventional methods used to directly characterize karst conduits include tracer tests (Alexander and Quinlan, 1992), and mapping by cave divers (Lauritzen, et al., 1985). Dye tracer studies, while useful for determining flow velocities in a system, do not accurately characterize the size and complexity of karst conduits. Mapping karst conduits through the use of cave divers is both costly and dangerous. In addition, cave mapping is limited to: (i) conduits large enough for divers to access, (ii) conduits with flow velocities low enough to be safely navigated by a diver, and (iii)

reasonable depths and distances. Sensors do not have these limitations.

Attempts to infer conduit locations using geologic features such as fracture lineaments and sinkholes have not proved entirely useful due to the fact that surface features do not always reflect what is underground. Therefore, a need exists to develop new tools to characterize conduits to improve the chance of success when employing karst aquifer flow modeling tools. The report by Kenny et al. (2008) describes the initial development by Southwest Research Institute* of a neutrally buoyant sensor designed to map and record flow velocities as they drift through a karst conduit.

2. Approach

The objective was to develop and demonstrate an inexpensive, neutrally buoyant sensor (hereafter referred to as NBS) that can measure and record the morphology and flow characteristics while traversing a karst conduit between an accessible launch and recovery site. The sensors are instrumented to record flow velocity, path traveled, and conduit dimensions as they flow through the conduits. Data are extracted from the sensor manually; therefore, the sensors must be retrieved at some recovery point.

The prototype NBS's were tested under various laboratory

and field settings to demonstrate and assess their capabilities. Field testing was performed at the Spring Creek Cave and Honey Creek Cave near San Antonio, Texas. Sensor sizes tested were 22 cm (i.e., small soccer ball size) in diameter, although they could be made much smaller.

The NBS's were assembled using commercially available components such as ultrasound sensors and dual-axis magnetometers and accelerometers. A general-purpose wireless sensor node with onboard processor and memory unit coordinated the overall operation of the data collection

components. The magnetometer provided the ability to gauge the orientation relative to magnetic north, and the accelerometer enabled the determination of motion dynamics (furnishing a form of inertial navigation) as the NBS travels through conduits. Ultrasonic transducers characterized the conduit geometry and, ultimately, velocity. Six pairs of ultrasonic transducers were positioned on each axis around the circular NBS vessel to emit sonar "pings" outwards to the conduit walls (Fig. 1). Each pair consisted of a transmitter, which sent out ultrasound pulses normal to the sensor node, and a receiver, which recorded the reflected ultrasound pulse. Accurate distances to the surrounding conduit features are determined using the time of arrival of the reflected pulses. The reflected pulses were calibrated based on the density of water and air. Sonar ranging gives a representative characterization of the conduit geometry. The rate of displacement of distinctive wall features is used in velocity calculations. Post-processing of the data from all components enables the calculation of real-time velocity of the NBS as it travels along the conduit path as well as calculation of the shape and size of the conduit. The orientation (magnetometer) data are used in combination with the sonar readings to detect features, derive velocity, and to ultimately unravel the data into a chain of vectors corresponding to the path taken, velocity profile, and measured conduit shape. Similarly, the floating

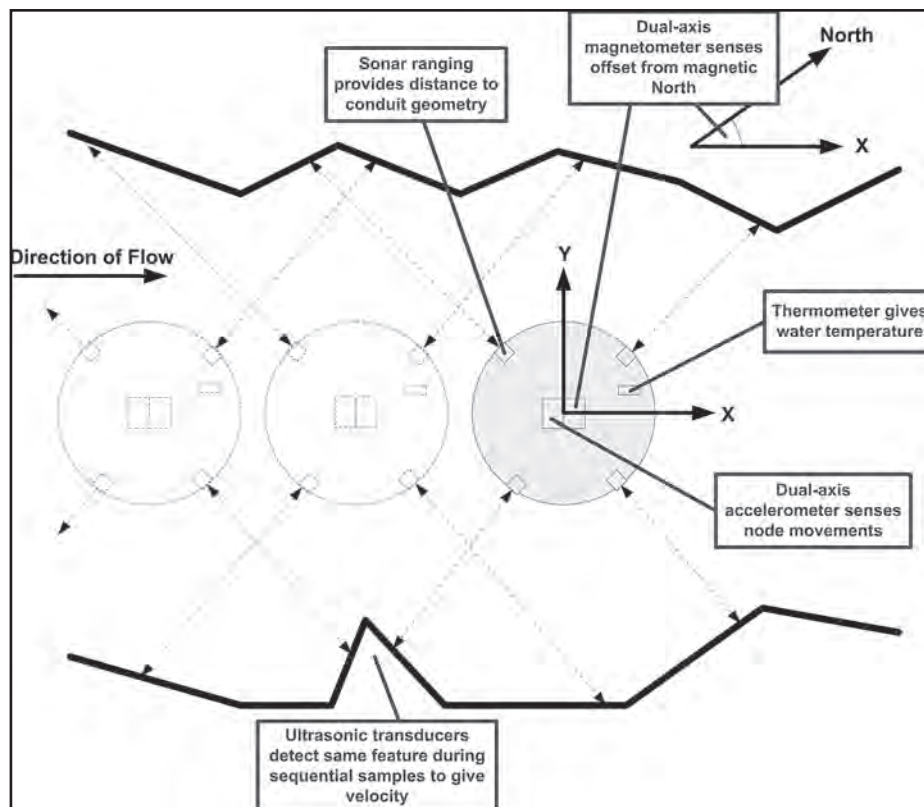

Figure 1: Neutrally buoyant sensor – Conceptual operation (plan view).

sonar coordinates are rectified to Cartesian position and distributed to the respective vector segment. Accelerometers are used to detect if any periods of rapid movement occur since these could adversely affect the triangulation used in mapping. The conceptual operation of the NBS is illustrated in Figure 1. The prototype circuit assembly with enclosure is shown in Figure 2.

Initial prototype deployment showed that spherically shaped vehicles tended to drift out of the main flow channel

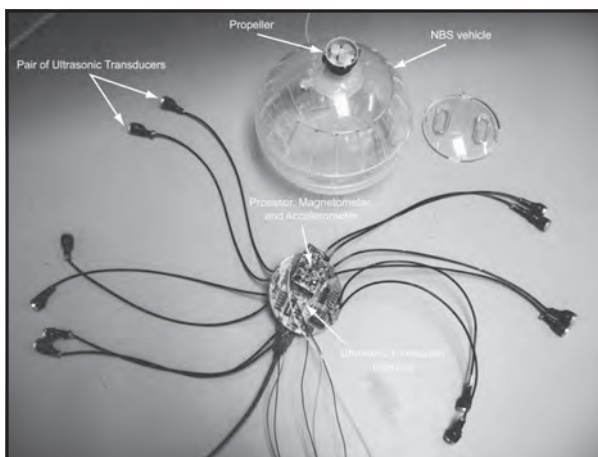

Figure 2: Prototype sensor node circuit assembly and enclosure.

and become trapped at the cave wall. This is attributed to forces associated with conventional velocity gradients in conduit flow. In a subsequent deployment, three sizes of sensor vehicles (i.e., balls) were evaluated to determine what size and shape would minimize sensor rotation. Their shapes were modified by adding a fin to prevent them from stalling at the cave walls. Attachment of the fin reduced the rotation and impeded the tendency of the sensors to rotate out of the flow field. It was also determined that the NBS's need to be weighted such that they remain upright to maintain the fins at the most effective horizontal orientation. In addition, having the NBS oriented in the upright position allows for simpler data processing and eliminates likely uncertainties.

Other challenges addressed in the design were achieving static neutral buoyancy and navigating features in conduits. Initial deployments resulted in the balls either floating to the surface or sinking to the floor of the cave. Most of the balls that floated at the surface became trapped by cave features (i.e., shelves, stalactites). As a result, the sensor assembly was modified to be dynamically buoyant by attaching a small motorized propeller to the outside bottom of the sensor shell. The propeller was programmed to engage at preset time intervals for driving the sensor vertically down (to escape ceiling protrusions) and driving the sensor vertically up (to overcome any eventuality of the sensor becoming embedded in mud or silt on the cave floor) interleaved with "off" time periods during which the propeller was not engaged. This was not true depth control; rather, in this case, the sensor was set to float at slightly positive buoyancy and the propeller simply pulled it down for the short periods.

NBS deployment on July 3, 2008, resulted in a transport trajectory that was sufficiently long and uninterrupted to allow collection of ultrasound, magnetometer, and accelerometer data of a 20 m-long stretch of Honey Creek Cave. The detailed process for data reduction is outlined in the report by Kenney et al. (2008). As expected, accelerometer data provided by the low-cost devices utilized had proven insufficiently sensitive to allow for an "inertial navigation" type of analysis. For this reason, we focused on geometry-based navigation utilizing the compass and sonar readings. Cross-correlated sonar data samples were used to determine NBS velocity along the conduit flow path, and individual samples were used to estimate conduit geometry (i.e., width, height, shape). Magnetometer data were reduced by converting the X-axis and Y-axis magnetometer readings to compass bearings at each time increment. Using these compass headings as well as the previous velocities that were calculated for each data sample in the sonar data, the X-Y path taken by the sensor node was determined. Obviously,

fast water and a spinning sensor could cause this method to fail; but the tail and the slow speeds along with a verification that the sensor did not spin throughout conduit traversal (based on magnetometer readings) allows the processing to assume the sensor generally follows a path parallel to the conduit. Local distances to the conduit walls were applied at each vehicle position to obtain a three-dimensional conduit map rendered using MATLAB's plotting functions. (Fig. 3).

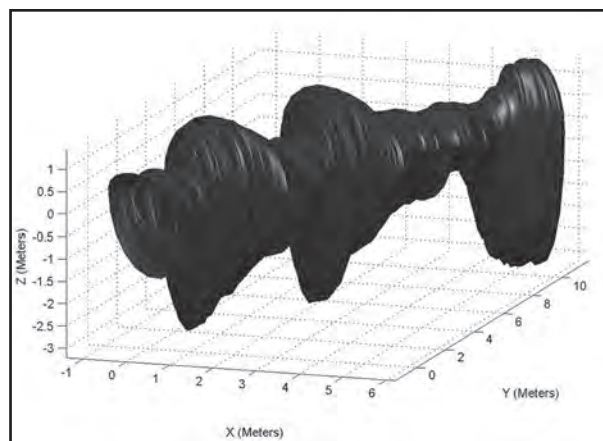

Figure 3: Final rendering of cave passage using sonar and magnetometer data collected during the July 3, 2008, prototype sensor deployment.

3. Future Enhancement

Based on observations from the initial design and deployment of the NBS, along with unique customer requirements, the NBS design can be refined to provide additional features. The microprocessor-based design allows custom applications to be realized and includes hardware to enable additional characterization of and access to the deployed environment.

Given the apparent success of the instrumentation, a future generation of sensor could be miniaturized with a size reduction by a factor of 5 to 10 (i.e., 2 to 5 cm diameter). Additional non-recurring engineering to the design would allow this size at very low per-unit production costs. The prototype used standard through-hole electronic components and was optimized for hand-assembly. Much smaller surface-mount electronic components could be utilized along with compacted conductor traces and multi-layer boards. In addition, standard off-the-shelf reference design packages were used to provide the processor and sensor interface. Integrating the individual processor chips and individual sensors used in these reference design packages into the custom NBS circuit would reduce cost by a factor of 10 and further reduce size. These modifications to the NBS result in a design that current printed circuit

board fabrication and assembly companies could produce in mass quantity at a very low unit cost (estimated at less than \$100 initially and perhaps an order of magnitude further depending on the quantity produced). The design also allows flexibility with multiple on-board analog-to-digital converter inputs to allow additional sensors to be integrated into the NBS circuit to collect additional environmental data such as gas composition and water chemistry.

The prototype NBS used a simple motor control scheme, allowing programmable periods of “diving,” “surfacing,” and “waiting” to help the sensor get free from some “traps.” More sophisticated feedback control algorithms could be employed, utilizing top- and bottom-mounted sonar to detect distances and provide input to the operation of the motor. Furthermore, motors and feedback sensors operating in additional axes would allow further degrees of precise movement. Alternative mechanisms for depth control (i.e., air-compressing pistons, ballasts, etc.) could be utilized to increase energy efficiency, increase movement precision, and reduce vehicle size.

A variation to the initial generation of sensors is being developed to be applicable to map and characterize karst solutional features in which data retrieval from the sensor at the conclusion of the excursion is not possible or likely. For this application, a tether is attached to the sensor to allow real-time data collection. Motivation for this version of sensor is to map karst voids intersected by a drillhole, but which discharge to a spring is not anticipated. The tether is a coaxial cable for transmitting samples of data to a surface processing computer. The anticipated operation would allow the sensor to be slowly lowered via drillhole into a void and, using ultrasonic ranging, compass readings, and known length of the cable, completely characterize the x, y, and z dimensions of the cavity. The NBS can be lowered further to intersect flowing water and collect a limited “path” of a conduit data. This allows real-time data acquisition and retrieval of the NBS. (Fig. 4).

Furthermore, the “tethered” NBS can be used in conjunction with traditional “floating” NBS units for the real-time mapping of even longer conduits where NBS units are unable to be collected for post-processing. This approach would use a single tethered NBS as a base station to send data to the surface. Mobile NBS units would be subsequently released into the conduit flow and would send data back to the tethered NBS via sound pulses modulated for communication. Each NBS would be outfitted for two-way ultrasonic communication, allowing them to continuously relay data back to the tethered NBS in a

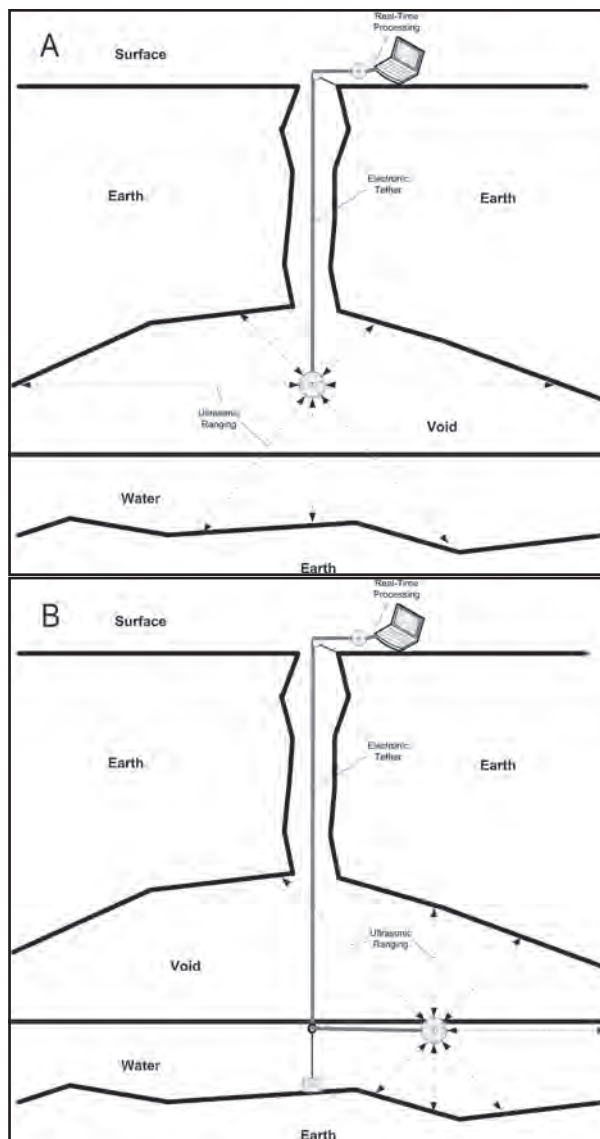

Figure 4-A,B. NBS data collection approach via an electronic tether.

“chain” limited in length only by the number of sensors and communication bandwidth (Fig. 5).

4. Conclusions

Prototype NBS's were developed to autonomously map the pathway, flow velocity, and dimensions of a karst conduit. The integrated analysis of sonar and magnetometer data collected in a field setting suggests that this approach successfully characterized a segment of a partially saturated karst conduit (i.e., Honey Creek Cave). Sonar data proved to be effective in determining the cave dimensions and the velocity of flow. The magnetometer data were used to orient the pathway taken by the sensor. Together, these data provided a representative reproduction of the oriented morphology of a wet cave.

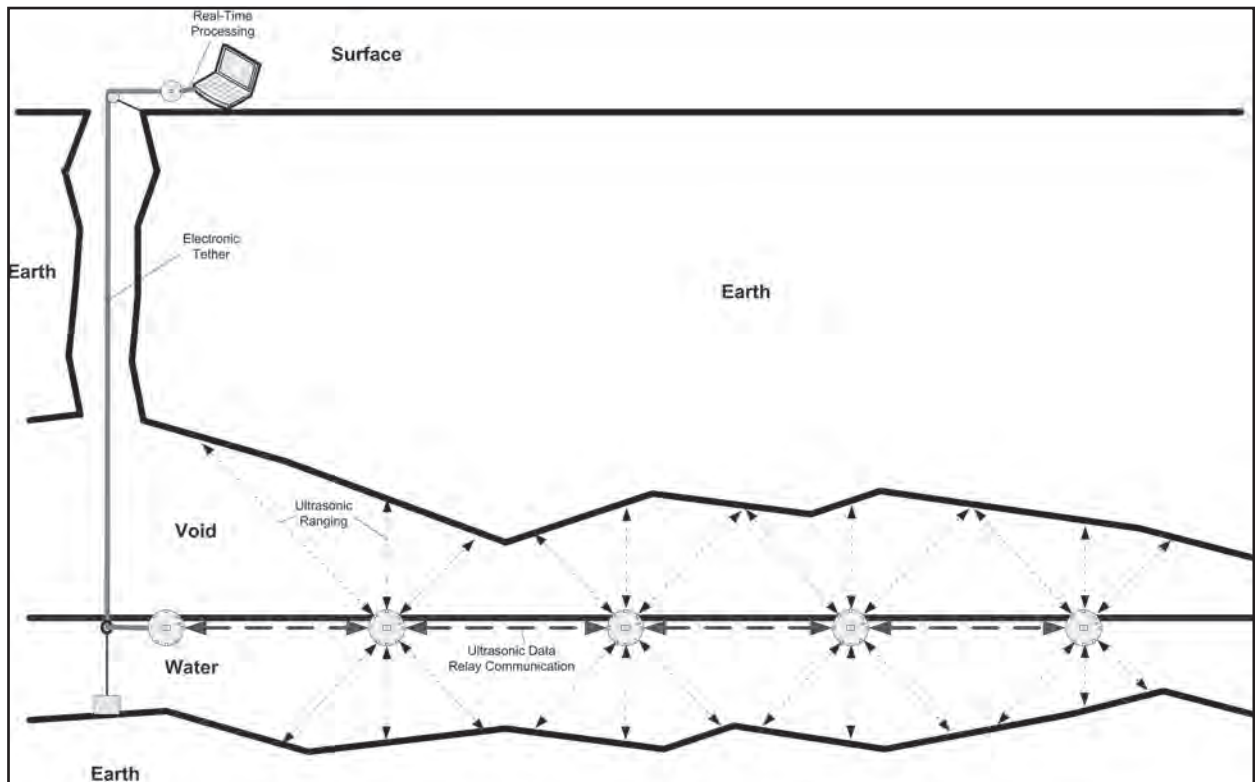

Figure 5. NBS data collection approach via an electronic tethered base station and multiple mobile units.

Additional refinement of the sensors would be beneficial to enable the sensors to map and characterize conduits in a karst aquifer. Deployment success could lead to immediate size reduction of the NBS and addition of different sensor technologies. Also, the prototype propulsion system could be replaced with a more sophisticated (i.e., intelligent) buoyancy system that would only be activated when needed (i.e., during prolonged periods of immobility). Based on future applications and environments, the sensor and overall data collection approach could also be modified to allow real-time data collection via a tether and when sensor vehicles are unlikely to “daylight” at a spring discharge.

References

- KENNEY, J.D., G.C. WILLDEN, R.N. MCGINNIS, B.A. ABBOTT, and R.T. GREEN (2008) Development of neutrally buoyant sensors for mapping conduits in karst aquifers. *Proceedings of the 11th Multidisciplinary Conference on Sinkholes and the Engineering and Environmental Impacts of Karst*.
- ALEXANDER, E.C. Jr, and J.F. QUINLAN (1992) Practical tracing of ground water, with emphasis on karst terrains. *Geological Society of America, Boulder, Colorado 2*, 195 & 133.
- FORD, D.C., and P.W. WILLIAMS (1993) *Karst Geomorphology and Hydrology*. Chapman and Hall, New York, NY, 601 pp.
- LAURITZEN, S-E., J. ABBOTT, R. ARNESSEN, G. CROSSLEY, D. GREPPERUD, A. IVE, and S. JOHNSON (1985) Morphology and hydraulics of an active phreatic conduit. *Cave Science 12*, 139–146.

THE DISTRIBUTION RULE OF PALEO-KARST COLLAPSE PILLARS IN NORTHERN CHINA AND THEIR NEW EXPLORATION METHODS

HE KEQIANG¹, LU YAORU²

¹*Qingdao Technological University, Qingdao, Shandong Prov. 266033, P.R. China*

²*Tongji University, Shanghai, 200439, P.R.. China*

Paleo-karst collapse pillar (PKCP) is a peculiar geologic phenomenon caused by the paleo-karst subsidence which occurred in carbonate rock distribution areas. They are widespread and have great damage in north China. According to statistics, there are a total of 39 sites of paleo-karst collapse pillars in northern China, as well as 3650 paleo-karst collapse pillars.

In northern China, PKCPs occur mainly in Shanxi, Hebei, Henan, Shandong, Shaanxi, Jiangsu and Anhui Provinces, located in the Shanxi Plateau, the eastern and southeastern piedmonts of the Taihang Mountains, the southern piedmont of the Yanshan Mountains, and the borderland of Shandong massif. According to statistical data on north China, Karst collapse pillars in Northern China apparently have three south-north trends in terms of distribution: (1) a zone along the banks of the Fenhe River; (2) western piedmont of the Taihang Mountains and; (3) eastern southeastern piedmonts of the Taihang Mountains.

On the basis of the distribution statistics and the mechanism of formation of PKCPs, a new exploration method of Integrated Prospecting of Successive Approximation is proposed in this paper. At present, there are ways to determine location of PKCPs with hydraulic conductivity. Every method has its advantages and disadvantages. It is hard to find the exact location of the hidden PKCPs with hydraulic conductivity unless all the large and small scale methods mentioned above, are used. Only using integrated methods can we locate hidden PKCPs effectively. Integrated Prospecting of Successive Approximation consists of the following steps: (1) comprehensively research the geological and the hydrogeological conditions of known karst PKCPs, and (2) on this basis, determine the scale, type of feature and shape of the hidden karst PKCPs. Then with hydraulic conductivity measurements, estimate the direction of large scale features, combined with an estimate of the plan view of the cavern. The last step is to carry out the investigation by the means of three-dimensional seismic, electromagnetic, chemical prospecting, water discharging experiment, the analysis of the water quality and borehole prospecting. This should be done by narrowing the extent of possible abnormal areas following the order of ground investigations first, boreholes second; then integration of the data to estimate the whole area first, then, center second.

1. Introduction

Paleo-karst collapse pillar (PKCP) is a peculiar geological phenomenon caused by the paleo-karst subsidence which occurred in carbonate rock distribution areas (He et al. 2005). PKCPs are widespread in provinces or regions of Northern China, such as Shanxi, Hebei, Henan, Shandong, Shanxi, Northern Jiangsu and Northern Anhui (He et al. 2005). The existence of the geologic phenomenon reduces recoverable coal reserves by damaging coal seams and influences comprehensive mechanized coal mining, but what is more important is, it usually functions as a channel for outburst of water and gas, thus posing a great threat to safe production of mines.

Since Japanese Onuki Yoshio defined PKCP for the first

time in the 1940s (Onuki 1944), many scholars have carried out research on PKCP to different degrees. In the initial stage after the founding of the People's Republic of China, coal exploration was massively conducted countrywide, and PKCP research focused mainly on the description of discovered PKCP in respect of their morphological characteristics and derivative structures. From the 1960s to the mid-1970s, PKCP research progressed slowly, but some geophysical exploration methods (for example, the radio penetration method) began to find their way in the detection of PKCP. Dmian et al. (2005) explored the underground caves in the region of Ghor Al Haditha, Jordan, with the high-accuracy gravimetric method, who also obtained satisfactory results. From the late 1970s, the range of PKCP research was extended rapidly to include

the morphological characteristics, formation mechanisms and spatial distribution of PKCP, and a number of theories were formed, such as “theory of karst cave formation due to cyclic expansion”, “theory of formation under gravity action”; “theory of formation under gypseous salvation”; “theory of formation due to vacuum erosion” and “theory of hydrothermal origin” (Qian 1988; Shi et al. 1998; Kang 1992; Yuan 1994).

This paper provides a systematic study of the distribution regularities, morphological characteristics and formation conditions PKCP in Northern China, as well as their damages that may occur. This is very meaningful to the development and protection of karst water environment, safe mine production and full utilization of coal resources.

2. Distribution Regularity of PKCP in Northern China

In Northern China, PKCPs scatter mainly in Shanxi, Hebei, Henan, Shandong, Shaanxi, Jiangsu, and Anhui Provinces (Fig. 1), most of which centralize in the Shanxi Plateau, the eastern and southeastern piedmonts of the Taihang Mountains, the southern piedmont of the Yanshan Mountains, and the borderland of Shandong massif (Chen 1993).

According to statistics, there are a total of more than 3650 PKCPs scattered in 39 sites in Northern China, which includes 3356 PKCPs of 19 sites of PKCPs in

Shanxi Province, 214 PKCPs of 8 sites of PKCPs in Hebei Province, 34 PKCPs of 7 sites of PKCPs in Jiangsu Province and 45 PKCPs of 3 sites of PKCPs in Henan Province (He et al. 2005). The biggest densities of distribution of PKCPs occur in coalfields in such regions as Taiyuan, Yangquan, Fenxi and Huoxian County of Shanxi Province and Jingxing and Fengfeng of Hebei Province. In the mine area of Huoxian County, Shanxi Province, for example, 1405 PKCPs have been uncovered so far, with an average density of distribution of 34.7 PKCPs/km². In Shanxi Province, PKCPs along both banks of the Fenhe River from Lingshi to Huoxian Counties are peculiarly developed, and the maximum density of distribution is up to 72 PKCPs/km² (which occurs in the Nanxiazhuang Mine, Huoxian County), coming in first in the province. Another example is the Jingxing Mine of Hebei Province, where there are a total of 112 PKCPs scattering in its mine area of 132 km².

According to statistical data on north China, PKCPs apparently have three south–north regularities in terms of distribution.

(1) Zone along the banks of the Fenhe River

Paleo-karst collapse pillars developed along the Fenhe River, i.e., extending from Huoxian to Fenxi, Lingshi, Fenyang and finally to Xishan of Taiyuan. Coalfields in this zone contain PKCPs, particularly in Huoxi and Xishan coalfields where PKCPs developed in a peculiar way. In this zone, Cambrian and Ordovician limestone and coal, as well as Permian coal

measure stratum, outcrop massively; they received directly the supplies of paleo-atmospheric precipitation and paleo-groundwater of the Fenhe River, plus sound paleo-groundwater circulation conditions, so paleo-karst was well developed, thus producing numerous PKCPs. In Huoxi Coalfield, for example, the Middle Ordovician limestone at the floor is 500–600 m in overall thickness. As a result of the good condition of limestone with big thickness and the very sound paleo-groundwater circulation condition, the PKCPs in Huoxi Coalfield

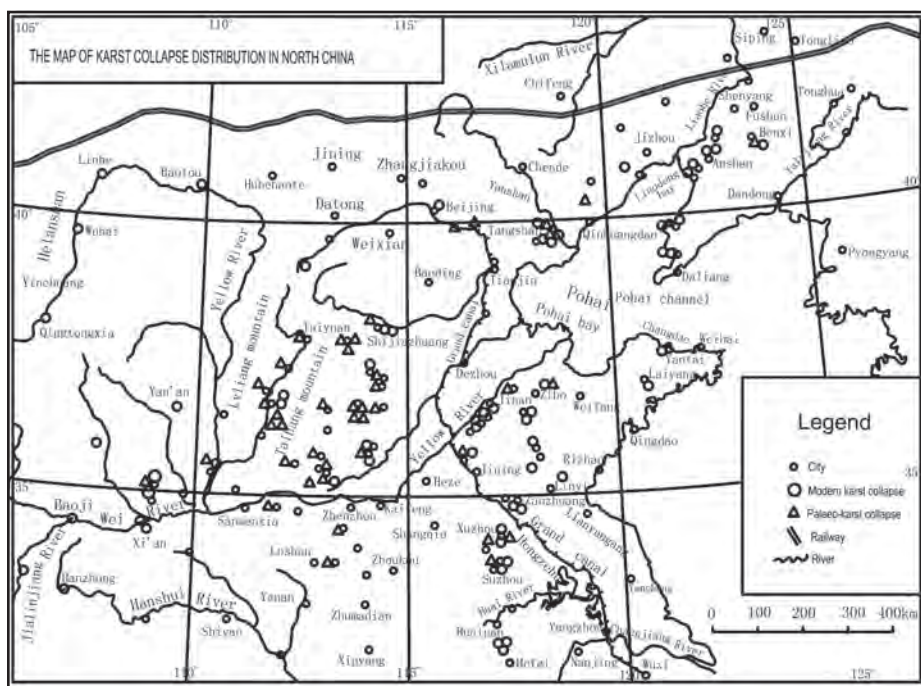

Figure1.:The Paleo-karst collapse pillar distribution in north China.

developed favorably (Li and Zhou 1989; Zhang and Chen 1996; Xu and Zhao 1990).

(2) Western piedmont of the Taihang Mountains

Paleo-karst collapse pillars occurred most in coalfields in the region ranging from Jincheng, Gaoping, Changye, Pingshun, Xiangyuan, Wuxiang to Xiyang, Pingding and Quanyang.

In this region, the Ordovician limestone was widespread and served as the floor of coal measure strata, so paleo-karst was quite developed. Judging from explorations and investigation, paleo-karst water in the region generally flowed towards the North China Plain. And in the process, surface water seeped massively into the deep-seated Ordovician limestone and then flowed east; most surface water flowed all the way to the eastern and southeastern piedmonts of the Taihang Mountains and then replenished the North China Plain. In such Ordovician limestone with extremely active paleo-groundwater circulation, substantive paleo-karst caves emerged and numerous PKCPs were thus created.

(3) Eastern and southeastern piedmonts of the Taihang Mountains

In the mine areas ranging from Jiaozuo, Hebi and Anyang of Henan Province to Cixian, Fengfeng and Jingxing of Hebei Province, PKCPs spread in an approximate south–north direction. In addition to direct supplies of atmospheric precipitation, this region also receives supplies of surface water and groundwater of the Shanxi Plateau. Thus karst water in the Ordovician limestone of the region is much abundant, with quite active water alteration, creating massive springs such as the Heilongdong Spring.

3. The Integrated Prospecting of Successive Approximation in Determining Hydraulic Conductivity of PKCPs

3.1 Means of integrated prospecting of successive approximation

At present, there are many ways to determine PKCPs with hydraulic conductivity. For example, geophysical prospecting, chemical prospecting, alley prospecting, borehole prospecting, hydrological geology analysis and so on. Every means has its advantages and disadvantages. It is hard to find the exact location of the hidden PKCPs with hydraulic conductivity unless by making use of all the means mentioned above, approximating from macrocosmic to microcosmic. Only so can we find out these hidden PKCPs effectively (Zhang and Peng 2004). The means of integrated prospecting of successive approximation is to comprehensively research the geological and the

hydrogeological conditions of projects on Orefield of known karst PKCPs' growing area, and on this basis, determine the scope, feature and shape that the hidden karst PKCPs with hydraulic conductivity might grow into from the angle of macroscopy, combining with the production plan of the mine, and at last carry out the investigation by the means of three-dimension seism, electromagnetism, chemical prospecting, water discharging experiment, the analysis of the water quality and the borehole prospecting. This should be done by shortening the scope of the abnormal areas following the order of ground first, well second; whole first, part second; periphery first, center second. Finding out the distribution scope of PKCPs by the means of integrated geophysical prospecting technology from the growing characters of the known karst PKCPs, we can summarize the general rules of the PKCPs' distribution by analyzing the project geological and the hydrological geology conditions of the growing area. Determine the possible growing areas of the unknown karst PKCPs in the whole mine by combining the area geology, stratum and the hydrological geology conditions. Because the hidden karst PKCPs with hydraulic conductivity may have a relative large developing area, it is hard to determine them directly. In order to narrow down the scope of target area, usually some means will be used first on the ground extensively, for example, three dimension seism prospecting technology or Po-210, Po-218. Thus, the abnormal area can be determined among possible growing areas, that is, suspected suspicious areas of PKCPs.

(1) Three-dimension seism prospecting technology

Three dimension seism prospecting technology is a relatively well-developed geophysical prospecting technology to survey the coal measures conformation. The theory is to transmit the seismic waves on the ground and receive the return waves through radioactive detector. By analyzing the parameter of the return waves from different geological interface by the computer, the geology entities, such as the faultage, magma rocks, and PKCPs in coal layers can be explained with advantages that it can prospect a large area with low cost and disadvantage that it is influenced by the earth's surface and terrain much.

(2) The methods of Po-210, Po-218

The methods of Po-210 and Po-218 are done by taking sample of the rock and earth on the earth's surface and measuring the data of the radioactive element Po. By analyzing and calculating the normal and abnormal value, the geological conformation can be ascertained. Then the horizontal position of abnormal area can be located almost. The disadvantage is that the precision is low and it

is influenced by the terrain. The advantage is that it is cheap, easy to operate, and little time is needed to analyze the data for relatively wider prospecting scope.

3.2 Finding out under-well PKCPs by the means of integrated prospecting

A few small abnormal areas can be determined among the suspected hidden karst PKCPs with hydraulic conductivity by the means mentioned above. However, its precision is relatively low and the scope of the abnormal area is still large. The diameter of the PKCPs is only dozens of meters long, a small target compared with the abnormal areas that are hundreds of meters wide. Meanwhile, error will happen between the ground prospected abnormal area and the location of PKCPs. Therefore, geophysical prospecting technology should be applied to find abnormal areas with high water-level in each water layer under well to further narrow down the scope of abnormal area, determining the exact location of PKCPs. At last, borehole should be used to find out whether the assumption is true or not.

(1). Ascertaining abnormal areas of high water level through comprehensive water level of under ground water

After finding out abnormal areas through ground object detection, first, bore under constructed wells as well as water outlet in abnormal areas, conducting hydrogeological experiment and analysis to seek for areas of relatively higher water level in regional water carrier. Using ground-objectives prospecting in abnormal areas with high water level can further narrow down its scope.

(2) Ascertaining abnormal areas of high water level through electromagnetic method

Physical prospecting method under well has strong capacity and high efficient with low cost, used often in detecting hidden PKCPs, among which audio transillumination and transitory electromagnetism are regular. Audio transillumination is a method that used in detecting water yield property of terrain comprehensively, enclosing the border of PKCPs with hydraulic posts. Transitory electromagnetism is a method to enclose PKCPs by detecting water yield property of earth layer. For example, in Fangezhuang; such method has been taken in three different level areas, enclosing the border line of 1# and 2# PKCPs.

3.3 Drilling to determine hidden PKCPs with hydraulic conductivity

As the last step of successive approximation prospecting, drilling has relatively small construction volume and low cost but narrower detecting scope, making this method

has to be taken under instructions of physical prospecting to enclose abnormal areas of PKCPs, validating ultimately, proving up a definite border line of PKCPs for reliable information while in actual work, direction needs to be taken when detecting PKCPs according to existing hydrographic, geological, physical and chemical prospecting data to predict if the post is anhydrous or with low water conductivity. Construction should be taken after definite detecting methods have been made. For those PKCPs with high water conductivity, drilling prospecting should be maximally avoided to keep accident away.

4. Conclusions

Through the analysis above, the conclusions can be made as follows:

(1) PKCP in North China, formed in a particular geological environment, is a unique vertical geological structure in North China's paleo-karst development regions, which can lead to severe geological environmental problems. Basic geological conditions and dynamic conditions for PKCPs formation include stratum structure, geologic structure, paleo-karst characteristic, dynamic condition of paleo-karstic groundwater and neotectonic movement;

(2) In North China, there are a total of 39 sites of PKCPs and 3650 PKCPs, which includes 3356 PKCPs of 19 sites of PKCPs in Shanxi Province, 214 PKCPs of 8 sites of PKCPs in Hebei Province, 34 PKCPs of 7 sites of PKCPs in Jiangsu Province and 45 PKCPs of 3 sites of PKCPs in Henan Province. These PKCPs scatter mainly in Shanxi, Hebei, Henan, Shandong, Shaanxi, Jiangsu and Anhui Provinces etc., most centralizing in the Shanxi Plateau, the eastern and southeastern piedmonts of the Taihang Mountains, the southern piedmont of the Yanshan Mountains, and the border-land of Shandong region. They obviously have three south-north regularities in geological distribution: along the banks of the Fenhe River, the western piedmont of the Taihang Mountains, and the eastern and southeastern piedmonts of the Taihang Mountains.

(3) The most serious damage of PKCPs to the geological environments is the water inrush hazard of mining pits. The other damages of PKCPs to geological resources and environment mainly include: (i) damage to coal resources, reflected mainly by resources damage caused by PKCPs themselves; (ii) waste of resources caused by barrier pillars reserved to prevent water-filled PKCPs; (iii) adverse impacts upon the stability of pounding of water reservoirs and dam foundations.

(4) Based on the basic geological features of paleo-karst collapse pillars in Northern China, this paper also introduces the new method of integrated prospecting of successive approximation to determine hydraulic conductivity of paleo-karst collapse pillars. The detecting results in determining PKCPs in Fangezhuang coal mine prove that the method of integrated prospecting of successive approximation is an accurate and effective technique in detecting the PKCPs.

References

- Chen S (1993) A discussion of the origin of karst collapse pillars in Fengfeng region of Hebei Province. *Carsol Sin* **12**, 233–243
- Dmien C, AK Najib, JH Musa (2005) Subsidence and sinkhole hazard assessment in Dead Sea area. *Jordan Pure Appl Geophys* **162**, 66–71
- He K, B Wang, R Du (2005) *Karst collapse in north China*. Geological Publishing Company, Beijing, pp 152–166
- Hu G, W Yang (1984) *Engineering geology*. Geological Publishing House, Beijing
- Kang Y (1992) A discussion of karst collapse formulation patterns. *Hydrogeol EngGeo* **119**(4), 32–33
- Li J, W Zhou (1989) Hydrogeologic environmental prediction of water inrush using North China mine collapse pillars as water-transmitting channel. *Carsol Sin* **8**(3), 192–198
- Onuki Y (1944) Report of collapse pillars in Jingting coalfield Hebei province. *Joint-stock company Investigation Bureau*. **9**(4), 42–56
- Qian X (1988) The formation of gypsum karst collapse pillars and hydrogeologic implications. *Carsol Sin* **7**(6), 344–346
- Shi J, D Lian, S Yang (1998) A discussion of karst collapse. *Geol Min Res North China Mag* **13**(3), 264–266
- Thomas MT (1995) Mechanics of upward propagation of cover-collapse sinkholes. *Eng Geol* **52**(1–2), 23–34
- Wang R (1982) A discussion of the formation of karst collapse pillars in North China. *Hydrogeol EngGeo*, 37–41
- Wu J, J Yan, B Xu (1998) Investigation into features and genesis of the karst collapse-columns of the Liuqiaofirst coalmine in Wanbei. *Jixian Mining Instate* **(4)**, 315–319
- Xiang Y (1993) The mechanics model on flooding process of collapse pillar. *Coal GeolExplor* **21**(5), 36–39
- Xu W, G Zhao (1990) A probe into formation mechanism and water inrush of karst collapse pillars within coalmines of North China. *Hydrogeol EngGeo* **16**(116), 41–43
- Yang W, Z Zhou, Z Li (2001) Analysis of the filling characteristics of karstic collapse pillars and its reactivation-induced water-conducting. *Carsol Sin* **20**(4), 279–283
- Yu Z (1990) The characteristic and prediction of collapse of palaeo-karst pillars. *Coal Geol Explor* **2**, 42–45
- Yuan D (1994) *Karstology of China*. Geological Publishing House, Beijing
- Zhang B, Z Chen (1996) The distribution regularity and hydrogeo-logic implications of karst collapse pillars in coalfields of North China. *J Fuxin Mining Inst (Nat Sci Edn)* **15**(3), 295–298
- Zhang L, L Peng (2004) Available approaches to find out hidden water flowing subsided columns-an integrated prospecting of successive approximation. *Coal Geol China* **16**(6), 55–57
- Zhang Y, Y Qu, G Liu, P Lu (2000) Some problems of karstic collapse pillars in North-China-type coal fields. *J Eng Geol* **8**(1), 35–39
- Zhou Z, W Yang (1999) The background of rocks mechanics of karst Collapse column in Shanxi. *China Coal Sol* **24**(4), 341–344

KARST INSTRUMENTATION TO STUDY SITE EFFECT EXAMPLES IN CHORANCHE CAVE (FRANCE) AND MADRE DE DIOS ARCHIPELAGO (CHILE)

L MOREL¹, STEPHANE JAILLET², ANNE SOPHIE PERROUX², JEAN-JACQUES DELANNOY², YVES PERRETTE², VINCENT LIGNIER³, EMMANUEL MALET², RICHARD MAIRE³, and ULTIMA PATAGONIA 2008⁴

¹ *Lab Ampère, Université de Lyon 1, 43 boulevard du 11 nov 1918, 69100 Villeurbanne France
laurent.morel@univ-lyon1.fr*

² *Laboratoire EDYTEM, Université de Savoie, CNRS, Campus scientifique, 73376 Le Bourget du Lac, France*

³ *CNRS, Laboratoire ADES, Maison des Suds, Esplanade des Antilles, 33607, Pessac cedex, France*

⁴ *Association Centre Terre, Pasquet, 33760 Escoussans (France)*

Using sediments deposits as paleo-environmental archives need a good understanding of their settling conditions and therefore a good understanding of their sedimentary environment. However, because karstic environment is generally complex and heterogeneous, this type of study remains quite difficult. This original project tends to characterize the different karstic site effects on water circulation and sedimentation. It takes into account different parameters which constraint the sedimentary environments such as geomorphologic and hydro geological context and karstic voids geometry. The investigations mainly focus on the sites of Choranche Cave (France) and Madre De Dios Archipelagos (Chile). These two sites have been equipped with several measure instruments in order to constrain the site effect on water circulation, sediment transfer and deposition. This article describes how these sites have been instrumented and the first results obtained on each of them.

1. Introduction.

To understand the site effect, it is advisable to also study, from instrumented sites, the features of the information transfer and the recorded signal in the active concretions and in drowned subterranean environments (detrital rhythmites). Multi-sensor physico-chemical analysis workstations (water flow, chemistry, etc.) are being or have already been installed in Choranche cave in the Vercors Mountains (French Alps) and in Madre de Dios archipelago (Patagonia, Chile). The recorded signals will then be subjected to a non-destructive multi-resolution analysis, both morphologically and geochemically by microscopy, portable X-ray analyzer, micro-XRF, and nuclear microprobe.

In this study some other sites are also instrumented because of the evolution of environmental specific conditions as climate, hydrodynamic functioning, human activities and local effects :

- residual underground glacier of Scarasson at 2000 m high (Southern Alps, Italy) related with global warming and subterranean disconnecting with external snow feeding ;
- Bois du Clos and Fuie Caves in low plateau of Charente

(West France) under influence of a large regional drowned aquifer ;

- Grand Antoine Sinkhole in Entre-Deux-Mers low plateau karst (Southwestern France) related with the erosion of the impervious cover, the climatic evolution since Middle Age (Little Ice Age) and the human impact (vineyards, quarry) ;
- Dadong Sinkhole in mountain karst of Hubei (China) with a 20 m thick rhythmite loam deposit controlled by monsoon climate, deforestation and fire since 12,000 years.

2. Choranche cave.

The Choranche cave is located in a deep gorge, under a 250 to 300 meter high limestone. This cave presents the following advantages: it contains a great variety of speleothems, two rivers and two lakes with detritic sediments. The cave has already been studied from geological and chemical points of view (Delannoy, 1997). Many instruments are already installed in the cave.

For the study, the instrumentation monitors the "Chevaline" river, with a sump and a lake (Figs. 1, 2, and 3). First of all, the hydrodynamics are studied, and then secondly, the transfer of the sediments between the sump

and the lake. To study the lake sediments, it is important to know how they are coming into the lake. The sump has an important role in the transition of these deposits.

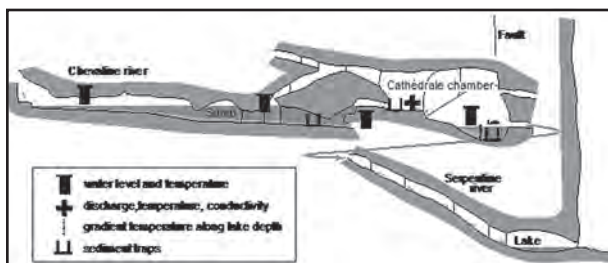

Figure 1: Instrumentation location in the cave.



Figure 2: Photograph of the river between sump and lake. Author S. Jaillet.

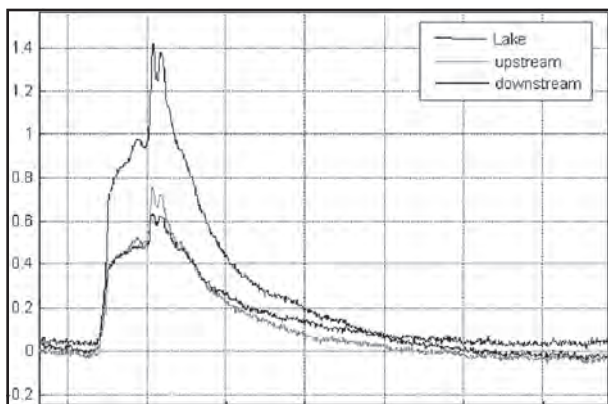

Figure 3: Water level in the lake, upstream and downstream sump during flooding.

In Choranche caves, in addition to the study of sedimentary filling up (Perroux, Desmet et al., 2004) (detrital accumulations in the siphon and the lake), one of the means used to monitor present sedimentation now is the establishment of sediment traps in the different key points of the study area of the cavity. To take into account the site effect, it is important to understand the sediment dynamics, the transit of detrital particles, to a better interpretation of

the signal recorded in the accumulation of these deposits.

In the specific case of the Choranche study area, one of the main questions is that of water-sediment interactions between the siphon located upstream of the lake and the lake, which is the main sediment trap (almost 7 m thickness). Indeed, the siphon could act as a “filter” temporary and / or partial of the detrital information transported to the lake. In this case, the filtering of the siphon could work up to a certain level of filling. A threshold effect could then intervene and allow a massive sediment discharge from the lake. In this functional case, detritic signal finally recorded in the lake would be a “contraction” of the initial hydro-sedimentary signal and exacerbate hydrological events. Thus, sedimentation finally studied in the lake does not refer at all the same type of information: instead of a continuous record of external fluctuations, the infilling emphasizes exceptional events in the hydro-sedimentary dynamics of the karst drainage network. Both types of data are interesting, but are very different, hence the importance of knowing the processes involved, and the specific site effects of this subterranean sector.

Therefore, sediment traps will permit us to trap detrital material that is currently circulating in the underground river. The analysis and comparison of this detrital material collected will provide some answers to this functioning question, which is essential for the interpretation of detrital records finally accumulated in the lake.

With the help of divers speleologists, three multi-traps were placed Choranche: 1 in the siphon, 1 in the intermediate basin, and 1 in the lake. Each consists of four types of tubes (vertical, in “T”, in conical “T”) to be compared with each other. Fixed on a slab that serves as ballast, the tubes can be sampled by diving, leaving the slab in place. Thus monitoring over the long term will not be affected by changes in the traps positioning. After 16 months on site, the first raising of these traps are already several interesting information on the hydro-sedimentary functioning of the karst area studied:

Different models of tubes were tested to detect any type of tube particularly effective. Thus, for each sediment trap, a quadruplet of tubes was installed. Each tube has the same diameter, and those with a horizontal part were obviously turned toward the river current. It follows from this experiment that the different types of tubes trap all material perfectly equivalent in granulometry, but in unequal amounts. This experiment has helped to keep

the tube models are most effective to continue this work (for example, the tallest tube was quickly eliminated) and multiply with relevance areas equipped with traps.

Between the siphon, the intermediate basin and the lake, the amount of sediment trapped is growing globally, as shown in Figure 4. These data confirm the fact that the lake is the main sediment trap, and that includes as much information in its sediment accumulation. Moreover, this vision upstream - downstream show that the traps upstream of the lake does not block a part of the sediment transport, at least not permanently. All material passing well to the lake. This information is important; it demonstrates and validates the information that resides in the detrital filling of the lake.

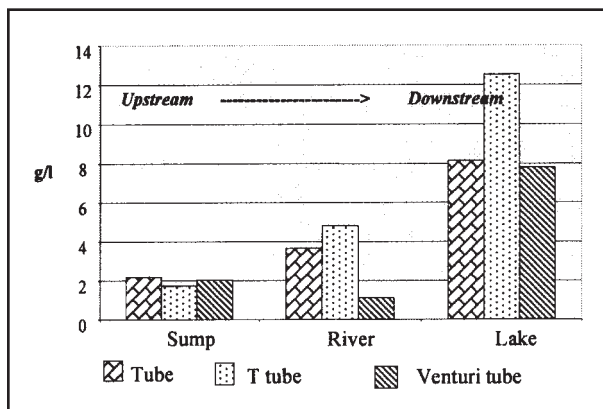

Figure 4: Sediment trapped in sump, in river and in lake with different models of trap.

Finally, particle size could be obtained on the material recovered in the traps. The information here is very interesting because it is possible to show that the sediment traps in the upstream of the lake, the siphon and the intermediate basin, have a sedimentary functioning very different. Figure 5 provides an overview unequivocal of the material trapped in the traps. The material trapped in the siphon is very homogeneous and of a granulometry corresponding to silts. As against the level of the intermediate basin, we find this silty granulometry, but it is accompanied by an important coarser fraction, to sand from multi-millimetric calcite slabs. These observations suggest that the siphon, at the moment, is rather the seat of a starting material as a deposit.

The study from sediment traps is an essential contribution to understanding the hydrosedimentary system that constrains the detrital filling in the Cathédrale Lake. This includes understanding the role of the siphon, which is a large size natural trap, located upstream of the lake. The detrital material recovered from the traps tend to favour the hypothesis that the siphon, to date, is not a important

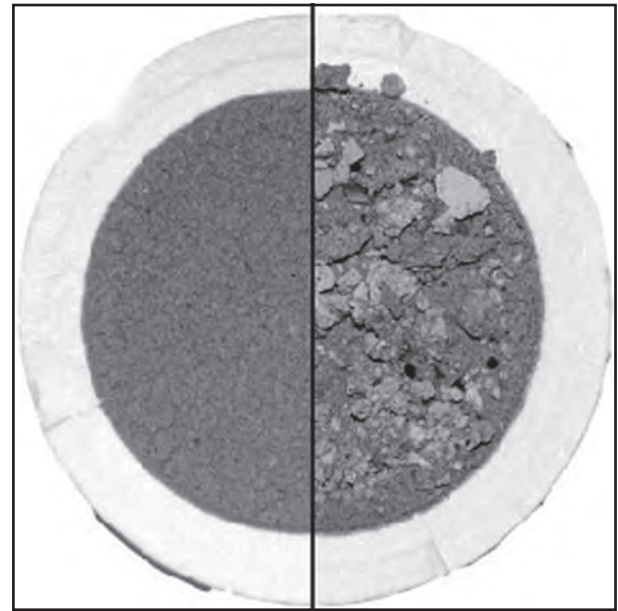

Figure 5: Material trapped in the traps, on the left sump (0,483g/l), on the right river (2,9g/l). Author A. Perroux.

sediment trap and does not stop a part of the detrital load, to the extent of affecting the quality of sediment recording in the lake. Instead, in light of the current hydrology, this siphon would be more likely in a drainage phase.

3 Madre de Dios: Chilean Patagonia.

3.1 Madre de Dios location and historic expedition.

The second place presented is located in Madre de Dios archipelago, at 50°30' S, on the Pacific front. The karst areas of Chilean Patagonia have long remained unexplored because of their remoteness, difficult access and very inhospitable cold, wet, windy climate. Annual rainfall is 7-8 m/yr⁻¹ and the average wind speed reaches 70 kph⁻¹ (Fig. 6). The first reconnaissance of the French association Centre-Terre was made in 1995 by a four-caver team aboard a tiny fishing boat and allowed a brief incursion on Diego de Almagro at 51° 30' South (Pernette et al., 2009). The aim was to verify the presence of karst and possible cave systems on some of the isolated islands. Four other expeditions took place in 1997, 2000, 2006 and 2008. The discovery of Kawésqar remains (burial sites) and paintings, unique shapes of rock like exokarst runnels, rock comets (wind-oriented solution features), the Whale Cave with many whale bones located between +6 and + 37 m high (Maire et al., 2009), and many other discoveries confirmed the archaeological and geomorphological potential. The absence of frost below 500m above sea level, the record rainfall and strong winds coming mainly from the ocean, form an exceptional karst (Maire et al., 2008). This unique region is named the

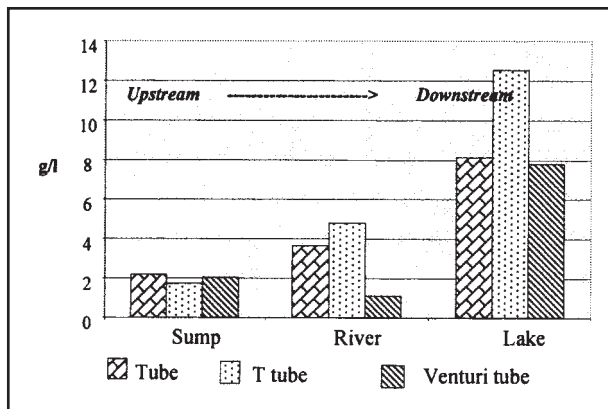

Figure 6: Rainfall and temperature in Madre de Dios in recent years 2004–2007.

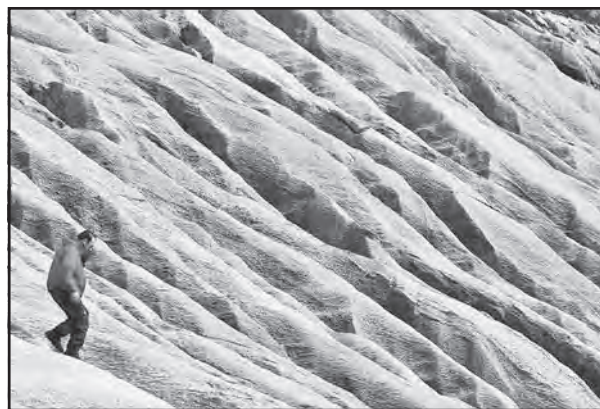

Figure 7: Exokarst runnel. Author S. Jaillet, Centre Terre.

“Marble Glaciers.”

Four sites are instrumented: (1) Hydrometeorology station of North Tarlton for exokarst runnels; (2) Mask Sinkhole (Guarello), underground river fed by three lakes at the contact sandstone-limestone; (3) Plein Cintre cave, a young karst spring situated on Soplador hillside; (4) Kawtcho Sinkhole located at the bottom of the valley, continuing on from the Soplador. It collects part of this valley’s water with an average flow of few hundred litres per second.

In sites 2, 3, and 4, the water level (function of water flow) and temperature are recorded during two years with a time step of 3 minutes. These sites present three different dynamics. The caves develop at sandstone limestone contact. The rainfall is very high and involves strong floods at a high rate. The results will provide knowledge about the rising time, number, and rate of floods .

3.2 Hydrometeorology station of North Tarlton for exokarst runnels study.

Exokarst runnels are a typical feature of Madre de Dios (Figs. 7, 8, 9). These drainage forms imitate hydrologic networks in miniature (Fig. 10). All the major forces of terrestrial karst erosion are there: fluvial erosion, meander formation, regressive erosion. With an annual rainfall of 8 m, the rate of surface dissolution is a record of 8 to 16 mm/century. Runnel floods have been observed at nearly every rainfall. The study will enable carbonate export to be quantified according to the season and weather conditions.

The hydrometeorological station records wind velocity and direction, air temperature and humidity, rainfall, atmospheric pressure at 30 second intervals. Three main runnels at the end of the catchment have also been instrumented (Figs. 11, 12). The discharge and temperature



Figure 8: Exokarst runnel. Author S. Jaillet, Centre Terre.

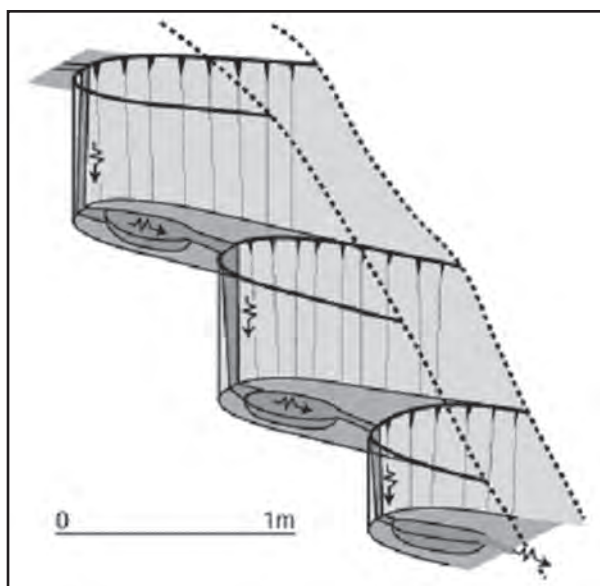

Figure 9: Original morphological regressive step erosion.

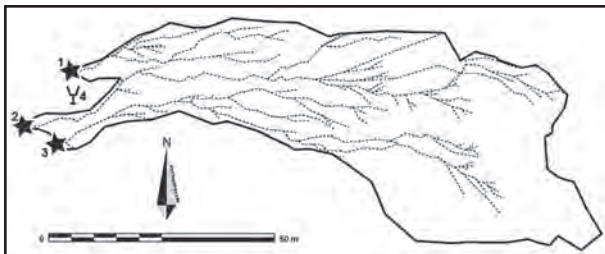

Figure 10: Hydrological catchments and runnel survey.

of these three runnels and conductivity of one of them have been recorded. Typical floods of row runnels data are presented in Figure 13.



Figure 11: Instrumented runnel.
Author L. Morel, Centre Terre.

4. Conclusions

Two instrumented sites are described and the initial results have been presented. This study is at its first stage and further results will be presented in future papers. The natural caves are exceptional black boxes. We have a duty to understand the messages written in concretions, deposits, and landforms, taking account of course site effects.



Figure 12: Meteorological station.
Author B. Fromento, Centre Terre.

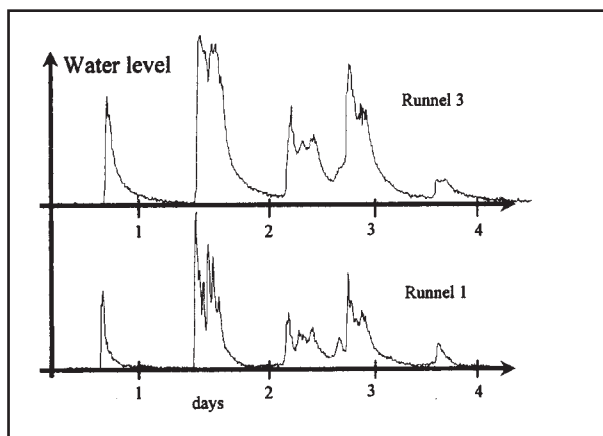

Figure 13: Exokarst runnel floods, February 2008.

References

J.F PERNETTE, B. TOURTE, R. MAIRE The Centre-Terre expeditions to Patagonian karst islands: a historic overview. *Publishing pending UIS 2009.*

- R. MAIRE, B. TOURTE, S. JAILLET et al. Geomorphic and archeological features of coastal caves in madre de dios archipelago (Patagonia, Chile). *Publishing pending UIS 2009*.
- A.S. PERROUX, M. DESMET, J.J. DELANNOY and Y. PERRETTE, (2004). - Endokarstic sedimentological processes in the alpine area: Attempt of Holocene palaeoenvironmental and paleohydrological reconstructions. - *Holocene climate in the Alps: Toward a common framework. 15-18 January 2004, Aix Les Bains (France)*.
- S. JAILLET, R. MAIRE, F. BREHIER et al Englacement, eustatisme et réajustement karstique dans l'archipel de Madre de Dios (Patagonie, Chile). *Karstologia 57, 1 semester 2008*.
- J.J. DELANNOY, Recherches géomorphologiques sur les massifs karstiques du Vercors et de la Transversale de Ronda. Les apports morphogéniques du karst. *Thèse d'Etat, Université J. Fourier, Grenoble, Publication Septentrion Editions, Villeneuve d'Ascq, 1997*.

CHARACTERIZATION OF KARST SOLUTIONAL FEATURES USING HIGH-RESOLUTION ELECTRICAL RESISTIVITY SURVEYS

JAMES PRIKRYL, RONALD MCGINNIS, and RONALD GREEN
Southwest Research Institute, Geosciences and Engineering Division,
6220 Culebra Rd., San Antonio, TX 78238 USA

High-resolution electrical resistivity imaging provides a non-intrusive means for detecting the presence of solutional features (e.g., caves, solution cavities, and sinkholes) in karst terrains. These imaging techniques have been applied to a variety of karst terrains in central and south-central Texas mostly for the purpose of delineating solutional features in the near-subsurface (i.e., 30 m or less). In this study, depth-of-investigation and resolution are compared using 2-D and 3-D electrical resistivity surveys as well as different electrode array configurations, dipole sizes, and number of electrodes. Evaluation of various 2-D array configurations performed over the same area can provide important information regarding the array types strengths and weaknesses. Ambiguity in the interpretation of the mapped features is minimized by increasing from a 2-D to a 3-D survey technique. Furthermore, depth of penetration is increased by employing the pole-dipole array versus dipole-dipole array. 2-D and 3-D electrical resistivity surveys can enhance the ability to detect karst features in the near-subsurface, however, further optimizations in the survey styles can greatly increase the resolution and depth of investigation.

1. Introduction

Cretaceous limestones of the Edwards Group, Glen Rose Formation, and Austin Chalk are present at or near the ground surface over large parts of south and south-central Texas. Areas of extensive karst terrain within these formations are distributed in the Balcones Fault Zone, the Edwards Plateau, and the river basins of Cibolo Creek and the Guadalupe River. Karst terrain is generally characterized by sinkholes and caves formed by dissolution of limestone bedrock and can be a potential hazard to man-made structures (e.g., homes and buildings) and infrastructures (e.g., highways and pipelines). In karst terrains, geotechnical evaluation for foundation, highway, and pipeline design often requires subsurface characterization to locate significant voids that may affect construction activities. However, without the aid of surface expression, such as a sinkhole or pit, the likelihood of detecting a cave or solution cavity using conventionally-spaced geotechnical borings is low. Likewise, the delineation of a cave or cave network using one-dimensional borings or other geotechnical methods, such as trenching, is uncertain, expensive, and time-consuming.

Electrical resistivity imaging is a non-intrusive geophysical method used to measure and model geoelectrical variations in the subsurface. Electrical resistivity imaging is well suited for detecting the presence of karst features because air-filled voids have a distinctly different electrical signature (i.e., highly resistive) when compared to the surrounding rock and sediment. Two-dimensional (2-D) electrical

resistivity imaging provides cross-sectional representation of a volume of geologic media along a linear transect and can greatly improve detection of subsurface voids. Three-dimensional (3-D) electrical resistivity imaging provides an interpretation of a geologic media in a defined 3-D volume (i.e., block) by combining measurements along evenly spaced parallel and perpendicular transects. 3-D electrical resistivity imaging is an excellent method for detecting and mapping the true geometry of karst features.

Several array types (i.e., electrode configurations) are commonly employed for collecting electrical resistivity measurements. These include but are not limited to dipole-dipole, pole-dipole, pole-pole, Wenner, Schlumberger, and combination Wenner/Schlumberger. Each array type has advantages and disadvantages in terms of investigation depth, signal strength, and resolution (i.e., sensitivity to horizontal and vertical material variations). For example, dipole-dipole, pole-dipole, and pole-pole arrays are most frequently used for 3-D resistivity measurements because other array types have weaker data coverage near the edges of the survey grid (Loke, 2000). Selection of the array type used for resistivity measurements in karst terrains is important because these terrains are generally lithologically and structurally complex. These complexities lead to abrupt changes in the material properties of rocks and sediments over short distances (e.g., a few meters), which may be difficult to resolve using certain array types. This paper presents a number of case studies illustrating how proper survey design (e.g., selection of electrode spacing

and array type) can minimize ambiguity and enhance the interpretation of karst features in the near-subsurface.

2. Case Studies

2.1. Dipole-dipole versus Wenner/Schlumberger

Electrical resistivity measurements were collected along a 288 m linear transect that intersected the presumed trend of a large cave in the Edwards Group of south-central Texas (Fig. 1). Measurements were collected with 3-m electrode spacing and 96 electrodes. The goal of this survey was to identify the trend of the cave beyond a collapse section.

Two array types with identical parameters were used along the same transect, the dipole-dipole array and the Wenner/Schlumberger array. Both of these array types successfully imaged the trend of the cave and by comparing the two we were able to identify the strengths and weaknesses of each configuration.

Figure 1 shows that the Wenner/Schlumberger array penetrates 12 m deeper than that of the dipole-dipole

array. However, the greater depth of penetration comes at the expense of signal strength and resolution. In addition, the acquisition time of the Wenner/Schlumberger array is approximately three times longer than the dipole-dipole array. Prior knowledge of the study area as well as project schedule is generally what drives survey design, however, it is important to be familiar with the various options so that the optimal parameters are selected.

2.2. 3-D versus 2-D survey design

As previously mentioned, 2-D and 3-D electrical resistivity surveys are used to delineate features in the near-subsurface. In this case we illustrate the advantage of using a 3-D survey design over a 2-D survey design to delineate and map shallow subsurface void.

Electrical resistivity measurements were collected along a 2-D transect (Transect-1) and two 3-D survey grids (Grid-1 and Grid-2) over the suspected location of cave in northern San Antonio, Texas called Dead Deer Cave (Fig. 2). The objective of the survey was to identify the location of the

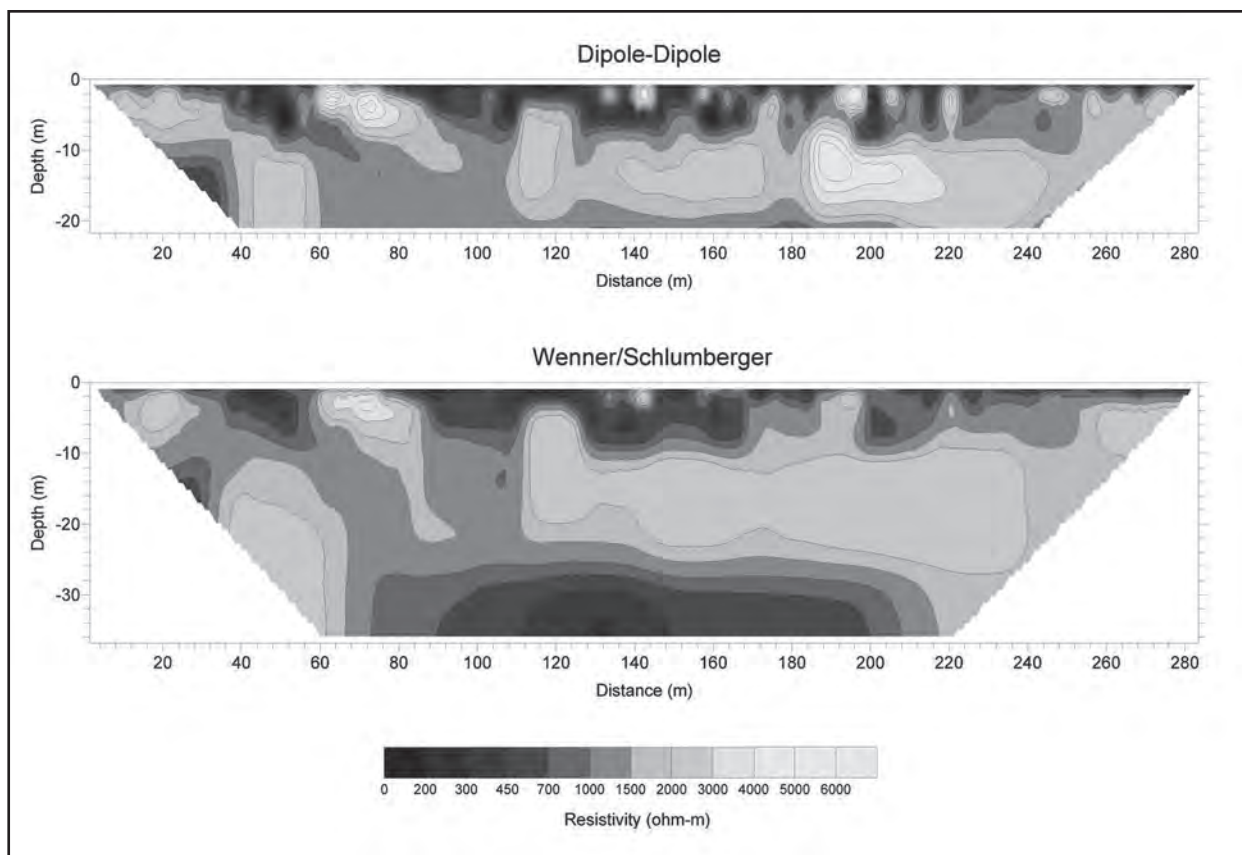

Figure 1: Vertical cross sections of electrical resistivity collected with a dipole-dipole array (top) and a Wenner/Schlumberger array (bottom). Lower resistivity is denoted by dark colors and is interpreted to be shale- or marl-rich limestone. Higher resistivity is denoted by light colors and is interpreted to be massive limestone. The highest resistivity is denoted by white and is interpreted to be potential solutional cavities.

pit entrance to the cave. As a result of a fatal injury and cave rescue in 1975, the pit entrance to the cave was filled with dirt and rock to prevent access to the cave. Over the ensuing years the location of the cave entrance has been lost due to residential and commercial development in the area.

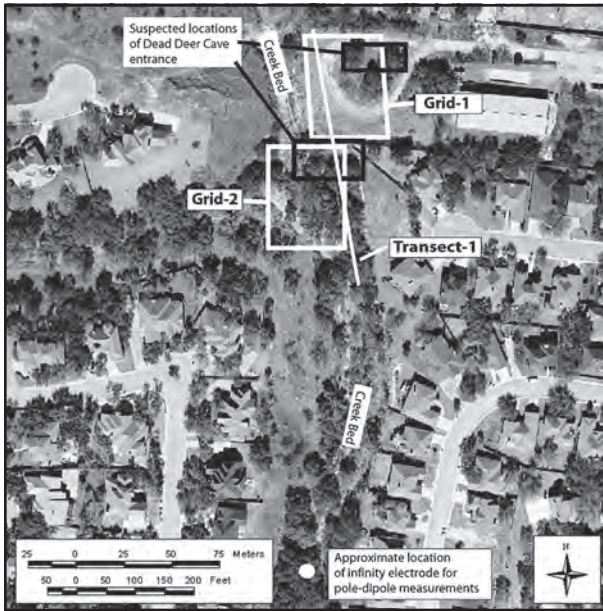

Figure 2: Locations of electrical resistivity transects and grids occupied at suspected locations of Dead Deer Cave.

Dipole-dipole measurements were collected along Transect-1 and pole-dipole measurements were collected over Grid-1 and Grid-2. The 2-D transect consisted of 72 electrodes at 2 m electrode spacing. This survey design allowed the geoelectrical properties of the subsurface to be measured to a depth of approximately 18 m. The 3-D survey consisted of 12 x 8 electrode grids at 5 m electrode spacing. This survey

design allowed the geoelectrical properties of the subsurface to be measured to a depth of approximately 25 m. A pole-dipole array was used for the 3-D survey. This array requires a remote current electrode, known as an “infinity” electrode, to be placed outside the survey grid. In this case, the infinity electrode was placed approximately 200 m south of the survey grids (see Fig. 2).

The 2-D resistivity survey results are presented in Figure 3 as a cross-section of inverted resistivity and the 3-D resistivity survey results are presented in Figure 4 as block diagrams of inverted resistivity. Modeled electrical resistivity values in the shallow subsurface at the site range from less than 10 to greater than 3500 ohm-m for the 2-D dipole-dipole measurements, and from approximately 50 to 800 ohm-m for the 3-D pole-dipole measurements.

The 2-D survey results show a continuous zone of high resistivity in the shallow subsurface extending from approximately 25 m to 130 m along Transect-1. The highest modeled resistivity values are present in the northern part of the transect at approximately 75 m to 125 m. These high resistivity zones are interpreted as potential open space associated with Dead Deer Cave. A zone of relatively high resistivity is observed in the modeled data to be within a few meters of the ground surface at approximately 78 m to 88 m along the transect.

For the 3-D measurements, block models of x-slices of inverted resistivity and block models of volume rendering of inverted resistivity for values < 400 ohm-m are illustrated in Figure 4. The block diagrams of x-slices of inverted resistivity show relatively large, laterally continuous zones

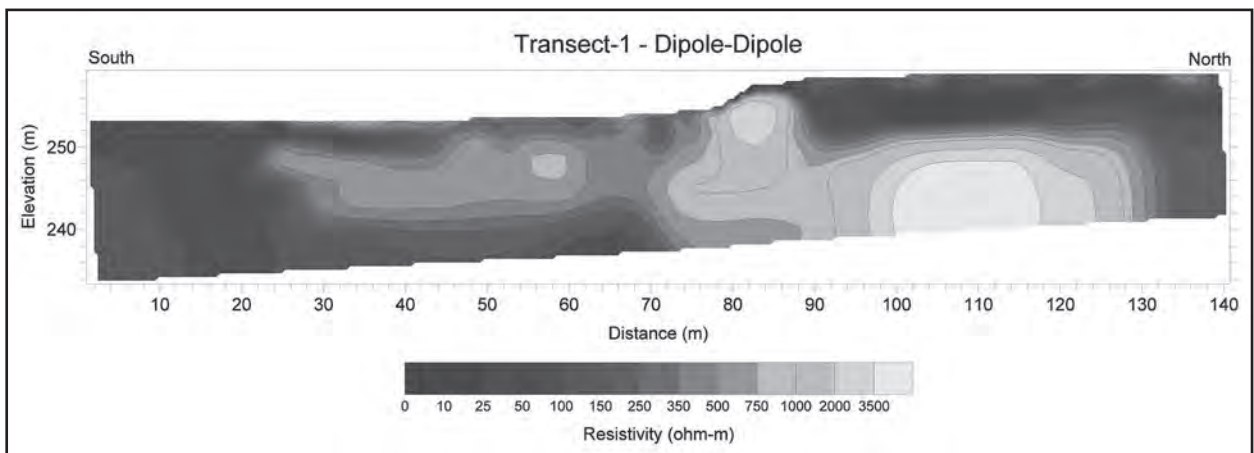

Figure 3: Vertical cross sections of electrical resistivity collected with a dipole-dipole array (top). Lower resistivity is denoted by dark colors and is interpreted to be surface soil or shale- or marl-rich limestone. Higher resistivity is denoted by light colors and is interpreted to be a massive limestone. The highest resistivity is denoted by white and is interpreted to be a potential solution cavity.

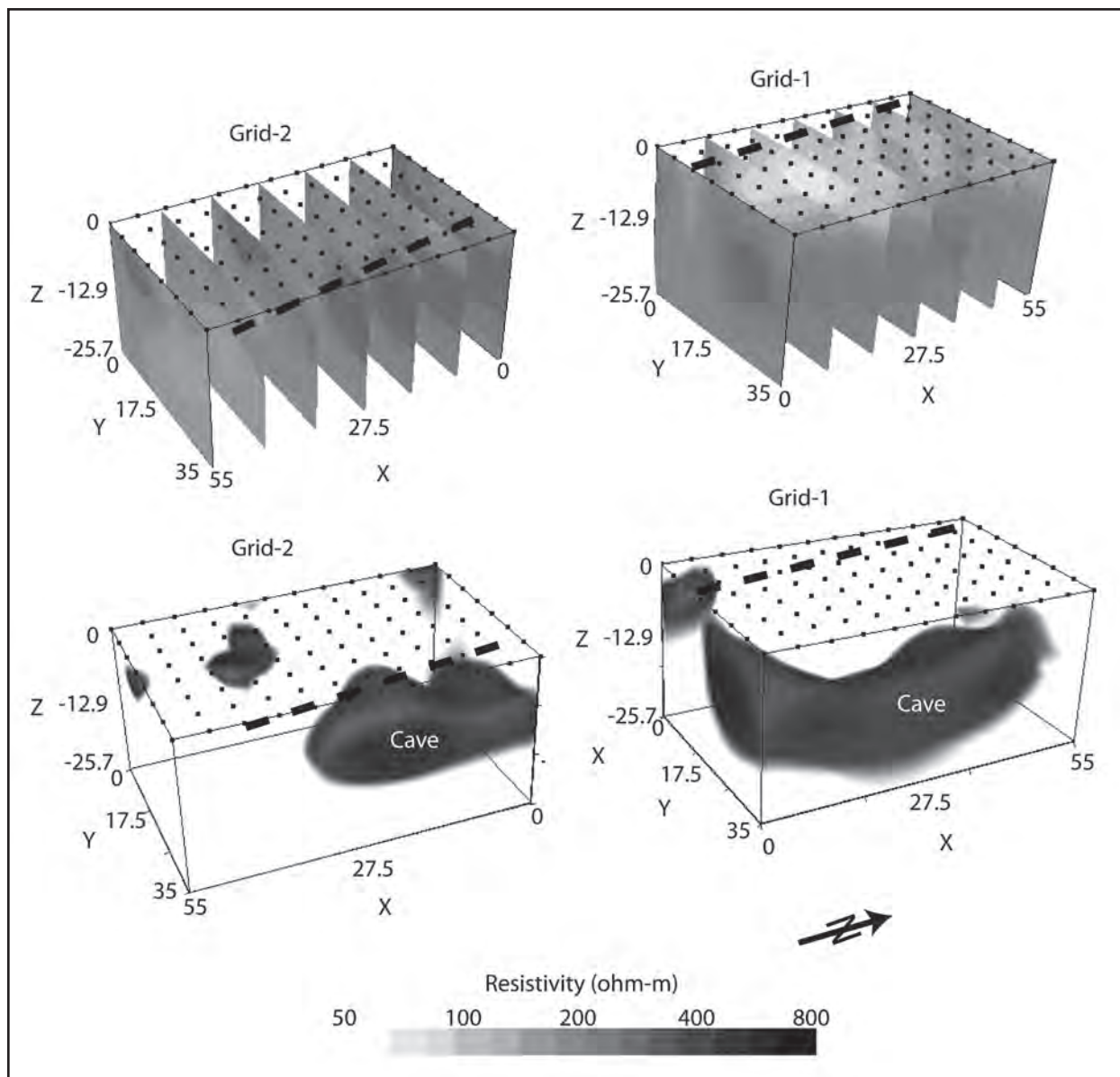

Figure 4: Block models of x-slices and volume rendering of inverted resistivity for pole-dipole measurements collected at Grid-1 and Grid-2. The block models are positioned to show the south to north variation in subsurface electrical resistivity beneath the surveyed areas. Dashed lines represent the placement of Transect 1.

of high resistivity in the eastern half of Grid-1 and in the east-northeast part of Grid-2. The laterally continuous zones of high resistivity trend south-north and are present at or near the ground surface at depths of approximately 10 m in Grid-1 and to depths of approximately 5 m in Grid-2. These high resistivity zones are interpreted as open voids associated with the Dead Deer Cave. Volume rendering of inverted resistivity for values < 400 ohm-m illustrate the potential extent of the laterally continuous, south-north trending void space in the eastern half of Grid 1 and beneath the northeastern part of Grid-2. Zones of high resistivity (i.e., > 400 ohm-m) come within a few meters of

the ground surface along the southern boundary of Grid-1 at approximately 10 m and along the eastern boundary of Grid-1 at approximately 35 m.

Both the 2-D and 3-D electrical resistivity measurements were able to detect potential subsurface voids associated with Dead Deer Cave. However, the increased areal coverage of the 3-D measurements allowed for better delineation and resolution of potential voids. For example, the modeled 3-D measurements indicated that potential voids associated with high resistivity areas in the subsurface are located along the eastern boundary of Grid-1. These potential voids are

located 10 m or more to the east of the 2-D measurements collected along Transect-1. The shape, orientation, and depth of the volume rendering of inverted resistivity for modeled pole-dipole resistivity values correspond well to the description of Dead Deer Cave (Veni, 1988).

Acquisition time and cost can control whether a 2-D or 3-D survey design is used. While the 3-D design provides enhanced data coverage of the near-subsurface it takes considerably longer to perform the survey and thus the cost of the project is higher.

2.3. 3-D dipole-dipole versus 3-D pole-dipole survey design

In this case, we compare 3-D electrical resistivity measurements collected over a building construction site to illustrate the increased depth of penetration and resolution achieved using the pole-dipole array versus the dipole-dipole array. Concerns at the building site were encountered when a cave within the Edwards Group was encountered while drilling foundation piers for a multistory office building in northern San Antonio, Texas. The void was encountered at

a depth of approximately 6 m and extended to a depth of 10 m. A 3-D electrical resistivity survey was conducted over a 55 m x 42 m area covering the footprint of the proposed building. Continuous dipole-dipole and pole-dipole measurements were collected across a 12 x 8 electrode grid with 5 m x 6 m electrode spacing.

The 3-D resistivity survey results are presented as block diagrams of inverted resistivity and volume renderings of inverted resistivity in Figure 5. The electrical properties of the geologic section beneath the electrode grid were measured to a depth of approximately 12 m for the dipole-dipole measurements and approximately 25 m for the pole-dipole measurements.

The block diagrams of inverted resistivity show continuous zones of high resistivity (800–1200 ohm-m) at or near the ground surface and are surrounded or encased in zones of low to intermediate resistivity (100–300 ohm-m; Fig. 5). An isolated zone of high resistivity (2000–4000 ohm-m) occurs at a depth of about 6 m in the southeastern corner of the site. This isolated zone of high resistivity (2000–4000

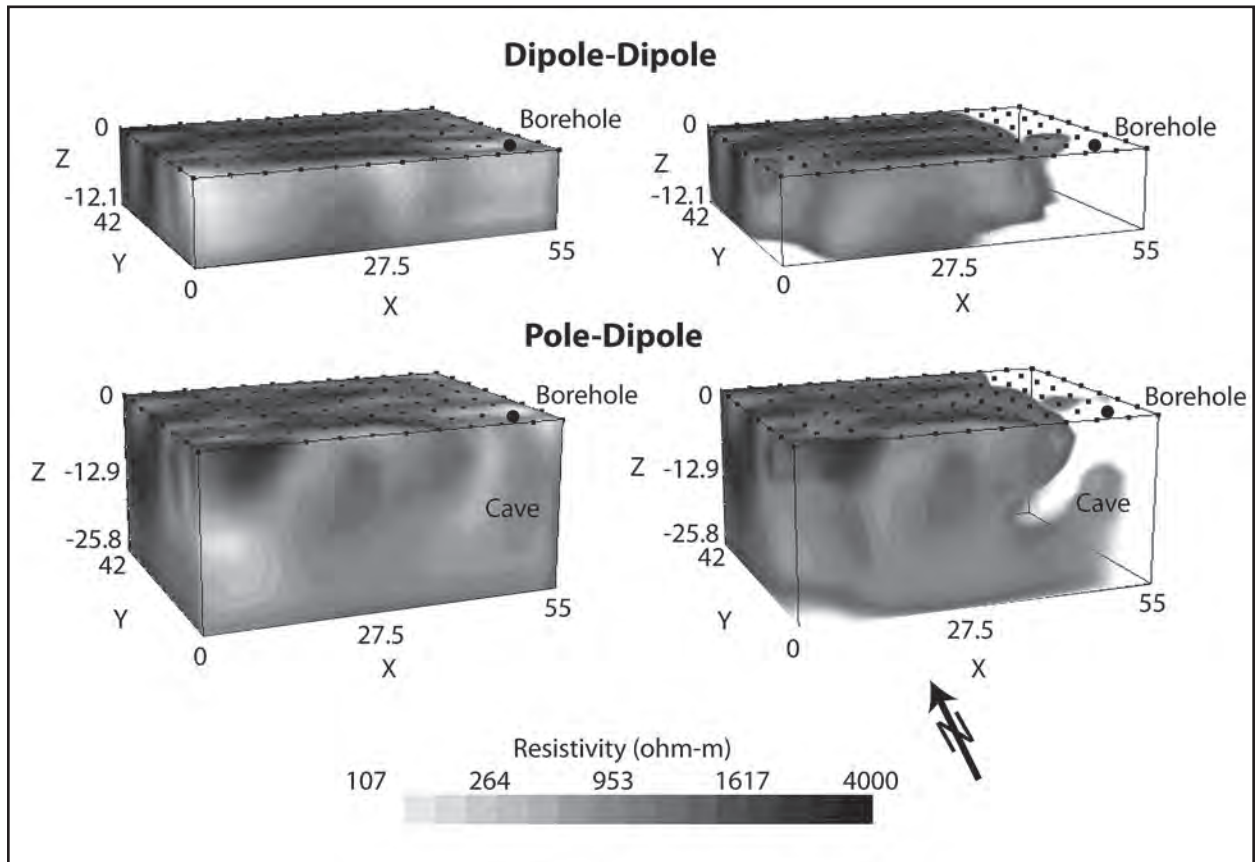

Figure 5: Block models and volume rendering of inverted resistivity for dipole-dipole and pole-dipole measurements collected at site in northern San Antonio, TX. The block models are positioned to show the west to east variation in subsurface electrical resistivity beneath the surveyed areas.

ohm-m) trends vertically and corresponds to the location of the cave that was encountered during drilling for the emplacement of piers along the periphery of the planned building. Zones of high resistivity (800–1200 ohm-m) over most of the site are interpreted as massive, intact limestone of the Edwards Group. Zones of low to intermediate resistivity (100–300 ohm-m) at the site are interpreted as weathered, clay interbedded limestone of the Edwards Group.

This isolated zone is only present in modeled data for the pole-dipole measurements which have the depth of penetration and resolution sufficient enough to image this feature. In this case, if a dipole-dipole array was the only array type used, the void would have not been imaged and further studies would have been necessary.

3. Conclusions

Electrical resistivity surveys using different array types and survey designs were conducted in karst terrains in south and south-central Texas to illustrate the advantages and disadvantages with respect to depth of penetration and resolution. Results indicate that in comparison to 2-D surveys, while time-consuming, the areal coverage and resolution achieved using 3-D surveys are superior for delineating and mapping karst features. In addition, whether a 2-D or 3-D survey design is used, having practical knowledge of the various strengths and weaknesses for multiple array types can enhance survey quality by providing greater depth of penetration and resolution of near-

subsurface karst features.

These results also reveal the importance, when conducting electrical resistivity surveys, of being able to configure and optimize the survey design in multiple ways. Preferably, the design is decided on prior to start of the survey, however, some situations do not allow extensive research of the study site prior to the start of the survey.

References

- LOKE, M.H. (2000) Electrical imaging surveys for environmental and engineering studies, a practical guide to 2-D and 3-D surveys. Copyright (1997, 1999, and 2000) by Dr. M.H. Loke. Available at <http://www.terraplus.com/>
- MORRIS, D.V., M.D. GEHRIG, and J.T. BRYANT, (2005) Detection of three-dimensional voids in karstic ground. In Sinkholes and the Engineering and Environmental Impacts of Karst, American Society of Civil Engineers, Proceedings of Tenth Multidisciplinary Conference, Sept. 24–28, 2005, San Antonio, Tx, 562–571.
- VENI, G. (1988) The Caves of Bexar County Second Edition, Texas Memorial Museum Speleological Monographs, 2, The University of Texas at Austin, Austin, Tx, 300 pp.

PALEOMAGNETISM AND MAGNETOSTRATIGRAPHY OF CAVE SEDIMENTS IN SLOVENIA

PETR PRUNER¹, PAVEL BOSÁK^{1,2}, NADJA ZUPAN HAJNA², ANDREJ MIHEVC²

¹*Institute of Geology AS CR, v.v.i., Rozvojová 269, 165 00 Praha 6, Czech Republic*

²*Karst Research Institute ZRC SAZU, Titov trg 2, 6230 Postojna, Slovenia*

Abstract

In research of karst in Slovenia we have been applying paleomagnetic and magnetostratigraphy method for more than 10 years. The research covered the most important karst regions from lowlands to high mountains, including Classical karst sites. The research extended across an extensive region with different geological structure and geomorphologic situations, containing a number of caves and fragments of cave systems. Good profiles of cave sediments were not abundant, therefore we focused on the most available and accessible ones. Different genetic types of caves were studied – from hypogenic (e.g., Jama pod Babjim zobom) and phreatic ones (e.g., Grofova jama, Zguba jama) to ideal water-table cave systems (e.g., Postojnska jama, Markov spodmol). Results from individual sites and their discussion clearly indicated some similarities in evolution both of caves and their fills. They are also provided information on the evolution of the surface, weathering conditions, pedogenesis, etc.

Dating of cave sediments (flowstones and clastic sediments) by the application of the paleomagnetic method is a difficult and sometimes risky task, as the method is comparative in its principles and does not provide numerical ages. Repeated sampling in some profiles have shown that only dense sampling (high-resolution approach with sampling distance of 2–4 cm), can ensure reliable results. Correlation of the magnetostratigraphic results we obtained, and the interpretations tentatively placed upon them has shown that in the majority of cases, application of an additional dating method is needed to either reinforce the paleomagnetic data or to help to match them with the geomagnetic polarity timescale.

The application of complete paleomagnetic analysis, both by thermal demagnetization and alternating field demagnetization, only to pilot samples and the shortened selected field/step approach to other samples does not offer sufficient data set for interpretation. It is necessary to apply complete demagnetization to obtain reliable data. Measured data should be subjected to multi-component analysis of the remnants. The individual components must be precisely established to determine the ChRM directions. Mean ChRM directions must be analyzed using the statistics for spheres but small number of samples could not be used for a reliable interpretation.

The dynamic character of cave fill deposition is reflected in the start or termination of individual magnetozones at unconformities in a number of profiles, which is comparable with situation reported on a number of Quaternary carbonate platforms. The general character of cave depositional environments with their numbers of post-depositional changes, hiatuses, reworking and re-deposition does not allow precise calculation of the temporal duration of individual interpreted magnetozones. All these factors contribute to the fact that exact calibration of the geometric characteristics of the magnetostratigraphic logs with the GPTS cannot be attained at all or only with problems, if it is not adjusted using results of other dating and geomorphic methods.

GEOPHYSICAL PROSPECTING FOR A MAJOR SPRING CONDUIT IN THE OZARK KARST SYSTEM (MISSOURI, USA) USING AUDIO-MAGNETOTELLURIC (AMT) SOUNDINGS

DAVID J. WEARY, HERBERT A. PIERCE

U.S. Geological Survey, 12201 Sunrise Valley Drive, Reston, VA, 22019, USA, dweary@usgs.gov

Groundwaterflow in karst areas is often poorly understood and difficult to model because of the heterogeneous permeability of karstic aquifers. The Ozark Plateaus of Missouri, in the central United States, contain a well integrated karstic flow system feeding numerous large karst springs. Dye traces have been used to delineate the major groundwater basins; these yield an average flow velocity over a straight-line distance but provide little information on the actual path of groundwater flow. Mapping discrete karst conduits will enable more realistic modeling of the fast flow component of the aquifer. Alley Spring is a large spring located in the Ozark region of southern Missouri. The spring has an average flow of 3.6 m³/sec; it is fed by a single water-filled conduit with a horizontal extent of at least 600 m and an average depth of about 50 m below the spring surface that has been mapped by divers. The conduit is in flat-lying Cambrian and Ordovician dolomites. Audio-magnetotelluric (AMT) data was collected in the vicinity of the spring in an attempt to identify the electromagnetic (EM) signature of the conduit, and to map its probable location.

Unlike induction resistivity techniques, AMT uses natural-source multi-frequency electromagnetic signals from lightning or atmospheric disturbances as an energy source. These AMT soundings consist of electric and magnetic field measurements over a range of frequencies from 10- to 100,000-Hertz with fixed receiver locations. Since low-frequency signals penetrate to greater depths than high-frequency signals, measurements of the EM response at several frequencies contain information on the variation of resistivity at depth. Conduits should be visible in the processed AMT data as volumes of low resistivity due to water-saturated rock as well as electrical streaming potential oriented along the conduit. Advantages of AMT over most other resistivity methods are portability of equipment and depth of exploration, typically about 1 Km. The AMT sensors are two ground electrodes and two magnetic coils, and can be set up by one person and require an area of about 50m x 50m. A team of 2 persons can easily collect about six to eight soundings per day. Traditional resistivity studies require line lengths 4-5 times the intended depth of investigation, limiting their use as reconnaissance tools. Although resolution is limited to discrete anomalies about 250 m wide, AMT surveys should be adequate for use in regional groundwater models.

Preliminary analysis of the data from Alley Spring indicates a high resistivity anomaly, corresponding to the Alley Spring orifice and known cave extending to the west and northwest along the same general azimuths as incoming dye traces. Data from a line of soundings orthogonal to the trends of 2 dye traces and collected 7.5 km WNW of the spring show a high resistivity anomaly that might indicate the main spring conduit or a major subsurface tributary.

1. Introduction

Groundwaterflow in karst aquifers is poorly understood and difficult to model in part because of the heterogeneous permeability of the rocks. Primary permeability in telogenetic Paleozoic carbonate rocks is commonly very low, but flow through secondary features such as solution conduits may be very high. The Ozark Plateaus physiographic Province (FENNEMAN AND JOHNSON, 1946) of Missouri, USA contains a well integrated karstic

flow system developed chiefly in Cambrian and Ordovician dolomitic rocks. Most caves in the study area are relatively horizontal, single-level, strata-bound, and have simple branchwork patterns. Developing the ability to map the approximate locations of individual karst conduits will enable more realistic modeling of the fast-flow component of the aquifer. Alley Spring was selected for this study because 1) the geologic setting is well known; 2) the spring is fed by a single, water-filled conduit with a known extent

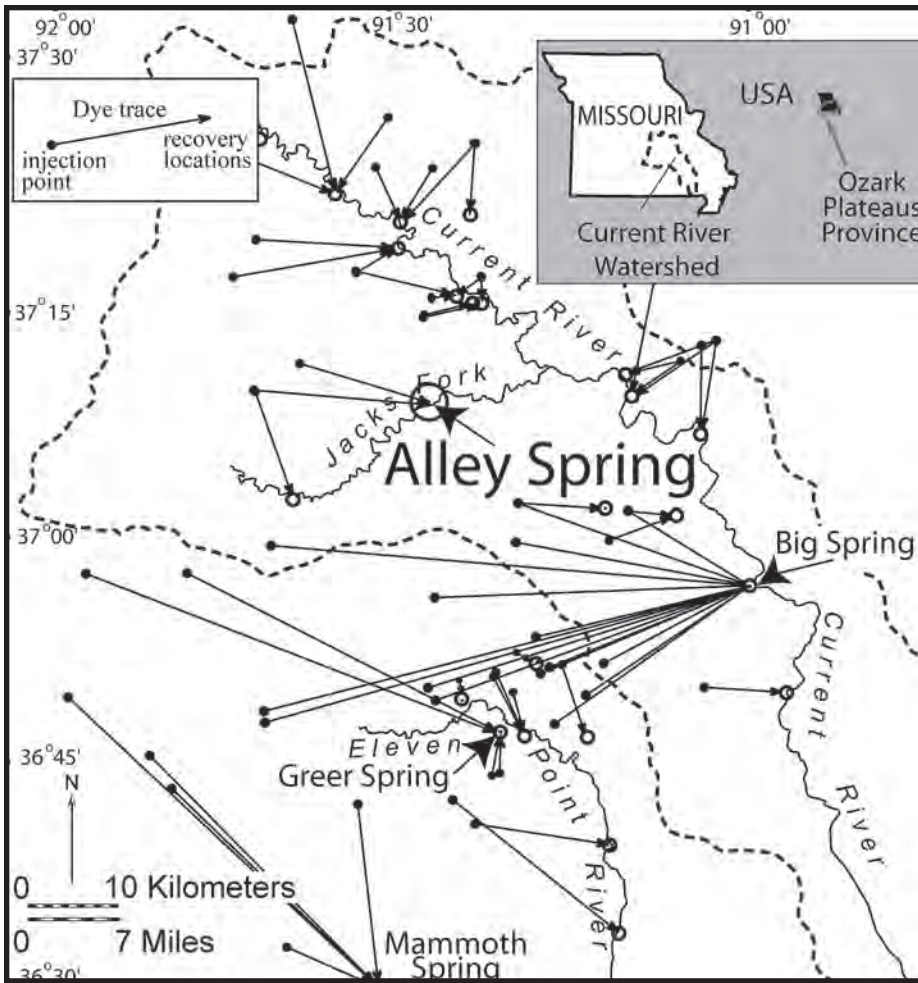

Figure 1: Location of Alley Spring in relationship to dye traces and other large springs in southern Missouri. Dye Traces from IMES and KLEESCHULTE (1995), ALEY and ALEY (1987).

of about 1970 ft (600 m) to the west of the rise pool; and, 3) dye traces that indicate groundwater flow for long distances from west of the spring (Fig 1).

The bedrock in the study area is chiefly horizontal to gently-dipping dolomite of Cambrian and Lower Ordovician age with minor amounts of quartz sandstone and chert (Fig. 2). Alley Spring rises from the lower part of the Gasconade Dolomite, but is supplied by a large conduit formed in the upper part of the Eminence Dolomite. Most of the water supplying the spring is the result of precipitation infiltrating the overlying Roubidoux Formation, much of it via sinkholes, in upland areas several miles to the west (ALEY AND ALEY, 1987).

About 910 m of Alley Spring Cave has been

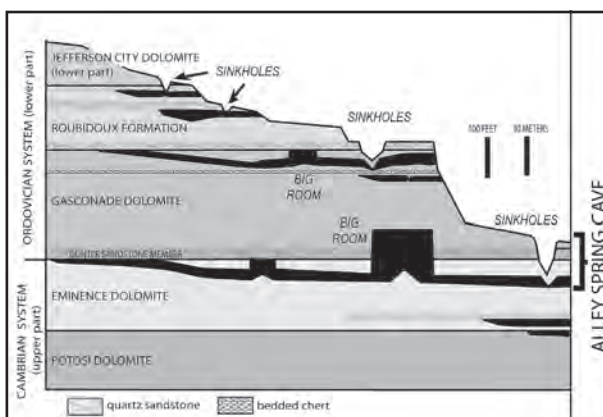

Figure 2: Stratigraphic level of the known part of Alley Spring Cave (black bracket) in relation to a conceptual model of stratigraphic control on cave elevations in the Ozarks of southern Missouri (from ORNDORFF, et al 2006). Note similarity of the known cave profile(Fig.3) to this conceptual model which was originally drawn in 2001.

mapped by divers of the Ozark Cave diving alliance (2005). The cave descends at an angle of about 24° to the northwest of the spring where it levels out at a stratigraphic level coincident with the top of the Eminence Dolomite, at a depth of about 38 m below the surface, (Fig. 3). The mapped portion of the conduit is relatively horizontal with the elevation of the main conduit at about 162 meters. The cave maintains this level for the rest of its known extent, except where collapses of the overlying basal Gunter Sandstone Member of the Gasconade Dolomite occur and the conduit has migrated vertically over the top of the resulting breakdown piles. This architecture is typical of many caves in this part of the Ozarks (ORNDORFF et al., 2006) (Fig. 3).

2. Audio-Magnetotelluric Study

Audio-magnetotelluric (AMT) methods were used in this investigation to characterize and better understand the properties of the ground underlying the area near Alley Spring. AMT soundings are made to determine

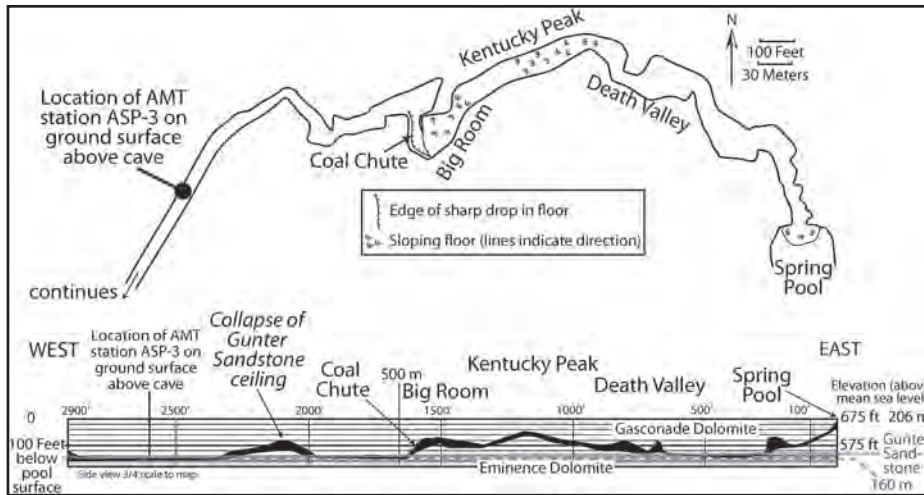

Figure 3: (A) Map and profile of Alley Spring Cave simplified from a map produced by the Ozark Cave Diving Alliance (OCDA, 2005). Geologic interpretation by D. Weary, based on surface geologic mapping, observations by OCDA divers, video footage, and analogy to geologic control seen in air-filled caves in the region. Dashed line indicating 160 m elevation is the level of the electromagnetic resistivity map (Fig. 8).

variations in the electrical resistivity of the earth with depth (CAGNIARD, 1950, 1953; TIKHONOV, 1950; WAIT, 1962; KELLER AND FRISCHKNECHT, 1966; HOOVER AND LONG, 1976; HOOVER et al., 1976; HOOVER et al., 1978; DMITRIEV AND BERDICHEVSKY, 1979; VOZOFF, 1986, 1991). The AMT method uses natural-source multi-frequency electromagnetic signals from lightning or atmospheric disturbances as an energy source. These natural signals diffuse into the earth and the diffusion governs the electromagnetic induction.

These AMT soundings consist of electric and magnetic field measurements over a range of frequencies from 10- to 100,000-Hertz with fixed receiver and transmitter locations. The distribution of currents induced in the earth depends on the earth's electrical resistivity, earth's magnetic permeability, and frequency measured. Since low-frequency signals penetrate to greater depths than high-frequency signals, measurements of the electromagnetic (EM) response at several frequencies contain information on the variation of resistivity at depth.

The electrical impedance tensor \underline{Z} is complex, comprising both real and imaginary parts. Each component of Z_j of \underline{Z} has not only a magnitude, but a phase as well. The fluctuating (AC) natural electric (E) and magnetic (B) fields are measured in orthogonal directions at the surface of the Earth. The orthogonal components of the horizontal electric and magnetic fields are related by a complex impedance tensor, \underline{Z} , defined as:

$$\begin{pmatrix} E_x \\ E_y \end{pmatrix} = \begin{pmatrix} Z_x & Z_y \\ Z_y & Z_x \end{pmatrix} \begin{pmatrix} B_x / \mu_0 \\ B_y / \mu_0 \end{pmatrix}$$

From the impedances, resistivities and phases as a function of frequency are calculated:

$$\rho_{aj(\omega)} = \frac{1}{\mu_0 \omega} |Z_j(\omega)|^2$$

$$\phi_j = \tan^{-1} \left(\frac{\text{Im} \{ Z_j \}}{\text{Re} \{ Z_j \}} \right)$$

Where ρ_a is the frequency dependent apparent resistivity, μ_0 is the magnetic permeability of free space, ω is the angular frequency, Z_j is

the impedance, ϕ_j is the phase angle, Im is the imaginary term, and Re is the real term. The resistivities and phases are inverted as a function of depth then cross-sections and electrical maps at various depths are constructed to provide images of the electrical response associated with folded and fractured geologic structures (Mackie and others, 1997).

3. Audio-Magnetotelluric Survey of Alley Spring

Our study was designed on the assumption that water saturated rock is less resistive than dry rock and that large conduits containing flowing water will present themselves as low resistivity anomalies in AMT profiles and maps that intersect them. During calendar years 2006-2008 forty-one Audio-magnetotellurics (AMT) soundings were collected; 35 in an array covering about 12 km² in proximity (within 2.9 km) to Alley Spring, and 6 in a north-trending line about 3.5 km long, located about 7.5 km to the west-northwest of the spring (Fig. 4). This design was intended to provide adequate data for resolving resistivity anomalies near the spring and cave so that the relationship of the conduit to the anomalies could be confidently identified. The line of stations acquired to the west-northwest was to provide data to construct a resistivity profile that might indicate the location of conduits supplying the spring along the trend of the dye traces. Attempts was made to space stations evenly at 250 m intervals, however inadequate access to various locations, unsuitable topography, and proximity to cultural features such as fence lines and power lines required locational adjustments and irregular station spacing.

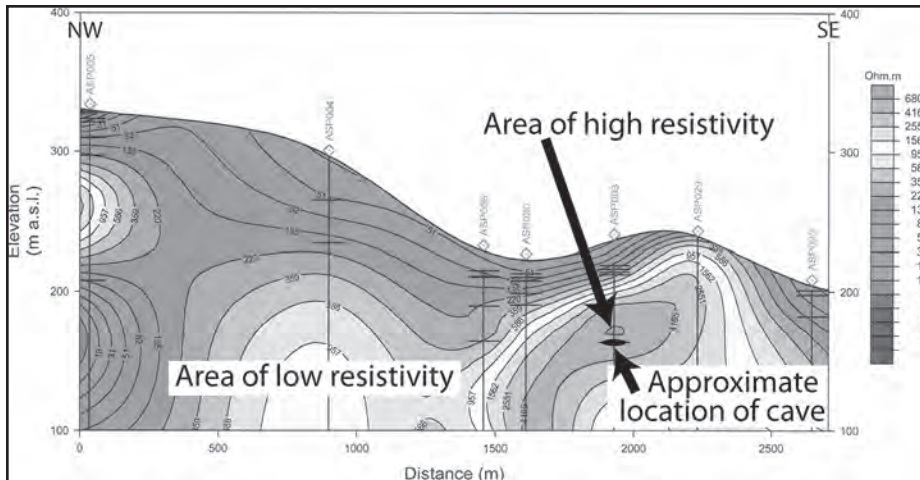

Figure 4: Location of audiomagnetotelluric sounding stations in vicinity of Alley Spring. The northern dye trace extends 10.9 miles (17.5 km) from the northwest, the southern trace extends 14 miles (22.4 km) from the west northwest. The trace of the Hartshorn fault (USGS unpublished data) approximately coincides with the Alley Hollow lineament of ALEY AND ALEY (1987). Contours indicate 200 and 300 meter (656 and 984 feet) elevations.

AMT soundings were recorded using a Geometrics EH-4 system. No vertical magnetic field (H_z) data were recorded because the system is limited to four channels (E_x , E_y , H_x , and H_y). About 2000 frequencies were collected and then reduced to approximately 40 frequencies for each direction (E_x and E_y) from 10- to 100,000-Hertz. The EH-4's system includes a 60 Hz notch filter to reduce interference from energized utility lines. Inversions that are invariant with rotation angle were chosen to assess the data and models in order to compare them with the known geology and hydrology.

The 2-dimensional invariant electrical sections are generated using a smooth-model inversion routine that finds regularized solutions (Tikhonov Regularization) to the two-dimensional inverse problem for magnetotelluric data. The model uses nonlinear conjugate gradients (MACKIE et al., 1977). A uniform half-space of 1000 ohm-meters was used as a starting model for the 2-D inversions. Once a series of 2-dimensional models are generated, resistivity cross sections and associated maps can be made of different depths below

land surface. The electrical sections and maps at various depth slices are compared with the known surficial geology, borehole data, and hydrologic information. Additional hydrologic and geologic interpretations can be made and the interpretations modified.

If geologic structures are assumed to be two-dimensional, the impedance tensor Z can be rotated to an angle corresponding to the strike of the geology. Because we did not have a vertical magnetic coil, induction arrows (tipper),

vectorial representations of the complex ratios of vertical to horizontal magnetic field components, were unavailable. Tensor rotation solutions were based on a principal axis approach to maximize E_{xy} and minimize E_{yx} .

4. Results

Three electromagnetic resistivity profiles were generated from the sounding data along three lines: two in the vicinity of the spring and known cave, and one about 7.5 km to the west northwest of the spring (Figs. 5, 6 and 8). Line P-4 (Fig. 5), the closest line to the known cave reveals a pronounced resistivity high centered on the approximate location of the mapped conduit (Fig. 5). Line P-3 (Fig. 6), located about 1.8 km to the west of the mapped cave exhibits a more

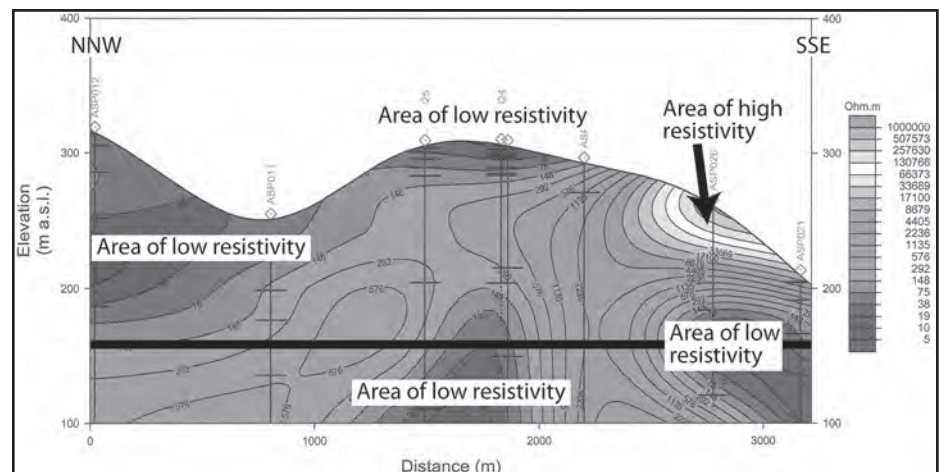

Figure 5: Audio-magnetotelluric and topographic profile line P-4. Location and elevation of cave is estimated from cave map and side view (Fig. 4). 3X vertical exaggeration. See Figure 5 for line and station locations.

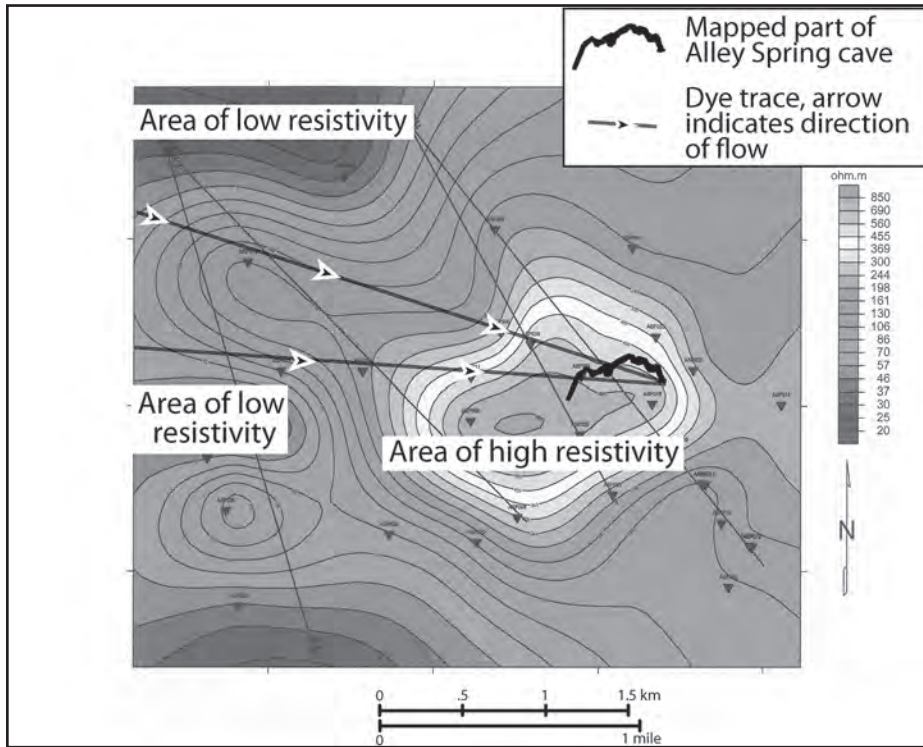

Figure 6: Audio-magnetotelluric and topographic profile line P-3. 3X vertical exaggeration. See Figure 5 for line and station locations. Black line marks approximate elevation of the known cave to the east (160 m) for reference.

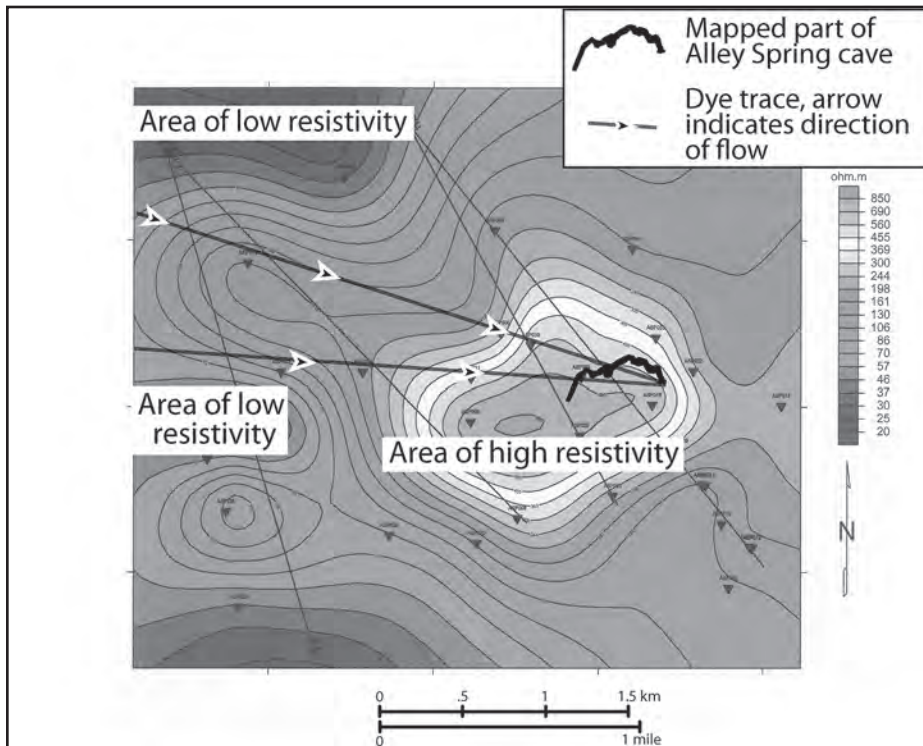

Figure 7: Subsurface electromagnetic resistivity map and structural contours in the vicinity of Alley Spring. Resistivity map generated at the 160 meter elevation (525 foot) (above mean sea level). See Figure 4 for vertical relationship to the Alley Spring Cave.

subtle pattern of high and low resistivity areas. An interpolated resistivity map of the densely sounded area near Alley Spring was generated at the 160 meter elevation level to coincide with the main level of the mapped cave (Fig. 7). This map shows a dramatic resistivity high, in the area of the known cave, with two lobes of lesser, but still high, resistivity extending to the west and northwest.

The AMT profile generated for the line to the west of the spring area (Fig. 8) indicates a high resistivity anomaly near its north end adjacent to the Hartshorn fault and centered on an elevation of about 200m. An area of lower resistivity occurs near the center of the profile and another area of relatively high resistivity occurs in the southern part of the profile.

5. Interpretation and Discussion

The results of this study are, at this writing, still preliminary. The AMT data are still being analyzed and methodologies being developed for best identifying and displaying resistivity anomalies associated with conduits. When first designed, it was assumed that the flowing water-filled conduit for Alley Spring would be represented in the AMT data as low apparent resistivity anomalies since water saturated rocks are usually less resistive than

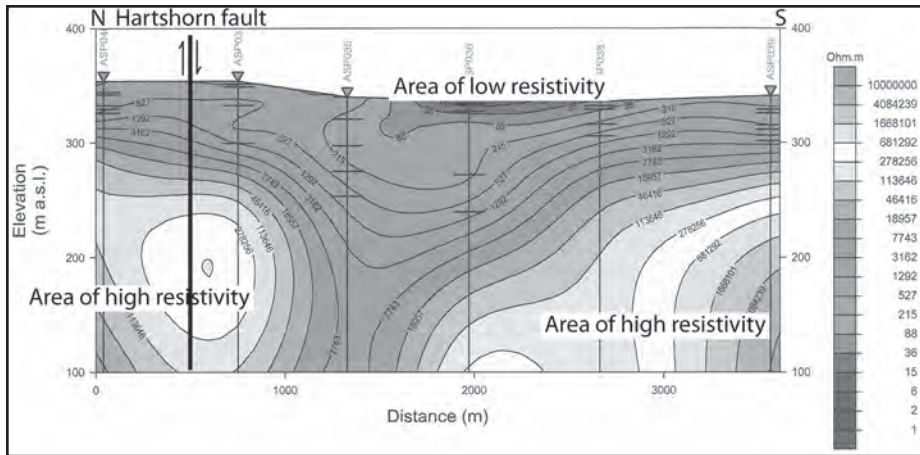

Figure 8: Audio-magnetotelluric and topographic profile line "Western Trace". See Figure 4 for line and station locations. 3X vertical exaggeration.

dry rock. This is a pattern we have observed in other study areas where Groundwaterflow was more diffuse (KOZAR et al., 2007). At Alley Spring, the known conduit location appears to coincide with areas of high apparent resistivity (figs. 5 and 7). This suggests that the flow of water in the conduit is generating an electrical streaming potential and a strong electrical field, relative to the magnetic field. The calculation of apparent resistivity (see section 2) is partially dependent on the impedance:

$$Z_j = \frac{E_i}{H_j}$$

Where Z_j is the impedance E_i is the electrical field, and H_j is the magnetic field. Since the electrical field term is in the numerator, higher values of electrical field strength will cause the impedance value to be large and result in high apparent resistivities. If it is assumed that this relationship continues away from the known extent of the conduit, the relatively high resistivity areas between the low resistivity anomalies identified on AMT section P-3 (Fig. 6) may indicate conduit locations. There are 2 areas of high resistivity on this profile (Fig. 6) coinciding with 2 high resistivity lobes on the electrical resistivity map (Fig. 7) at 160m elevation that extend to the west and northwest from the high resistivity anomaly associated with the know cave. This may indicate that the conduit has branched into 2 tributaries.

Interpretation of the Western Trace AMT profile (Fig. 8) is even more speculative. The circular high-resistivity anomaly near the north end of the line suggestively coincides laterally with the location of the Hartshorn fault and is vertically (about 200 m (656 ft) elevation) consistent with an inferred low-gradient conduit connected to Alley Spring. The potentiometric surface in this area is at an elevation lower

than 297 m based on the perennially dry bottom of the large Forty Acre Sinkhole nearby (Fig. 4). ALEY AND ALEY (1987) speculated that their Alley Hollow lineament which is coincident with the trace of the Hartshorn fault, was involved in guiding groundwater flow towards Alley Spring from areas to the northwest of the Northern trace. BRIDGE (1930, p. 41) relates substantiated anecdotal

reports that a sinkhole collapse to the northwest of the Western Trace interrupted the flow of Alley Spring for about 12 hours in the 1920s.

6. Conclusions

The AMT method is showing potential for mapping large conduits with flowing water. There appears to be a correspondence between high resistivity electromagnetic anomalies and known positions of the Alley Spring Cave which is believed to be caused by the streaming potential generated by the large volume of flowing water in the conduit. At this point, results and interpretations of data collected away from know features is speculative is very unreliable without some *a priori* knowledge of the conduit system or other corroborating evidence.

References

- ALEY, T.J., and C. ALEY, (1987) Groundwater study— Ozarks National Scenic Riverways. National Park Service Contract CX 6000-4-0083, 222 pp.
- BRIDGE, J. (1930) *Geology of the Eminence and Cardareva quadrangles*. Missouri Bureau of Geology and Mines, 2d ser., 24, 228 pp., scale 1:62,500.
- CAGNIARD, L. (1950) Procedure of geophysical prospecting. French patent no. 1025683.
- CAGNIARD, L. (1953) Basic theory of the magneto-telluric method of geophysical prospecting. *Geophysics* 18, 605–635.
- DMITRIEV, V.I. and M.N. BERDICHEVSKY, (1979) The fundamental model of magnetotelluric sounding. *Institute of Electrical and Electronics*

Engineers Proceedings, **67**, 1034–1044.

- FENNEMAN, N.M. and D.W. JOHNSON, (1946) *Physiographic divisions of the conterminous U. S.* U.S. Geological Survey special map series, scale 1:7,000,000.
- HOOVER, D.B. and C.L LONG, (1976) Audio-magnetotelluric methods in reconnaissance geothermal exploration. *Proceedings of the 2nd United Nations Symposium for the Development of Geothermal Resources*, 1059-1064.
- HOOVER, D.B., F.C. FRISCHKNECHT, and C. TIPPENS, (1976) Audio-magnetotelluric soundings as a reconnaissance exploration technique in Long Valley, California. *Journal of Geophysical Research*. **81**, 801–809.
- HOOVER, D.B., C.L. LONG, and R.M. SENTERFIT, (1978) Some results from audio-magnetotelluric investigations in geothermal areas: *Geophysics*, v. **43**, 1501–1514.
- IMES, J.L. and M.J. KLEESCHULTE, (1995) Seasonal ground-water level changes (1990-93) and flow patterns in the Fristoe Unit of the Mark twain National Forest, southern Missouri. U.S. Geological Survey Water-Resources Investigations Report 95-4096, 1 sheet.
- KELLER, G.V. and F.C. FRISCHKNECHT, (1966) *Electrical methods in geophysical prospecting*: London, Great Britain, Pergamon Press, 519 pp.
- MARK D. KOZAR, KURT J. MCCOY, DAVID J. WEARY, MALCOLM S. FIELD, HERBERT A. PIERCE, WILLIAM BANE SCHILL, and JOHN A. YOUNG (2007) Hydrogeology and Water Quality of the Leetown Area, West Virginia: U.S. Geological Survey Open-File Report 2007–1358, 109 pp.
- MACKIE, R.L., S. RIEVEN, and RODI, W. (1977) *User's Manual and Software Documentation for Two-Dimensional Inversion of Magnetotelluric Data*: San Francisco, GSY-USA Inc., 125 pp.
- ORNDORFF, R.C., D.J. WEARY, and R.W. HARRISON, (2006) The role of sandstone in the development of an Ozark karst system, south-central Missouri, in *Perspectives on karst geomorphology, hydrology, and geochemistry-A tribute volume to Derek C. Ford and William B. White*, Harmon, R.S., and Wicks, C., (Eds.), Geological Society of America Special Paper 404, 31–38.
- OZARK CAVE DIVING ALLIANCE (2005) Alley Spring, Shannon County, Missouri [cave map].
- TIKHONOV, A.N. (1950) The determination of the electrical properties of deep layers of the Earth's crust: *Doklady Akademii Nauk SSR*, **73**, 295–297.
- VOZOFF, K. (1986) *Magnetotelluric methods*. Tulsa, Oklahoma, Society of Exploration Geophysicists, Geophysics Reprint Series **5**, 763 pp.
- VOZOFF, K. (1991) The Magnetotelluric Method. Chap. 8, in *Electromagnetic methods in applied geophysics*: M.N. Nabighian, (Ed.), Society of Exploration Geophysicists, Tulsa, Oklahoma, Series, Investigations in Geophysics **3**, 641–712.
- WAIT, J.R. (1962) Theory of magnetotelluric fields: U.S. Department of Commerce, National Bureau of Standards, Journal of Research, Radio Propagation **66D**, 509–541.

ELECTRICAL RESISTIVITY IMAGING AND SYNTHETIC MODELING OF AN INFERRED COLLAPSE STRUCTURE—INNER SPACE CAVERNS, TEXAS, USA

BLAKE WEISSLING, PHD

SWCA Environmental Consultants

6200 UTSA Blvd. Ste. 102, San Antonio, TX 78249 USA, bweissling@swca.com

Abstract

Inner Space Caverns, discovered in the early 1960s during construction of an Interstate Highway (IH 35) in central Texas, USA, exists today as one of the largest caverns in the state from both a commercial perspective as well as surveyed extent. No known natural entrance exists for the cave system, yet paleo-entrances did exist as evidenced by Pleistocene mammal bones unearthed in various sections of the cave, particularly within or adjacent to in-cave debris/talus piles associated with paleo-collapse events of the cave ceiling.

Until recently, cave surveyors have characterized the spatial extent of these collapse features from sub-surface surveys alone – no obvious surface evidence exists today for these sinks or collapses due to extensive land modifications, primarily associated with the overlying highway system. One such feature, known as Bone Sink 2, was delineated on cave maps as a single large collapse structure encompassing approximately 3500 m², as evidenced from debris-blocked cave passage. New proposed road construction work over Bone Sink 2 and associated commercial trail cave passage has instigated a comprehensive geophysical investigation of the internal structure of this sink/collapse feature utilizing electrical resistivity imaging (ERI) techniques.

Approximately 1500 linear meters of ERI data were acquired over the Bone Sink 2 feature using an Advanced Geosciences, Inc. 8-Channel Earth Resistivity and Induced Polarization meter (Supersting R8 IP) in 2007 and 2008. A non-standard array was developed and employed for this survey combining the horizontal sensitivity and resolution of the dipole-dipole array with the vertical sensitivity of the inverse Schlumberger array. Where possible, survey lines were positioned over known cave passage for validation purposes. Inverted section profiles generated from the apparent resistivity pseudosections have indicated that the Bone Sink 2 feature is not a simple large sink collapse as conjectured, but rather includes a central region of intact cave passage surrounded by a ring-shaped collapse zone. The depth and dimension of the resistivity anomalies, interpreted as significant void space, is consistent with the depth and trend of the known passage immediately adjacent.

Forward synthetic modeling was conducted of several internal features of the Bone Sink for the purpose of anomaly confirmation as well as for identification of potential inversion artifacts. Strong adjacency effects (anomalies due to off-line features being projected onto the ERI profile) were observed in several ERI lines and were subsequently modeled. The morphology, trend, and pattern of the ERI anomalies are discussed in the context of present knowledge of this cave's genesis.

TOWARDS AN POSITIONING SYSTEM FOR THE SUBTERRANEAN WORLD (U-GPS)

REMY WENGER, PIERRE-YVES JEANNIN

Swiss Institute of Speleology and Karstology, SSKA, PO Box 818, CH-2301 La Chaux-de-Fonds, Switzerland (SSKA)

In order to determine accurately from the surface the position and depth of a subsurface point, the Swiss Institute of Speleology and Karstology (SSKA) has developed the Underground positioning system called U-GPS 1. It is a transmitter/receiver device which is able to detect the transmitter's position in the subsurface at depths ranging between 7 and 200 m. Elaborate and expensive topographic measures become redundant while using the U-GPS 1 to localize old mining galleries and other cavities in urban or natural landscape.

Various applications and tests have been carried out in natural and artificial cavities. Results from measurement campaigns in Switzerland, France, Greece and Brazil make it possible to determine the strengths and weaknesses of this system, which turned out to be very efficient in most applications. They also helped to better define the limits of the system's practical applications and to discover various tricks that make it easier to use. The direction of further development is currently being discussed.

In 2007, the SSKA, the INERIS (Institut National de l'Environnement industriel et des RISques) and other partners started to develop a more powerful device called U-GPS 2. The positioning of a moving transmitter is now possible in real time. This brings the U-GPS 2 system close to the conventional surface GPS. A prototype is available since March 2009 and results of the first tests will be presented at the congress, but came too late to be presented in this paper. This new system could represent a real revolution in cave survey techniques in a close future!

1. Introduction

GPS became a very common instrument in very many human activities. However this system does not work well (or at all) in a "closed" environment such as caves and underground chambers or passages. Nevertheless, a GPS working in the underground would be very useful to survey caves and old mines or to locate instruments or observations made in caves. U-GPS 1 is a first development in this direction. This type of tool was already developed in the sixties (Mixon 1966, Glover 1976) and was improved up to beginning of the 21st Century (France 2001, Gibson 2001, Gibson 2005). The principle of this method is to place a transmitter in the cave and to locate it with a receiver at the surface. U-GPS 2 is a second step forward, because it should be more precise and much quicker, allowing for a continuous measurement of the position of someone walking in a cave.

2. Presentation of the Instrument (U-GPS 1)

Already in the seventies a series electromagnetic prototypes for the positioning of a transmitter in cave have been developed (at least in Britain, France and Switzerland). The minimal requirements for the development of those instruments were to be able to reach at least a distance of

100 m with a precision typically in the order of 1%.

With U-GPS 1 the measurement can be made vertically (determination of the position of the transmitter in X, Y coordinates) or oblique. The precision and the reliability of the positioning can be improved by making several measurements of the same point with different orientations of the antennas. The instrument indicates the distance with a 10 cm resolution, what provides also a good control on the data.

The maximum detection distance is determined mainly by the size of the transmitter antenna. With 1 m² a maximum of 200 m is reached. The transmitter radiates an electromagnetic field with a frequency of 3075 Hz. The signal intensity of the transmitter is well known and stable. As the intensity of the signal decreases with the cube of the distance, the measurement of the distance is possible by measuring the signal amplitude detected by the receiver. A usual problem with this method is the accuracy which depends on how much the signal attenuates in a given geologic setting. The composition of earth materials around the cave should ideally be known, what makes it a calibration quite difficult.

Although the use is principally simple some training is needed in order to make correct measurements. A calibration of the receiver is required. Results are very sensitive to the calibration. Once the receiver has been calibrated the user has to move the receiver in the area which is expected to be close to the transmitter. There should not be much electromagnetic noise in the survey area otherwise the measurement may be difficult or even impossible.

In its present form (produced piece by piece, Figure 1) the transmitter is 5 kg weight and the receiver 2.3 kg. The antenna is made up by 8 aluminum sticks of 50 cm each, which have to be assembled in a 1 m square. The antenna may be installed horizontally, vertically or even oblique. However the best and standard position is horizontal.



Figure 1: View of the U-GPS 1 instrument.

The device is able to measure between 7 and 200 meters. Tests carried out at land-surface showed that the precision strongly decreases beyond 100 m and is bad beyond 150 m. In these conditions the indication provided by the instrument underestimates the real values (Fig. 2).

The precision of the positioning in plan is not so strongly influenced by the distance and a reasonable precision of about 2-3 m can be obtained at 150 to 200 m depth. In any case the presence of powerlines and of

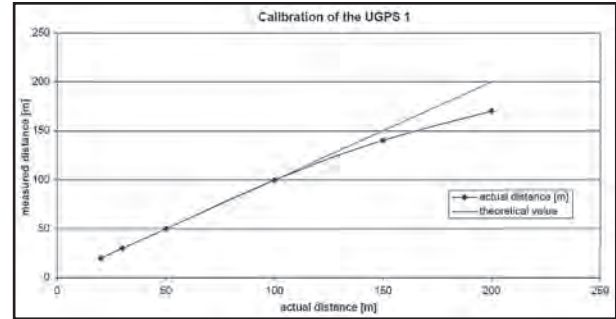

Figure 2: Calibration of the distance indicated by the instrument.

very large metal masses (e.g. railways, bulldozers) is a more crucial problem, which can make measurements completely impossible. If signals can still be received it is advised to make several measurements of the same points in various settings of the system in order to provide control measurements.

3. Case Studies

Most often U-GPS 1 is used when, for any reason, a borehole has to be drilled down to hit a known conduit (e.g. for tapping water, for rescue issues, etc.). It can also be used in order to verify or even introduce corrections in a cave survey.

3.1 Measurements in Désert de Platé, Haute-Savoie, France

The Poya cave is a typical alpine cave going down to 376 m. From the cave bottom a series of passages have been explored upwards and surveyed. The cavers were interested in fixing the precision of their survey in this part of the cave. Measurements have been carried out in winter with about 1 m snow. The signal was very well received despite the presence of a ski-lift very close. The measured distance was 110 m. Various tests have been made to control the first measurement and the value and position could be well reproduced within an area of about 3 x 3 m. Conditions in the cave were not very good (water and mud) but the transmitter did work correctly. This showed that the instrument is adequate for real cave conditions.

3.2 Measurements in Grande Rolaz Cave (Jura Mountains, Switzerland)

This site was especially well surveyed (with a theodolite) in a previous scientific work, meaning that we had a good way to verify the positioning capacity of the instrument.

Five measurements have been made (Fig. 3). They show a systematic shift by about 2-3 meters, what is very surprising considering that the depth never exceed 20 meters. However

Test de l'UGPS-ISSKA sur le site de la Grande-Rolaz, 21.10.05
 en rouge, localisation de l'antenne émettrice au moyen de l'instrument
 en noir, stations topographiques

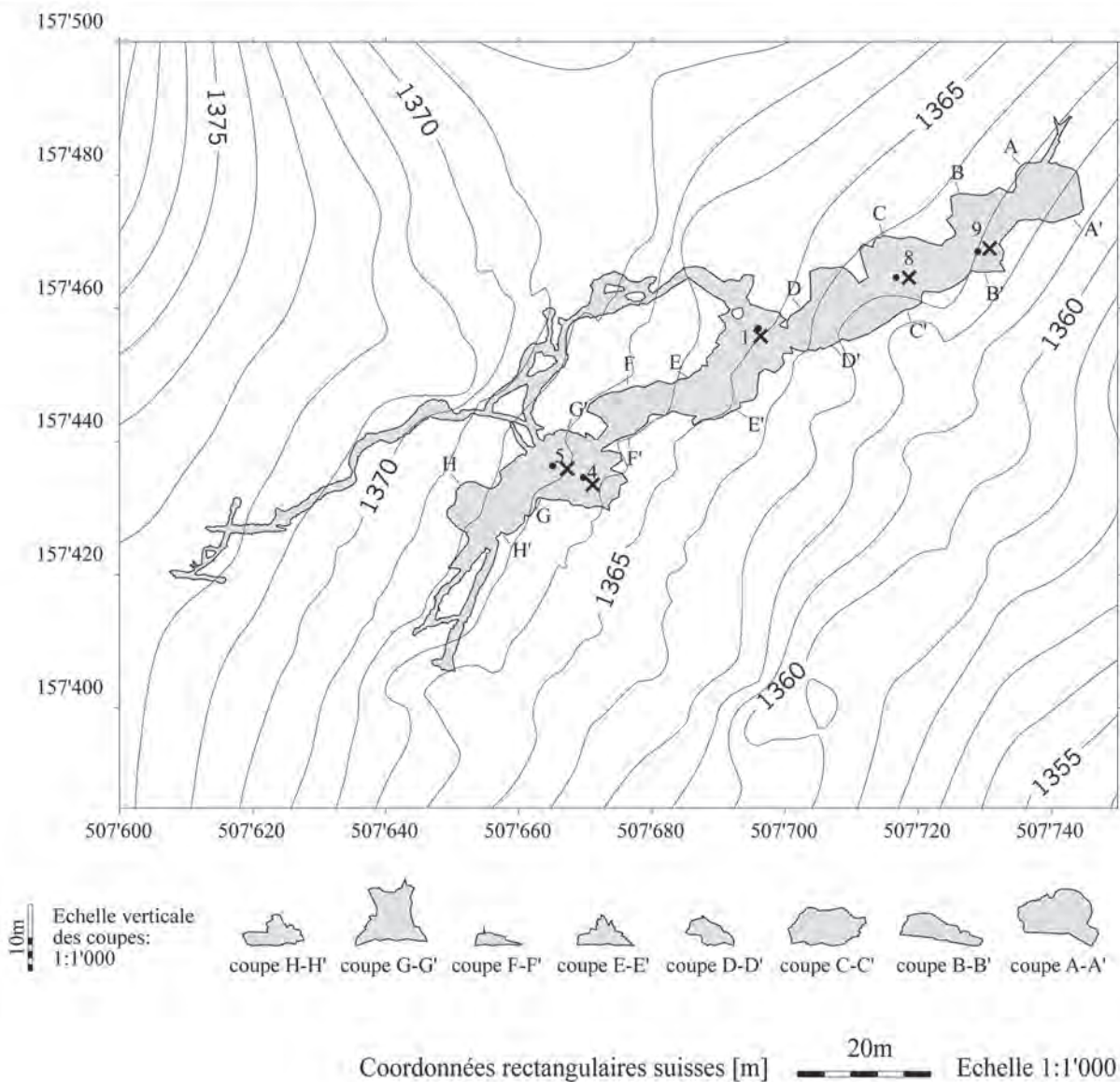

Figure 3: Measurements undertaken with U-GPS 1 at the Grande-Rolaz cave. The shift observed between the control points and the position estimated by U-GPS 1 let us expect that U-GPS 1 is more precise than the cave survey (systematic error of about 2 to 3 meters).

it came out that the shift is almost exactly the same for all points. We thus expect that the “well documented survey” had a systematic error. It could also be possible that some geological feature produce this shift, but it is more unlikely. Electromagnetic perturbations can be excluded in the present case.

3.3 Measurements in the Grotte aux Fées (Jura Mountains, Switzerland)

This cave was explored along the last 5 years over a distance of more than 12 km. The main passage is more than 4 km away from the single cave entrance. It encloses some nasty passage (tide, muddy and wet), which does not contribute

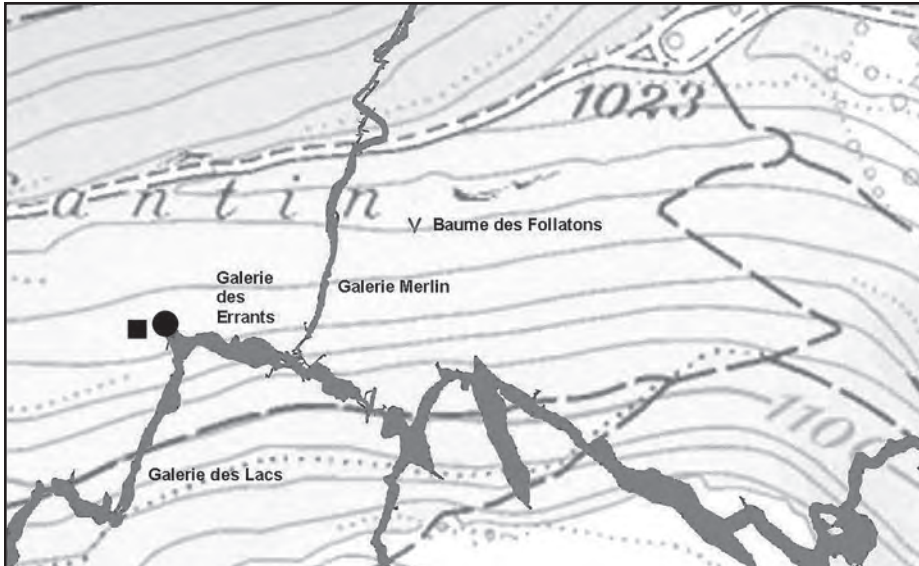

Figure 4: Measurements undertaken in the Grotte aux Fées. The cave survey could be controlled. The indicated depth seems very reasonable (107 m instead of 105 m expected).

to improve the precision of the survey. At such a distance cavers did not trust their survey very much. Because they were interested in finding a new entrance directly in the remote part of the cave, they would like to be sure to look for a new entrance in the right area. Thus, they asked for a control measurement with U-GPS 1 (Fig. 4).

The measurement was made about 3 km away from the cave entrance and it evidenced a horizontal error of only 25 m. Vertically, the survey gave a depth of 105 m and the measurement gave 107 m! Their survey was not bad at all...Once they have been sure to be at the right place they started to “push” the exploration of a shaft in the neighborhood. After a few months the connection could be

established. The cave has now a second entrance.

but not least: there is no water at all in the whole cave system! To continue the exploration the Brazilian cavers think about drilling a borehole in order to be able to bring water directly in the far end of the cave system.

The cave was surveyed but the cavers would like to control the survey before drilling the hole. Ten measurements were made in order to fix the survey. Among them two measurements were place at the potential locations for a drillhole. Such a series of ten measurements would not have been possible without the use of a wireless cave phone (Nicola System), which functions very well.

For these measurements we first tested the reliability of

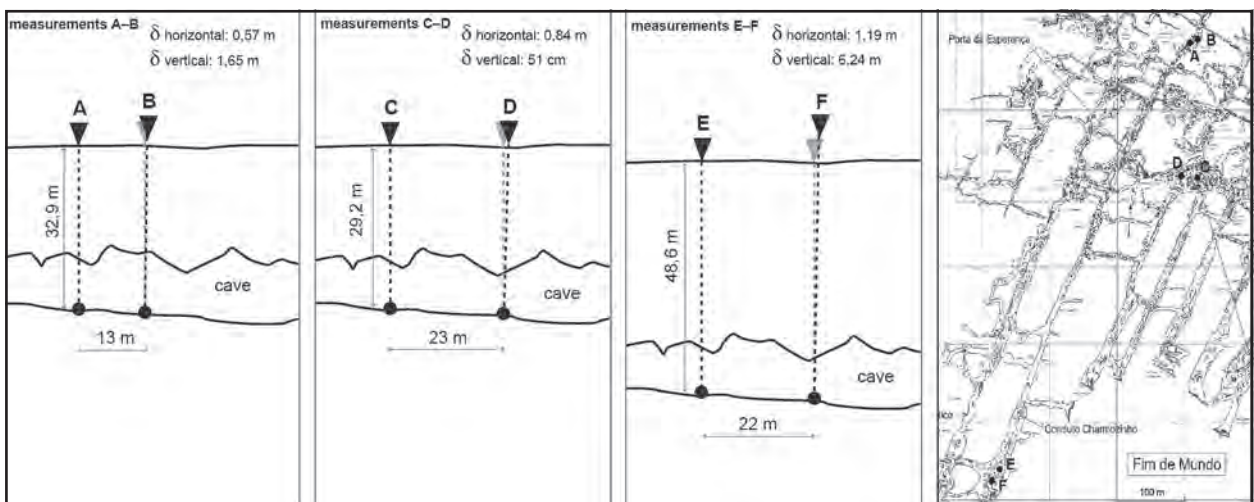

Figure 5: Measurements undertaken in the Boa Vista Cave (Brazil). Errors ranging between 0.44 and 1.58 m have been noticed at depth between 30 and 70 m.

the instrumentation in the Brazilian context. Therefore we measured one first station, and afterwards two further stations 15 and 30 meters away from the first one respectively. The relative position of the stations has been surveyed underground and at land-surface. With this method shifts ranging between 0.44 and 1.58 m could be identified (Fig. 5).

For all ten measurement stations the signal quality was very good. Once the maximum signal was found a displacement of one or two meters was clearly identified on the distance given by the instrument. The depth range of the measurements was included between 29.2 and 67.9 m. The geological setting (pure and dry limestone without any significant soil cover) together with a very low electromagnetic smog were probably the main reason for a very good signal.

The estimated errors on distance readings range between 21 cm and 6.24 meters. This last "bad" measurement was mainly related to bad conditions for the receiver: The point was located inside a thick bush of small trees. However, it could also be related to a bad calibration of the receiver for this particular measurement.

By the time we write this note we do not know if the borehole has been drilled, what would provide an interesting control on our measurements. If it turns out to be correct the application of the U-GPS1 would have been by far the best method to fix the cave survey, because a theodolite survey would have represented a huge work!

4. Measurements in Urban Environment

Our colleagues from INERIS (French Institute on natural and industrial risk management) applied U-GPS 1 to fix old plans of artificial mines, especially in urban regions where security issues are related to underground voids.

The most common situation is that old plans of the mines do exist with a reasonable precision, but their orientation is not known! With a few measurements the orientation of the plans can be determined and their precision controlled. In some cases, plans are not complete and the non-surveyed extension of the mines can be measured with a few measurements. In other cases, problematic areas in the underground passage can be identified. Their position at land-surface can be directly determined with the U-GPS in order to assess the potential shades. The reading of the distance to the surface is also an important indication.

The U-GPS is thus commonly applied in an urban

environment and provides acceptable results. However one should not expect to be able to make measurements much deeper than 30 to 50 meters. This is however sufficient in most urban situation.

5. Underground-GPS 2

With the underground-GPS 2 positioning system, it is now possible to follow in real time and in 3 dimensions a transmitter moving around in a cavity under the surface! The first prototype is functional since March 2009 (Fig. 6).

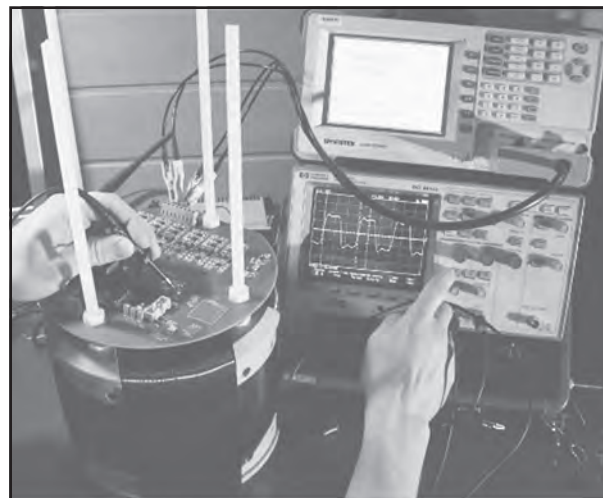

Figure 5: Measurements undertaken in the Boa Vista Cave (Brazil). Errors ranging between 0.44 and 1.58 m have been noticed at depth between 30 and 70 m.

The precision is in the range of 1% and U-GPS 2 allows its user to take measurements up to a distance of 200 m. With this system, it is possible to move through a cave or a mine with a bag on the back and to record the position every 5 seconds. This technique should progressively avoid the classical measurements with a theodolite or a compass/clinometer.

Applications of this system will be presented at the congress, but only the very first tests have been conducted by the time we write this paper.

6. Conclusion

U-GPS 1 proved to be able to locate the position X-Y position of a transmitter with a precision of a few decimetres for a depth between 5 and 50 meters. Positioning is less precise at greater depth and possible in good conditions down to 200 m. The exact precision will be known once boreholes will have been drilled on positions determined by this system. The system works pretty well, even in an urban environment. The system is adequate for being transported in most cave and mines conditions. However this system

could be improved. For instance the precision is directly related to the exact horizontal setting of the transmitter antenna. The distance measurement is not very reliable. Obviously some geological parameters (e.g. shale layers) have an influence on the measured distance. Another problem is that contacts of the transmitter antenna are sometimes difficult to be guaranteed. Eight aluminium sticks have to be screwed together and obviously the contact is not always good enough.

U-GPS 2 is a much better instrument with a precision in the order of 1% down to a depth of about 200 meters. By the time we write this paper we are doing the very first tests with this new device. If results are good enough we will probably not improve U-GPS 1 further and switch to U-GPS 2. Results on U-GPS 2 will be presented at the congress.

References

- France, S. 2001. Cave Surveying by Radio-Location - 2, Cave Radio & Electronics Group Journal, 44: 21–23.
- Gibson, D. 2001a. Cave Surveying by Radio-Location - 1. Cave Radio & Electronics Group Journal, 43: 24–26.
- Gibson D. 2005. Cave radiolocation. – Gibson publisher: 70 pp.
- Glover, R.R. 1976. Cave surveying by electromagnetic induction. In *Surveying Caves*, edited by B. Ellis, Bridgwater: British Cave Research Association.
- Mixon, W. 1966, Locating an underground transmitter by surface measurements. *National Speleological Society News*. 24(4): 61,74–75.

Kerrville, Texas USA
July 19-26, 2009



GREYHOUND PRESS